

Vostro 3690

Service Manual



Notes, cautions, and warnings

 **NOTE:** A NOTE indicates important information that helps you make better use of your product.









 **CAUTION:** A CAUTION indicates either potential damage to hardware or loss of data and tells you how to avoid the problem.

 **WARNING:** A WARNING indicates a potential for property damage, personal injury, or death.

Working inside your computer

Safety instructions

Use the following safety guidelines to protect your computer from potential damage and to ensure your personal safety. Unless otherwise noted, each procedure included in this document assumes that you have read the safety information that shipped with your computer.



-  **WARNING:** Before working inside your computer, read the safety information that is shipped with your computer. For more safety best practices, see the Regulatory Compliance home page at www.dell.com/regulatory_compliance.
-  **WARNING:** Disconnect your computer from all power sources before opening the computer cover or panels. After you finish working inside the computer, replace all covers, panels, and screws before connecting your computer to an electrical outlet.
-  **CAUTION:** To avoid damaging the computer, ensure that the work surface is flat, dry, and clean.
-  **CAUTION:** To avoid damaging the components and cards, handle them by their edges, and avoid touching the pins and the contacts.
-  **CAUTION:** You should only perform troubleshooting and repairs as authorized or directed by the Dell technical assistance team. Damage due to servicing that is not authorized by Dell is not covered by your warranty. See the safety instructions that is shipped with the product or at www.dell.com/regulatory_compliance.
-  **CAUTION:** Before touching anything inside your computer, ground yourself by touching an unpainted metal surface, such as the metal at the back of the computer. While you work, periodically touch an unpainted metal surface to dissipate static electricity which could harm internal components.
-  **CAUTION:** When you disconnect a cable, pull it by its connector or its pull tab, not the cable itself. Some cables have connectors with locking tabs or thumbscrews that you must disengage before disconnecting the cable. When disconnecting cables, keep them evenly aligned to avoid bending the connector pins. When connecting cables, ensure that the ports and the connectors are correctly oriented and aligned.
-  **CAUTION:** Press and eject any installed card from the media-card reader.
-  **NOTE:** The color of your computer and certain components may appear differently than shown in this document.

Before working inside your computer

About this task

-  **NOTE:** The images in this document may differ from your computer depending on the configuration you ordered.

Steps

1. Save and close all open files and exit all open applications.
2. Shut down your computer. Click **Start** >  **Power** > **Shut down**.
 -  **NOTE:** If you are using a different operating system, see the documentation of your operating system for shut-down instructions.

3. Disconnect your computer and all attached devices from their electrical outlets.
4. Disconnect all attached network devices and peripherals, such as keyboard, mouse, and monitor from your computer.

 **CAUTION: To disconnect a network cable, first unplug the cable from your computer and then unplug the cable from the network device.**

5. Remove any media card and optical disc from your computer, if applicable.

Safety precautions

The safety precautions chapter details the primary steps to be taken before performing any disassembly instructions.

Observe the following safety precautions before you perform any installation or break/fix procedures involving disassembly or reassembly:

- Turn off the system and all attached peripherals.
- Disconnect the system and all attached peripherals from AC power.
- Disconnect all network cables, telephone, and telecommunications lines from the system.
- Use an ESD field service kit when working inside any tablet/notebook/desktop to avoid electrostatic discharge (ESD) damage.
- After removing any system component, carefully place the removed component on an anti-static mat.
- Wear shoes with non-conductive rubber soles to reduce the chance of getting electrocuted.

Standby power

Dell products with standby power must be unplugged before you open the case. Systems that incorporate standby power are essentially powered while turned off. The internal power enables the system to be remotely turned on (wake on LAN) and suspended into a sleep mode and has other advanced power management features.

Unplugging, pressing and holding the power button for 15 seconds should discharge residual power in the system board. Remove the battery from tablets/notebooks.

Bonding

Bonding is a method for connecting two or more grounding conductors to the same electrical potential. This is done through the use of a field service electrostatic discharge (ESD) kit. When connecting a bonding wire, ensure that it is connected to bare metal and never to a painted or non-metal surface. The wrist strap should be secure and in full contact with your skin, and ensure that you remove all jewelry such as watches, bracelets, or rings prior to bonding yourself and the equipment.

Electrostatic discharge—ESD protection

ESD is a major concern when you handle electronic components, especially sensitive components such as expansion cards, processors, memory DIMMs, and system boards. Very slight charges can damage circuits in ways that may not be obvious, such as intermittent problems or a shortened product life span. As the industry pushes for lower power requirements and increased density, ESD protection is an increasing concern.

Due to the increased density of semiconductors used in recent Dell products, the sensitivity to static damage is now higher than in previous Dell products. For this reason, some previously approved methods of handling parts are no longer applicable.

Two recognized types of ESD damage are catastrophic and intermittent failures.

- **Catastrophic** – Catastrophic failures represent approximately 20 percent of ESD-related failures. The damage causes an immediate and complete loss of device functionality. An example of catastrophic failure is a memory DIMM that has received a static shock and immediately generates a "No POST/No Video" symptom with a beep code emitted for missing or nonfunctional memory.
- **Intermittent** – Intermittent failures represent approximately 80 percent of ESD-related failures. The high rate of intermittent failures means that most of the time when damage occurs, it is not immediately recognizable. The DIMM receives a static shock, but the tracing is merely weakened and does not immediately produce outward symptoms related to the damage. The weakened trace may take weeks or months to melt, and in the meantime may cause degradation of memory integrity, intermittent memory errors, etc.

The more difficult type of damage to recognize and troubleshoot is the intermittent (also called latent or "walking wounded") failure.

Perform the following steps to prevent ESD damage:

- Use a wired ESD wrist strap that is properly grounded. The use of wireless anti-static straps is no longer allowed; they do not provide adequate protection. Touching the chassis before handling parts does not ensure adequate ESD protection on parts with increased sensitivity to ESD damage.
- Handle all static-sensitive components in a static-safe area. If possible, use anti-static floor pads and workbench pads.
- When unpacking a static-sensitive component from its shipping carton, do not remove the component from the anti-static packing material until you are ready to install the component. Before unwrapping the anti-static packaging, ensure that you discharge static electricity from your body.
- Before transporting a static-sensitive component, place it in an anti-static container or packaging.

ESD field service kit

The unmonitored Field Service kit is the most commonly used service kit. Each Field Service kit includes three main components: anti-static mat, wrist strap, and bonding wire.

Components of an ESD field service kit

The components of an ESD field service kit are:

- **Anti-Static Mat** – The anti-static mat is dissipative and parts can be placed on it during service procedures. When using an anti-static mat, your wrist strap should be snug and the bonding wire should be connected to the mat and to any bare metal on the system being worked on. Once deployed properly, service parts can be removed from the ESD bag and placed directly on the mat. ESD-sensitive items are safe in your hand, on the ESD mat, in the system, or inside a bag.
- **Wrist Strap and Bonding Wire** – The wrist strap and bonding wire can be either directly connected between your wrist and bare metal on the hardware if the ESD mat is not required, or connected to the anti-static mat to protect hardware that is temporarily placed on the mat. The physical connection of the wrist strap and bonding wire between your skin, the ESD mat, and the hardware is known as bonding. Use only Field Service kits with a wrist strap, mat, and bonding wire. Never use wireless wrist straps. Always be aware that the internal wires of a wrist strap are prone to damage from normal wear and tear, and must be checked regularly with a wrist strap tester in order to avoid accidental ESD hardware damage. It is recommended to test the wrist strap and bonding wire at least once per week.
- **ESD Wrist Strap Tester** – The wires inside of an ESD strap are prone to damage over time. When using an unmonitored kit, it is a best practice to regularly test the strap prior to each service call, and at a minimum, test once per week. A wrist strap tester is the best method for doing this test. If you do not have your own wrist strap tester, check with your regional office to find out if they have one. To perform the test, plug the wrist-strap's bonding-wire into the tester while it is strapped to your wrist and push the button to test. A green LED is lit if the test is successful; a red LED is lit and an alarm sounds if the test fails.
- **Insulator Elements** – It is critical to keep ESD sensitive devices, such as plastic heat sink casings, away from internal parts that are insulators and often highly charged.
- **Working Environment** – Before deploying the ESD Field Service kit, assess the situation at the customer location. For example, deploying the kit for a server environment is different than for a desktop or portable environment. Servers are typically installed in a rack within a data center; desktops or portables are typically placed on office desks or cubicles. Always look for a large open flat work area that is free of clutter and large enough to deploy the ESD kit with additional space to accommodate the type of system that is being repaired. The workspace should also be free of insulators that can cause an ESD event. On the work area, insulators such as Styrofoam and other plastics should always be moved at least 12 inches or 30 centimeters away from sensitive parts before physically handling any hardware components
- **ESD Packaging** – All ESD-sensitive devices must be shipped and received in static-safe packaging. Metal, static-shielded bags are preferred. However, you should always return the damaged part using the same ESD bag and packaging that the new part arrived in. The ESD bag should be folded over and taped shut and all the same foam packing material should be used in the original box that the new part arrived in. ESD-sensitive devices should be removed from packaging only at an ESD-protected work surface, and parts should never be placed on top of the ESD bag because only the inside of the bag is shielded. Always place parts in your hand, on the ESD mat, in the system, or inside an anti-static bag.
- **Transporting Sensitive Components** – When transporting ESD sensitive components such as replacement parts or parts to be returned to Dell, it is critical to place these parts in anti-static bags for safe transport.

ESD protection summary

It is recommended that all field service technicians use the traditional wired ESD grounding wrist strap and protective anti-static mat at all times when servicing Dell products. In addition, it is critical that technicians keep sensitive parts separate from all insulator parts while performing service and that they use anti-static bags for transporting sensitive components.

After working inside your computer

About this task

 **CAUTION:** Leaving stray or loose screws inside your computer may severely damage your computer.

Steps

1. Replace all screws and ensure that no stray screws remain inside your computer.
2. Connect any external devices, peripherals, or cables you removed before working on your computer.
3. Replace any media cards, discs, or any other parts that you removed before working on your computer.
4. Connect your computer and all attached devices to their electrical outlets.
5. Turn on your computer.

Disassembly and reassembly

Recommended tools

The procedures in this document require the following tools:

- Phillips # 1 screwdriver
- Small flat blade screwdriver



Screw List

The following table shows the screw list and the images for different components.

- ① **NOTE:** When removing screws from a component, it is recommended to note the screw type, the quantity of screws, and then place them in a screw storage box. This is to ensure that the correct number of screws and correct screw type is restored when the component is replaced.
- ① **NOTE:** Some computers have magnetic surfaces. Ensure that the screws are not left attached to such surface when replacing a component.
- ① **NOTE:** Screw color may vary with the configuration ordered.

Table 1. Screw list









| Component | Screw type | Quantity | Image |
|---------------------------------|----------------|----------|---|
| Side cover | #6-32 | 2 |  |
| M.2 2230/2280 Solid-state drive | M2x3.5 | 1 |  |
| Wireless card | M2x3 | 1 |  |
| Power-supply unit | #6-32 | 3 |  |
| Fan and heat-sink assembly | Captive screws | 4 |  |

Table 1. Screw list

| Component | Screw type | Quantity | Image |
|---------------------|-------------------|-----------------|---|
| 2.5-inch hard drive | M3x3 | 4 |  |
| 3.5-inch hard drive | #6-32 | 4 |  |
| Hard-drive bracket | #6-32 | 1 |  |
| System board | #6-32 | 7 |  |

Major components of your system

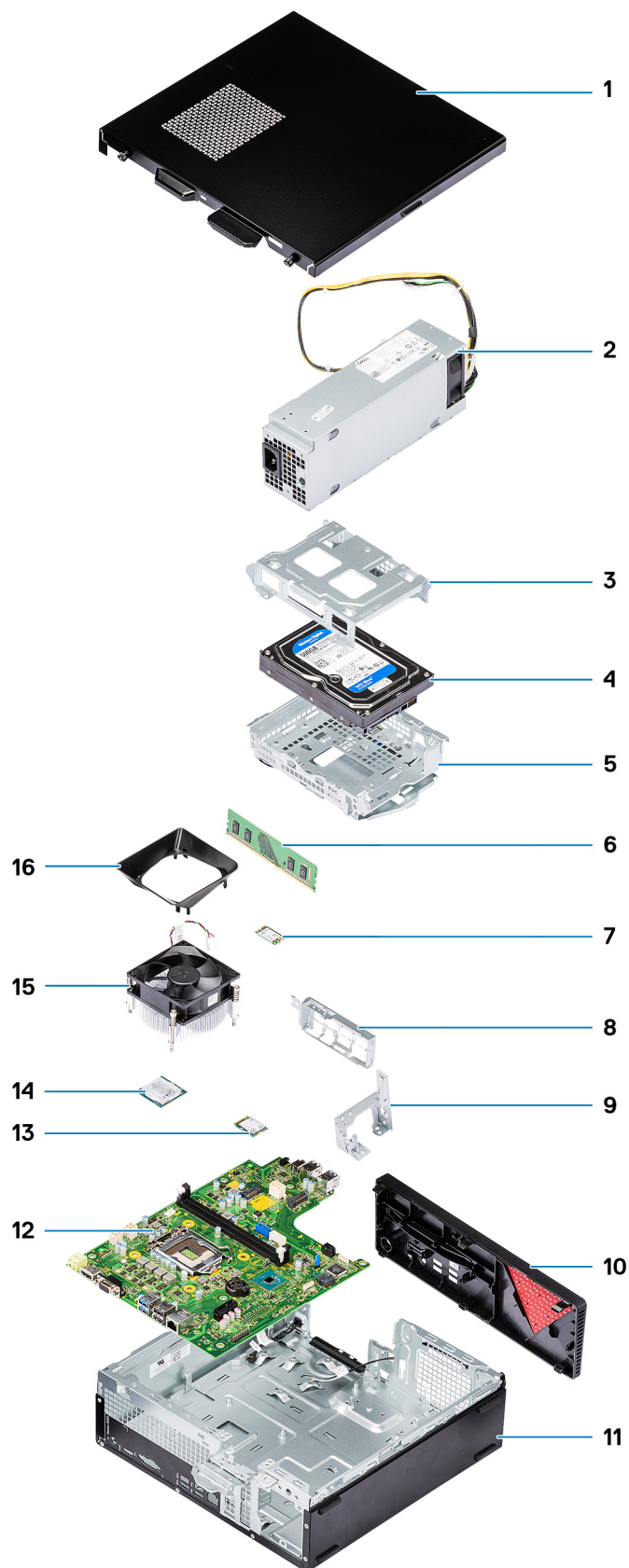

1. Side cover

2. Power-supply unit
3. Hard-drive assembly
4. Hard-drive assembly
5. Hard-drive bracket
6. Memory module
7. WLAN card
8. Front I/O bracket
9. Hard-drive bay support bracket
10. Front bezel
11. Chassis
12. System board
13. Graphics card
14. Processor
15. Fan and Heat-sink assembly
16. Fan shroud

Side cover

Removing the side cover

Prerequisites

1. Follow the procedure in [Before working on your computer](#).

 **NOTE:** Ensure that the security cable is removed from the security-cable slot (if applicable).

About this task

The following images indicate the location of the side cover and provide a visual representation of the removal procedure:

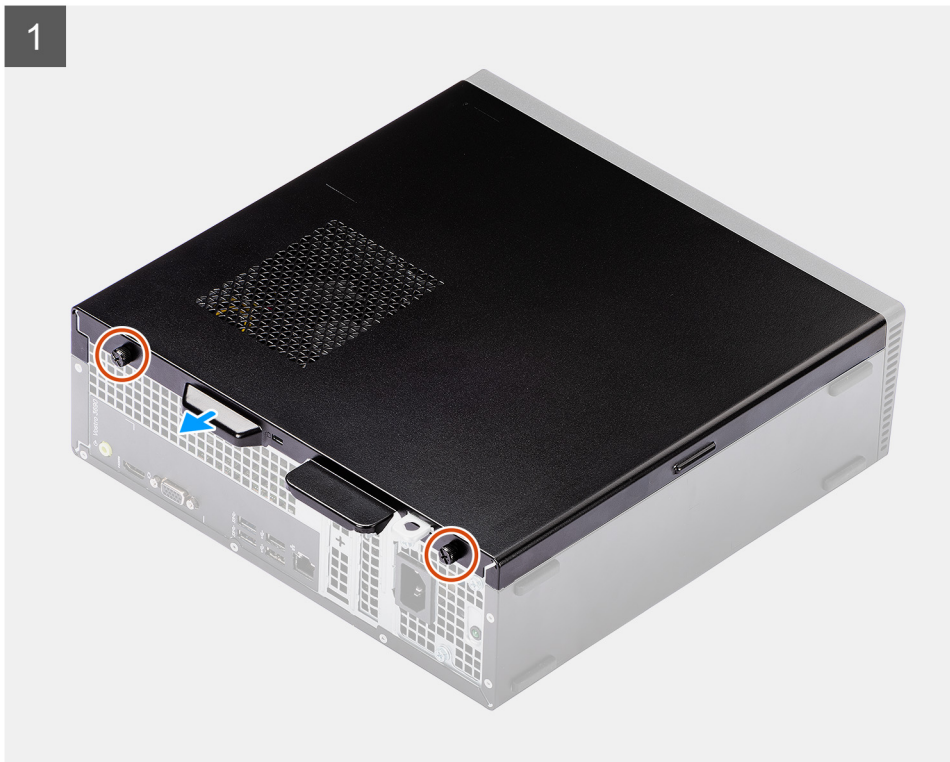

2

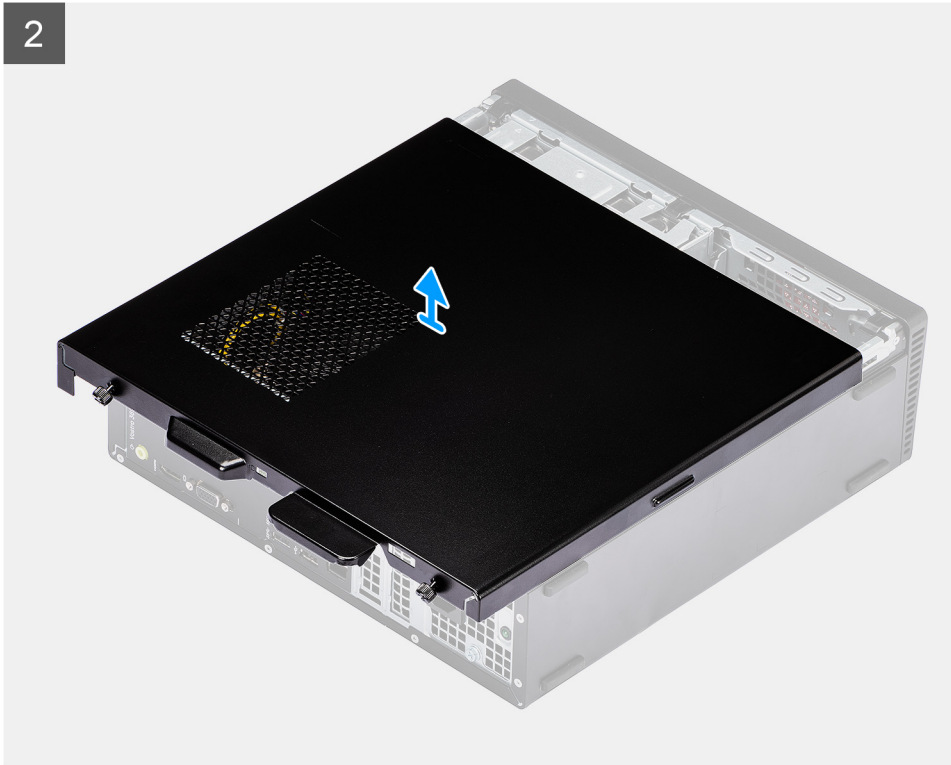

Steps

1. Loosen the two thumbscrews (#6-32) that secure the side cover to the chassis.
2. Slide and lift the side cover from the chassis.

Installing the side cover

Prerequisites

If you are replacing a component, remove the existing component before performing the installation procedure:

About this task

The following images indicate the location of the side cover and provide a visual representation of the installation procedure.

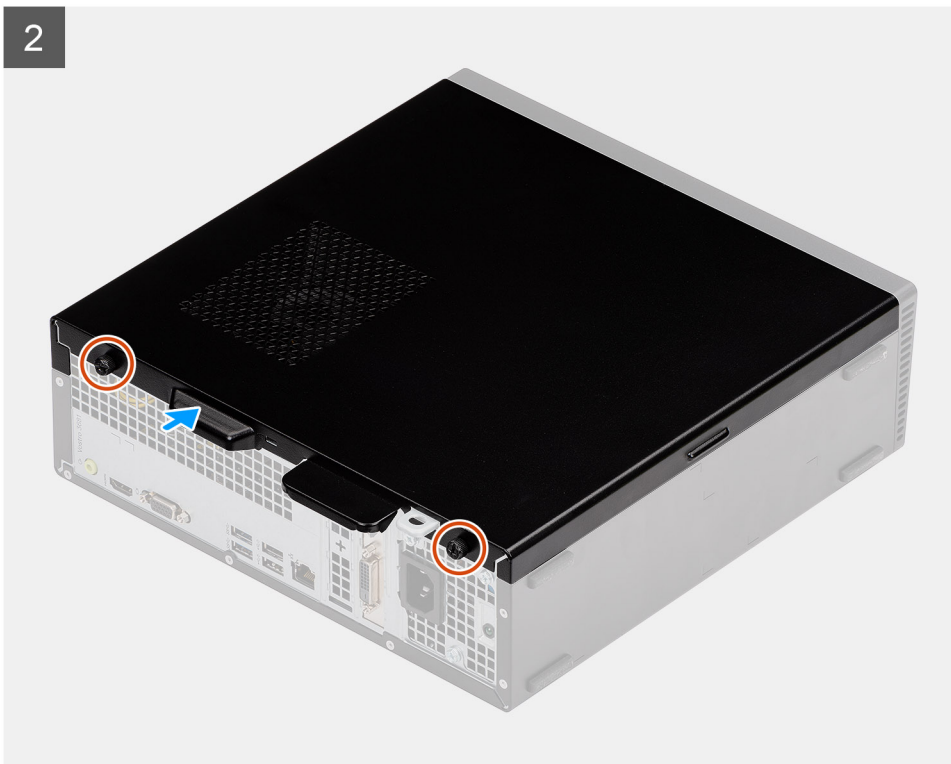
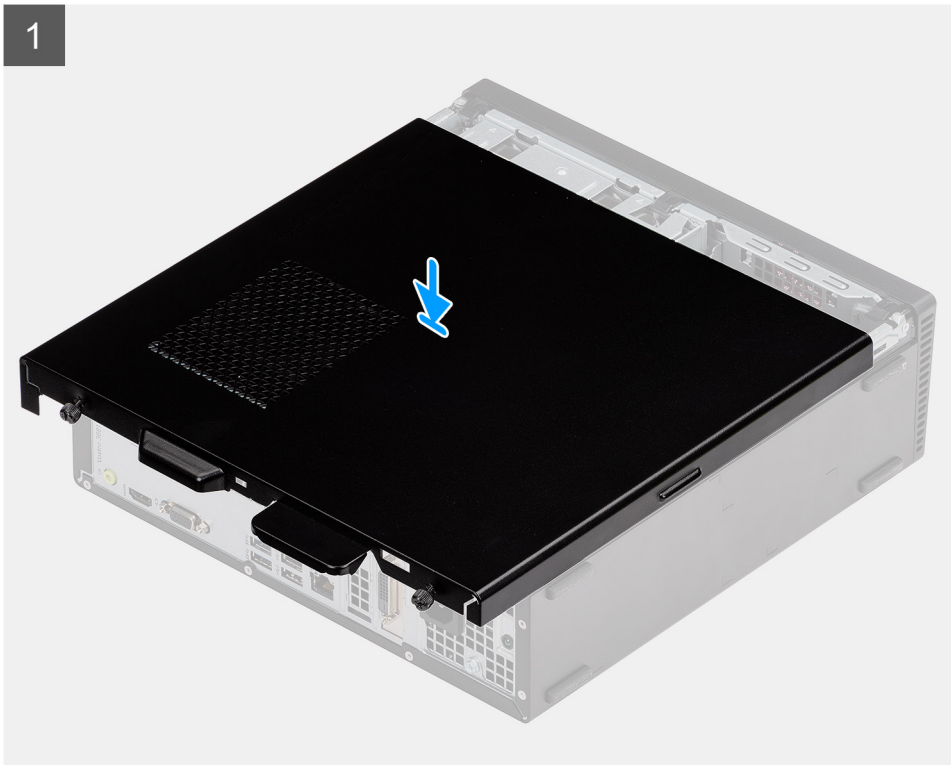

Steps

1. Align the tabs on the side cover with the slots on the chassis.
2. Slide the side cover towards the front of the computer until it snaps in place.
3. Tighten the two thumbscrews (#6-32) to secure the side cover to the chassis.

Next steps

1. Follow the procedure in [After working inside your computer](#).

Front cover

Removing the front cover

Prerequisites

1. Follow the procedure in [before working inside your computer](#).
2. Remove the [side cover](#).

About this task

The following images indicate the location of the front cover and provide a visual representation of the removal procedure:

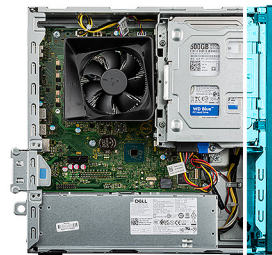

Steps

1. Gently pry and release the front-cover tabs sequentially from the top.
2. Rotate the front cover outward from the chassis.
3. Remove the front cover from the computer.

Installing the front cover

Prerequisites

If you are replacing a component, remove the existing component before performing the installation procedure.

About this task

The following image indicates the location of the front cover and provides a visual representation of the installation procedure:

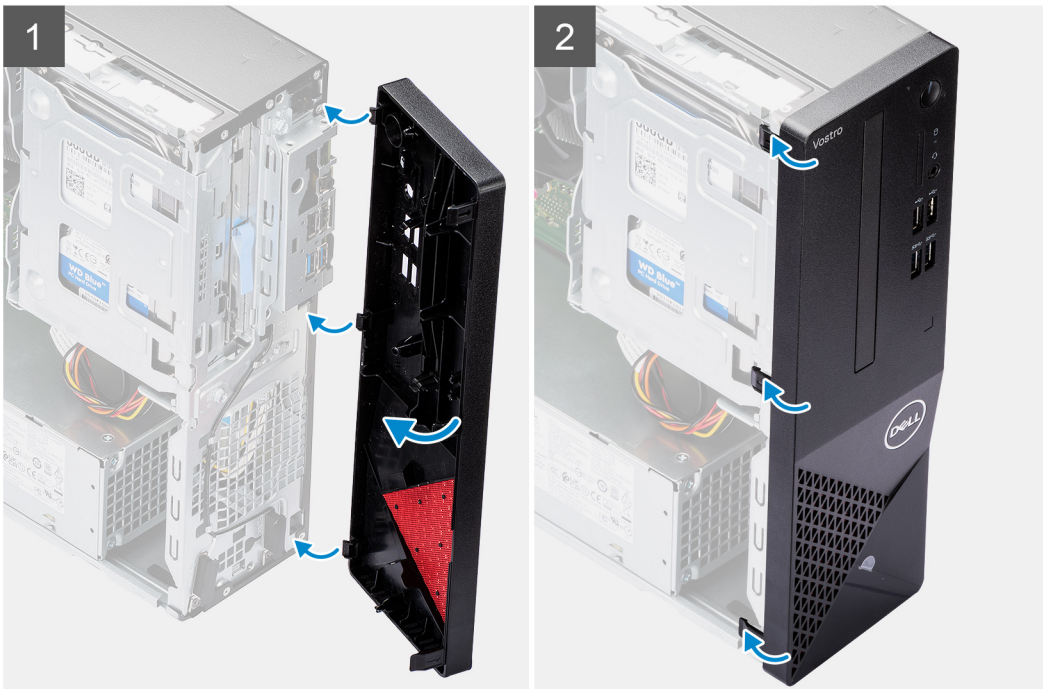
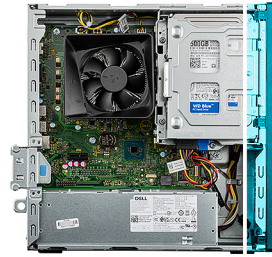

Steps

1. Position the front cover to align the tab holders on the cover with the slots on the chassis.
2. Press the front cover until the tabs clicks into place and tighten the three hooks in place.

Next steps

1. Install the [side cover](#).
2. Follow the procedure in [after working inside your computer](#).

Memory modules

Removing the memory modules

Prerequisites

1. Follow the procedure in [before working inside your computer](#).
2. Remove the [side cover](#).
3. Remove the [front cover](#).
4. Remove the [2.5-inch hard drive](#) or [3.5-inch hard drive](#), whichever applicable.
5. Remove the [hard-drive bracket](#).

About this task

CAUTION: To prevent damage to the memory module, hold the memory module by the edges. Do not touch the components on the memory module.

NOTE: Note the slot and the orientation of the memory module in order to install the replacement in the correct slot.

The following image indicates the location of the memory modules and provides a visual representation of the removal procedure:

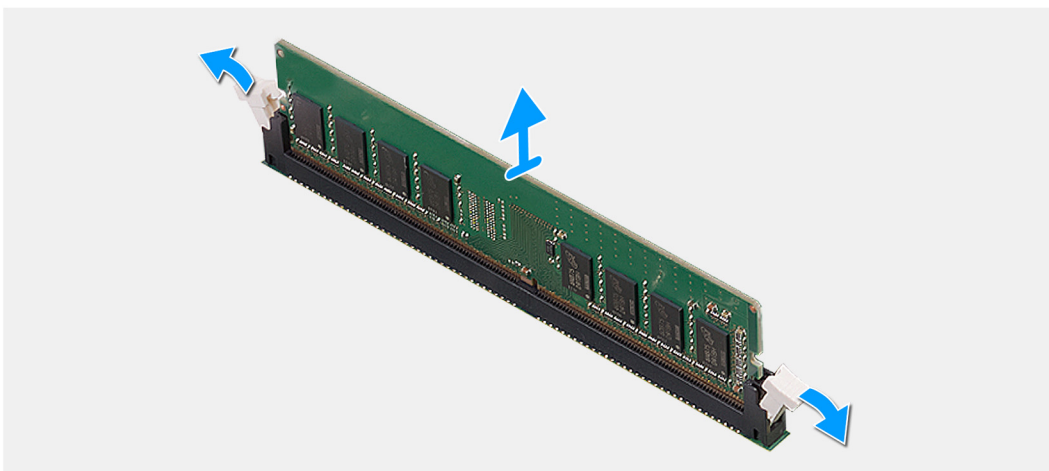
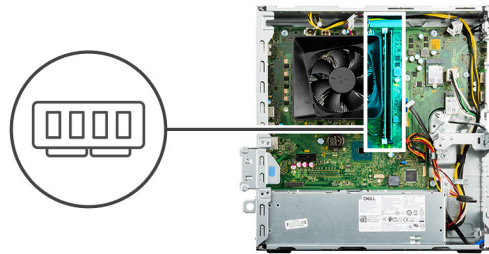

Steps

1. Use your fingertips to carefully spread apart the securing-clips on each end of the memory-module slot.
2. Grasp the memory module near the securing clip, and then gently ease the memory module out of the memory-module slot.

NOTE: Repeat step 1 to step 2 to remove any other memory module installed in your computer.

NOTE: If the memory module is difficult to remove, gently ease the memory module back and forth to remove it from the slot.

Installing the memory modules

Prerequisites

If you are replacing a component, remove the existing component before performing the installation procedure.

About this task

NOTE: Caution: To prevent damage to the memory module, hold the memory module by the edges. Do not touch the components on the memory module.

The following image indicates the location of the memory modules and provides a visual representation of the installation procedure.

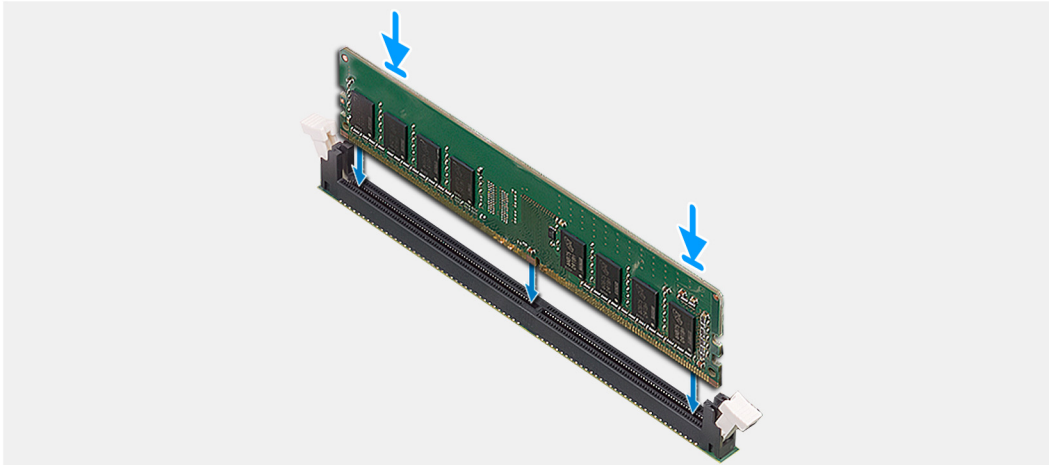
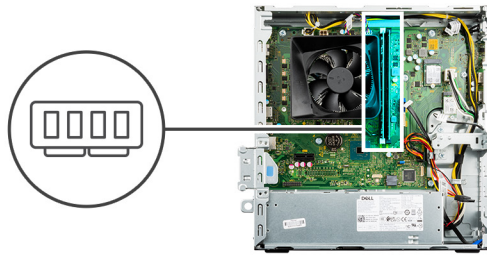

Steps

1. Ensure that the securing-clips are in the open position.
2. Align the notch on the memory module with the tab on the memory-module slot.
3. Insert the memory module into the memory-module connector until the memory module snaps into position and the securing clip locks in place.

i **NOTE:** The securing clips return to the locked position. If you do not hear the click, remove the memory module and reinstall it.

i **NOTE:** Repeat step 1 to step 3 when installing more than one memory module in your computer.

Next steps

1. Install the [hard-drive bracket](#).
2. Install the [2.5-inch hard drive](#) or [3.5-inch hard drive](#), whichever applicable.
3. Install the [front cover](#).
4. Install the [side cover](#).
5. Follow the procedure in [after working inside your computer](#).

Hard Drive

Removing the 2.5-inch hard drive

Prerequisites

1. Follow the procedure in [before working inside your computer](#).
2. Remove the [side cover](#).
3. Remove the [front cover](#).

About this task

The following images indicate the location of the 2.5-inch hard drive assembly and provide a visual representation of the removal procedure.



1x
6-32

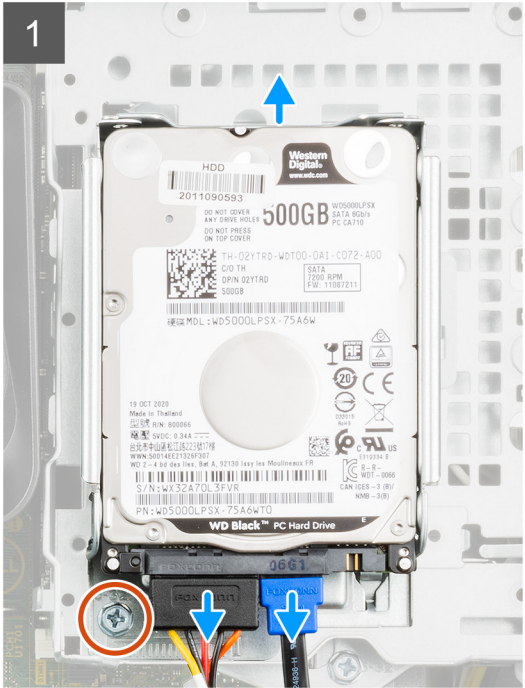
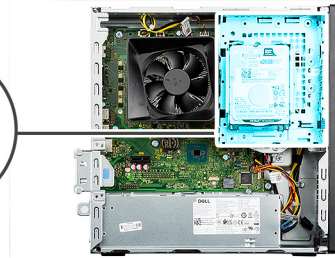



8x
M3x3

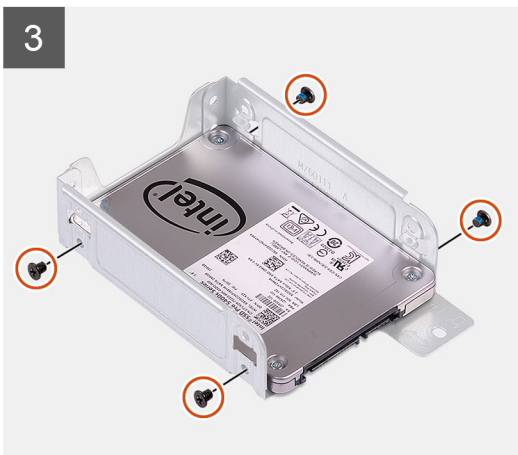
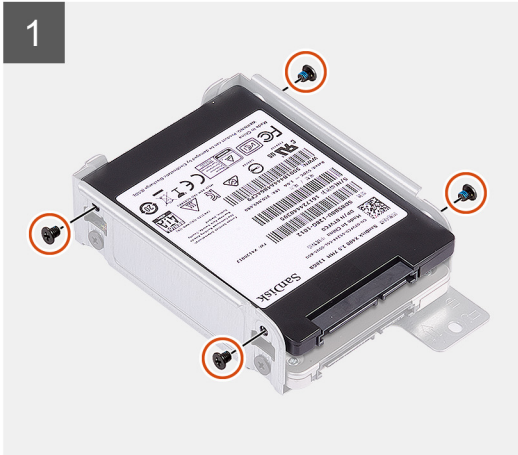

Steps

1. Disconnect the data and power cables from the 2.5-inch hard drive.
2. Remove the single (#6-32) screw that secures the 2.5-inch hard-drive assembly to the hard-drive bracket.
3. Slide and lift the hard-drive assembly upwards to release it from the slots on the hard-drive bracket.
4. Remove the four (M3x3) screws that secure the 2.5-inch hard drive to the hard-drive cage.
i **NOTE:** If your system configuration has two 2.5-inch hard drives, you have to remove eight (M3x3) screws.
5. Slide and remove the 2.5-inch hard drive from the hard-drive cage.

Installing the 2.5-inch hard drive

Prerequisites

If you are replacing a component, remove the existing component before performing the installation procedure.

About this task

The following images indicate the location of the 2.5-inch hard drive and provide a visual representation of the installation procedure:



8x
M3x3

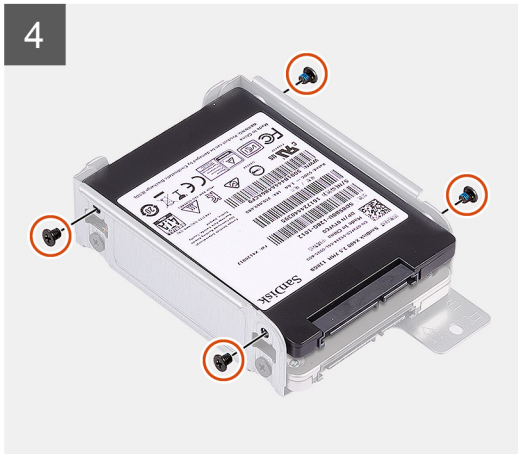
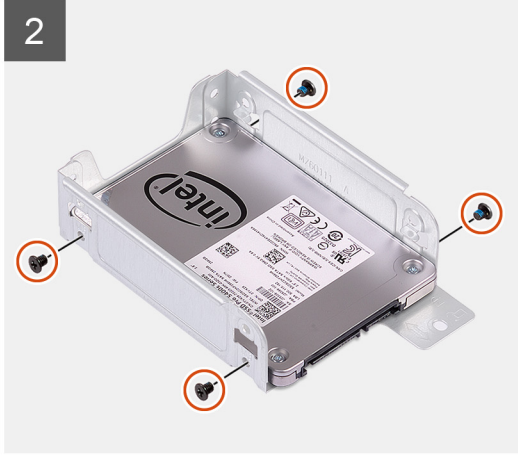



1x
6-32

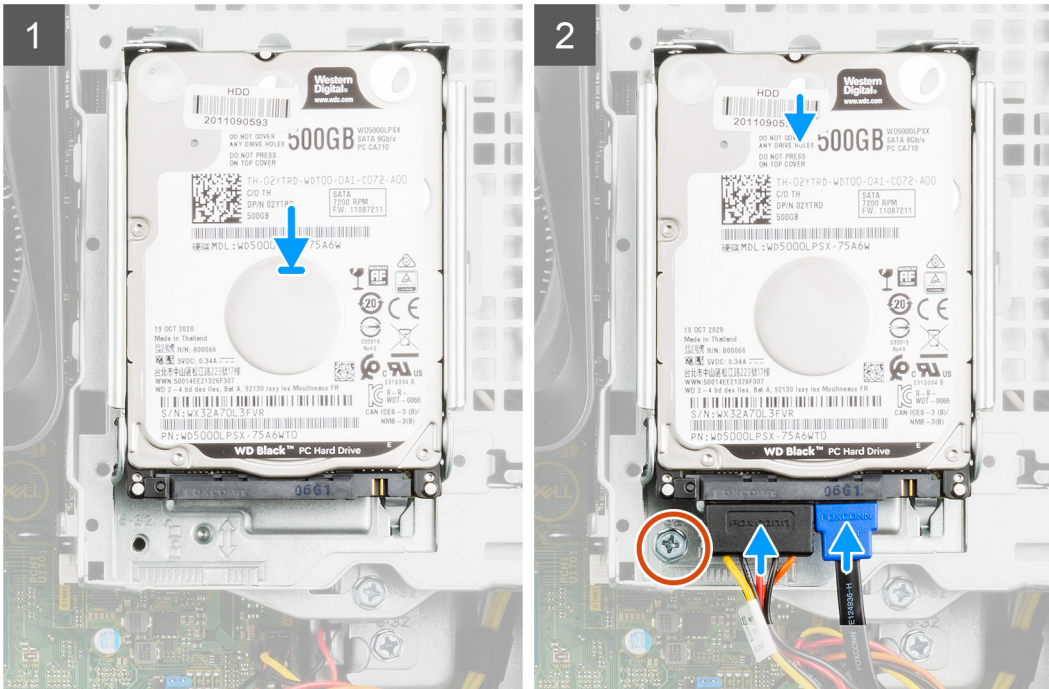
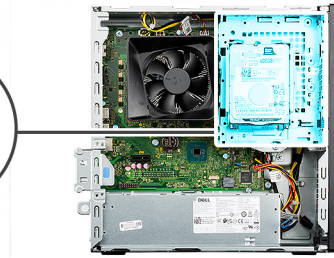

Steps

1. Slide the 2.5-inch hard drive into the hard-drive cage.
2. Replace the four (M3x3) screws to secure the 2.5-inch hard drive to the hard-drive cage.
i **NOTE:** If your system configuration has two 2.5-inch hard drives, you have to replace eight (M3x3) screws.
3. Align the tabs of the hard-drive assembly with the slots on the hard drive bracket.
4. Slide the hard-drive assembly into the hard drive bracket.
5. Replace the single (#6-32) screw to secure the 2.5-inch hard-drive assembly to the hard-drive bracket.
6. Connect the power cable and data cable to the 2.5-inch hard drive.

Next steps

1. Install the [front cover](#).
2. Install the [side cover](#).
3. Follow the procedure in [after working inside your computer](#).

Removing the 3.5-inch hard drive

Prerequisites

1. Follow the procedure in [before working inside your computer](#).
2. Remove the [side cover](#).
3. Remove the [front cover](#).

About this task

The following images indicate the location of the 3.5-inch hard drive assembly and provide a visual representation of the removal procedure.



2x
6-32

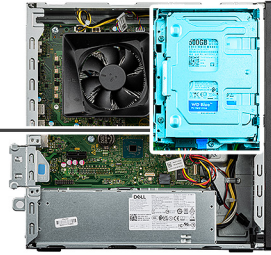



2x
6-32

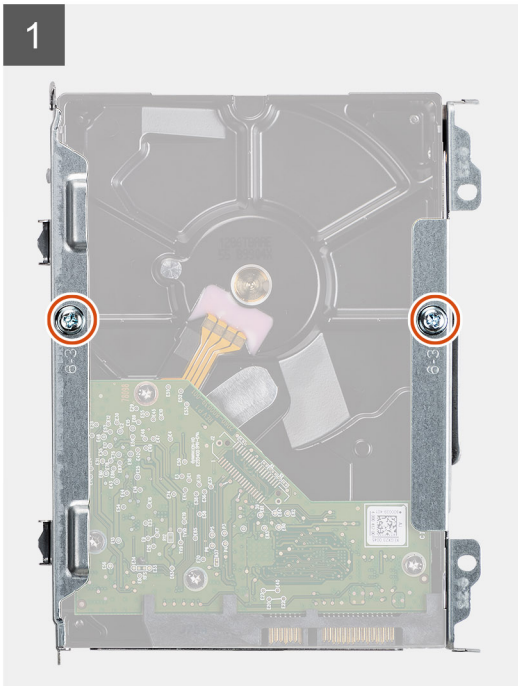

Steps

1. Disconnect the data and power cables from the 3.5-inch hard drive.
2. Remove the two (#6-32) screws that secure the 3.5-inch hard-drive assembly to the hard-drive bracket.
3. Slide and lift the hard-drive assembly.
4. Remove the two (#6-32) screws that secure the 3.5-inch hard drive to the hard-drive cage.
5. Slide and remove the 3.5-inch hard drive from the hard-drive cage.

Installing the 3.5-inch hard drive

Prerequisites

If you are replacing a component, remove the existing component before performing the installation procedure.

About this task

The following images indicate the location of the 3.5-inch hard drive assembly and provide a visual representation of the installation procedure.



2x
6-32

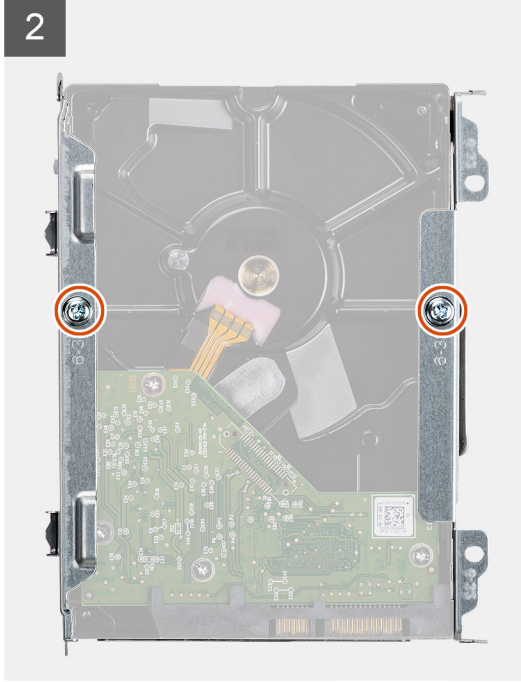
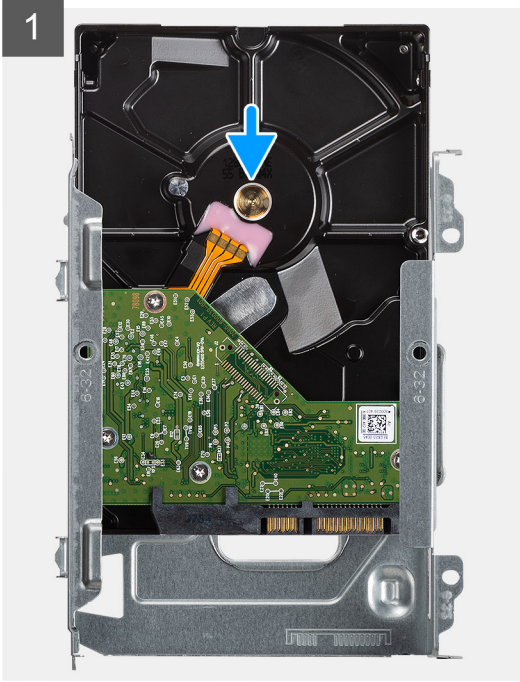



2x
6-32

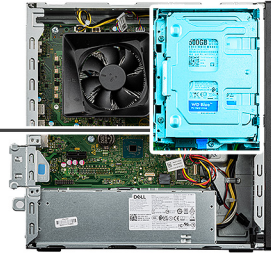

Steps

1. Align and slide the 3.5-inch hard drive into the hard-drive cage.
2. Replace the two (#6-32) screws to secure the 3.5-inch hard drive to the hard-drive cage.
3. Align and slide the hard drive assembly into the hard-drive bracket.
4. Replace the two (#6-32) screws to secure the 3.5-inch hard drive assembly to the hard-drive bracket.
5. Connect the power cable and data cables to the 3.5-inch hard drive.

Next steps

1. Install the [front cover](#).
2. Install the [side cover](#).
3. Follow the procedure in [after working inside your computer](#).

Hard-drive bracket

Removing the hard-drive bracket

Prerequisites

1. Follow the procedure in [before working inside your computer](#).
2. Remove the [side cover](#).
3. Remove the [front cover](#).
4. Remove the [2.5 inch hard drive](#) or [3.5-inch hard drive](#), whichever applicable.

About this task

The following image indicates the location of the hard drive bracket and provides a visual representation of the removal procedure.



1x
6-32

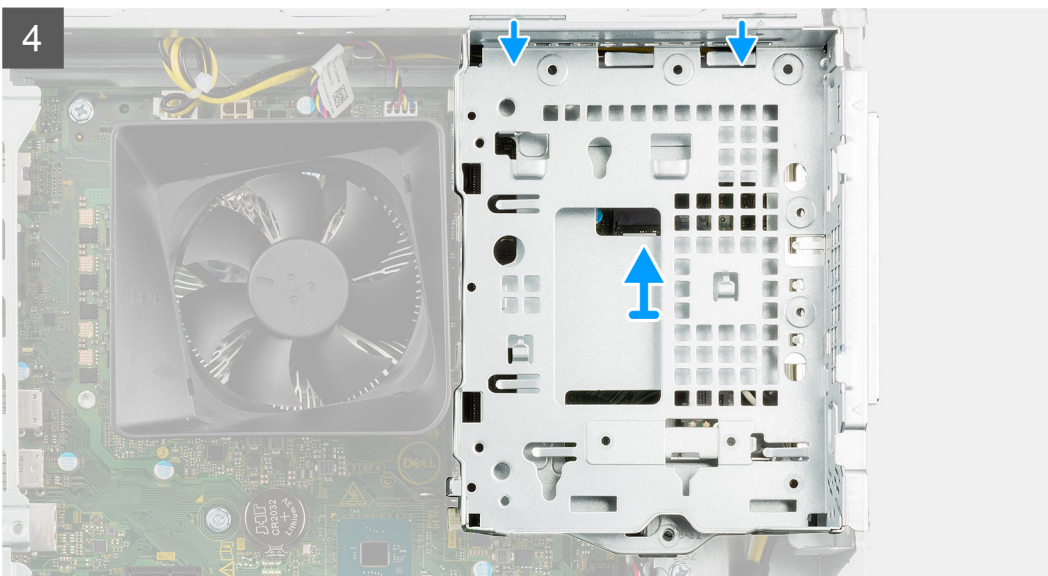
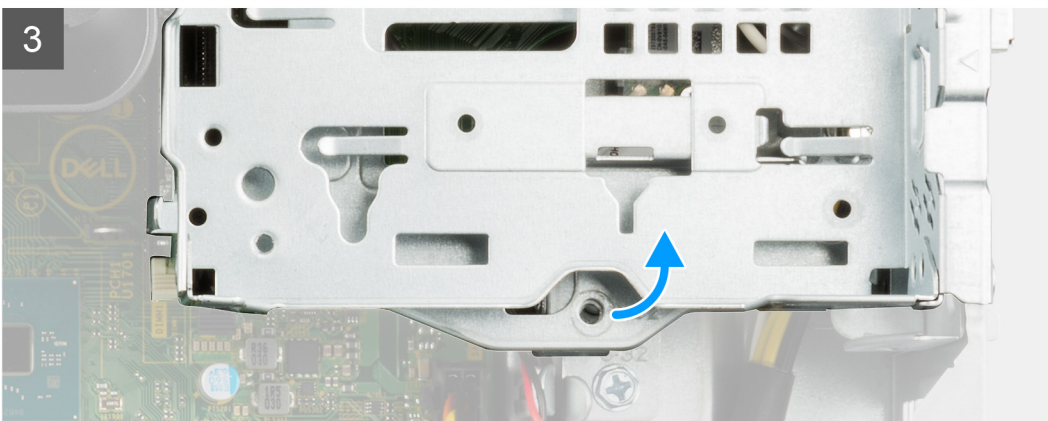
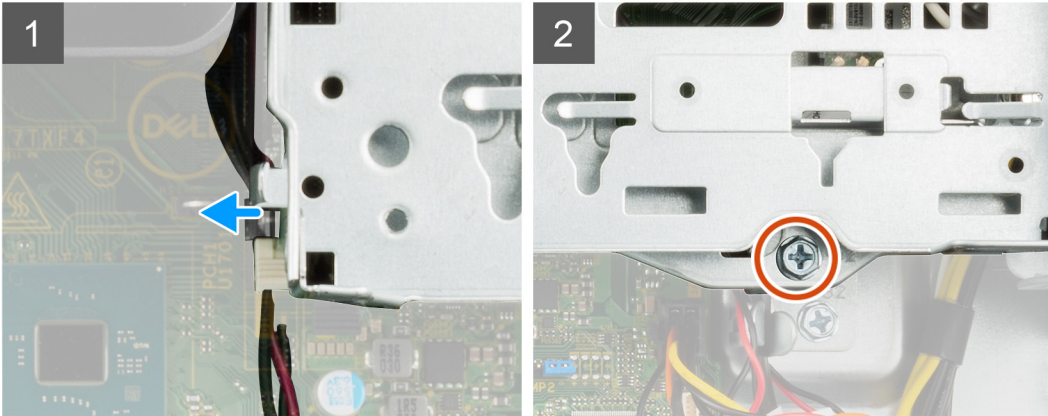

Steps

1. Unroute the power and SATA cables from the routing guides on hard-drive bracket.
2. Remove the single (#6-32) screw securing the hard drive-bracket to the chassis.
3. Lift the hard-drive bracket from the chassis.
4. Remove the hard-drive bracket from the chassis.

Installing the hard-drive bracket

Prerequisites

If you are replacing a component, remove the existing component before performing the installation procedure.

About this task

The following images indicate the location of the hard-drive bracket and provide a visual representation of the installation procedure:



1x
6-32

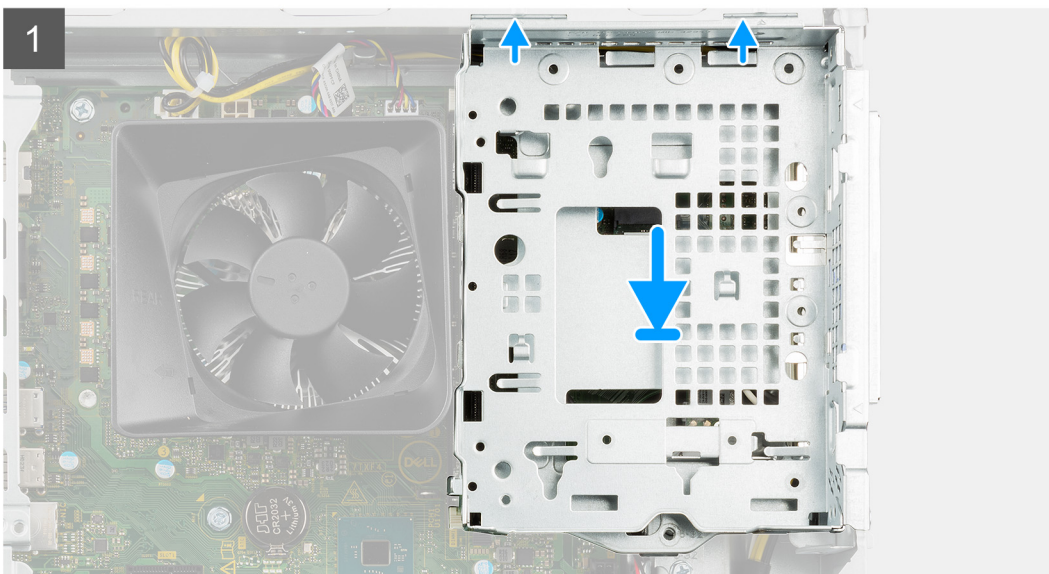

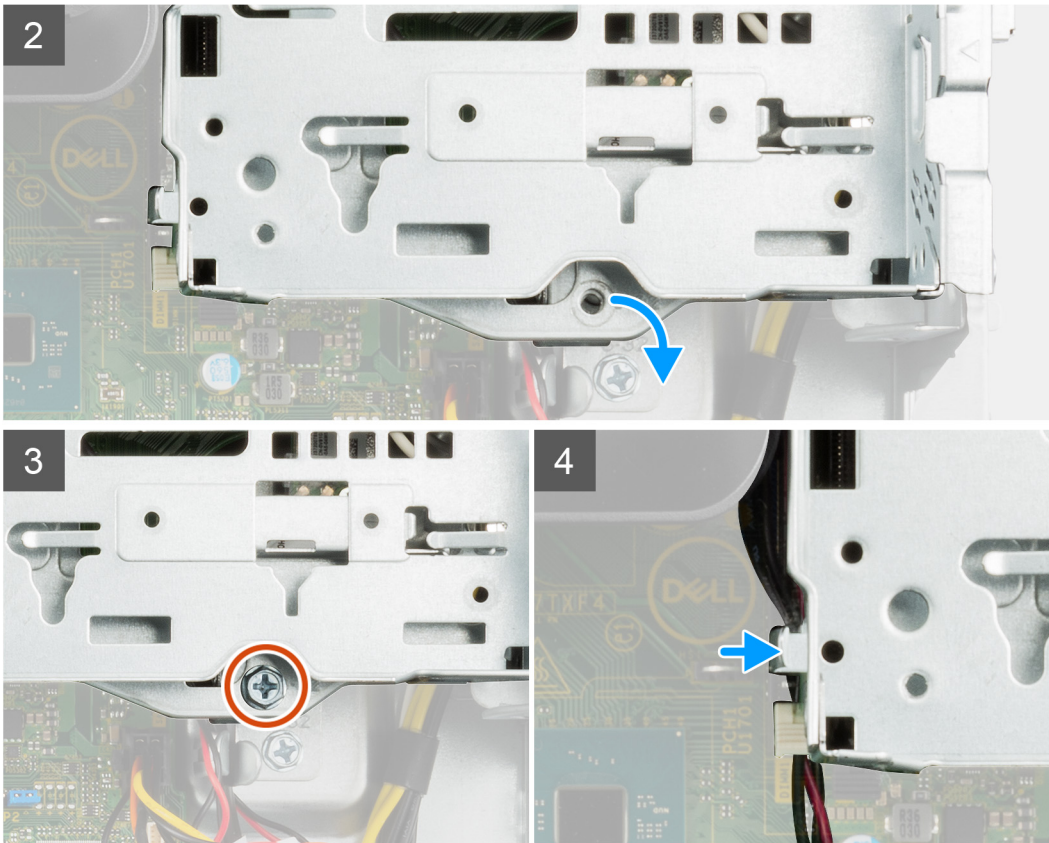

Steps

1. Insert the tabs on the hard-drive bracket into the slot on the system at 30-degree angle.
2. Lower the hard-drive bracket so that it is placed in its slot.
3. Replace the single (#6-32) screw securing the hard-drive bracket to the chassis.
4. Route the power and SATA cables along the routing guides on the hard-drive bracket.

Next steps

1. Install the [2.5-inch hard drive](#) or [3.5 in. hard drive](#), whichever applicable.
2. Install the [front cover](#).
3. Install the [side cover](#).
4. Follow the procedure in [After working inside your computer](#).

Solid-state drive

Removing the solid-state drive

Prerequisites

1. Follow the procedure in [before working inside your computer](#).
2. Remove the [side cover](#).
3. Remove the [front cover](#).
4. Remove the [2.5-inch hard drive](#) or [3.5-inch hard drive](#), whichever applicable.
5. Remove the [hard-drive bracket](#).

About this task

 **NOTE:** Depending on the configuration ordered, your computer may come with one of the following modules installed:

- M.2 2230 solid-state drive
- M.2 2280 solid-state drive

The following images indicate the location of the M.2 2230 solid-state drive and provide a visual representation of the removal procedure.



1x
M2x3.5



1 M.2 2280



2

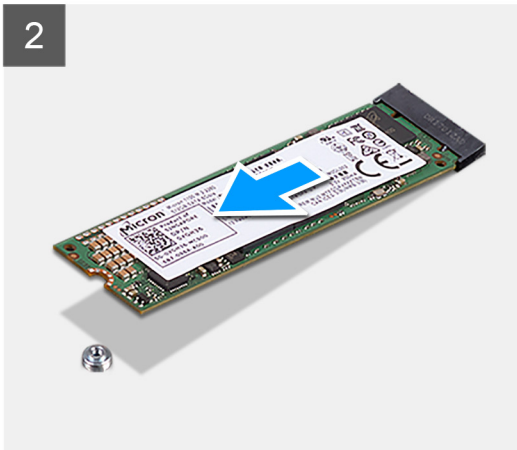

M.2 2230

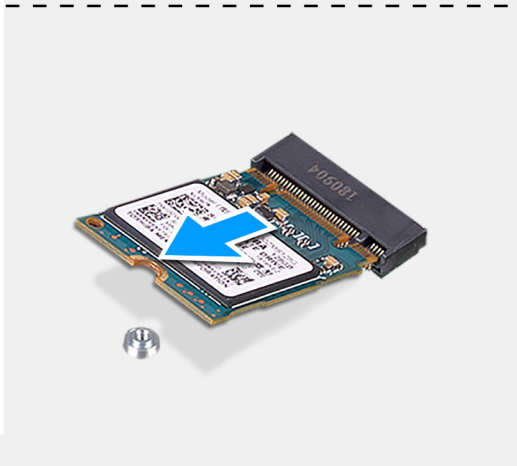

Steps

1. Remove the screw (M2x3.5) that secures the solid-state drive to the system board.
2. Slide and lift the solid-state drive from the M.2 card slot on the system board.

Installing the solid-state drive

Prerequisites

If you are replacing a component, remove the existing component before performing the installation process.

About this task

NOTE: Depending on the configuration ordered, your computer may come with one of the following modules installed:

- M.2 2230 solid-state drive
- M.2 2280 solid-state drive

The following image indicates the location of the solid-state drive and provides a visual representation of the installation procedure.



1x
M2x3.5

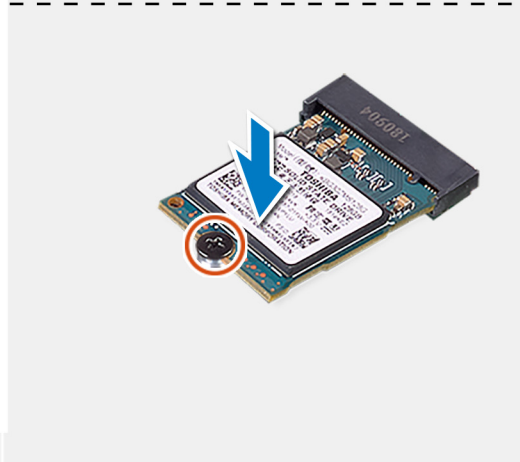
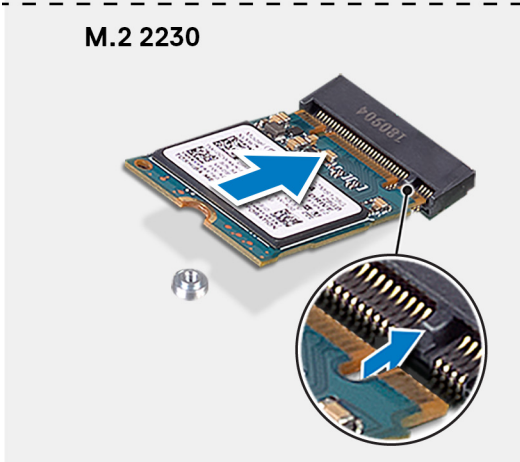
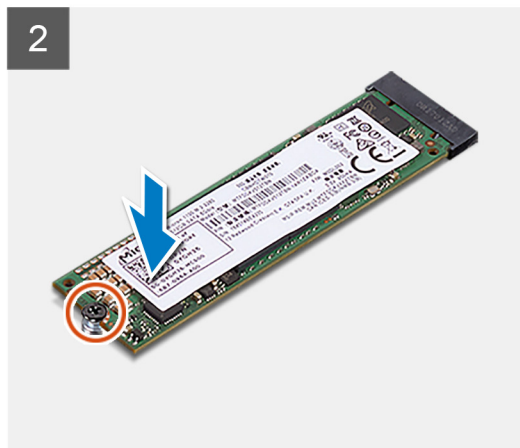
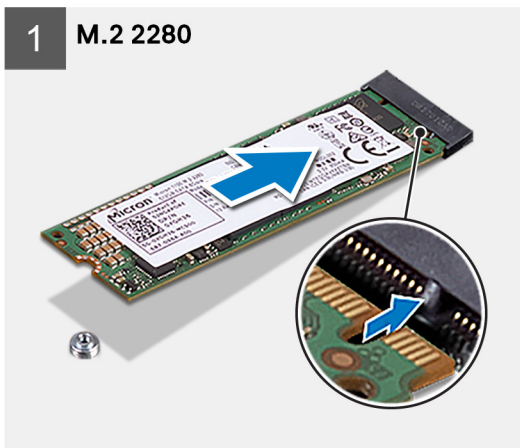

Steps

1. Align the notch on the solid-state drive with the tab on the M.2 card slot.
2. Slide the solid-state drive into the M.2 card slot on the system board.
3. Replace the screw (M2x3.5) to secure the solid-state drive to the system board depending on the type of solid-state drive (M.2 2230/ M.2 2280).

Next steps

1. Install the [hard-drive bracket](#).
2. Install the [2.5-inch hard drive](#) or [3.5-inch hard drive](#), whichever applicable.
3. Install the [front cover](#).
4. Install the [side cover](#).
5. Follow the procedure in [after working inside your computer](#).

Coin-cell battery

Removing the coin-cell battery

Prerequisites

1. Follow the procedure in [Before working inside your computer](#).
2. Remove the [Side cover](#).

About this task

- NOTE:** Removing the coin-cell battery resets the BIOS setup program's settings to default. It is recommended that you note the BIOS setup program's settings before removing the battery.
- NOTE:** After a service incident where the system board is replaced, or when the coin-cell battery is replaced an RTC reset cycle will occur. When an RTC Reset cycle occurs, the computer turns on and off three times. An "Invalid Configuration" error message is displayed prompting you to enter the BIOS and configure the date and time. The computer starts functioning normally after setting the date and time.

The following images indicate the location of the coin-cell battery and provide a visual representation of the removal procedure.

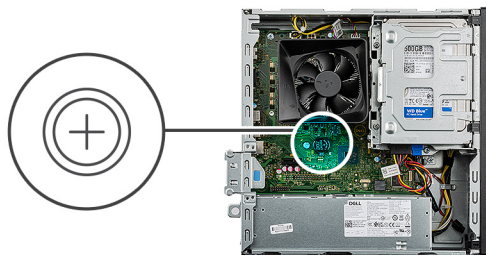

Steps

1. Using a plastic scribe, push the coin-cell battery securing-clip on the coin-cell battery socket to release the coin-cell battery out of the slot on the system board.
2. Lift the coin-cell battery off its slot on the system board.

Installing the coin-cell battery

Prerequisites

If you are replacing a component, remove the existing component before performing the installation procedure.

About this task

The following images indicate the location of the coin-cell battery and provide a visual representation of the installation procedure.

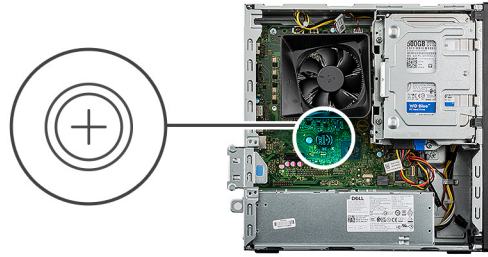

Steps

1. Insert the coin-cell battery into its slot on the system board with the positive side (+) label facing up.
2. Press down on the coin-cell battery into the slot on the system board.

Next steps

1. Install the [side cover](#).
2. Follow the procedure in [after working inside your computer](#).

Wireless card

Removing the wireless card

Prerequisites

1. Follow the procedure in [before working inside your computer](#).
2. Remove the [side cover](#).
3. Remove the [front cover](#).
4. Remove the [hard-drive bracket](#).

About this task

The following images indicate the location of the wireless card and provide a visual representation of the removal procedure.



1x
M2x3

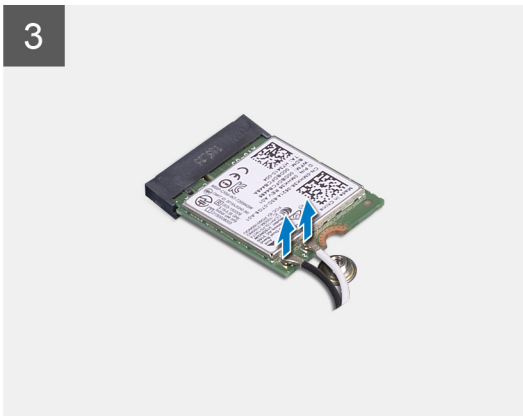
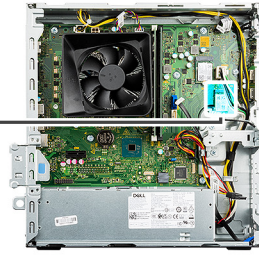

Steps

1. Remove the screw (M2x3) that secures the wireless card to the system board.
2. Slide and lift the wireless-card bracket off the wireless card.
3. Disconnect the antenna cables from the wireless card.
4. Slide and remove the wireless card at an angle from the wireless-card slot.

Installing the wireless card

Prerequisites

If you are replacing a component, remove the existing component before performing the installation process.

About this task

The following image indicates the location of the wireless card and provides a visual representation of the installation procedure.



1x
M2x3

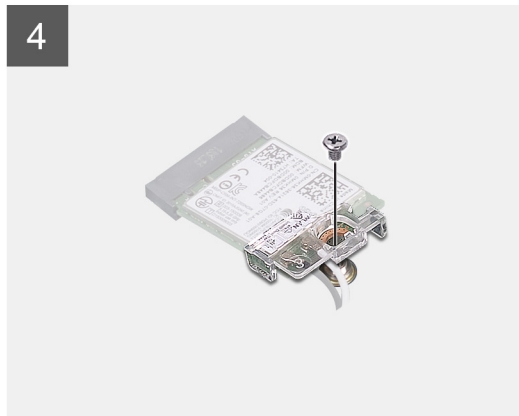
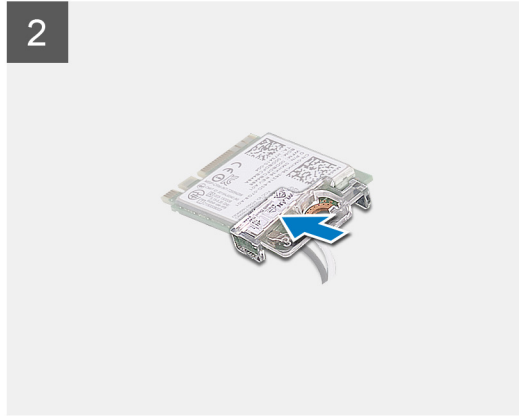
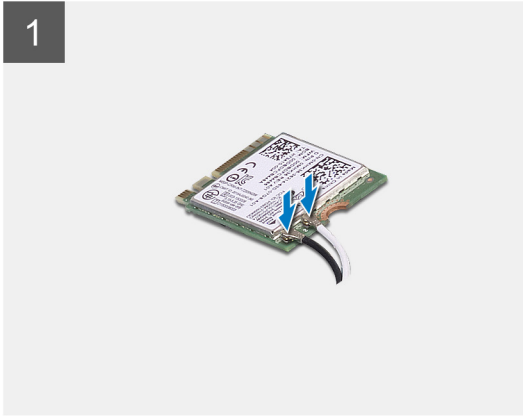
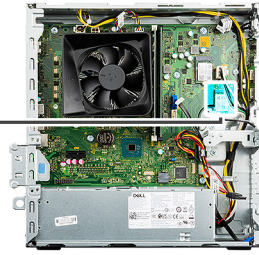

Steps

1. Connect the antenna cables to the wireless card.
The following table provides the antenna-cable color scheme for the wireless card of your computer.

Table 2. Antenna-cable color scheme

| Connectors on the wireless card | Antenna-cable color |
|---------------------------------|---------------------|
| Main (white triangle) | White |
| Auxiliary (black triangle) | Black |

2. Slide and place the wireless-card bracket on the wireless card.
3. Align the notch on the wireless card with the tab on the wireless-card slot.
4. Slide the wireless card at an angle into the wireless-card slot.
5. Replace the screw (M2x3) that secures the wireless card to the system board.

Next steps

1. Install the [hard-drive bracket](#).
2. Install the [front cover](#).
3. Install the [side cover](#).
4. Follow the procedure in [After working inside your computer](#).

Power-supply unit

Removing the power-supply unit

Prerequisites

1. Follow the procedure in [before working inside your computer](#).
2. Remove the [side cover](#).
3. Remove the [front cover](#).
4. Remove the [hard-drive bracket](#).

NOTE: Note the routing of all cables as you remove them so that you can route them correctly while you are replacing the power-supply unit.

About this task

The following images indicate the location of the power-supply unit and provide a visual representation of the removal procedure.



6x
6x32

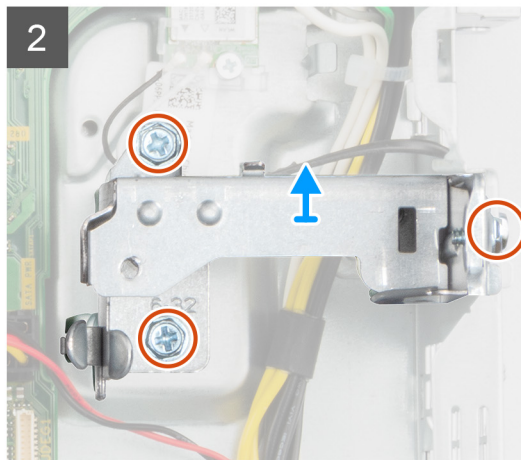
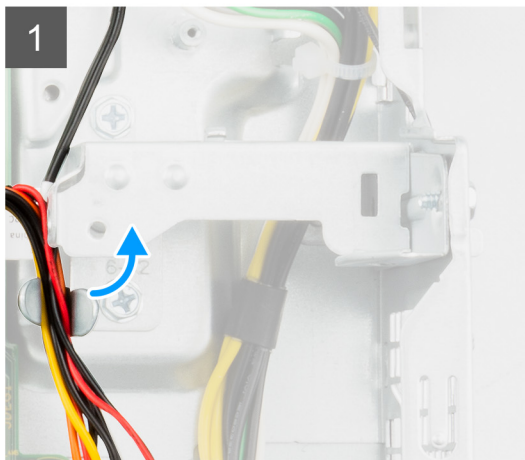

3





Steps

1. Unroute the power supply cables from their routing guides on the chassis.
2. Remove the three (#6-32) screws that secure the metal bracket.
3. Lift the metal bracket away from the chassis.
4. Disconnect the power cables from the system board.
 - i NOTE:** The power-supply cable is connected to the system board at two locations and supply power to the following components:
 - Processor - ATX CPU connector
 - System board - ATX SYS connector
5. Remove the three (#6-32) screws that secure the power-supply to the chassis.
6. Slide the power-supply unit towards the front to release it from the slots on the computer chassis.
7. Slide and lift the power supply from its slot on the chassis.

Installing the power-supply unit

Prerequisites

If you are replacing a component, remove the existing component before performing the installation procedure.

⚠ WARNING: The cables and ports on the back of the power-supply unit are color-coded to indicate the different power wattage. Ensure that you plug in the cable to the correct port. Failure to do so may result in damaging the power-supply unit and/or system components.

About this task

The following images indicate the location of the power-supply unit and provide a visual representation of the installation procedure.



6x
6x32

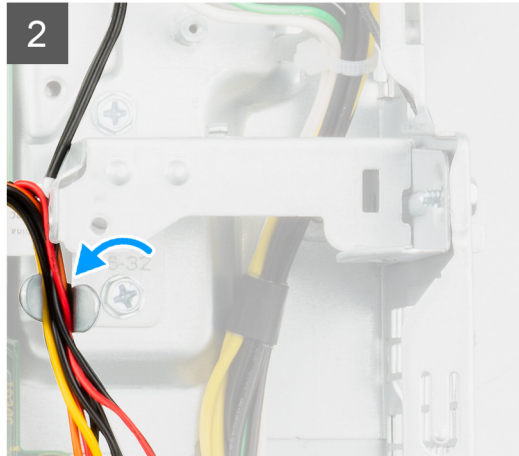
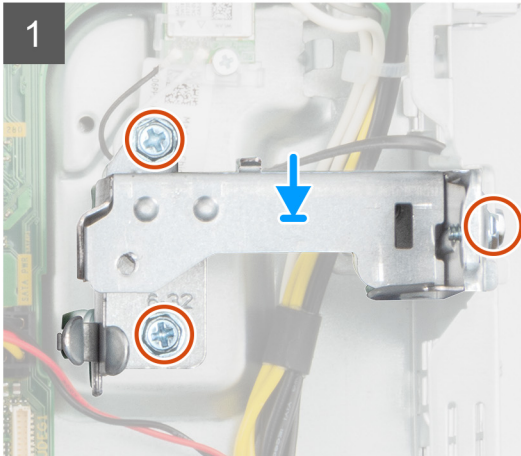

3



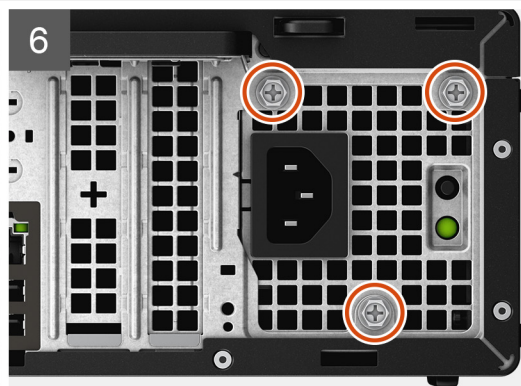
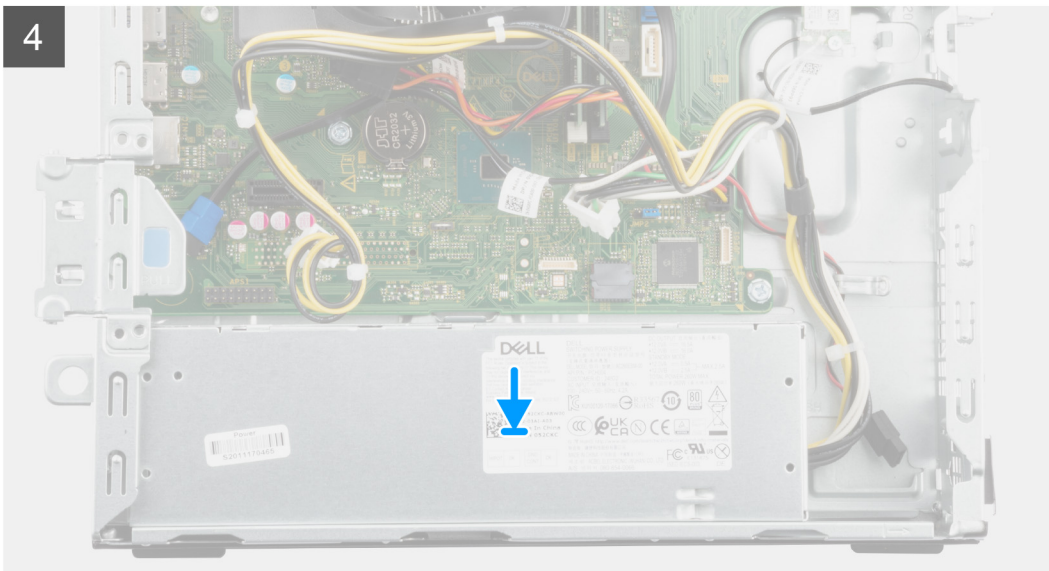

Steps

1. Place the metal bracket into the chassis so that the screw holes are aligned.
2. Replace the three (#6-32) screws to secure the metal bracket to the chassis.
3. Route the power cables through the routing clip on the metal bracket.
4. Route the power cables through the routing guides on the chassis.
5. Connect the power cables to the system board.
 - i NOTE:** The power-supply cable is connected to the system board at two locations and supply power to the following components:
 - Processor - ATX CPU connector
 - System board - ATX SYS connector
6. Place and slide the power-supply unit into the chassis until the securing tab snaps into position.
7. Replace the three (#6-32) screws to secure the power-supply unit to the chassis.

Next steps

1. Install the [hard-drive bracket](#).
2. Install the [front cover](#).
3. Install the [Side cover](#).
4. Follow the procedure in [After working inside your computer](#).

Fan and heat-sink assembly

Removing the fan and heat-sink assembly

Prerequisites

1. Follow the procedure in [before working inside your computer](#).
2. Remove the [side cover](#).
3. Remove the [front cover](#).
4. Remove the [hard-drive bracket](#).

About this task

CAUTION: The heat sink may become hot during normal operation. Allow sufficient time for the heat sink to cool before touching it.

CAUTION: For maximum cooling of the processor, do not touch the heat transfer areas on the heat sink. The oils in your skin can reduce the heat transfer capability of the thermal grease.

The following images indicate the location of the fan and heat-sink, and provide a visual representation of the removal procedure.

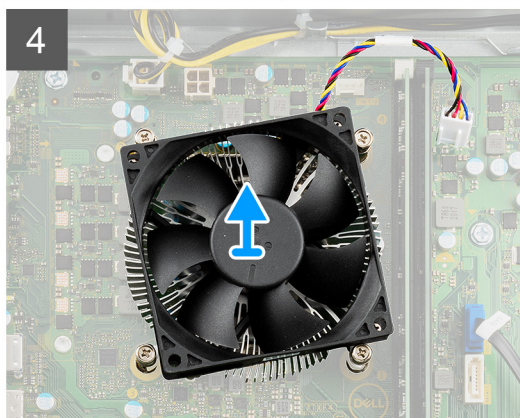
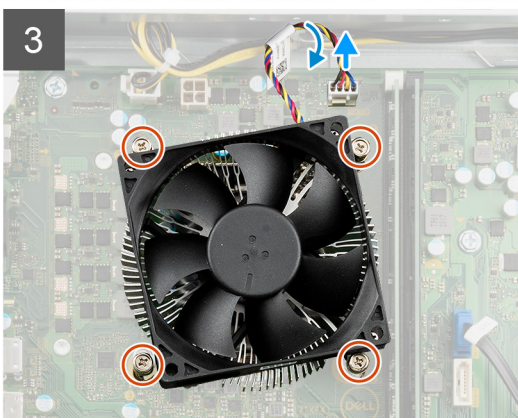
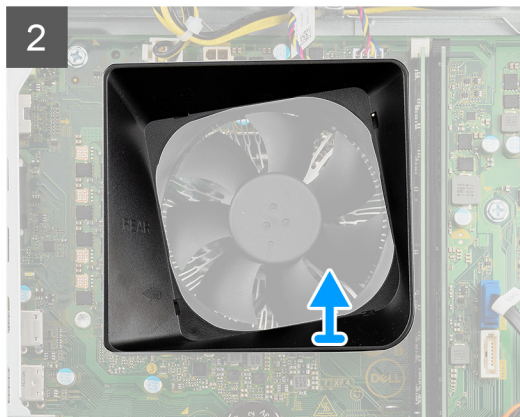
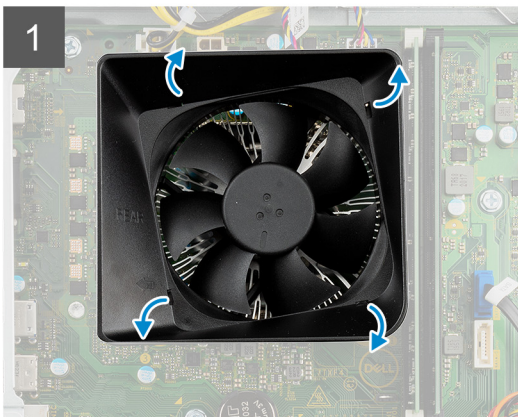
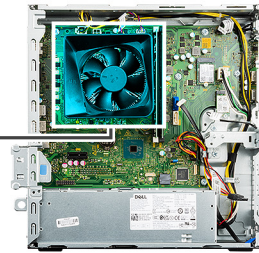

Steps

1. Gently pull the grommets to release the fan shroud from the fan and heat sink assembly .
2. Lift the fan shroud away from the chassis.
3. Disconnect the fan cable from the system board.
4. In a reverse sequential order (4>3>2>1) loosen the four captive screws (M3) that secure the fan and heat-sink assembly to the system board.
5. Lift the fan and heat-sink assembly off the system board.

Installing the fan and heat-sink assembly

Prerequisites

If you are replacing a component, remove the existing component before performing the installation process.

About this task

i **NOTE:** If either the processor or the fan and heat-sink assembly is replaced, use the thermal grease provided in the kit to ensure that thermal conductivity is achieved.

The following image indicates the location of the fan and heat-sink assembly, and provides a visual representation of the installation procedure.

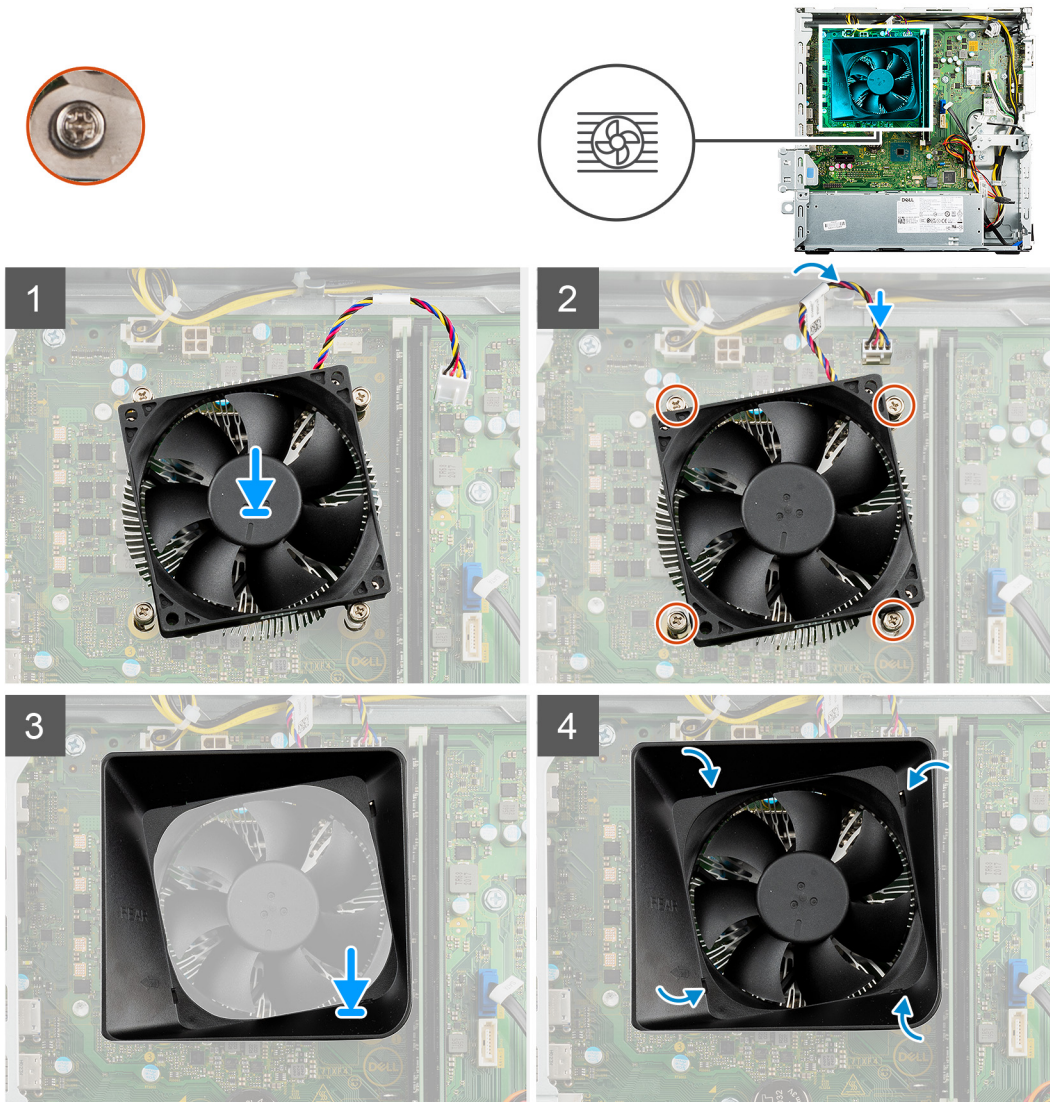

Steps

1. Gently place the fan and heat-sink assembly on the system board.
2. Align the screw holes on the fan and heat-sink assembly with the screw holes on the system board.
3. In sequential order (1>2>3>4) tighten the four captive screws that secure the fan and heat-sink assembly to the system board.
4. Connect the fan cable to the connector on the system board.
5. Place the fan shroud into place on the fan and heat-sink assembly and snap it into place.

Next steps

1. Install the [hard-drive bracket](#).
2. Install the [front cover](#).
3. Install the [side cover](#).
4. Follow the procedure in [after working inside your computer](#).

Processor

Removing the processor

Prerequisites

1. Follow the procedure in [before working inside your computer](#).
2. Remove the [side cover](#).
3. Remove the [front cover](#).
4. Remove the [hard-drive bracket](#).
5. Remove the [fan and heat-sink assembly](#).

 **CAUTION:** The processor may become hot during normal operation. Allow sufficient time for the processor to cool before you touch it.

 **CAUTION:** For maximum cooling of the processor, do not touch the heat transfer areas on the heat sink. The oils in your skin can reduce the heat transfer capability of the thermal grease.

About this task

The following images indicate the location of the processor and provide a visual representation of the removal procedure.

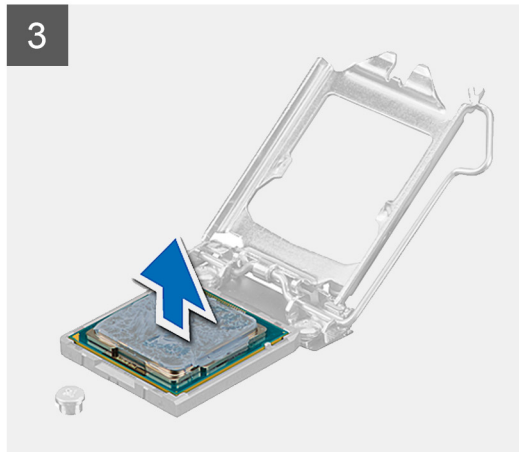
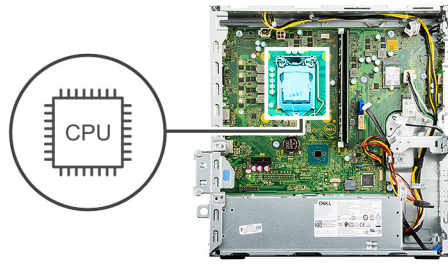

Steps

1. Press the release lever down and then push it away from the processor to release it from the securing tab.
2. Lift the lever upward to lift the processor cover.

 **CAUTION:** When removing the processor, do not touch any of the pins inside the socket or allow any objects to fall on the pins in the socket.

3. Extend the release lever completely and open the processor cover.
4. Gently lift the processor from its socket on the system board.

Installing the processor

Prerequisites

If you are replacing a component, remove the existing component before performing the installation process.

About this task

 **NOTE:** If either the processor or the fan and heat-sink assembly is replaced, use the thermal grease that is provided in the kit to ensure that thermal conductivity is maintained.

The following image indicates the location of the processor and provides a visual representation of the installation procedure.

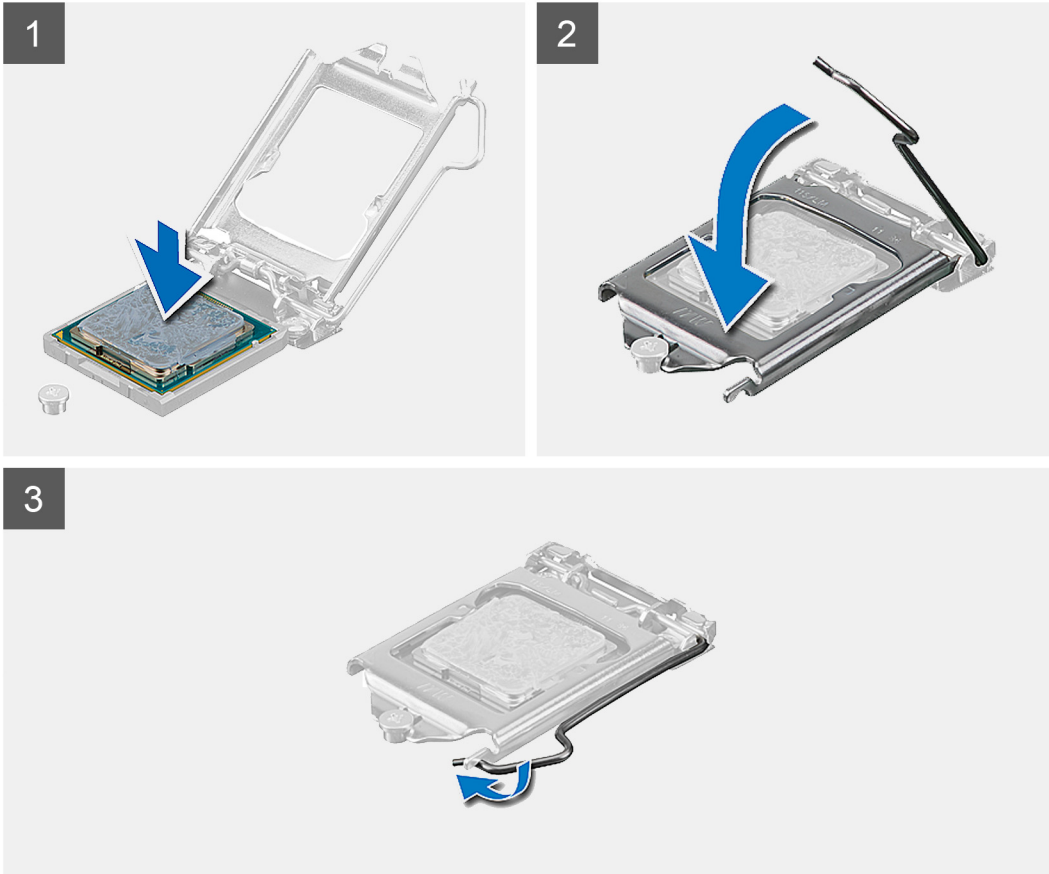
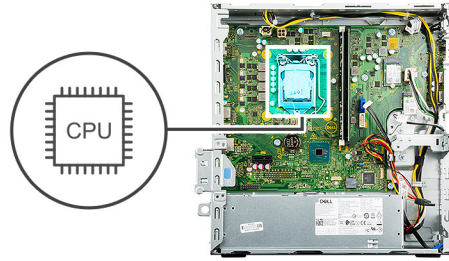

Steps

1. Ensure that the release lever on the processor socket is fully extended in the open position.

i **NOTE:** The pin-1 corner of the processor has a triangle that aligns with the triangle on the pin-1 corner on the processor socket. When the processor is properly seated, all four corners are aligned at the same height. If one or more corners of the processor are higher than the others, the processor is not seated properly.

2. Align the notches on the processor with the tabs on the processor socket and place the processor in the processor socket on the system board.

i **NOTE:** Ensure that the processor-cover notch is positioned underneath the alignment post.

3. When the processor is fully seated in the socket, pivot the release-lever down and place it under the tab on the processor cover.

Next steps

1. Install the [fan and heat-sink assembly](#).
2. Install the [hard-drive bracket](#).
3. Install the [front cover](#).
4. Install the [side cover](#).

5. Follow the procedure in [after working inside your computer](#).

Power button

Removing the power button

Prerequisites

1. Follow the procedure in [before working inside your computer](#).
2. Remove the [side cover](#).
3. Remove the [front cover](#).
4. Remove the [hard-drive bracket](#).

About this task

The following images indicate the location of the power button and provide a visual representation of the removal procedure.

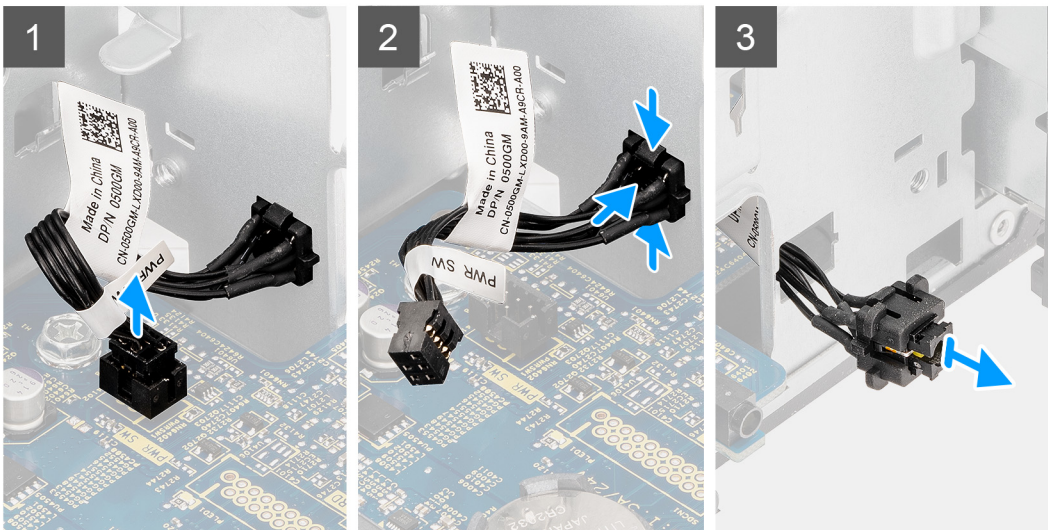

Steps

1. Disconnect the power button cable from the connector on the system board.
2. Press the release tabs on the power button and push it out of the chassis.
3. Remove the power button out from the chassis.

Installing the power button

Prerequisites

If you are replacing a component, remove the existing component before performing the installation procedure.

About this task

The following images indicate the location of the power button and provide a visual representation of the installation procedure.

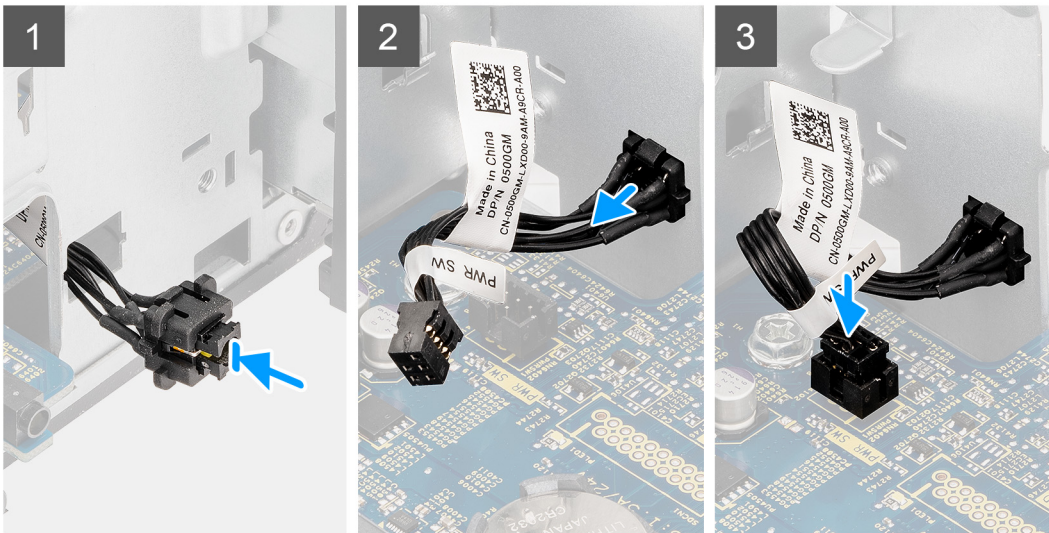

Steps

1. Insert the power button switch into the slot on the chassis.
2. Push the power button in until you hear a click from the retention tabs.
3. Connect the power button cable to the connector on the system board.

Next steps

1. Install the [hard-drive bracket](#).
2. Install the [front cover](#).
3. Install the [side cover](#).
4. Follow the procedure in [after working inside your computer](#).

System board

Removing the system board

Prerequisites

1. Follow the procedure in [before working inside your computer](#).
 - NOTE:** Your computer's Service Tag is stored in the system board. You must enter the Service Tag in the BIOS setup program after you replace the system board.
 - NOTE:** Replacing the system board removes any changes that you have made to the BIOS using the BIOS setup program. You must make the appropriate changes again after you replace the system board.
 - NOTE:** Before disconnecting the cables from the system board, note the location of the connectors so that you can reconnect the cables correctly after you replace the system board.

2. Remove the [side cover](#).
3. Remove the [front cover](#).
4. Remove the [2.5-inch hard drive](#) or [3.5-inch hard drive](#), whichever applicable.
5. Remove the [hard-drive bracket](#).
6. Remove the [solid-state drive](#).
7. Remove the [wireless card](#).
8. Remove the [power button](#).
9. Remove the [fan and heat-sink assembly](#).
10. Remove the [Processor](#)

About this task

The following image indicates the connectors on your system board:

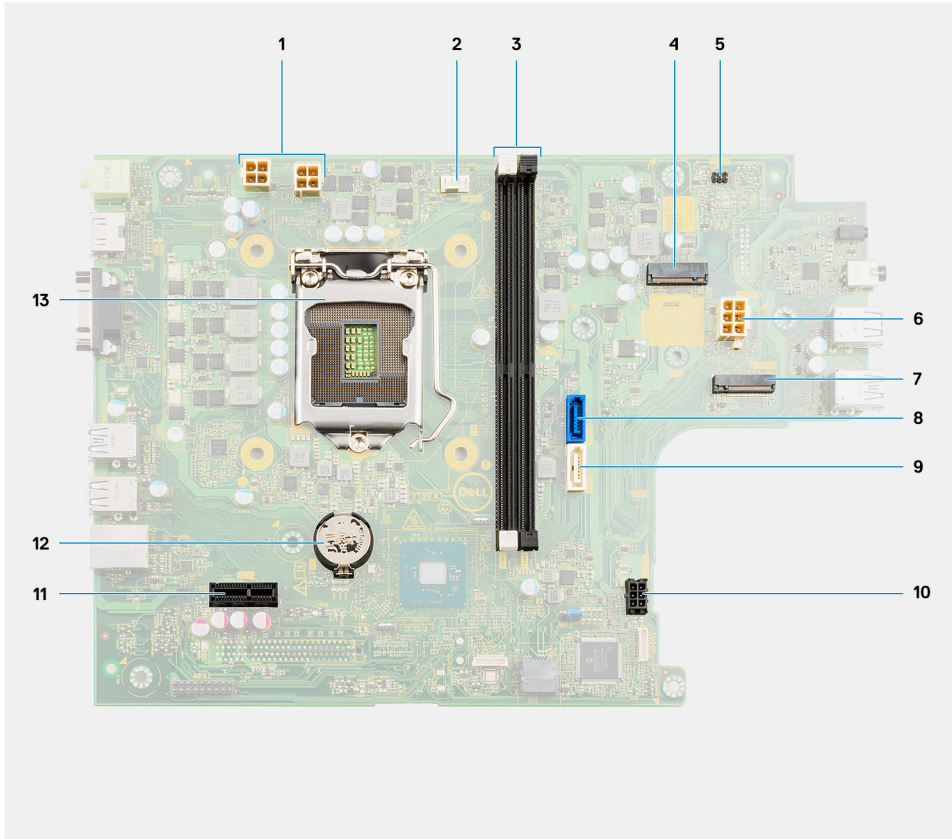

- | | |
|---|---|
| <ol style="list-style-type: none"> 1. Processor-power cable connector (ATX CPU) 3. Memory-module slot (DIMM 1 and 2) 5. Power-button cable connector (PWR SW) 7. M.2 card slot for wireless card (M.2 WLAN) 9. SATA cable connector 2 11. PCIe x1 expansion slot (SLOT1) 13. Processor | <ol style="list-style-type: none"> 2. Fan ad heat-sink cable connector (FAN CPU) 4. M.2 solid-state drive connector 6. System-board power cable connector (ATX SYS) 8. SATA cable connector 1 10. Hard-drive power cable connector (SATA PWR) 12. Coin-cell battery |
|---|---|

The following images indicate the location of the system board and provide a visual representation of the removal procedure.

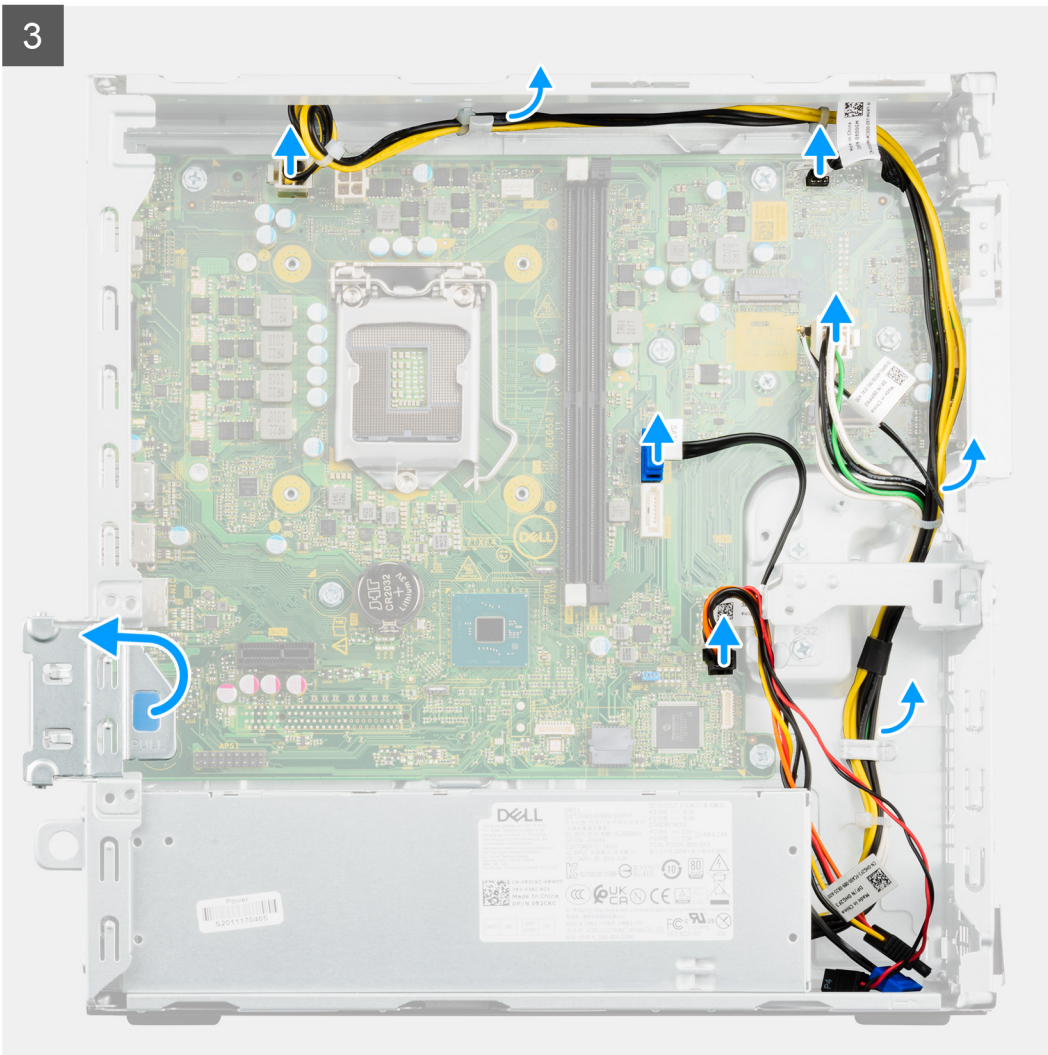
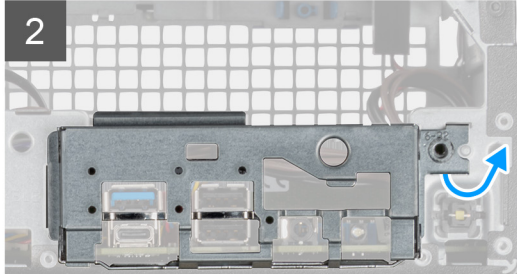
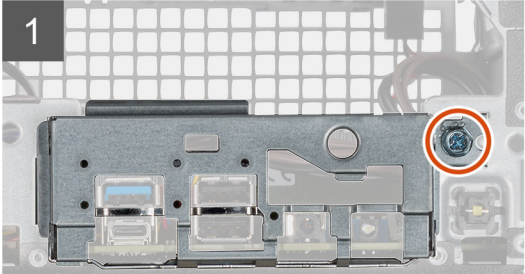
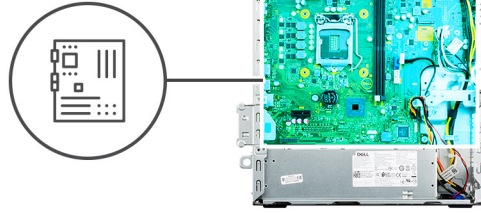
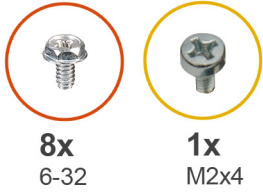

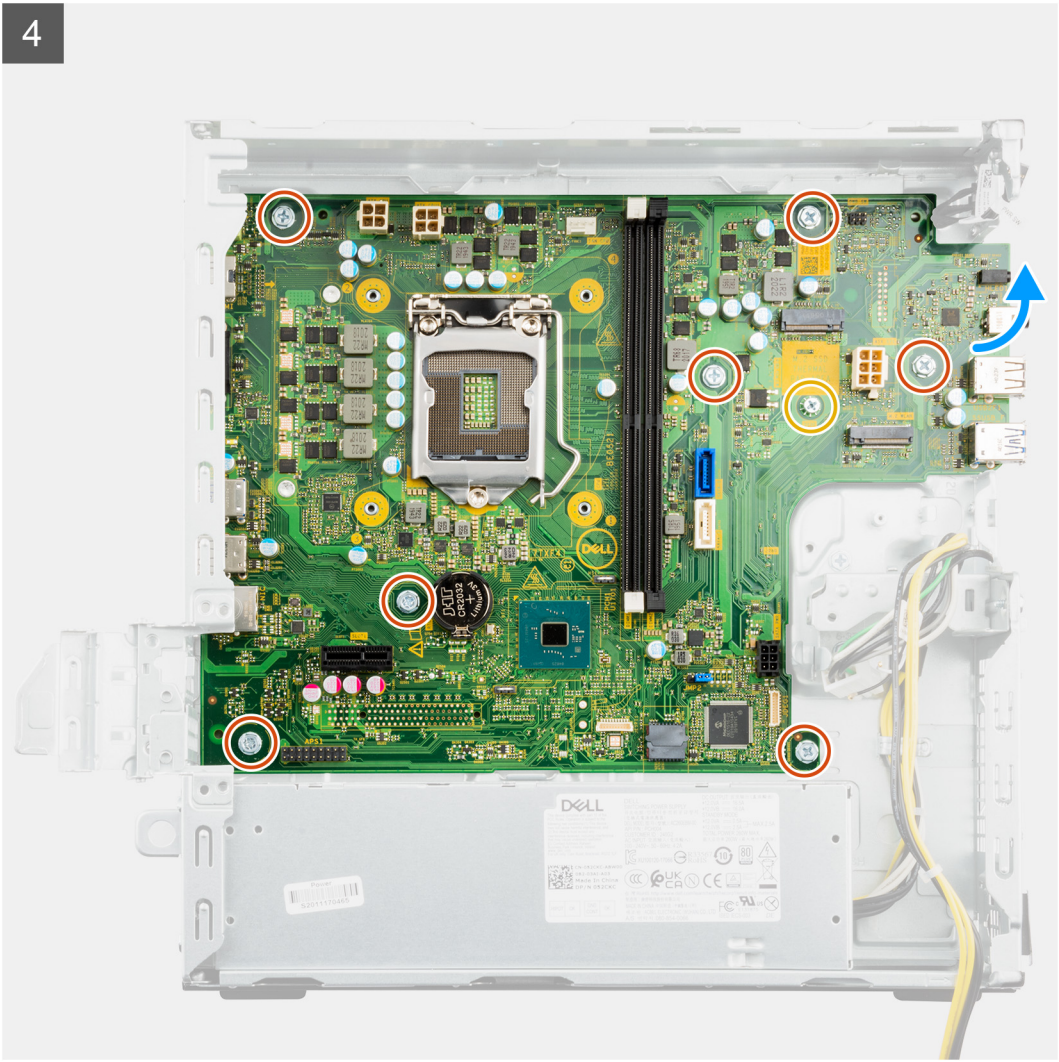

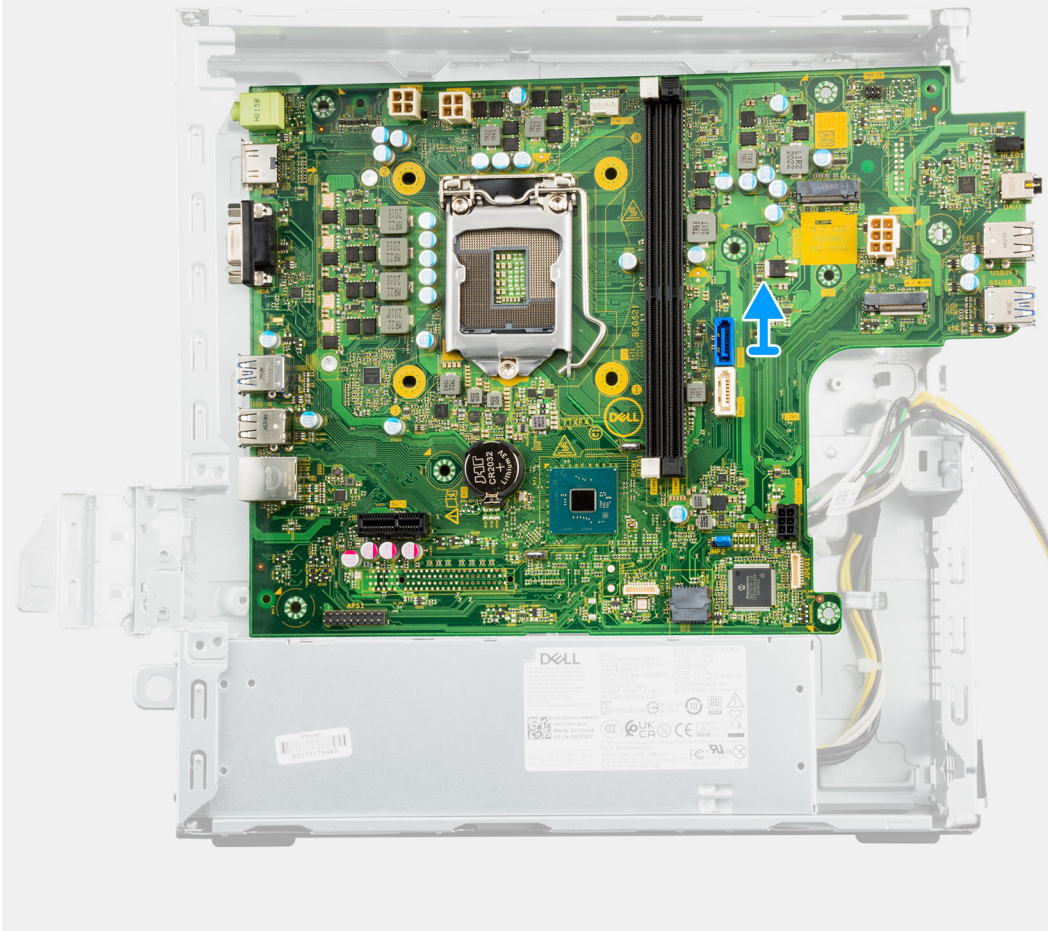

Steps

1. Disconnect the following cables that are connected to the system board and remove them from the routing points on the chassis:
 - Power-supply cables
 - Hard-drive SATA cables
 - Power-button cable
2. Remove the single screw (#6-32) that secures the front I/O-bracket to the chassis.
3. Slide and remove the front I/O-bracket from the chassis.
4. Remove the seven (#6-32) screws and one (M2x4) screw that secures the system board to the chassis.

i **NOTE:** Remove the single (M2x3.5) screw that secures the M.2 2230 solid-state drive to the system board (if not removed earlier).
5. Carefully lift the system board at an angle and remove the system board off the chassis.

Installing the system board

Prerequisites

If you are replacing a component, remove the existing component before performing the installation procedure.

About this task

The following image indicates the connectors on your system board:

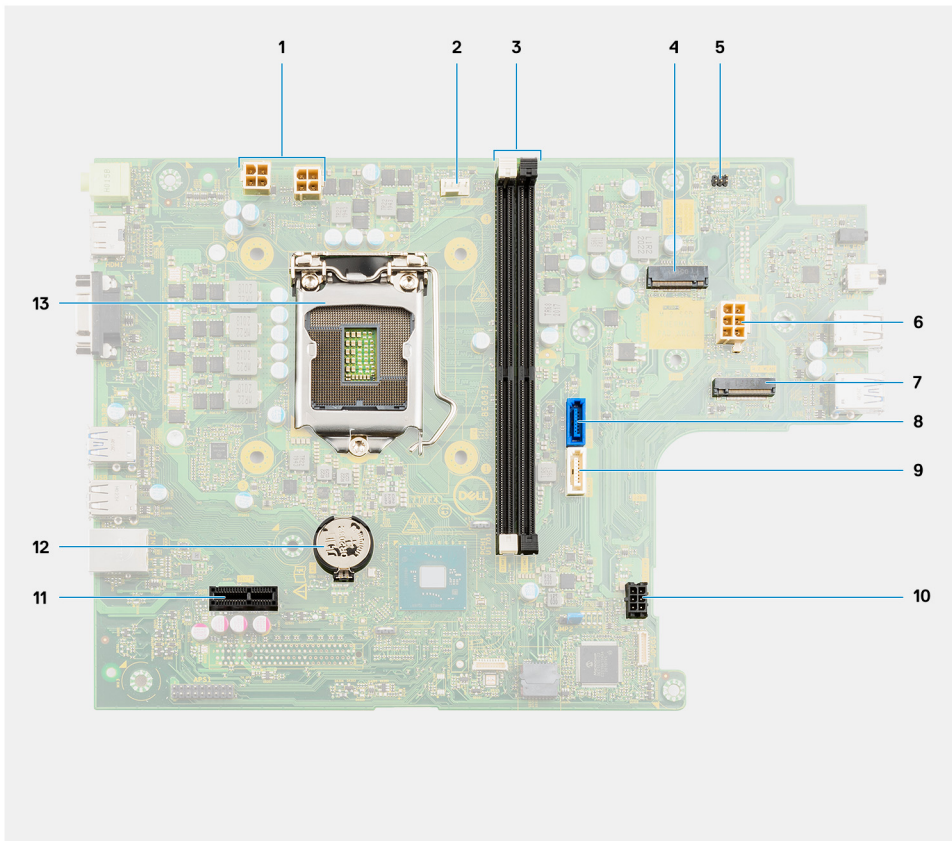

- | | |
|---|---|
| 1. Processor-power cable connector (ATX CPU) | 2. Fan and heat-sink cable connector (FAN CPU) |
| 3. Memory-module slot (DIMM 1 and 2) | 4. M.2 solid-state drive connector |
| 5. Power-button cable connector (PWR SW) | 6. System-board power cable connector (ATX SYS) |
| 7. M.2 card slot for wireless card (M.2 WLAN) | 8. SATA cable connector 1 |
| 9. SATA cable connector 2 | 10. Hard-drive power cable connector (SATA PWR) |
| 11. PCIe x1 expansion slot (SLOT1) | 12. Coin-cell battery |
| 13. Processor | |

The following images indicate the location of the system board and provide a visual representation of the installation procedure.

1

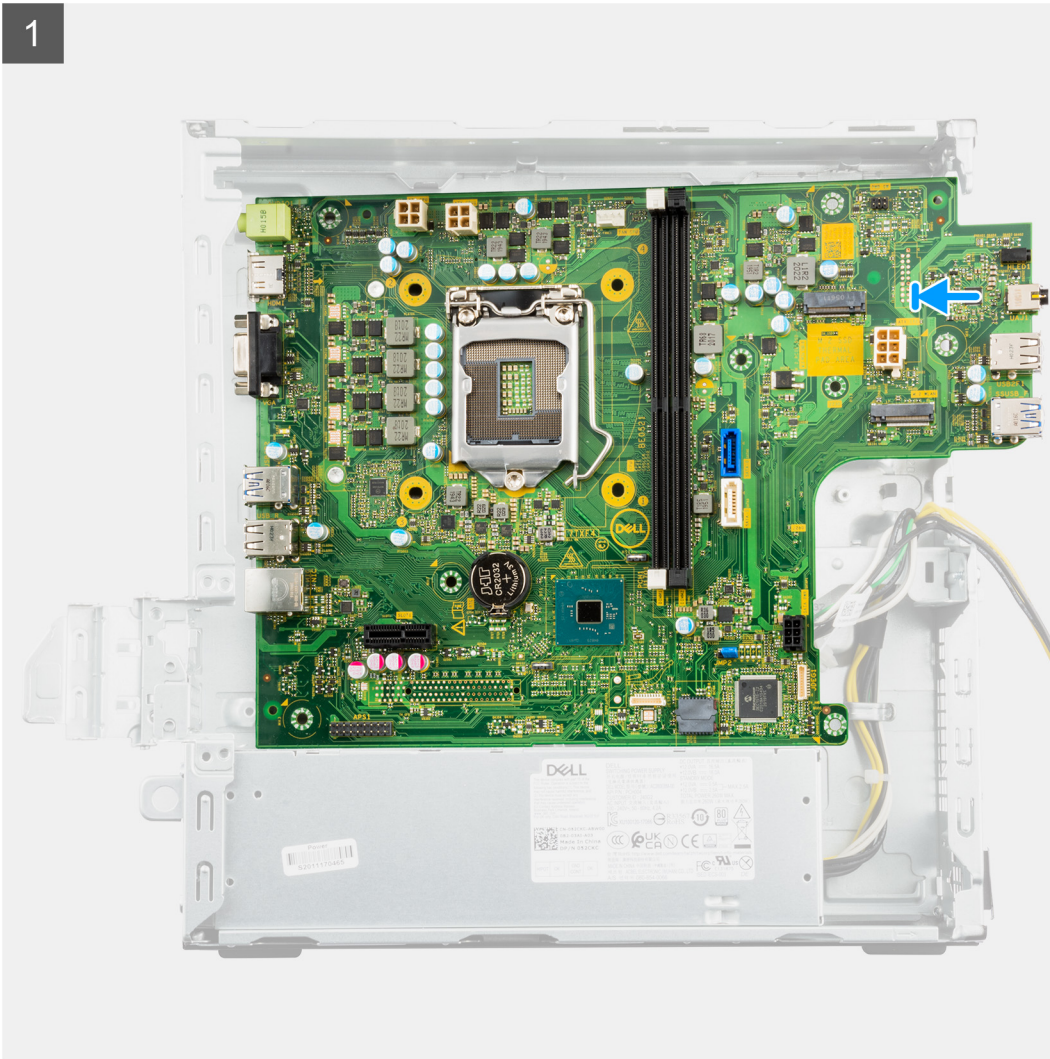

2

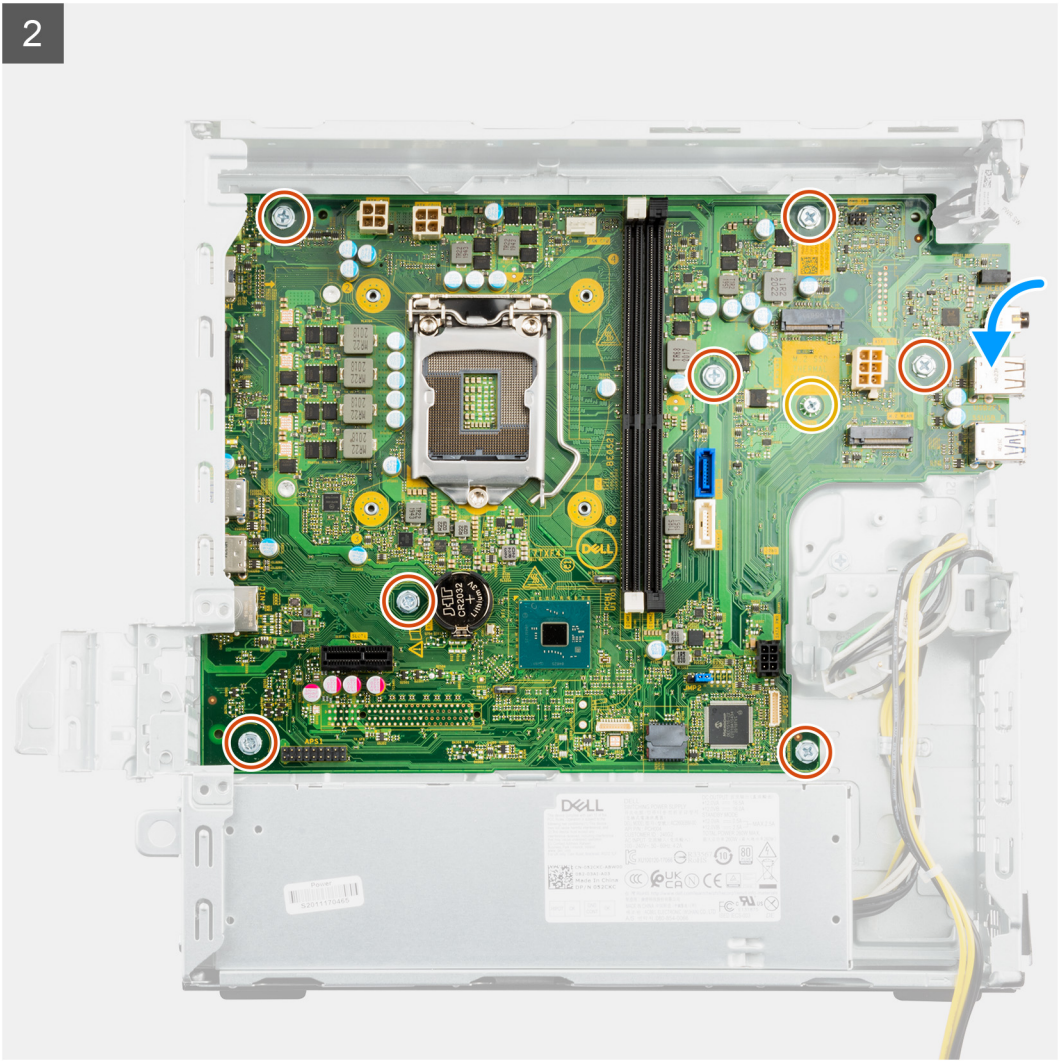



8x
6-32



1x
M2x4

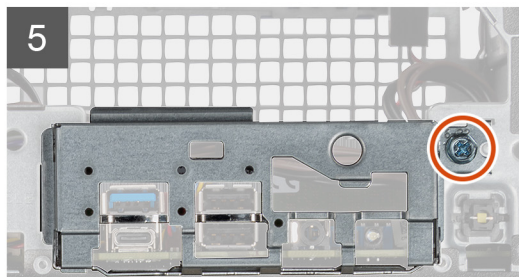
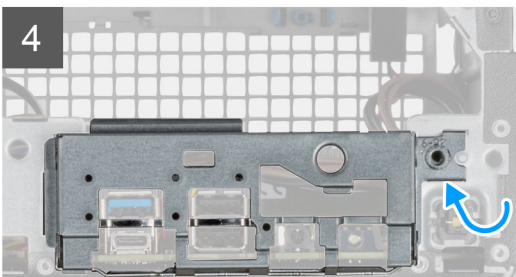

Steps



1. Slide and insert the system board at an angle into the chassis.
2. Slide the front I/O-ports on the system board into the front I/O-slots on the chassis.
3. Lower the system board onto the chassis, and align the screw holes on the system board with the chassis.
4. Replace the seven (#6-32) screws and one (M2x4) screw that secures the system board to the chassis.

 **NOTE:** Replace the single (M2x3.5) screw that secures the M.2 2230 solid-state drive to the system board (if not replaced earlier).

5. Using the routing points on the chassis, route and reconnect the following cables to the connectors on the system board:
 - Power-supply cables
 - Hard-drive cables
 - Power-button cable
6. Replace the single screw (#6-32) to secure the front I/O-bracket to the chassis.

Next steps

1. Install the [Processor](#).
 2. Install the [fan and heat-sink](#).

 **NOTE:** If either the processor or the fan and heat-sink assembly is replaced, use the thermal grease provided in the kit to ensure that thermal conductivity is achieved.
 3. Install the [power button](#).
 4. Install the [wireless card](#).
 5. Install the [solid-state drive](#).
 6. Install the [memory module](#).
 7. Install the [hard-drive bracket](#).
 8. Install the [2.5-inch hard drive](#) or [3.5-inch hard drive](#), whichever applicable.
 9. Install the [front cover](#).
 10. Install the [side cover](#).
 11. Follow the procedure in [after working inside your computer](#).
-  **NOTE:** Your computer's Service Tag is stored in the system board. You must enter the Service Tag in the BIOS setup program after you replace the system board.
-  **NOTE:** Replacing the system board removes any changes that you have made to the BIOS using the BIOS setup program. You must make the appropriate changes again after you replace the system board.

Drivers and downloads

Drivers and downloads

When troubleshooting, downloading or installing drivers it is recommended that you read the Dell Knowledge Based article, Drivers and Downloads FAQ [SLN128938](#).

System setup

Boot Sequence

Boot Sequence allows you to bypass the System Setup–defined boot device order and boot directly to a specific device (for example: optical drive or hard drive). During the Power-on Self Test (POST), when the Dell logo appears, you can:

- Access System Setup by pressing F2 key
- Bring up the one-time boot menu by pressing F12 key

The one-time boot menu displays the devices that you can boot from including the diagnostic option. The boot menu options are:

- Removable Drive (if available)
- STXXXX Drive (if available)
 - **NOTE:** XXX denotes the SATA drive number.
- Optical Drive (if available)
- SATA Hard Drive (if available)
- Diagnostics

The boot sequence screen also displays the option to access the System Setup screen.

System setup options

NOTE: Depending on this computer and its installed devices, the items listed in this section may or may not appear.

Table 3. System setup options—System information menu

| General-System Information | |
|----------------------------|--|
| System Information | |
| BIOS Version | Displays the BIOS version number. |
| Service Tag | Displays the Service Tag of the computer. |
| Asset Tag | Displays the Asset Tag of the computer. |
| Ownership Tag | Displays the ownership tag of the computer. |
| Manufacture Date | Displays the manufacture date of the computer. |
| Ownership Date | Displays the ownership date of the computer. |
| Express Service Code | Displays the express service code of the computer. |
| Memory Information | |
| Memory Installed | Displays the total computer memory installed. |
| Memory Available | Displays the total computer memory available. |
| Memory Speed | Displays the memory speed. |
| Memory Channel Mode | Displays single or dual channel mode. |
| Memory Technology | Displays the technology used for the memory. |
| DIMM 1 Size | Displays the DIMM 1 memory size. |
| DIMM 2 Size | Displays the DIMM 2 memory size. |

Table 3. System setup options—System information menu

| General-System Information | |
|-----------------------------------|---|
| PCI Information | |
| SLOT2 | Displays the PCI information of the computer. |
| SLOT3 | Displays the PCI information of the computer. |
| SLOT5_M.2 | Displays the PCI information of the computer. |
| Processor Information | |
| Processor Type | Displays the processor type. |
| Core Count | Displays the number of cores on the processor. |
| Processor ID | Displays the processor identification code. |
| Current Clock Speed | Displays the current processor clock speed. |
| Minimum Clock Speed | Displays the minimum processor clock speed. |
| Maximum Clock Speed | Displays the maximum processor clock speed. |
| Processor L2 Cache | Displays the Processor L2 Cache size. |
| Processor L3 Cache | Displays the Processor L2 Cache size. |
| HT Capable | Displays whether the processor is HyperThreading (HT) capable. |
| 64-Bit Technology | Displays whether 64-bit technology is used. |
| Device Information | |
| SATA-0 | Displays the SATA device information of the computer. |
| SATA-1 | Displays the SATA device information of the computer. |
| M.2 PCIe SSD-2 | Displays the M.2 PCIe SSD information of the computer. |
| LOM MAC Address | Displays the LOM MAC address of the computer. |
| Video Controller | Displays the video controller type of the computer. |
| Audio Controller | Displays the audio controller information of the computer. |
| Wi-Fi Device | Displays the wireless device information of the computer. |
| Bluetooth Device | Displays the Bluetooth device information of the computer. |
| Boot Sequence | |
| Boot Sequence | Displays the boot sequence. |
| Boot List Option | Displays the available boot options. |
| UEFI Boot Path Security | |
| Always,Except Internal HDD | Enable or disable the system to prompt the user to enter the Admin password when booting a UEFI boot path from the F12 boot menu. Default: Enabled |
| Always | Enable or disable the system to prompt the user to enter the Admin password when booting a UEFI boot path from the F12 boot menu. Default: Disabled |
| Never | Enable or disable the system to prompt the user to enter the Admin password when booting a UEFI boot path from the F12 boot menu. Default: Disabled |
| Date/Time | Displays the current date in MM/DD/YY format and current time in HH:MM:SS AM/PM format. |

Table 4. System setup options—System Configuration menu

| System Configuration | |
|-----------------------------|---------------------------------------|
| Integrated NIC | |
| Enable UEFI Network Stack | Controls the on-board LAN controller. |
| | Enable or disable UEFI Network Stack. |

Table 4. System setup options—System Configuration menu

| System Configuration | |
|--------------------------------|--|
| SATA Operation | Configure operating mode of the integrated SATA hard drive controller. |
| Drives | Enable or disable various drives on board. |
| SATA-0 | Displays the SATA device information of the computer. |
| SATA-1 | Displays the SATA device information of the computer. |
| M.2 PCIe SSD-2 | Displays the M.2 PCIe SSD information of the computer. |
| SMART Reporting | Enable or disable SMART Reporting during system startup. |
| USB Configuration | |
| Enable USB Boot Support | Enable or disable booting from USB mass storage devices such as external hard drive, optical drive, and USB drive. |
| Enable front USB Port | Enable or disable the front USB ports. |
| Enable rear USB Port | Enable or disable the rear USB ports. |
| Front USB Configuration | Enable or disable the front USB ports. |
| Rear USB Configuration | Enable or disable the rear USB ports. |
| Audio | Enable or disable the integrated audio controller. |
| Miscellaneous Devices | Enable or disable various onboard devices. |

Table 5. System setup options—Video menu

| Video | |
|-----------------|--------------------------------------|
| Multi-Display | Enable or disable multiple displays. |
| Primary Display | Set or change the primary display. |

Table 6. System setup options—Security menu

| Security | |
|-------------------------------|--|
| Admin Password | Set, change, or delete the administrator password. |
| System Password | Set, change, or delete the system password. |
| Internal HDD-0 Password | Set, change, or delete the internal hard-disk drive password. |
| Password Configuration | Control the minimum and maximum number of characters allowed for Admin and System passwords. |
| Password Change | Enable or disable changes to the System and Hard Disk passwords when an administrator password is set. |
| UEFI Capsule Firmware Updates | Enable or disable BIOS updates through UEFI capsule update packages. |
| PTT Security | |
| PTT On | Enable or disable Platform Trust Technology (PTT) visibility to the operating system. |
| Clear | Default: Disabled |
| PPI ByPass for Clear Command | Enable or disable the TPM Physical Presence Interface (PPI). When enabled, this setting will allow the OS to skip BIOS PPI user prompts when issuing the Clear command. Changes to this setting take effect immediately. Default: Disabled |
| Absolute(R) | Enable or disable the BIOS module interface of the optional Computrace(R) Service from Absolute Software. |
| Admin Setup Lockout | Enable to prevent users from entering Setup when an Admin Password is set. |
| Master Password Lockout | Disables the master password support. Hard Disk passwords need to be cleared before changing the setting. |

Table 6. System setup options—Security menu

| Security | |
|-------------------------|---|
| SMM Security Mitigation | Enable or disable SMM Security Mitigation |

Table 7. System setup options—Secure Boot menu

| Secure Boot | |
|------------------------------|---|
| Secure Boot Enable | Enable or disable the secure boot feature. |
| Secure Boot Mode | Modifies the behavior of Secure Boot to allow evaluation or enforcement of UEFI driver signatures. <ul style="list-style-type: none"> • Deployed Mode-Default: Enabled • Audit Mode-Default: Disabled |
| Deployed Mode | Enable or disable the deployed mode. |
| Audit Mode | Enable or disable the audit mode. |
| Expert Key Management | |
| Expert Key Management | Enable or disable Expert Key Management. |
| Custom Mode Key Management | Select the custom values for expert key management. |

Table 8. System setup options—Intel Software Guard Extensions menu

| Intel Software Guard Extensions | |
|--|--|
| Intel SGX Enable | Enable or disable Intel Software Guard Extensions. |
| Enclave Memory Size | Set the Intel Software Guard Extensions Enclave Reserve Memory Size. |
| Performance | |
| Multi Core Support | Enable multiple cores. Default: Enabled. |
| Intel SpeedStep | Enable or disable Intel Speedstep Technology. Default: Enabled. i NOTE: If enabled, the processor clock speed and core voltage are adjusted dynamically based on the processor load. |
| C-States Control | Enable or disable additional processor sleep states. Default: Enabled. |
| Intel TurboBoost | Enable or disable Intel TurboBoost mode of the processor. Default: Enabled. |
| HyperThread control | Enable or disable HyperThreading in the processor. Default: Enabled. |
| Power Management | |
| AC Recovery | Sets what action the computer takes when power is restored. |
| Enable Intel Speed Shift Technology | Enable or disable Intel Speed Shift Technology. |
| Auto On Time | Enable to set the computer to turn on automatically every day or on a preselected date and time. This option can be configured only if the Auto On Time is set to Everyday, Weekdays or Selected Days. Default: Disabled. |
| USB Wake Support | Enable the USB devices to wake the computer from Standby. |
| Deep Sleep Control | Enables you to control the Deep Sleep mode support. |

Table 8. System setup options—Intel Software Guard Extensions menu

| Intel Software Guard Extensions | |
|--|--|
| Wake on LAN/WLAN | Enables the computer to be powered on by special LAN signals. |
| Block sleep | Enables you to block entering to sleep mode in OS environment. |
| POST Behavior | |
| Numlock LED | Enables the NumLock function when computer boots. |
| Keyboard Errors | Enables the keyboard error detection. |
| Fastboot | Enable to set the speed of the boot process. Default: Thorough. |
| Extend BIOS POST Time | Configure additional pre-boot delay. |
| Full Screen Logo | Enable or disable to display full screen logo. |
| Warnings and Errors | Sets the boot process to pause when Warnings or Errors are detected. |

Table 9. System setup options—Virtualization Support menu

| Virtualization Support | |
|-------------------------------|--|
| Virtualization | Specify whether a Virtual Machine Monitor (VMM) can utilize the additional hardware capabilities provided by Intel Virtualization Technology. |
| VT for Direct I/O | Specify whether a Virtual Machine Monitor (VMM) can utilize the additional hardware capabilities provided by Intel Virtualization Technology for Direct I/O. |

Table 10. System setup options—Wireless menu

| Wireless | |
|------------------------|--|
| Wireless Device Enable | Enable or disable internal wireless devices. |

Table 11. System setup options—Maintenance menu

| Maintenance | |
|--------------------|---|
| Service Tag | Display the system's Service Tag. |
| Asset Tag | Create a system Asset Tag. |
| SERR Messages | Enable or disable SERR messages. |
| BIOS Downgrade | Control flashing of the system firmware to previous revisions. |
| Data Wipe | Enable to securely erase data from all internal storage devices. |
| BIOS Recovery | Enable the user to recover from certain corrupted BIOS conditions from a recovery file on the user primary hard drive or an external USB key. |

Table 12. System setup options—System Logs menu

| System Logs | |
|--------------------|----------------------|
| BIOS Events | Display BIOS events. |

Table 13. System setup options—SupportAssist System Resolution menu

| SupportAssist System Resolution | |
|--|--|
| Auto OS Recovery Threshold | Control the automatic boot flow for SupportAssist System Resolution Console and for Dell OS Recovery tool. |

Overview

This section provides hardware specification for the system and contains no modifiable settings.

Table 14. BIOS Overview Page (continued)

| Options | Description |
|--------------------------------|--|
| Series and system model number | <p>This field shows the following information:</p> <ul style="list-style-type: none"> ● BIOS Version - The version of the BIOS installed on the computer. ● Service tag - The unique 7 digit hexadecimal identification number for the computer. ● Asset tag ● Manufacture Date - The date for when the unit was manufactured. ● Ownership Date - The date for when the unit's ownership was transferred to the end user. ● Express Service Code - An alternative to Service Tag, 11-digit numerical identification number for the computer. ● Ownership Tag ● Signed Firmware Update - This helps to verify that only Dell Signed and released BIOS can be installed on the computer. |
| Processor | <p>The Processor field provides information related to the CPU on the computer:</p> <ul style="list-style-type: none"> ● Processor Type - This field mentions the CPU model and generation information. ● Maximum Clock Speed - This field mentions the maximum clock speed that the CPU is capable of reaching. ● Minimum Clock Speed - This field mentions the minimum clock speed that the CPU is capable of reaching. ● Current Clock Speed - This field mentions the clock speed that the CPU is running at currently. ● Core Count - This field gives the count of the physical cores on the CPU. ● Processor ID ● Processor L3 Cache - This field shows the amount of cache storage available on the CPU. ● Microcode Version ● Intel Hyper-Threading Capable - This field helps identify if the CPU is capable of Hyper-Threading. ● 64-bit Technology - This field helps identify the CPU architecture. |
| Memory | <p>The Memory field provides information related to the memory on the computer:</p> <ul style="list-style-type: none"> ● Memory Installed - This field gives the amount of memory installed on the computer. ● Memory Available - This field gives the amount of memory available for use on the computer. ● Memory Speed - This field mentions the speed at which the memory runs on the computer. ● Memory Channel Mode - This field helps us identify if the computer has Dual-Channel memory utilization capability. ● DIMM_SLOT 1 - This field shows the capacity of the memory installed in the first DIMM slot. ● DIMM_SLOT 2 - This field shows the capacity of the memory installed in the second DIMM slot. |
| Devices | <p>The Devices field provides information related to the memory on the computer:</p> |

Table 14. BIOS Overview Page

| Options | Description |
|---------|---|
| | <ul style="list-style-type: none"> ● Panel Type - This field mentions the type of display panel used on the computer. ● Video controller - This field mentions the type of video controller used on the computer. ● Video Memory - This field gives the capacity of the video memory available for use on the computer. ● Wi-Fi Device - This field mentions the type of wireless device available for use on the computer. ● Native Resolution - This field mentions the native video resolution supported on the computer. ● Video BIOS Version - The version of the BIOS installed on the computer. ● Audio Controller - This field mentions the type of audio controller used on the computer. ● Bluetooth Device - This field mentions the type of Bluetooth device available for use on the computer. ● LOM MAC Address - This field provides the unique MAC address for the computer. |

Boot Configuration

This section provides Boot Configuration related details and settings.

Table 15. Boot Configuration:

| Options | Description |
|------------------------------|--|
| Boot Sequence | |
| Boot Mode: UEFI only | <p>This section allows the user to choose the first bootable device that the computer should use to boot the system. It lists all potential bootable devices.</p> <ul style="list-style-type: none"> ● Windows Boot Manager (Enabled by default) ● UEFI Boot Drive (Enabled by default) ● Add Boot option - Allows the user to manually add a Boot path. |
| Secure Digital(SD) Card Boot | <p>This section contains a toggle switch that allows the user to enable or disable the option to allow the computer to boot from an SD Card.</p> |
| Secure Boot | |
| Enable Secure Boot | <p>This section contains a toggle switch that allows the user to enable or disable Secure Boot. (OFF by default)</p> |
| Secure Boot Mode | <p>This section allows the user to select one of the two Secure Boot options available on the computer:</p> <ul style="list-style-type: none"> ● Deployed Mode - This mode checks the integrity of UEFI drivers and bootloaders before allowing execution. This option allows for full Secure Boot protections (Enabled by default.) ● Audit Mode - This mode performs a signature check but never does a block execution of all UEFI drivers and bootloaders. This mode is only used when making changes to Secure Boot Keys. |
| Expert Key Management | |

Table 15. Boot Configuration:

| Options | Description |
|----------------------------|--|
| Enable Custom Mode | This section contains a toggle switch that allows the user to enable or disable Custom Mode. This mode allows the PK, KEK, db and dbx security key databases to be manipulated. (OFF by default) |
| Custom Mode Key Management | This section helps the user to select the Key Database to allow modification. The options available are as below: <ul style="list-style-type: none"> ● PK (Selected by default) ● KEK ● db ● dbx |

Integrated Devices

This section provides Integrated Devices details and settings.

Table 16. Integrated Devices (continued)

| Options | Description |
|-------------------------|---|
| Date/Time | |
| Date | This section allows the user to change the date which takes effect immediately. The format used is MM/DD/YYYY |
| Time | This section allows the user to change the time which takes effect immediately. The format used is HH/MM/SS in 24 hour format. The user also has an option to switch between 12-hours or 24-hours clock. |
| Audio | |
| Enable Audio | This section contains a toggle switch that allows the user to enable or disable the audio on the computer. It also allows the user to: <ul style="list-style-type: none"> ● Enable Microphone (Enabled by default.) |
| USB Configuration | This section helps the user to make changes to the USB settings on the computer. The options available are as follows(All options are enabled by default): <ul style="list-style-type: none"> ● Enable Front USB Ports ● Enable Rear USB Ports ● Enable USB Boot Support |
| Front USB Configuration | This section allows the user to manually enable the 4 USB ports on the front bezel (All USB ports are enabled by default.). The options are: <ul style="list-style-type: none"> ● Front Port 1 (Bottom Left) ● Front Port 2 (Bottom Right) ● Front Port 3 (Top Left) ● Front Port 4 (Top Right) |
| Rear USB Configuration | This section allows the user to manually enable the 4 USB ports on the back (All USB ports are enabled by default.). The options are: <ul style="list-style-type: none"> ● Rear Port 1 (Bottom Left) ● Rear Port 2 (Bottom Right) |

Table 16. Integrated Devices

| Options | Description |
|---------|--|
| | <ul style="list-style-type: none">• Rear Port 3 (Top Left)• Rear Port 4 (Top Right) |

Storage

This section provides storage details and settings.

Table 17. Storage

| Options | Description |
|------------------------|--|
| SATA Operation | |
| SATA Operation | This section allows the user to select the operating mode of the integrated SATA hard drive controller. The following options are available: <ul style="list-style-type: none">• Disabled - SATA controllers are disabled.• AHCI - SATA is configured in AHCI mode.• RAID On - SATA is setup to support RAID (Intel Rapid Storage Technology). (Selected by default) |
| Storage Interface | |
| Port Enablement | This section allows the user to enable or disable the onboard drives on the computer. The following options is available (ON by default). <ul style="list-style-type: none">• SATA-0• SATA-1• SATA-3• M.2 PCIe SSD-0 |
| SMART Reporting | |
| Enable SMART Reporting | This section contains a toggle switch that allows the user to enable or disable the S.M.A.R.T (Self-Monitoring, Analysis, and Reporting Technology) option on the system (OFF by default). |
| Drive Information | This section provides information about the connected and active drives on the computer. The following options are available: <ul style="list-style-type: none">• M.2 PCIe SSD-0<ul style="list-style-type: none">○ Type○ Device |

Display

This section provides display details and settings.

Table 18. Display

| Options | Description |
|-----------------|-------------|
| Primary Display | |

Table 18. Display

| Options | Description |
|-----------------------|---|
| Video Primary Display | This section allows the user to select the video controller for the primary display when multiple vide controllers are detected. The options are: <ul style="list-style-type: none"> • Auto (Selected by default) • Onboard Video |
| Full Screen Logo | |
| Full Screen Logo | This section contains a toggle switch which allows the user to enable/disable the option to view a full screen logo (disabled by default). |

Connection

This section provides connection details and settings.

Table 19. Connection

| Options | Description |
|----------------------------------|--|
| Network Controller Configuration | |
| Integrated NIC | This section allows the user to change the on-board LAN controller options. The options are as follows: <ul style="list-style-type: none"> • Disabled - The internal LAN is off and not visible to the operating system. • Enabled - The internal LAN is enabled. • Enabled with PXE (Selected by default) - The internal LAN is enabled with PXE boot capabilities. |
| Wireless Device Enable | This section contains a toggle switch that allows the user to enable or disable WLAN and Bluetooth on the computer. The options are as follows: <ul style="list-style-type: none"> • WLAN (Enabled by default). • Bluetooth (Enabled by default). |
| Enable UEFI Network Stack | This section contains a toggle switch that allows the user to enable or disable installation of UEFI networking protocols. (ON by default) |
| Wireless Radio Control | This section contains a toggle switch that allows the user to enable or disable a feature where the system will sense a connection to a wired network and disable the WLAN or WWAN connection (OFF by default). |
| HTTP(s) Boot Feature | |
| HTTP(s) Boot Feature | This section contains a toggle switch that allows the user to enable or disable HTTP(s) Boot capabilities (ON by default). |
| HTTP(s) Boot Modes | <ul style="list-style-type: none"> • Auto Mode - HTTP(s) Boot automatically extracts Boot URL from DHCP(Dynamic Host Configuration Protocol) - Selected by default. • Manual Mode - HTTP(s) Boot reads Boot URL provided by the user. <p>This section also contains an "Upload" and "Delete" option for provisioning of the certificates required to connect to HTTPs Boot server.</p> |

Power

This section provides power details and settings.

Table 20. Power

| Options | Description |
|--------------------------------------|--|
| USB Wake Support | |
| Enable USB Wake Support | <p>This section contains a toggle switch to allow the user to enable or disable USB Wake Support. It allows the system to use USB devices like a mouse and keyboard to wake the system from standby mode (OFF by default).</p> <p> NOTE: This feature only works if the power adapter is connected to the system.</p> |
| AC Behavior | <p>This section allows the user to control the behavior of the system when power is restored after an unexpected loss of power. The options here are:</p> <ul style="list-style-type: none"> • Power Off - System stays off after AC power is restored (Selected by default) • Power On - System powers on after AC power is restored • Last Power State - System returns to the previous state after AC power recovery |
| Active State Power Management (ASPM) | <p>This section allows the user to set the ASPM level. The options here are:</p> <ul style="list-style-type: none"> • Auto - There is handshaking between the device and PCI Express hub (Selected by default) • Disabled - ASPM power management is turned off at all times • L1 Only - ASPM power management is set to level 1 |
| Block Sleep | <p>This section determines how aggressively the system is conserving power while in Shutdown (S5) or Hiernate (S4) mode. The options are:</p> <ul style="list-style-type: none"> • Disabled • Enabled in S5 only • Enabled in S4 and S5 (Selected by default) |
| Intel Speed Shift Technology | |
| Intel Speed Shift Technology | <p>This section contains a toggle switch to allow the user to enable or disable Intel Speed Shift Technology support. This feature enables the operating system to select appropriate processor performance automatically (ON by default).</p> |

Security

This section provides security details and settings.

Table 21. Security

| Options | Description |
|---------------------------------------|--|
| Intel Platform Trust Technology (PTT) | <p>This section contains a toggle switch to select whether Intel PTT is visible to the Operating System(OS). (ON by default)</p> |

Table 21. Security

| Options | Description |
|-------------------------------|---|
| PPI Bypass for Clear Commands | This section contains a toggle switch which controls the TPM Physical Presence Interface(PPI). When enabled, this setting will allow the OS to skip BIOS PPI user prompts when issuing the clear command (OFF by default). |
| Clear | This section contains a toggle switch which clears the TPM owner information, and returns the TPM to the default state (OFF by default). |
| SMM Security Mitigation | This section allows the user to enable or disable UEFI SMM security Mitigation protections (ON by default). |
| Data Wipe on Next Boot | |
| Start Data Wipe | This section contains toggle switch which when enabled ensures that the BIOS will queue up a data wipe cycle for storage device(s) connected to the system board on the next reboot (OFF by default). |
| Absolute | |
| Absolute | This section lets the user enable, disable or permanently disable the BIOS module interface of the optional Absolute Persistence Module service from Absolute Software. The options available are as follows: <ul style="list-style-type: none"> • Enable Absolute - Enables Absolute Persistence and load the firmware Persistence Module (Selected by default) • Disable Absolute - Disables Absolute Persistence. The firmware Persistence Module is not installed. • Permanently Disable Absolute - Permanently disables Absolute Persistence module interface from further use. |
| UEFI Boot Path Security | |
| UEFI Boot Path Security | This section lets the user control whether the system will prompt the user to enter the admin password(if set) when booting to a UEFI booth path device from F12 boot menu. The options available are as below: <ul style="list-style-type: none"> • Never • Always • Always Except Internal HDD (Selected by default) • Always Except Internal HDD&PXE |

Passwords

This section provides details on password settings.

Table 22. Passwords

| Options | Description |
|-----------------------|--|
| Admin Password | This field allows the user to set, change, or delete the administrator password. |
| System Password | This field allows the user to set, change, or delete the system password. |
| Password Configurator | |

Table 22. Passwords

| Options | Description |
|-----------------------------------|---|
| Upper Case Letter | Enable or disable reinforced use of upper case letters (OFF by default). |
| Lower Case Letter | Enable or disable reinforced use of lower case letters (OFF by default). |
| Digit | Enable or disable reinforced use of at least one digit (OFF by default). |
| Special Character | Enable or disable reinforced use of at least one special character (OFF by default). |
| Minimum Character | Allows the user to select the number of characters allowed for a password (4 is the default value). |
| Password Changes | |
| Enable Non-Admin Password Changes | This section contains a toggle switch which when on, user can change system and hard drive password without the need for admin password (OFF by default). |
| Admin Setup Lockout | |
| Enable Admin Setup Lockout | This section contains a toggle switch which allows the administrator to control how users can or cannot access BIOS setup (OFF by default). |
| Active Password Lockout | |
| Enable Active Password Lockout | This section contains a toggle switch which allows the user to disable active password support (OFF by default). |

Update Recovery

This section provides details on Update Recovery settings.

Table 23. Update Recovery

| Options | Description |
|--------------------------------------|--|
| UEFI capsule Firmware Updates | |
| Enable UEFI Capsule Firmware Updates | This field contains a toggle switch which allows the user to enable or disable BIOS updates through UEFI capsule update packages (ON by default). |
| BIOS Recovery from Hard Drive | |
| BIOS Recovery from Hard Drive | This field contains a toggle switch which allows the user to enable or disable recovery from certain corrupted BIOS conditions from a recovery file on the user's primary hard drive or an external USB key (ON by default). |
| BIOS Downgrade | |
| Allow BIOS Downgrade | This field contains a toggle switch which allows the user to enable or disable flashing of the system firmware to previous revisions. |
| SupportAssist OS Recovery | |

Table 23. Update Recovery

| Options | Description |
|---------------------------------|--|
| SupportAssist OS Recovery | This field contains a toggle switch which allows the user to enable or disable the boot flow for SupportAssist OS Recovery tool in the events of certain system errors (ON by default). |
| BIOSConnect | |
| BIOSConnect | This field contains a toggle switch which allows the user to enable or disable BIOSConnect setup to attempt cloud Service OS recovery if the main operating system fails to boot with a set number of failures (ON by default). |
| Dell Auto OS Recovery Threshold | |
| Dell Auto OS Recovery Threshold | This field allows the user to select the number of failed boot attempts by the system before SupportAssist OS Recovery is triggered. The options here are as below: <ul style="list-style-type: none"> • Off • 1 • 2 (selected by default) • 3 |

System Management

This section provides System Management settings.

Table 24. System Management

| Options | Description |
|--------------|--|
| Service Tag | |
| Service Tag | This field provides the unique Service Tag of the computer. |
| Asset Tag | |
| Asset Tag | This field provides the asset tag which is a unique and up to 64-character identification that can be set by the IT administrator. |
| Wake on LAN | |
| Wake on LAN | This field allows the user to select if and how the system should boot when connected to LAN. The options here are as follows: <ul style="list-style-type: none"> • Disabled - The system will not boot with any special LAN signals (selected by default). • LAN only - Allows the system to be powered on by a special LAN signal from a network computer. • WLAN only - Allows the system to power on by special WLAN signals. • LAN or WLAN - Allows the system to power on by special LAN or wireless LAN signals. • LAN with PXE Boot - Allows the system to wake-up from S4 or S5 state and boot to PXE. |
| Auto On Time | |

Table 24. System Management

| Options | Description |
|---------------------|---|
| Auto On Time | This field allows the user to set defined days/time when the system can automatically power on. The options here are as follows: <ul style="list-style-type: none">• Disabled (selected by default)• Everyday• Weekdays• Select Days |
| SERR Messages | This section allows the user to enable or disable(ON/OFF) the SERR message mechanism (ON by default).  NOTE: Some graphics cards require SERR message mechanism to be disabled. |
| First Power On Date | This option if enabled lets the user see the ownership date (disabled by default). |

Keyboard

This section provides keyboard settings.

Table 25. Keyboard

| Options | Description |
|---------------------------------|--|
| Enable keyboard Error Detection | This field contains a toggle switch(ON/OFF) to allow the keyboard-related errors to be reported when the system boots. |
| Numlock LED | This field contains a toggle switch(ON/OFF) to allow the user to decide if the Numlock LED should be on when the system boots. |

Virtualization

This section provides details on Virtualization settings.

Table 26. Virtualization

| Options | Description |
|--|---|
| Intel Virtualization Technology | |
| Enable Intel Virtualization Technology(VT) | This field contains a toggle switch to enable or disable Virtualization to run Virtual machine monitor(VMM) (enabled by default). |
| VT for Direct I/O | |
| Enable Intel VT for Direct I/O | This field allows the user to enable or disable the system from being able to perform VT for Direct I/O (enabled by default). |

Performance

This section provides Performance settings.

Table 27. Performance

| Options | Description |
|---|--|
| Multi-Core Support | |
| Active Cores | This field allows the user to configure the number of active cores on the computer. The options are as follows: <ul style="list-style-type: none"> ● All Cores (selected by default) ● 1 ● 2 ● 3 |
| Intel SpeedStep | |
| Enable Intel SpeedStep Technology | This field contains a toggle switch to enable or disable Intel SpeedStep Technology which allows the computer to dynamically adjust processor voltage and core frequency, decreasing average power consumption and heat production (enabled by default). |
| C-States Control | |
| Enable C-States Control | This field contains a toggle switch to enable or disable C-States Control that configures the CPU's ability to enter and exit low power states. When off, it disables all C-States (enabled by default). |
| Intel Turbo Boost Technology | |
| Enable Intel Turbo Boost Technology | This field allows the user to enable or disable Intel Turbo Boost Technology (enabled by default). <ul style="list-style-type: none"> ● Disabled - Does not allow the Intel Turbo Boost Technology driver to increase the performance state of the processor above the standard performance. ● Enabled - Allows the Intel Turbo Boost Technology to increase the performance of the CPU or graphics processor. |
| Intel Hyper-Threading Technology | |
| Enable Intel Hyper-Threading Technology | This field allows the user to configure this feature where the processor resources are used more effectively, enabling multiple threads to run on each core (enabled by default). |
| Dynamic Tuning: Machine Learning | |
| Enable Dynamic Tuning: Machine Learning | This field allows the user to configure the OS' capability to enhance dynamic power tuning capabilities based on detected workloads (disabled by default) |

System Logs

This section contains BIOS, Thermal and Power event logs.

Table 28. System Logs

| Options | Description |
|----------------------|---|
| BIOS Event Log | |
| Clear BIOS Event log | This field contains a toggle switch to Keep or Clear BIOS Event logs. It also lists all saved events(Date, Time, Message) - ("Keep" selected by default). |

Flashing the BIOS

About this task

You may need to flash (update) the BIOS when an update is available or when you replace the system board.

Follow these steps to flash the BIOS:

Steps

1. Turn on your computer.
2. Go to www.dell.com/support.
3. Click **Product support**, enter the Service Tag of your computer, and then click **Submit**.

 **NOTE:** If you do not have the Service Tag, use the auto-detect feature or manually browse for your computer model.

4. Click **Drivers & downloads > Find it myself**.
5. Select the operating system installed on your computer.
6. Scroll down the page and expand **BIOS**.
7. Click **Download** to download the latest version of the BIOS for your computer.
8. After the download is complete, navigate to the folder where you saved the BIOS update file.
9. Double-click the BIOS update file icon and follow the instructions on the screen.

Flashing BIOS (USB key)

Steps

1. Follow the procedure from step 1 to step 7 in "Flashing the BIOS" to download the latest BIOS setup program file.
2. Create a bootable USB drive. For more information see the knowledge base article [SLN143196](https://www.dell.com/support/sln/143196) at www.dell.com/support.
3. Copy the BIOS setup program file to the bootable USB drive.
4. Connect the bootable USB drive to the computer that needs the BIOS update.
5. Restart the computer and press **F12** when the Dell logo is displayed on the screen.
6. Boot to the USB drive from the **One Time Boot Menu**.
7. Type the BIOS setup program filename and press **Enter**.
8. The **BIOS Update Utility** appears. Follow the instructions on the screen to complete the BIOS update.

Assigning a system setup password

Prerequisites

You can assign a new **System or Admin Password** only when the status is in **Not Set**.

About this task

To enter the system setup, press F12 immediately after a power-on or reboot.

Steps

1. In the **System BIOS** or **System Setup** screen, select **Security** and press Enter.
The **Security** screen is displayed.
2. Select **System/Admin Password** and create a password in the **Enter the new password** field.

Use the following guidelines to assign the system password:

- A password can have up to 32 characters.
- The password can contain the numbers 0 through 9.
- Only lower case letters are valid, upper case letters are not valid.
- Only the following special characters are valid: Space, ("), (+), (.), (-), (.), (/), (:), ([), (\), (]), (`).

3. Type the system password that you entered earlier in the **Confirm new password** field and click **OK**.
4. Press Esc and a message prompts you to save the changes.
5. Press Y to save the changes.
The computer restarts.

Deleting or changing an existing system setup password

Prerequisites

Ensure that the **Password Status** is Unlocked (in the System Setup) before attempting to delete or change the existing System and/or Setup password. You cannot delete or change an existing System or Setup password, if the **Password Status** is Locked.

About this task

To enter the System Setup, press F12 immediately after a power-on or reboot.

Steps

1. In the **System BIOS** or **System Setup** screen, select **System Security** and press Enter.
The **System Security** screen is displayed.
2. In the **System Security** screen, verify that **Password Status** is **Unlocked**.
3. Select **System Password**, update, or delete the existing system password, and press Enter or Tab.
4. Select **Setup Password**, update, or delete the existing setup password, and press Enter or Tab.
 **NOTE:** If you change the System and/or Setup password, reenter the new password when prompted. If you delete the System and/or Setup password, confirm the deletion when prompted.
5. Press Esc and a message prompts you to save the changes.
6. Press Y to save the changes and exit from System Setup.
The computer restarts.

Troubleshooting

Dell SupportAssist Pre-boot System Performance Check diagnostics

About this task

SupportAssist diagnostics (also known as system diagnostics) performs a complete check of your hardware. The Dell SupportAssist Pre-boot System Performance Check diagnostics is embedded with the BIOS and is launched by the BIOS internally. The embedded system diagnostics provides a set of options for particular devices or device groups allowing you to:

- Run tests automatically or in an interactive mode
- Repeat tests
- Display or save test results
- Run thorough tests to introduce additional test options to provide extra information about the failed device(s)
- View status messages that inform you if tests are completed successfully
- View error messages that inform you of problems encountered during testing

 **NOTE:** Some tests for specific devices require user interaction. Always ensure that you are present at the computer terminal when the diagnostic tests are performed.

For more information, see [Resolve Hardware Issues With Built-in and Online Diagnostics \(SupportAssist ePSA, ePSA or PSA Error Codes\)](#).

Running the SupportAssist Pre-Boot System Performance Check

Steps

1. Turn on your computer.
2. As the computer boots, press the F12 key as the Dell logo appears.
3. On the boot menu screen, select the **Diagnostics** option.
4. Click the arrow at the bottom left corner.
Diagnostics front page is displayed.
5. Click the arrow in the lower-right corner to go to the page listing.
The items detected are listed.
6. To run a diagnostic test on a specific device, press Esc and click **Yes** to stop the diagnostic test.
7. Select the device from the left pane and click **Run Tests**.
8. If there are any issues, error codes are displayed.
Note the error code and validation number and contact Dell.

Dell Enhanced Pre-Boot System Assessment — ePSA Diagnostic 3.0

You can invoke the ePSA diagnostics by either of the following ways :

- Press the F12 key when the system posts and choose **ePSA or Diagnostics** option on One Time Boot Menu.
- Press and hold Fn(Function key on keyboard) and **Power On** (PWR) the system.

For more details, see [Dell EPSA Diagnostic 3.0](#).

System diagnostic lights

Power-supply diagnostics light

Indicates the status of the power-supply in either of the two states:

- Off: No Power
- On: Power is supplied.

Power button light

Table 29. Power button LED status

| Power button LED state | System state | Description |
|------------------------|--|-------------------------------------|
| Off | <ul style="list-style-type: none"> • S4 • S5 | There is in Hibernate or Off state. |
| Solid White | S0 | Working state |
| Solid Amber | | Various sleep states or No POST |
| Blinking Amber/White | | Failure to POST |

This platform relies on the Power button LED light blinking in an amber/white pattern to determine a failure as listed in the following table:

NOTE:

The blinking patterns consists of two numbers (representing First Group: Amber blinks, Second Group: White blinks).

- **First Group:** The Power button LED light blinks Amber, 1 to 9 times followed by a short pause with LED off for a couple of seconds.
- **Second Group:** The Power button LED light then blinks White, 1 to 9 times, followed by a longer pause before the next cycle starts again after a short interval.

Example: No Memory detected (2,3). Power button LED blinks 2-times in Amber followed by a pause, and then blinks 3-times in White. The Power button LED will pause for few seconds before the next cycle repeats itself again.

Table 30. Diagnostic LED status

| Blinking pattern | | Problem description | Suggested resolution |
|------------------|-------|---|--|
| Amber | White | | |
| 1 | 2 | Unrecoverable SPI flash failure | |
| 2 | 1 | CPU failure | <ul style="list-style-type: none"> • Run the Intel CPU diagnostics tools. • If problem persists, replace the system board. |
| 2 | 2 | System board failure (including BIOS corruption or ROM error) | <ul style="list-style-type: none"> • Flash latest BIOS version. • If problem persists, replace the system board. |
| 2 | 3 | No memory/RAM detected | <ul style="list-style-type: none"> • Confirm that the memory module is installed properly. • If problem persists, replace the memory module. |
| 2 | 4 | Memory/RAM failure | <ul style="list-style-type: none"> • Reset the memory module. • If problem persists, replace the memory module. |

Table 30. Diagnostic LED status

| Blinking pattern | | Problem description | Suggested resolution |
|------------------|---|--|---|
| 2 | 5 | Invalid Memory installed | <ul style="list-style-type: none"> Reset the memory module. If problem persists, replace the memory module. |
| 2 | 6 | System board error, chipset error, clock failure, gate A20 failure, super I/O failure, keyboard controller failure | <ul style="list-style-type: none"> Flash latest BIOS version. If problem persists, replace the system board. |
| 3 | 1 | CMOS battery failure | <ul style="list-style-type: none"> Reset the CMOS battery connection. If problem persists, replace the RTS battery. |
| 3 | 2 | PCIe or video card/chip failure | <ul style="list-style-type: none"> Replace the system board. |
| 3 | 3 | BIOS recovery image not found | <ul style="list-style-type: none"> Flash latest BIOS version. If problem persists, replace the system board. |
| 3 | 4 | BIOS recovery image found but invalid | <ul style="list-style-type: none"> Flash latest BIOS version. If problem persists, replace the system board. |
| 3 | 5 | Power Rail Failure | <ul style="list-style-type: none"> EC ran into power sequencing failure. If problem persists, replace the system board. |
| 3 | 6 | Paired SPI volume error | <ul style="list-style-type: none"> Flash corruption detected by SBIOS. If problem persists, replace the system board. |
| 3 | 7 | Intel ME (Management Engine) error | <ul style="list-style-type: none"> Timeout waiting on ME to reply to HECI message. If problem persists, replace the system board. |
| 4 | 2 | CPU power cable connection issue | |

Real-Time Clock (RTC Reset)

The Real Time Clock (RTC) reset function allows you or the service technician to recover Dell Inspiron, systems from No POST/No Power/No Boot situations. The legacy jumper enabled RTC reset has been retired on these models.

Start the RTC reset with the system powered off and connected to AC power. Press and hold the power button for thirty (30) seconds. The system RTC Reset occurs after you release the power button.

Flashing the BIOS

About this task

You may need to flash (update) the BIOS when an update is available or when you replace the system board.

Follow these steps to flash the BIOS:

Steps

1. Turn on your computer.
2. Go to www.dell.com/support.
3. Click **Product support**, enter the Service Tag of your computer, and then click **Submit**.

 **NOTE:** If you do not have the Service Tag, use the auto-detect feature or manually browse for your computer model.

4. Click **Drivers & downloads** > **Find it myself**.
5. Select the operating system installed on your computer.
6. Scroll down the page and expand **BIOS**.
7. Click **Download** to download the latest version of the BIOS for your computer.
8. After the download is complete, navigate to the folder where you saved the BIOS update file.
9. Double-click the BIOS update file icon and follow the instructions on the screen.

Flashing BIOS (USB key)

Steps

1. Follow the procedure from step 1 to step 7 in "Flashing the BIOS" to download the latest BIOS setup program file.
2. Create a bootable USB drive. For more information see the knowledge base article [SLN143196](https://www.dell.com/support/SLN143196) at www.dell.com/support.
3. Copy the BIOS setup program file to the bootable USB drive.
4. Connect the bootable USB drive to the computer that needs the BIOS update.
5. Restart the computer and press **F12** when the Dell logo is displayed on the screen.
6. Boot to the USB drive from the **One Time Boot Menu**.
7. Type the BIOS setup program filename and press **Enter**.
8. The **BIOS Update Utility** appears. Follow the instructions on the screen to complete the BIOS update.

WiFi power cycle

About this task

If your computer is unable to access the internet due to WiFi connectivity issues a WiFi power cycle procedure may be performed. The following procedure provides the instructions on how to conduct a WiFi power cycle:

 **NOTE:** Some ISPs (Internet Service Providers) provide a modem/router combo device.

Steps



1. Turn off your computer.
2. Turn off the modem.
3. Turn off the wireless router.
4. Wait for 30 seconds.
5. Turn on the wireless router.
6. Turn on the modem.
7. Turn on your computer.

Getting help and contacting Dell

Self-help resources

You can get information and help on Dell products and services using these self-help resources:

Table 31. Self-help resources

| Self-help resources | Resource location |
|---|--|
| Information about Dell products and services | www.dell.com |
| My Dell |  |
| Tips |  |
| Contact Support | In Windows search, type <code>Contact Support</code> , and press Enter. |
| Online help for operating system | www.dell.com/support/windows www.dell.com/support/linux |
| Access top solutions, diagnostics, drivers and downloads, and learn more about your computer through videos, manuals and documents. | Your Dell computer is uniquely identified by a Service Tag or Express Service Code. To view relevant support resources for your Dell computer, enter the Service Tag or Express Service Code at www.dell.com/support . For more information on how to find the Service Tag for your computer, see Locate the Service Tag on your computer . |
| Dell knowledge base articles for a variety of computer concerns | <ol style="list-style-type: none"> 1. Go to www.dell.com/support. 2. On the menu bar at the top of the Support page, select Support > Knowledge Base. 3. In the Search field on the Knowledge Base page, type the keyword, topic, or model number, and then click or tap the search icon to view the related articles. |

Contacting Dell

To contact Dell for sales, technical support, or customer service issues, see www.dell.com/contactdell.

 **NOTE:** Availability varies by country/region and product, and some services may not be available in your country/region.

 **NOTE:** If you do not have an active Internet connection, you can find contact information about your purchase invoice, packing slip, bill, or Dell product catalog.