

# Vostro 3582

Service Manual (without optical drive)



## Notes, cautions, and warnings

 **NOTE:** A NOTE indicates important information that helps you make better use of your product.

 **CAUTION:** A CAUTION indicates either potential damage to hardware or loss of data and tells you how to avoid the problem.

 **WARNING:** A WARNING indicates a potential for property damage, personal injury, or death.

© 2019 Dell Inc. or its subsidiaries. All rights reserved. Dell, EMC, and other trademarks are trademarks of Dell Inc. or its subsidiaries. Other trademarks may be trademarks of their respective owners.

<b>1 Working on your computer</b>	<b>6</b>
Safety instructions	6
Before working inside your computer	6
Electrostatic discharge—ESD protection	7
Transporting sensitive components	7
Lifting equipment	7
ESD field service kit	8
Components of an ESD field service kit	8
ESD protection summary	8
After working inside your computer	9
<b>2 Technology and components</b>	<b>10</b>
DDR4	10
DDR4 Details	10
Memory Errors	11
HDMI 1.4	11
HDMI 1.4 Features	11
Advantages of HDMI	12
USB features	12
USB 3.0/USB 3.1 Gen 1 (SuperSpeed USB)	12
Speed	13
Applications	13
Compatibility	14
Intel Optane memory	14
Enabling Intel Optane memory	14
Disabling Intel Optane memory	15
<b>3 Removing and installing components</b>	<b>16</b>
Recommended tools	16
Screw list	16
SD card	17
Removing the SD card	17
Installing the SD card	18
Base cover	18
Removing the base cover	18
Installing the base cover	20
Battery	21
Removing the battery	21
Installing the battery	22
Memory modules	23
Removing the memory module	23
Installing the memory module	24
M2. SATA Solid State Drive (SSD)	25

Removing the M.2 2280 solid state drive.....	25
Installing the M.2 2280 Solid state drive .....	26
Removing the M.2 2230 Solid state drive.....	27
Installing the M.2 2230 Solid state drive.....	28
I/O board.....	30
Removing the I/O board.....	30
Installing the IO board.....	31
Touchpad.....	33
Removing the touchpad.....	33
Installing the touchpad.....	35
Hard drive assembly.....	37
Removing the hard drive assembly.....	37
Installing the hard drive assembly.....	38
Hard drive.....	38
Removing the hard drive .....	38
Installing the hard drive .....	39
WLAN card.....	40
Removing the WLAN card.....	40
Installing the WLAN card.....	41
Coin-cell battery.....	42
Removing the coin-cell battery.....	42
Installing the coin-cell battery.....	43
Thermal plate.....	44
Removing the thermal plate.....	44
Installing the thermal plate.....	46
Speaker.....	47
Removing the speakers.....	47
Installing the speakers .....	48
Display assembly.....	49
Removing the display assembly.....	49
Installing the display assembly.....	51
System board.....	54
Removing the system board.....	54
Installing the system board.....	57
Display bezel.....	60
Removing the display bezel.....	60
Installing the display bezel .....	61
Camera.....	61
Removing the camera.....	61
Installing the camera.....	62
Display panel.....	63
Removing the display panel.....	63
Installation display panel.....	65
Display hinges.....	67
Removing the display hinges.....	67
Installing the display hinges.....	68
Display cable.....	69

Removing the display cable.....	69
Installing the display cable.....	70
Power button board.....	71
Removing the power button board.....	71
Installing the power button board.....	72
Power button.....	73
Removing the power button.....	73
Installing the power button .....	74
Power connector port.....	75
Removing the power connector port.....	75
Installing power connector port.....	76
Display back-cover.....	77
Removing the display back-cover.....	77
Palm-rest and keyboard assembly.....	78
Removing the palmrest and keyboard assembly.....	78
<b>4 Troubleshooting.....</b>	<b>80</b>
Enhanced Pre-Boot System Assessment (ePSA) diagnostics.....	80
Running the ePSA diagnostics.....	80
System diagnostic lights.....	80
Flashing BIOS (USB key).....	81
Flashing the BIOS.....	82
Backup media and recovery options.....	82
WiFi power cycle.....	82
Flea power release.....	82
<b>5 Getting help.....</b>	<b>83</b>
Contacting Dell.....	83

# Working on your computer

## Safety instructions

Use the following safety guidelines to protect your computer from potential damage and to ensure your personal safety. Unless otherwise noted, each procedure included in this document assumes that the following conditions exist:

- You have read the safety information that shipped with your computer.
- A component can be replaced or, if purchased separately, installed by performing the removal procedure in the reverse order.

**⚠ WARNING:** Disconnect all power sources before opening the computer cover or panels. After you finish working inside the computer, replace all covers, panels, and screws before connecting to the power source.

**⚠ WARNING:** Before working inside your computer, read the safety information that shipped with your computer. For additional safety best practices information, see the Regulatory Compliance Homepage at [www.dell.com/regulatory\\_compliance](http://www.dell.com/regulatory_compliance)

**⚠ CAUTION:** Many repairs may only be done by a certified service technician. You should only perform troubleshooting and simple repairs as authorized in your product documentation, or as directed by the online or telephone service and support team. Damage due to servicing that is not authorized by Dell is not covered by your warranty. Read and follow the safety instructions that came with the product.

**⚠ CAUTION:** To avoid electrostatic discharge, ground yourself by using a wrist grounding strap or by periodically touching an unpainted metal surface that is grounded to ground yourself before you touch the computer to perform any disassembly tasks.

**⚠ CAUTION:** Handle components and cards with care. Do not touch the components or contacts on a card. Hold a card by its edges or by its metal mounting bracket. Hold a component such as a processor by its edges, not by its pins.

**⚠ CAUTION:** When you disconnect a cable, pull on its connector or on its pull-tab, not on the cable itself. Some cables have connectors with locking tabs; if you are disconnecting this type of cable, press in on the locking tabs before you disconnect the cable. As you pull connectors apart, keep them evenly aligned to avoid bending any connector pins. Also, before you connect a cable, ensure that both connectors are correctly oriented and aligned.

**ⓘ NOTE:** The color of your computer and certain components may appear differently than shown in this document.

## Before working inside your computer

### About this task

To avoid damaging your computer, perform the following steps before you begin working inside the computer.

### Steps

- 1 Ensure that you follow the [Safety instructions](#).
- 2 Ensure that your work surface is flat and clean to prevent the computer cover from being scratched.
- 3 If the computer is connected to a docking device (docked), undock it.

**⚠ CAUTION:** To disconnect a network cable, first unplug the cable from your computer and then unplug the cable from the network device.

- 4 Disconnect all network cables from the computer.
- 5 Disconnect your computer and all attached devices from their electrical outlets.
- 6 Close the display and turn the computer upside-down on a flat work surface.

**ⓘ NOTE:** To avoid damaging the system board, you must remove the main battery before you service the computer.

- 7 Remove the main battery.

- 8 Turn the computer top-side up.
- 9 Open the display.
- 10 Press the power button to ground the system board.

**⚠ CAUTION: To guard against electrical shock, always unplug your computer from the electrical outlet before opening the display.**

**⚠ CAUTION: Before touching anything inside your computer, ground yourself by touching an unpainted metal surface, such as the metal at the back of the computer. While you work, periodically touch an unpainted metal surface to dissipate static electricity, which could harm internal components.**

- 11 Remove any installed ExpressCards or Smart Cards from the appropriate slots.

## Electrostatic discharge—ESD protection

ESD is a major concern when you handle electronic components, especially sensitive components such as expansion cards, processors, memory DIMMs, and system boards. Very slight charges can damage circuits in ways that may not be obvious, such as intermittent problems or a shortened product life span. As the industry pushes for lower power requirements and increased density, ESD protection is an increasing concern.

Due to the increased density of semiconductors used in recent Dell products, the sensitivity to static damage is now higher than in previous Dell products. For this reason, some previously approved methods of handling parts are no longer applicable.

Two recognized types of ESD damage are catastrophic and intermittent failures.

- **Catastrophic** – Catastrophic failures represent approximately 20 percent of ESD-related failures. The damage causes an immediate and complete loss of device functionality. An example of catastrophic failure is a memory DIMM that has received a static shock and immediately generates a "No POST/No Video" symptom with a beep code emitted for missing or nonfunctional memory.
- **Intermittent** – Intermittent failures represent approximately 80 percent of ESD-related failures. The high rate of intermittent failures means that most of the time when damage occurs, it is not immediately recognizable. The DIMM receives a static shock, but the tracing is merely weakened and does not immediately produce outward symptoms related to the damage. The weakened trace may take weeks or months to melt, and in the meantime may cause degradation of memory integrity, intermittent memory errors, etc.

The more difficult type of damage to recognize and troubleshoot is the intermittent (also called latent or "walking wounded") failure.

Perform the following steps to prevent ESD damage:

- Use a wired ESD wrist strap that is properly grounded. The use of wireless anti-static straps is no longer allowed; they do not provide adequate protection. Touching the chassis before handling parts does not ensure adequate ESD protection on parts with increased sensitivity to ESD damage.
- Handle all static-sensitive components in a static-safe area. If possible, use anti-static floor pads and workbench pads.
- When unpacking a static-sensitive component from its shipping carton, do not remove the component from the anti-static packing material until you are ready to install the component. Before unwrapping the anti-static packaging, ensure that you discharge static electricity from your body.
- Before transporting a static-sensitive component, place it in an anti-static container or packaging.

## Transporting sensitive components

When transporting ESD sensitive components such as replacement parts or parts to be returned to Dell, it is critical to place these parts in anti-static bags for safe transport.

## Lifting equipment

Adhere to the following guidelines when lifting heavy weight equipment:

**⚠ CAUTION: Do not lift greater than 50 pounds. Always obtain additional resources or use a mechanical lifting device.**

- 1 Get a firm balanced footing. Keep your feet apart for a stable base, and point your toes out.
- 2 Tighten stomach muscles. Abdominal muscles support your spine when you lift, offsetting the force of the load.
- 3 Lift with your legs, not your back.

- 4 Keep the load close. The closer it is to your spine, the less force it exerts on your back.
- 5 Keep your back upright, whether lifting or setting down the load. Do not add the weight of your body to the load. Avoid twisting your body and back.
- 6 Follow the same techniques in reverse to set the load down.

## ESD field service kit

The unmonitored Field Service kit is the most commonly used service kit. Each Field Service kit includes three main components: anti-static mat, wrist strap, and bonding wire.

## Components of an ESD field service kit

The components of an ESD field service kit are:

- **Anti-Static Mat** – The anti-static mat is dissipative and parts can be placed on it during service procedures. When using an anti-static mat, your wrist strap should be snug and the bonding wire should be connected to the mat and to any bare metal on the system being worked on. Once deployed properly, service parts can be removed from the ESD bag and placed directly on the mat. ESD-sensitive items are safe in your hand, on the ESD mat, in the system, or inside a bag.
- **Wrist Strap and Bonding Wire** – The wrist strap and bonding wire can be either directly connected between your wrist and bare metal on the hardware if the ESD mat is not required, or connected to the anti-static mat to protect hardware that is temporarily placed on the mat. The physical connection of the wrist strap and bonding wire between your skin, the ESD mat, and the hardware is known as bonding. Use only Field Service kits with a wrist strap, mat, and bonding wire. Never use wireless wrist straps. Always be aware that the internal wires of a wrist strap are prone to damage from normal wear and tear, and must be checked regularly with a wrist strap tester in order to avoid accidental ESD hardware damage. It is recommended to test the wrist strap and bonding wire at least once per week.
- **ESD Wrist Strap Tester** – The wires inside of an ESD strap are prone to damage over time. When using an unmonitored kit, it is a best practice to regularly test the strap prior to each service call, and at a minimum, test once per week. A wrist strap tester is the best method for doing this test. If you do not have your own wrist strap tester, check with your regional office to find out if they have one. To perform the test, plug the wrist-strap's bonding-wire into the tester while it is strapped to your wrist and push the button to test. A green LED is lit if the test is successful; a red LED is lit and an alarm sounds if the test fails.
- **Insulator Elements** – It is critical to keep ESD sensitive devices, such as plastic heat sink casings, away from internal parts that are insulators and often highly charged.
- **Working Environment** – Before deploying the ESD Field Service kit, assess the situation at the customer location. For example, deploying the kit for a server environment is different than for a desktop or portable environment. Servers are typically installed in a rack within a data center; desktops or portables are typically placed on office desks or cubicles. Always look for a large open flat work area that is free of clutter and large enough to deploy the ESD kit with additional space to accommodate the type of system that is being repaired. The workspace should also be free of insulators that can cause an ESD event. On the work area, insulators such as Styrofoam and other plastics should always be moved at least 12 inches or 30 centimeters away from sensitive parts before physically handling any hardware components.
- **ESD Packaging** – All ESD-sensitive devices must be shipped and received in static-safe packaging. Metal, static-shielded bags are preferred. However, you should always return the damaged part using the same ESD bag and packaging that the new part arrived in. The ESD bag should be folded over and taped shut and all the same foam packing material should be used in the original box that the new part arrived in. ESD-sensitive devices should be removed from packaging only at an ESD-protected work surface, and parts should never be placed on top of the ESD bag because only the inside of the bag is shielded. Always place parts in your hand, on the ESD mat, in the system, or inside an anti-static bag.
- **Transporting Sensitive Components** – When transporting ESD sensitive components such as replacement parts or parts to be returned to Dell, it is critical to place these parts in anti-static bags for safe transport.

## ESD protection summary

It is recommended that all field service technicians use the traditional wired ESD grounding wrist strap and protective anti-static mat at all times when servicing Dell products. In addition, it is critical that technicians keep sensitive parts separate from all insulator parts while performing service and that they use anti-static bags for transporting sensitive components.

# After working inside your computer

## About this task

After you complete any replacement procedure, ensure that you connect external devices, cards, and cables before turning on your computer.

 **CAUTION:** To avoid damage to the computer, use only the battery designed for this particular Dell computer. Do not use batteries designed for other Dell computers.

## Steps

- 1 Connect any external devices, such as a port replicator or media base, and replace any cards, such as an ExpressCard.
- 2 Connect any telephone or network cables to your computer.

 **CAUTION:** To connect a network cable, first plug the cable into the network device and then plug it into the computer.

- 3 Connect your computer and all attached devices to their electrical outlets.
- 4 Turn on your computer.

# Technology and components

**NOTE:** Instructions provided in this section are applicable on computers shipped with Windows 10 operating system. Windows 10 is factory-installed with this computer.

Topics:

- [DDR4](#)
- [HDMI 1.4](#)
- [USB features](#)
- [Intel Optane memory](#)

## DDR4

DDR4 (double data rate fourth generation) memory is a higher-speed successor to the DDR2 and DDR3 technologies and allows up to 512 GB in capacity, compared to the DDR3's maximum of 128 GB per DIMM. DDR4 synchronous dynamic random-access memory is keyed differently from both SDRAM and DDR to prevent the user from installing the wrong type of memory into the system.

DDR4 needs 20 percent less or just 1.2 volts, compared to DDR3 which requires 1.5 volts of electrical power to operate. DDR4 also supports a new, deep power-down mode that allows the host device to go into standby without needing to refresh its memory. Deep power-down mode is expected to reduce standby power consumption by 40 to 50 percent.

## DDR4 Details

There are subtle differences between DDR3 and DDR4 memory modules, as listed below.

Key notch difference

The key notch on a DDR4 module is in a different location from the key notch on a DDR3 module. Both notches are on the insertion edge but the notch location on the DDR4 is slightly different, to prevent the module from being installed into an incompatible board or platform.

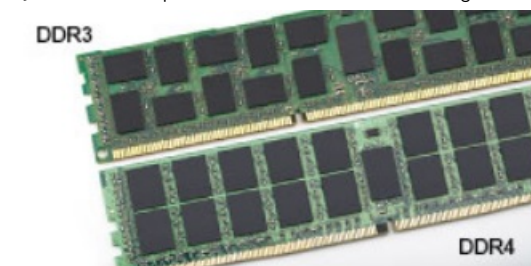

**Figure 1. Notch difference**

Increased thickness

DDR4 modules are slightly thicker than DDR3, to accommodate more signal layers.



**Figure 2. Thickness difference**

Curved edge

DDR4 modules feature a curved edge to help with insertion and alleviate stress on the PCB during memory installation.



**Figure 3. Curved edge**

## Memory Errors

Memory errors on the system display the new ON-FLASH-FLASH or ON-FLASH-ON failure code. If all memory fails, the LCD does not turn on. Troubleshoot for possible memory failure by trying known good memory modules in the memory connectors on the bottom of the system or under the keyboard, as in some portable systems.

**NOTE:** The DDR4 memory is imbedded in board and not a replaceable DIMM as shown and referred.

## HDMI 1.4

This topic explains the HDMI 1.4 and its features along with the advantages.

HDMI (High-Definition Multimedia Interface) is an industry-supported, uncompressed, all-digital audio/video interface. HDMI provides an interface between any compatible digital audio/video source, such as a DVD player, or A/V receiver and a compatible digital audio and/or video monitor, such as a digital TV (DTV). The intended applications for HDMI TVs, and DVD players. The primary advantage is cable reduction and content protection provisions. HDMI supports standard, enhanced, or high-definition video, plus multichannel digital audio on a single cable.

**NOTE:** The HDMI 1.4 will provide 5.1 channel audio support.

## HDMI 1.4 Features

- **HDMI Ethernet Channel** - Adds high-speed networking to an HDMI link, allowing users to take full advantage of their IP-enabled devices without a separate Ethernet cable
- **Audio Return Channel** - Allows an HDMI-connected TV with a built-in tuner to send audio data "upstream" to a surround audio system, eliminating the need for a separate audio cable
- **3D** - Defines input/output protocols for major 3D video formats, paving the way for true 3D gaming and 3D home theater applications
- **Content Type** - Real-time signaling of content types between display and source devices, enabling a TV to optimize picture settings based on content type

- **Additional Color Spaces** - Adds support for additional color models used in digital photography and computer graphics
- **4K Support** - Enables video resolutions far beyond 1080p, supporting next-generation displays that will rival the Digital Cinema systems used in many commercial movie theaters
- **HDMI Micro Connector** - A new, smaller connector for phones and other portable devices, supporting video resolutions up to 1080p
- **Automotive Connection System** - New cables and connectors for automotive video systems, designed to meet the unique demands of the motoring environment while delivering true HD quality

## Advantages of HDMI

- Quality HDMI transfers uncompressed digital audio and video for the highest, crispest image quality.
- Low -cost HDMI provides the quality and functionality of a digital interface while also supporting uncompressed video formats in a simple, cost-effective manner
- Audio HDMI supports multiple audio formats from standard stereo to multichannel surround sound
- HDMI combines video and multichannel audio into a single cable, eliminating the cost, complexity, and confusion of multiple cables currently used in A/V systems
- HDMI supports communication between the video source (such as a DVD player) and the DTV, enabling new functionality

## USB features

Universal Serial Bus, or USB, was introduced in 1996. It dramatically simplified the connection between host computers and peripheral devices like mice, keyboards, external drivers, and printers.

Let's take a quick look on the USB evolution referencing to the table below.

**Table 1. USB evolution**

Type	Data Transfer Rate	Category	Introduction Year
USB 2.0	480 Mbps	High Speed	2000
USB 3.0/USB 3.1 Gen 1	5 Gbps	Super Speed	2010
USB 3.1 Gen 2	10 Gbps	Super Speed	2013

## USB 3.0/USB 3.1 Gen 1 (SuperSpeed USB)

For years, the USB 2.0 has been firmly entrenched as the de facto interface standard in the PC world with about 6 billion devices sold, and yet the need for more speed grows by ever faster computing hardware and ever greater bandwidth demands. The USB 3.0/USB 3.1 Gen 1 finally has the answer to the consumers' demands with a theoretically 10 times faster than its predecessor. In a nutshell, USB 3.1 Gen 1 features are as follows:

- Higher transfer rates (up to 5 Gbps)
- Increased maximum bus power and increased device current draw to better accommodate power-hungry devices
- New power management features
- Full-duplex data transfers and support for new transfer types
- Backward USB 2.0 compatibility
- New connectors and cable

The topics below cover some of the most commonly asked questions regarding USB 3.0/USB 3.1 Gen 1.



# Speed

Currently, there are 3 speed modes defined by the latest USB 3.0/USB 3.1 Gen 1 specification. They are Super-Speed, Hi-Speed and Full-Speed. The new SuperSpeed mode has a transfer rate of 4.8Gbps. While the specification retains Hi-Speed, and Full-Speed USB mode, commonly known as USB 2.0 and 1.1 respectively, the slower modes still operate at 480Mbps and 12Mbps respectively and are kept to maintain backward compatibility.

USB 3.0/USB 3.1 Gen 1 achieves the much higher performance by the technical changes below:

- An additional physical bus that is added in parallel with the existing USB 2.0 bus (refer to the picture below).
- USB 2.0 previously had four wires (power, ground, and a pair for differential data); USB 3.0/USB 3.1 Gen 1 adds four more for two pairs of differential signals (receive and transmit) for a combined total of eight connections in the connectors and cabling.
- USB 3.0/USB 3.1 Gen 1 utilizes the bidirectional data interface, rather than USB 2.0's half-duplex arrangement. This gives a 10-fold increase in theoretical bandwidth.

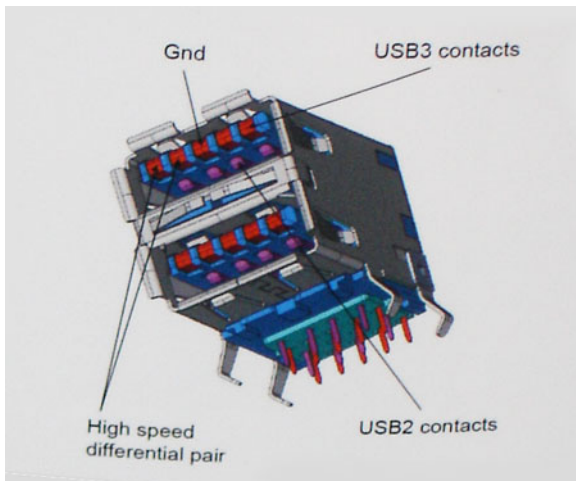

With today's ever increasing demands placed on data transfers with high-definition video content, terabyte storage devices, high megapixel count digital cameras etc., USB 2.0 may not be fast enough. Furthermore, no USB 2.0 connection could ever come close to the 480Mbps theoretical maximum throughput, making data transfer at around 320Mbps (40MB/s) — the actual real-world maximum. Similarly, USB 3.0/USB 3.1 Gen 1 connections will never achieve 4.8Gbps. We will likely see a real-world maximum rate of 400MB/s with overheads. At this speed, USB 3.0/USB 3.1 Gen 1 is a 10x improvement over USB 2.0.

# Applications

USB 3.0/USB 3.1 Gen 1 opens up the laneways and provides more headroom for devices to deliver a better overall experience. Where USB video was barely tolerable previously (both from a maximum resolution, latency, and video compression perspective), it's easy to imagine that with 5-10 times the bandwidth available, USB video solutions should work that much better. Single-link DVI requires almost 2Gbps throughput. Where 480Mbps was limiting, 5Gbps is more than promising. With its promised 4.8Gbps speed, the standard will find its way into some products that previously weren't USB territory, like external RAID storage systems.

Listed below are some of the available SuperSpeed USB 3.0/USB 3.1 Gen 1 products:

- External Desktop USB 3.0/USB 3.1 Gen 1 Hard Drives
- Portable USB 3.0/USB 3.1 Gen 1 Hard Drives
- USB 3.0/USB 3.1 Gen 1 Drive Docks & Adapters
- USB 3.0/USB 3.1 Gen 1 Flash Drives & Readers
- USB 3.0/USB 3.1 Gen 1 Solid-state Drives

- USB 3.0/USB 3.1 Gen 1 RAIDs
- Optical Media Drives
- Multimedia Devices
- Networking
- USB 3.0/USB 3.1 Gen 1 Adapter Cards & Hubs

## Compatibility

The good news is that USB 3.0/USB 3.1 Gen 1 has been carefully planned from the start to peacefully co-exist with USB 2.0. First of all, while USB 3.0/USB 3.1 Gen 1 specifies new physical connections and thus new cables to take advantage of the higher speed capability of the new protocol, the connector itself remains the same rectangular shape with the four USB 2.0 contacts in the exact same location as before. Five new connections to carry receive and transmitted data independently are present on USB 3.0/USB 3.1 Gen 1 cables and only come into contact when connected to a proper SuperSpeed USB connection.

Windows 10 will be bringing native support for USB 3.1 Gen 1 controllers. This is in contrast to previous versions of Windows, which continue to require separate drivers for USB 3.0/USB 3.1 Gen 1 controllers.

## Intel Optane memory

Intel Optane memory functions only as a storage accelerator. It neither replaces nor adds to the memory (RAM) installed on your computer.

**NOTE:** Intel Optane memory is supported on computers that meet the following requirements:

- 7th Generation or higher Intel Core i3/i5/i7 processor
- Windows 10 64-bit version or higher
- Intel Rapid Storage Technology driver version 15.9.1.1018 or higher

**Table 2. Intel Optane memory specifications**

Feature	Specifications
Interface	PCIe 3x2 NVMe 1.1
Connector	M.2 card slot (2230/2280)
Configurations supported	<ul style="list-style-type: none"> <li>• 7th Generation or higher Intel Core i3/i5/i7 processor</li> <li>• Windows 10 64-bit version or higher</li> <li>• Intel Rapid Storage Technology driver version 15.9.1.1018 or higher</li> </ul>
Capacity	16 GB

## Enabling Intel Optane memory

- 1 On the taskbar, click the search box, and type **"Intel Rapid Storage Technology"**.
- 2 Click **Intel Rapid Storage Technology**.
- 3 On the **Status** tab, click **Enable** to enable the Intel Optane memory.
- 4 On the warning screen, select a compatible fast drive, and then click **Yes** to continue enabling Intel Optane memory.
- 5 Click **Intel Optane memory > Reboot** to enable the Intel Optane memory.

**NOTE:** Applications may take up to three subsequent launches after enablement to see the full performance benefits.

# Disabling Intel Optane memory

## About this task

 **CAUTION:** After disabling Intel Optane memory, do not uninstall the driver for Intel Rapid Storage Technology as it will result in a blue screen error. The Intel Rapid Storage Technology user interface can be removed without uninstalling the driver.

 **NOTE:** Disabling Intel Optane memory is required before removing the SATA storage device, accelerated by the Intel Optane memory module, from the computer.

## Steps

- 1 On the taskbar, click the search box, and then type "**Intel Rapid Storage Technology**".
- 2 Click **Intel Rapid Storage Technology**. The **Intel Rapid Storage Technology** window is displayed.
- 3 On the **Intel Optane memory** tab, click **Disable** to disable the Intel Optane memory.
- 4 Click **Yes** if you accept the warning.  
The disabling progress is displayed.
- 5 Click **Reboot** to complete disabling Intel Optane memory and restart your computer.

# Removing and installing components

## Recommended tools













The procedures in this document may require the following tools:

- Phillips #00 and #01 screwdriver
- Plastic scribe

## Screw list

The following table provides the list of screws that are used for securing different components.

**Table 3. Screw list**

Component	Screw type	Quantity	Screw image
Base cover	M2x4	1	
	M2.5x7	6	
Battery	M2x3	4	
Hard drive assembly	M2x3	4	
Hard drive bracket	M3x3	4	
WLAN card bracket	M2x3	1	
Display assembly	M2.5x5	5	
Display panel	M2x2	4	
Display hinges	M2.5x2.5	8	
	M2x2	2	
Touchpad	M2x2	4	
Power button board	M2x3	1	
Thermal plate	M2x3	2	

Component	Screw type	Quantity	Screw image
Power-adapter port	M2x3	1	
I/O board	M2x4	2	
Power button	M2x2	1	
Solid-state drive	M2x2	1	
System board	M2x4	1	
Wireless-antenna bracket	M2x4	2	

## SD card

### Removing the SD card

#### Prerequisite

- 1 Follow the procedure in [Before working inside your computer.](#)

#### Steps

- 1 Push the SD card to release it from the computer.
- 2 Slide the SD card out of the computer.



# Installing the SD card

## Step

Slide the Secure Digital into the slot until it clicks into place.



## Next step

- 1 Follow the procedure in [after working inside your computer](#).

# Base cover

## Removing the base cover

### Prerequisites

- 1 Follow the procedure in [Before working inside your computer](#).
- 2 Remove the [SD card](#).

### Steps

- 1 Loosen the three captive screws that secure the base cover to the system [1].
- 2 Remove the six (M2.5x7) screws that secure the base cover to the system [2].
- 3 Remove the screw (M2x4) that secure the base cover to the system [3].

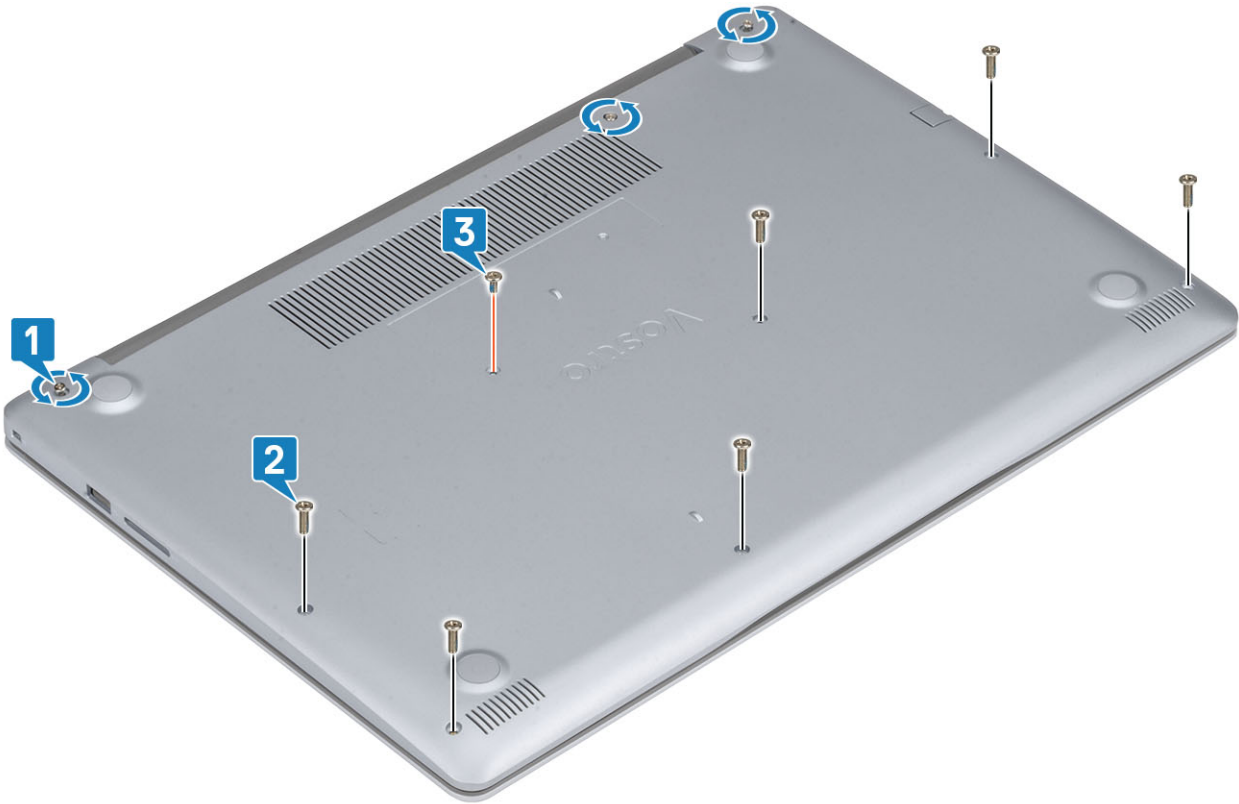

4 Pry the base cover from the top-left corner [1] and continue to pry open the sides of the base cover [2, 3, 4].



## Installing the base cover

### Steps

- 1 Place the base cover on the palmrest and keyboard assembly [1].
- 2 Press on the edges and sides of the base cover till it snaps into place [2, 3, 4]



- 3 Tighten the three captive screws, replace the six (M2.5x7) screws and the single (M2x4) screw that secure the base cover to the palmrest and keyboard assembly [1, 2, 3].

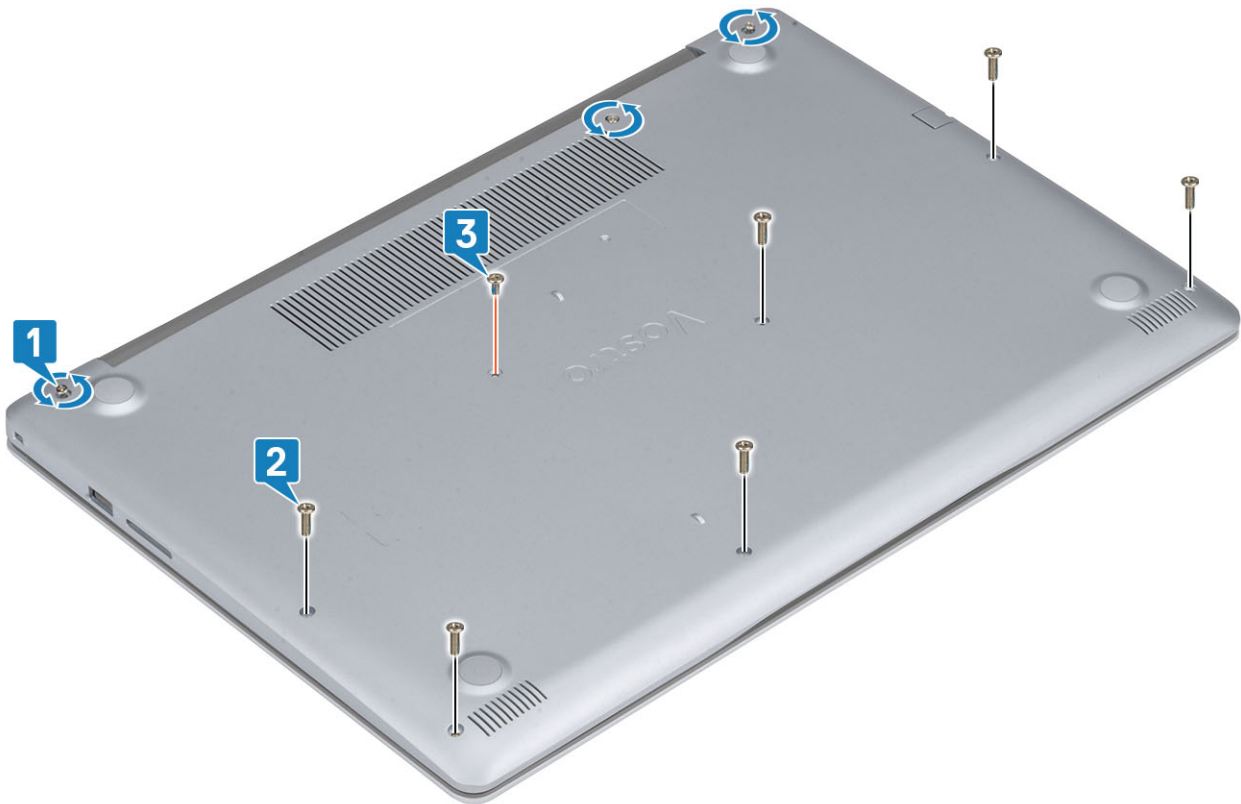

#### Next steps

- 1 Install the [SD card](#)
- 2 Follow the procedure in [after working inside your computer](#)

## Battery

### Removing the battery

- 1 Follow the procedure in [Before working inside your computer](#).
- 2 Remove the [base cover](#).
- 3 Disconnect the battery cable from the connector on the system board [1].
- 4 Remove the four (M2x3) screws securing the battery to the palm rest and keyboard assembly [2].
- 5 Lift the battery off the palm rest and keyboard assembly [3].

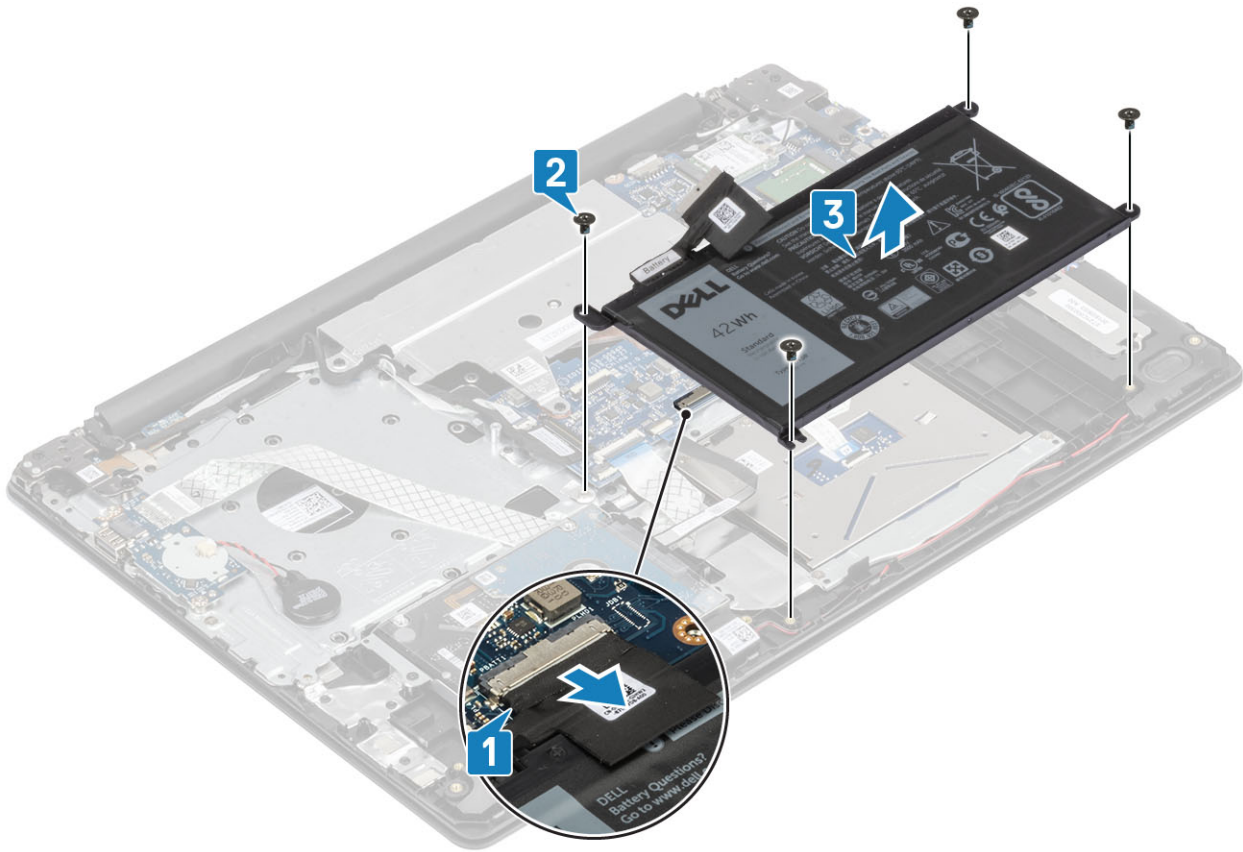

## Installing the battery

### Steps

- 1 Align the screw holes on the battery with the screw holes on the palm rest assembly [1].
- 2 Replace the four screws to secure the battery to the system [2].
- 3 Connect the battery cable to its connector on the system board [3].

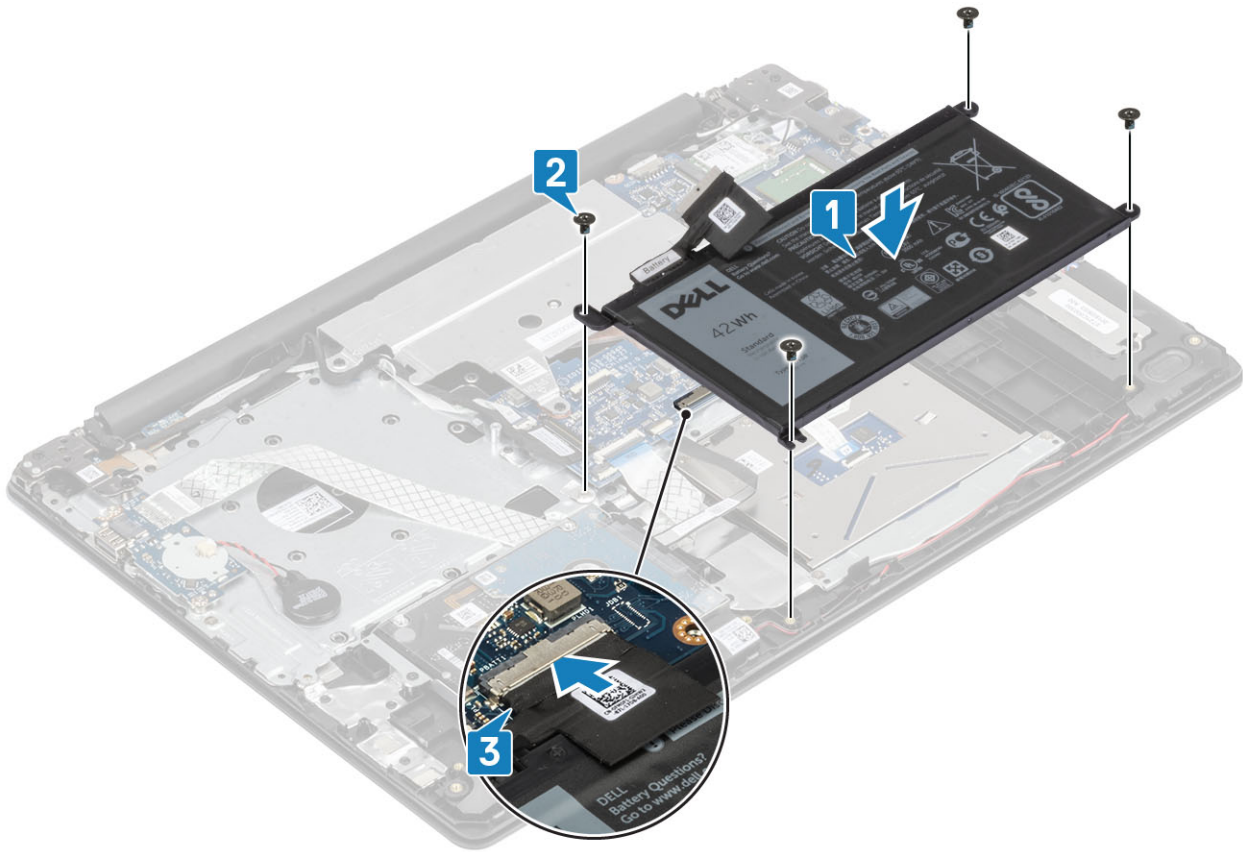

### Next steps

- 1 Install the [Base cover](#):
- 2 Follow the procedures in [After working inside your computer](#).

## Memory modules

### Removing the memory module

#### Prerequisite

- 1 Follow the procedure in [Before working inside your computer](#).
- 2 Remove the [SD card](#).
- 3 Remove the [base cover](#).
- 4 Remove the [battery](#)

#### Steps

- 1 Pull the clips securing the memory module until the memory module pops up [1].
- 2 Remove the memory module from the system board [2].

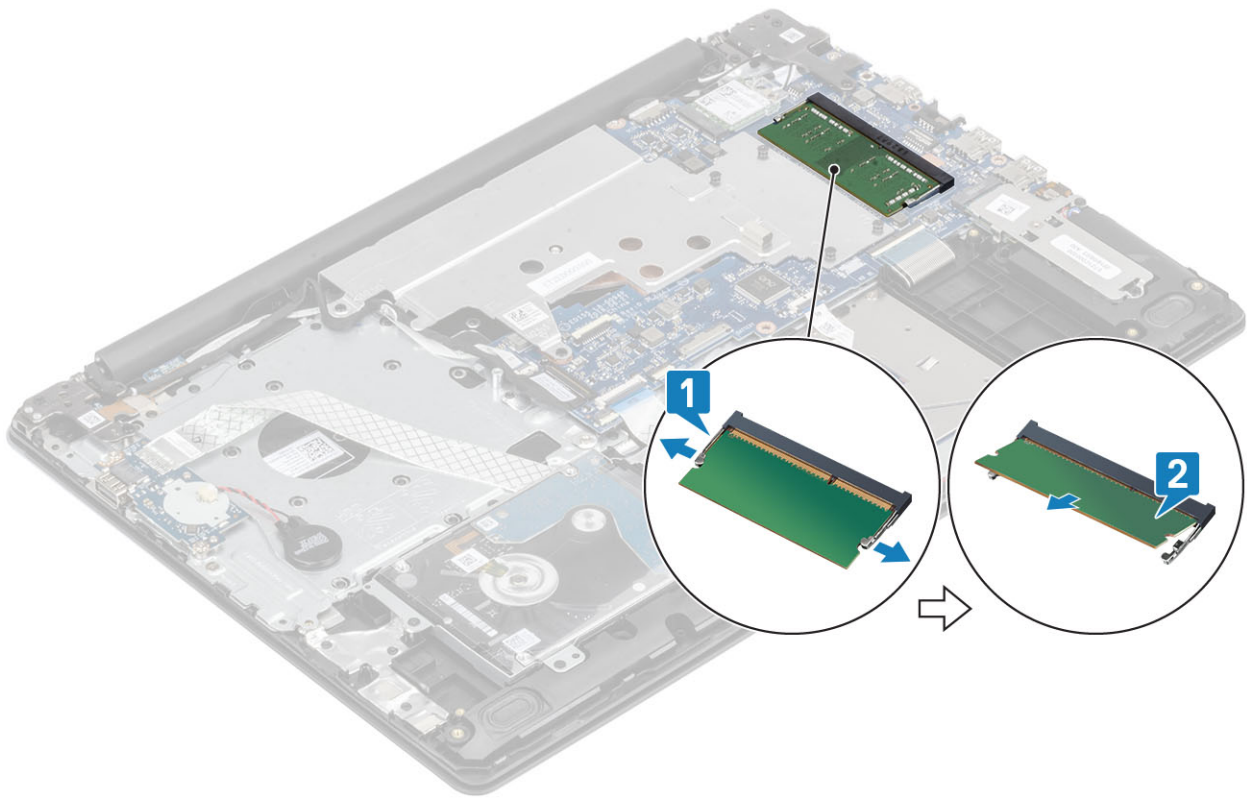

## Installing the memory module

### Steps

- 1 Insert the memory module into the memory socket [1].
- 2 Press the memory module until the clips secure the memory module [2].

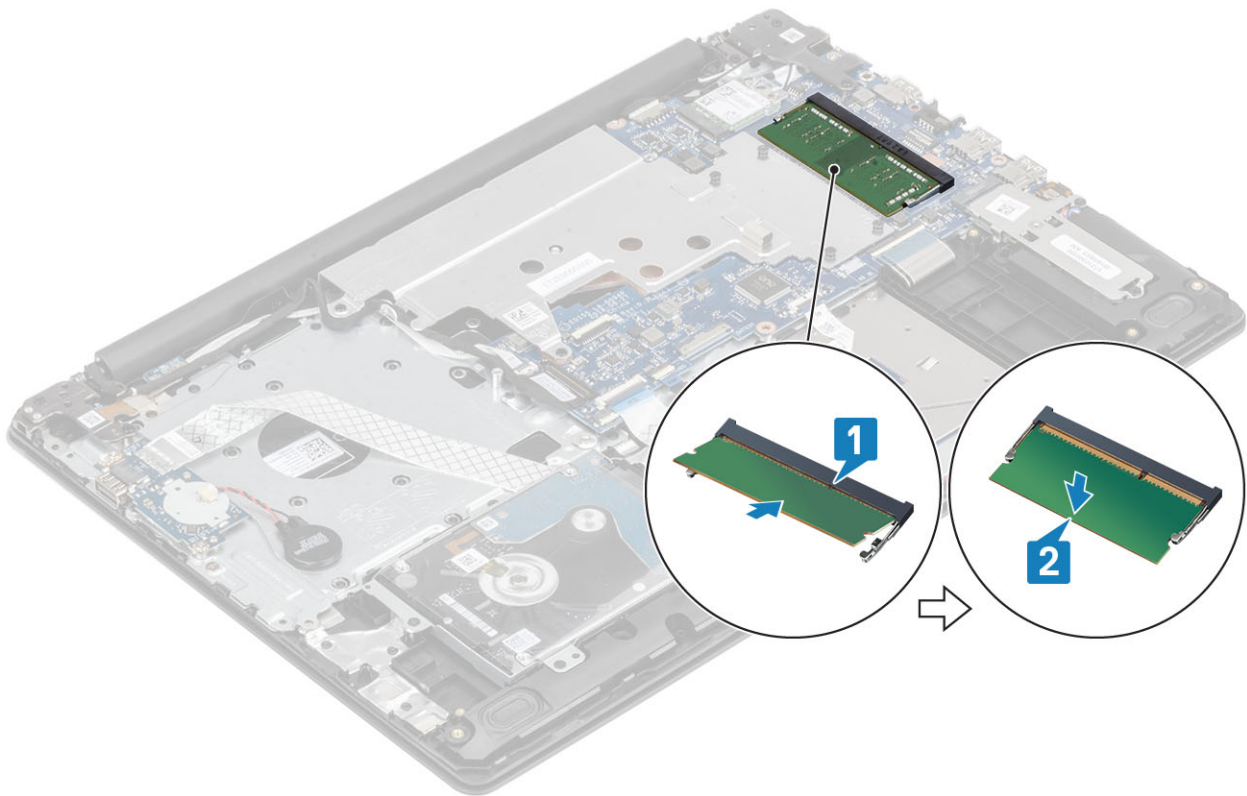

### Next steps

- 1 Install the [battery](#).
- 2 Install the [base cover](#).
- 3 Install the [SD card](#).
- 4 Follow the procedures in [After working inside your computer](#).

## M2. SATA Solid State Drive (SSD)

### Removing the M.2 2280 solid state drive

#### Prerequisite

- 1 Follow the procedure in [Before working inside your computer](#).
- 2 Remove the [SD card](#).
- 3 Remove the [base cover](#).
- 4 Remove the [battery](#)

#### Steps

- 1 Loosen the captive screws that secure the SSD thermal plate and solid-state drive to the palm rest and keyboard assembly [1].
- 2 Remove the single (M2x3) screw that secures the SSD to the system [2].
- 3 Lift the SSD thermal plate from its connector and lift it off the system [3].
- 4 Pull the SSD thermal plate from its connector on the system board. [4]

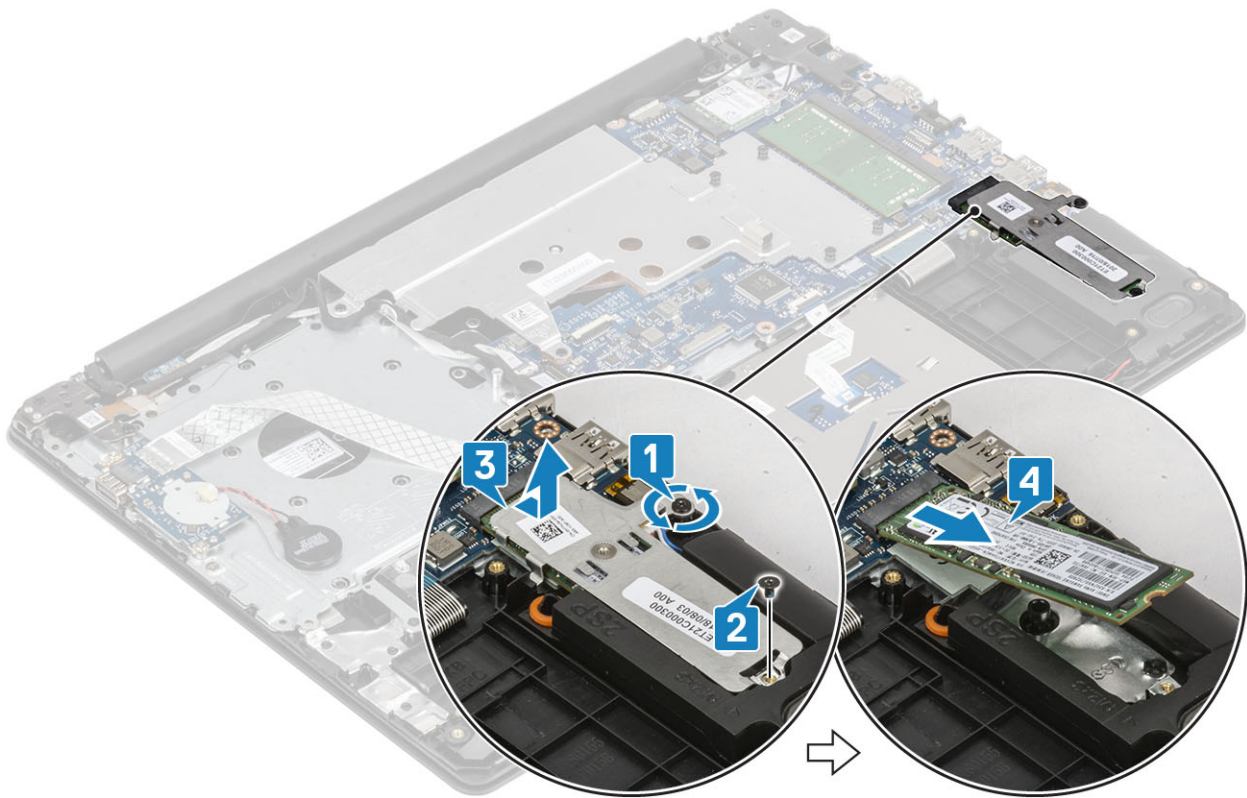

## Installing the M.2 2280 Solid state drive

### Steps

- 1 Slide and insert the solid-state drive into the solid-state drive slot [1].
- 2 Place the thermal pad on the SSD as shown in the image [2].
- 3 Tighten the captive screw that secures the thermal plate to the palmrest and keyboard assembly [3].
- 4 Replace the single (M2x3) screw that secures the thermal plate to the palmrest and keyboard assembly [4].

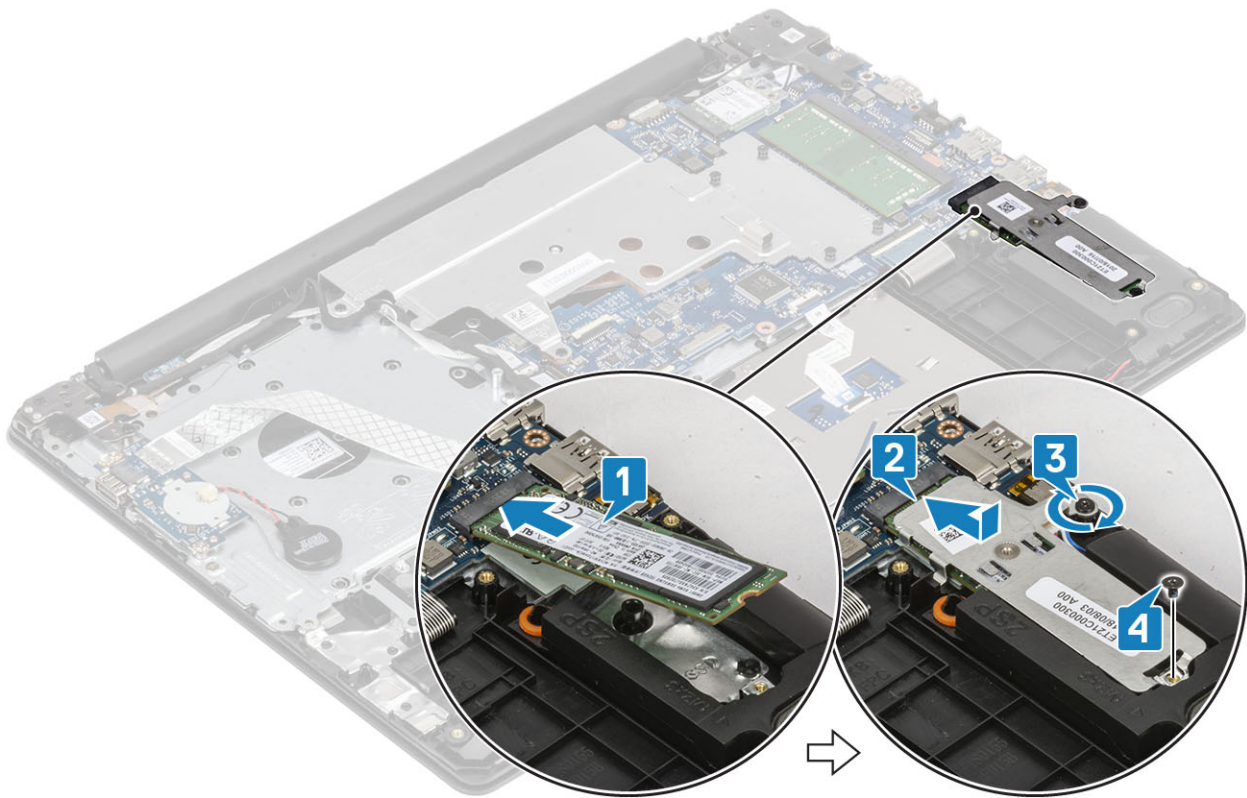

### Next steps

- 1 Install the [battery](#).
- 2 Install the [base cover](#).
- 3 Install the [SD card](#).
- 4 Follow the procedures in [After working inside your computer](#).

## Removing the M.2 2230 Solid state drive

### Prerequisite

- 1 Follow the procedure in [Before working inside your computer](#).
- 2 Remove the [SD card](#).
- 3 Remove the [base cover](#).
- 4 Remove the [battery](#)

### Steps

- 1 Loosen the captive screws that secure the SSD thermal plate and solid-state drive to the palm rest and keyboard assembly [1].
- 2 Remove the screw that secures the SSD to the system [2].
- 3 Slide the SSD thermal plate from its connector and lift it off the system [3].

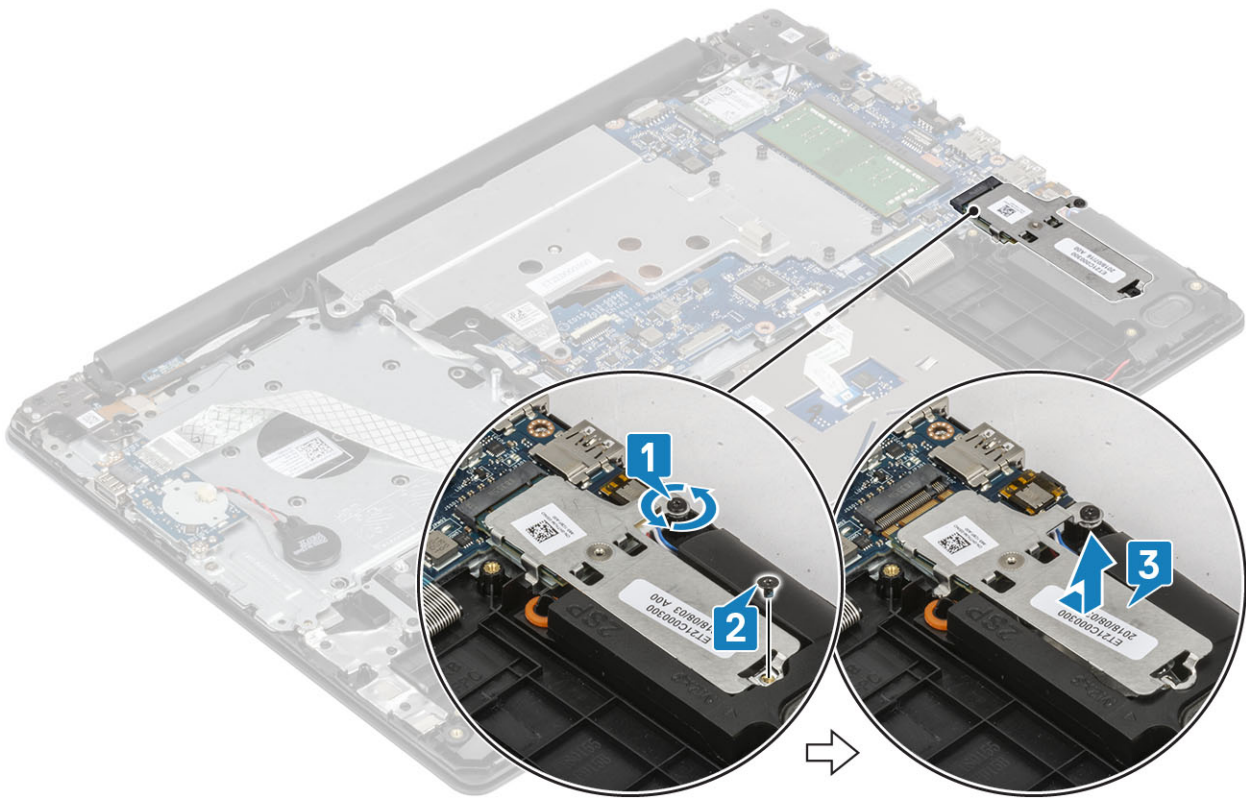

- 4 Turn the thermal plate over.
- 5 Remove the (M2x2) screw that secures the solid-state drive to the thermal plate [1].
- 6 Lift the solid-state drive off the thermal plate [2].

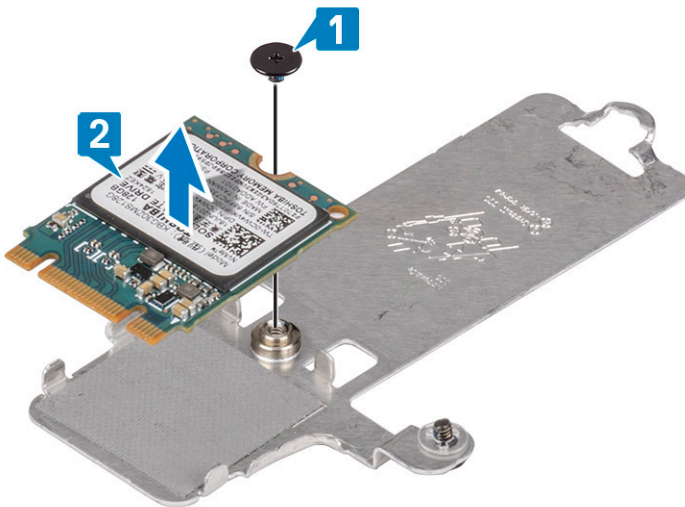

## Installing the M.2 2230 Solid state drive

### Steps

- 1 Place the solid-state drive into the slot of the thermal plate [1]
- 2 Replace the single (M2x2) screw that secures the solid-state drive to the thermal plate [2].

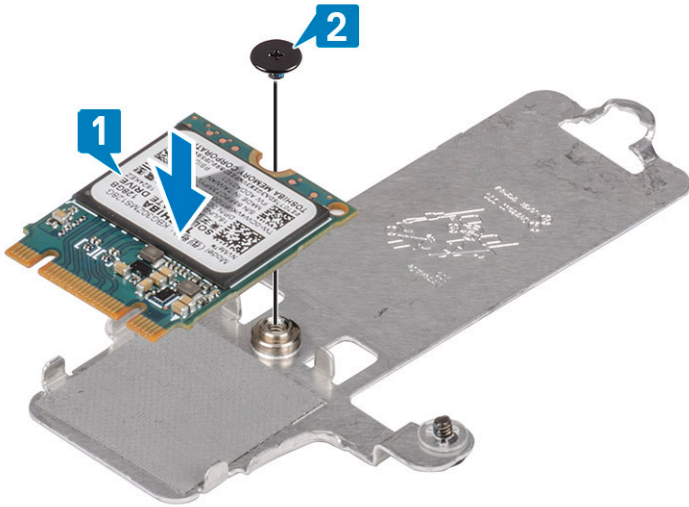

- 3 Slide and insert the solid-state drive thermal plate into the solid-state drive slot [1].
- 4 Tighten the captive screw that secures the thermal plate to the palmrest and keyboard assembly [2].
- 5 Replace the (M2x3) screw that secures the thermal plate to the palmrest and keyboard assembly [3].

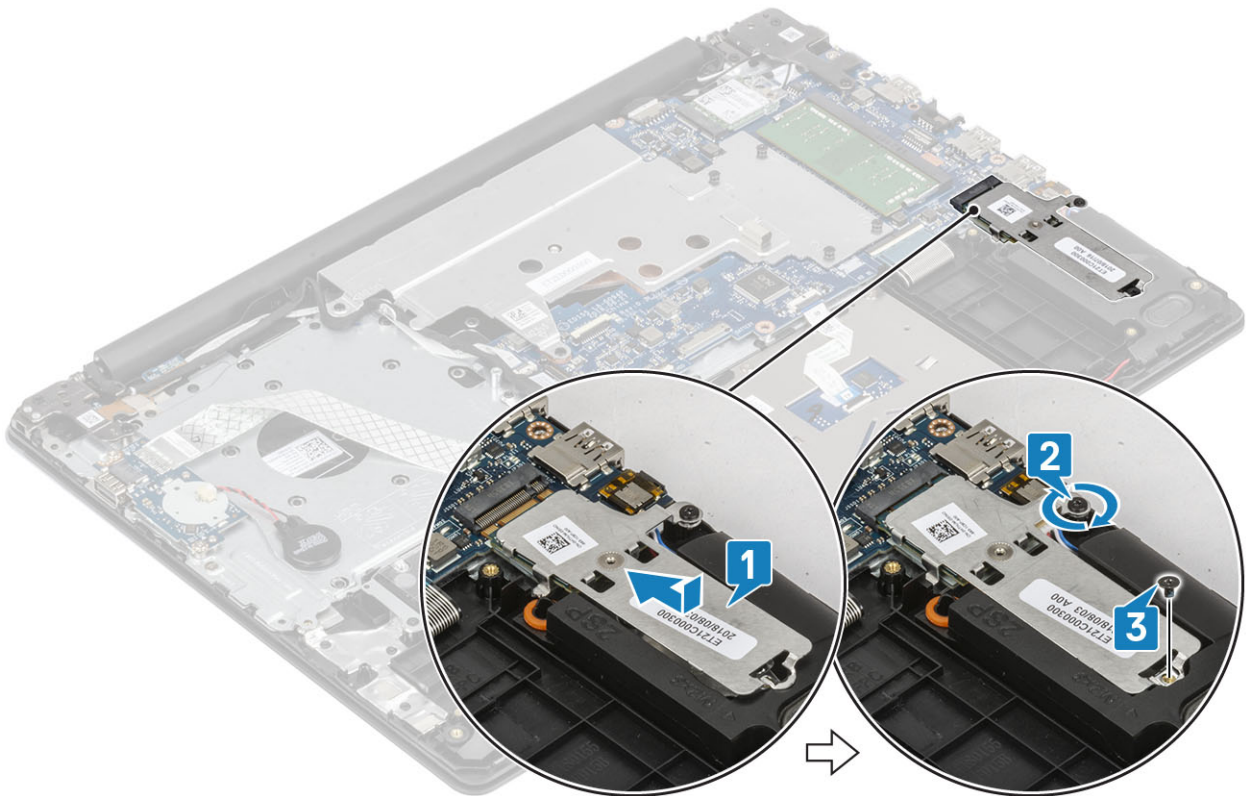

### Next steps

- 1 Install the [battery](#).
- 2 Install the [base cover](#).
- 3 Install the [SD card](#).
- 4 Follow the procedures in [After working inside your computer](#).

# I/O board

## Removing the I/O board

- 1 Disconnect the coin-cell battery cable from the I/O board [1].
- 2 Open the latch and disconnect the I/O-board cable from the system board [2].

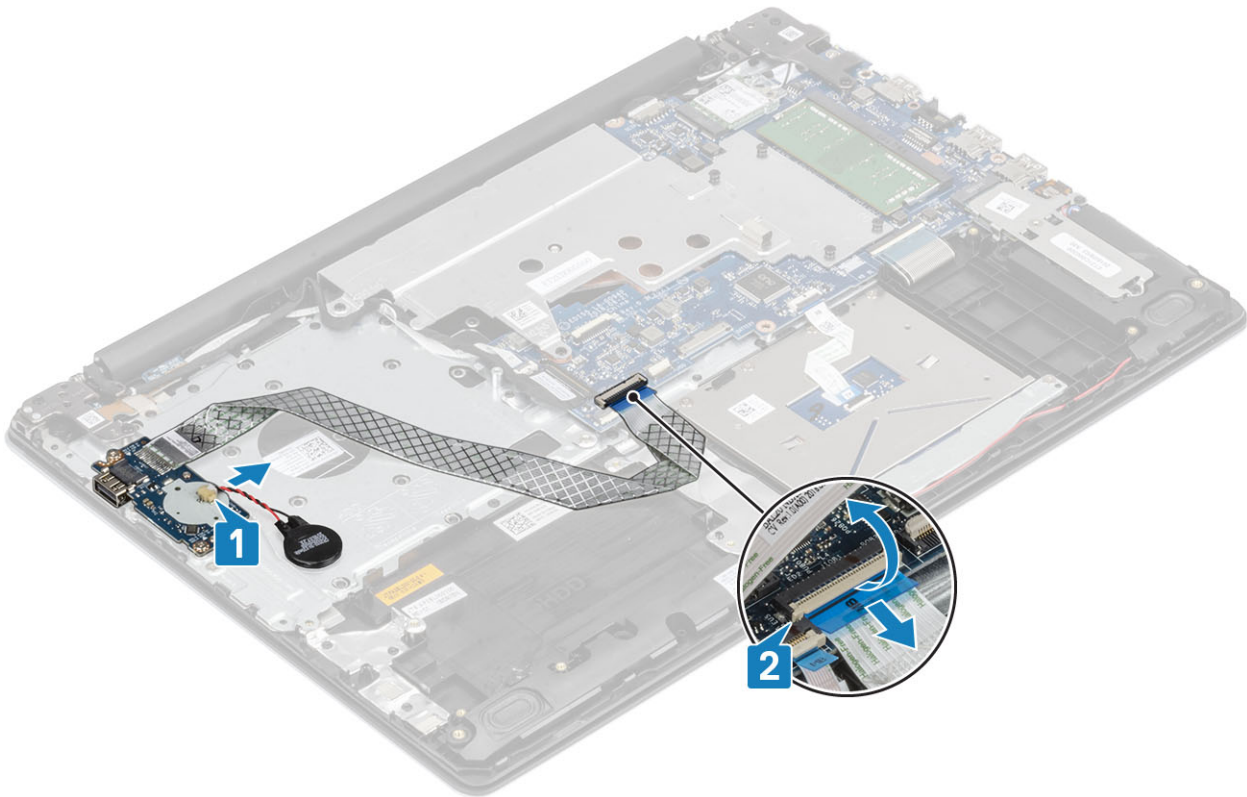

- 3 Remove the two screws (M2x4) that secure the I/O board to the palm rest and keyboard assembly [1].
- 4 Lift the I/O board off the palm rest and keyboard assembly [2].

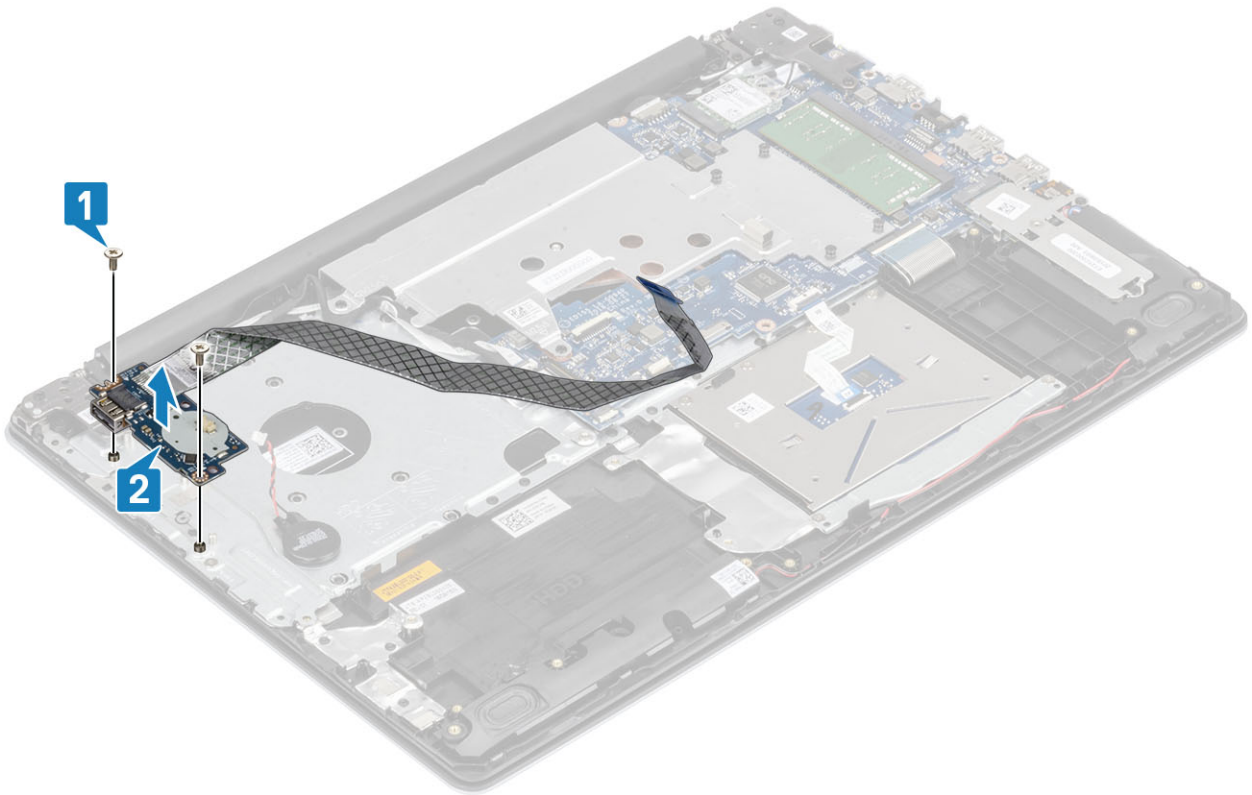

## Installing the I/O board

- 1 Using the alignment posts, place the I/O board on the palm rest and keyboard assembly [1].
- 2 Replace the two screws (M2x4) that secure the I/O board to the palm rest and keyboard assembly [2].

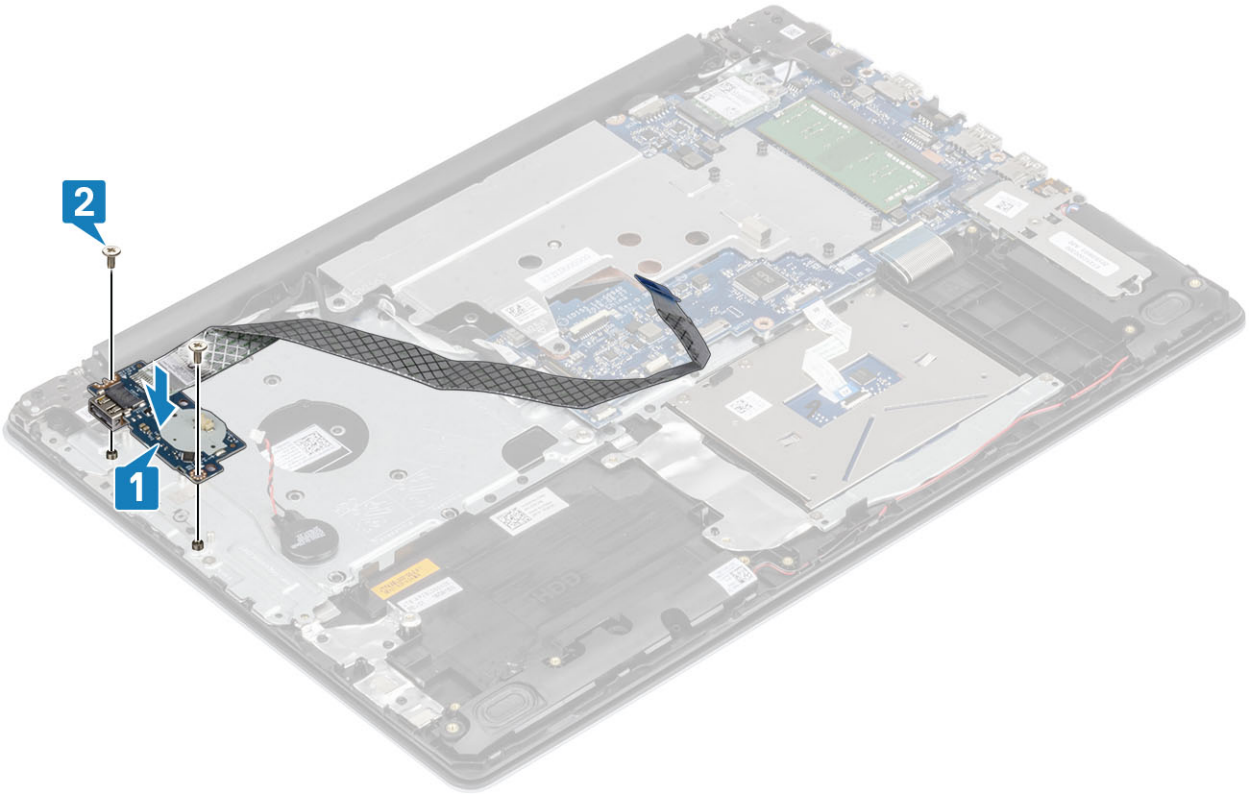

- 3 Connect the coin-cell battery cable to the I/O board [1].
- 4 Connect the I/O-board cable to the system board and close the latch to secure the cable [2].

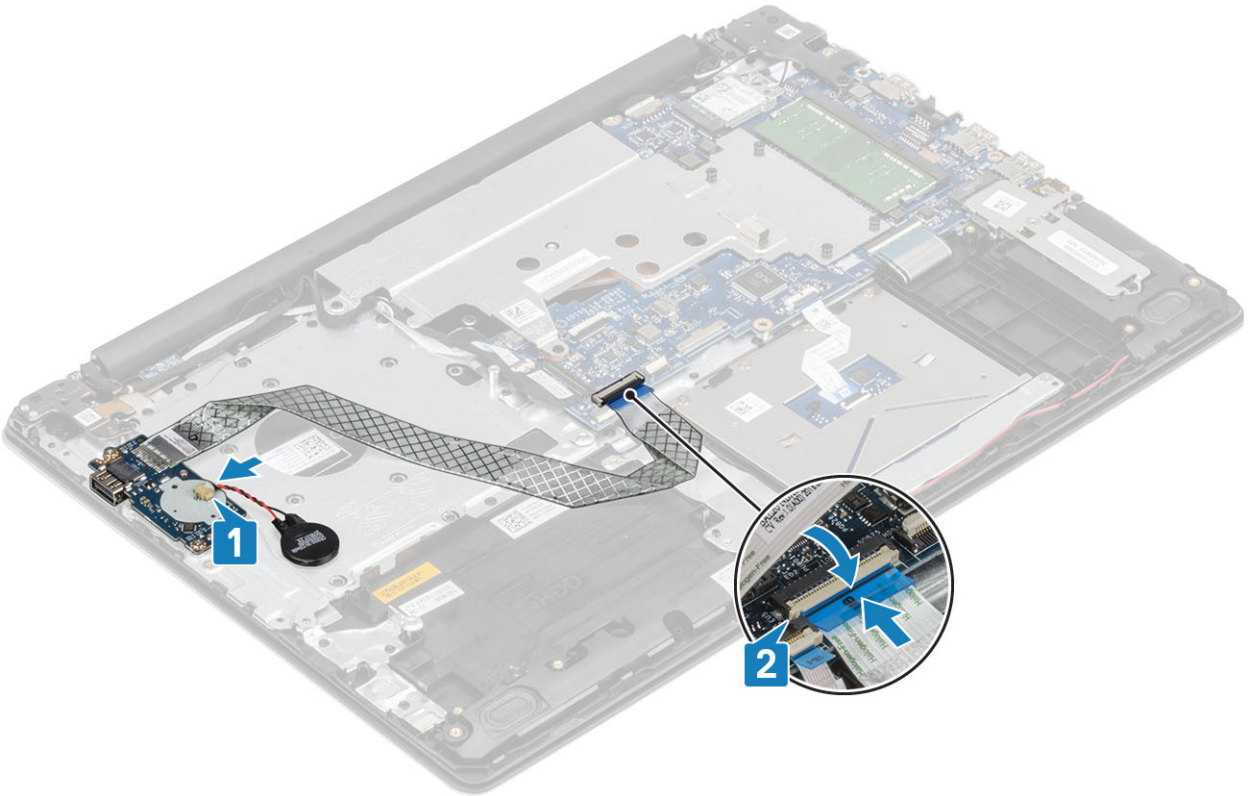

# Touchpad

## Removing the touchpad

### Prerequisite

- 1 Follow the procedure in [Before working inside your computer](#).
- 2 Remove the [SD card](#).
- 3 Remove the [base cover](#).
- 4 Remove the [battery](#)

### Steps

- 1 Open the latch and disconnect the hard-drive cable from the system board [1].
- 2 Open the latch and disconnect the touchpad cable from the system board [2].
- 3 Gently peel the tape that secures the touchpad to the palm rest and keyboard assembly [3].

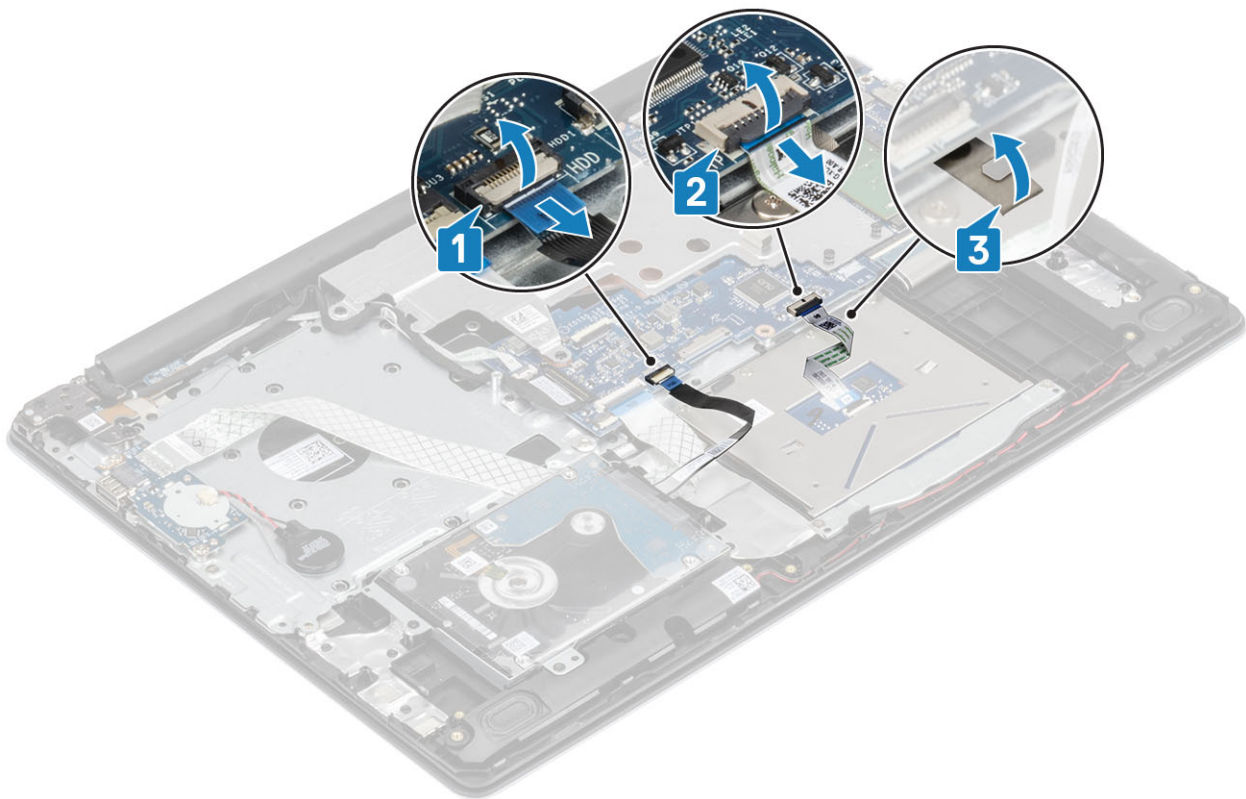

- 4 Remove the two screws (M2x2) that secure the touchpad bracket to the system [1].
- 5 Lift the touchpad bracket off the system [2]

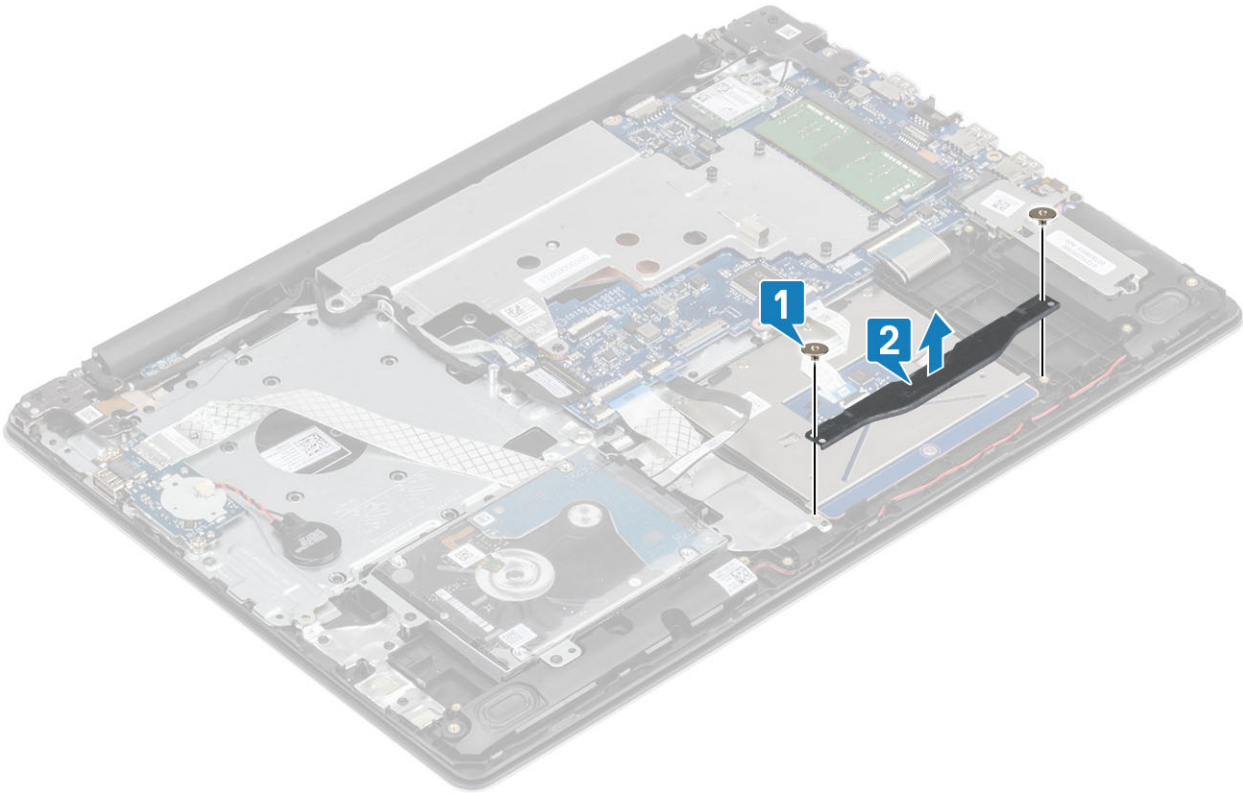

- 6 Remove the four screws (M2x2) that secure the touchpad to the palm rest and keyboard assembly [1].
- 7 Lift the touchpad off the palm rest and keyboard assembly [2].

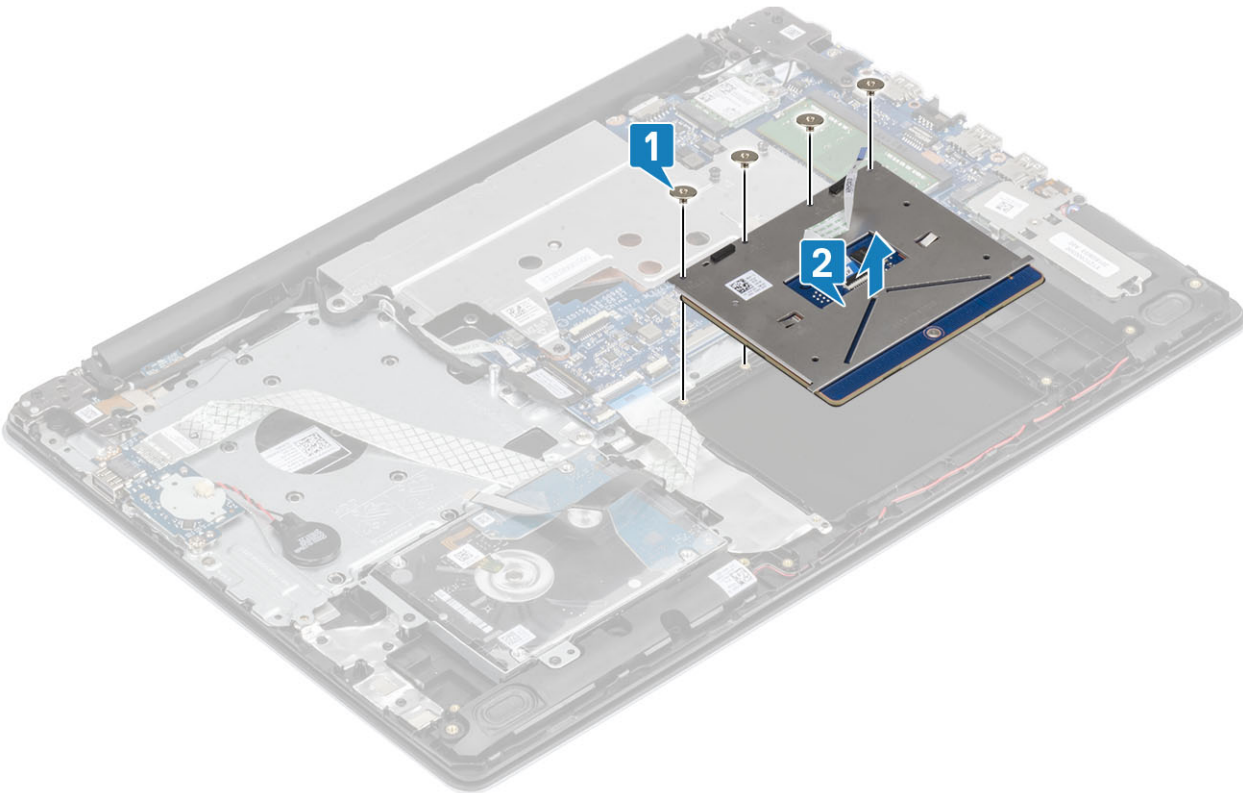

# Installing the touchpad

## About this task

**NOTE:** Ensure that the touchpad is aligned with the guides available on the palm-rest and keyboard assembly, and the gap on either sides of the touchpad is equal.

## Steps

- 1 Place the touchpad into the slot on the palm rest and keyboard assembly [1].
- 2 Replace the four screws (M2x2) that secure the touchpad to the palm rest and keyboard assembly [2].

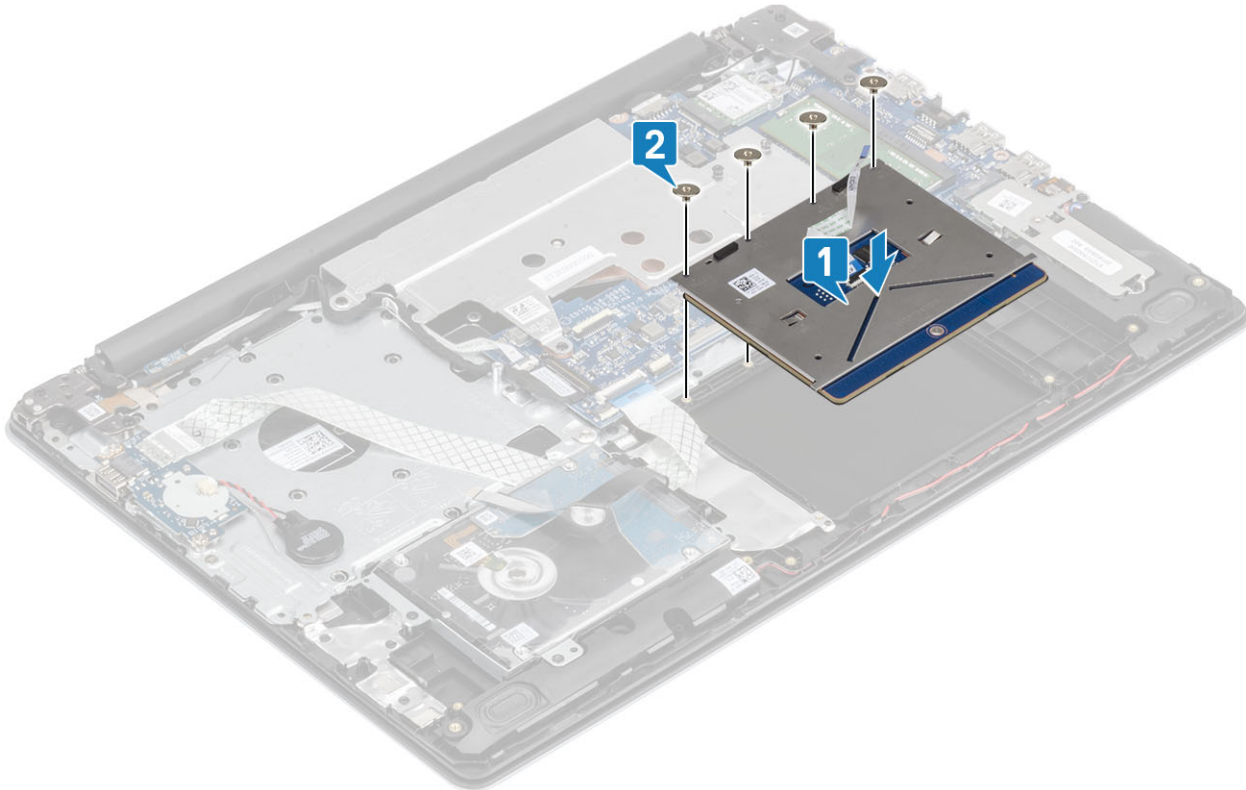

- 3 Align and place the touchpad bracket with the screw holes on the palm-rest and keyboard assembly [1].
- 4 Replace the two screws (M2x2) to secure the touchpad bracket to the palm-rest and keyboard assembly [2]

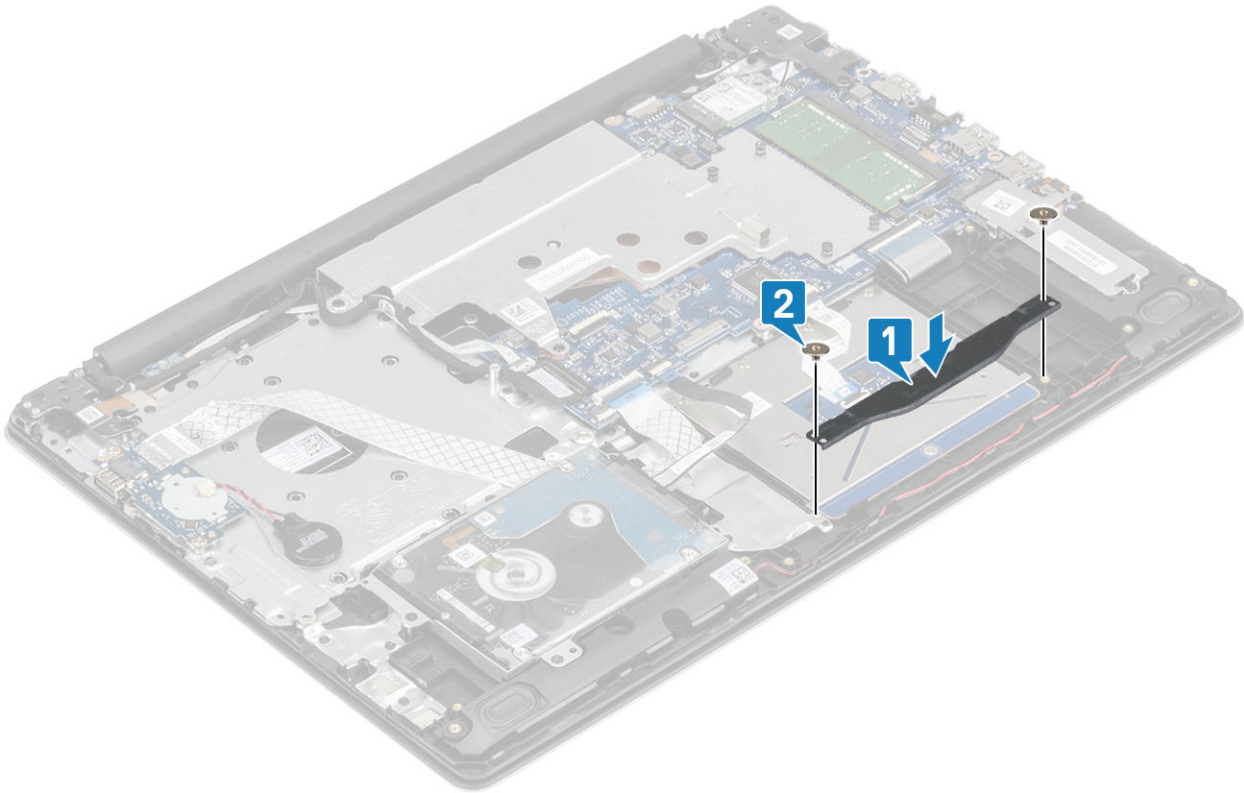

- 5 Affix the tape that secures the touchpad to the palm rest and keyboard assembly [1].
- 6 Slide the touchpad cable into the connector on the system board and close the latch to secure the cable [2].
- 7 Slide the hard-drive cable into the connector on the system board and close the latch to secure the cable [3].

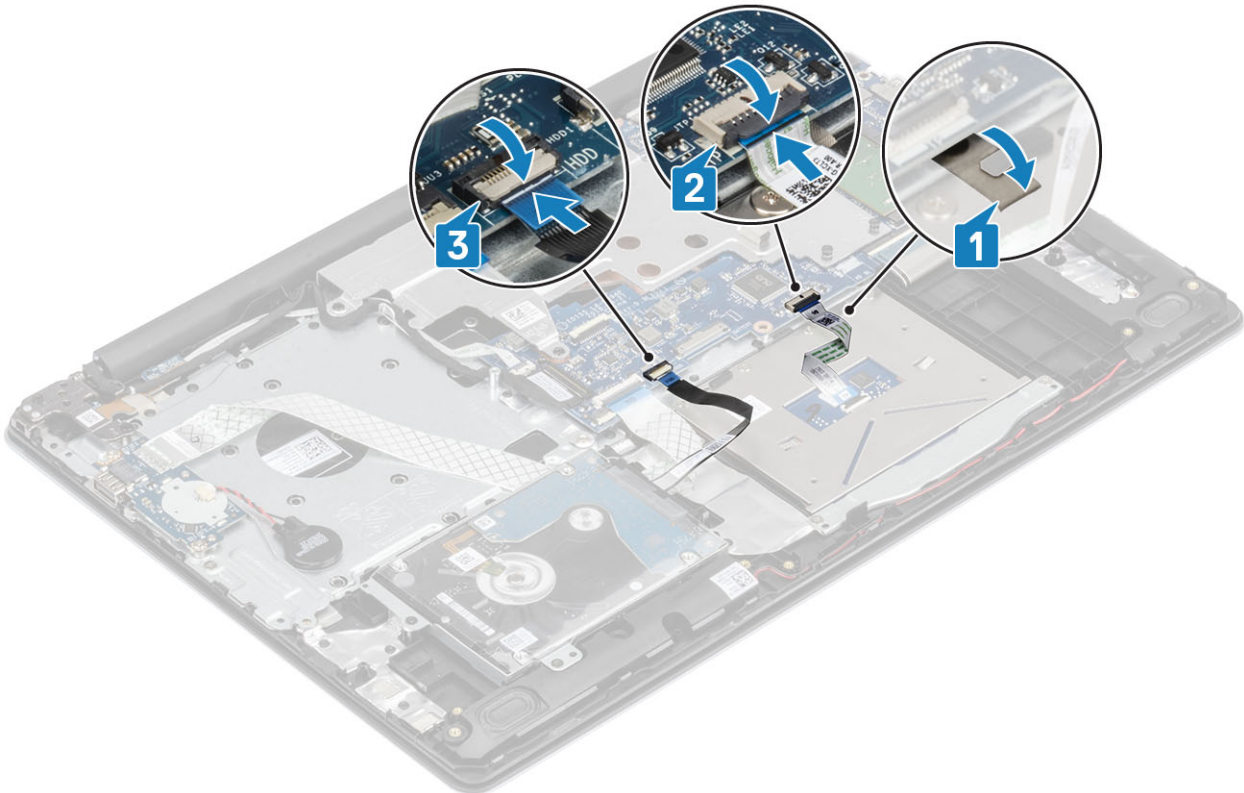

### Next steps

- 1 Install the [battery](#).
- 2 Install the [base cover](#).
- 3 Install the [SD card](#).
- 4 Follow the procedures in [After working inside your computer](#).

## Hard drive assembly

### Removing the hard drive assembly

#### Prerequisite

- 1 Follow the procedure in [Before working inside your computer](#).
- 2 Remove the [SD card](#).
- 3 Remove the [base cover](#).
- 4 Remove the [battery](#)

#### Steps

- 1 Lift the latch and disconnect the hard drive cable from the system board [1].
- 2 Remove the four screws (M2x3) that secure the hard drive assembly to the palm rest and keyboard assembly [2].
- 3 Lift the hard drive assembly along with its cable off the palm rest and keyboard assembly [3].

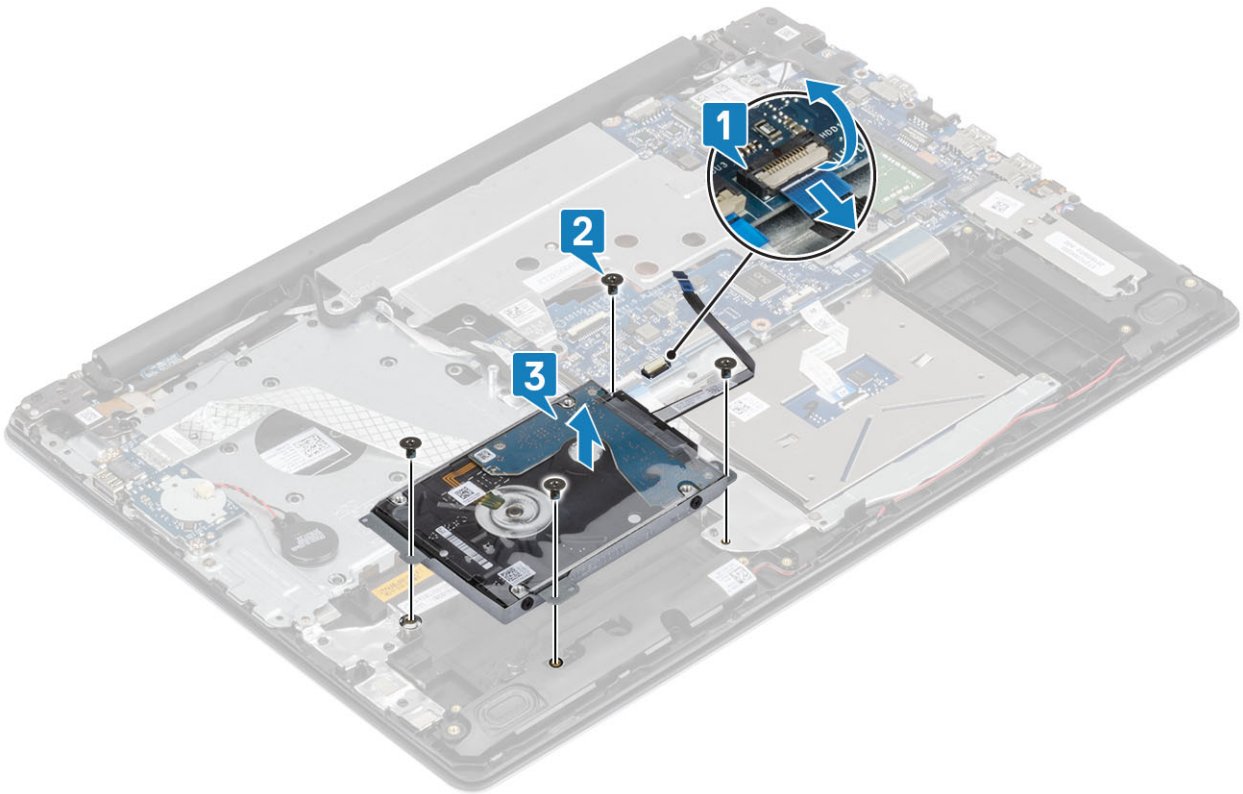

# Installing the hard drive assembly

## Steps

- 1 Align the screw holes on the hard drive assembly with the screw holes on the palm rest and keyboard assembly [1].
- 2 Replace the four screws (M2x3) that secure the hard drive assembly to the palm rest and keyboard assembly [2].
- 3 Connect the hard drive cable to the system board and close the latch to secure the cable [3].

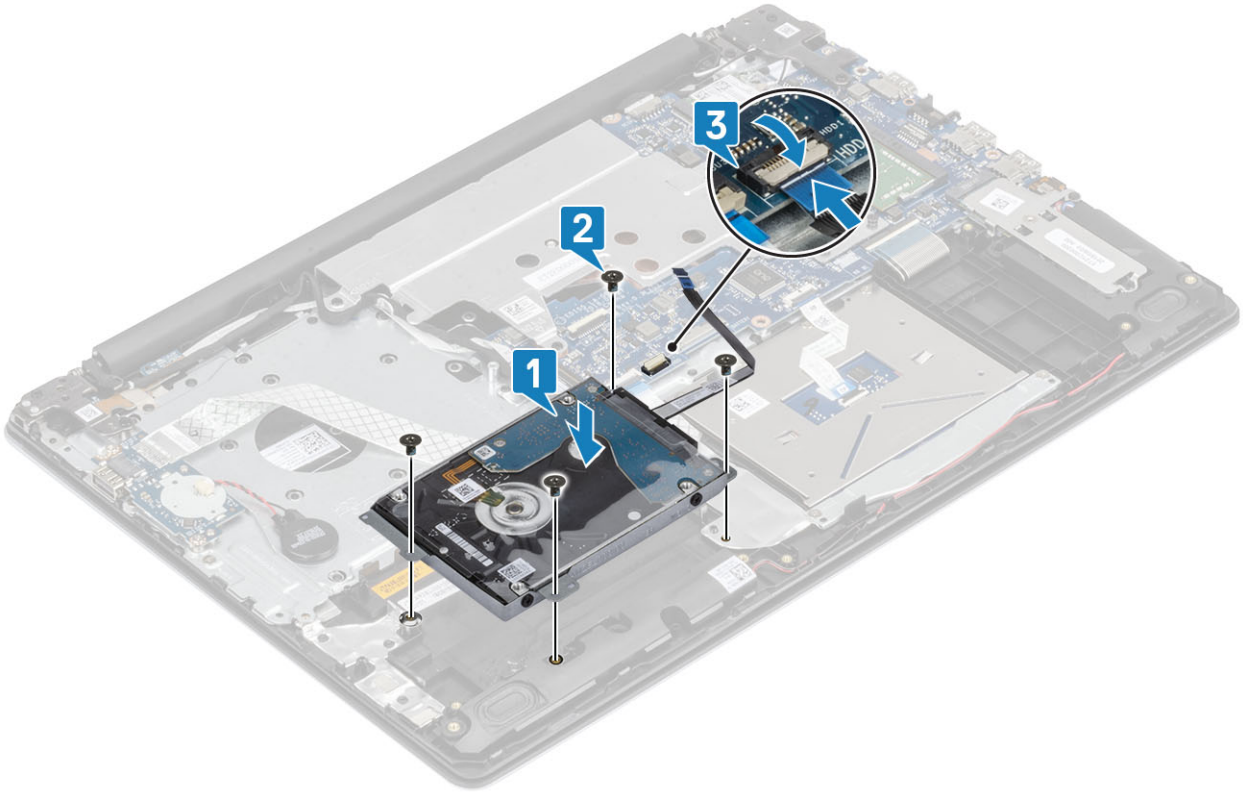

## Next steps

- 1 Install the [battery](#).
- 2 Install the [base cover](#).
- 3 Install the [SD card](#).
- 4 Follow the procedures in [After working inside your computer](#).

# Hard drive

## Removing the hard drive

### Prerequisite

- 1 Follow the procedure in [Before working inside your computer](#).
- 2 Remove the [SD card](#).
- 3 Remove the [base cover](#).
- 4 Remove the [battery](#)
- 5 Remove the [hard drive assembly](#)

## Steps

- 1 Disconnect the interposer from the hard drive assembly.



- 2 Remove the four screws (M3x3) that secure the hard drive bracket to the hard drive [1].
- 3 Lift the hard drive bracket off the hard drive [2].

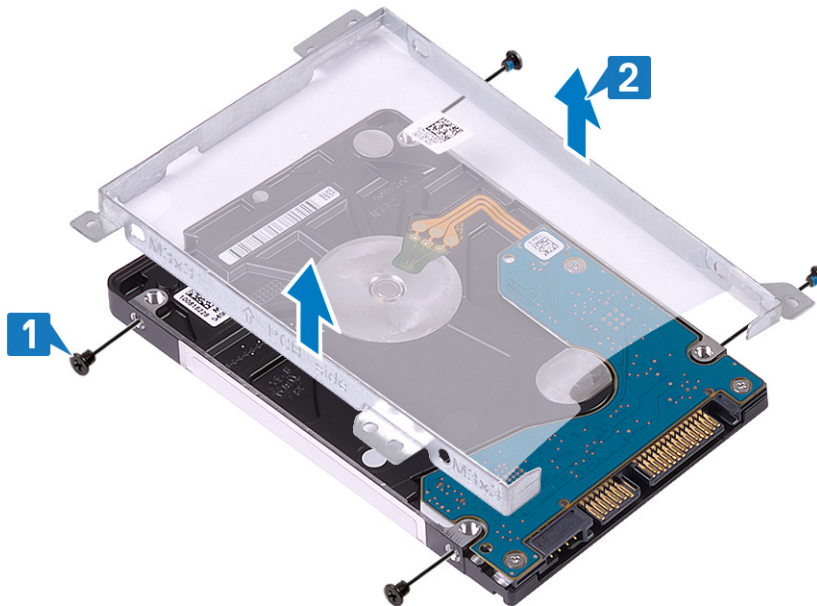

## Installing the hard drive

### Steps

- 1 Align the screw holes on the hard drive bracket with the screw holes on the hard drive [1].
- 2 Replace the four screws (M3x3) that secure the hard drive bracket to the hard drive [2].

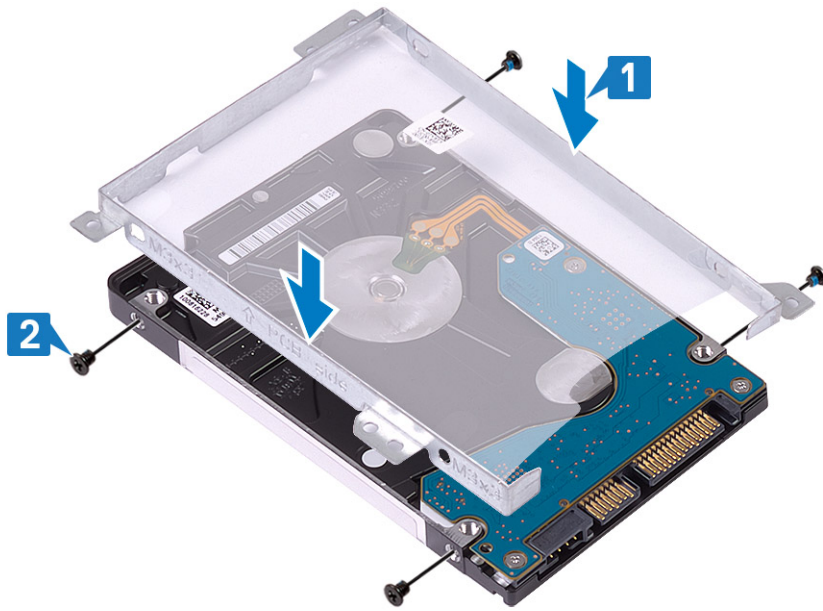

- 3 Connect the interposer to the hard drive assembly.



### Next steps

- 1 Install the [hard drive assembly](#).
- 2 Install the [battery](#).
- 3 Install the [base cover](#).
- 4 Install the [SD card](#).
- 5 Follow the procedures in [After working inside your computer](#).

## WLAN card

### Removing the WLAN card

#### Prerequisite

- 1 Follow the procedure in [Before working inside your computer](#).
- 2 Remove the [SD card](#).

- 3 Remove the [base cover](#).
- 4 Remove the [battery](#)

### Steps

- 1 Remove the M2x3 screw that secures the WLAN bracket to the system [1].
- 2 Lift the WLAN bracket from the system [2].
- 3 Disconnect the WLAN antenna cables from the connectors on the WLAN card [3].
- 4 Pull the WLAN card from the connector on the system board [4].



## Installing the WLAN card

### About this task

**⚠ CAUTION:** To avoid damage to the WLAN card, do not place any cables under it.

### Steps

- 1 Insert the WLAN card into the connector on the system board [1].
- 2 Connect the WLAN cables to the connectors on the WLAN card [2].
- 3 Place the WLAN card bracket to secure the WLAN cables [3].
- 4 Replace the M2x3 screw to secure the WLAN bracket to the WLAN card [4].

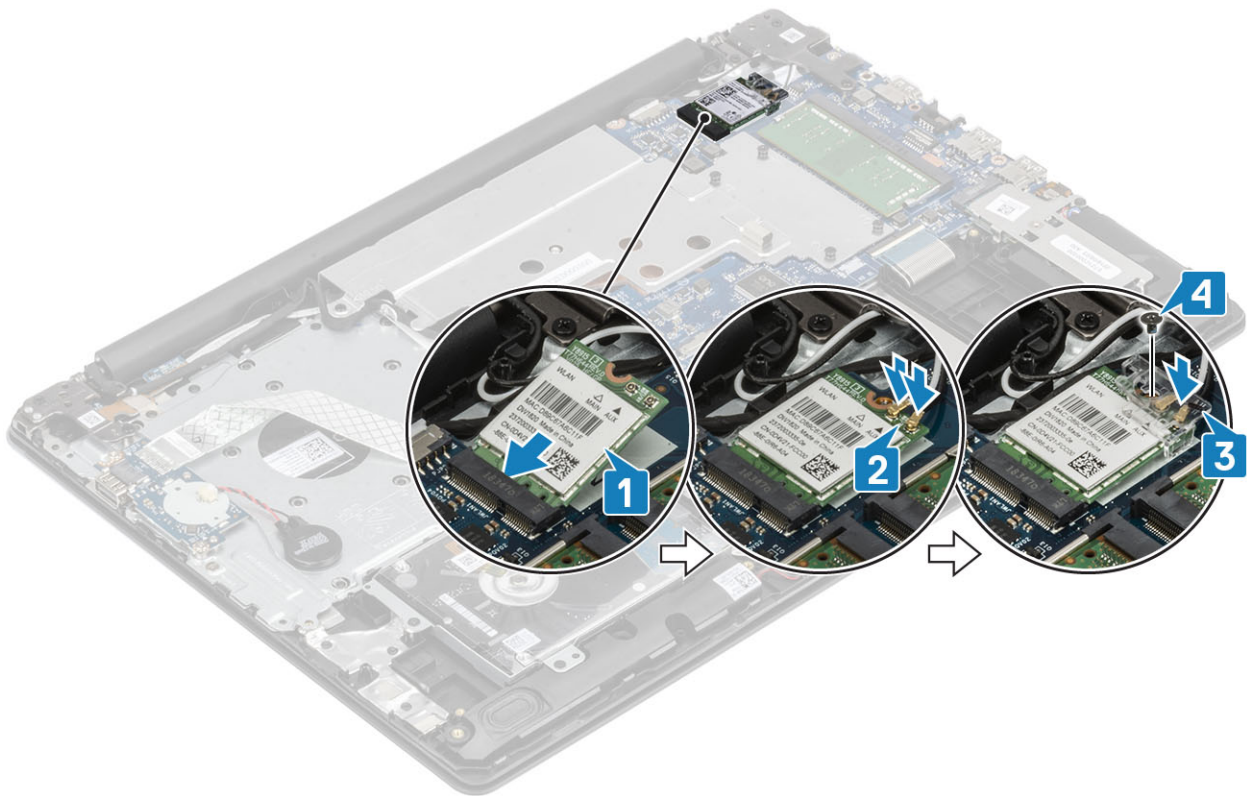

### Next steps

- 1 Install the [battery](#).
- 2 Install the [base cover](#).
- 3 Install the [SD card](#).
- 4 Follow the procedures in [After working inside your computer](#).

## Coin-cell battery

### Removing the coin-cell battery

#### Prerequisites

**⚠ CAUTION:** Removing the coin-cell battery resets the BIOS setup program's settings to default. Before removing the coin-cell battery, it is recommended to note the BIOS setup program's settings.

- 1 Follow the procedure in [Before working inside your computer](#)
- 2 Remove the [base cover](#).
- 3 Remove the [battery](#).

#### Steps

- 1 Disconnect the coin-cell battery cable from the I/O board [1].
- 2 Peel the coin-cell battery cable from the palm rest and keyboard assembly [2].

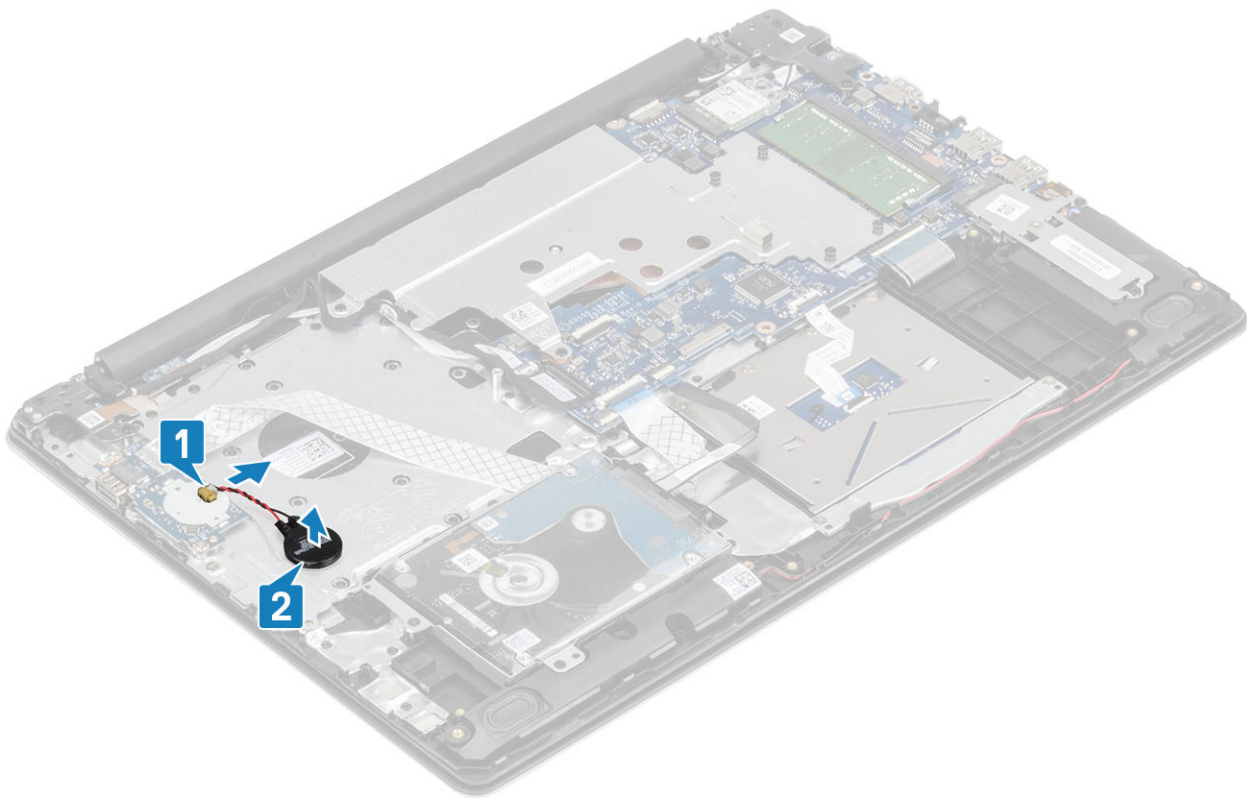

## Installing the coin-cell battery

### Steps

- 1 Affix the coin cell battery on the palm rest and keyboard assembly [1].
- 2 Connect the coin-cell battery cable to the connector on the IO board [2].

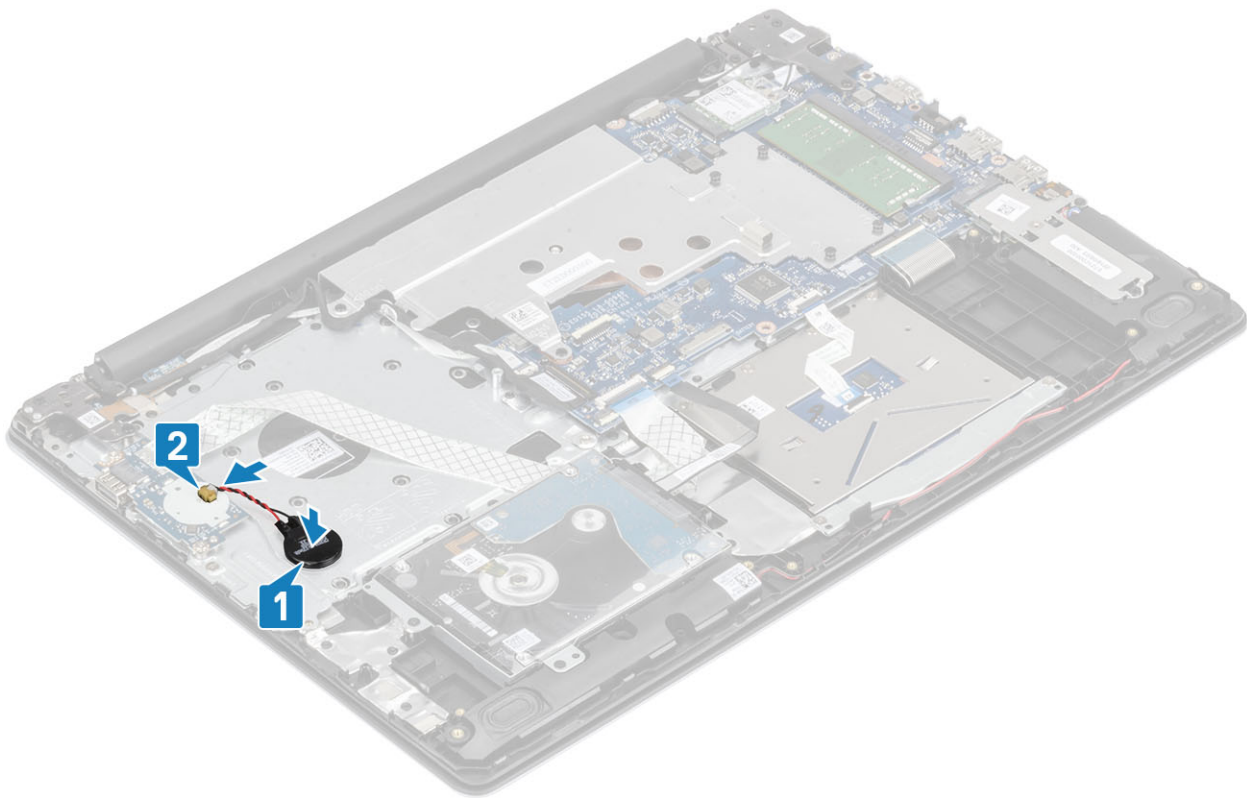

#### Next steps

- 1 Install the [battery](#).
- 2 Install the [base cover](#).
- 3 Install the [SD card](#).
- 4 Follow the procedures in [After working inside your computer](#).

## Thermal plate

### Removing the thermal plate

#### Prerequisite

- 1 Follow the procedure in [Before working inside your computer](#).
- 2 Remove the [SD card](#).
- 3 Remove the [base cover](#).
- 4 Remove the [battery](#)

#### Steps

- 1 Open the latch and disconnect the display cable from the connector on the system board [1].
- 2 Unroute the display cable from the routing clips on the system [2].

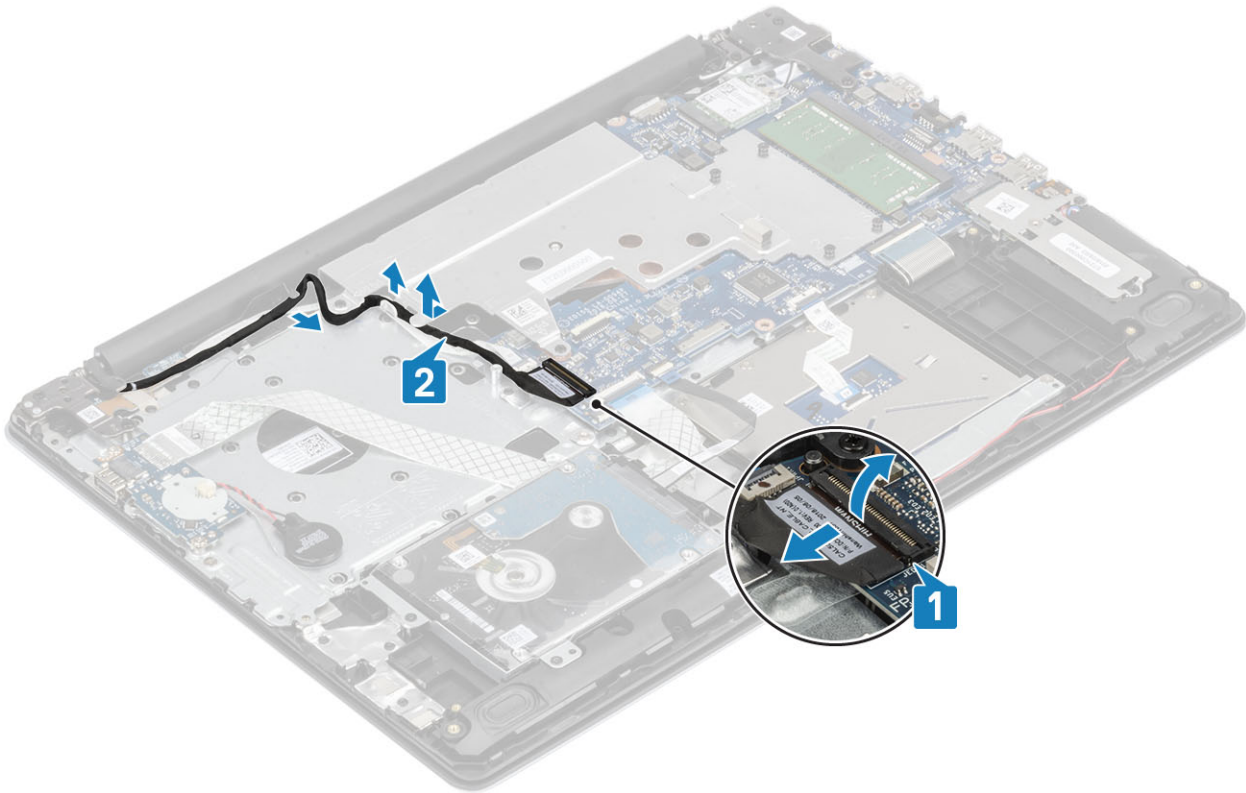

- 3 Remove the two (M2.5x5) screws that secure the thermal plate to the chassis [1].
- 4 Loosen the four captive screws that secure the thermal plate to the chassis in a sequential order (1,2,3,4) as shown on the thermal plate [2].
- 5 Lift the thermal plate from the system board [3].

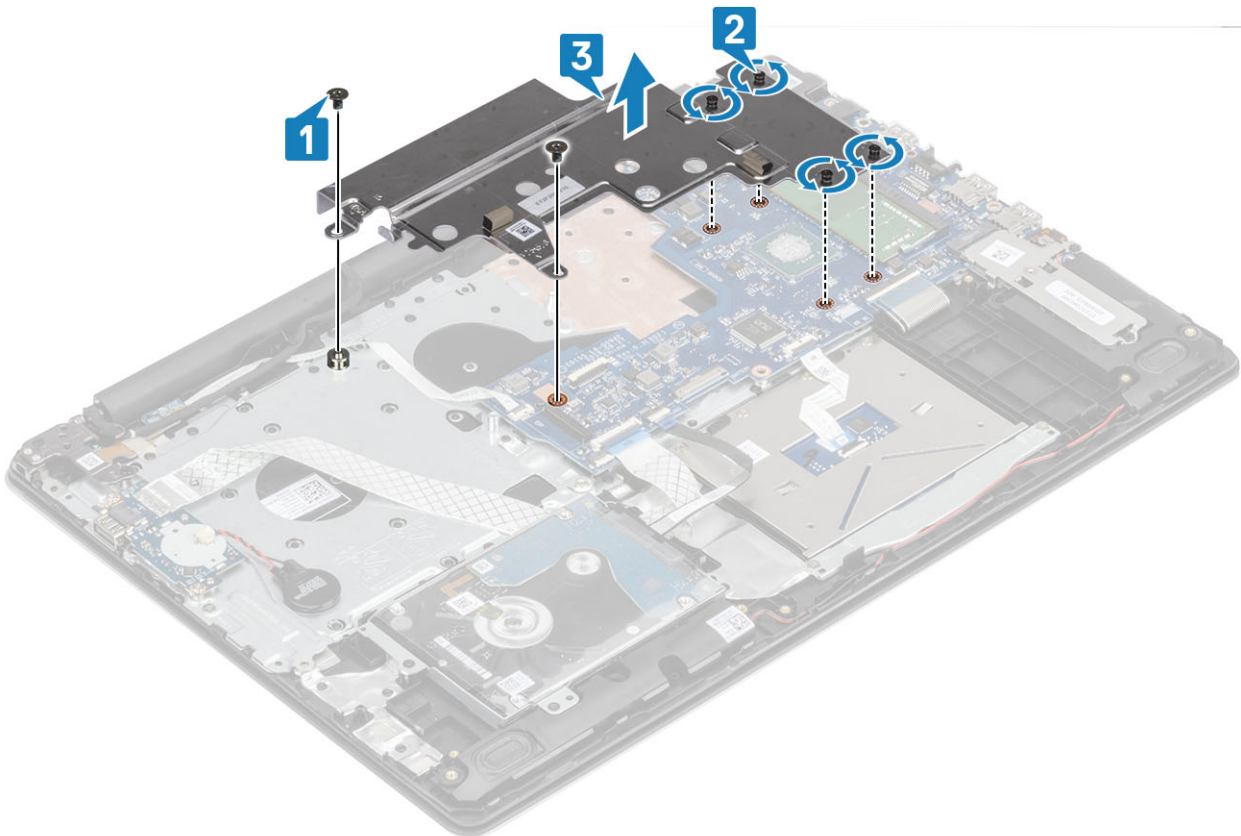

# Installing the thermal plate

## Steps

- 1 Place the thermal plate on the system board and align the screw holes on the thermal plate with the screw holes on the system board [1].
- 2 Tighten the captive screws in a sequential order (1,2,3,4) as indicated on the heat sink to secure the thermal plate to the system board [2].
- 3 Replace the two (M2x3) screws that secure the thermal plate to the system board [3].

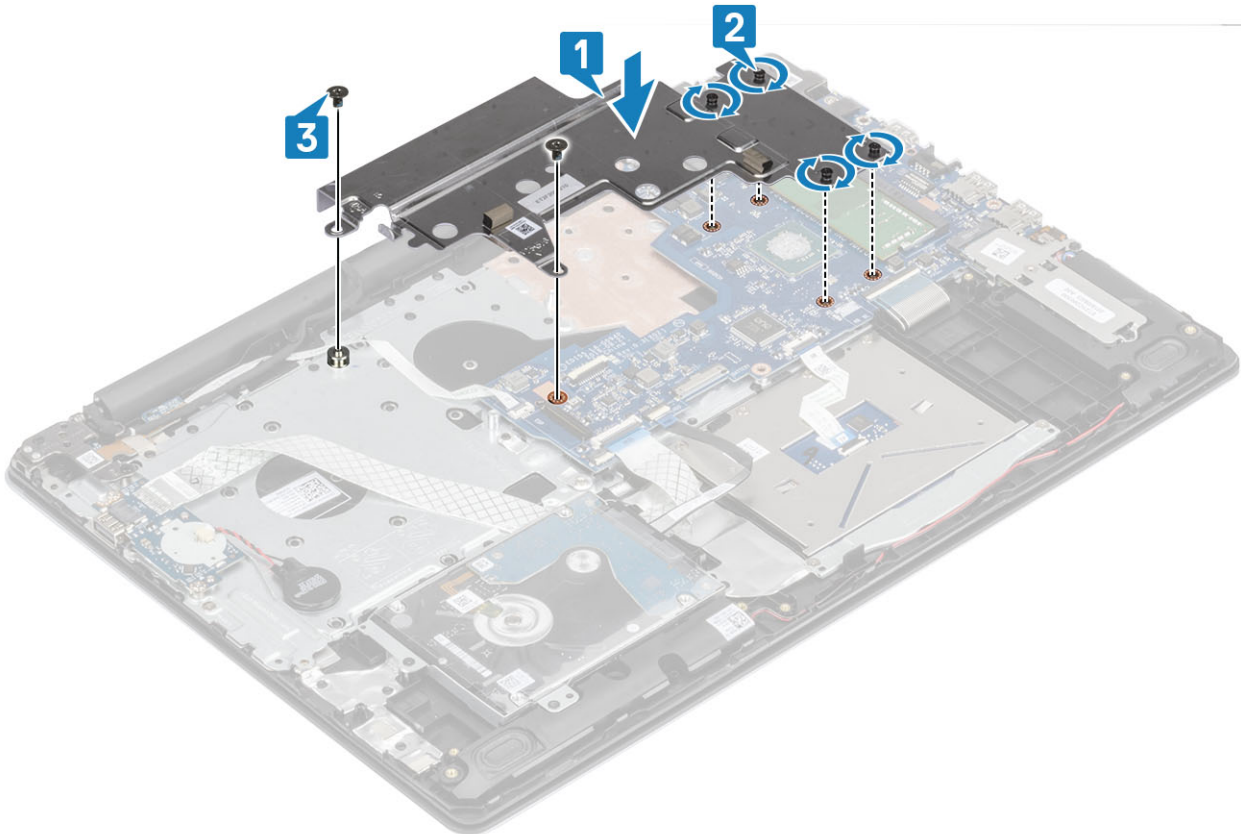

- 4 Route the display cable through the routing clips [1] and connect it to the connector on the system board [2].

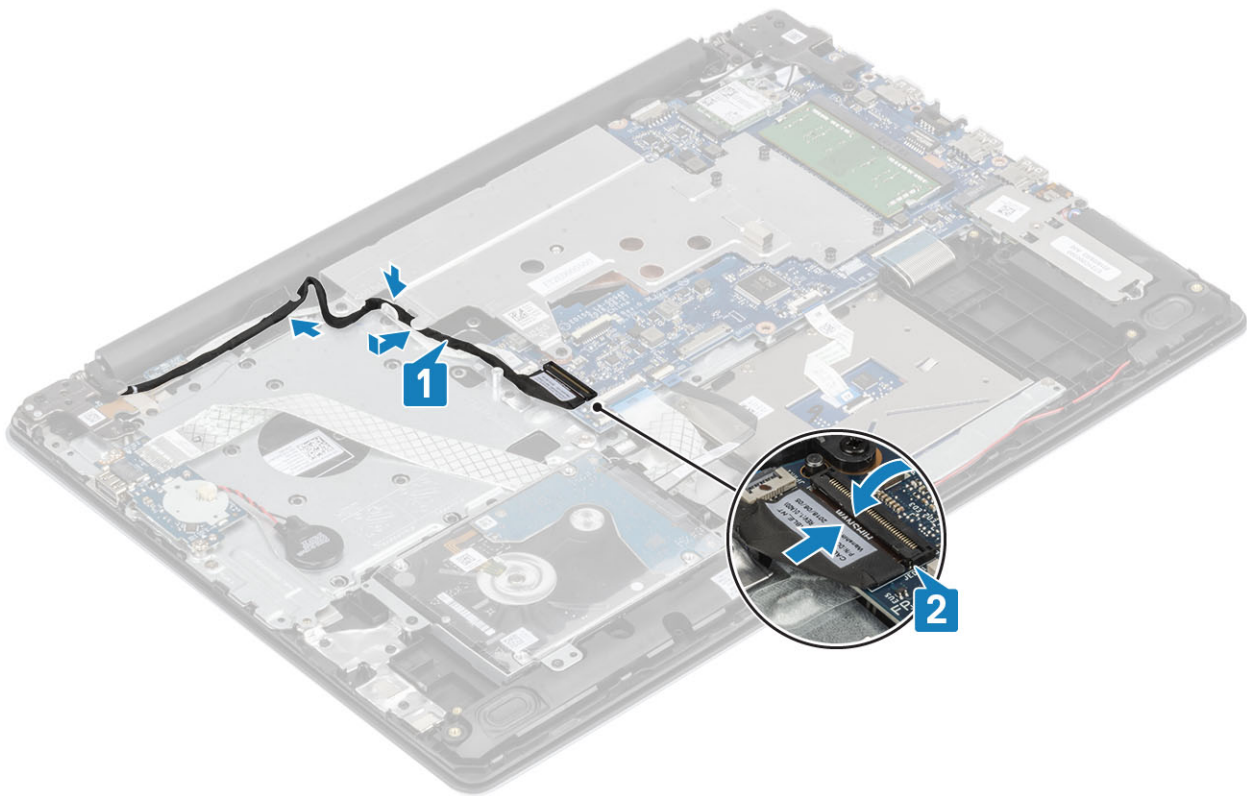

### Next steps

- 1 Install the [battery](#).
- 2 Install the [base cover](#).
- 3 Install the [SD card](#).
- 4 Follow the procedures in [After working inside your computer](#).

## Speaker

### Removing the speakers

#### Prerequisite

- 1 Follow the procedure in [Before working inside your computer](#).
- 2 Remove the [SD card](#).
- 3 Remove the [base cover](#).
- 4 Remove the [battery](#)
- 5 Remove the [M.2 SSD card](#)

#### Steps

- 1 Disconnect the speaker cable from the system board [1].
- 2 Note the speaker cable routing and remove it from the routing guides on palm rest and key board assembly [2].
- 3 Lift the speakers, along with the cable, off the palm rest and keyboard assembly [3].

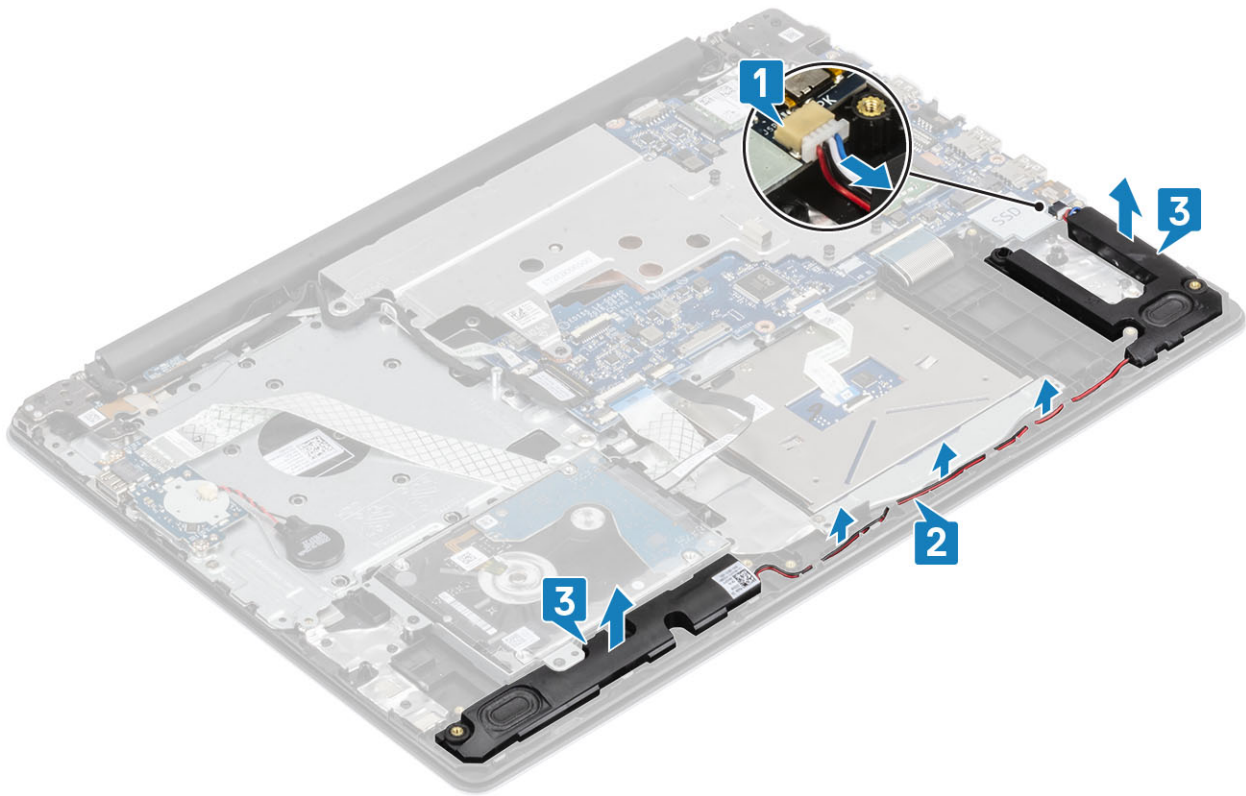

## Installing the speakers

### About this task

**NOTE:** If the rubber grommets are pushed out when removing the speakers, push them back in before replacing the speakers.

### Steps

- 1 Using the alignment posts and rubber grommets, place the speakers in the slots on the palm rest and keyboard assembly [1].
- 2 Route the speaker cable through the routing guides on the palm rest and keyboard assembly [2].
- 3 Connect the speaker cable to the system board [3].

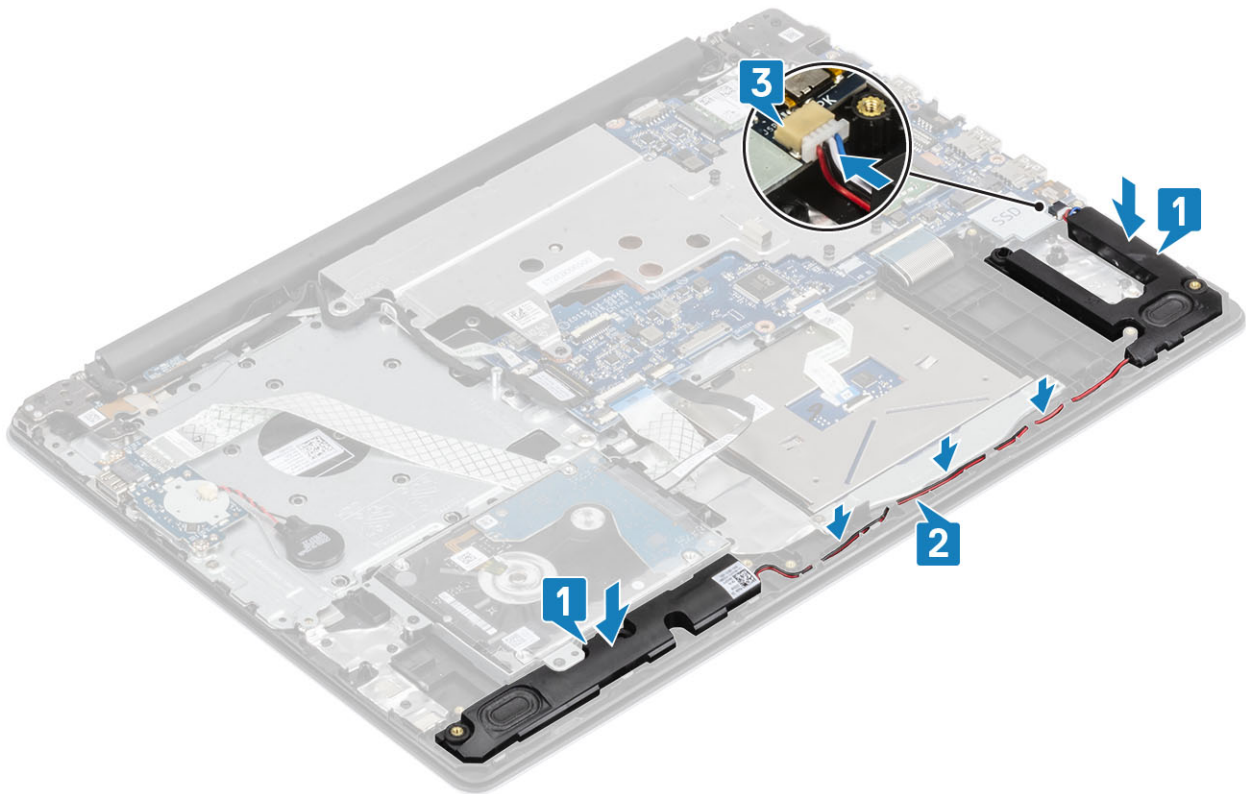

### Next steps

- 1 Install the [M.2 SSD card](#).
- 2 Install the [battery](#).
- 3 Install the [base cover](#).
- 4 Install the [SD card](#).
- 5 Follow the procedures in [After working inside your computer](#).

## Display assembly

### Removing the display assembly

#### Prerequisite

- 1 Follow the procedure in [Before working inside your computer](#).
- 2 Remove the [SD card](#).
- 3 Remove the [base cover](#).
- 4 Remove the [battery](#).
- 5 Remove the [WLAN card](#).

#### Steps

- 1 Open the latch and disconnect the display cable from the system board [1].
- 2 Unroute the display cable from the routing channel on the system [2].
- 3 Unroute the wireless cables from the routing clips [3].

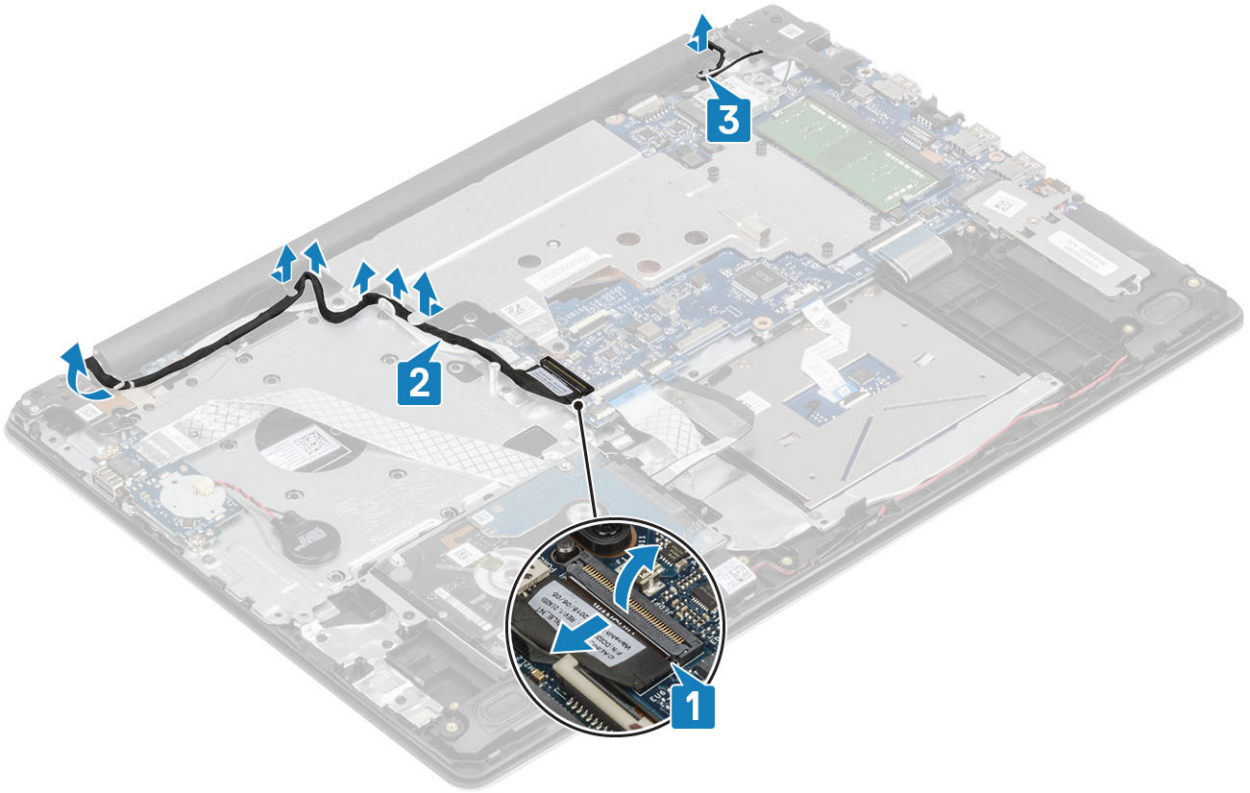

- 4 Remove the five screws (M2.5x5) that secure the left and right hinges [1].
- 5 Slightly lift the palmrest assembly [2]

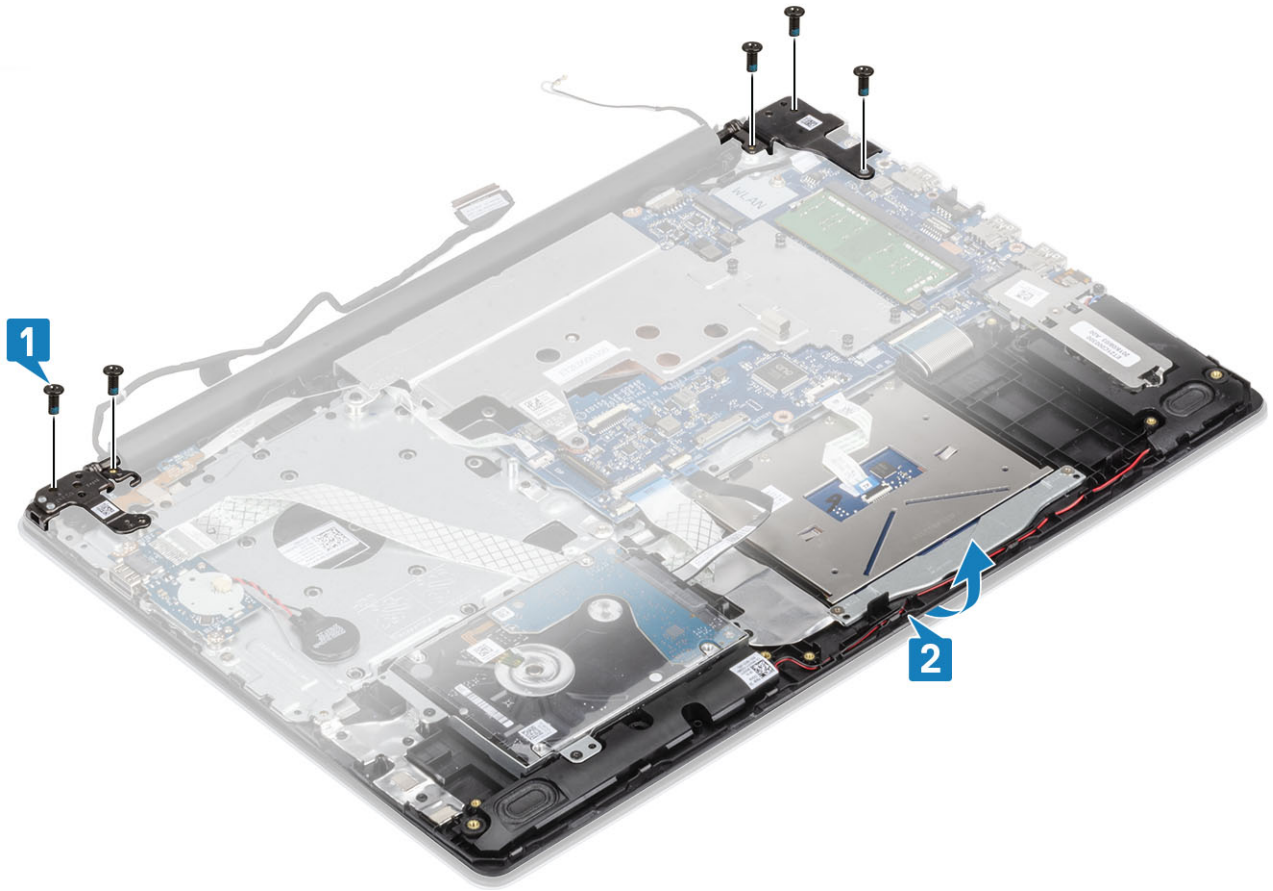

- 6 Lift the hinges [1] and pull the display assembly to remove the display assembly from the system [2]

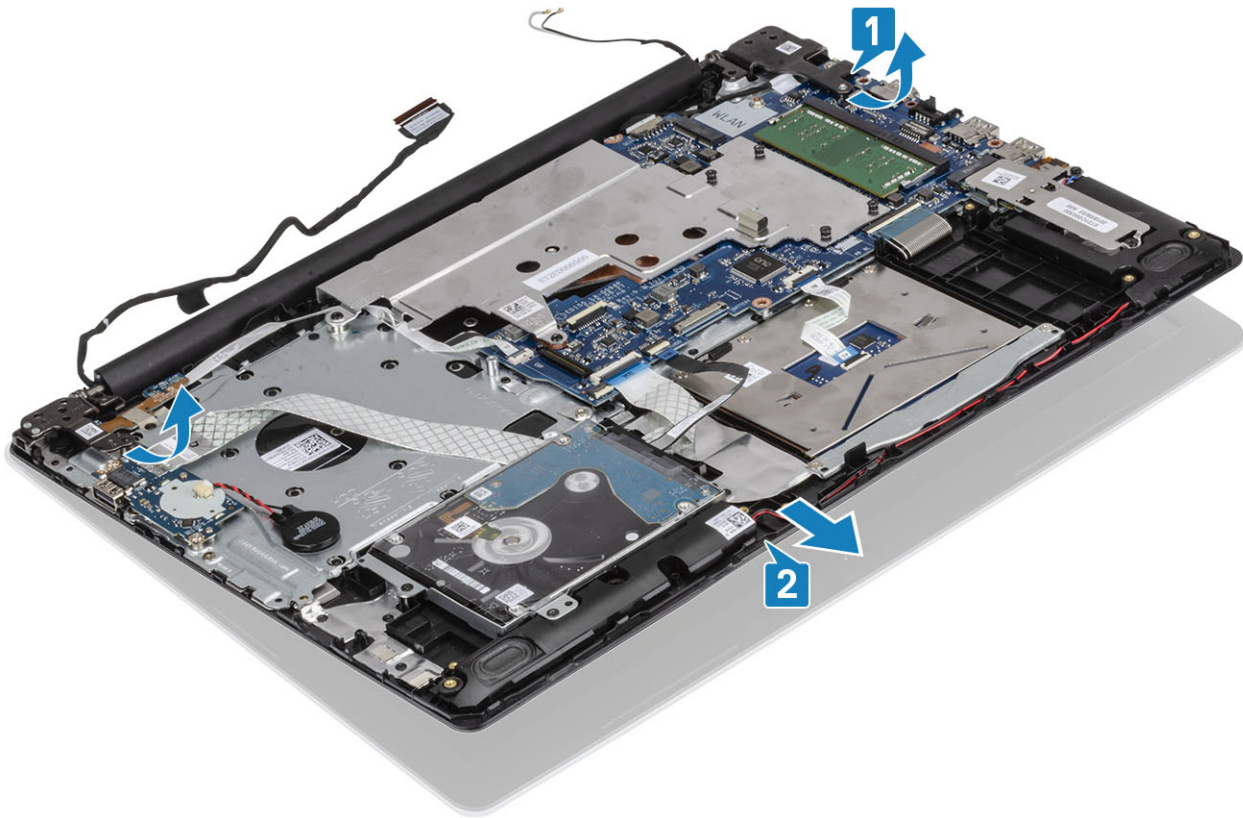

## Installing the display assembly

### Steps

- 1 Slide the palm rest and keyboard assembly at an angle [1].
- 2 Close the palm rest and keyboard assembly [2].
- 3 Using the alignment posts, press the hinges down on the system board and the palm rest and keyboard assembly [3].

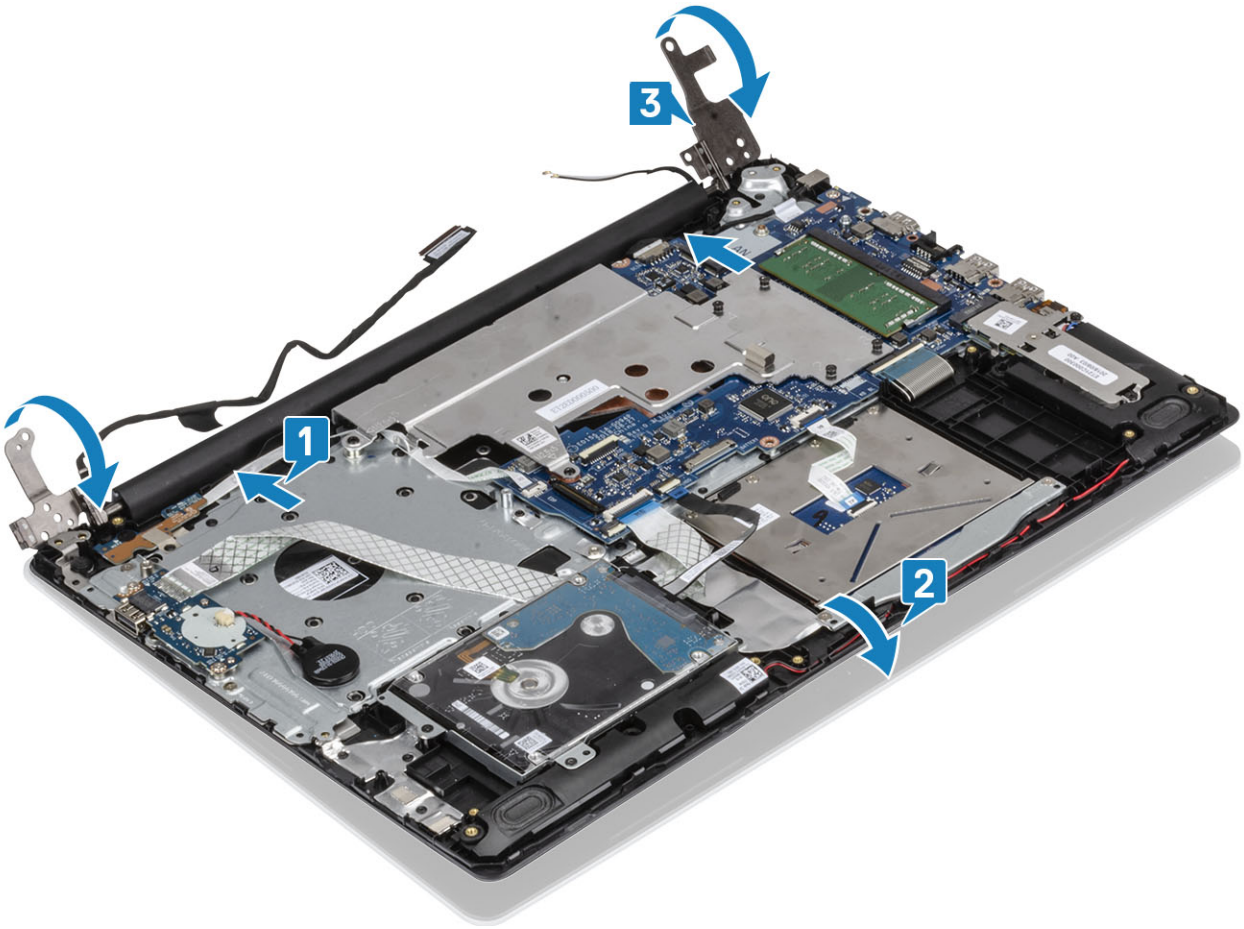

- 4 Replace the five screws (M2.5x5) that secure the left and right hinges to the system board and palm rest and keyboard assembly.

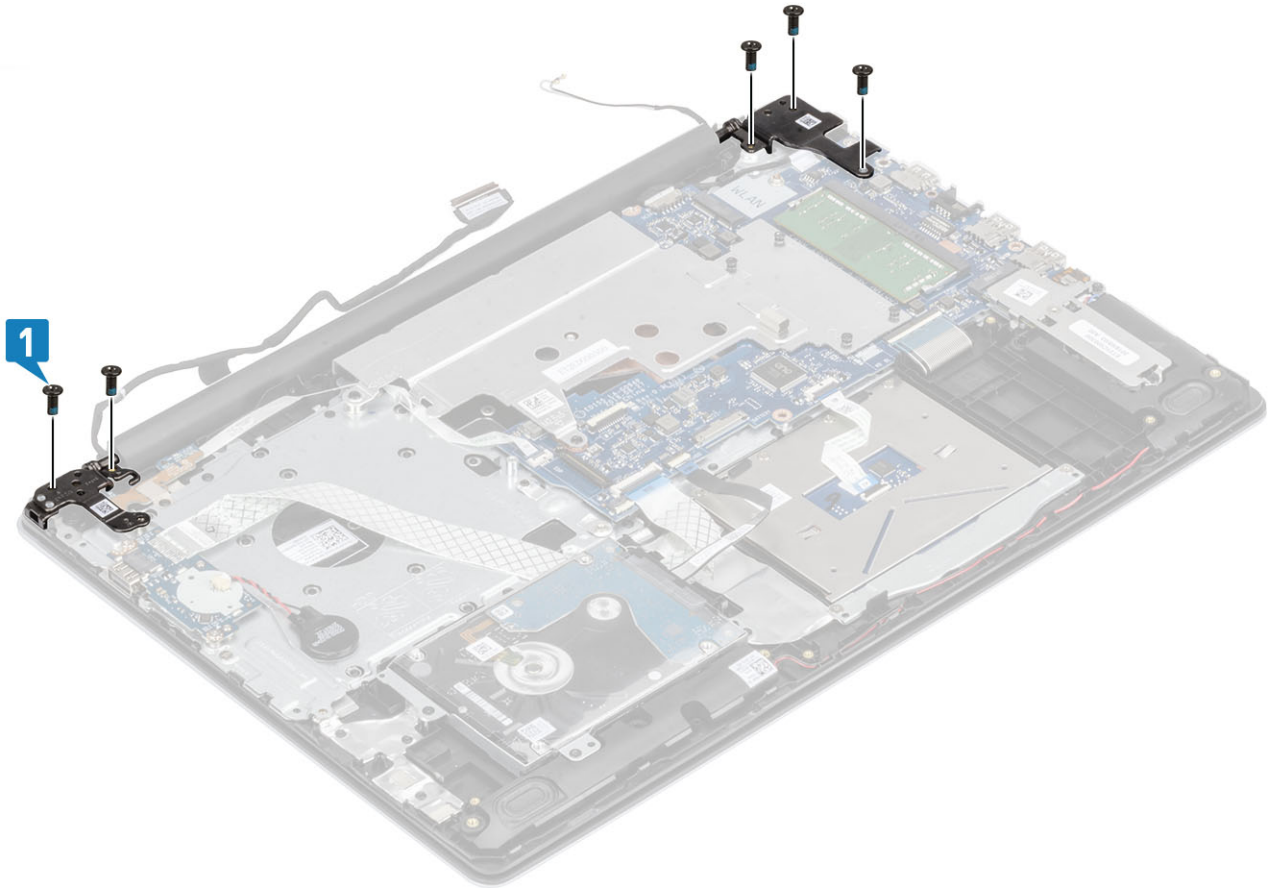

- 5 Route the display cable through the routing clips [1].
- 6 Connect the display cable to the system board [2].
- 7 Route the wireless cable through the routing clips [3].

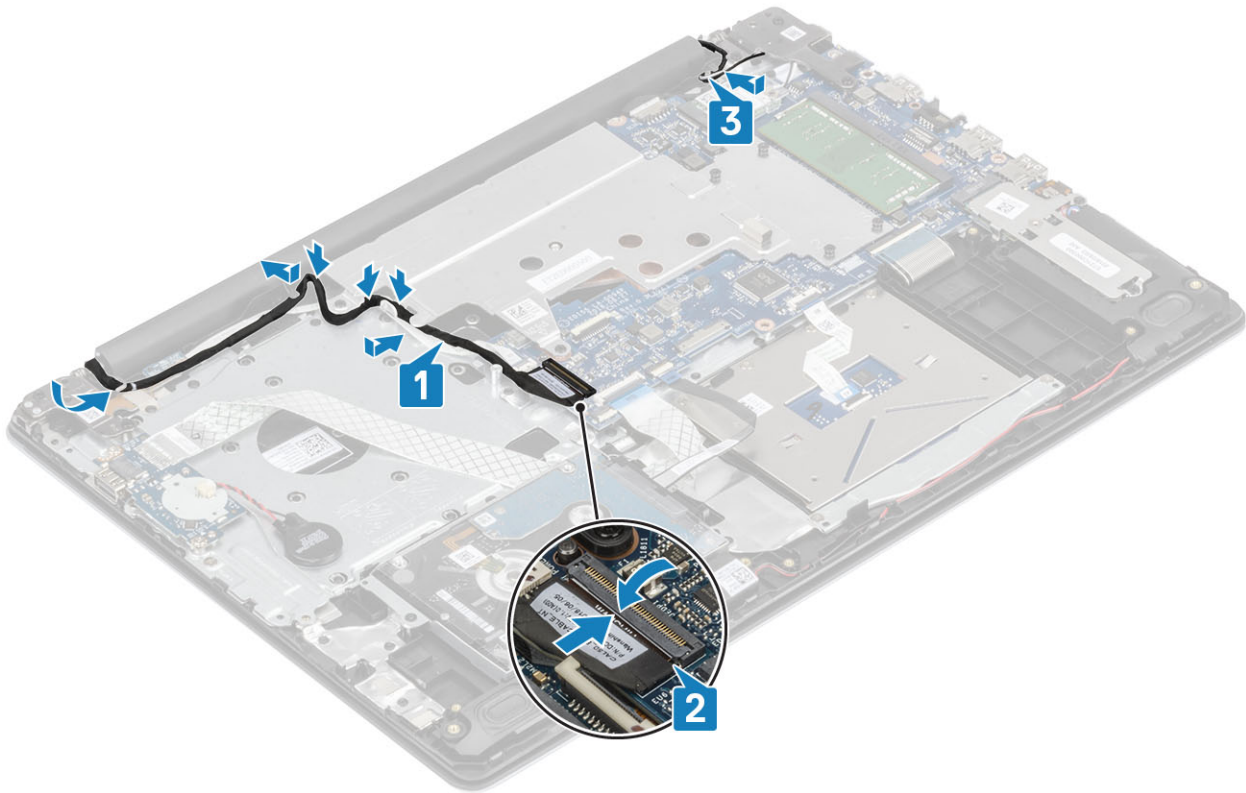

### Next steps

- 1 Install the [display assembly](#).
- 2 Install the [thermal pad](#).
- 3 Install the [WLAN card](#).
- 4 Install the [battery](#).
- 5 Install the [base cover](#).
- 6 Install the [SD card](#).
- 7 Follow the procedures in [After working inside your computer](#).

## System board

### Removing the system board

#### Prerequisites

- 1 Follow the procedure in [Before working inside your computer](#).
- 2 Remove the [SD card](#).
- 3 Remove the [base cover](#).
- 4 Remove the [battery](#)
- 5 Remove the [WLAN card](#)
- 6 Remove the [thermal plate](#)
- 7 Remove the [display assembly](#)

#### Steps

- 1 Disconnect the power-adaptor port cable from the system board [1].
- 2 Disconnect the speaker cable from the system board [2].

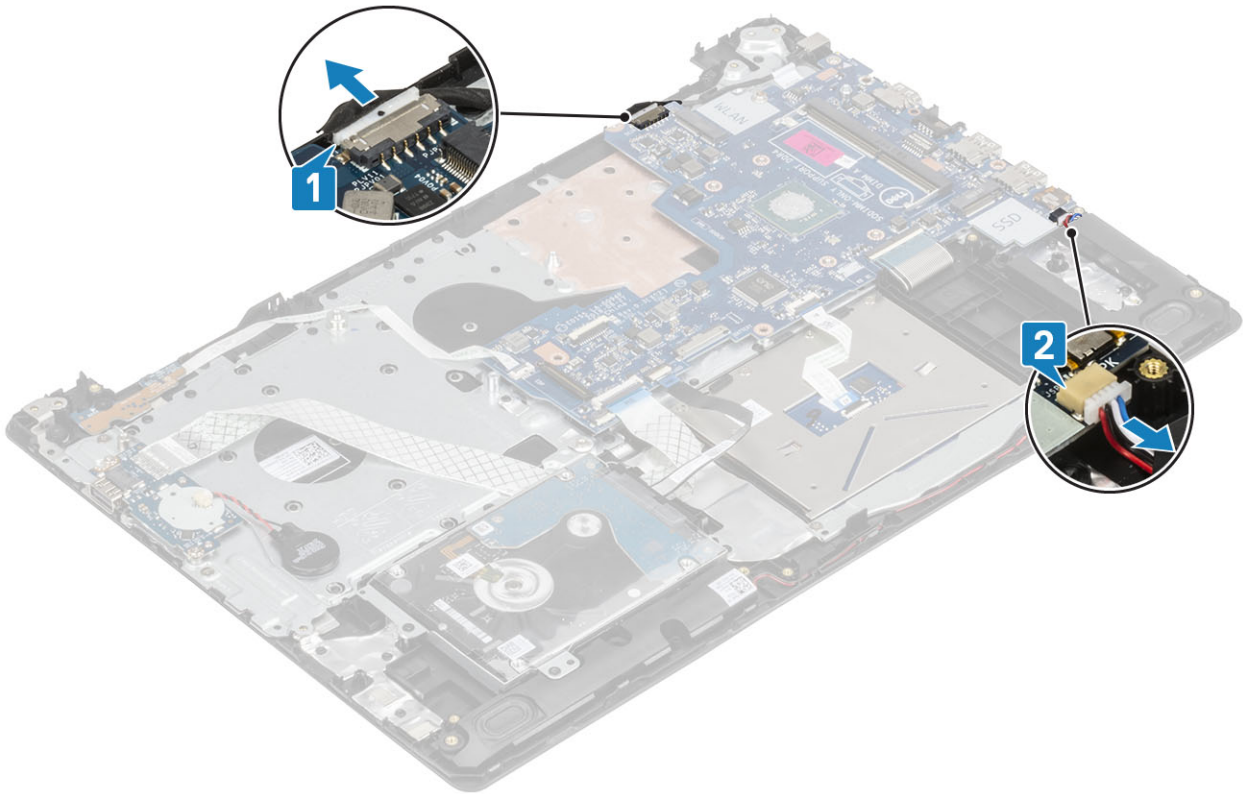

- 3 Open the latch and disconnect the power button board cable from the connector on the system board [1].
- 4 Open the latch and disconnect the finger-print reader cable from the connector on the system board [2].
- 5 Open the latch and disconnect the I/O board cable from the connector on the system board [3].
- 6 Open the latch and disconnect the hard-drive cable from the connector on the system board [4].
- 7 Open the latch and disconnect the touch pad cable from the connector on the system board [5].
- 8 Open the latch and disconnect the keyboard cable from the connector on the system board [6].

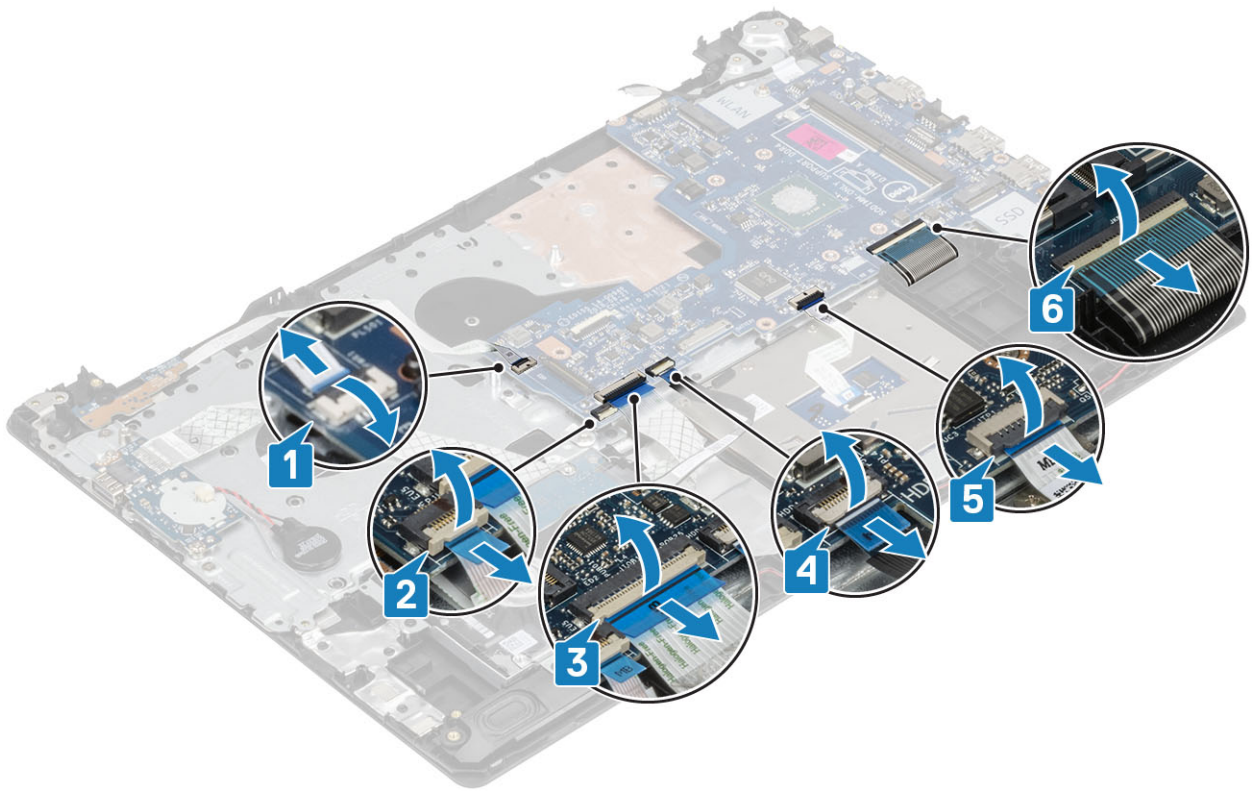

- 9 Remove the screw (M2x4) that secures the system board to palm rest and keyboard assembly.
- 10 Lift the system board off the palm rest and keyboard assembly.

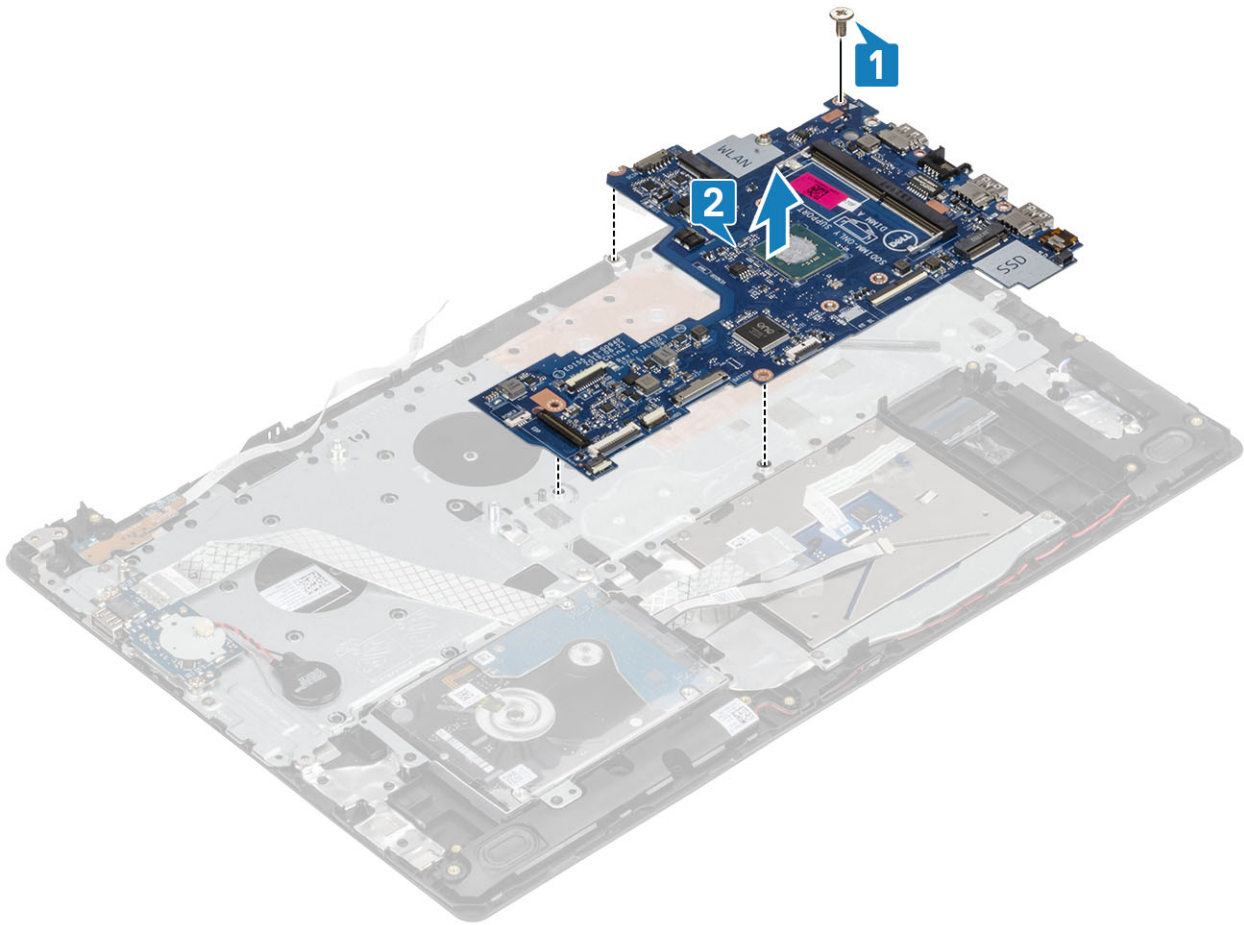

## Installing the system board

### Steps

- 1 Align the screw hole on the system board with the screw hole on the palm rest and keyboard assembly [1].
- 2 Replace the screw (M2x4) that secures the system board to the palm rest and keyboard assembly [2].

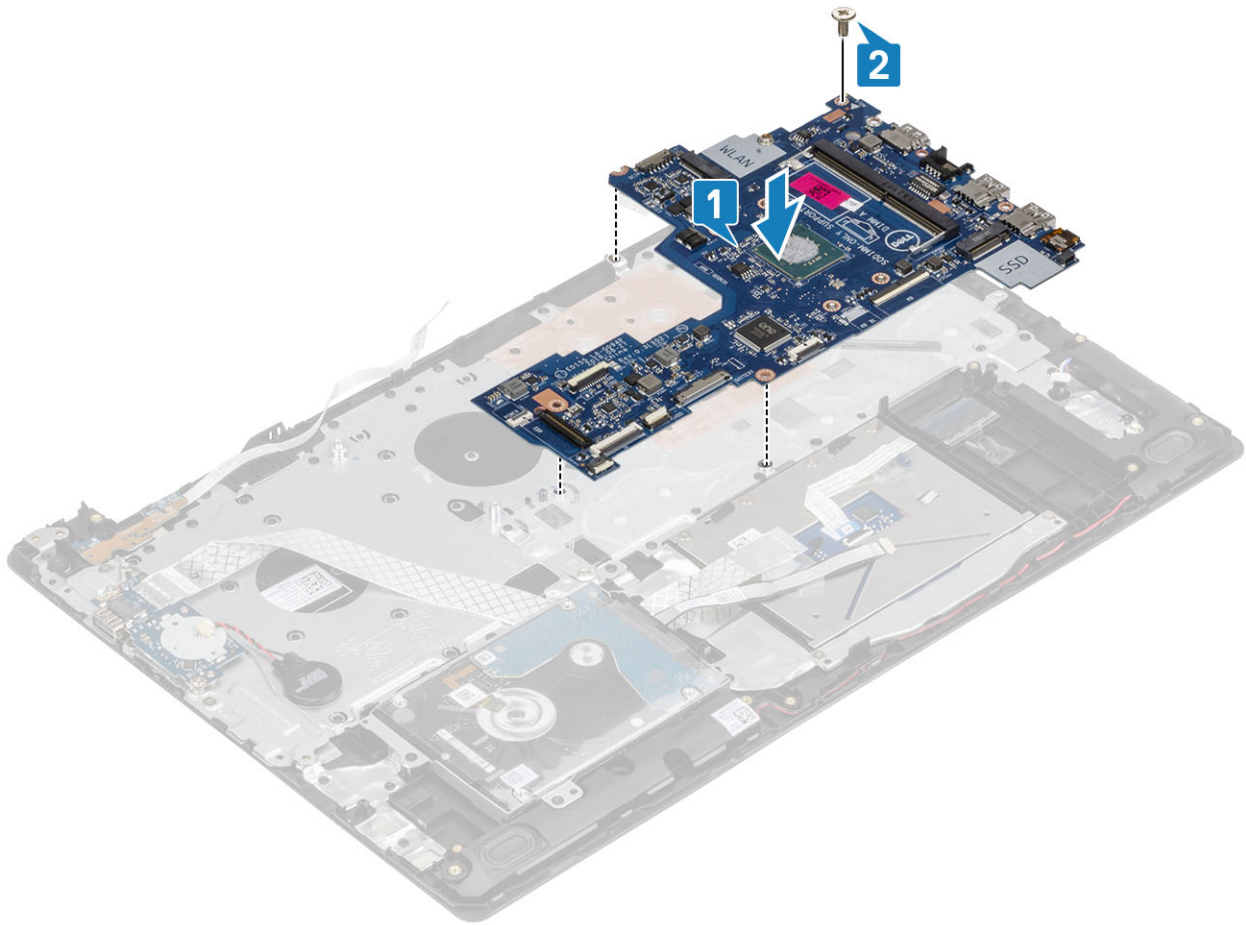

- 3 Connect the power button board cable from the connector on the system board [1].
- 4 Connect the finger-print reader cable from the connector on the system board [2].
- 5 Connect the I/O board cable from the connector on the system board [3].
- 6 Connect the hard-drive cable from the connector on the system board [4].
- 7 Connect the touch pad cable from the connector on the system board [5].
- 8 Connect the keyboard cable from the connector on the system board [6].

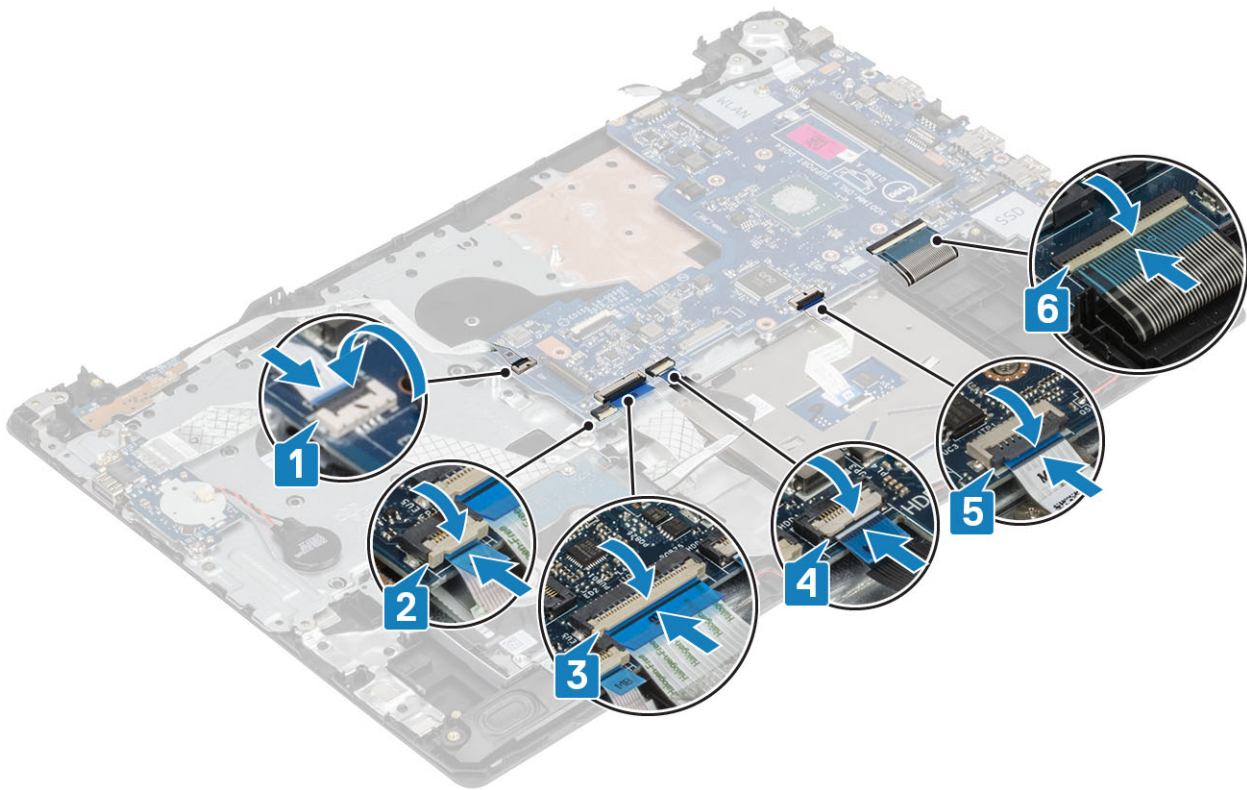

- 9 Connect the power-adaptor port cable from the system board [1].
- 10 Connect the speaker cable from the system board [2].

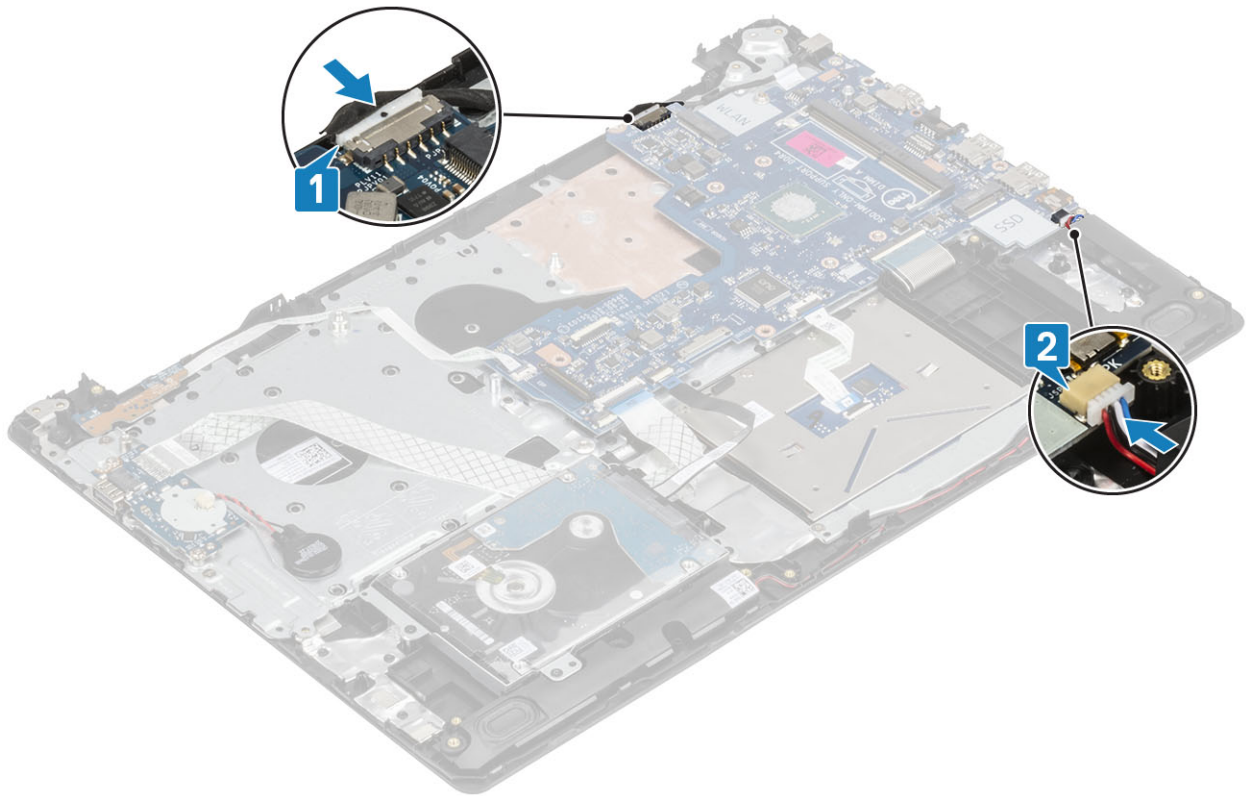

**Next steps**

- 1 Install the [display assembly](#).

- 2 Install the [thermal pad](#).
- 3 Install the [WLAN card](#).
- 4 Install the [battery](#).
- 5 Install the [base cover](#).
- 6 Install the [SD card](#).
- 7 Follow the procedures in [After working inside your computer](#).

## Display bezel

### Removing the display bezel

#### Prerequisites

- 1 Follow the procedure in [Before working inside your computer](#).
- 2 Remove the [SD card](#).
- 3 Remove the [base cover](#).
- 4 Remove the [battery](#)
- 5 Remove the [WLAN card](#)
- 6 Remove the [thermal plate](#)
- 7 Remove the [display assembly](#)

#### Steps

- 1 Pry the inner top side of the display bezel [1].
- 2 Continue to pry the inner left and inner right edges of the display bezel [2].
- 3 Pry up the bottom inner edge of the display bezel and lift the bezel off the display assembly [3].

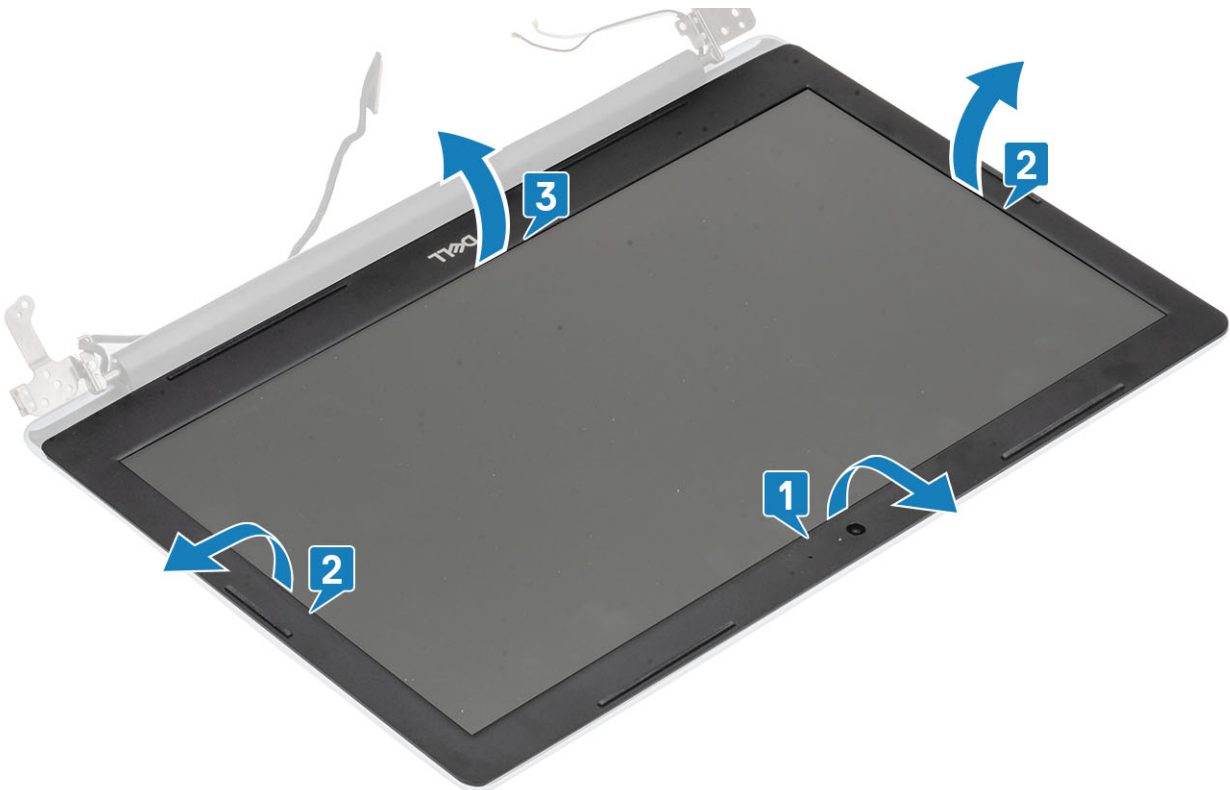

# Installing the display bezel

## Step

Align the display bezel with the display back-cover and antenna assembly, and then gently snap the display bezel into place [1].



## Next steps

- 1 Install the [display assembly](#).
- 2 Install the [WLAN card](#).
- 3 Install the [battery](#).
- 4 Install the [base cover](#).
- 5 Install the [SD card](#).
- 6 Follow the procedures in [After working inside your computer](#).

# Camera

## Removing the camera

### Prerequisites

- 1 Follow the procedure in [Before working inside your computer](#).
- 2 Remove the [SD card](#).
- 3 Remove the [base cover](#).
- 4 Remove the [battery](#)
- 5 Remove the [WLAN card](#)
- 6 Remove the [thermal plate](#)

- 7 Remove the [display assembly](#)
- 8 Remove the [display bezel](#)

### Steps

- 1 Using a plastic scribe, gently pry the camera off the display back-cover and antenna assembly [1].
- 2 Disconnect the camera cable from the camera module [2].
- 3 Lift the camera module from the display back-cover and antenna assembly [3].

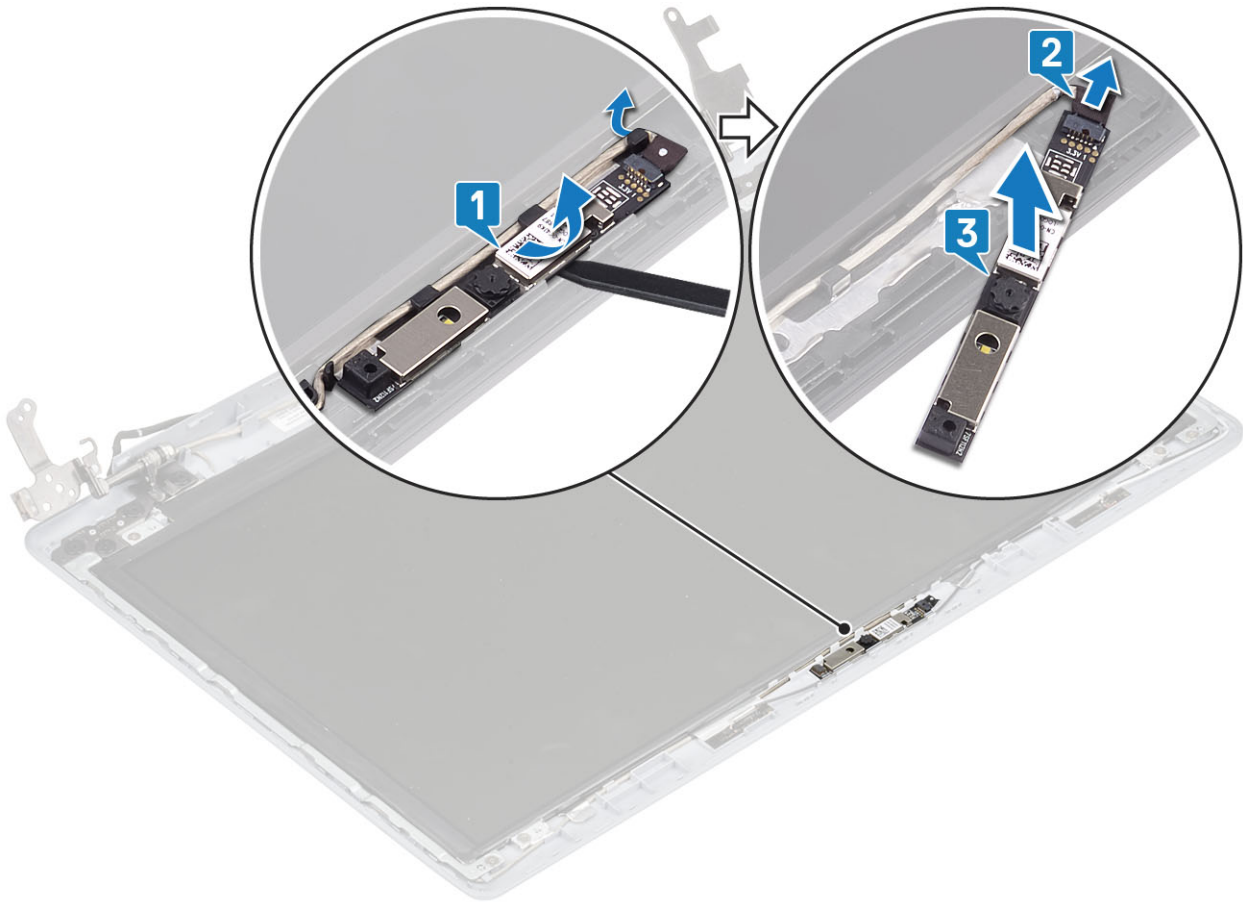

## Installing the camera

### Steps

- 1 Using the alignment post, adhere the camera module on the display back-cover and antenna assembly [1].
- 2 Route the camera cable through the routing channels [2].
- 3 Connect the camera cable to the camera module [3].

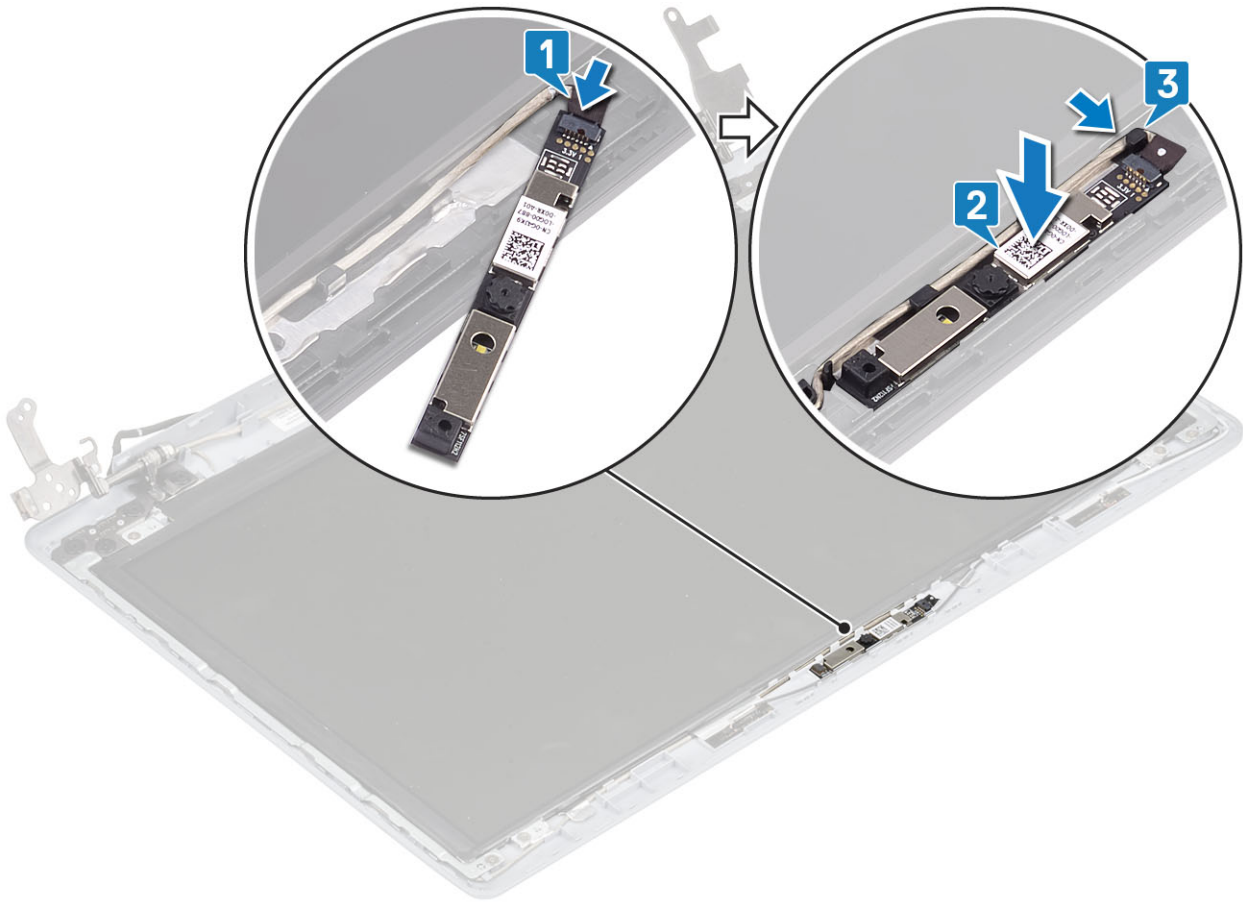

### Next steps

- 1 Install the [display bezel](#).
- 2 Install the [display assembly](#).
- 3 Install the [WLAN card](#).
- 4 Install the [battery](#).
- 5 Install the [base cover](#).
- 6 Install the [SD card](#).
- 7 Follow the procedures in [After working inside your computer](#).

## Display panel

### Removing the display panel

#### Prerequisites

- 1 Follow the procedure in [Before working inside your computer](#).
- 2 Remove the [SD card](#).
- 3 Remove the [base cover](#).
- 4 Remove the [battery](#).
- 5 Remove the [WLAN card](#).
- 6 Remove the [thermal plate](#).
- 7 Remove the [display assembly](#).

8 Remove the [display bezel](#)

**Steps**

- 1 Remove the four (M2x2) screws that secure the display panel to the display back-cover and antenna assembly [1].
- 2 Lift the display panel and turn it over [2].

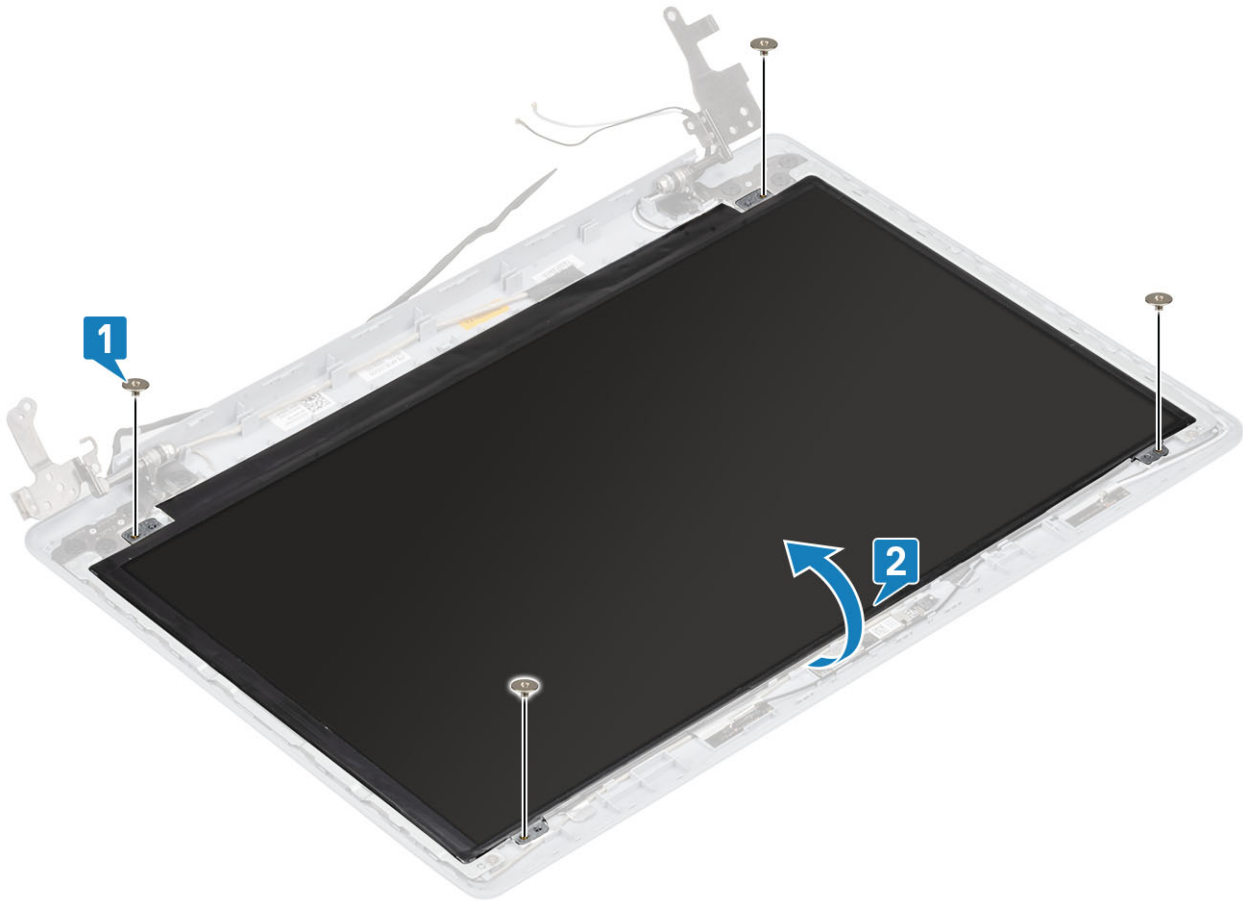

- 3 Peel the tape that secures the display cable to the back of the display panel [1].
- 4 Lift the latch and disconnect the display cable from the display-panel cable connector [2].
- 5 Lift the display panel away from the display back-cover and antenna assembly [3].

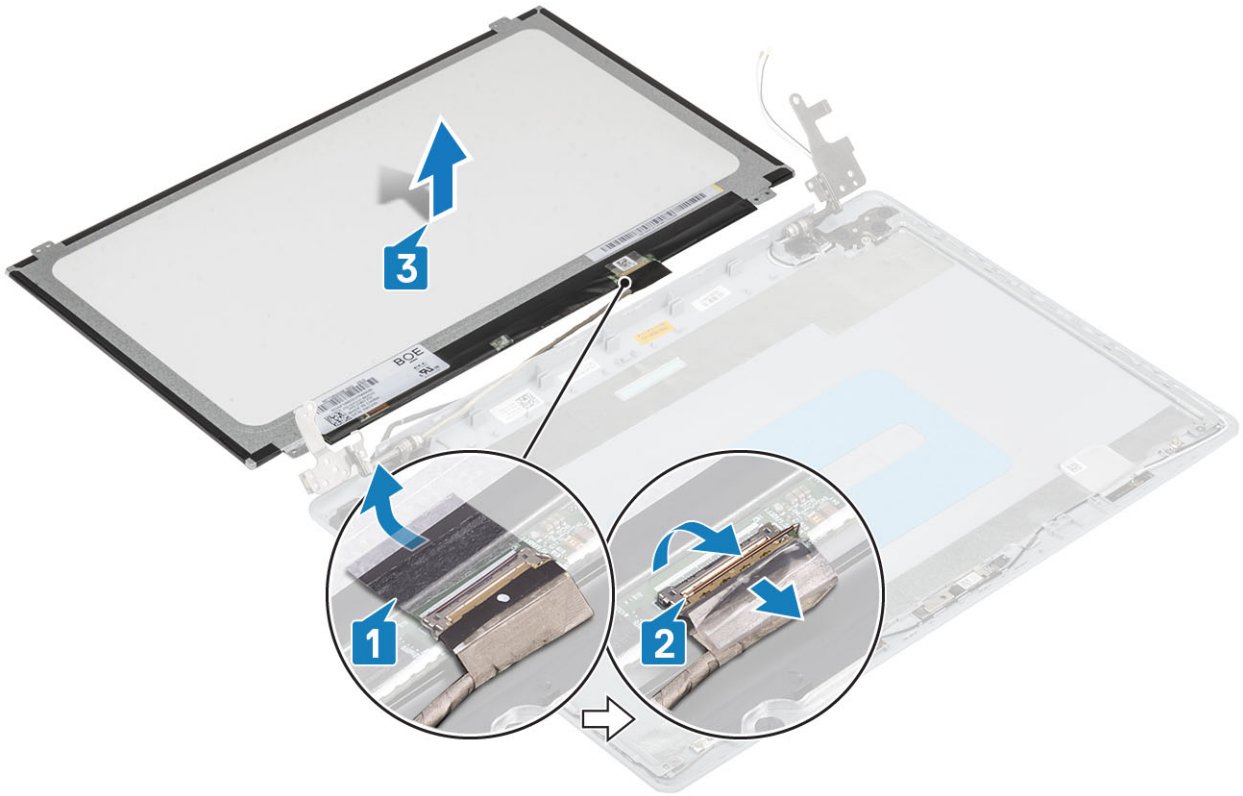

## Installation display panel

### Steps

- 1 Place the display panel on a flat and clean surface [1].
- 2 Connect the display cable to the connector at the back of the display panel and close the latch to secure the cable [2].
- 3 Adhere the tape that secures the display cable to the back of the display panel [3].
- 4 Turn the display panel over and place it on the display back-cover and antenna assembly [4].

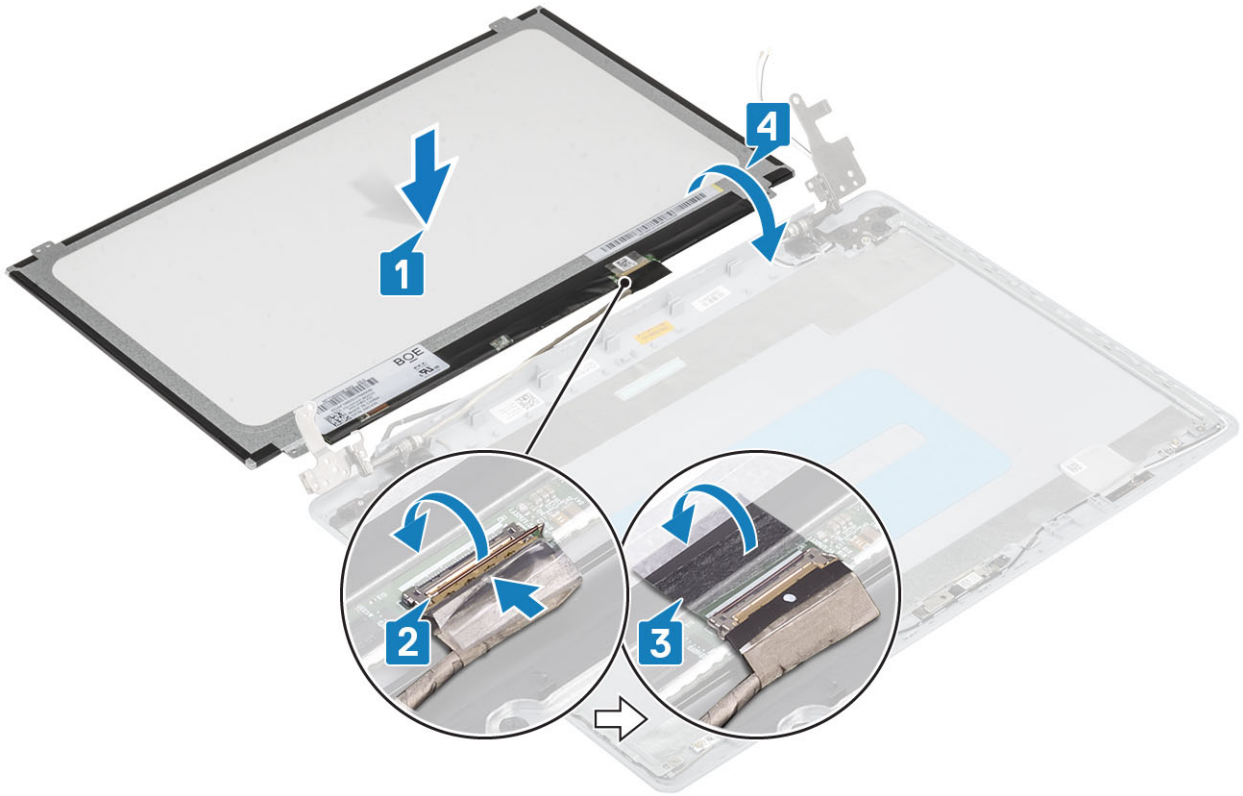

- 5 Align the screw holes on the display panel with the screw holes on the display back-cover and antenna assembly.
- 6 Replace the four (M2x2) screws that secure the display panel to the display back-cover and antenna assembly [1].

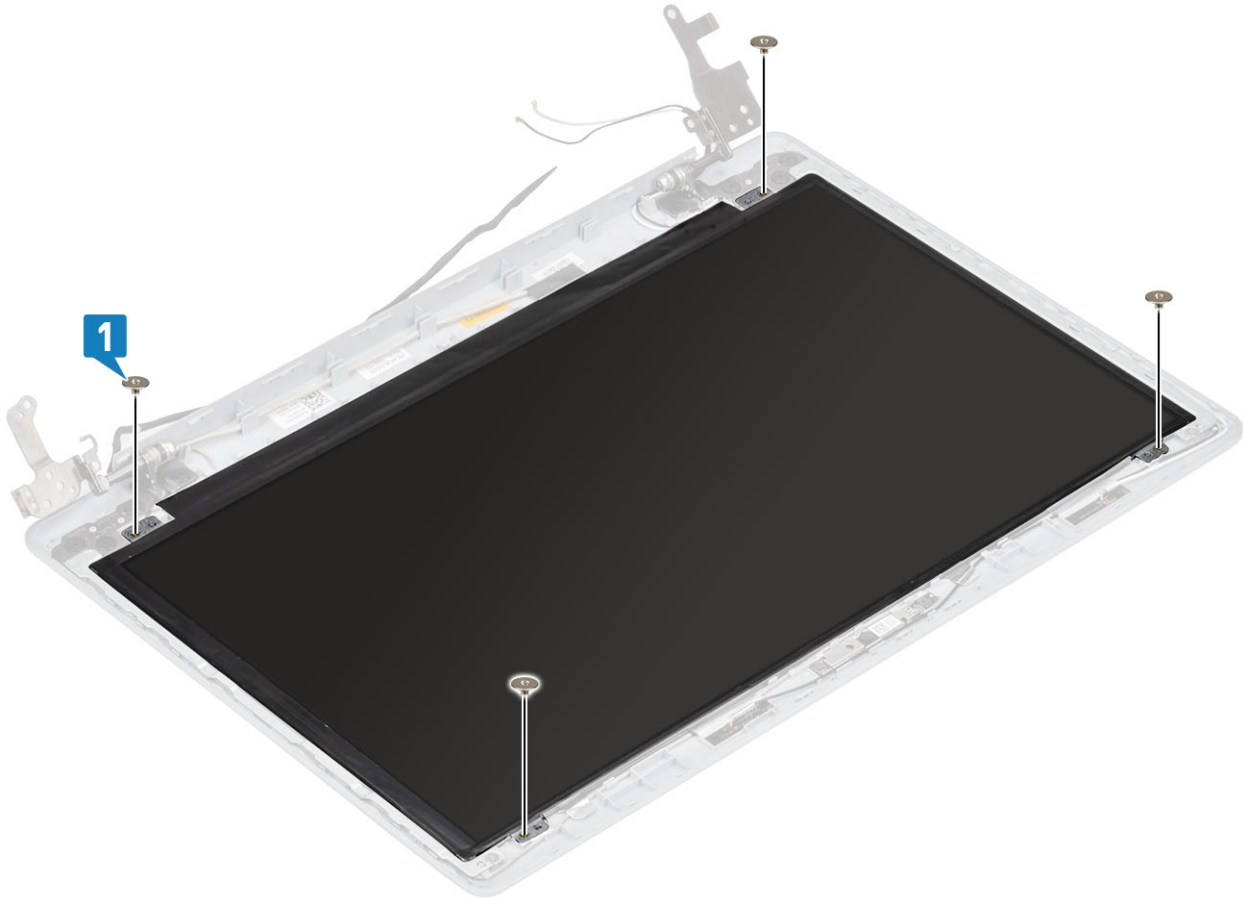

### Next steps

- 1 Install the [display bezel](#).
- 2 Install the [display assembly](#).
- 3 Install the [WLAN card](#).
- 4 Install the [battery](#).
- 5 Install the [base cover](#).
- 6 Install the [SD card](#).
- 7 Follow the procedures in [After working inside your computer](#).

## Display hinges

### Removing the display hinges

#### Prerequisites

- 1 Follow the procedure in [Before working inside your computer](#).
- 2 Remove the [SD card](#).
- 3 Remove the [base cover](#).
- 4 Remove the [battery](#)
- 5 Remove the [WLAN card](#)
- 6 Remove the [thermal plate](#)
- 7 Remove the [display assembly](#)
- 8 Remove the [display bezel](#)
- 9 Remove the [display panel](#)

#### Steps

- 1 Remove the eight (M2.5x2.5) screws and two (M2x2) screws that secure the hinges to the display back-cover and antenna assembly [1, 2].
- 2 Lift the hinges and brackets off the display back-cover and antenna assembly [3].

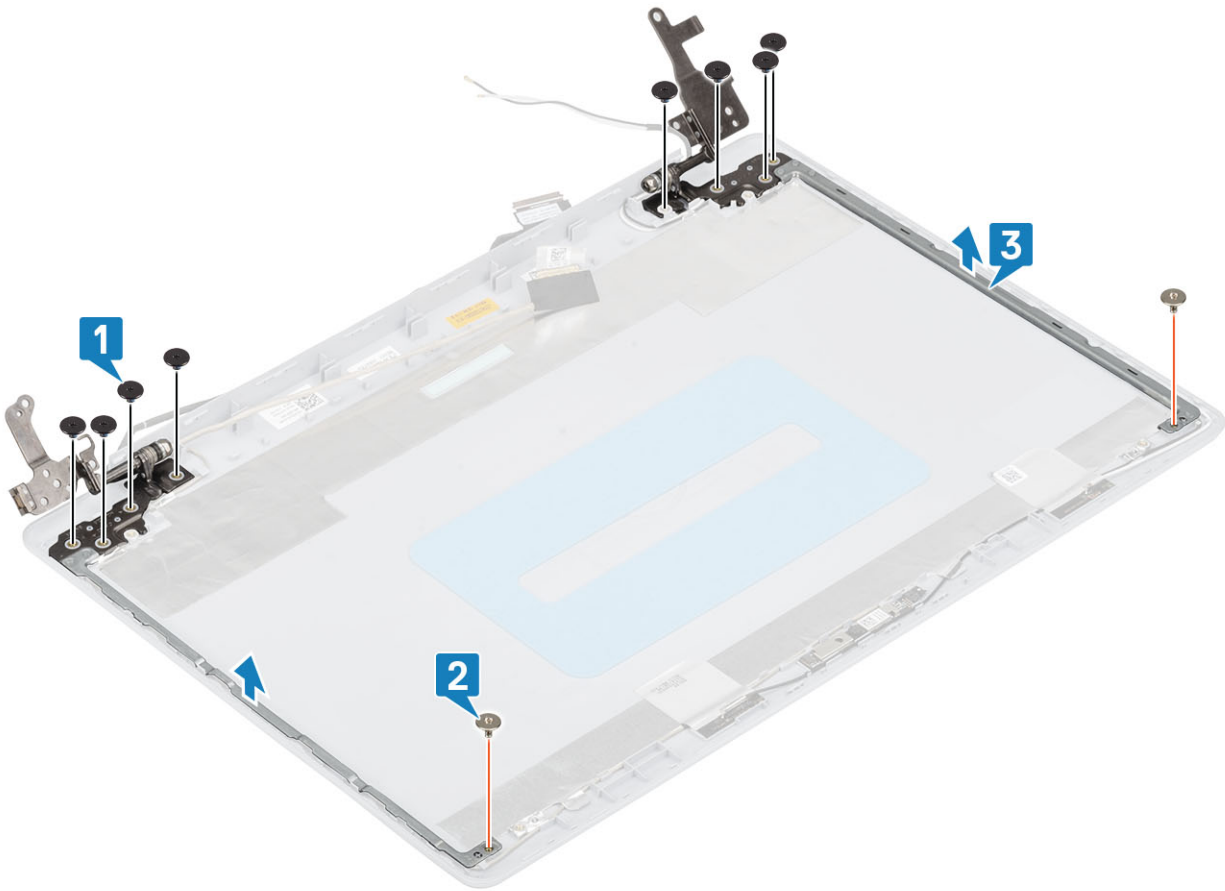

## Installing the display hinges

### Steps

- 1 Align the screw holes on the hinges and brackets with the screw holes on the display back-cover and antenna assembly [1].
- 2 Replace the eight (M2.5x2.5) screws and two (M2x2) screws that secure the hinges to the display back-cover and antenna assembly [2, 3].

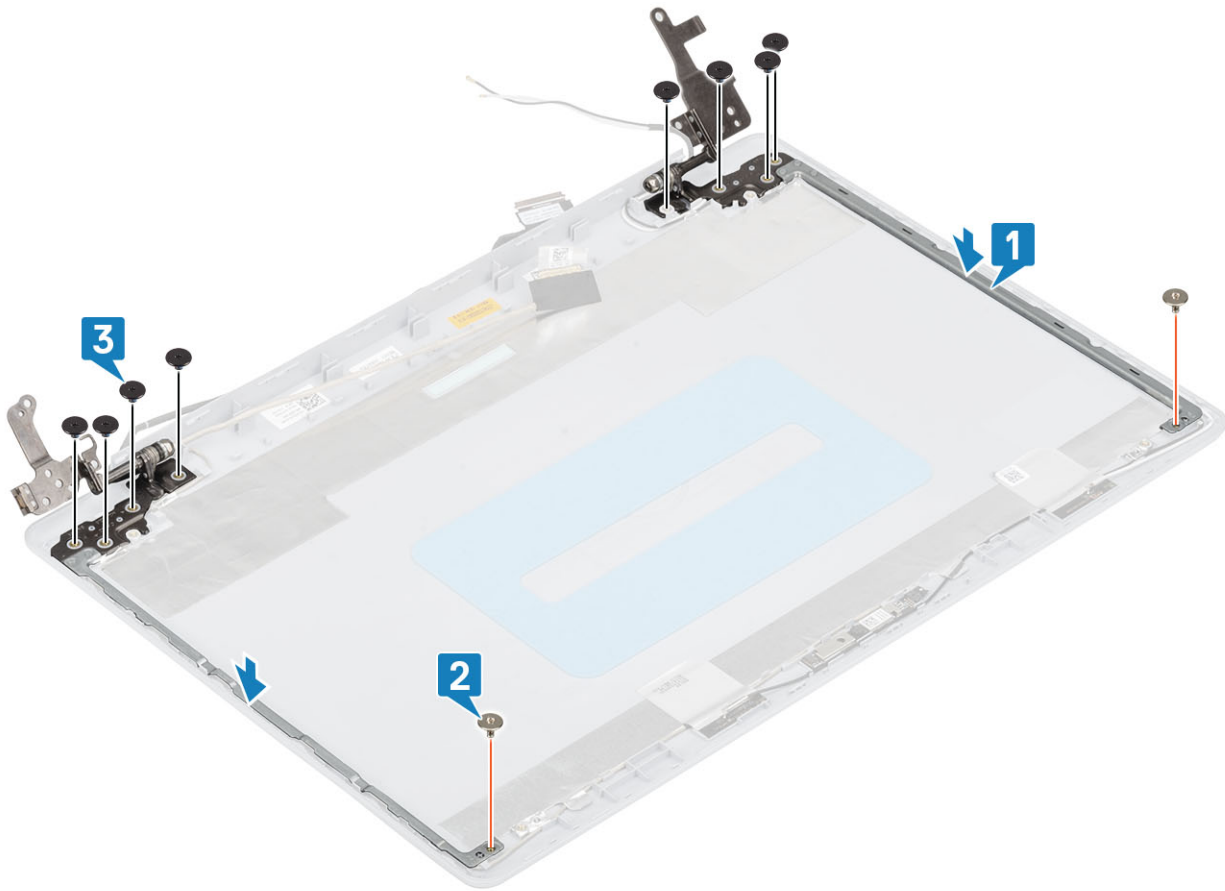

### Next steps

- 1 Install the [display panel](#).
- 2 Install the [display bezel](#).
- 3 Install the [display assembly](#).
- 4 Install the [WLAN card](#).
- 5 Install the [battery](#).
- 6 Install the [base cover](#).
- 7 Install the [SD card](#).
- 8 Follow the procedures in [After working inside your computer](#).

## Display cable

### Removing the display cable

#### Prerequisites

- 1 Follow the procedure in [Before working inside your computer](#).
- 2 Remove the [SD card](#).
- 3 Remove the [base cover](#).
- 4 Remove the [battery](#).
- 5 Remove the [WLAN card](#).
- 6 Remove the [thermal plate](#).

- 7 Remove the [display assembly](#)
- 8 Remove the [display bezel](#)
- 9 Remove the [display panel](#)
- 10 Remove the [display hinges](#)

### Steps

- 1 Remove the camera cable and the display cable from the routing guides on the display back-cover and antenna assembly [1].
- 2 Peel the adhesive that secures the camera cable [2].
- 3 Lift the camera cable and the display cable off the display back-cover and antenna assembly [3].

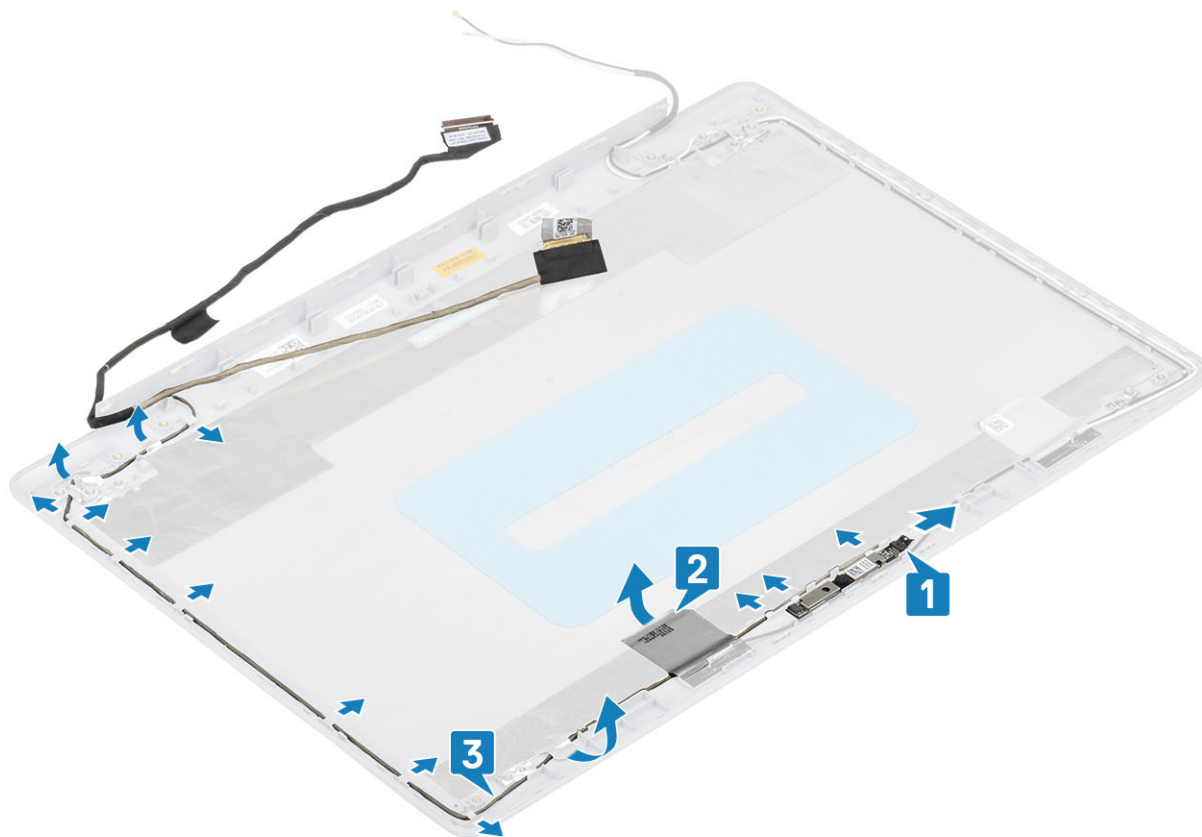

## Installing the display cable

### Steps

- 1 Place the display cable and camera cable on the display back-cover and antenna assembly [1].
- 2 Affix the adhesive that secures the camera cable [2].
- 3 Route the display cable and camera cable through the routing guides on the display back-cover and antenna assembly [3].

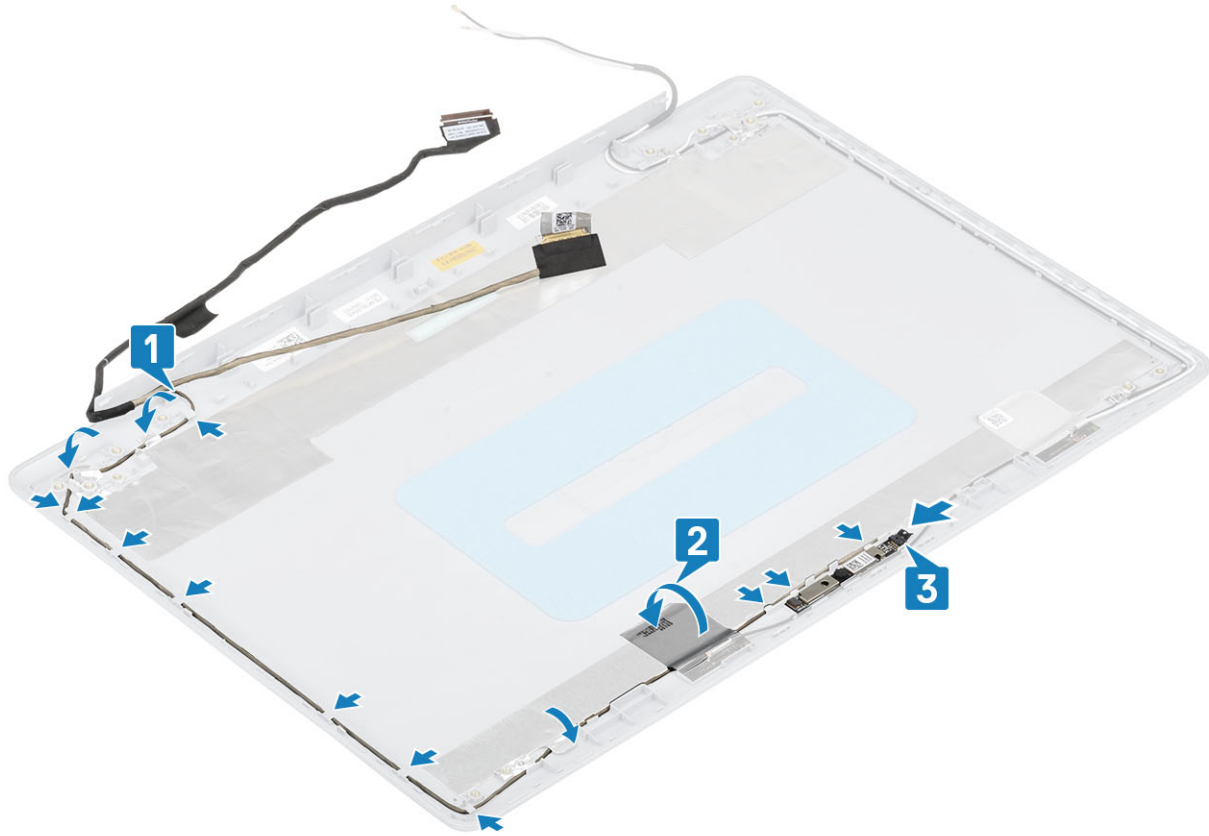

#### Next steps

- 1 Install the [display hinges](#).
- 2 Install the [display panel](#).
- 3 Install the [display bezel](#).
- 4 Install the [display assembly](#).
- 5 Install the [WLAN card](#).
- 6 Install the [battery](#).
- 7 Install the [base cover](#).
- 8 Install the [SD card](#).
- 9 Follow the procedures in [After working inside your computer](#).

## Power button board

### Removing the power button board

#### Prerequisite

- 1 Follow the procedure in [Before working inside your computer](#).
- 2 Remove the [SD card](#).
- 3 Remove the [base cover](#).
- 4 Remove the [battery](#)
- 5 Remove the [WLAN card](#)
- 6 Remove the [thermal plate](#)

## 7 Remove the [display assembly](#)

### Steps

- 1 Open the latch and disconnect the power-button board cable from the system board [1].
- 2 Peel off the tape that secures the power-button board to the palm rest and keyboard assembly [2].
- 3 Remove the screw (M2x3) that secures the power-button board to the palm rest and keyboard assembly [3].
- 4 Lift the power-button board, along with the cable, off the palm rest and keyboard assembly [4].

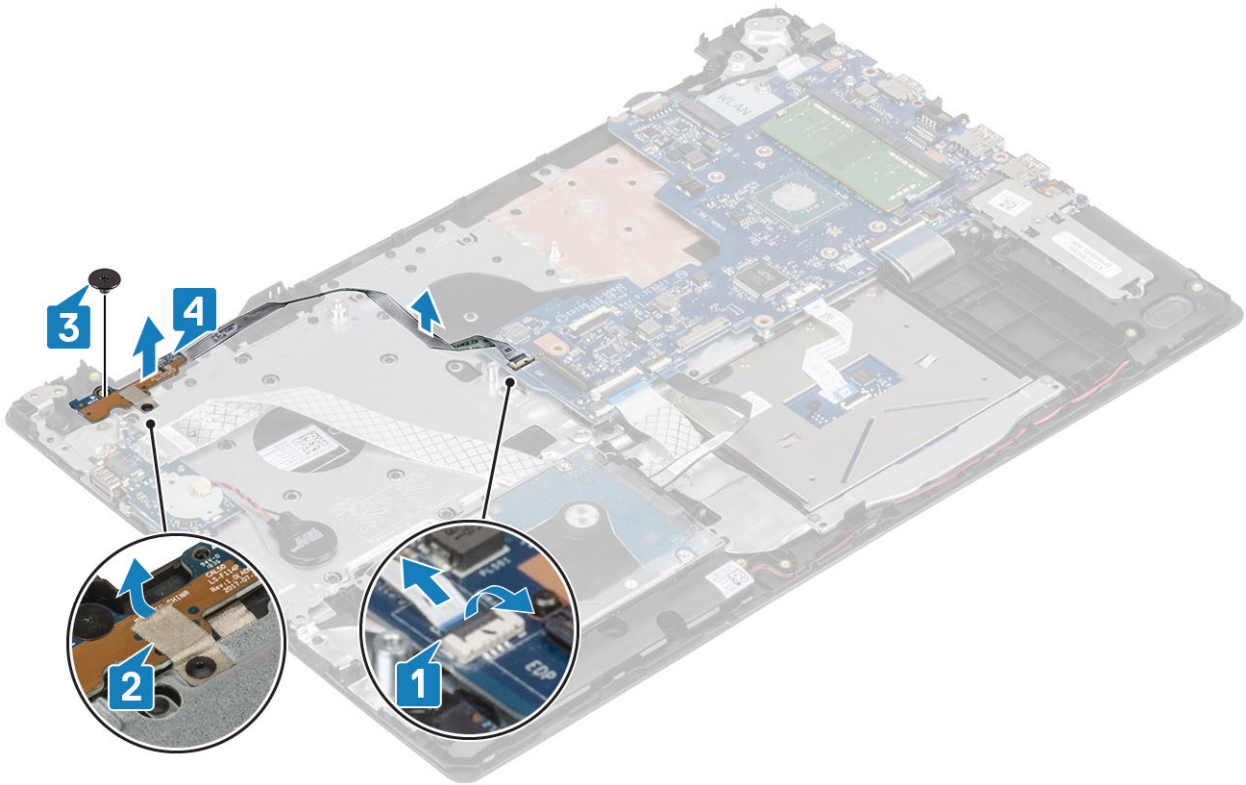

## Installing the power button board

### Steps

- 1 Align and place the power button on the palm rest and keyboard assembly [1].
- 2 Replace the screw (M2x2) that secures the power button to the palm rest and keyboard assembly [2].
- 3 Affix the tape to secure the power button board to the palm rest and keyboard assembly [3]
- 4 Connect the power button board cable to the connector on the system board [4]

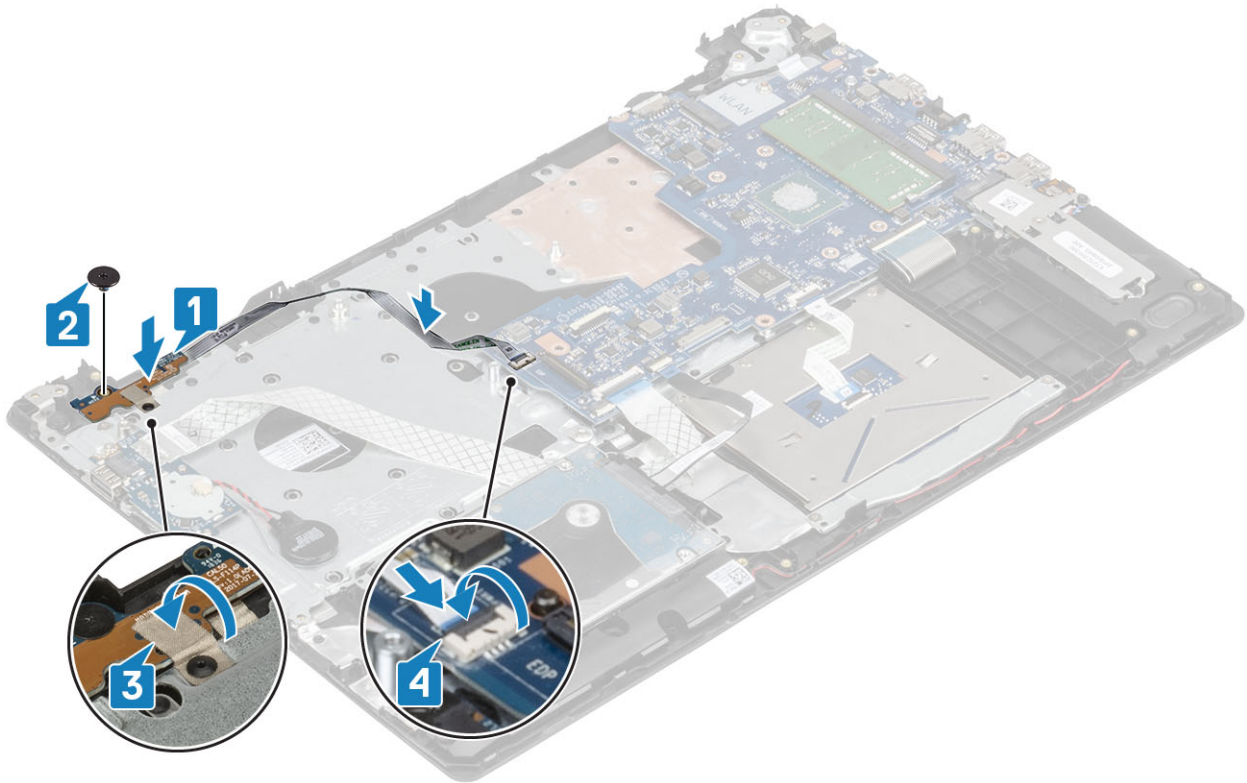

### Next steps

- 1 Install the [display assembly](#).
- 2 Install the [thermal pad](#).
- 3 Install the [WLAN card](#).
- 4 Install the [battery](#).
- 5 Install the [base cover](#).
- 6 Install the [SD card](#).
- 7 Follow the procedures in [After working inside your computer](#).

## Power button

### Removing the power button

#### Prerequisite

- 1 Follow the procedure in [Before working inside your computer](#).
- 2 Remove the [SD card](#).
- 3 Remove the [base cover](#).
- 4 Remove the [battery](#)
- 5 Remove the [WLAN card](#)
- 6 Remove the [thermal plate](#)
- 7 Remove the [display assembly](#)
- 8 Remove the [power button board](#)

## Steps

- 1 Remove the M2x2 screw that secures the power button to the palm rest and keyboard assembly [1].
- 2 Lift the power button off the palm rest and keyboard assembly [2].

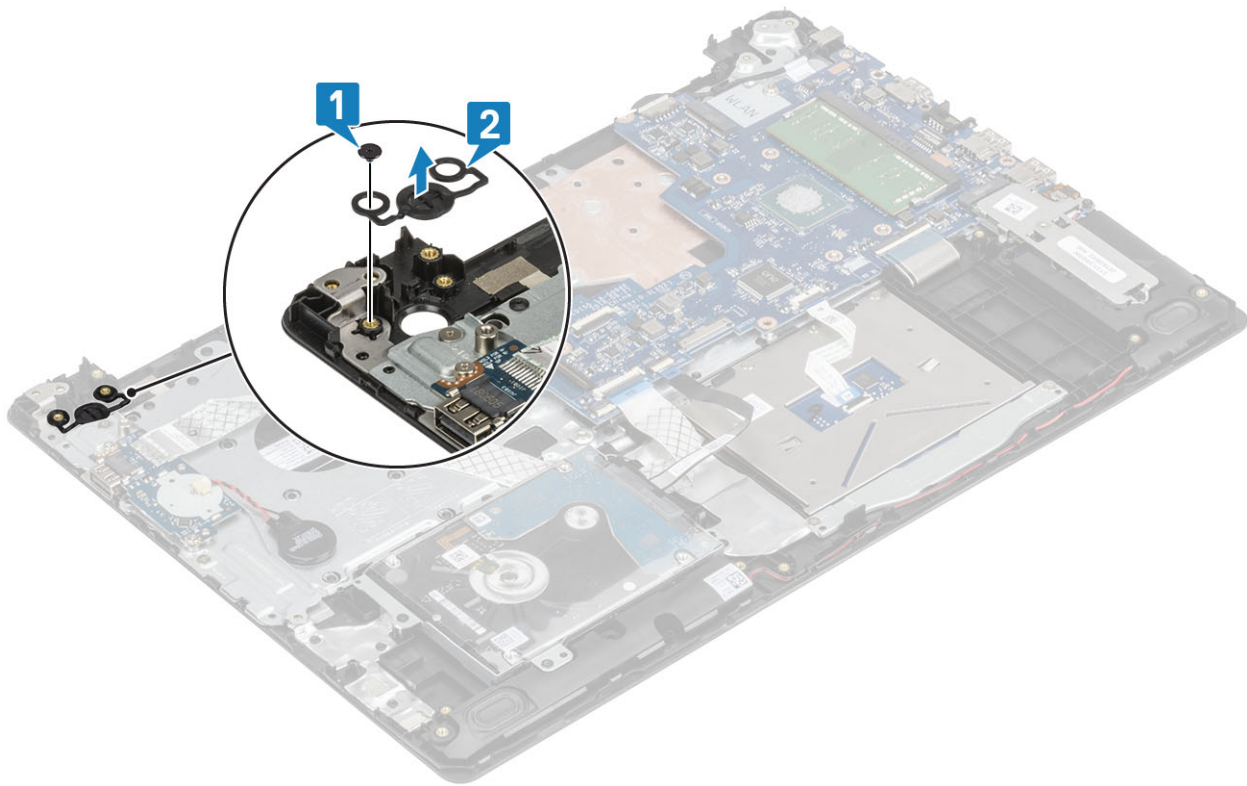

## Installing the power button

### Steps

- 1 Align and place the power button on the palm rest and keyboard assembly [1].
- 2 Replace the M2x2 screw that secures the power button to the palm rest and keyboard assembly [2].

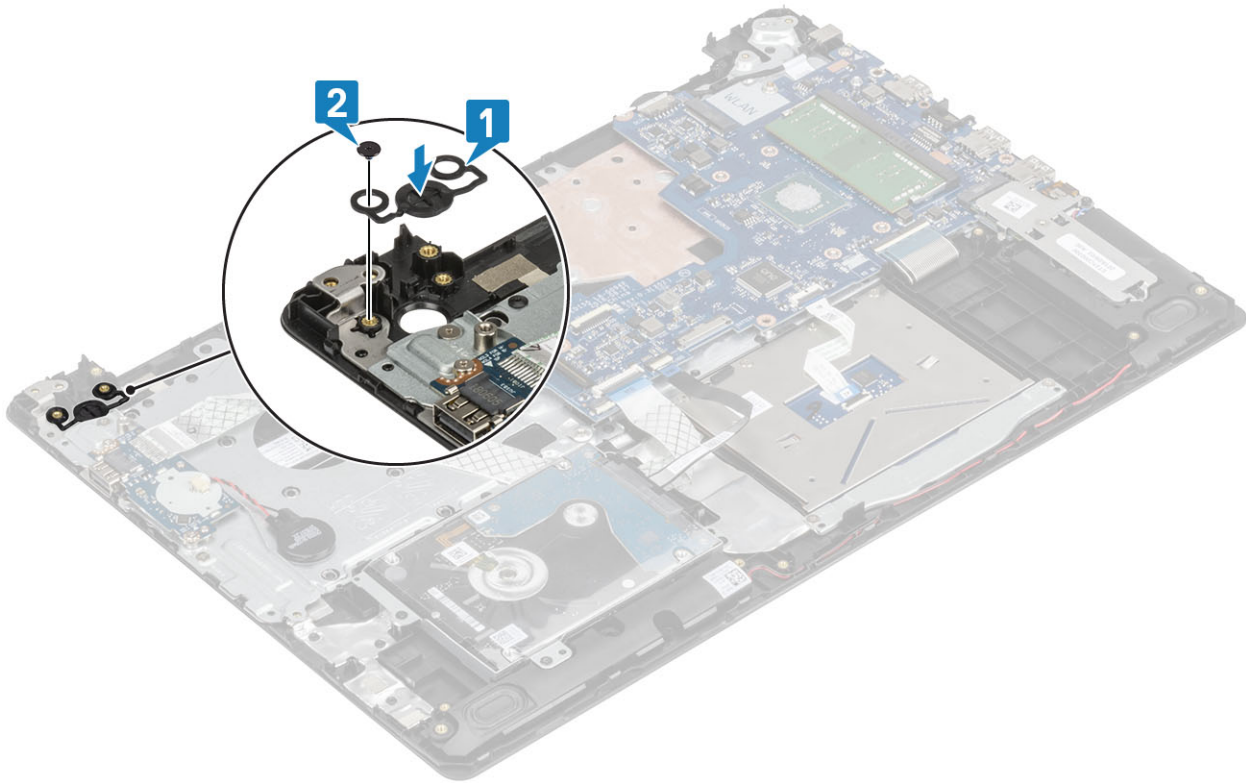

### Next steps

- 1 Install the [power button board](#).
- 2 Install the [display assembly](#).
- 3 Install the [thermal pad](#).
- 4 Install the [WLAN card](#).
- 5 Install the [battery](#).
- 6 Install the [base cover](#).
- 7 Install the [SD card](#).
- 8 Follow the procedures in [After working inside your computer](#).

## Power connector port

### Removing the power connector port

#### Prerequisite

- 1 Follow the procedure in [Before working inside your computer](#).
- 2 Remove the [SD card](#).
- 3 Remove the [base cover](#).
- 4 Remove the [battery](#)
- 5 Remove the [WLAN card](#)
- 6 Remove the [display assembly](#)

#### Steps

- 1 Disconnect the power-adaptor port cable from the connector on the system board [1].
- 2 Note the power-adaptor port cable routing and remove it from the routing guides on the palm rest and keyboard assembly [2].

- 3 Remove the screw (M2x2) that secures the power-adaptor port to the palm rest and keyboard assembly [3].
- 4 Lift the power-adaptor port, along with its cable, off the palm rest and keyboard assembly [4].

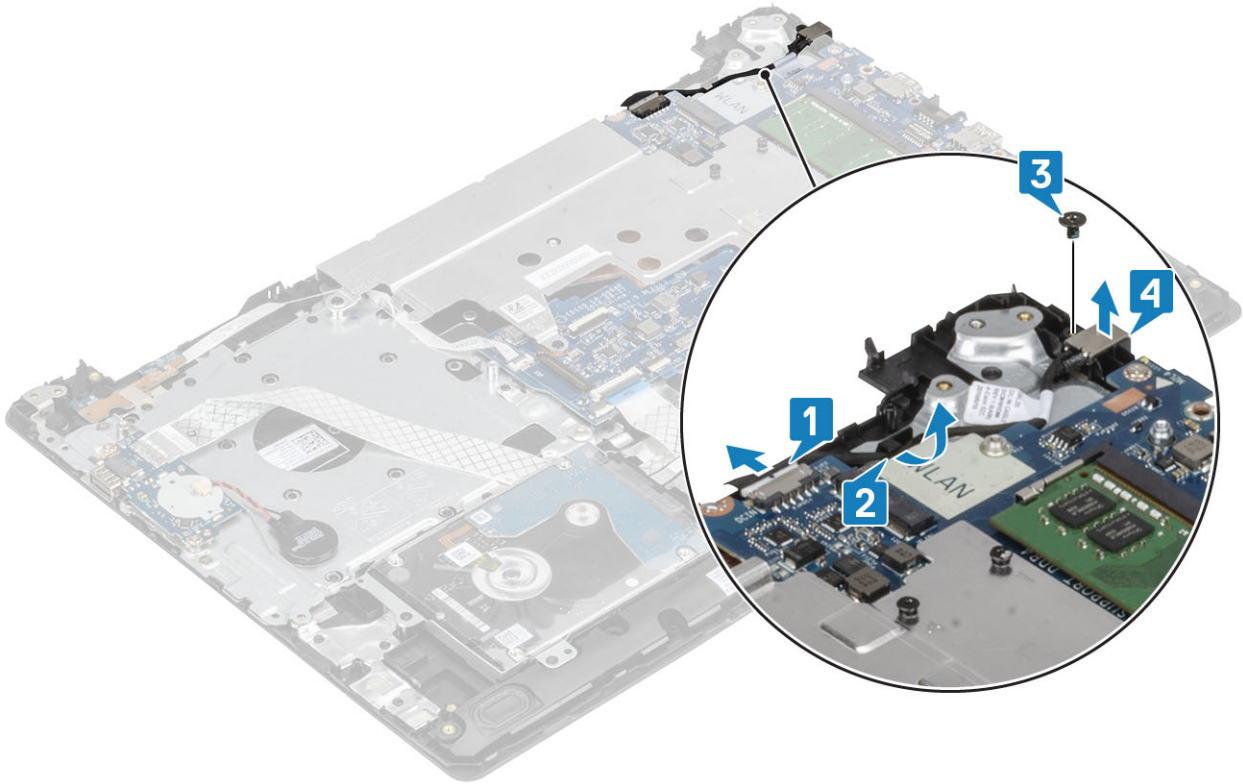

## Installing power connector port

- 1 Align the screw hole on the power-adaptor port with the screw hole on the palm rest and keyboard assembly [1].
- 2 Replace the screw (M2x2) that secures the power-adaptor port to the palm rest and keyboard assembly [2].
- 3 Route the power-adaptor port cable through the routing guides on the palm rest and keyboard assembly [3].
- 4 Connect the power-adaptor port cable to the connector on the system board [4].

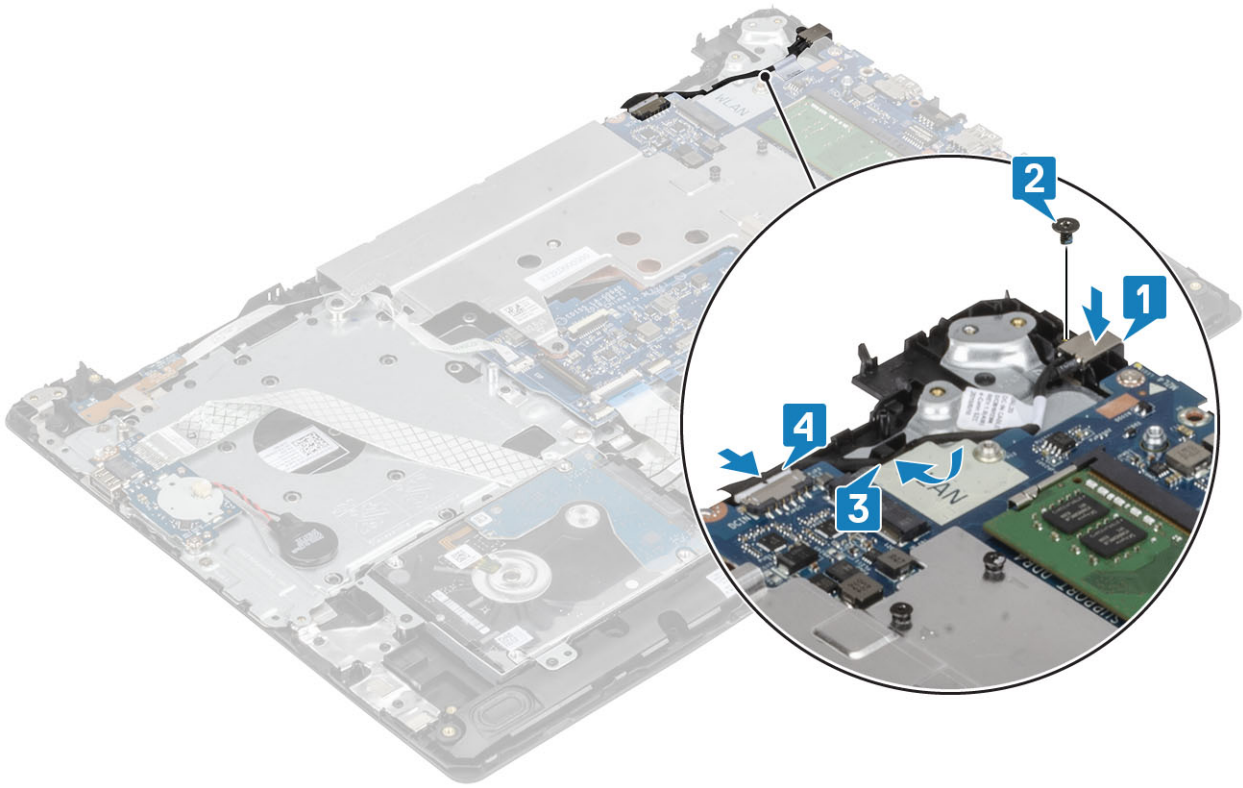

## Display back-cover

### Removing the display back-cover

#### Prerequisites

- 1 Follow the procedure in [Before working inside your computer](#).
- 2 Remove the [SD card](#).
- 3 Remove the [base cover](#).
- 4 Remove the [battery](#)
- 5 Remove the [WLAN card](#)
- 6 Remove the [thermal plate](#)
- 7 Remove the [display assembly](#)
- 8 Remove the [display bezel](#)
- 9 Remove the [display panel](#)
- 10 Remove the [display hinges](#)
- 11 Remove the [display cable](#)

### About this task

After performing all the preceding steps, you are left with the display back-cover.

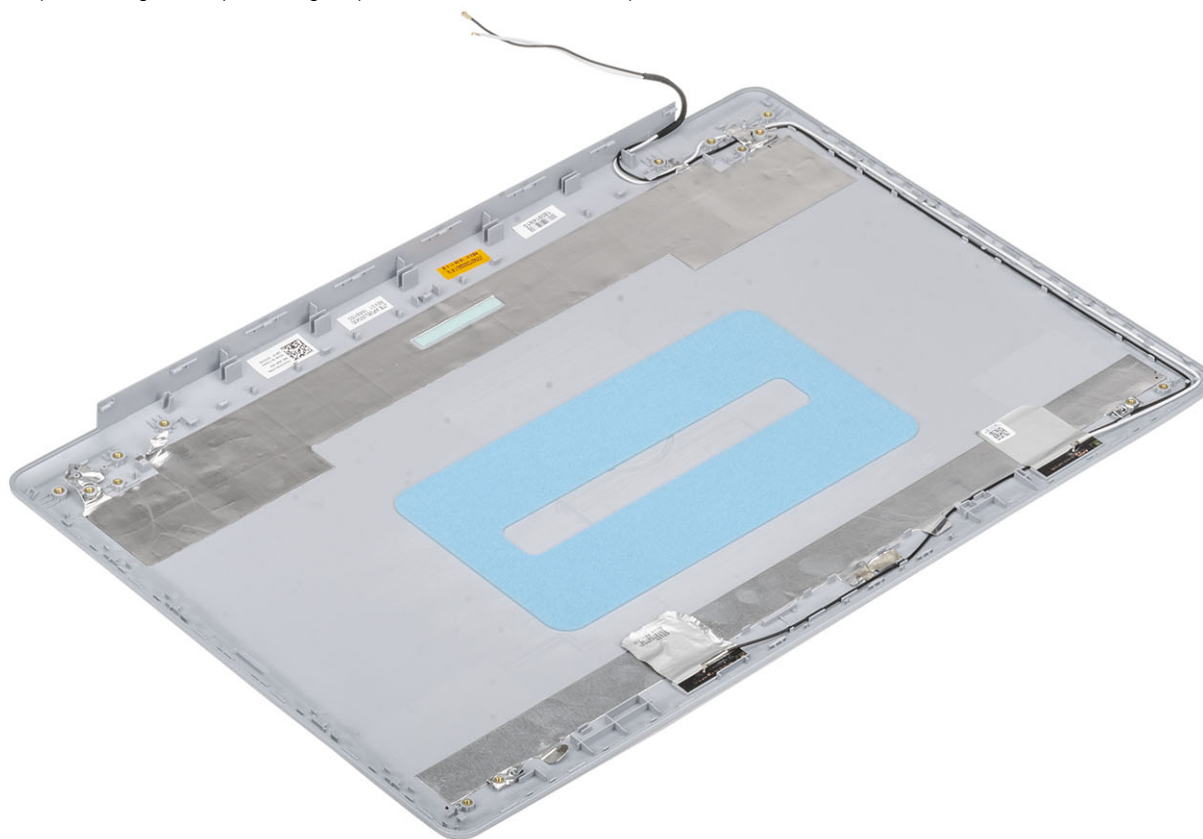

## Palm-rest and keyboard assembly

### Removing the palmrest and keyboard assembly

#### Prerequisites

- 1 Follow the procedure in [before working inside your computer](#)
- 2 Remove the [SD card](#).
- 3 Remove the [base cover](#).
- 4 Remove the [battery](#)
- 5 Remove the [memory](#)
- 6 Remove the [WLAN](#)
- 7 Remove the [SSD](#)
- 8 Remove the [speakers](#)
- 9 Remove the [coin-cell battery](#)
- 10 Remove the [hard drive assembly](#)
- 11 Remove the [thermal pad](#)
- 12 Remove the [IO board](#)
- 13 Remove the [touchpad](#)
- 14 Remove the [display assembly](#)
- 15 Remove the [power button board](#)
- 16 Remove the [power button](#)

- 17 Remove the [display hinges](#)
- 18 Remove the [power adapter port](#)
- 19 Remove the [system board](#)

**About this task**

After performing the preceding steps, you are left with the palmrest and keyboard assembly.



# Troubleshooting

## Enhanced Pre-Boot System Assessment (ePSA) diagnostics

**⚠ CAUTION:** Use the ePSA diagnostics to test only your computer. Using this program with other computers may cause invalid results or error messages.

The ePSA diagnostics (also known as system diagnostics) performs a complete check of your hardware. The ePSA is embedded with the BIOS and is launched by the BIOS internally. The embedded system diagnostics provides a set of options for particular devices or device groups allowing you to:

- Run tests automatically or in an interactive mode
- Repeat tests
- Display or save test results
- Run thorough tests to introduce additional test options to provide extra information about the failed device(s)
- View status messages that inform you if tests are completed successfully
- View error messages that inform you of problems encountered during testing

**📌 NOTE:** Some tests for specific devices require user interaction. Always ensure that you are present at the computer terminal when the diagnostic tests are performed.

## Running the ePSA diagnostics

- 1 Turn on your computer.
- 2 As the computer boots, press the F12 key as the Dell logo appears.
- 3 On the boot menu screen, select the **Diagnostics** option.
- 4 Click the arrow at the bottom left corner.  
Diagnostics front page is displayed.
- 5 Click the arrow in the lower-right corner to go to the page listing.  
The items detected are listed.
- 6 To run a diagnostic test on a specific device, press Esc and click **Yes** to stop the diagnostic test.
- 7 Select the device from the left pane and click **Run Tests**.
- 8 If there are any issues, error codes are displayed.  
Note the error code and validation number and contact Dell.

## System diagnostic lights

### Battery-status light

Indicates the power and battery-charge status.

**Solid white** — Power adapter is connected and the battery has more than 5 percent charge.

**Amber** — Computer is running on battery and the battery has less than 5 percent charge.

**Off**

- Power adapter is connected and the battery is fully charged.
- Computer is running on battery and the battery has more than 5 percent charge.
- Computer is in sleep state, hibernation, or turned off.

The power and battery-status light blinks amber along with beep codes indicating failures.

For example, the power and battery-status light blinks amber two times followed by a pause, and then blinks white three times followed by a pause. This 2,3 pattern continues until the computer is turned off indicating no memory or RAM is detected.

The following table shows different power and battery-status light patterns and associated problems.

**Table 4. LED codes**

Diagnostic light codes	Problem description
2,1	Processor failure
2,2	System board: BIOS or ROM (Read-Only Memory) failure
2,3	No memory or RAM (Random-Access Memory) detected
2,4	Memory or RAM (Random-Access Memory) failure
2,5	Invalid memory installed
2,6	System-board or chipset error
2,7	Display failure
3,1	Coin-cell battery failure
3,2	PCI, video card/chip failure
3,3	Recovery image not found
3,4	Recovery image found but invalid
3,5	Power-rail failure
3,6	System BIOS Flash incomplete
3,7	Management Engine (ME) error

**Camera status light:** Indicates whether the camera is in use.

- Solid white — Camera is in use.
- Off — Camera is not in use.

**Caps Lock status light:** Indicates whether Caps Lock is enabled or disabled.

- Solid white — Caps Lock enabled.
- Off — Caps Lock disabled.

## Flashing BIOS (USB key)

- 1 Follow the procedure from step 1 to step 7 in "[Flashing the BIOS](#)" to download the latest BIOS setup program file.
- 2 Create a bootable USB drive. For more information see the knowledge base article [SLN143196](#) at [www.dell.com/support](http://www.dell.com/support).
- 3 Copy the BIOS setup program file to the bootable USB drive.
- 4 Connect the bootable USB drive to the computer that needs the BIOS update.
- 5 Restart the computer and press **F12** when the Dell logo is displayed on the screen.
- 6 Boot to the USB drive from the **One Time Boot Menu**.
- 7 Type the BIOS setup program filename and press **Enter**.
- 8 The **BIOS Update Utility** appears. Follow the instructions on the screen to complete the BIOS update.

# Flashing the BIOS

## About this task

You may need to flash (update) the BIOS when an update is available or when you replace the system board. Follow these steps to flash the BIOS:

### Steps

- 1 Turn on your computer.
- 2 Go to [www.dell.com/support](http://www.dell.com/support).
- 3 Click **Product support**, enter the Service Tag of your computer, and then click **Submit**.

**NOTE:** If you do not have the Service Tag, use the auto-detect feature or manually browse for your computer model.

- 4 Click **Drivers & downloads > Find it myself**.
- 5 Select the operating system installed on your computer.
- 6 Scroll down the page and expand **BIOS**.
- 7 Click **Download** to download the latest version of the BIOS for your computer.
- 8 After the download is complete, navigate to the folder where you saved the BIOS update file.
- 9 Double-click the BIOS update file icon and follow the instructions on the screen.

# Backup media and recovery options

Dell proposes multiple options for recovering Windows operating system on your Dell PC. For more information, see [Dell Windows Backup Media and Recovery Options](#).

# WiFi power cycle

## About this task

If your computer is unable to access the internet due to WiFi connectivity issues a WiFi power cycle procedure may be performed. The following procedure provides the instructions on how to conduct a WiFi power cycle:

**NOTE:** Some ISPs (Internet Service Providers) provide a modem/router combo device.

### Steps

- 1 Turn off your computer.
- 2 Turn off the modem.
- 3 Turn off the wireless router.
- 4 Wait for 30 seconds.
- 5 Turn on the wireless router.
- 6 Turn on the modem.
- 7 Turn on your computer.

# Flea power release

## About this task

Flea power is the residual static electricity that remains on the computer even after it has been powered off and the battery has been removed. The following procedure provides the instructions on how to conduct flea power release:

### Steps

- 1 Turn off your computer.
- 2 Disconnect the power adapter from your computer.
- 3 Press and hold the power button for 15 seconds to drain the flea power.
- 4 Connect the power adapter to your computer.
- 5 Turn on your computer.

# Getting help

## Contacting Dell

### Prerequisite

① **NOTE:** If you do not have an active Internet connection, you can find contact information on your purchase invoice, packing slip, bill, or Dell product catalog.

### About this task

Dell provides several online and telephone-based support and service options. Availability varies by country and product, and some services may not be available in your area. To contact Dell for sales, technical support, or customer service issues:

### Steps

- 1 Go to **Dell.com/support**.
- 2 Select your support category.
- 3 Verify your country or region in the **Choose a Country/Region** drop-down list at the bottom of the page.
- 4 Select the appropriate service or support link based on your need.