



VEP4600

Setup Guide

Notes, cautions, and warnings

-  **NOTE:** A NOTE indicates important information that helps you make better use of your product.
-  **CAUTION:** A CAUTION indicates either potential damage to hardware or loss of data and tells you how to avoid the problem.
-  **WARNING:** A WARNING indicates a potential for property damage, personal injury, or death.

© 2019 Dell Inc. or its subsidiaries. All rights reserved. Dell, EMC, and other trademarks are trademarks of Dell Inc. or its subsidiaries. Other trademarks may be trademarks of their respective owners.

Contents

1 About this guide.....	5
Related documents.....	6
Information symbols.....	6
2 Site preparations.....	7
Site selection.....	7
Cabinet placement.....	8
Rack mounting.....	8
System ground.....	8
Fans and airflow.....	9
Power.....	9
Storing components.....	9
3 VEP4600 installation.....	11
Unpack.....	11
VEP Expansion Card installation.....	12
Ground cable.....	12
Rack or cabinet installation.....	14
Rack mount safety considerations.....	14
Two-post installation.....	15
1U front-rack installation.....	15
Four-post installation.....	17
Optics installation.....	19
Optics removal.....	19
Platform power-up.....	20
Power up sequence.....	20
4 Specifications.....	21
Chassis physical design.....	21

VEP4600 Expansion Card antennas.....	23
Whip antennas on the WiFi and LTE Cards	25
GPS antenna on the VEP4600 LTE Card	26
Agency compliance.....	27
USA Federal Communications Commission statement.....	27
Industry Canada Statement.....	29
Brasil – Aviso da Anatel.....	31
European Union EMC directive conformance statement.....	31
Japan VCCI compliance for class A equipment.....	32
Korean certification of compliance.....	34
Mexican certification of compliance.....	35
Taiwanese certification of compliance.....	35
Singapore certification of compliance.....	35

5 Support..... 37

About this guide

This guide provides site preparation recommendations, step-by-step procedures for rack mounting and desk mounting, inserting modules, and connecting to a power source.

- ⚠ CAUTION:** To avoid electrostatic discharge (ESD) damage, wear grounding wrist straps when handling this equipment.
- ⚠ WARNING:** Only trained and qualified personnel can install this equipment. Read this guide before you install and power up this equipment. This equipment contains one power cable. Disconnect the power cable before servicing.
- ⚠ WARNING:** This equipment contains optical transceivers, which comply with the limits of Class 1 laser radiation.



Figure 1. Class 1 laser product tag

- ⚠ WARNING:** When a cable is not connected, visible and invisible laser radiation may be emitted from the aperture of the optical transceiver ports. Avoid exposure to laser radiation, and do not stare into open apertures.

Topics:

- [Related documents](#)
- [Information symbols](#)

Related documents

For more information about the Virtual Edge Platform 4600 (VEP4600), see the following documents:

- *VEP4600 Installation Guide*
- *VEP4600 Release Notes*

 **NOTE:** For the most recent documentation, see the support site: <https://www.dell.com/support>.

Information symbols

This book uses the following information symbols:

 **NOTE:** The Note icon signals important operational information.

 **CAUTION:** The Caution icon signals information about situations that could result in equipment damage or loss of data.

 **WARNING:** The Warning icon signals information about hardware handling that could result in injury.

 **WARNING:** The ESD Warning icon requires that you take electrostatic precautions when handling the device.

Site preparations

VEP4600 is universal customer premise equipment (uCPE). To connect the service provider edge or enterprise branch to the cloud, use VEP4600 to host multiple virtual network functions (VNFs), such as SD-WAN, routing, firewall, and deep-packet inspection.

For more information about VEP4600 specifications, see [Chassis physical design](#).

NOTE: Install the platform into a rack or cabinet before installing any optional components.

Topics:

- [Site selection](#)
- [Cabinet placement](#)
- [Rack mounting](#)
- [System ground](#)
- [Fans and airflow](#)
- [Power](#)
- [Storing components](#)

Site selection

CAUTION: The mezzanine cards are intended for professional installation only.

CAUTION: Professional installation instructions: This product is designed for specific applications and needs to be installed by qualified personnel with RF and regulatory related knowledge. The general user shall not attempt to install or change the setting.

Install your equipment in restricted access areas. A restricted access area is one where service personnel can only gain access using a special tool, lock, key, or other means of security. The authority responsible for the location controls access to the restricted area.

Ensure that the area where you install your platform meets the following safety requirements:

- Near an adequate power source. Connect the platform to the appropriate branch circuit protection according to your local electrical codes.
- Environmental—platform location—continuous temperature range is from 0°C to 45°C (32°F to 113°F).
- Operating humidity is from 5 to 90 percent non-condensing, continuous.
- In a dry, clean, well-ventilated, and temperature-controlled room, away from heat sources such as hot cooling vents or direct sunlight.
- Away from sources of severe electromagnetic noise.
- Positioned in a rack or cabinet, or on a desktop with adequate space in the front, back, and sides for proper ventilation and access.
- Install the platform in Information Technology Rooms in accordance with Article 645 of the National Electrical Code and NFPA 75.

For more information about platform storage and environmental temperatures, see [Specifications](#).

Cabinet placement

Install VEP4600 only in indoor cabinets designed for use in a controlled environment.

Do not install the platform in outside cabinets. For cabinet placement requirements, see [Site selection](#).

The cabinet must meet minimum size requirements. Airflow must be in accordance with the Electronic Industries Alliance (EIA) standard. Ensure that there is a minimum of 5 inches (12.7 cm) between the intake and exhaust vents and the cabinet wall.

Rack mounting

When you prepare your equipment rack, ensure that the rack is grounded. Ground the equipment rack to the same ground point the power service in your area uses. The ground path must be permanent.

System ground

Dell recommends grounding your system. Use VEP4600 in a CBN.

Fans and airflow

Fan installation is done as part of the factory install based on stock keeping unit (SKU) type. VEP 4600 supports an AC normal fan unit with fan airflow from the I/O to the PSU.

For proper ventilation, position the platform in an equipment rack or cabinet with a minimum of 5 inches (12.7 cm) of clearance around the exhaust vents. The fan speed varies based on internal temperature monitoring. The platform never intentionally turns off the fans.

Power

Connect the platform to the applicable power source using the appropriate power cable. An AC power cable is included with the platform.

When installing AC platforms, follow the requirements of the National Electrical Code ANSI/NFPA 70, where applicable.

The platform is powered-up when the power cable is connected between the platform and the power source.

⚠ CAUTION: Always disconnect the power cable before you service the power supply slots. The platform has multiple power cords. Before servicing, ensure that all power cords are disconnected.

⚠ CAUTION: Use the power supply cable as the main disconnect device. Ensure that the socket-outlet is located/installed near the equipment and is easily accessible.

Storing components

If you do not install the VEP4600 and components immediately, properly store the platform and all optional components following these guidelines:

- Storage location temperature must remain constant. The storage range is from -40°C to 70°C (-40°F to 158°F).
- Store on a dry surface or floor, away from direct sunlight, heat, and air conditioning ducts.
- Store in a dust-free environment.

i **NOTE:** ESD damage can occur when components are mishandled. Always wear an ESD-preventive wrist or heel ground strap when handling the platform and its accessories. After you remove the original packaging, place the VEP4600 and its components on an anti-static surface.

VEP4600 installation

To install VEP4600, complete the installation procedures in the order presented in this section.

Always handle the platform and its components with care. Avoid dropping the platform or any field replaceable units (FRUs).

NOTE: ESD damage can occur if components are mishandled. Always wear an ESD-preventive wrist or heel ground strap when handling the platform and its components. As with all electrical devices of this type, take all the necessary safety precautions to prevent injury when installing this platform.

Topics:

- [Unpack](#)
- [VEP Expansion Card installation](#)
- [Ground cable](#)
- [Rack or cabinet installation](#)
- [Two-post installation](#)
- [Four-post installation](#)
- [Optics installation](#)
- [Platform power-up](#)

Unpack

NOTE: Before unpacking the platform, inspect the container and immediately report any evidence of damage.

When unpacking VEP4600, make sure that the following items are included:

- One VEP4600
 - One or two AC PSUs, depending on the configuration

- Four or five AC normal fan units, depending on the configuration
 - One RJ-45 to DB-9 female cable
 - Two-post rail kit, no tools required
 - One or two country- and region-specific AC power cords, depending on the configuration
 - Ground lug kit (included in the accessories box)
 - *VEP4600 Setup Guide*
 - *Safety and Regulatory Information*
 - *Warranty and Support Information*
- 1 Place the container on a clean, flat surface and cut all straps securing the container.
 - 2 Open the container.
 - 3 Carefully remove the platform from the container and place it on a secure and clean surface.
 - 4 Remove all packing material.
 - 5 Inspect the product and accessories for damage.

VEP Expansion Card installation

⚠ WARNING: Customers are not to attempt installing Virtual Edge Platform (VEP) 4600 expansion cards. A Dell EMC Certified technician must perform this installation.

⚠ CAUTION: The mezzanine cards are intended for professional installation only.

⚠ CAUTION: Professional installation instructions: This product is designed for specific applications and needs to be installed by qualified personnel with RF and regulatory related knowledge. The general user shall not attempt to install or change the setting.

Ground cable

To attach a ground cable to the switch, use the included two M3 ground lug bracket screws. The switch ships with the M3 ground lug bracket screws attached.

ⓘ NOTE: For AC-powered platforms, although the third conductor of the AC power cord provides a ground path, Dell EMC recommends grounding your platform with a dedicated ground wire.

The ground cable is not included. To properly ground the platform, Dell EMC recommends a one- or two-hole lug, M3 hole size. The ground lug must be a UL-recognized, crimp-type lug.

⚠ CAUTION: Grounding conductors *must* be made of copper. Do not use aluminum conductors.

ⓘ NOTE: Coat the one-hole lug with an anti-oxidant compound before crimping. Also, bring any unplated mating surfaces to a shiny finish and coat with an anti-oxidant before mating. Plated mating surfaces must be clean and free from contamination.

ⓘ NOTE: The rack installation ears are not suitable for grounding.

Before you install the switch into the dual-tray:

- 1 Cut the ground cable (not included) to the desired length. The cable length must facilitate proper operation of the fault interrupt circuits. Use the shortest cable route allowable.
- 2 Unscrew the two attached M3 screws and set aside.
- 3 Attach the ground lug and bracket to the switch using the M3 screws.

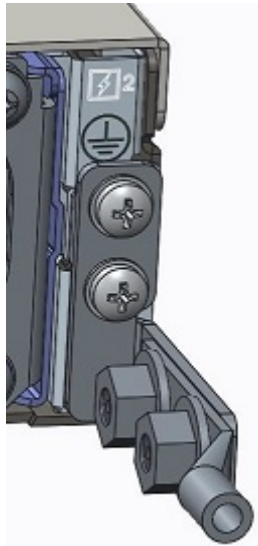

Figure 2. VEP4600 ground lug attached

- 4 Attach the other end of the ground cable to a suitable ground point such as the rack or cabinet.

Rack or cabinet installation

You may either place the platform on a rack shelf or mount the platform directly into a 19" wide, EIA-310- E-compliant rack.

The platform includes two-post rail assemblies.

⚠ WARNING: This guide is a condensed reference. Read the safety instructions in your *Safety, Environmental, and Regulatory* information booklet before you begin.

ⓘ NOTE: The illustrations in this section are not intended to represent a specific platform.

ⓘ NOTE: Do not the use the mounted two-post rails as a shelf or a workplace.

Rack mount safety considerations

- Rack loading—Overloading or uneven loading of racks may result in shelf or rack failure, possibly damaging the equipment and causing personal injury. Stabilize racks in a permanent location before loading begins. Mount the components starting at the bottom of the rack, then work to the top. Do not exceed your rack's load rating.
- Power considerations—Connect only to the power source specified on the unit. When you install multiple electrical components in a rack, ensure that the total component power ratings do not exceed the circuit capabilities. Overloaded power sources and extension cords present fire and shock hazards.
- Elevated ambient temperature—If you install the platform in a closed rack assembly, the operating temperature of the rack environment may be greater than the room ambient temperature. Use care not to exceed the 45°C (113°F) maximum ambient temperature of the platform.
- Reduced air flow—Do not compromise the amount of airflow required for safe operation of the equipment. Install the equipment in the rack so that the equipment constantly has the correct amount of airflow surrounding it.
- Reliable earthing—Maintain reliable earthing of rack-mounted equipment. Pay particular attention to the supply connections other than the direct connections to the branch circuit, for example; use of power strips.
- Do not mount the equipment with the fan panel facing in the downward position.

Two-post installation

To easily configure your rack for installation of the VEP4600, use the two-post rack mounting system provided. To complete this installation, supply four rack-mounting screws.

① **NOTE:** To be NEBS-compliant, you must install the VEP4600 in a four-post rack.

To begin installation, separate each rail assembly by sliding the inside rail out of the outside rail.

① **NOTE:** For more installation instructions, see the installation labels attached to the rail assembly.

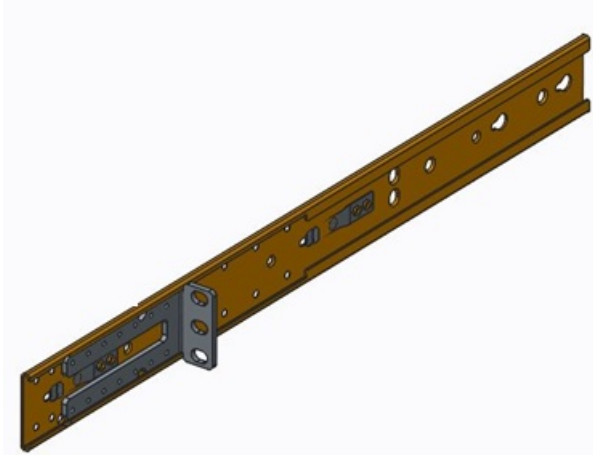

Figure 3. Two-post rail

1U front-rack installation

- 1 Attach the inner platform rails to the VEP4600.
Line up the half-holes on the rail with the mounting heads on the platforms and attach the rail to the platform. Slide the rail back until it locks into place.

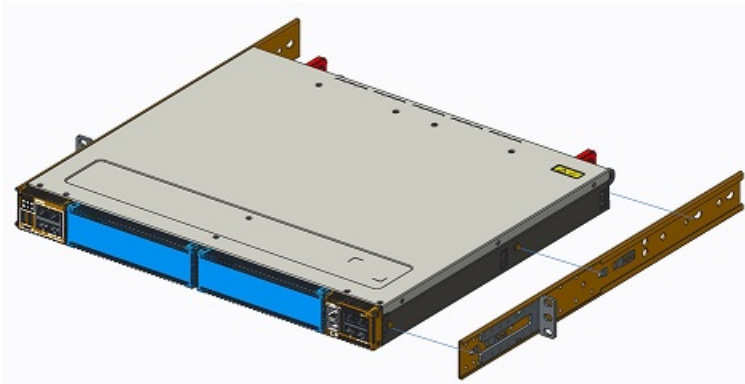

Figure 4. Platform rail attachment

- 2 Repeat on the other side of the platform.
- 3 Attach the outer platform rails to the two-post rack rails using two user-supplied screws on each side.
- 4 After you install both rails, line up the platform rails with the installed rack rails. Slide the platform in until it is flush with the front of rack.
About three inches before you fully insert your platform, the rail locking feature engages to keep the platform from inadvertently sliding out and falling.

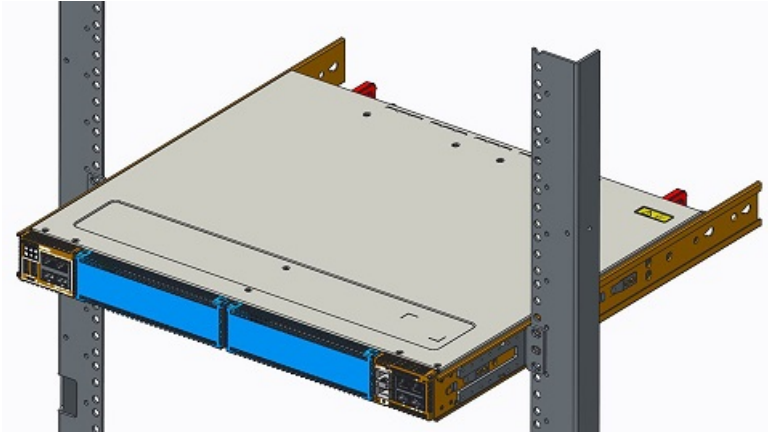

Figure 5. Platform two-post installed

① **NOTE: Do not use the mounted rails as a shelf or a workplace.**

To remove the platform, unscrew the rack-mounting screws and slide the platform forward.

Four-post installation

To complete this installation, supply eight rack mounting screws.

① **NOTE: The following installation instructions are for NEBS-compliant platforms.**

① **NOTE: For more installation instructions, see the installation labels attached to the rail assembly.**

- 1 Separate each rail assembly by sliding the inside rail out of the outside rail.
- 2 Attach the inner platform rails to the VEP4600.
Line up the half-holes on the rail with the mounting heads on the platforms and attach the rail to the platform. Slide the rail back until it locks into place.

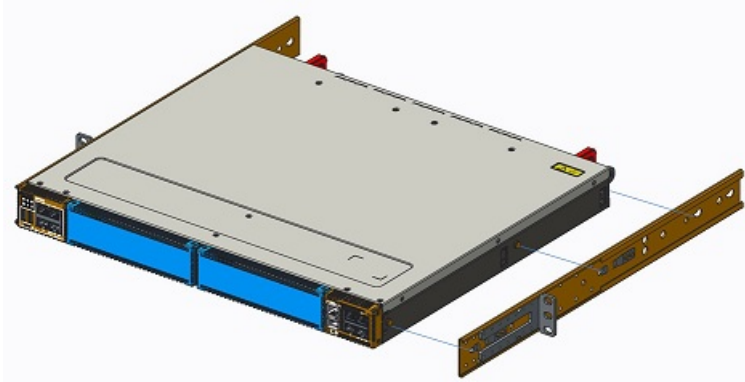

Figure 6. Platform rail attachment

- 3 Repeat on the other side of the platform.
- 4 Attach the platform rails to the four-post rack rails using two user-supplied screws on each side.

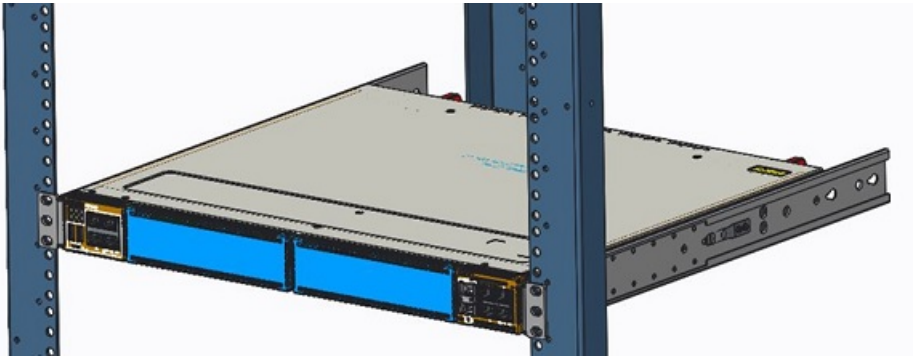

Figure 7. Platform four-post front installed

- 5 Slide the rear platform rail from the back to the front bracket. Secure with two user-supplied screws on each side.

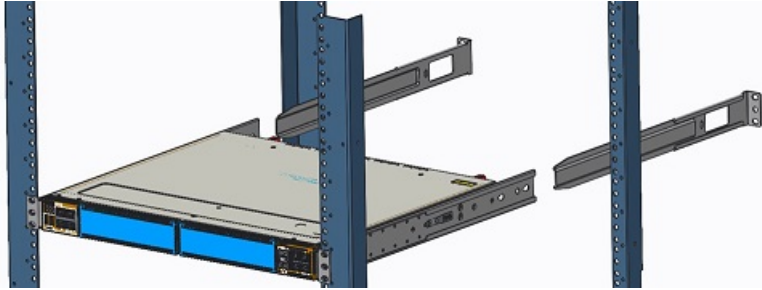

Figure 8. Platform four-post rear installed

About three inches before you fully insert your platform, the rail locking feature engages to keep the platform from inadvertently sliding out and falling.

To remove the platform, unscrew the rack-mounting screws and slide the platform forward.

Optics installation

⚠ WARNING: When working with optical fibers, follow all warning labels and always wear eye protection. Never look directly into the end of a terminated or unterminated fiber or connector as it may cause eye damage.

- 1 Position the optic so it is in the correct position.
The optic has a key that prevents it from being inserted incorrectly.
- 2 Insert the optic into the port until it gently snaps into place.

ⓘ NOTE: When you cable the ports, be sure not to interfere with the airflow from the small vent holes above and below the ports.

Optics removal

Remove an optic by pushing the tab on the optic and sliding the optic from the port.

When removing optics with direct attach cables (DACs) from the port, pull the release tab firmly and steadily. Before pulling the release tab, you may need to gently push the optic into the port to ensure that it is seated properly. Do not jerk or tug repeatedly on the tab.

Platform power-up

Supply power to the VEP4600 after you mount it in a rack or cabinet.

Reinspect your platform before power-up. Verify the following:

- The equipment is properly secured to the rack. Dell EMC recommends properly grounding the platform.
- The ambient temperature around the unit, which may be higher than the room temperature, is within the limits specified for the VEP4600, see [Specifications](#).
- There is sufficient airflow around the unit.
- The input circuits are correctly sized for the loads and that you use sufficient overcurrent protection devices.
- All protective covers are in place.
- Blank panels are installed if you do not install optional modules.

⚠ CAUTION: Do not power up the platform if you did not install a fan module.

ⓘ NOTE: A US AC power cable is included for powering up an AC power supply. You must order all other power cables separately.

ⓘ NOTE: ESD damage can occur if components are mishandled. Always wear an ESD-preventive wrist or heel ground strap when handling the platform and its components.

Power up sequence

When the platform powers up, the fans immediately come on at high speed. The fan speed slows as the platform continues to boot up.

Specifications

This section lists the VEP4600 specifications.

⚠ CAUTION: Operate the product at an ambient temperature not higher than 0°C to 45°C (32°F to 113°F).

⚠ CAUTION: Lithium Battery Caution: There is a danger of explosion if the battery is incorrectly replaced. Replace only with same or equivalent type of battery. Dispose of the batteries according to the manufacturer's instructions.

ℹ NOTE: For RoHS information, see [Restricted Material Compliance](#).

Topics:

- [Chassis physical design](#)
- [VEP4600 Expansion Card antennas](#)
- [Agency compliance](#)

Chassis physical design

Table 1. Chassis physical design

Parameter	Specifications
Height	1.75 inches (44 mm)
Width	17.1 inches (434 mm)
Depth	15 inches (381 mm)
	PSU/fan tray handle: 1.57 inches (40 mm)
Chassis weight with factory-installed components	<ul style="list-style-type: none"> · 13.75 lbs (6.24 kg) (1 PSU and 4 fans) · 13.90 lbs (6.30 kg) (1 PSUs and 5 fans)

Parameter	Specifications
Rack clearance required	<ul style="list-style-type: none"> 15.75 lbs (7.14 kg) (2 PSUs and 5 fans) Front: 5 inches (12.7 cm) Back: 5 inches (12.7 cm)

Table 2. Environmental parameters

Parameter	Specifications
Operating temperature	0°C to 45°C (23°F to 113°F) continuously -5°C to 45°C (23°F to 113°F) short term Short term is </= 1% of operational hours per year. <div style="border-left: 1px solid black; padding-left: 10px;"> <p>NOTE: Reduce maximum temperature by 1°C/125 meters (1°F/228 feet) above 950 meters (3,117 feet).</p> </div>
Operating humidity	5% to 90% (RH), non-condensing
Storage temperature	-40° to 70°C (-40° to 158°F)
Storage humidity	5% to 90%, non-condensing
Maximum thermal output	500 W = 1706 BTU/Hr
Maximum operational altitude	10,000 feet (3,048 meters)
Maximum non-operational altitude	35,000 feet (10,668 meters)
Shock	Dell EMC Spec SV0115

Table 3. AC power requirements

Parameter	Specifications
Power supply	100–240 VAC 50/60 Hz
Maximum current draw per system	5A/4.17A at 100/120V AC 2.5A/2.1A at 200/240V AC
Maximum power consumption*	<ul style="list-style-type: none">• 5-fan 16-core CPU: 300W• 4-fan 8-core CPU: 230W• 4-fan 4-core CPU: 220W
Typical power consumption*	240W

Table 4. Expansion card AC power requirements

Parameter	Specifications
Maximum power consumption*	0.9 Watt rNDC Carrier 16 Watt LTE 15 Watt WIFI
Typical power consumption*	0.37 Watt rNDC Carrier 8 Watt LTE 7 Watt WIFI

rNDC power can be found in their respective datasheets.

*For the most current power consumption specifications, see the Installation Guide at www.Dell.com/support.

VEP4600 Expansion Card antennas

The following explains the best antenna position for maximum signal reception.

 **CAUTION: The external antennas are certified for indoor use only.**

- △ **CAUTION:** The use of external signal amplifiers in-line with the transceiver antennas is strictly prohibited.
- △ **CAUTION:** The product shall be installed in a location where the radiating antenna is kept 20 cm from nearby persons in its normal operational condition to meet global regulatory RF exposure requirements.
- △ **CAUTION:** Use only the antenna(s) which have been approved by the applicant. Non-approved antenna(s) may produce unwanted spurious or excessive RF transmitting power which may lead to a violation of FCC/IC limits and is prohibited.
- △ **CAUTION:** The certified LTE antennas provided with this product are dipole type with a maximum gain per the following table.
- △ **CAUTION:** The certified Wi-Fi antennas provided with this product are dipole type with a maximum gain per the following table.
- ⓘ **NOTE:** The use of a third party GPS active antenna is permitted if it meets the characteristics in the Antenna specifications table below.

Table 5. Antenna specifications

Antenna specifications			
WIFI Antenna			
Frequency	2400 - 2500 MHz	5150 - 5850 MHz	
Gain	2 dBi	2.5 dBi	
BLE Antenna			
Frequency	2400 - 2500 MHz		
Gain	2 dBi		
LTE Antenna			
Frequency	700 MHz	1710 MHz	2500 MHz
Gain	1 dBi	1.75 dBi	3.5 dBi
GPS Antenna			
Frequency	1560 - 1606 MHz		

Antenna specifications

Gain $-7 \text{ dBi} \leq \text{Gain} \leq 1 \text{ dBi}$

Whip antennas on the WiFi and LTE Cards

All antennas should be articulated to upright position for optimal performance. There should not be large metal objects within a three foot radius of the antenna.

- 1 WiFi 1
- 2 BT/BLE
- 3 WiFi 2

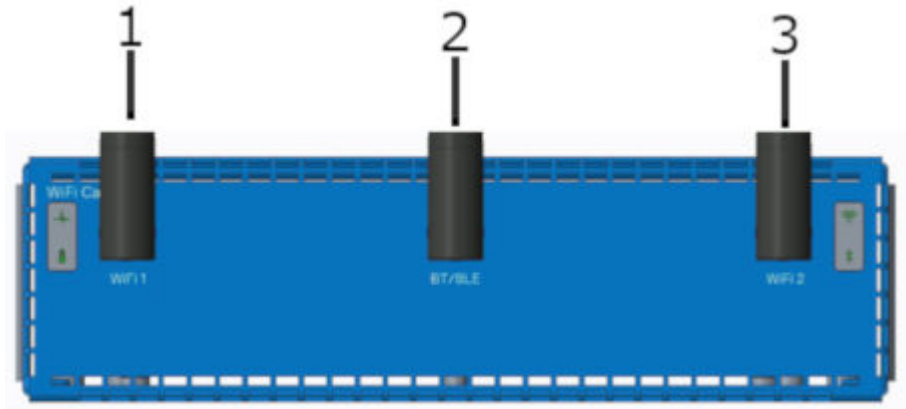

VEP4600 WiFi Card whip antennas

- 1 LTE 1
- 2 LTE 2

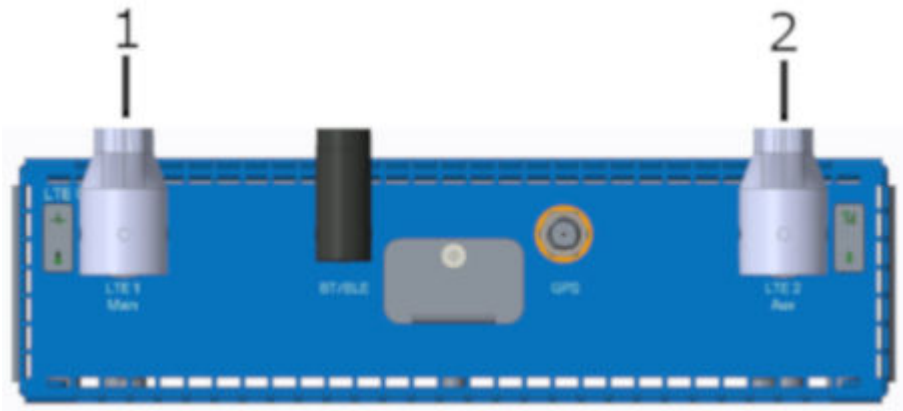

VEP4600 LTE Card whip antennas

GPS antenna on the VEP4600 LTE Card

NOTE: Users are allowed to source a third party active antenna with net gain within the range of +1 and -7 dBi.

Attach the three foot antenna cable to the GPS SMA connector (call-out 1) on the front panel of the card.

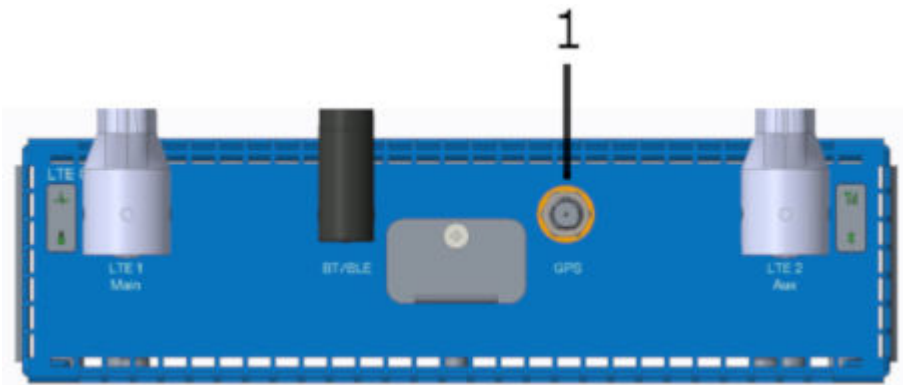

VEP4600 LTE card GPS SMA connector (call-out 1)

Mount the GPS antenna within 10 feet of a window for best reception.



VEP4600 LTE card GPS antenna

Agency compliance

The VEP4600 is designed to comply with the following safety and agency requirements:

USA Federal Communications Commission statement

- △ **CAUTION:** The use of external signal amplifiers in-line with the transceiver antennas is strictly prohibited.
- △ **CAUTION:** Use only the antenna(s) which have been approved by the applicant. Non-approved antenna(s) may produce unwanted spurious or excessive RF transmitting power which may lead to a violation of FCC/IC limits and is prohibited.

This device complies with Part 15 of the FCC Rules. Operation is subject to the following two conditions:

- 1) This device may not cause harmful interference, and (2) this device must accept any interference received, including interference that may cause undesired operation.

This equipment has been tested and found to comply with the limits for a Class A digital device, pursuant to Part 15 of the FCC Rules.

These limits are designed to provide reasonable protection against harmful interference in a residential installation. This equipment generates, uses and can radiate radio frequency energy and, if not installed and used in accordance with the instructions, may cause harmful interference to radio communications. However, there is no guarantee that interference will not occur in a particular installation. If this equipment does cause harmful interference to radio or television reception, which can be determined by turning the equipment off and on, the user is encouraged to try to correct the interference by one of the following measures.

Reorient or relocate the receiving antenna.

Increase the separation between the equipment and receiver.

Connect the equipment into an outlet on a circuit different from that to which the receiver is connected.

Consult the dealer or an experienced radio/TV technician for help.

FCC Caution:

Any changes or modifications not expressly approved by the party responsible for compliance could void the user's authority to operate this equipment.

This transmitter must not be co-located or operating in conjunction with any other antenna or transmitter.

Radiation Exposure Statement:

This equipment complies with FCC radiation exposure limits set forth for an uncontrolled environment. This equipment should be installed and operated with minimum distance 20cm between the radiator & your body.

i NOTE: The country code selection is for non-US model only and is not available to all US model. Per FCC regulation, all WiFi product marketed in US must fixed to US operation channels only.

Industry Canada Statement

- △ **CAUTION: The use of external signal amplifiers in-line with the transceiver antennas is strictly prohibited.**
- △ **CAUTION: Use only the antenna(s) which have been approved by the applicant. Non-approved antenna(s) may produce unwanted spurious or excessive RF transmitting power which may lead to a violation of FCC/IC limits and is prohibited.**
- △ **CAUTION: L'utilisation d'amplificateurs de signal externes en ligne avec les antennes de l'émetteur-récepteur est strictement interdite.**
- △ **CAUTION: Utilisez uniquement les antennes approuvées par le demandeur. Une ou plusieurs antennes non approuvées peuvent produire une puissance de transmission RF parasite ou excessive, susceptible d'entraîner une violation des limites FCC / IC et est interdite.**

This device complies with Industry Canada license-exempt RSS standard(s). Operation is subject to the following two conditions:

- 1 This device may not cause interference, and
- 2 This device must accept any interference, including interference that may cause undesired operation of the device.

Le présent appareil est conforme aux CNR d'Industrie Canada applicables aux appareils radio exempts de licence. L'exploitation est autorisée aux deux conditions suivantes:

- 1 l'appareil ne doit pas produire de brouillage, et
- 2 l'utilisateur de l'appareil doit accepter tout brouillage radioélectrique subi, même si le brouillage est susceptible d'en compromettre le fonctionnement.

This Class A digital apparatus complies with Canadian ICES-003.

Cet appareil numérique de la classe A est conforme à la norme NMB-003 du Canada.

This device complies with RSS-GEN, RSS-210, RSS-130, RSS-132, RSS-133, RSS-139, RSS-195, RSS-199 & RSS-247 of Industry Canada. Operation is subject to the condition that this device does not cause harmful interference.

Cet appareil est conforme à la norme RSS-GEN, RSS-210, RSS-130, RSS-132, RSS-133, RSS-139, RSS-195, RSS-199 & RSS-247 d'Industrie Canada. L'opération est soumise à la condition que cet appareil ne provoque aucune interférence nuisible.

This device and its antenna(s) must not be co-located or operating in conjunction with any other antenna or transmitter, except tested built-in radios.

Cet appareil et son antenne ne doivent pas être situés ou fonctionner en conjonction avec une autre antenne ou un autre émetteur, exception faites des radios intégrées qui ont été testées.

The County Code Selection feature is disabled for products marketed in the US/Canada.

La fonction de sélection de l'indicatif du pays est désactivée pour les produits commercialisés aux États-Unis et au Canada.

Radiation Exposure Statement: This equipment complies with IC radiation exposure limits set forth for an uncontrolled environment. This equipment should be installed and operated with minimum distance 20cm between the radiator & your body.

Déclaration d'exposition aux radiations: Cet équipement est conforme aux limites d'exposition aux rayonnements IC établies pour un environnement non contrôlé. Cet équipement doit être installé et utilisé avec un minimum de 20 cm de distance entre la source de rayonnement et votre corps.

Caution:

- 1 The device for operation in the band 5150-5250 MHz is only for indoor use to reduce the potential for harmful interference to co-channel mobile satellite systems;
- 2 The maximum antenna gain permitted for devices in the bands 5250-5350 MHz and 5470-5725 MHz shall comply with the eirp limit; and
- 3 The maximum antenna gain permitted for devices in the band 5725-5825 MHz shall comply with the eirp limits specified for point-to-point and non point-to-point operation as appropriate.
- 4 The worst-case tilt angle(s) necessary to remain compliant with the eirp elevation mask requirement set forth in Section 6.2.2(3) shall be clearly indicated.

- 5 Users should also be advised that high-power radars are allocated as primary users (i.e. priority users) of the bands 5250-5350 MHz and 5650-5850 MHz and that these radars could cause interference and/or damage to LE-LAN devices.

Avvertissement:

- 1 Les dispositifs fonctionnant dans la bande 5150-5250 MHz sont réservés uniquement pour une utilisation à l'intérieur afin de réduire les risques de brouillage préjudiciable aux systèmes de satellites mobiles utilisant les mêmes canaux;
- 2 Le gain maximal d'antenne permis pour les dispositifs utilisant les bandes 5250-5350 MHz et 5470-5725 MHz doit se conformer à la limite de p.i.r.e.;
- 3 Le gain maximal d'antenne permis (pour les dispositifs utilisant la bande 5725-5825 MHz) doit se conformer à la limite de p.i.r.e. spécifiée pour l'exploitation point à point et non point à point, selon le cas.
- 4 Les pires angles d'inclinaison nécessaires pour rester conforme à l'exigence de la p.i.r.e. applicable au masque d'élévation, et énoncée à la section 6.2.2 3), doivent être clairement indiqués.
- 5 De plus, les utilisateurs devraient aussi être avisés que les utilisateurs de radars de haute puissance sont désignés utilisateurs principaux (c.-à-d., qu'ils ont la priorité) pour les bandes 5250-5350 MHz et 5650-5850 MHz et que ces radars pourraient causer du brouillage et/ou des dommages aux dispositifs LAN-EL.

Brasil – Aviso da Anatel

Este equipamento opera em caráter secundário, isto é, não tem direito a proteção contra interferência prejudicial, mesmo de estações do mesmo tipo, e não pode causar interferência a sistemas operando em caráter primário.

Certification pending.

European Union EMC directive conformance statement

This product is in conformity with the protection requirements of EU Council Directive 2004/108/EC on the approximation of the laws of the Member States relating to electromagnetic compatibility. Dell EMC cannot accept responsibility for any failure to satisfy the protection requirements resulting from a non-recommended modification of this product, including the fitting of non-Dell EMC option cards.

This product has been tested and found to comply with the limits for Class A Information Technology Equipment according to CISPR 32/CISPR34 and EN55032 / EN55034. The limits for Class A equipment were derived for commercial and industrial environments to provide reasonable protection against interference with licensed communication equipment.

⚠ WARNING: This is a Class A product. In a domestic environment, this device may cause radio interference, in which case, you may be required to take adequate measures.

European Community Contact

Dell EMC, EMEA - Central

Dahlienweg 19

66265 Heusweiler

Germany

Tel: +49 172 6802630

Email: EMEA Central Sales

Japan VCCI compliance for class A equipment

この装置は、情報処理装置等電波障害自主規制協議会（VCCI）の基準に基づくクラスA情報技術装置です。この装置を家庭環境で使用すると電波妨害を引き起こすことがあります。この場合には使用者が適切な対策を講ずるよう要求されることがあります。

Japan: VCCI compliance for class A equipment

This is Class A product based on the standard of the Voluntary Control Council For Interference by Information Technology Equipment (VCCI). If this equipment is used in a domestic environment, radio disturbance may arise. When such trouble occurs, the user may be required to take corrective actions.

⚠ WARNING: Use the AC power cords with Dell EMC equipment only. Do not use Dell EMC AC power cords with any unauthorized hardware.

本製品と同梱いたしております電源コードセットは、本製品専用です。本電源コードセットは、本製品以外の製品ならびに他の用途でご使用いただくことは出来ません。製品本体には同梱された電源コードセットを使用し、他製品の電源コードセットを使用しないで下さい。

Japan: warning label

WiFi+BT compliance certificate

電波法により5GHz帯は屋内使用に限ります。

Japanese WiFi, Bluetooth compliance certificate

BTE compliance certificate

タブレットコンピュータの使用目的オリエンテーション

使用者の体に対してタブレットコンピュータ画面側を抱き抱えることは、タフな方法ではありません。

WWAN トランスミッタがアクティブであるために、使用者の身体からタブレットを 20 センチ以上の距離を確保してください。

製品の他の 5 つの側面は、デルの特徴としてタブレットの使用可能な向きを肌体に密着しながら使用することができます。

ありがとうございます。

Japanese BTE compliance certificate

Korean certification of compliance

<p>A급 기기 (업무용 방송통신기자재)</p>	<p>이 기기는 업무용(A급) 전자파적합기기로서 판매자 또는 사용자는 이 점을 주의하시기 바라며, 가정외의 지역에서 사용하는 것을 목적으로 합니다.</p>
--------------------------------	--

Korean certification of compliance

	 <i>[equipment type]</i>
<p>품명(Product Name)</p>	<p>Ethernet Switch</p>
<p>모델명(Model)</p>	<p><i>[model number]</i></p>
<p>신청인(Applicant)</p>	<p>Dell Technologies</p>
<p>제조사(Manufacturer)</p>	<p><i>[Manufacturer]</i></p>
<p>제조년월(Manufacturing Date)</p>	<p><i>[date]</i></p>
<p>제조국(Country of Origin)</p>	<p>China</p>

Figure 9. Korean package label

Radio compliance certificate

Korea (Korean warning statement is only required for devices contain 2400~2483 and/or 5725~5825 MHz radios)

해당 무선설비는 운용 중 전파혼신 가능성이 있음

Korean radio compliance certificate

Mexican certification of compliance

Mexican compliance.

La operación de este equipo está sujeta a las siguientes dos condiciones:

- 1 es posible que este equipo o dispositivo no cause interferencia perjudicial y
- 2 este equipo o dispositivo debe aceptar cualquier interferencia, incluyendo la que pueda causar su operación no deseada.

Taiwanese certification of compliance

Taiwanese radio compliance.

台灣: 國家通訊傳播委員會

低功率電波輻射性電機管理辦法

第十二條經型式認證合格之低功率射頻電機，非經許可，公司、商號或使用者均不得擅自變更頻率、加大功率或變更原設計之特性及功能。

第十四條低功率射頻電機之使用不得影響飛航安全及干擾合法通信；經發

現有干擾現象時，應立即停用，並改善至無干擾時方得繼續使用。前項合法通信，指依電信法規定作業之

無線電通信。低功率射頻電機須忍受合法通信或工業、科學及醫療用電波輻射性電機設備之干擾。

在 5.25-5.35 兆赫頻帶內操作之無線資訊傳輸設備，限於室內使用。

Taiwanese radio compliance certificate

Singapore certification of compliance

Singaporean radio compliance.

Complies with IMDA Standards

XXXXXX (xxxxxx = Dealer Code)

Certification pending.

Support

The support site provides documents and tools to help you effectively use your equipment and mitigate network outages. Through the support site you can obtain technical information, access software upgrades and patches, download available management software, and manage your open cases. The support site provides integrated, secure access to these services.

To access the support site, go to www.dell.com/support/. To display information in your language, scroll down to the bottom of the web page and select your country from the drop-down menu.

- To obtain product-specific information, enter the 7-character service tag, known as a luggage tag, or 11-digit express service code of your platform and click **Submit**.
To view the chassis service tag or express service code, pull out the tag on the upper-right side of the platform.
- To receive more technical support, click **Contact Us**. On the **Contact Information** web page, click **Technical Support**.

To access platform documentation, go to www.dell.com/manuals/.

To search for drivers and downloads, go to www.dell.com/drivers/.

To participate in community blogs and forums, go to www.dell.com/community.