



SCv360 Expansion Enclosure

Getting Started Guide

Notes, Cautions, and Warnings

-  **NOTE:** A NOTE indicates important information that helps you make better use of your product.
-  **CAUTION:** A CAUTION indicates either potential damage to hardware or loss of data and tells you how to avoid the problem.
-  **WARNING:** A WARNING indicates a potential for property damage, personal injury, or death.

© 2017 – 2018 Dell Inc. or its subsidiaries. All rights reserved. Dell, EMC, and other trademarks are trademarks of Dell Inc. or its subsidiaries. Other trademarks may be trademarks of their respective owners.

Setting Up the Expansion Enclosure

Consider the following best practices when setting up an SCv360 expansion enclosure:

- An SCv360 expansion enclosure is shipped with two SAS cables. Two more SAS cables are needed to connect an SCv360 expansion enclosure to a storage system in a high-availability environment. The SAS cables can be ordered in lengths of three, four, or five meters.
- Before connecting any cables between the expansion enclosure and storage system, physically label each port and connector.
- Always follow proper power-up and power-down procedures when cycling power across the network. Verify that critical network components are on separate power circuits.

Topics:

- [Other Information You May Need](#)
- [Installation and Configuration](#)
- [NOM Information \(Mexico Only\)](#)
- [Technical Specifications](#)

Other Information You May Need

To install the expansion enclosure, you may need the following additional information:

- *Dell SCv360 Expansion Enclosure Owner's Manual*
Provides information about an SCv360 expansion enclosure, such as hardware features, replacing hardware components, and technical specifications.
- *Dell SCv3000 and SCv3020 Storage System Deployment Guide*
Provides information about an SCv3000 series storage system, such as cabling the hardware components and configuring the storage system using Storage Manager.
- *Dell Storage Manager Administrator's Guide*
Provides instructions for using the Data Collector Manager and the Dell Storage Manager Client.

Installation and Configuration

Before you begin the installation, make sure that the site where you plan to install the expansion enclosure has standard power from an independent source or a rack power distribution unit (PDU) with a UPS.

Safety Precautions

Always follow these safety precautions to avoid injury and damage to Storage Center equipment.

If equipment described in this guide is used in a manner not specified by Dell, the protection provided by the equipment could be impaired. For your safety and protection, observe the rules described in the following sections.

NOTE: See the safety and regulatory information that shipped with each Storage Center component. Warranty information is included as a separate document.

Installation Safety Precautions

Follow these safety precautions when installing an SCv360 expansion enclosure:



Caution

Equipment exceeds 90 kg (200 lb). Use appropriate lifting methods when installing an SCv360 expansion enclosure.

- You can install the expansion enclosure chassis without using a mechanical lift if you remove the drives, cooling fans, power supply units (PSUs), and enclosure management modules (EMMs) from the chassis before installing it.

You must use a mechanical lift to install the expansion enclosure chassis if you do not remove the drives, cooling fans, PSUs, and EMMs from the chassis.

- Dell recommends that only individuals with rack-mounting experience install an SCv360 expansion enclosure in a rack.
- When installing multiple expansion enclosures in a rack, fill the rack from the bottom up and empty the rack from the top down.

- The rack construction must support the total weight of the installed expansion enclosures. The design should incorporate stabilizing features suitable to prevent the rack from tipping or being pushed over during installation or in normal use.
- To prevent the rack from tipping, slide only one expansion enclosure out of the rack at a time.
- Make sure that the expansion enclosure is always fully grounded to prevent damage from electrostatic discharge.
- When handling the expansion enclosure components, use an electrostatic wrist guard or a similar form of protection.

Unpacking Storage Center Equipment

Unpack the expansion enclosure and identify the items in your shipment.

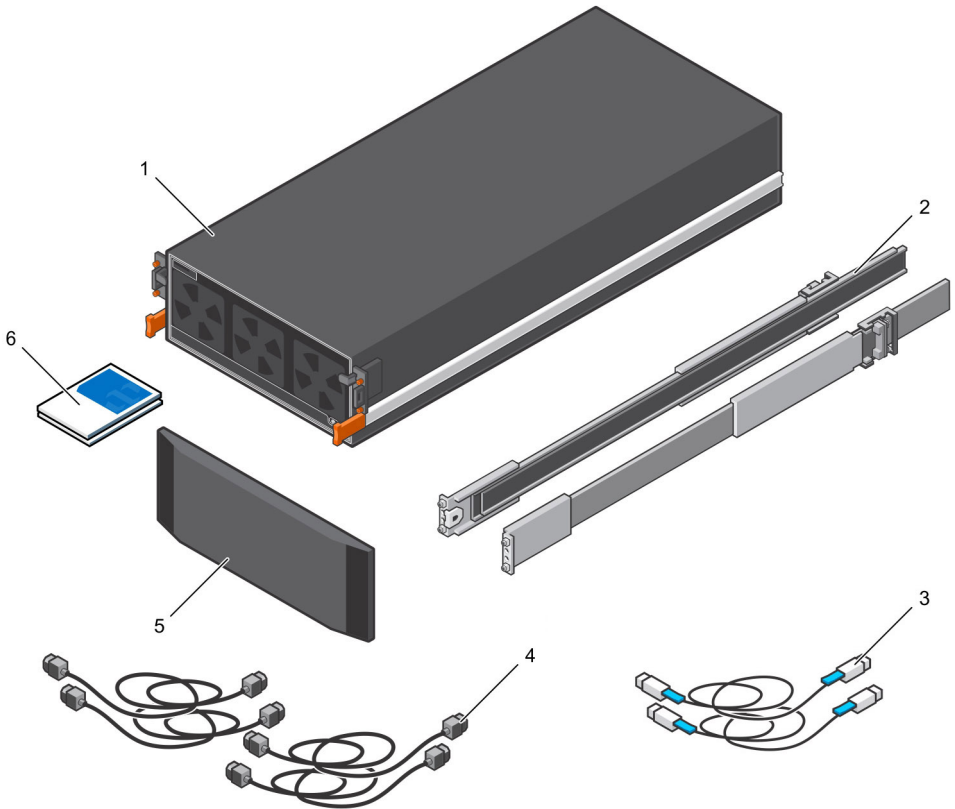

Figure 1. Expansion Enclosure Components

- | | | | |
|---|------------------------|---|------------------|
| 1 | Expansion enclosure | 2 | Rack rails (2) |
| 3 | Mini-SAS HD cables (2) | 4 | Power cables (4) |
| 5 | Front bezel (Optional) | 6 | Documentation |

Determine the Mounting Location

Determine where to mount the SCv360 expansion enclosure in the rack.

- 1 Identify a location in the rack with 4U of space for the expansion enclosure.

⚠ WARNING: If you plan to install the expansion enclosure above the lower 20U of a rack, use a mechanical lift to avoid injury.

- 2 If you plan to install the 1U cable management tray below the expansion enclosure, identify a location in the rack with 5U of space for the expansion enclosure and cable management tray.

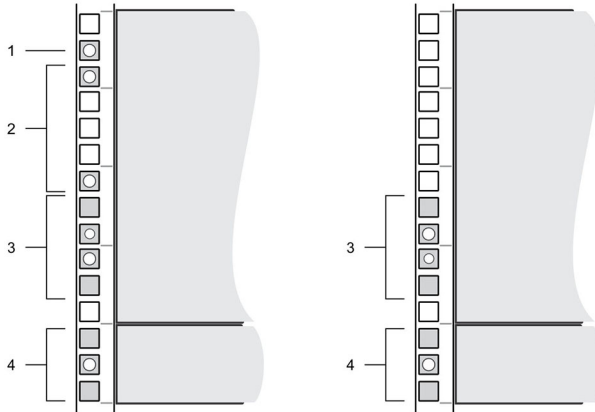

Figure 2. Mounting Location from Front and Back of Rack

- | | | | |
|---|--|---|--|
| 1 | Location for the clip nuts to secure the top cover | 2 | Location for the clip nuts to secure the expansion enclosure |
| 3 | Location for the expansion enclosure rack rails | 4 | Location for the 1U cable management tray rails |

SCv360 Expansion Enclosure Hardware Mounting Kit

The SCv360 expansion enclosure ships with the following hardware mounting kits:

Table 1. Standard Rail Kit

Part	Part Number	Description
	106-002-452	M5-0.8 x 10 mm Phillips pan-head SEMS screw (Quantity: 2) Used to secure the expansion enclosure rails to the front of the rack
	106-002-453	M5-0.8 x 16 mm Phillips pan-head SEMS screw (Quantity: 2) Used to secure the expansion enclosure rails to the back of the rack
	106-569-307	M5-0.8 clip nut (Quantity: 6) Used to secure the expansion enclosure chassis and top cover to a rack without threaded holes

Table 2. Universal Rail Kit



Part	Part Number	Description
	036-028-016	3.8 mm alignment pin (Quantity: 8) Replacement alignment pin used to mount rails in racks that have M5, #10-32, or #12-24 threaded holes
	036-028-017	4.8 mm alignment pin (Quantity: 8) Replacement alignment pin used to mount rails in racks that have M6 threaded holes
	036-028-018	M4-0.7 x 10 mm flathead screw (Quantity: 4) Used to secure expansion enclosure rails to a rack with threaded holes

Table 3. Expansion Enclosure Chassis Handle Kit

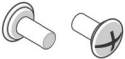
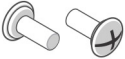
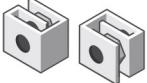
Part	Part Number	Description
	036-034-003	Expansion enclosure chassis handle (Quantity: 4) Used to lift the expansion enclosure chassis onto a mechanical lift and mount it in a rack

Table 4. Top Cover and Expansion Enclosure Chassis Kit

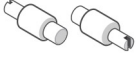
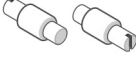





Part	Part Number	Description
	036-032-010	M5-0.8 x 12 mm truss head Phillips screw with nylon patch (Quantity: 2) Used to secure the top cover to a standard Dell rack or a third-party rack with non-threaded holes
	036-032-011	M6-1.0 x 12 mm truss head Phillips screw with nylon patch (Quantity: 6) Used to secure the expansion enclosure chassis to a nonstandard rack with M6 threaded holes
	036-032-009	#10-32 x 1/2 in. truss head Phillips screw with nylon patch (Quantity: 6) Used to secure the expansion enclosure chassis to a nonstandard rack with #10-32 threaded holes
	036-032-012	#12-24 x 1/2 in. truss head Phillips screw with nylon patch (Quantity: 6) Used to secure the expansion enclosure chassis to a nonstandard rack with #12-24 threaded holes

Table 5. 1U Management Tray Rail Kit

Part	Part Number	Description
	036-034-012	#8-32 x 3/4 in. Phillips screw (Quantity: 5)

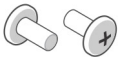
Part	Part Number	Description
		Used to secure the tray rails to a rack, regardless of the rack type
	036-034-003	Square hole alignment pin (Quantity: 9) Replacement alignment pin used to mount tray rails in racks that have 0.375 in. square holes
	036-034-004	Threaded hole alignment pin (Quantity: 9) Replacement alignment pin used to mount tray rails in racks that have threaded holes

Mount the Cable Management Tray

If you plan to use the 1U cable management tray, mount the tray before mounting the SCv360 expansion enclosure.

Prerequisite

Required materials:

- Screwdriver (034-000-193)
- Four 8-32 x 0.75 in. knurled head Phillips screws (036-034-012)
- Left 1U cable management tray rail (042-034-012)
- Right 1U cable management tray rail (042-034-008)
- 1U cable management tray (042-033-060)

Steps

- 1 Adjust the length of the 1U cable management tray rails (042-034-012 and 042-034-008) to fit the rack.
- 2 Align the rails so that the UP arrow is pointed in the correct direction and the side of the rail labeled FRONT is at the front of the rack.
- 3 Insert the alignment pins of left and right rails into the mounting holes at the front and back of the rack.
- 4 Secure the rails by installing 8-32 x 0.75 in. screws (036-034-012) into the holes at the front and back of the rails.

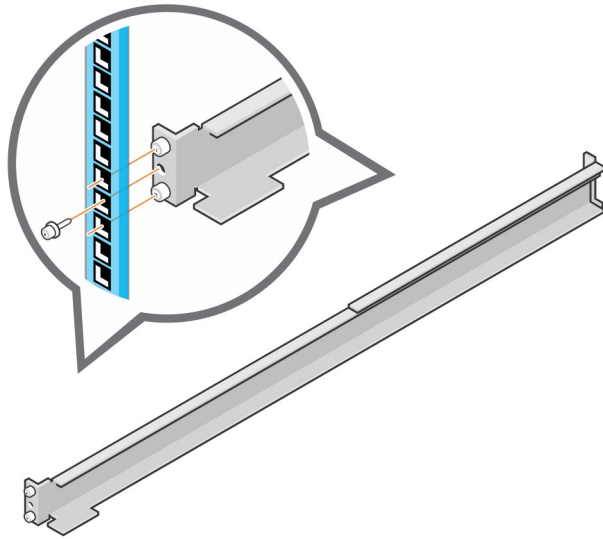

Figure 3. Secure Rails to Rack

- 5 Align the 1U cable management tray (042-033-060) so that the UP arrow is pointed in the correct direction and the side of the tray labeled FRONT is to the front of the rack.

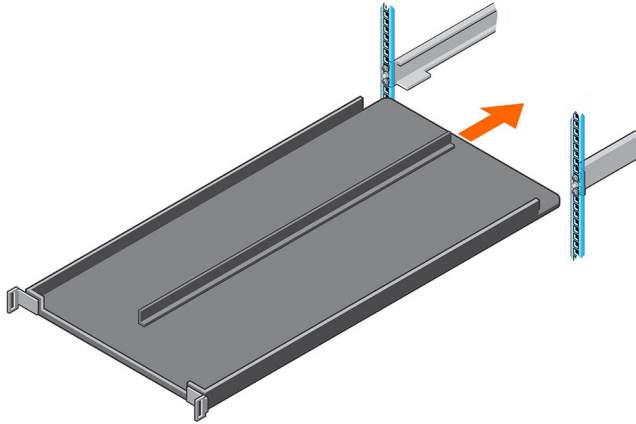

Figure 4. Align the Cable Management Tray

- 6 Slide the 1U cable management tray into the rails until it locks into place.

Mount the Expansion Enclosure

Install the rails in the rack, and mount the SCv360 expansion enclosure on the rails.

Prerequisite

Required materials:

- Screwdriver (034-000-193)
- Six clip nuts (106-569-307)
- Two M5 x 10 mm Phillips pan-head screws (106-002-452)
- Two M5 x 16 mm Phillips pan-head screws (106-002-453)

Steps

- 1 Adjust the length of the expansion enclosure rack rails to fit the rack.
- 2 Attach the right rail to the back post of the rack.
 - a Align the right rail with the lower two U spaces of the 4U mounting location.
 - b With the release latch on the outer part of the rack post, place the catch mechanism over the post.
 - c Push the rail back to secure the rail to the rack post.
An audible click indicates that the rail is secure in the post.

- d Make sure the post/catch mechanism is secure and attached to the rack post.

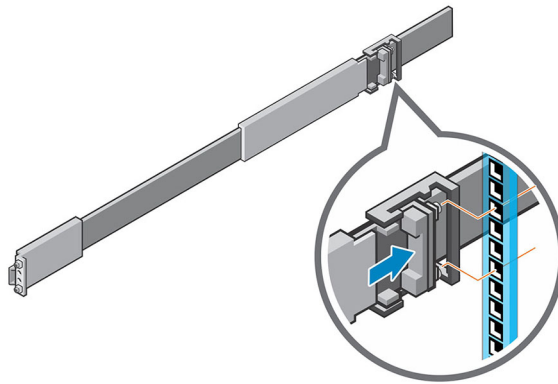

Figure 5. Attach Rail to the Back of the Rack

- 3 Attach the right rail to the front post of the rack.
- Align the right rail with the lower two U spaces of the 4U mounting location.
 - Pull the rail forward, with the alignment pins in the middle holes of the bottom two U spaces of the 4U mounting location.
- An audible click indicates that the rail is secure in the post.

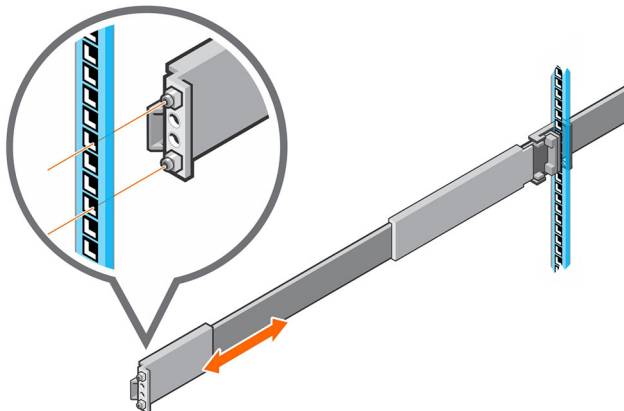

Figure 6. Attach Rail to the Front of the Rack

- 4 Secure the rail by installing an M5 x 10 mm screw (106-002-452) in the larger of the two holes at the front of the rail.

- 5 Secure the rail by installing an M5 x 16 mm screw (106-002-453) in the larger of the two holes at the back of the rail.
- 6 Repeat steps 2 through 5 to install the left rail.
- 7 Mount the expansion enclosure chassis on the rails.
 - a If a mechanical lift is available, use the four handles that shipped with the expansion enclosure to lift the expansion enclosure chassis onto a mechanical lift.
 - b If a mechanical lift is not available, remove the drives, cooling fans, power supply units (PSUs), and enclosure management modules (EMMs) from the expansion enclosure chassis and use the four handles to lift the chassis to the mounting location.
 - c From the front of the rack, extend the rack rails approximately 5 to 8 cm (2 to 3 in.) and align the expansion enclosure chassis rails with the rack rails.

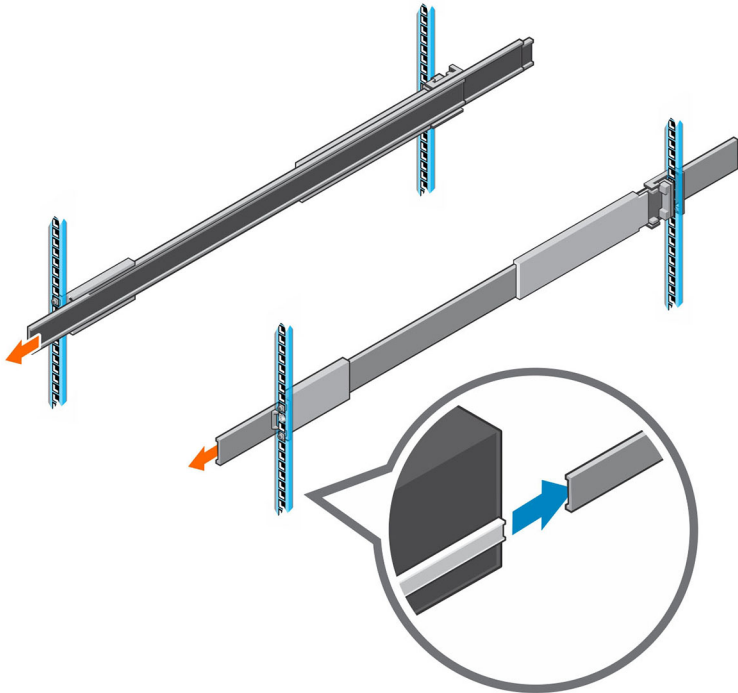

Figure 7. Extend the Rack Rails

- d Slide the rack rails over the expansion enclosure chassis rails.

- e Remove the four handles from the sides of the expansion enclosure chassis.
- f Slide the expansion enclosure chassis into the rack.

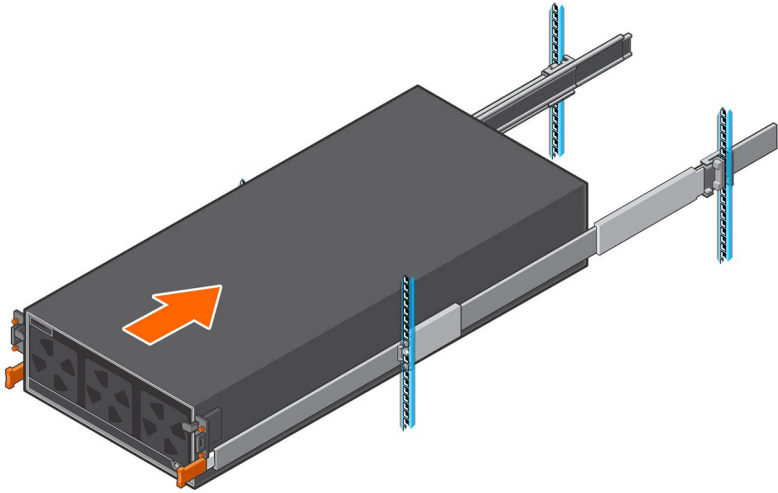

Figure 8. Mount the Expansion Enclosure into the Rack

- 8 If the drives, fans, PSUs, and EMMs were removed from the expansion enclosure chassis, reinstall these components in the chassis.
- 9 Secure the expansion enclosure chassis and top cover.
 - a Install the six clip nuts (106-569-307) into the rack holes that align with the shoulder screws on the front of the expansion enclosure chassis.
 - b Use the orange enclosure latch handles to push the expansion enclosure chassis completely into the rack.

Make sure that the self-locking latches are pushed in and fully engaged to prevent the expansion enclosure chassis from sliding out of the rack.
 - c Secure the expansion enclosure chassis to the rack using the orange shoulder screws.
 - d If the top cover is secured by two small shipping screws, remove the screws.
 - e Secure the top cover of the expansion enclosure chassis to the rack using the shoulder screws.

Install the Front Bezel

If a front bezel is shipped with the SCv360 expansion enclosure, install the bezel on the front of the expansion enclosure.

- 1 Align the bezel with the front of the expansion enclosure.
- 2 Press the two latches on front of bezel.

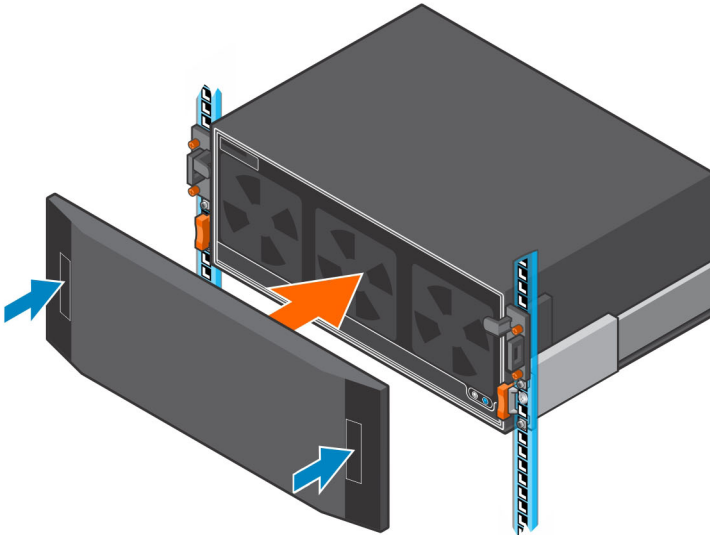

Figure 9. Install the Bezel

- 3 Push the bezel into place until it attaches to the expansion enclosure.
- 4 Release the latches on the front on the bezel.
- 5 If the bezel has key lock, lock the bezel with the key.

NOM Information (Mexico Only)

The following information is provided on the device described in this document in compliance with the requirements of the official Mexican standards (NOM):

Importer	Dell México, S.A. de C.V. Javier Barros Sierra, No. 540, Piso 10, Col. Lomas de Santa Fe C.P. 01219, Ciudad de México
Model number	CYAE
Supply voltage	200–240 VAC
Input frequency	50/60 Hz
Input current	4.5 A x2 (N+1)

Technical Specifications

The technical specifications of the SCv360 expansion enclosure are displayed in the following tables.

Drives

SAS hard drives	Dell Enterprise Plus Value drives Up to 60 hot-swappable 7.2K RPM 12 Gbps 3.5" SAS hard drives
-----------------	---

Connectivity

Configurations	SCv3000 and SCv3020 storage systems support up to three SCv360 expansion enclosures
----------------	---

Enclosure Management Modules (EMMs)

EMMs	Two hot-swappable EMMs with four 12 Gb SAS ports per EMM. The expansion enclosure supports Mini-SAS HD cables in lengths of 3 m, 4 m, and 5 m.
SAS connectors	SAS connectors are SFF-8644 compliant

Power Supplies

Wattage 1600 W per power supply

AC Power

Input voltage 200–240 VAC

Input frequency 50/60 Hz

Input current 4.5 A x2 (N+1)

Physical

Height (4U chassis) 17.5 cm (6.89 in.)

Height (4U chassis plus 1U cable management tray) 22.23 cm (8.75 in.)

Width (including rails) 44.45 cm (17.50 in.)

Depth (chassis only) 87.63 cm (34.5 in.)

Maximum depth (fully configured) 92.46 cm (36.4 in.)

Weight (maximum configuration) 102.05 kg (225.0 lb)

Environmental

Temperature

Operating 5° to 40°C (41° to 104°F) with a maximum temperature gradation of 10°C per hour

Storage -40° to 65°C (-40° to 149°F) with a maximum temperature gradation of 25°C per hour

Relative humidity

Operating 20% to 80% (noncondensing)

Storage 10% to 90% (noncondensing)

Altitude

Operating -16 to 2300 m (-50 to 7500 ft)

Environmental

Storage

-16 to 10,600 m (-50 to 35,000 ft)