



**Dell Storage Center
SCv2080 Storage System
Deployment Guide**



Notes, Cautions, and Warnings

-  **NOTE:** A NOTE indicates important information that helps you make better use of your computer.
-  **CAUTION:** A CAUTION indicates either potential damage to hardware or loss of data and tells you how to avoid the problem.
-  **WARNING:** A WARNING indicates a potential for property damage, personal injury, or death.

Contents

About this Guide.....	6
Revision History.....	6
Audience.....	6
Contacting Dell.....	6
Related Publications.....	6
1 About the SCv2080 Storage System.....	8
Storage Center Hardware Components.....	8
SCv2080 Storage System.....	8
Switches.....	8
Expansion Enclosures.....	8
Storage Center Architecture Options.....	8
Storage Center Replication.....	9
Storage Center Communication.....	9
Front-End Connectivity.....	9
Back-End Connectivity.....	13
System Administration.....	13
SCv2080 Storage System Hardware.....	13
SCv2080 Storage System Front-Panel Features and Indicators.....	13
SCv2080 Storage System Back-Panel Features and Indicators.....	15
SCv2080 Storage System Storage Controller Features and Indicators	16
SCv2080 Storage System Cooling Fan Module Features and Indicators.....	21
SCv2080 Storage System PSU Features and Indicators.....	21
SCv2080 Storage System Drives.....	22
SCv2080 Storage System Drive Numbering.....	23
SC180 Expansion Enclosure Overview.....	23
SC180 Expansion Enclosure Front-Panel Features and Indicators.....	23
SC180 Expansion Enclosure Back-Panel Features and Indicators.....	25
SC180 Expansion Enclosure Drives.....	27
SC180 Expansion Enclosure Drive Numbering.....	28
2 Install the Storage Center Hardware.....	29
Unpack and Inventory the Storage Center Equipment.....	29
Prepare the Installation Environment.....	29
Safety Precautions.....	29
Installation Safety Precautions.....	30
Electrical Safety Precautions.....	30
Electrostatic Discharge Precautions.....	30
General Safety Precautions.....	31
Installing the Storage System in a Rack.....	31
Installing the Hard Drives.....	36
3 Connect the Front-End Cabling.....	40



Types of Redundancy for Front-End Connections.....	40
Port Redundancy.....	40
Storage Controller Redundancy.....	40
Fault Domains.....	41
Multipath I/O.....	41
Cabling SAN-Attached Host Servers.....	41
Connecting to Fibre Channel Host Servers.....	42
Connecting to iSCSI Host Servers.....	50
Cabling Direct-Attached Host Servers.....	56
Preparing Host Servers.....	57
SAS Virtual Port Mode.....	57
Two Servers Connected to Dual 12 Gb 4-Port SAS Storage Controllers.....	57
Four Servers Connected to Dual 12 Gb 4-Port SAS Storage Controllers.....	58
Labeling the Front-End Cables.....	59
Cabling the Ethernet Management Port.....	60
Labeling the Ethernet Management Cables.....	61
Cabling the Embedded Ports for iSCSI Replication.....	62
Cabling the Replication Port for iSCSI Replication.....	62
Cabling the Management Port and Replication Port for iSCSI Replication.....	63
Cabling the Embedded Ports for iSCSI Host Connectivity.....	64
Two iSCSI Networks using the Embedded Ethernet Ports on a Storage System with Dual Fibre Channel Storage Controllers.....	64
Two iSCSI Networks Using the Embedded Ethernet Ports on a Storage System with Dual iSCSI Storage Controllers.....	65
4 Connect the Back-End Cabling and Connect the Power.....	68
SC180 Expansion Enclosure Cabling Guidelines.....	68
Back-End SAS Redundancy.....	68
Back-End SAS Port Types.....	68
Back-End Connections for an SCv2080 Storage System Without an Expansion Enclosure.....	69
Back-End Connections for an SCv2080 with an Expansion Enclosure.....	69
Label the Back-End Cables.....	70
Connect Power Cables and Turn on the Storage System.....	71
5 Discover and Configure the Storage Center.....	74
Locating Your Service Tag.....	74
Worksheet to Record System Information.....	74
Storage Center Information.....	74
iSCSI Fault Domain Information.....	75
Additional Storage Center Information.....	75
Fibre Channel Zoning Information.....	76
Supported Operating Systems for Storage Center Automated Setup	76
Install and Use the Dell Storage Manager Client.....	77
Discover and Select an Uninitialized Storage Center.....	77
Deploy the Storage Center Using the Direct Connect Method.....	78
Set System Information.....	78



Set Administrator Information.....	78
Configure iSCSI Fault Domains.....	79
Confirm the Storage Center Configuration.....	79
Initialize the Storage Center.....	79
Review Fibre Channel Front-End Configuration.....	80
Review SAS Front-End Configuration.....	80
Configure Time Settings.....	80
Configure SMTP Server Settings.....	80
Configure Key Management Server Settings.....	81
Review the SupportAssist System State Information Collection and Storage Agreement.....	81
Advantages and Benefits of Dell SupportAssist.....	81
Provide Contact Information.....	81
Update Storage Center.....	82
Set Default Storage Profile.....	82
Complete Configuration and Perform Next Steps.....	82
Set Up a localhost or VMware Host.....	83
Set Up a localhost from Initial Setup.....	83
Set Up a VMware vSphere Host from Initial Setup.....	83
Set Up a VMware vCenter Host from Initial Setup.....	84
Create a Volume Using the Multiple-Step Wizard.....	84
Set the Default Storage Profile for New Volumes.....	85
Configure Embedded iSCSI Ports.....	85

6 Perform Post-Setup Tasks..... 86

Verify Connectivity and Failover.....	86
Put the Storage Center Into Maintenance Mode.....	86
Create Test Volumes.....	86
Test Basic Connectivity.....	87
Test Storage Controller Failover.....	87
Test MPIO.....	87
Clean Up Test Volumes.....	88
Send Diagnostic Data Using Dell SupportAssist.....	88

A Adding or Removing an Expansion Enclosure..... 89

Adding an Expansion Enclosure to a Storage System.....	89
Check the Disk Count before Adding an Expansion Enclosure.....	89
Add the Expansion Enclosure to the A-Side Chain.....	90
Add the Expansion Enclosure to the B-Side Chain.....	91
Label the Back-End Cables.....	92
Removing an Expansion Enclosure from a Chain Currently in Service.....	93
Release the Disks in the Expansion Enclosure.....	94
Disconnect the A-Side Chain from the SC180 Expansion Enclosure.....	94
Disconnect the B-Side Chain from the SC180 Expansion Enclosure.....	96

B Troubleshooting Storage Center Deployment..... 98

Troubleshooting Storage Controllers.....	98
Troubleshooting Hard Drives.....	98
Troubleshooting Expansion Enclosures.....	98



About this Guide

This guide describes the features and technical specifications of the SCv2080 storage system.

Revision History

Document Number: M9R8N

Revision	Date	Description
A00	April 2015	Initial release
A01	August 2015	Updated rail installation instructions
A02	June 2016	Updated with continuation changes
A03	December 2016	Verified and updated the deployment instructions, added a new topic for direct connect discovery, and added continuation changes

Audience

The information provided in this guide is intended for storage or network administrators and deployment personnel.

Contacting Dell

Dell provides several online and telephone-based support and service options. Availability varies by country and product, and some services might not be available in your area.

To contact Dell for sales, technical support, or customer service issues, go to www.dell.com/support.

- For customized support, type your system service tag on the support page and click **Submit**.
- For general support, browse the product list on the support page and select your product.

Related Publications

The following documentation is available for the SCv2080 storage system.

- *Dell Storage Center SCv2080 Storage System Getting Started Guide*
Provides information about an SCv2080 storage system, such as installation instructions and technical specifications.
- *Dell Storage Center SCv2080 Storage System Owner's Manual*
Provides information about an SCv2080 storage system, such as hardware features, replacing customer replaceable components, and technical specifications.
- *Dell Storage Center Release Notes*
Provides information about new features and known and resolved issues for the Storage Center software.
- *Dell Storage Center Update Utility Administrator's Guide*
Describes how to use the Storage Center Update Utility to install Storage Center software updates. Updating Storage Center software using the Storage Center Update Utility is intended for use only by sites that cannot update Storage Center using standard methods.
- *Dell Storage Center Software Update Guide*
Describes how to update Storage Center software from an earlier version to the current version.
- *Dell Storage Center Command Utility Reference Guide*



Provides instructions for using the Storage Center Command Utility. The Command Utility provides a command-line interface (CLI) to enable management of Storage Center functionality on Windows, Linux, Solaris, and AIX platforms.

- *Dell Storage Center Command Set for Windows PowerShell*
Provides instructions for getting started with Windows PowerShell cmdlets and scripting objects that interact with the Storage Center using the PowerShell interactive shell, scripts, and PowerShell hosting applications. Help for individual cmdlets is available online.
- *Dell Storage Manager Client Administrator's Guide*
Provides information about the Dell Storage Manager Client and how it can be used to manage a Storage Center.
- *Dell Storage Manager Administrator's Guide*
Provides instructions for using the Data Collector Manager and the Dell Storage Manager Client.
- *Dell TechCenter*
Provides technical white papers, best practice guides, and frequently asked questions about Dell Storage products. Go to <http://en.community.dell.com/techcenter/storage/>.



About the SCv2080 Storage System

The SCv2080 storage system provides the central processing capabilities for the Storage Center Operating System (OS) and management of RAID storage.

The SCv2080 storage system holds the physical drives that provide storage for the Storage Center. If additional storage is needed, the SCv2080 also supports a single SC180 expansion enclosure.

Storage Center Hardware Components

The Storage Center described in this document consists of an SCv2080 storage system, enterprise-class switches, and an SC180 expansion enclosure.

The SCv2080 storage system supports a single SC180 expansion enclosure to allow for storage expansion.

 **NOTE: The cabling between the storage system, switches, and host servers is referred to as front-end connectivity. The cabling between the storage system and an expansion enclosure is referred to as back-end connectivity.**

SCv2080 Storage System

The SCv2080 is a 5U storage system that supports up to 84 internal 3.5-inch hot-swappable SAS hard drives installed in a two-drawer, three-row, 14-column configuration.

The SCv2080 storage system contains two redundant power supply units, five redundant cooling fans, and two storage controllers with multiple I/O ports that provide communication with servers and expansion enclosures. The SCv2080 storage system requires a minimum of 14 drives to deploy.

Switches

Dell offers enterprise-class switches as part of the total Storage Center solution.

The SCv2080 storage system supports Fibre Channel (FC) and Ethernet switches, which provide robust connectivity to servers and allow for the use of redundant transport paths. Fibre Channel (FC) or Ethernet switches can provide connectivity to a remote Storage Center to allow for replication of data. In addition, Ethernet switches provide connectivity to a management network to allow configuration, administration, and management of the Storage Center.

Expansion Enclosures

An SCv2080 storage system supports a single SC180 expansion enclosure. The expansion enclosure allows the data storage capabilities of the SCv2080 to be expanded beyond the 84 internal drives in the storage system chassis.

The SCv2080 storage system supports a total of 168 drives per Storage Center system. This total includes the drives in the SCv2080 storage system chassis and the drives in the SC180 expansion enclosure chassis.

Storage Center Architecture Options

A Storage Center with an SCv2080 storage system can be deployed in two configurations:

- An SCv2080 storage system without an SC180 expansion enclosure

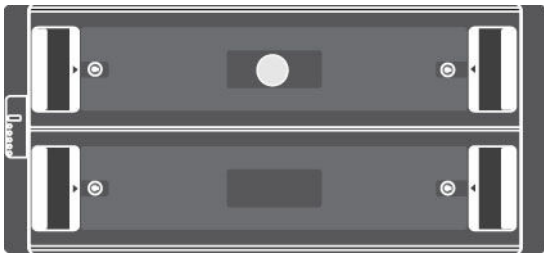

Figure 1. SCv2080 without an Expansion Enclosure

- An SCv2080 storage system with one SC180 expansion enclosure

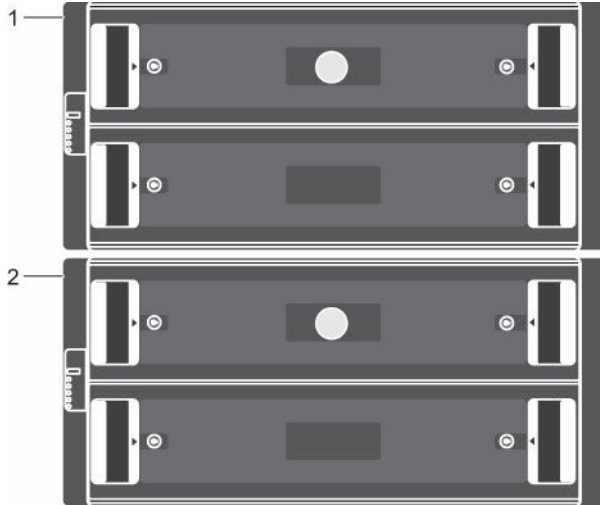

Figure 2. SCv2080 with One Expansion Enclosure

1. SC180 expansion enclosure

2. SCv2080 storage system

Storage Center Replication

Storage Center sites can be collocated or remotely connected and data can be replicated between sites. Storage Center replication can duplicate volume data to another site in support of a disaster recovery plan or to provide local access to a remote data volume. Typically, data is replicated remotely as part of an overall disaster avoidance or recovery plan.

The SCv2000 Series Storage Center supports replication to other SCv2000 Series Storage Centers. However, a Dell Storage Manager Data Collector must be used to replicate data between the storage systems.

For more information about installing, managing the Data Collector, and setting up replications, see the *Dell Storage Manager Administrator's Guide*.

Storage Center Communication

A Storage Center uses multiple types of communication for both data transfer and administrative functions. Storage Center communication is classified into three types: front end, back end, and system administration.

Front-End Connectivity

Front-end connectivity provides I/O paths from servers to a storage system and replication paths from one Storage Center to another Storage Center. The SCv2080 storage system provides the following types of front-end connectivity:

- **Fibre Channel:** Hosts, servers, or Network Attached Storage (NAS) appliances access storage by connecting to the storage system Fibre Channel ports through one or more Fibre Channel switches. Connecting host servers directly to the storage system, without using Fibre Channel switches, is not supported.

When replication is licensed, the SCv2080 can use the front-end Fibre Channel ports to replicate data to another Storage Center.



- **iSCSI:** Hosts, servers, or Network Attached Storage (NAS) appliances access storage by connecting to the storage system iSCSI ports through one or more Ethernet switches. Connecting host servers directly to the storage system, without using Ethernet switches, is not supported.
When replication is licensed, the SCv2080 can use the front-end iSCSI ports to replicate data to another Storage Center.
- **SAS:** Hosts or servers access storage by connecting directly to the storage system SAS ports.

NOTE: When replication is licensed, the SCv2080 can use the embedded REPL port to perform iSCSI replication to another SCv2000 series Storage Center.

If replication is licensed and the Flex Port license is installed, the SCv2080 can use the embedded MGMT port to perform iSCSI replication to another SCv2000 series Storage Center. In addition, the SCv2080 can use the embedded MGMT and REPL ports as front-end iSCSI ports for connectivity to host servers when the Flex Port license is installed.

SCv2080 Storage System with Fibre Channel Front-End Connectivity

An SCv2080 storage system with Fibre Channel front-end connectivity may communicate with the following components of a Storage Center system.

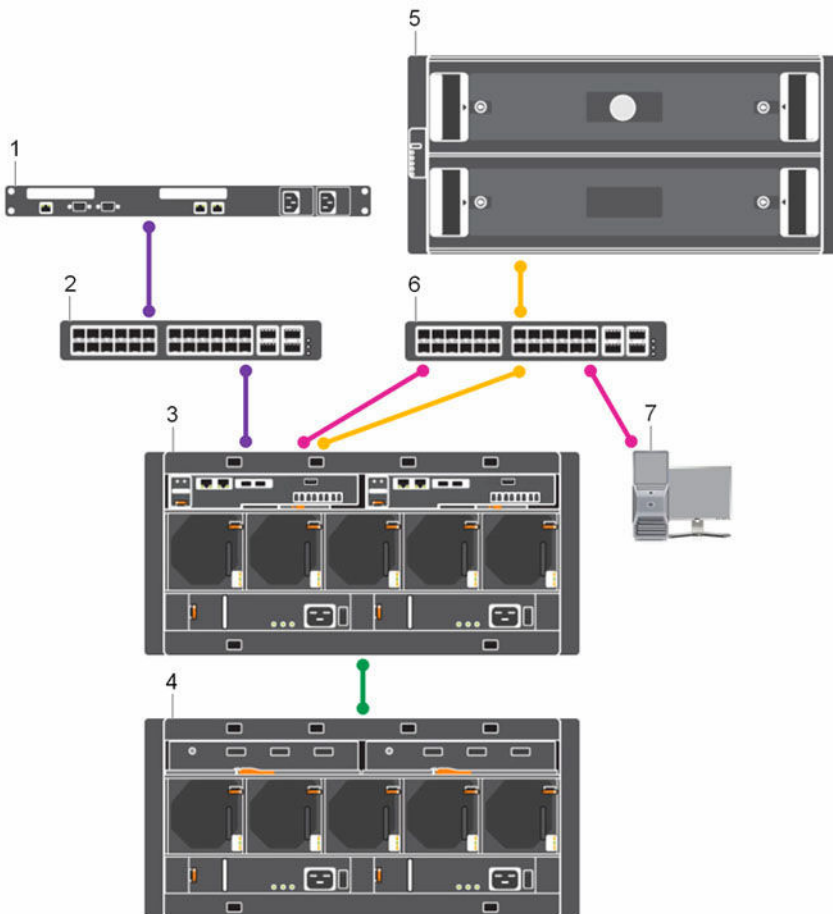

Figure 3. Storage System with Fibre Channel Front-End Connectivity

Item	Description	Speed	Communication Type
1	Server with Fibre Channel host bus adapters (HBAs)	8 Gbps or 16 Gbps	Front End
2	Fibre Channel switch	8 Gbps or 16 Gbps	Front End
3	SCv2080 Storage System with FC front-end connectivity	8 Gbps or 16 Gbps	Front End
4	SC180 Expansion Enclosures	6 Gbps per channel	Back End



Item	Description	Speed	Communication Type
5	Remote Storage Center connected via iSCSI for replication	1 Gbps or 10 Gbps	Front End
6	Ethernet switch	1 Gbps or 10 Gbps (Management/Replication)	Front End
7	Management network (computer connected to the storage system through the Ethernet switch)	Up to 1 Gbps	System Administration

SCv2080 Storage System with iSCSI Front-End Connectivity

An SCv2080 storage system with iSCSI front-end connectivity may communicate with the following components of a Storage Center system.

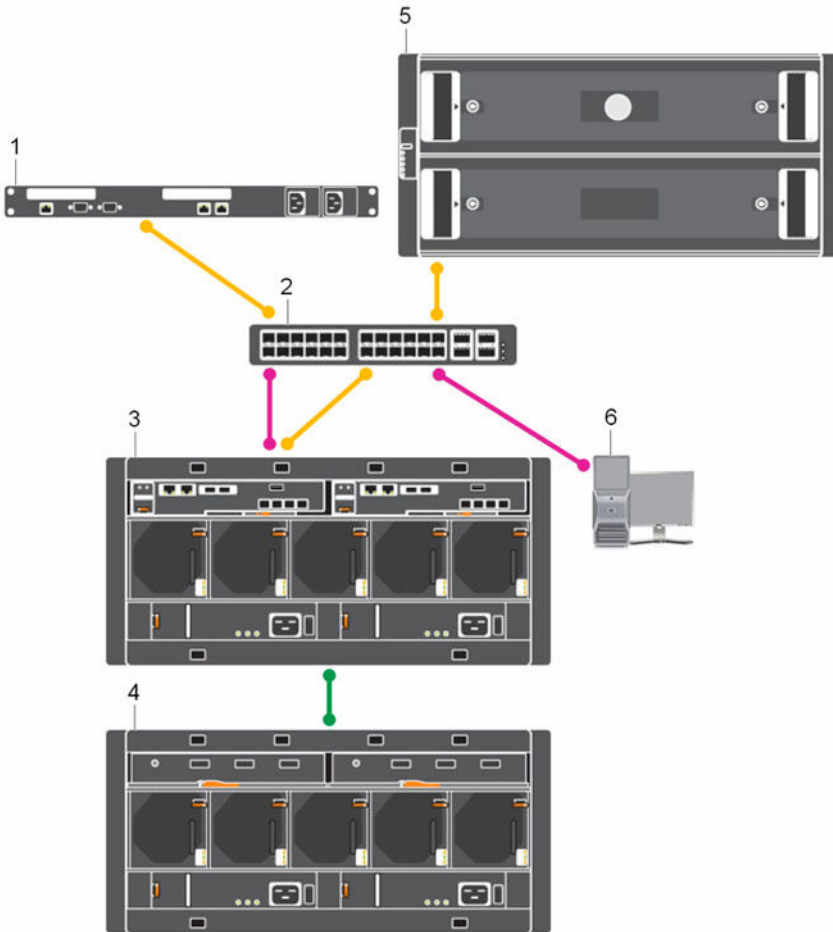

Figure 4. Storage System with iSCSI Front-End Connectivity

Item	Description	Speed	Communication Type
1	Server with Ethernet (iSCSI) ports or iSCSI host bus adapters (HBAs)	1 Gb or 10 Gb	Front End
2	Ethernet switch — A pair of Ethernet switches is recommended for optimal redundancy and connectivity.	1 Gb or 10 Gb	Front End
3	SCv2080 with iSCSI front-end connectivity	1 Gb or 10 Gb	Front End
4	SC180 Expansion Enclosures	12 Gbps per channel	Back End
5	Remote Storage Center connected via iSCSI for replication	1 Gbps or 10 Gbps	Front End



Item	Description	Speed	Communication Type
6	Management network (computer connected to the storage system through the Ethernet switch)	Up to 1 Gbps	System Administration

SCv2080 Storage System with Front-End SAS Connectivity

An SCv2080 storage system with front-end SAS connectivity may communicate with the following components of a Storage Center system.

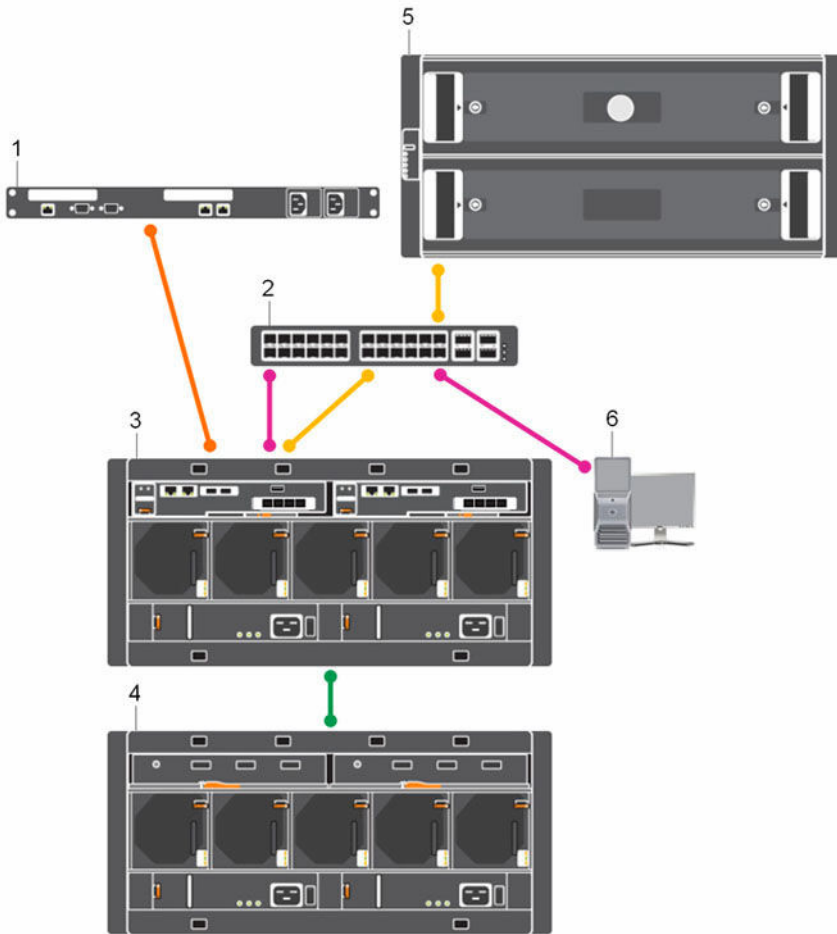

Figure 5. Storage System with Front-End SAS Connectivity

Item	Description	Speed	Communication Type
1	Server with SAS host bus adapters (HBAs)	12 Gbps per channel	Front End
2	Ethernet switch	1 Gbps or 10 Gbps (Management/Replication)	Front End
3	SCv2080 with front-end SAS connectivity	12 Gbps per channel	Front End
4	SC180 Expansion Enclosures	6 Gbps per channel	Back End
5	Remote Storage Center connected via iSCSI for replication	1 Gbps or 10 Gbps	Front End
6	Management network (computer connected to the storage system through the Ethernet switch)	Up to 1 Gbps	System Administration

Back-End Connectivity

Back-end connectivity is strictly between the storage system and the expansion enclosure, which holds the physical drives that provide back-end expansion storage.

The SCv2080 supports SAS connectivity to a single SC180 expansion enclosure.

System Administration

To perform system administration, the Storage Center communicates with computers using the Ethernet management (MGMT) port on the storage controllers.

The Ethernet management port is used for Storage Center configuration, administration, and management.

SCv2080 Storage System Hardware

The SCv2080 ships with Dell Enterprise drives, two redundant power supply units, five redundant cooling fans, and two redundant storage controllers.

Each storage controller contains the front-end, back-end, and management communication ports of the storage system.

SCv2080 Storage System Front-Panel Features and Indicators

The front panel of the SCv2080 contains power and status indicators, drawer-specific indicators, and a unit ID display. In addition, the hard drives are installed and removed from the drawers on the front of the storage system chassis.

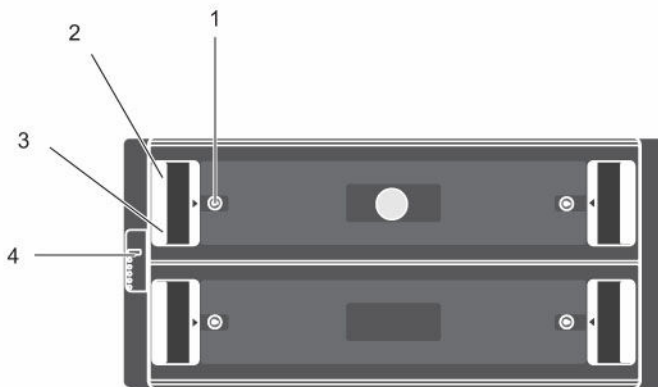















Figure 6. SCv2080 Storage System Front-Panel Features and Indicators

Item	Name	Panel	Description
1	Drawer-specific anti-tamper locks		Locks the drawer shut using a Torx T20 screwdriver until the red arrows point to the locked icon (away from the center of the chassis).
2	Drawer-specific left and right side status indicators	 	<ul style="list-style-type: none"> • Sideplane OK/Power Good <ul style="list-style-type: none"> – Off — Sideplane card or cable fault – Green — Sideplane card and cable are functional (though a fault may be indicated by one or more of the following LEDs) • Drawer Fault

Item	Name	Panel	Description
			<ul style="list-style-type: none"> Amber — Sideplane card fault or drive failure causing loss of availability or redundancy
			<ul style="list-style-type: none"> Logical Fault <ul style="list-style-type: none"> Amber (steady) — Host indicated drive fault Amber (flashing) — Arrays in impacted state Cable Fault <ul style="list-style-type: none"> Amber — Cable fault
3	Drawer-specific left and right side storage system activity indicators		<p>Activity Bar Graph — Six variable-intensity LEDs dynamically displaying access of the drives in that specific drawer</p>
4	Status indicator for storage system	      	<ul style="list-style-type: none"> Unit ID Display — Numerical display primarily used to display the unit identification number Input Switch — Not used Power On/Standby <ul style="list-style-type: none"> Off — Storage system does not have power Green — Storage system is on (operational) Amber — Storage system is in standby mode (not operational) Module Fault <ul style="list-style-type: none"> Amber — Hardware fault (an LED may be lit on a PSU, drawer, DDIC, fan module, or IO module indicating the part at fault) Logical Status <ul style="list-style-type: none"> Amber — Change of status or fault from something other than the storage system itself (this status is typically associated with a disk drive as indicated by its own fault LED) Drawer 1 Fault <ul style="list-style-type: none"> Amber — Drive, cable, or sideplane fault has occurred in drawer 1 Drawer 2 Fault <ul style="list-style-type: none"> Amber — Drive, cable, or sideplane fault has occurred in drawer 2 <p> NOTE: Both drawer fault LEDs (and all contained DDIC LEDs) flash when the storage system indicator is set to On in Dell Storage Manager Client.</p>

SCv2080 Storage System Back-Panel Features and Indicators

The SCv2080 back panel contains the storage system power, connectivity, and fault indicators.

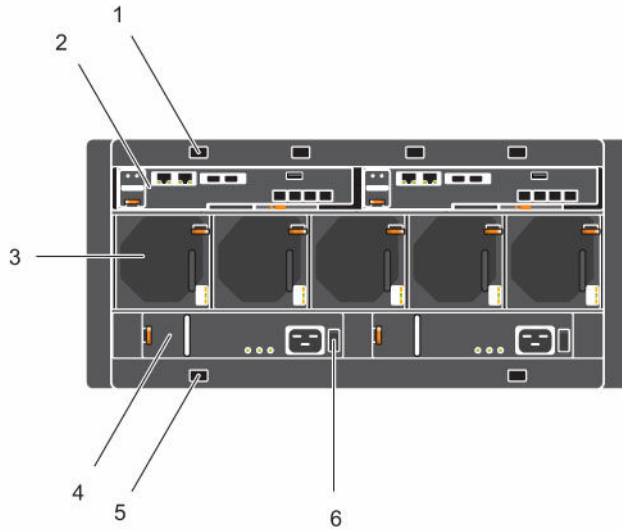



Figure 7. SCv2080 Storage System Back-Panel Features and Indicators

Item	Name	Icon	Description
1	Optional cable retention positions (4)	—	Locations for optional cable retention brackets.
2	Storage controller (2)	—	<p>Each storage controller contains:</p> <ul style="list-style-type: none"> • Battery backup unit (BBU): Allows the storage controller to shut down gracefully when a loss of AC power is detected • Back-end ports: Two 6 Gbps SAS ports • Front-end ports: Fibre Channel ports, iSCSI ports, or SAS ports • MGMT port: Embedded Ethernet/iSCSI port, which is used for system management <p> NOTE: The MGMT port can share iSCSI traffic if the Flex Port license is installed.</p> <ul style="list-style-type: none"> • REPL port: Embedded iSCSI port, which is typically used for replication to another Storage Center <p> NOTE: A Flex Port license is required to connect host servers through the embedded iSCSI ports.</p>
3	Cooling fans (5)	—	Fans that provide cooling for the storage system.
4	Power supply units (2)	—	2.8 kW power supply that provides power for the storage system.
5	Optional cable retention positions (4)	—	Locations for optional cable retention brackets
6	Power switch (2)	—	Controls power for the storage system. Each power supply has one switch.

SCv2080 Storage System Storage Controller Features and Indicators

The SCv2080 storage system includes two storage controllers in two interface slots.

SCv2080 Storage System Storage Controller with Fibre Channel Front-End Ports

The following figures show the features and indicators on a storage controller with Fibre Channel front-end ports.

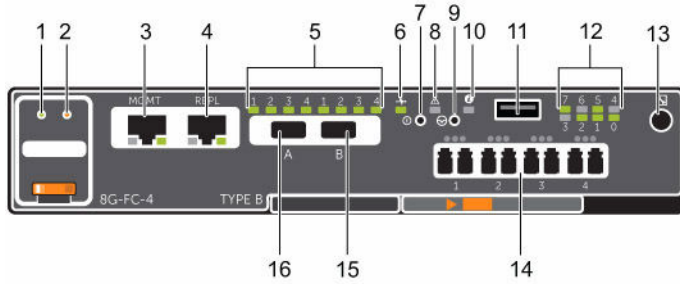

Figure 8. SCv2080 Storage System Storage Controller with Four 8 Gb Fibre Channel Front-End Ports

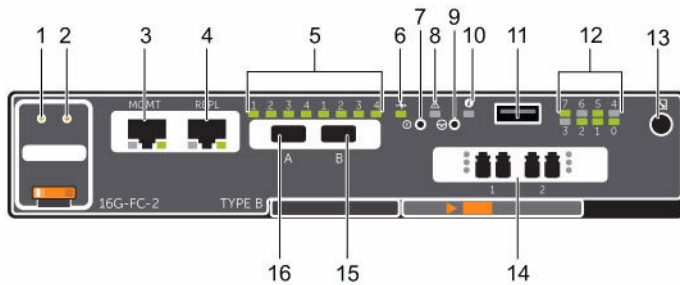











Figure 9. SCv2080 Storage System Storage Controller with Two 16 Gb Fibre Channel Front-End Ports

Item	Control/Feature	Icon	Description
1	Battery status indicator		<ul style="list-style-type: none"> Blinking green (on 0.5 sec. / off 1.5 sec.): Battery heartbeat Fast blinking green (on 0.5 sec. / off 0.5 sec.): Battery is charging Steady green: Battery is ready
2	Battery fault indicator		<ul style="list-style-type: none"> Off: No faults Blinking amber: Correctable fault detected Steady amber: Uncorrectable fault detected; replace battery
3	MGMT port (Slot 3/Port 1)	—	<p>Ethernet/iSCSI port that is typically used for storage system management and access to the BMC</p> <p> NOTE: To use the MGMT port as an iSCSI port for replication to another Storage Center, a Flex Port license and replication license are required. To use the MGMT port as a front-end connection to host servers, a Flex Port license is required.</p>
4	REPL port (Slot 3/Port 2)	—	<p>Ethernet/iSCSI port that is typically used for replication to another Storage Center (requires a replication license)</p> <p> NOTE: To use the RELP port as a front-end connection to host servers, a Flex Port license is required.</p>
5	SAS activity indicators	—	<p>There are four SAS PHYs per SAS port.</p> <ul style="list-style-type: none"> Off: SAS PHY is not connected Steady green: SAS PHY is connected, but not active Blinking green: SAS PHY is not connected nor active



Item	Control/Feature	Icon	Description
6	Storage controller status		On: Storage controller completed POST
7	Recessed power off button		Not currently used
8	Storage controller fault		<ul style="list-style-type: none"> Off: No faults Steady amber: Firmware has detected an error Blinking amber: Storage controller is performing POST
9	Recessed reset button		Not currently used
10	Identification LED		<ul style="list-style-type: none"> Off: Identification disabled Blinking blue (for 15 sec.): Identification is enabled Blinking blue (continuously): Storage controller shut down to the Advanced Configuration and Power Interface (ACPI) S5 state
11	USB port		One USB 3.0 connector
12	Diagnostic LEDs (8)	—	<ul style="list-style-type: none"> Green LEDs 0–3: Low byte hex POST code Green LEDs 4–7: High byte hex POST code
13	Serial port (3.5 mm mini jack)		Not for customer use
14	Two options: <ul style="list-style-type: none"> Four Fibre Channel ports (Slot 1/Port 1, Slot 1/Port 2, Slot 1/Port 3, and Slot 1/Port 4) with three LEDs per port Two Fibre Channel ports (Slot 1/Port 1 and Slot 1/Port 2) with three LEDs per port 	—	<p>LEDs for the four 8 Gb Fibre Channel ports:</p> <ul style="list-style-type: none"> All off: No power All on: Booting up Blinking amber: 2 Gbps activity Blinking green: 4 Gbps activity Blinking yellow: 8 Gbps activity Blinking amber and yellow: Beacon All blinking (simultaneous): Firmware initialized All blinking (alternating): Firmware fault <p>LEDs for the two 16 Gb Fibre Channel ports:</p> <ul style="list-style-type: none"> All off: No power All on: Booting up Blinking amber: 4 Gbps activity Blinking green: 8 Gbps activity Blinking yellow: 16 Gbps activity Blinking amber and yellow: Beacon All blinking (simultaneous): Firmware initialized All blinking (alternating): Firmware fault
15	Mini-SAS port B (Slot 2/Port 2)		Back-end expansion port B
16	Mini-SAS port A (Slot 2/Port 1)		Back-end expansion port A

SCv2080 Storage System Storage Controller with iSCSI Front-End Ports

The following figures show the features and indicators on a storage controller with iSCSI front-end ports.

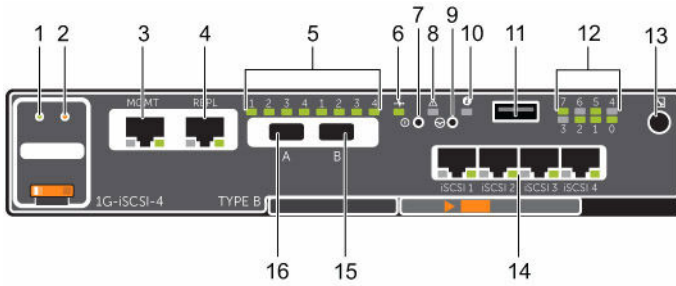

Figure 10. SCv2080 Storage System Storage Controller with Four 1 GbE iSCSI Front-End Ports

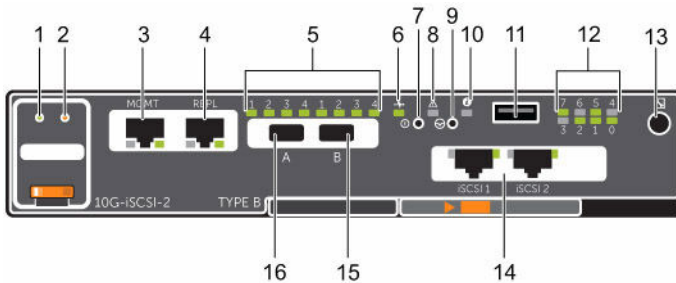

Figure 11. SCv2080 Storage System Storage Controller with Two 10 GbE iSCSI Front-End Ports

Item	Control/Feature	Icon	Description
1	Battery status indicator		<ul style="list-style-type: none"> Blinking green (on 0.5 sec. / off 1.5 sec.): Battery heartbeat Fast blinking green (on 0.5 sec. / off 0.5 sec.): Battery is charging Steady green: Battery is ready
2	Battery fault indicator		<ul style="list-style-type: none"> Off: No faults Blinking amber: Correctable fault detected Steady amber: Uncorrectable fault detected; replace battery
3	MGMT port (Slot 3/Port 1)	—	Ethernet/iSCSI port that is typically used for storage system management and access to the BMC NOTE: To use the MGMT port as an iSCSI port for replication to another Storage Center, a Flex Port license and replication license are required. To use the MGMT port as a front-end connection to host servers, a Flex Port license is required.
4	REPL port (Slot 3/Port 2)	—	Ethernet/iSCSI port that is typically used for replication to another Storage Center NOTE: To use the RELP port as a front-end connection to host servers, a Flex Port license is required.
5	SAS activity indicators	—	There are four SAS PHYs per SAS port. <ul style="list-style-type: none"> Off: SAS PHY is not connected Steady green: SAS PHY is connected, but not active Blinking green: SAS PHY is not connected nor active
6	Storage controller status		On: Storage controller completed POST
7	Recessed power off button		Not currently used

Item	Control/Feature	Icon	Description
8	Storage controller fault		<ul style="list-style-type: none"> Off: No faults Steady amber: Firmware has detected an error Blinking amber: Storage controller is performing POST
9	Recessed reset button		Not currently used
10	Identification LED		<ul style="list-style-type: none"> Off: Identification disabled Blinking blue (for 15 sec.): Identification is enabled Blinking blue (continuously): Storage controller shut down to the Advanced Configuration and Power Interface (ACPI) S5 state
11	USB port		One USB 3.0 connector
12	Diagnostic LEDs (8)	—	<ul style="list-style-type: none"> Green LEDs 0–3: Low byte hex POST code Green LEDs 4–7: High byte hex POST code
13	Serial port (3.5 mm mini jack)		Not for customer use
14	Two options: <ul style="list-style-type: none"> Four iSCSI ports (Slot 1/Port 1, Slot 1/Port 2, Slot 1/Port 3, and Slot 1/Port 4) with two LEDs per port Two iSCSI ports (Slot 1/Port 1 and Slot 1/Port 2) with two LEDs per port 	—	<ul style="list-style-type: none"> Off: No power Steady Amber: Link Blinking Green: Activity
15	Mini-SAS port B (Slot 2/Port 2)		Back-end expansion port B
16	Mini-SAS port A (Slot 2/Port 1)		Back-end expansion port A

SCv2080 Storage System Storage Controller with Front-End SAS Ports

The following figure shows the features and indicators on a storage controller with front-end SAS ports.

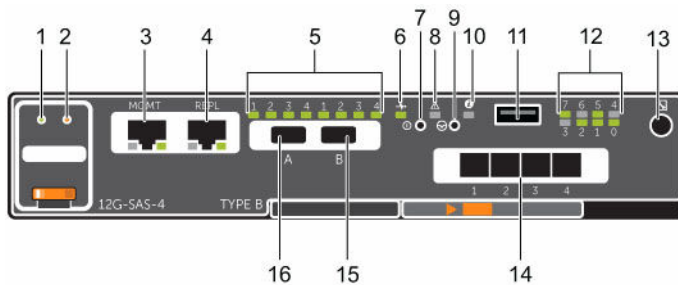













Figure 12. SCv2080 Storage System Storage Controller with Four 12 Gb Front-End SAS Ports

Item	Control/Feature	Icon	Description
1	Battery status indicator		<ul style="list-style-type: none"> Blinking green (on 0.5 sec. / off 1.5 sec.): Battery heartbeat Fast blinking green (on 0.5 sec. / off 0.5 sec.): Battery is charging Steady green: Battery is ready
2	Battery fault indicator		<ul style="list-style-type: none"> Off: No faults Blinking amber: Correctable fault detected Steady amber: Uncorrectable fault detected; replace battery

Item	Control/Feature	Icon	Description
3	MGMT port (Slot 3/Port 1)	—	<p>Ethernet/iSCSI port that is typically used for storage system management and access to the BMC</p> <p> NOTE: To use the MGMT port as an iSCSI port for replication to another Storage Center, a Flex Port license and replication license are required. To use the MGMT port as a front-end connection to host servers, a Flex Port license is required.</p>
4	REPL port (Slot 3/Port 2)	—	<p>Ethernet/iSCSI port that is typically used for replication to another Storage Center</p> <p> NOTE: To use the RELP port as a front-end connection to host servers, a Flex Port license is required.</p>
5	SAS activity indicators	—	<p>There are four SAS PHYs per SAS port.</p> <ul style="list-style-type: none"> • Off: SAS PHY is not connected • Steady green: SAS PHY is connected, but not active • Blinking green: SAS PHY is not connected nor active
6	Storage controller module status		On: Storage controller completed POST
7	Recessed power off button		Not currently used
8	Storage controller module fault		<ul style="list-style-type: none"> • Off: No faults • Steady amber: Firmware has detected an error • Blinking amber: Storage controller is performing POST
9	Recessed reset button		Not currently used
10	Identification LED		<ul style="list-style-type: none"> • Off: Identification disabled • Blinking blue (for 15 sec.): Identification is enabled • Blinking blue (continuously): Storage controller shut down to the Advanced Configuration and Power Interface (ACPI) S5 state
11	USB port		One USB 3.0 connector
12	Diagnostic LEDs (8)	—	<ul style="list-style-type: none"> • Green LEDs 0–3: Low byte hex POST code • Green LEDs 4–7: High byte hex POST code
13	Serial port (3.5 mm mini jack)		Not for customer use
14	Four Mini-SAS High Density (HD) ports (Slot 1/Port 1, Slot 1/Port 2, Slot 1/Port 3, and Slot 1/Port 4)	—	<p>Front-end connectivity ports</p> <p> NOTE: The mini-SAS HD ports are for front-end connectivity only and cannot be used for back-end expansion.</p>
15	Mini-SAS port B (Slot 2/Port 2)		Back-end expansion port B
16	Mini-SAS port A (Slot 2/Port 1)		Back-end expansion port A

SCv2080 Storage System Cooling Fan Module Features and Indicators

SCv2080 Storage Systems include five cooling fan modules in five interface slots.

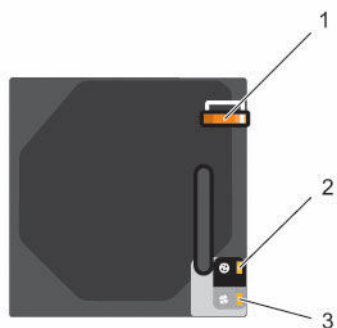

Figure 13. SCv2080 Storage System Cooling Fan Module Features and Indicators

Item	Control/Feature	Icon	Description
1	Release latch	—	Press the release latch to remove the cooling fan module.
2	Module OK		<ul style="list-style-type: none"> Green — Module is functioning properly
3	Fan fault		<ul style="list-style-type: none"> Amber — Loss of communication with the cooling fan module, or reported fan speed is out of tolerance

SCv2080 Storage System PSU Features and Indicators

SCv2080 Storage Systems include two power supply units (PSUs) in two interface slots.

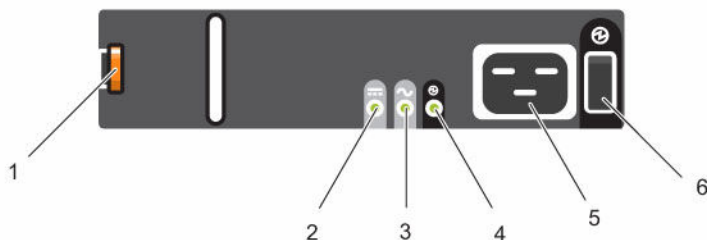



Figure 14. SCv2080 Storage System PSU Features and Indicators

Item	Control/Feature	Icon	Description
1	Release latch	—	Press the release latch to remove the PSU.
2	PSU fault		<ul style="list-style-type: none"> Amber (steady) — PSU fault, PSU not supplying power Amber (flashing) — PSU firmware is downloading
3	AC fault		<ul style="list-style-type: none"> Amber (steady) — AC power is not detected Amber (flashing) — PSU firmware is downloading



Item	Control/Feature	Icon	Description
4	Power OK		<ul style="list-style-type: none"> Green (steady) — This PSU is providing power Green (flashing) — AC power is present, but this PSU is in standby mode (the other PSU is providing power)
5	Power outlet	—	Power outlet for the storage system
6	Power switch	—	Controls power for the storage system

Separate and unique conditions are indicated if all three LEDs are in the same state:

- If all three LEDs are off, then neither PSU has AC power.
- If all three LEDs are on, then the General Enclosure Management (GEM) software has lost communication with the PSU.

SCv2080 Storage System Drives

The SCv2080 storage system supports only Dell Enterprise hard disk drives (HDDs) and Dell Enterprise solid-state drives (eSSDs). Each drive is installed in a Disk Drive In Carrier (DDIC) and each DDIC includes one status indicator.

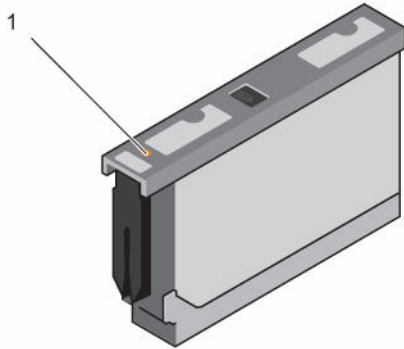

Figure 15. DDIC and Status Indicator

Item	Feature	Indicator Code
1	DDIC fault indicator	<ul style="list-style-type: none"> Amber — Drive fault Amber (flashing) — Flashes in 1-second intervals when drive or enclosure indicator is set to On in Dell Storage Manager Client.

With the drive indicator, the containing drawer fault LED will also flash. With the enclosure indicator, all drives' and both drawers' fault LEDs will flash.

SCv2080 Storage System Drive Numbering

In the SCv2080 storage system, the drive slots are numbered 1–42 in the top drawer and 43–84 in the bottom drawer. Dell Storage Manager Client identifies drives as *XX-YY*, where *XX* is the number of the unit ID of the storage system, and *YY* is the drive position inside the storage system.

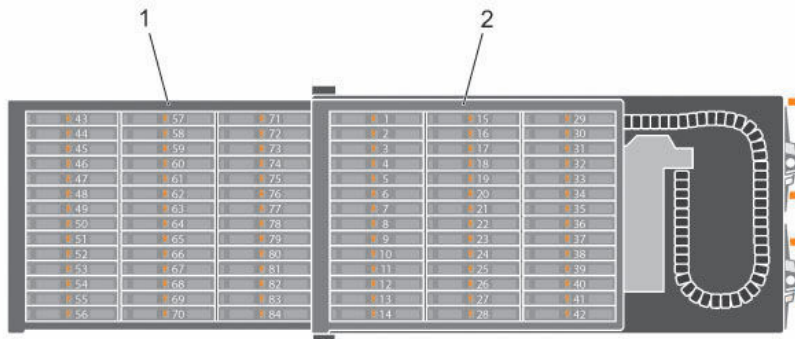

Figure 16. SCv2080 Storage System Drawers and Drive Numbering

1. Bottom drawer viewed from above
2. Top drawer viewed from above

SC180 Expansion Enclosure Overview

The SC180 is a 5U SAS expansion enclosure that supports up to 84 internal 3.5-inch hard drives installed in a two-drawer, three-row, 14-column configuration.

The SC180 expansion enclosure ships with two redundant power supply units, five redundant cooling fans, and two redundant enclosure management modules (EMMs).

SC180 Expansion Enclosure Front-Panel Features and Indicators

The SC180 front panel displays the expansion enclosure status.

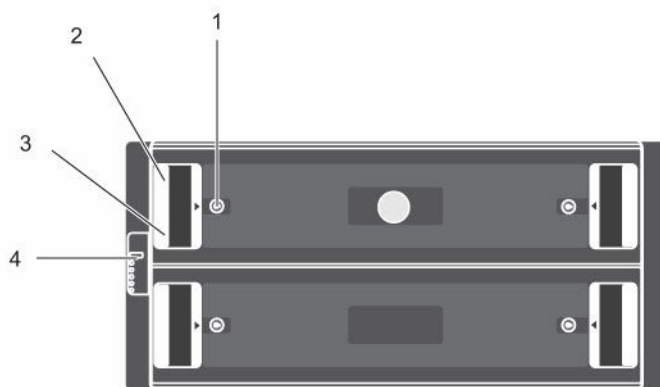













Figure 17. SC180 Expansion Enclosure Front-Panel Features and Indicators

Item	Name	Panel	Description
1	Drawer-specific anti-tamper locks		Locks the drawer shut using a Torx T20 screwdriver until the red arrows point to the locked icon (away from the center of the chassis).
2	Drawer-specific left and right side status indicators		<ul style="list-style-type: none"> • Sideplane OK/Power Good <ul style="list-style-type: none"> – Off — Sideplane card or cable fault – Green — Sideplane card and cable are functional (though a fault may be indicated by one or more of the following LEDs)
			<ul style="list-style-type: none"> • Drawer Fault <ul style="list-style-type: none"> – Amber — Sideplane card fault or drive failure causing loss of availability or redundancy
			<ul style="list-style-type: none"> • Logical Fault <ul style="list-style-type: none"> – Amber (steady) — Host indicated drive fault – Amber (flashing) — Arrays in impacted state
			<ul style="list-style-type: none"> • Cable Fault <ul style="list-style-type: none"> – Amber — Cable fault
3	Drawer-specific left and right side expansion enclosure activity indicators		Activity Bar Graph — Six variable-intensity LEDs dynamically displaying access of the drives in that specific drawer
4	Status indicator for storage system		<ul style="list-style-type: none"> • Unit ID Display — Numerical display primarily used to display the unit identification number • Input Switch — Not used • Power On/Standby <ul style="list-style-type: none"> – Off — Expansion enclosure does not have power – Green — Expansion enclosure is on (operational) – Amber — Expansion enclosure is in standby mode (not operational)
			<ul style="list-style-type: none"> • Module Fault <ul style="list-style-type: none"> – Amber — Hardware fault (an LED may be lit on a PSU, drawer, DDIC, fan module, or I/O module indicating the part at fault)
			<ul style="list-style-type: none"> • Logical Status: <ul style="list-style-type: none"> – Amber — Change of status or fault from something other than the storage system itself (this status is typically associated with a disk drive as indicated by its own fault LED)
			<ul style="list-style-type: none"> • Drawer 1 Fault

Item	Name	Panel	Description
			<ul style="list-style-type: none"> Amber — Drive, cable, or sideplane fault has occurred in drawer 1
			<ul style="list-style-type: none"> Drawer 2 Fault Amber — Drive, cable, or sideplane fault has occurred in drawer 2
			NOTE: Both drawer fault LEDs (and all contained DDIC LEDs) will flash when the expansion enclosure indicator is set to On in Storage Manager Client.

SC180 Expansion Enclosure Back-Panel Features and Indicators

The SC180 back panel shows power, connectivity, and fault indicators.

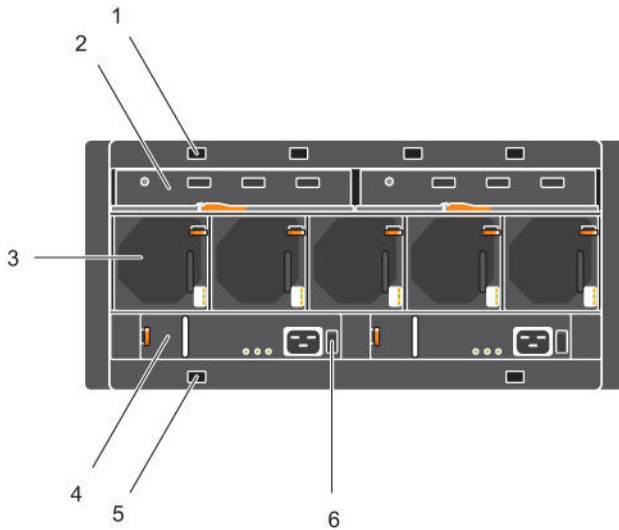

Figure 18. SC180 Expansion Enclosure Back-Panel Features and Indicators

Item	Name	Icon	Description
1	Optional cable retention positions (4)	—	Locations for optional cable retention brackets.
2	Expansion Enclosure Modules (2)	—	Each EMM contains SAS ports and status indicators.
3	Cooling fans (5)	—	Fans that provide cooling for the expansion enclosure.
4	Power supply units (2)	—	2.8 kW power supply that provides power for the expansion enclosure.
5	Optional cable retention positions (4)	—	Locations for optional cable retention brackets.
6	Power switch (2)	—	Controls power for the expansion enclosure. There is one switch for each power supply.

SC180 Expansion Enclosure EMM Features and Indicators

An SC180 includes two enclosure management modules (EMMs) in two Storage Bridge Bay (SBB) interface slots.

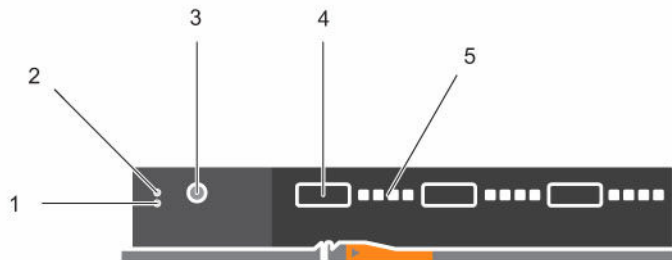



Figure 19. SC180 Expansion Enclosure EMM Features and Indicators

Item	Control/Feature	Icon	Description
1	Fault LED		<ul style="list-style-type: none"> Off — Module OK Amber — Module fault
2	Power LED		<ul style="list-style-type: none"> Green (steady) — Module OK Green (flashing) — Vital product data (VPD) fault Off — Module fault
3	Console port	—	Not for customer use
4	SAS ports	—	Connects to a storage controller.
5	SAS activity indicators	—	There are four SAS PHYs per SAS port. <ul style="list-style-type: none"> Off: SAS PHY is not connected Steady green: SAS PHY is connected, but no activity Blinking green: SAS PHY is not connected plus activity

SC180 Expansion Enclosure Fan Module Features and Indicators

The SC180 includes five fan modules in five interface slots.

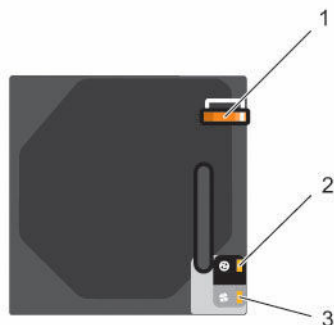



Figure 20. SC180 Expansion Enclosure Fan Module Features and Indicators

Item	Control/Feature	Icon	Description
1	Release latch	—	Press the release latch to remove the fan module.
2	Module OK		Green — Module OK
3	Fan fault		Amber — Loss of communication with the fan module, or reported fan speed is out of tolerance

SC180 Expansion Enclosure PSU Features and Indicators

The SC180 includes two power supply units (PSUs) in two interface slots.

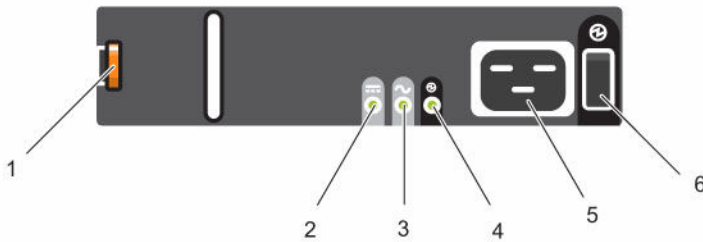





Figure 21. SC180 Expansion Enclosure PSU Features and Indicators

Item	Control/Feature	Icon	Description
1	Release latch	—	Press the release latch to remove the PSU.
2	PSU fault		<ul style="list-style-type: none"> • Amber (steady) — PSU fault, PSU not supplying power • Amber (flashing) — PSU firmware is downloading
3	AC fault+		<ul style="list-style-type: none"> • Amber (steady) — AC power is not detected • Amber (flashing) — PSU firmware is downloading
4	Power OK		<ul style="list-style-type: none"> • Green (steady) — This PSU is providing power • Green (flashing) — AC power is present, but this PSU is in standby mode (the other PSU is providing power)
5	Power outlet	—	Power outlet for the storage system.
6	Power switch	—	Controls power for the storage system.

If all three LEDs are in the same state, the following separate and unique conditions are indicated:

- If all three LEDs are off, then there is neither PSU has AC power.
- If all three LEDs are on, then the General Enclosure Management (GEM) software has lost communication with the PSU.

SC180 Expansion Enclosure Drives

Dell Enterprise hard disk drives (HDDs) and Dell Enterprise solid-state drives (eSSDs) are the only drives that can be installed in SC180 Expansion Enclosures. If a non-Dell Enterprise drive is installed, the Storage Center prevents the drive from being managed. Each drive is installed in a Disk Drive In Carrier (DDIC), and each DDIC includes one status indicator.

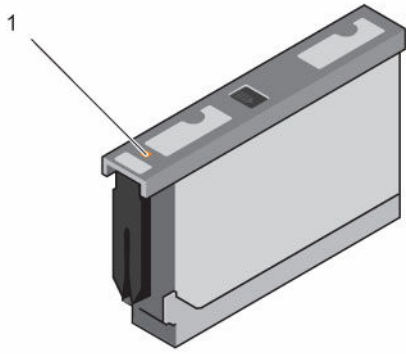

Figure 22. DDIC and Status Indicator

Item	Feature	Indicator Code
1	DDIC fault indicator	Amber — Drive fault Amber (flashing) — Flashes in 1-second intervals when the drive or enclosure indicator is enabled

SC180 Expansion Enclosure Drive Numbering

The drives in an SC180 are installed in a two-drawer, three-row, 14-column configuration.

The drive slots are numbered 1–42 in the top drawer and 43–84 in the bottom drawer. The Storage Center identifies drives as XX-YY, where XX is the unit ID of the expansion enclosure, and YY is the drive position inside the expansion enclosure.

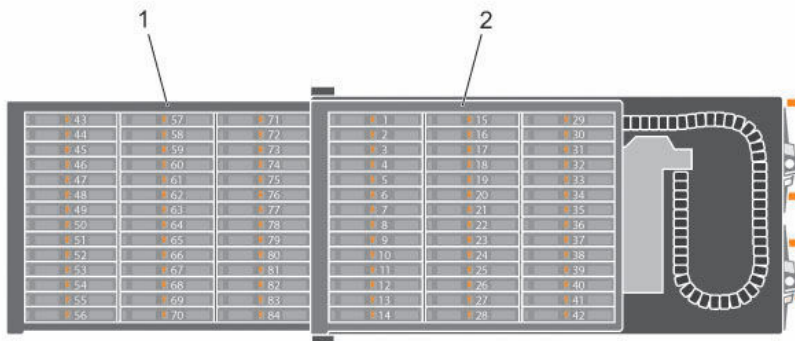

Figure 23. Hard Drive Drawers and Numbering

1. Bottom drawer
2. Top drawer



Install the Storage Center Hardware

This section describes how to unpack the Storage Center equipment, prepare for the installation, mount the equipment in a rack, and install the drives.

Unpack and Inventory the Storage Center Equipment

Unpack the storage system and identify the items in your shipment.

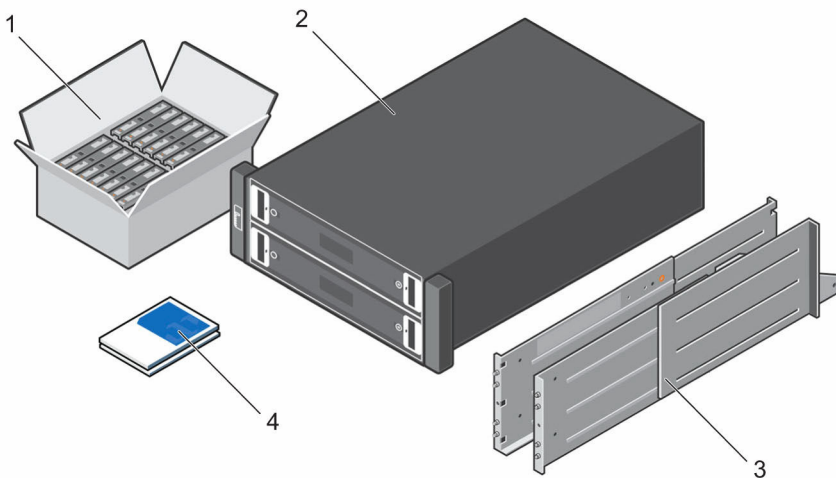

Figure 24. SCv2080 Storage System Components

- | | |
|----------------|-------------------|
| 1. Hard drives | 2. Storage system |
| 3. Rack rails | 4. Documentation |

Prepare the Installation Environment

Make sure that the environment is ready for installing the Storage Center.

- **Rack Space** — The rack must have enough space to accommodate the storage system chassis, expansion enclosures, and switches.
- **Power** — Power must be available in the rack, and the power delivery system must meet the requirements of the Storage Center.
- **Connectivity** — The rack must be wired for connectivity to the management network and any networks that carry front-end I/O from the Storage Center to servers.

Safety Precautions

Always follow these safety precautions to avoid injury and damage to Storage Center equipment.

If equipment described in this section is used in a manner not specified by Dell, the protection provided by the equipment could be impaired. For your safety and protection, observe the rules described in the following sections.

NOTE: See the safety and regulatory information that shipped with each Storage Center component. Warranty information is included within this document or as a separate document.



Installation Safety Precautions

Follow these safety precautions:

- Dell recommends that only individuals with rack-mounting experience install the SCv2080 in a rack.
- You need at least two people to lift the storage system chassis from the shipping box and three people to install it in the rack. The empty chassis weighs approximately 62 kg (137 lbs).
- Make sure the storage system is always fully grounded to prevent damage from electrostatic discharge.
- When handling the storage system hardware, use an electrostatic wrist guard (not included) or a similar form of protection.

The chassis must be mounted in a rack. The following safety requirements must be considered when the chassis is being mounted:

- The rack construction must be capable of supporting the total weight of the installed chassis. The design should incorporate stabilizing features suitable to prevent the rack from tipping or being pushed over during installation or in normal use.
- When loading a rack with chassis, fill from the bottom up; empty from the top down.
- To avoid danger of the rack toppling over, slide only one chassis out of the rack at a time.
- The storage system must be operated with low-pressure rear exhaust installation (back pressure created by rack doors and obstacles not to exceed 5 Pascals [0.5 mm water gauge]).

Electrical Safety Precautions

Always follow electrical safety precautions to avoid injury and damage to Storage Center equipment.

 **WARNING: Disconnect power from the storage system when removing or installing components that are not hot-swappable. When disconnecting power, first power down the storage system using the storage client and then unplug the power cords from the power supplies in the storage system and storage system.**

- Provide a suitable power source with electrical overload protection. All Storage Center components must be grounded before applying power. Make sure that a safe electrical earth connection can be made to power supply cords. Check the grounding before applying power.
- The plugs on the power supply cords are used as the main disconnect device. Make sure that the socket outlets are located near the equipment and are easily accessible.
- Know the locations of the equipment power switches and the room's emergency power-off switch, disconnection switch, or electrical outlet.
- Do not work alone when working with high-voltage components.
- Use rubber mats specifically designed as electrical insulators.
- Do not remove covers from the power supply unit. Disconnect the power connection before removing a power supply from the storage system.
- Do not remove a faulty power supply unless you have a replacement model of the correct type ready for insertion. A faulty power supply must be replaced with a fully operational module power supply within 24 hours.
- Unplug the storage system chassis before you move it or if you think it has become damaged in any way. When powered by multiple AC sources, disconnect all power sources for complete isolation.

Electrostatic Discharge Precautions

Always follow electrostatic discharge (ESD) precautions to avoid injury and damage to Storage Center equipment.

Electrostatic discharge (ESD) is generated by two objects with different electrical charges coming into contact with each other. The resulting electrical discharge can damage electronic components and printed circuit boards. Follow these guidelines to protect your equipment from ESD:

- Dell recommends that you always use a static mat and static strap while working on components in the interior of the storage system chassis.
- Observe all conventional ESD precautions when handling plug-in modules and components.
- Use a suitable ESD wrist or ankle strap.
- Avoid contact with backplane components and module connectors.
- Keep all components and printed circuit boards (PCBs) in their antistatic bags until ready for use.

General Safety Precautions

Always follow general safety precautions to avoid injury and damage to Storage Center equipment.

- Keep the area around the storage system chassis clean and free of clutter.
- Place any system components that have been removed away from the storage system chassis or on a table so that they are not in the way of other people.
- While working on the storage system chassis, do not wear loose clothing such as neckties and unbuttoned shirt sleeves. These items can come into contact with electrical circuits or be pulled into a cooling fan.
- Remove any jewelry or metal objects from your body. These items are excellent metal conductors that can create short circuits and harm you if they come into contact with printed circuit boards or areas where power is present.
- Do not lift the storage system chassis by the handles of the power supply units (PSUs). They are not designed to hold the weight of the entire chassis, and the chassis cover could become bent.
- Before moving the storage system chassis, remove the PSUs to minimize weight.
- Do not remove drives until you are ready to replace them.

 **NOTE: To ensure proper storage system cooling, hard drive blanks must be installed in any hard drive slot that is not occupied.**

Installing the Storage System in a Rack

Install the SCv2080 storage system and other Storage Center system components in a rack.

About this task

 **NOTE: Mount the storage system in a manner that allows for expansion in the rack and prevents the rack from becoming top-heavy.**

 **WARNING: If you plan to install the storage system above the lower 20U of a rack, a customer-provided mechanical lift must be used to avoid injury.**

Steps

1. Determine where to mount the storage system in the rack and mark the location at the front and rear of the rack.

 **NOTE: The storage system and expansion enclosures each require 5U of rack space for installation.**

2. Loosen the four circled screws on the inside of each rail.



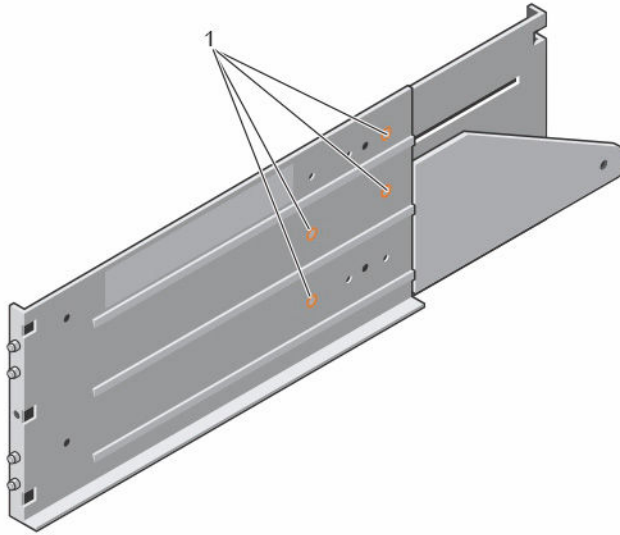

Figure 25. Inside of rail

1. Screws to loosen

3. Position one of the rails at the marked location at the front of the rack and insert the four rail pins into the pin holes.

NOTE: Dell recommends using two people to install the rail, one at the front of the rack and one at the back.

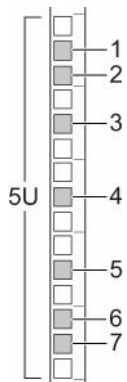

Figure 26. Hole Locations for the Rail at the Front of the Rack

- | | |
|--------------------------------|-----------------------------|
| 1. Chassis mounting screw hole | 2. Pin hole |
| 3. Pin hole | 4. Rack mounting screw hole |
| 5. Pin hole | 6. Pin hole |
| 7. Chassis mounting screw hole | |

4. Insert a screw into the rack mounting screw hole at the front of the rack and tighten the screw to secure the rail to the rack.

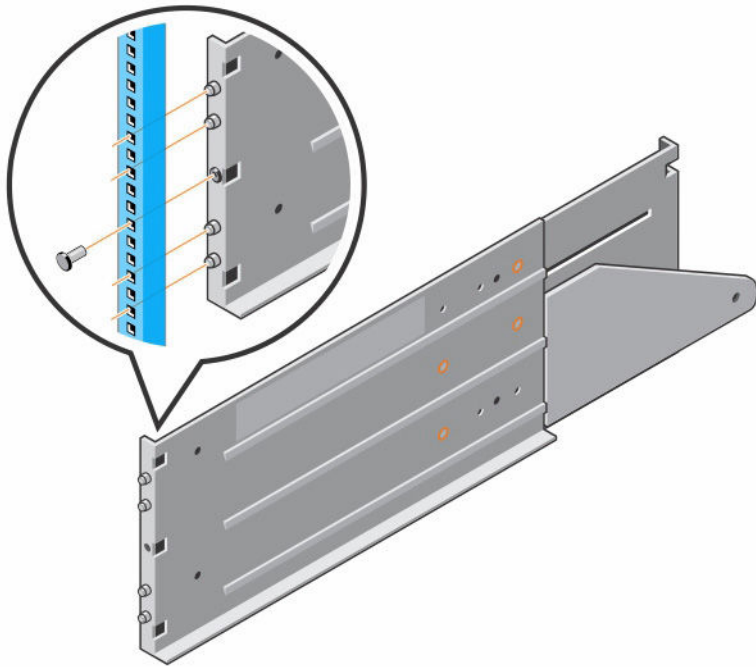

Figure 27. Insert the Screw into the Rack Mounting Screw Hole

5. Extend the rail to fit the rack.

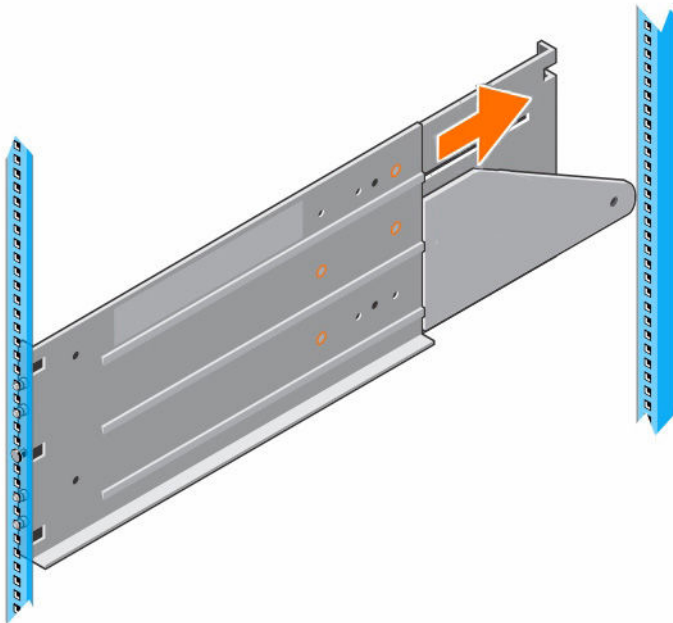

Figure 28. Extend the Rail

6. At the rear of the rack, insert the four rail pins into the pin holes.

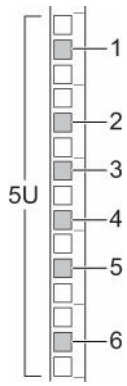

Figure 29. Hole Locations for the Rail at the Rear of the Rack

- | | |
|-----------------------------|-----------------------------|
| 1. Rack mounting screw hole | 2. Pin hole |
| 3. Pin hole | 4. Pin hole |
| 5. Pin hole | 6. Rack mounting screw hole |
7. Insert screws into the top and bottom rack mounting screw holes at the back of the rack, then tighten the screws to secure the rail to the rack.

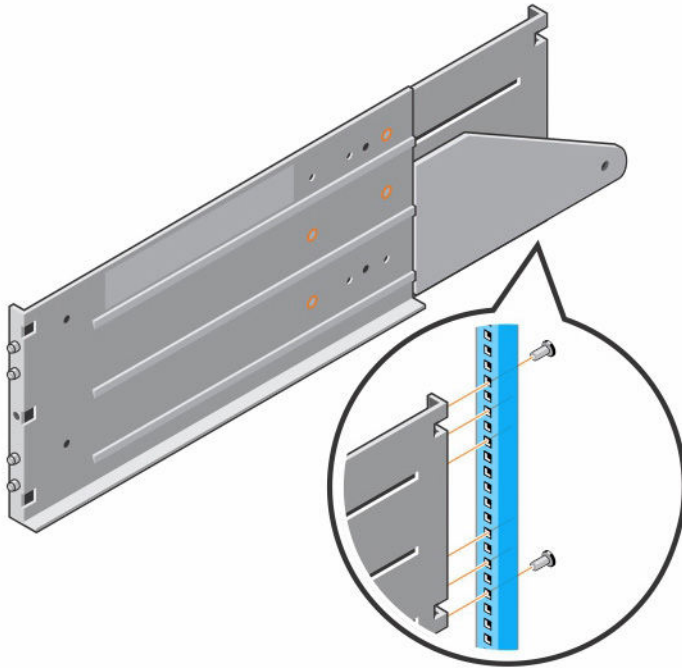

Figure 30. Insert the Screws into the Rack Mounting Screw Holes

8. Tighten the four circled screws that were loosened in Step 2.
9. Repeat the previous steps for the second rail.
10. Slide the storage system chassis onto the rails.

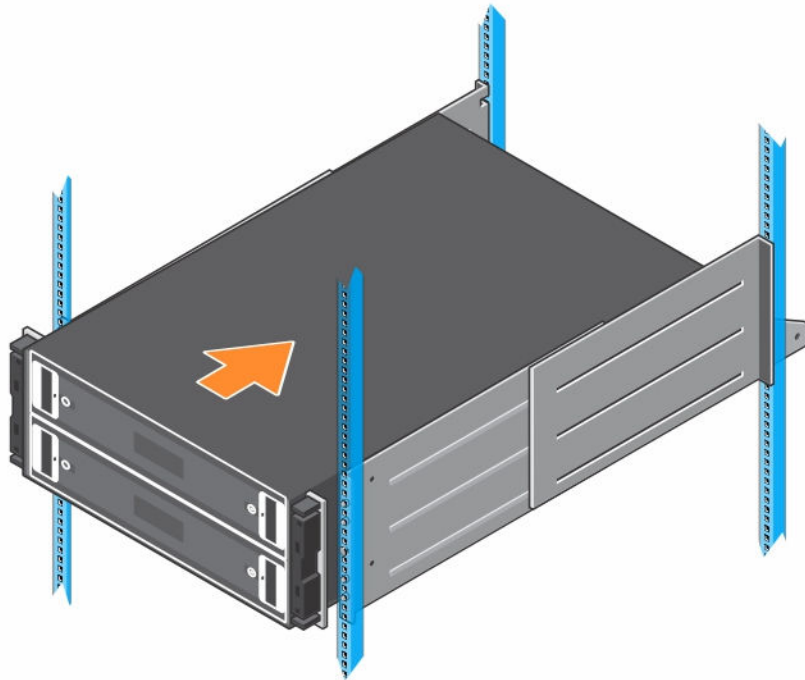

Figure 31. Mount the SCv2080 Storage System Chassis

11. Secure the storage system chassis to the front of the rack using the mounting screws within each chassis ear.
 - a. Remove the plastic covers from the chassis ears.
 - b. Insert screws into the top and bottom rack mounting screw holes, then tighten the screws to secure the chassis to the rack.
 - c. Replace the plastic covers on the chassis ears.

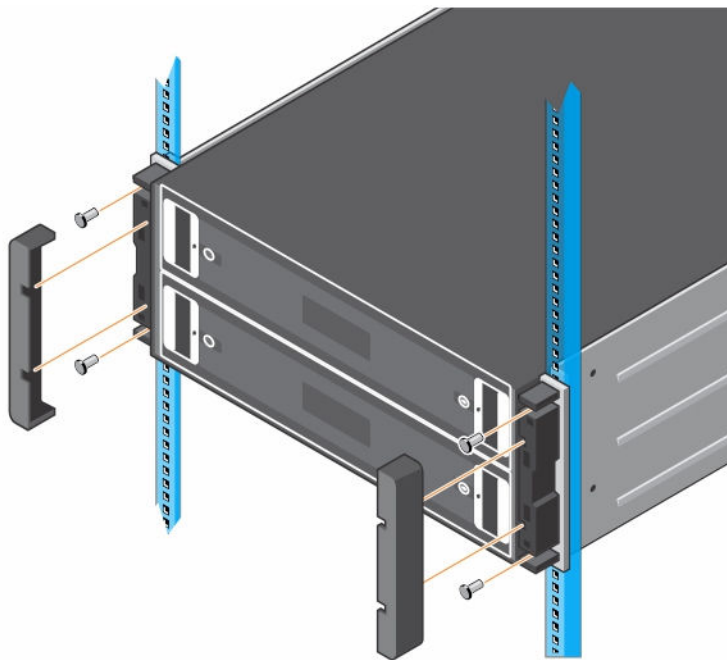

Figure 32. Secure the Chassis to the Rack

12. Use screws to secure the storage system chassis to the rear of the rail on each side.



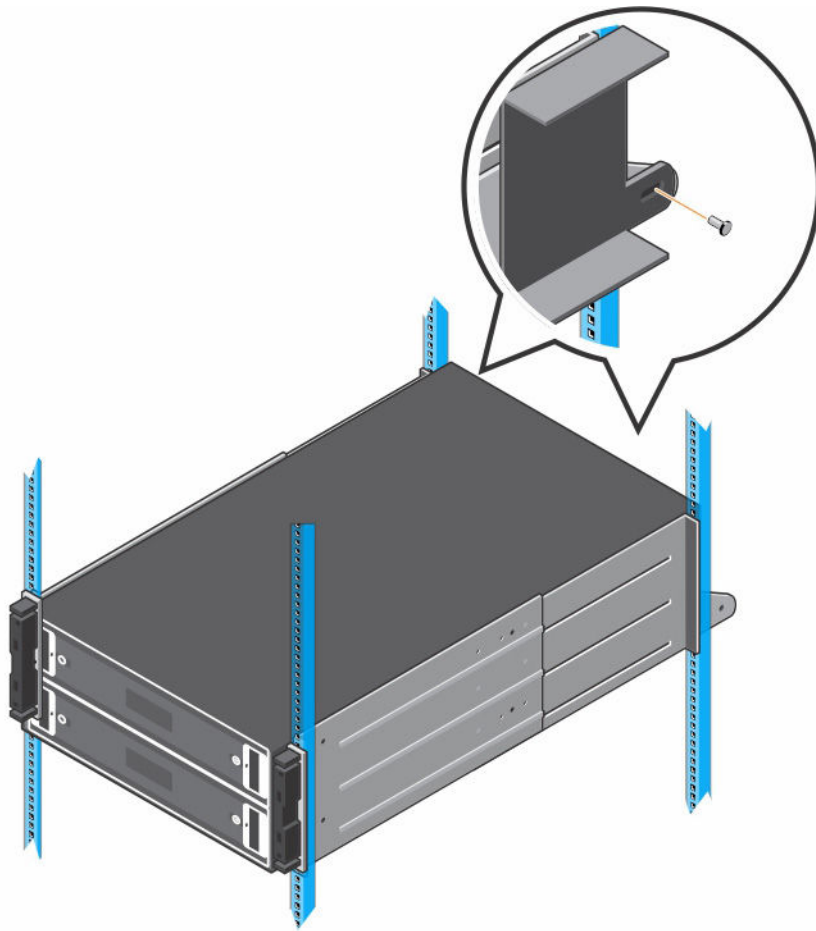

Figure 33. Secure the Chassis to the Rail

13. If the Storage Center system includes an expansion enclosure, mount the expansion enclosure above the storage system. See the instructions included with the expansion enclosure for detailed steps.

Installing the Hard Drives

Hard drives are connected to the backplane of the drawers using Disk Drive in Carrier (DDIC) hard drive carriers.

About this task

The minimum number of drives in an SCv2080 storage system or SC180 expansion enclosure is 28 (one full, front row in the top drawer and one full, front row in the bottom drawer).

Steps

1. Open the top drawer.

CAUTION: If the storage system or expansion enclosure operates for too long (depending on altitude) with a drawer open, the storage system or expansion enclosure may overheat, causing a power failure and data loss. Such use may invalidate the warranty.

- a. Push and hold both drawer latches toward the center of the drawer.
- b. Pull the drawer all the way out until it stops.

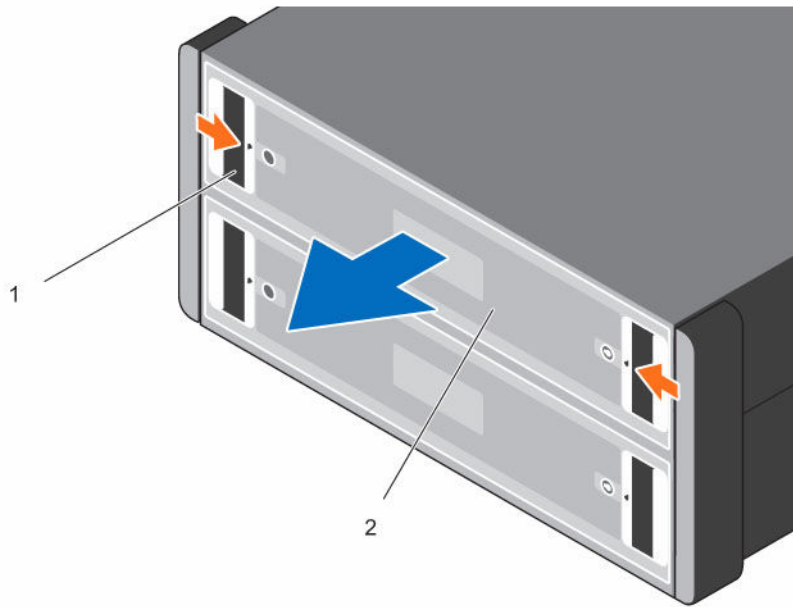

Figure 34. Opening the Drawer

1. Drawer latches

2. Top drawer

2. Insert each drive into the drawer, one at a time.

△ CAUTION: To maintain proper airflow, the drawers must be populated with drives in whole rows (each drawer has three rows of 14 drives). The number of populated rows between drawers must not differ by more than one. Populate the rows from the front to the rear of the drawer.

- a. Hold the drive by the DDIC and slide it most of the way into the slot.
- b. Using both hands (thumbs and forefingers), apply downward pressure firmly and equally across the DDIC.

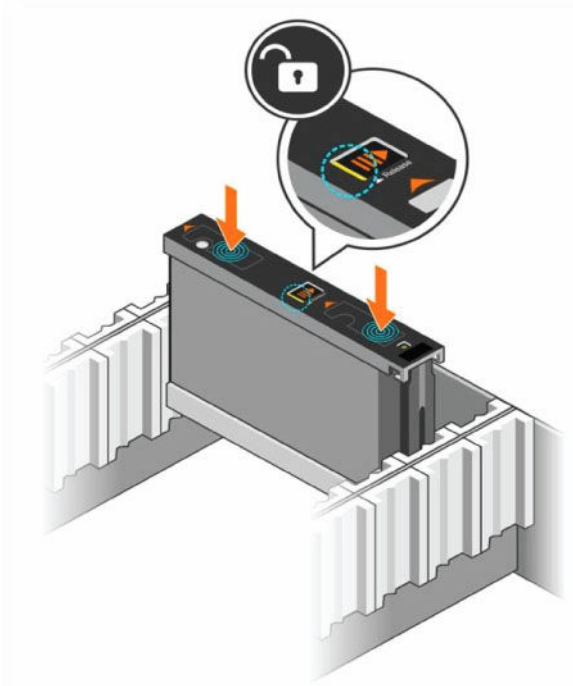

Figure 35. Inserting a Drive into the Drawer

- c. While maintaining downward pressure, slide the top plate of the DDIC toward the back of the drawer until it clicks into place.

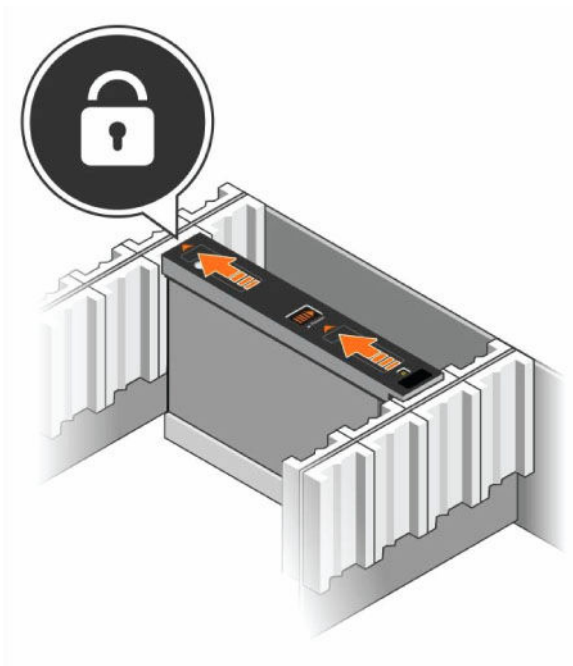

Figure 36. Securing a Drive in the Drawer

NOTE: It is possible for a drive to appear seated but not be fully locked into position, eventually causing it to dislodge itself. After installing a drive, check the release button in the center of the DDIC. If the drive is NOT fully locked into position, a yellow line will be visible underneath the arrow button. If the yellow line is visible, remove the drive and re-install it.

⚠ CAUTION: If the DDIC fails to latch, do not use it and request a replacement from Dell Technical Support. If a faulty DDIC unlatches within a closed drawer, you may not be able to open the drawer.

3. Close the drawer after adding all of the DDICs.
 - a. Locate the two lock-release buttons situated midway along the runners on each side of the drawer.
 - b. Press the lock-release buttons inward and use your body to push the drawer toward the chassis until the locks disengage.
 - c. Place your hands on the front bezel and continue to push the drawer inward until the bezel is flush with the chassis and the front drawer locks engage.

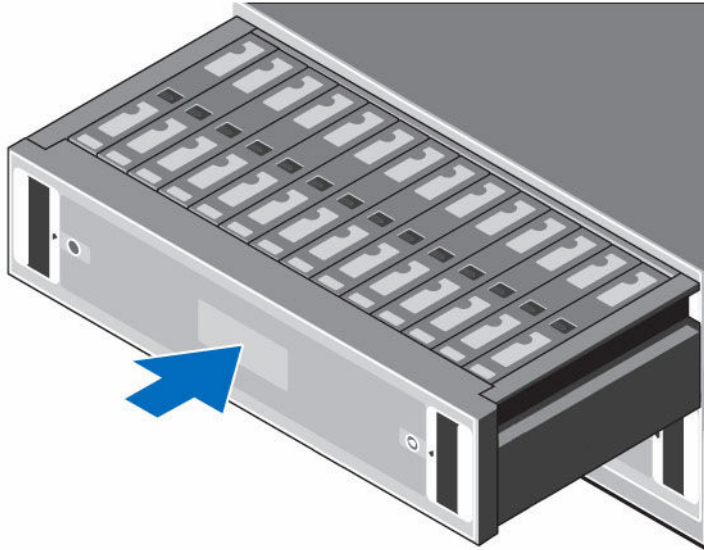

Figure 37. Closing the Drawer

⚠ WARNING: Keep fingers clear of the chassis as the drawer is closed.

4. Repeat the previous steps for the bottom drawer.
5. To maintain proper airflow, populate the remaining rows in the following order:
 - a. Top drawer middle row
 - b. Bottom drawer middle row
 - c. Top drawer back row
 - d. Bottom drawer back row

Connect the Front-End Cabling

Front-end cabling refers to the connections between the storage system and external devices such as host servers or another Storage Center.

Front-end connections can be made using Fibre Channel, iSCSI, or SAS interfaces. Dell recommends connecting the storage system to host servers using the most redundant option available.

Types of Redundancy for Front-End Connections

Front-end redundancy is achieved by eliminating single points of failure that could cause a server to lose connectivity to the Storage Center.

Depending on how the Storage Center is cabled and configured, the following types of redundancy are available.

Table 1. Redundancy and Failover Behavior

Redundancy	Failover Behavior
Asymmetric Logical Unit Access (ALUA)	If a storage controller becomes unavailable, all the standby paths on the other storage controller become active.
Port redundancy	If a single port becomes unavailable, the port can move to another available port in the same fault domain.
Storage controller redundancy	If a storage controller becomes unavailable, the ports on the offline storage controller can move to the available storage controller.
Path redundancy	When multiple paths are available from a server to a storage system, a server configured for multipath I/O (MPIO) can use multiple paths for I/O. If a path becomes unavailable, the server continues to use the remaining available paths.

Port Redundancy

To allow for port redundancy, two front-end ports on a storage controller must be connected to the same switch or server.

Fault domains group front-end ports that are connected to the same network. Ports that belong to the same fault domain can fail over to each other because they have the same connectivity.

If a port becomes unavailable because it is disconnected or a hardware failure has occurred, the port moves over to another port in the same fault domain.

Storage Controller Redundancy

To allow for storage controller redundancy, a front-end port on each storage controller must be connected to the same switch or server.

If a storage controller becomes unavailable, the front-end ports on the offline storage controller move over to the ports (in the same fault domain) on the available storage controller.

Fault Domains

Fault domains group front-end ports that are connected to the same network. Ports that belong to the same fault domain can fail over to each other because they have the same connectivity.

Dell recommends configuring at least two connections from each storage controller to each fault domain.

Multipath I/O

MPIO allows a server to use multiple paths for I/O if they are available.

MPIO software offers redundancy at the path level. MPIO typically operates in a round-robin manner by sending packets first down one path and then the other. If a path becomes unavailable, MPIO software continues to send packets down the functioning path. MPIO is required to enable redundancy for servers connected to a Storage Center with SAS front-end connectivity.

 **NOTE: MPIO is operating-system specific, and it loads as a driver on the server or it is part of the server operating system.**

MPIO Behavior

The server must have at least two FC, iSCSI, or SAS ports to use MPIO.

When MPIO is configured, a server can send I/O to multiple ports on the same storage controller.

MPIO Configuration Instructions for Host Servers

To use MPIO, configure MPIO on the host server.

If a Dell Storage Manager Client wizard is used to configure host server access to the Storage Center, the Dell Storage Manager Client attempts to automatically configure MPIO with best practices.

 **NOTE: Compare the host server settings applied by the Dell Storage Manager Client wizard against the latest Dell Storage Center Best Practices document on the Dell TechCenter site (<http://en.community.dell.com/techcenter/storage/>).**

Table 2. MPIO Configuration Documents

Operating System	Document with MPIO Instructions
Linux	<ul style="list-style-type: none">• <i>Dell Storage Center with Red Hat Enterprise Linux (RHEL) 6x Best Practices</i>• <i>Dell Storage Center with Red Hat Enterprise Linux (RHEL) 7x Best Practices</i>• <i>Dell Compellent Best Practices: Storage Center with SUSE Linux Enterprise Server 11</i>
VMware vSphere 5.x	<ul style="list-style-type: none">• <i>Dell Storage Center Best Practices with VMware vSphere 5.x</i>• <i>Dell Storage Center Best Practices with VMware vSphere 6.x</i>
Windows Server 2008, 2008 R2, 2012, and 2012 R2	<i>Dell Storage Center: Microsoft Multipath I/O Best Practices</i>

Cabling SAN-Attached Host Servers

An SCv2080 storage system with Fibre Channel or iSCSI front-end ports connects to host servers through Fibre Channel or Ethernet switches.

- A storage system with Fibre Channel front-end ports connects to one or more FC switches, which connect to one or more host servers.
- A storage system with iSCSI front-end ports connects to one or more Ethernet switches, which connect to one or more host servers.



Connecting to Fibre Channel Host Servers

Choose the Fibre Channel connectivity option that best suits the front-end redundancy requirements and network infrastructure.

Preparing Host Servers

Install the Fibre Channel host bus adapters (HBAs), install the drivers, and make sure that the latest supported firmware is installed.

About this task

- Contact your solution provider for a list of supported Fibre Channel HBAs.
- Refer to the *Dell Storage Compatibility Matrix* for a list of supported Fibre Channel HBAs.

Steps

1. Install Fibre Channel HBAs in the host servers.



NOTE: Do not install Fibre Channel HBAs from different vendors in the same server.

2. Install supported drivers for the HBAs and make sure that the HBAs have the latest supported firmware.
3. Use the Fibre Channel cabling diagrams to cable the host servers to the switches. Connecting host servers directly to the storage system without using Fibre Channel switches is not supported.

Two Fibre Channel Fabrics with Dual 16 Gb 2-Port Storage Controllers

Use two Fibre Channel (FC) fabrics to prevent an unavailable port, switch, or storage controller from causing a loss of connectivity between host servers and a storage system with dual 16 Gb 2-port storage controllers.

About this task

This configuration includes two fault domains, two FC fabrics, and two FC switches. The storage controllers connect to each FC switch using one FC connection.

- If a physical port or FC switch becomes unavailable, the storage system is accessed from the switch in the other fault domain.
- If a storage controller becomes unavailable, the virtual ports on the offline storage controller move to the physical ports on the other storage controller.

Steps

1. Connect each server to both FC fabrics.
2. Connect fault domain 1 (shown in orange) to fabric 1.
 - Storage controller 1: port 1 to FC switch 1
 - Storage controller 2: port 1 to FC switch 1
3. Connect fault domain 2 (shown in blue) to fabric 2.
 - Storage controller 1: port 2 to FC switch 2
 - Storage controller 2: port 2 to FC switch 2

Example

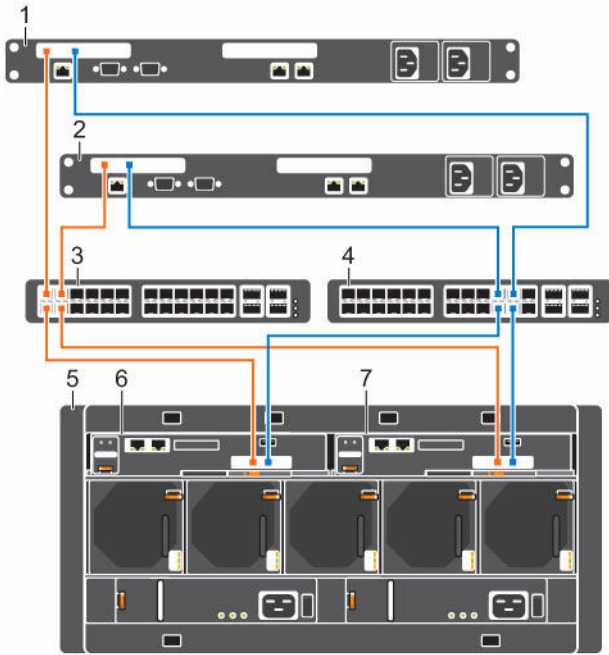

Figure 38. Storage System with Dual 16 Gb Storage Controllers and Two FC Switches

- | | |
|---------------------------------|---------------------------------|
| 1. Server 1 | 2. Server 2 |
| 3. FC switch 1 (fault domain 1) | 4. FC switch 2 (fault domain 2) |
| 5. Storage system | 6. Storage controller 1 |
| 7. Storage controller 2 | |

Next steps

Install or enable MPIO on the host servers.

NOTE: After the Storage Center configuration is complete, run the host access wizard to configure host server access and apply MPIO best practices. For the latest best practices, see the Dell Storage Center Best Practices document on the Dell TechCenter site (<http://en.community.dell.com/techcenter/storage/>).

Two Fibre Channel Fabrics with Dual 8 Gb 4-Port Storage Controllers

Use two Fibre Channel (FC) fabrics to prevent an unavailable port, switch, or storage controller from causing a loss of connectivity between host servers and a storage system with dual 8 Gb 4-port storage controllers.

About this task

This configuration includes two fault domains, two FC fabrics, and two FC switches. The storage controllers connect to each FC switch using two FC connections.

- If a physical port becomes unavailable, the virtual port moves to another physical port in the same fault domain on the same storage controller.
- If an FC switch becomes unavailable, the storage system is accessed from the switch in the other fault domain.
- If a storage controller becomes unavailable, the virtual ports on the offline storage controller move to the physical ports on the other storage controller.

Steps

1. Connect each server to both FC fabrics.
2. Connect fault domain 1 (shown in orange) to fabric 1.
 - Storage controller 1: port 1 to FC switch 1
 - Storage controller 1: port 3 to FC switch 1
 - Storage controller 2: port 1 to FC switch 1



- Storage controller 2: port 3 to FC switch 1
3. Connect fault domain 2 (shown in blue) to fabric 2.
- Storage controller 1: port 2 to FC switch 2
 - Storage controller 1: port 4 to FC switch 2
 - Storage controller 2: port 2 to FC switch 2
 - Storage controller 2: port 4 to FC switch 2

Example

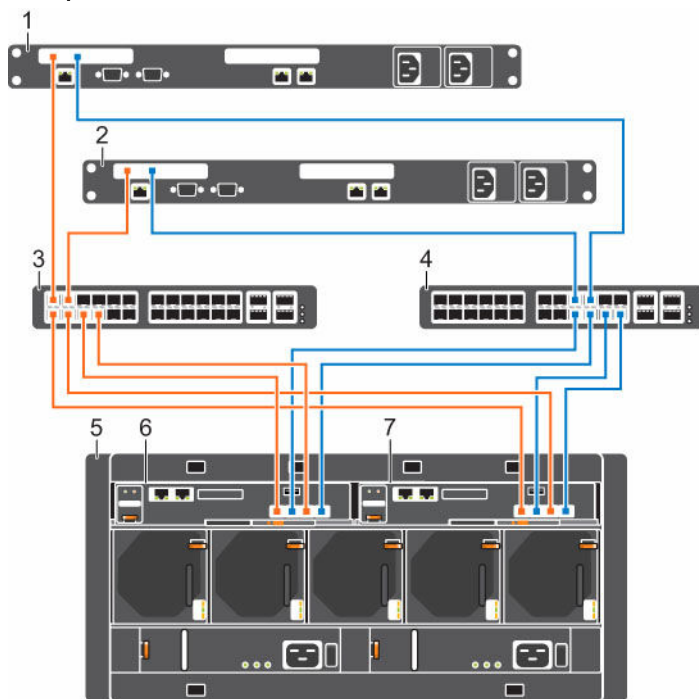

Figure 39. Storage System with Dual 8 Gb Storage Controllers and Two FC Switches

- | | |
|---------------------------------|---------------------------------|
| 1. Server 1 | 2. Server 2 |
| 3. FC switch 1 (fault domain 1) | 4. FC switch 2 (fault domain 2) |
| 5. Storage system | 6. Storage controller 1 |
| 7. Storage controller 2 | |

Next steps

Install or enable MPIIO on the host servers.

NOTE: After the Storage Center configuration is complete, run the host access wizard to configure host server access and apply MPIIO best practices. For the latest best practices, see the Dell Storage Center Best Practices document on the Dell TechCenter site (<http://en.community.dell.com/techcenter/storage/>).

One Fibre Channel Fabric with Dual 16 Gb 2-Port Storage Controllers

Use one Fibre Channel (FC) fabric to prevent an unavailable port or storage controller from causing a loss of connectivity between the host servers and a storage system with dual 16 Gb 2-port storage controllers.

About this task

This configuration includes one fault domain, one fabric, and one FC switch. Each storage controller connects to the FC switch using two FC connections.

- If a physical port becomes unavailable, the virtual port moves to another port in the fault domain on the same storage controller
- If a storage controller becomes unavailable, the virtual ports on the offline storage controller move to physical ports on the other storage controller.

NOTE: This configuration is vulnerable to switch unavailability, which results in a loss of connectivity between the host servers and storage system.

Steps

1. Connect each server to the FC fabric.
2. Connect fault domain 1 (shown in orange) to the fabric.
 - Storage controller 1: port 1 to the FC switch
 - Storage controller 1: port 2 to the FC switch
 - Storage controller 2: port 1 to the FC switch
 - Storage controller 2: port 2 to the FC switch

Example

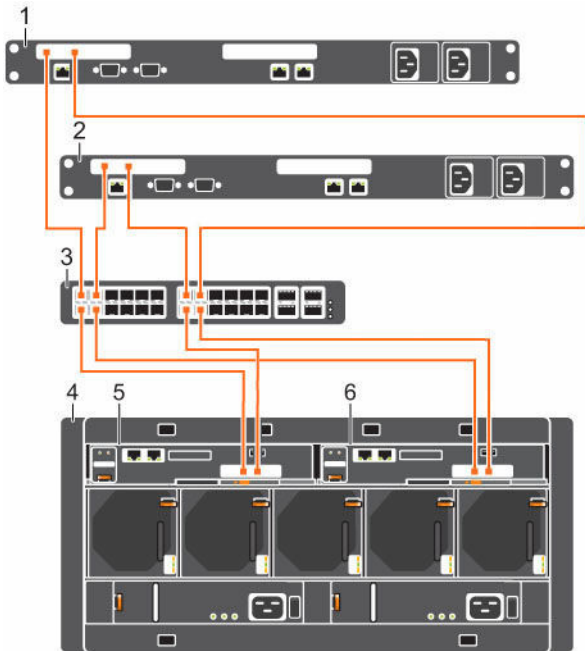

Figure 40. Storage System with Dual 16 Gb Storage Controllers and One FC Switch

- | | |
|-------------------------------|-------------------------|
| 1. Server 1 | 2. Server 2 |
| 3. FC switch (Fault domain 1) | 4. Storage system |
| 5. Storage controller 1 | 6. Storage controller 2 |

Next steps

Install or enable MPIO on the host servers.

NOTE: After the Storage Center configuration is complete, run the host access wizard to configure host server access and apply MPIO best practices. For the latest best practices, see the Dell Storage Center Best Practices document on the Dell TechCenter site (<http://en.community.dell.com/techcenter/storage/>).

One Fibre Channel Fabric with Dual 8 Gb 4-Port Storage Controllers

Use one Fibre Channel (FC) fabric to prevent an unavailable port or storage controller from causing a loss of connectivity between the host servers and a storage system with dual 8 Gb 4-port storage controllers.

About this task

This configuration includes two fault domains, one fabric, and one FC switch. Each storage controller connects to the FC switch using four FC connections.

- If a physical port becomes unavailable, the virtual port moves to another physical port in the same fault domain on the same storage controller.
- If a storage controller becomes unavailable, the virtual ports on the offline storage controller move to the physical ports on the other storage controller.



NOTE: This configuration is vulnerable to switch unavailability, which results in a loss of connectivity between the host servers and the storage system.

Steps

1. Connect each server to the FC fabric.
2. Connect fault domain 1 (shown in orange) to the fabric.
 - Storage controller 1: port 1 to the FC switch
 - Storage controller 1: port 3 to the FC switch
 - Storage controller 2: port 1 to the FC switch
 - Storage controller 2: port 3 to the FC switch
3. Connect fault domain 2 (shown in blue) to the fabric.
 - Storage controller 1: port 2 to the FC switch
 - Storage controller 1: port 4 to the FC switch
 - Storage controller 2: port 2 to the FC switch
 - Storage controller 2: port 4 to the FC switch

Example

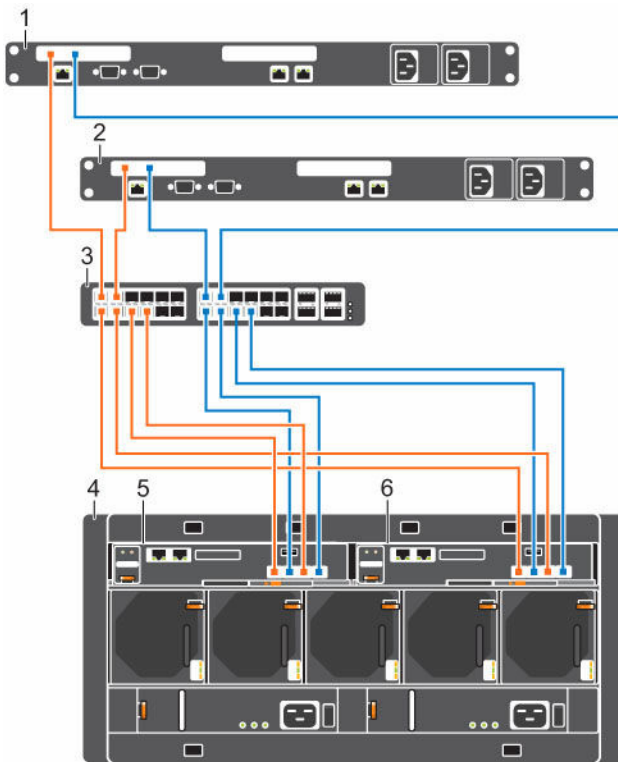

Figure 41. Storage System with Dual 8 Gb Storage Controllers and One FC Switch

- | | |
|--|-------------------------|
| 1. Server 1 | 2. Server 2 |
| 3. FC switch (fault domain 1 and fault domain 2) | 4. Storage system |
| 5. Storage controller 1 | 6. Storage controller 2 |

Next steps

Install or enable MPIO on the host servers.

NOTE: After the Storage Center configuration is complete, run the host access wizard to configure host server access and apply MPIO best practices. For the latest best practices, see the Dell Storage Center Best Practices document on the Dell TechCenter site (<http://en.community.dell.com/techcenter/storage/>).

Using SFP+ Transceiver Modules

An SCv2080 storage system with 16 Gb Fibre Channel storage controllers uses short range small-form-factor pluggable (SFP+) transceiver modules.

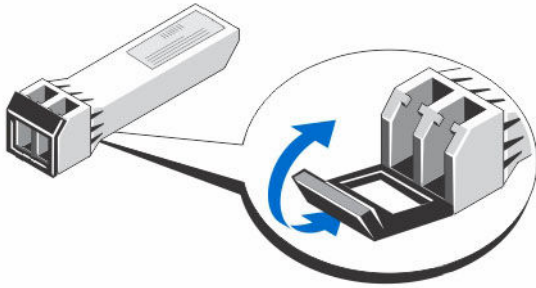

Figure 42. SFP+ Transceiver Module with a Bail Clasp Latch

The SFP+ transceiver modules are installed into the front-end ports of a storage controller. Fiber-optic cables are connected from the SFP+ transceiver modules in a storage controller to SFP+ transceiver modules in Fibre Channel switches.

Guidelines for Using SFP+ Transceiver Modules

The SCv2080 storage system supports the use of SFP+ transceiver modules for 16 Gb FC connectivity.

Before installing SFP+ transceiver modules and fiber-optic cables, read the following guidelines.

⚠ CAUTION: When handling static-sensitive devices, take precautions to avoid damaging the product from static electricity.

- Use only Dell-supported SFP+ transceiver modules with the SCv2080. Other generic SFP+ transceiver modules are not supported and may not work with the SCv2080.
- The SFP+ transceiver module housing has an integral guide key that is designed to prevent you from inserting the transceiver module incorrectly.
- Use minimal pressure when inserting an SFP+ transceiver module into an FC port. Forcing the SFP+ transceiver module into a port may damage the transceiver module or the port.
- The SFP+ transceiver module must be installed into a port before you connect the fiber-optic cable.
- The fiber-optic cable must be removed from the SFP+ transceiver module before you remove the transceiver module from the port.

Install an SFP+ Transceiver Module

Complete the following steps to install an SFP+ transceiver module in a 16 Gb FC storage controller.

About this task

Read the following cautions and information before installing an SFP+ transceiver module.

⚠ WARNING: To reduce the risk of injury from laser radiation or damage to the equipment, observe the following precautions:

- Do not open any panels, operate controls, make adjustments, or perform procedures to a laser device other than those specified in this document.
- Do not stare into the laser beam.

⚠ CAUTION: Transceiver modules can be damaged by electrostatic discharge (ESD). To prevent ESD damage to the transceiver module, take the following precautions:

- Wear an antistatic discharge strap while handling transceiver modules.
- Place transceiver modules in antistatic packing material when transporting or storing them.



Steps

1. Position the transceiver module so that the key is oriented correctly to the port in the storage controller.

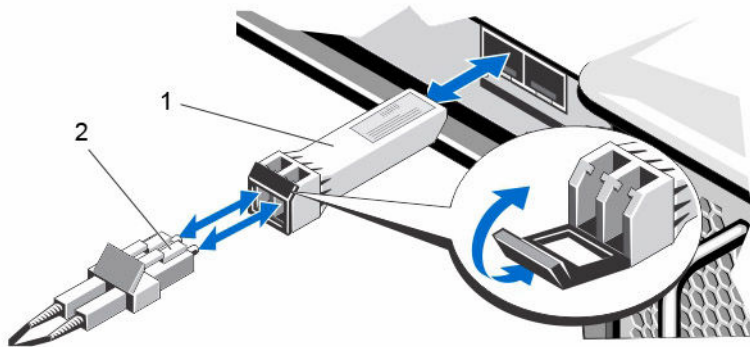

Figure 43. Install the SFP+ Transceiver Module

1. SFP+ transceiver module
2. Fiber-optic cable connector

2. Insert the transceiver module into the port until it is firmly seated and the latching mechanism clicks. The transceiver modules are keyed so that they can only be inserted with the correct orientation. If a transceiver module does not slide in easily, ensure that it is correctly oriented.

CAUTION: To reduce the risk of damage to the equipment, do not use excessive force when inserting the transceiver module.

3. Position fiber-optic cable so that the key (the ridge on one side of the cable connector) is aligned with the slot in the transceiver module.

CAUTION: Touching the end of a fiber-optic cable damages the cable. Whenever a fiber-optic cable is not connected, replace the protective covers on the ends of the cable.

4. Insert the fiber-optic cable into the transceiver module until the latching mechanism clicks.
5. Insert the other end of the fiber-optic cable into the SFP+ transceiver module of a Fibre Channel switch.

Remove an SFP+ Transceiver Module

Complete the following steps to remove an SFP+ transceiver module from a 16 Gb FC storage controller.

Prerequisites

Use failover testing to make sure that the connection between host servers and the Storage Center remains up if the port is disconnected.

About this task

Read the following cautions and information before beginning removal or replacement procedures.

WARNING: To reduce the risk of injury from laser radiation or damage to the equipment, observe the following precautions.

- Do not open any panels, operate controls, make adjustments, or perform procedures to a laser device other than those specified in this document.
- Do not stare into the laser beam.

CAUTION: Transceiver modules can be damaged by electrostatic discharge (ESD). To prevent ESD damage to the transceiver module, take the following precautions:

- Wear an antistatic discharge strap while handling modules.
- Place modules in antistatic packing material when transporting or storing them.

Steps

1. Remove the fiber-optic cable that is inserted into the transceiver.
 - a. Make certain the fiber-optic cable is labeled before removing it.
 - b. Press the release clip on the bottom of the cable connector to remove the fiber-optic cable from the transceiver.

⚠ CAUTION: Touching the end of a fiber-optic cable damages the cable. Whenever a fiber-optic cable is not connected, replace the protective covers on the ends of the cables.

2. Open the transceiver module latching mechanism.
3. Grasp the bail clasp latch on the transceiver module and pull the latch out and down to eject the transceiver module from the socket.
4. Slide the transceiver module out of the port.

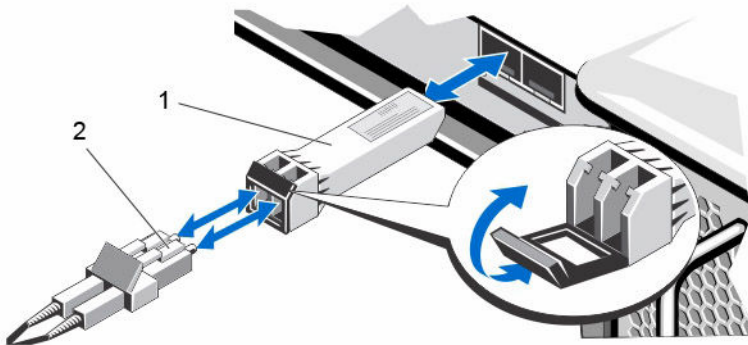

Figure 44. Remove the SFP+ Transceiver Module

1. SFP+ transceiver module

2. Fiber-optic cable connector

Fibre Channel Zoning

When using Fibre Channel for front-end connectivity, zones must be established to ensure that storage is visible to the servers. Use the zoning concepts discussed in this section to plan the front-end connectivity before starting to cable the storage system.

Dell recommends creating zones using a single initiator host port and multiple Storage Center ports.

WWN Zoning Guidelines

When WWN zoning is configured, a device may reside on any port, or change physical ports and still be visible, because the switch is seeking a WWN.

List of guidelines for WWN zoning.

- Include all Storage Center virtual World Wide Port Names (WWPNs) in a single zone.
- Include all Storage Center physical World Wide Port Names (WWPNs) in a single zone.
- For each host server HBA port, create a zone that includes the HBA port WWPN and multiple Storage Center virtual WWPNs on the same switch.
- For Fibre Channel replication from Storage Center system A to Storage Center system B:
 - Include all Storage Center physical WWPNs from system A and system B in a single zone.
 - Include all Storage Center physical WWPNs of system A and the virtual WWPNs of system B on the particular fabric.
 - Include all Storage Center physical WWPNs of system B and the virtual WWPNs of system A on the particular fabric.

✎ NOTE: Some ports may not be used or dedicated for replication, however ports that are used must be in these zones.

Labeling the Front-End Cables

Label the front-end cables to indicate the storage controller and port to which they are connected.

Prerequisites

Locate the front-end cable labels that shipped with the storage system.

About this task

Apply cable labels to both ends of each cable that connects a storage controller to a front-end fabric or network, or directly to host servers.



Steps

1. Starting with the top edge of the label, attach the label to the cable near the connector.

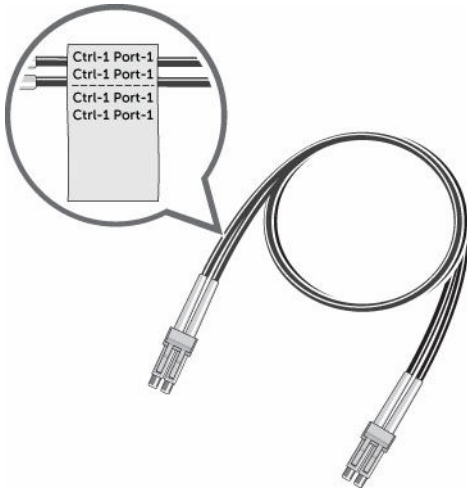

Figure 45. Attach Label to Cable

2. Wrap the label around the cable until it fully encircles the cable. The bottom of each label is clear so that it does not obscure the text.



Figure 46. Wrap Label Around Cable

3. Apply a matching label to the other end of the cable.

Connecting to iSCSI Host Servers

Choose the iSCSI connectivity option that best suits the front-end redundancy requirements and network infrastructure.

Preparing Host Servers

Install the iSCSI host bus adapters (HBAs) or iSCSI network adapters, install the drivers, and make sure that the latest supported firmware is installed.

- Contact your solution provider for a list of supported iSCSI HBAs.
- Refer to the *Dell Storage Compatibility Matrix* for a list of supported HBAs.
- If the host server is a Windows or Linux host:
 - a. Install the iSCSI HBAs or network adapters dedicated for iSCSI traffic in the host servers.

 **NOTE: Do not install iSCSI HBAs or network adapters from different vendors in the same server.**

- b. Install supported drivers for the HBAs or network adapters and make sure that the HBAs or network adapter have the latest supported firmware.
- c. Use the host operating system to assign IP addresses for each iSCSI port. The IP addresses must match the subnets for each fault domain.

 **CAUTION: Correctly assign IP addresses to the HBAs or network adapters. Assigning IP addresses to the wrong ports can cause connectivity issues.**

 **NOTE: If using jumbo frames, they must be enabled and configured on all devices in the data path, adapter ports, switches, and storage system.**

- d. Use the iSCSI cabling diagrams to cable the host servers to the switches. Connecting host servers directly to the storage system without using Ethernet switches is not supported.

• If the host server is a vSphere host:

- a. Install the iSCSI HBAs or network adapters dedicated for iSCSI traffic in the host servers.
- b. Install supported drivers for the HBAs or network adapters and make sure that the HBAs or network adapter have the latest supported firmware.
- c. If the host uses network adapters for iSCSI traffic, create a VMkernel port for each network adapter (1 VMkernel per vSwitch).
- d. Use the host operating system to assign IP addresses for each iSCSI port. The IP addresses must match the subnets for each fault domain.

 **CAUTION: Correctly assign IP addresses to the HBAs or network adapters. Assigning IP addresses to the wrong ports can cause connectivity issues.**

 **NOTE: If using jumbo frames, they must be enabled and configured on all devices in the data path, adapter ports, switches, and storage system.**

- e. If the host uses network adapters for iSCSI traffic, add the VMkernel ports to the iSCSI software initiator.
- f. Use the iSCSI cabling diagrams to cable the host servers to the switches. Connecting host servers directly to the storage system without using Ethernet switches is not supported.

Two iSCSI Networks with Dual 10 GbE 2-Port Storage Controllers

Use two iSCSI networks to prevent an unavailable port, switch, or storage controller from causing a loss of connectivity between the host servers and a storage system with dual 10 GbE 2-port storage controllers.

About this task

This configuration includes two fault domains, two iSCSI networks on separate subnets, and two Ethernet switches. The storage controllers connect to each Ethernet switch using one iSCSI connection.

- If a physical port or Ethernet switch becomes unavailable, the storage system is accessed from the switch in the other fault domain.
- If a storage controller becomes unavailable, the virtual ports on the offline storage controller move to the physical ports on the other storage controller.

Steps

1. Connect each server to both iSCSI networks.
2. Connect fault domain 1 (shown in orange) to iSCSI network 1.
 - Storage controller 1: port 1 to Ethernet switch 1
 - Storage controller 2: port 1 to Ethernet switch 1
3. Connect fault domain 2 (shown in blue) to iSCSI network 2.
 - Storage controller 1: port 2 to Ethernet switch 2
 - Storage controller 2: port 2 to Ethernet switch 2



Example

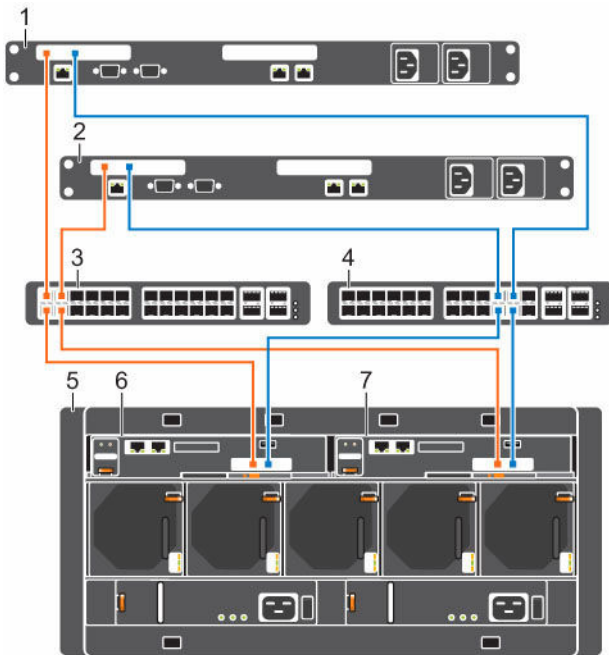

Figure 47. Storage System with Dual 10 GbE Storage Controllers and Two Ethernet Switches

- | | |
|---------------------------------------|---------------------------------------|
| 1. Server 1 | 2. Server 2 |
| 3. Ethernet switch 1 (fault domain 1) | 4. Ethernet switch 2 (fault domain 2) |
| 5. Storage system | 6. Storage controller 1 |
| 7. Storage controller 2 | |

Next steps

Install or enable MPIO on the host servers.

NOTE: After the Storage Center configuration is complete, run the host access wizard to configure host server access and apply MPIO best practices. For the latest best practices, see the Dell Storage Center Best Practices document on the Dell TechCenter site (<http://en.community.dell.com/techcenter/storage/>).

Two iSCSI Networks with Dual 1 GbE 4-Port Storage Controllers

Use two iSCSI networks to prevent an unavailable port, switch, or storage controller from causing a loss of connectivity between the host servers and a storage system with dual 1 GbE 4-port storage controllers.

About this task

This configuration includes two fault domains, two iSCSI networks on separate subnets, and two Ethernet switches. The storage controllers connect to each Ethernet switch using two iSCSI connections.

- If a physical port becomes unavailable, the virtual port moves to another physical port in the same fault domain on the same storage controller.
- If an Ethernet switch becomes unavailable, the storage system is accessed from the switch in the other fault domain.
- If a storage controller becomes unavailable, the virtual ports on the offline storage controller move to physical ports on the other storage controller.

Steps

1. Connect each server to both iSCSI networks.
2. Connect fault domain 1 (shown in orange) to iSCSI network 1.
 - Storage controller 1: port 1 to Ethernet switch 1
 - Storage controller 2: port 1 to Ethernet switch 1
 - Storage controller 1: port 3 to Ethernet switch 1

- Storage controller 2: port 3 to Ethernet switch 1
3. Connect fault domain 2 (shown in blue) to iSCSI network 2.
- Storage controller 1: port 2 to Ethernet switch 2
 - Storage controller 2: port 2 to Ethernet switch 2
 - Storage controller 1: port 4 to Ethernet switch 2
 - Storage controller 2: port 4 to Ethernet switch 2

Example

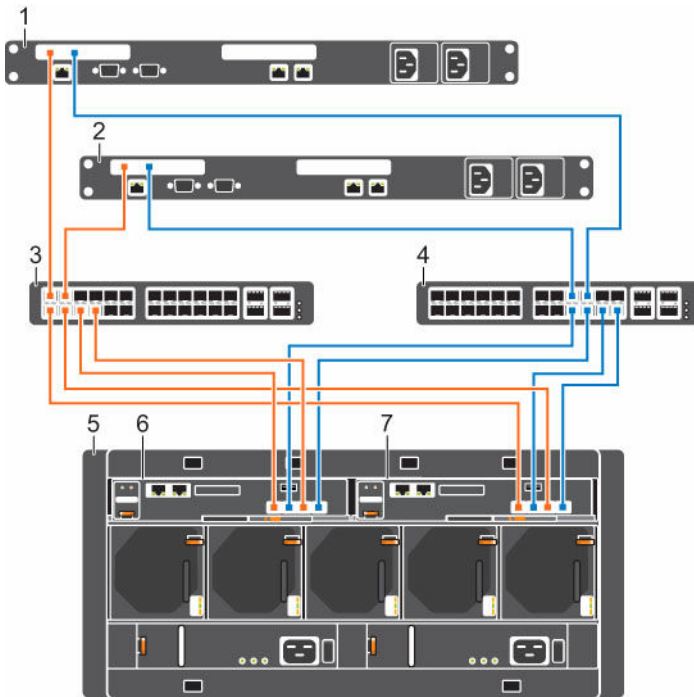

Figure 48. Storage System with Dual 1 GbE Storage Controllers and Two Ethernet Switches

- | | |
|---------------------------------------|---------------------------------------|
| 1. Server 1 | 2. Server 2 |
| 3. Ethernet switch 1 (fault domain 1) | 4. Ethernet switch 2 (fault domain 2) |
| 5. Storage system | 6. Storage controller 1 |
| 7. Storage controller 2 | |

Next steps

Install or enable MPIO on the host servers.

NOTE: After the Storage Center configuration is complete, run the host access wizard to configure host server access and apply MPIO best practices. For the latest best practices, see the Dell Storage Center Best Practices document on the Dell TechCenter site (<http://en.community.dell.com/techcenter/storage/>).

One iSCSI Network with Dual 10 GbE 2-Port Storage Controllers

Use one iSCSI network to prevent an unavailable port or storage controller from causing a loss of connectivity between the host servers and a storage system with dual 10 GbE 2-Port storage controllers.

About this task

This configuration includes one fault domain, one iSCSI network, and one Ethernet switch. Each storage controller connects to the Ethernet switch using two iSCSI connections.

- If a physical port becomes unavailable, the virtual port moves to another port in the fault domain.
- If a storage controller becomes unavailable, the virtual ports on the offline storage controller move to the physical ports on the other storage controller.



NOTE: This configuration is vulnerable to switch unavailability, which results in a loss of connectivity between the host servers and storage system.

Steps

1. Connect each server to the iSCSI network.
2. Connect fault domain 1 (shown in orange) to the iSCSI network.
 - Storage controller 1: port 1 to the Ethernet switch
 - Storage controller 1: port 2 to the Ethernet switch
 - Storage controller 2: port 1 to the Ethernet switch
 - Storage controller 2: port 2 to the Ethernet switch

Example

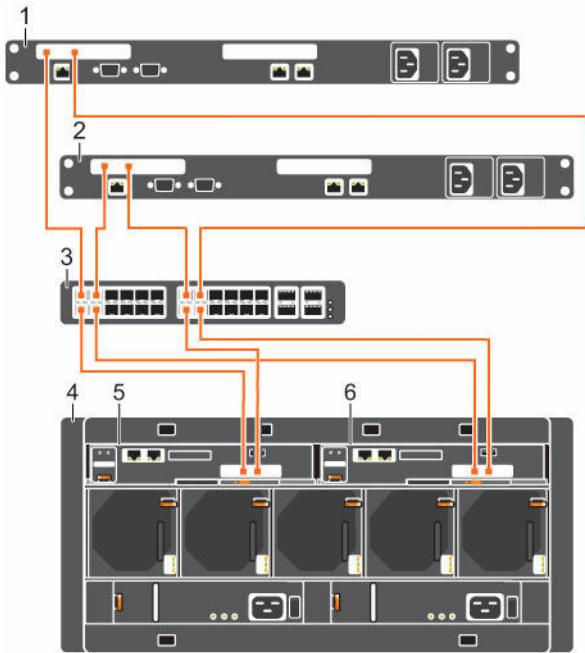

Figure 49. Storage System with Dual 10 GbE Storage Controllers and One Ethernet Switch

- | | |
|-------------------------------------|-------------------------|
| 1. Server 1 | 2. Server 2 |
| 3. Ethernet switch (Fault domain 1) | 4. Storage system |
| 5. Storage controller 1 | 6. Storage controller 2 |

Next steps

Install or enable MPIIO on the host servers.

NOTE: After the Storage Center configuration is complete, run the host access wizard to configure host server access and apply MPIIO best practices. For the latest best practices, see the Dell Storage Center Best Practices document on the Dell TechCenter site (<http://en.community.dell.com/techcenter/storage/>).

One iSCSI Network with Dual 1 GbE 4-Port Storage Controllers

Use one iSCSI network to prevent an unavailable port or storage controller from causing a loss of connectivity between the host servers and a storage system with dual 1 GbE 4-port storage controllers.

About this task

This configuration includes two fault domains, one iSCSI network, and one Ethernet switch. Each storage controller connects to the Ethernet switch using four iSCSI connections.

- If a physical port becomes unavailable, the virtual port moves to another physical port in the same fault domain on the same storage controller.
- If a storage controller becomes unavailable, the virtual ports on the offline storage controller move to the physical ports on the other storage controller.

NOTE: This configuration is vulnerable to switch unavailability, which results in a loss of connectivity between the host servers and the storage system.

Steps

1. Connect each server to the iSCSI network.
2. Connect fault domain 1 (shown in orange) to the iSCSI network.
 - Storage controller 1: port 1 to the Ethernet switch
 - Storage controller 1: port 3 to the Ethernet switch
 - Storage controller 2: port 1 to the Ethernet switch
 - Storage controller 2: port 3 to the Ethernet switch
3. Connect fault domain 2 (shown in blue) to the iSCSI network.
 - Storage controller 1: port 2 to the Ethernet switch
 - Storage controller 1: port 4 to the Ethernet switch
 - Storage controller 2: port 2 to the Ethernet switch
 - Storage controller 2: port 4 to the Ethernet switch

Example

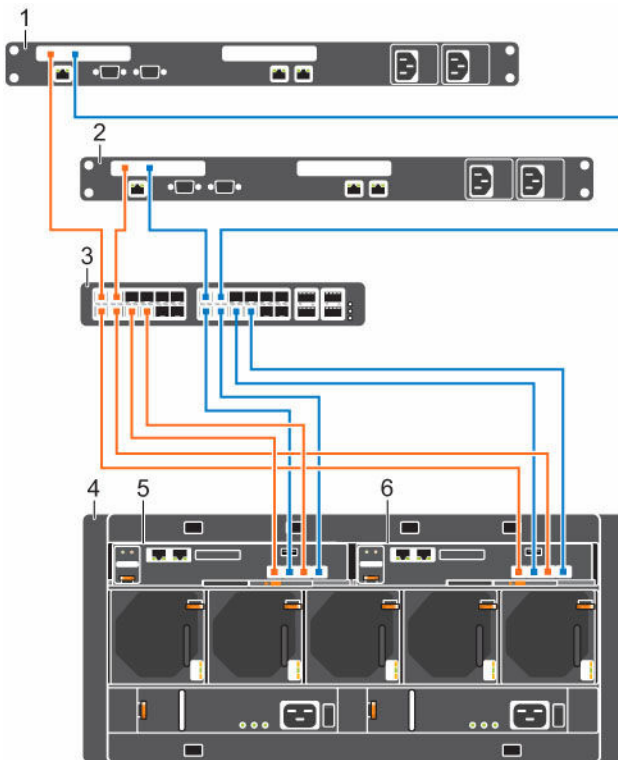

Figure 50. Storage System with Dual 1 GbE Storage Controllers and One Ethernet Switch

- | | |
|--|-------------------------|
| 1. Server 1 | 2. Server 2 |
| 3. Ethernet switch (fault domain 1 and fault domain 2) | 4. Storage system |
| 5. Storage controller 1 | 6. Storage controller 2 |

Next steps

Install or enable MPIIO on the host servers.

NOTE: After the Storage Center configuration is complete, run the host access wizard to configure host server access and apply MPIIO best practices. For the latest best practices, see the Dell Storage Center Best Practices document on the Dell TechCenter site (<http://en.community.dell.com/techcenter/storage/>).



Labeling the Front-End Cables

Label the front-end cables to indicate the storage controller and port to which they are connected.

Prerequisites

Locate the pre-made front-end cable labels that shipped with the storage system.

About this task

Apply cable labels to both ends of each cable that connects a storage controller to a front-end fabric or network, or directly to host servers.

Steps

1. Starting with the top edge of the label, attach the label to the cable near the connector.



Figure 51. Attach Label to Cable

2. Wrap the label around the cable until it fully encircles the cable. The bottom of each label is clear so that it does not obscure the text



Figure 52. Wrap Label Around Cable

3. Apply a matching label to the other end of the cable.

Cabling Direct-Attached Host Servers

An SCv2080 storage system with front-end SAS ports connects directly to host servers. Each host bus adapter (HBA) can attach to one SAS fault domain.

Preparing Host Servers

On each host server, install the SAS host bus adapters (HBAs), install the drivers, and make sure that the latest supported firmware is installed.

About this task

 **NOTE: Refer to the *Dell Storage Compatibility Matrix* for a list of supported SAS HBAs.**

Steps

1. Install the SAS HBAs in the host servers.

 **NOTE: Do not install SAS HBAs from different vendors in the same server.**

2. Install supported drivers for the HBAs and make sure that the HBAs have the latest supported firmware installed.
3. Use the SAS cabling diagram to cable the host servers directly to the storage system.

 **NOTE: If deploying vSphere hosts, configure only one host at a time.**

SAS Virtual Port Mode

To provide redundancy in SAS virtual port mode, the front-end ports on each storage controller must be directly connected to the server.

In SAS virtual port mode, a volume is active on only one storage controller, but it is visible to both storage controllers. Asymmetric Logical Unit Access (ALUA) controls the path that a server uses to access a volume.

If a storage controller becomes unavailable, the volume becomes active on the other storage controller. The state of the paths on the available storage controller are set to Active/Optimized and the state of the paths on the other storage controller are set to Standby. When the storage controller becomes available again and the ports are rebalanced, the volume moves back to its preferred storage controller and the ALUA states are updated.

If a SAS path becomes unavailable, the Active/Optimized volumes on that path become active on the other storage controller. The state of the failed path for those volumes is set to Standby and the state of the active path for those volumes is set to Active/Optimized.

 **NOTE: Failover in SAS virtual port mode occurs within a single fault domain. Therefore, a server must have both connections in the same fault domain. For example, if a server is connected to SAS port 2 on one storage controller, it must be connected to SAS port two on the other storage controller. If a server is not cabled correctly when a storage controller or SAS path becomes unavailable, access to the volume is lost.**

Two Servers Connected to Dual 12 Gb 4-Port SAS Storage Controllers

A storage system with four 12 Gb front-end SAS ports on each storage controller can connect up to two host servers, if each host server has two SAS HBAs with dual SAS ports.

About this task

This configuration includes four fault domains spread across both storage controllers. The storage controllers are connected to each host server using four SAS connections.

If a storage controller becomes unavailable, all of the standby paths on the other storage controller become active.

Steps

1. Connect fault domain 1 (shown in orange) to host server 1.
 - a. Connect a SAS cable from storage controller 1: port 1 to the first SAS HBA on host server 1.
 - b. Connect a SAS cable from storage controller 2: port 1 to the first SAS HBA on host server 1.
2. Connect fault domain 2 (shown in blue) to host server 1.
 - a. Connect a SAS cable from storage controller 1: port 2 to the second SAS HBA on host server 1.
 - b. Connect a SAS cable from storage controller 2: port 2 to the second SAS HBA on host server 1.
3. Connect fault domain 3 (shown in gray) to host server 2.



- a. Connect a SAS cable from storage controller 1: port 3 to the first SAS HBA on host server 2.
 - b. Connect a SAS cable from storage controller 2: port 3 to the first SAS HBA on host server 2.
4. Connect fault domain 4 (shown in red) to host server 2.
- a. Connect a SAS cable from storage controller 1: port 4 to the second SAS HBA on host server 2
 - b. Connect a SAS cable from storage controller 2: port 4 to the second SAS HBA on host server 2

Example

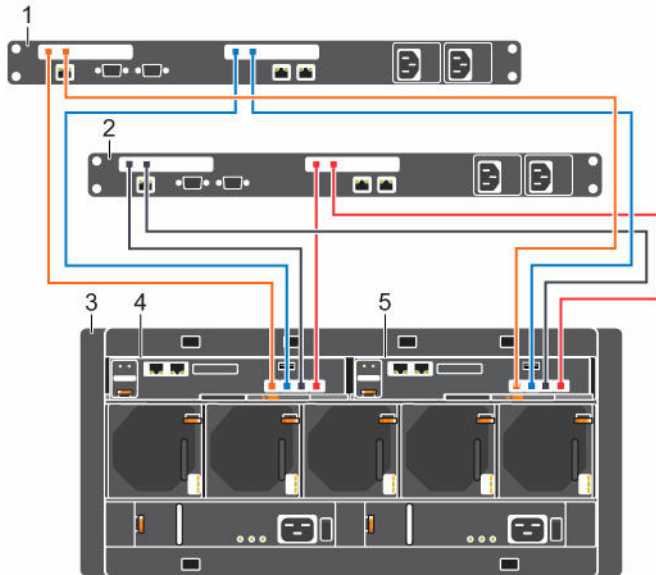

Figure 53. Storage System with Dual 12 Gb SAS Storage Controllers Connected to Two Host Servers

- | | |
|-------------------------|-------------------------|
| 1. Server 1 | 2. Server 2 |
| 3. Storage system | 4. Storage controller 1 |
| 5. Storage controller 2 | |

Next steps

Install or enable MPIIO on the host servers.

NOTE: After the Storage Center configuration is complete, run the host access wizard to configure host server access and apply MPIIO best practices. For the latest best practices, see the Dell Storage Center Best Practices document on the Dell TechCenter site (<http://en.community.dell.com/techcenter/storage/>).

Four Servers Connected to Dual 12 Gb 4-Port SAS Storage Controllers

A storage system with four 12 Gb front-end SAS ports on each storage controller can connect to up to four host servers, if each host server has one HBA with dual SAS ports.

About this task

This configuration includes four fault domains spread across both storage controllers. The storage controllers are connected to each host server using two SAS connections.

If a storage controller becomes unavailable, all of the standby paths on the other storage controller become active.

Steps

1. Connect fault domain 1 (shown in orange) to host server 1.
 - a. Connect a SAS cable from storage controller 1: port 1 to the SAS HBA on host server 1.
 - b. Connect a SAS cable from storage controller 2: port 1 to the SAS HBA on host server 1.
2. Connect fault domain 2 (shown in blue) to host server 2.
 - a. Connect a SAS cable from storage controller 1: port 2 to the SAS HBA on host server 2.
 - b. Connect a SAS cable from storage controller 2: port 2 to the SAS HBA on host server 2.

3. Connect fault domain 3 (shown in gray) to host server 3.
 - a. Connect a SAS cable from storage controller 1: port 3 to the SAS HBA on host server 3.
 - b. Connect a SAS cable from storage controller 2: port 3 to the SAS HBA on host server 3.
4. Connect fault domain 4 (shown in red) to host server 4.
 - a. Connect a SAS cable from storage controller 1: port 4 to the SAS HBA on host server 4.
 - b. Connect a SAS cable from storage controller 2: port 4 to the SAS HBA on host server 4.

Example

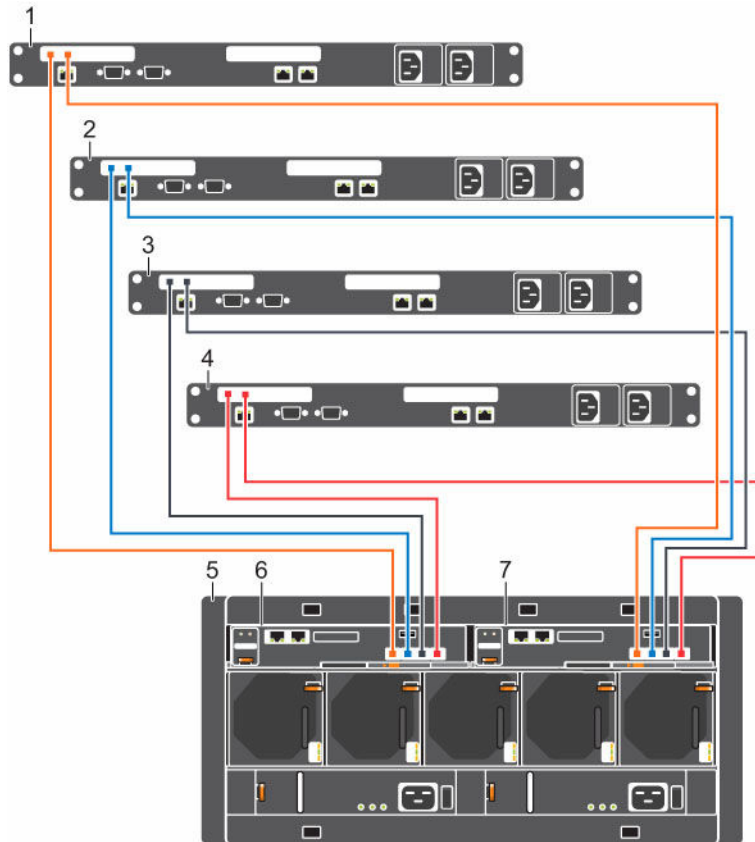

Figure 54. Storage System with Dual 12 Gb SAS Storage Controllers Connected to Four Host Servers

- | | |
|-------------------------|-------------------------|
| 1. Server 1 | 2. Server 2 |
| 3. Server 3 | 4. Server 4 |
| 5. Storage system | 6. Storage controller 1 |
| 7. Storage controller 2 | |

Next steps

Install or enable MPIO on the host servers.

NOTE: After the Storage Center configuration is complete, run the host access wizard to configure host server access and apply MPIO best practices. For the latest best practices, see the Dell Storage Center Best Practices document on the Dell TechCenter site (<http://en.community.dell.com/techcenter/storage/>).

Labeling the Front-End Cables

Label the front-end cables to indicate the storage controller and port to which they are connected.

Prerequisites

Locate the pre-made front-end cable labels that shipped with the storage system.

About this task

Apply cable labels to both ends of each cable that connects a storage controller to a front-end fabric or network, or directly to host servers.



Steps

1. Starting with the top edge of the label, attach the label to the cable near the connector.



Figure 55. Attach Label to Cable

2. Wrap the label around the cable until it fully encircles the cable. The bottom of each label is clear so that it does not obscure the text.



Figure 56. Wrap Label Around Cable

3. Apply a matching label to the other end of the cable.

Cabling the Ethernet Management Port

To manage Storage Center, the Ethernet management (MGMT) port of each storage controller must be connected to an Ethernet switch that is part of the management network.

About this task

The management port provides access to the storage system software and is used to send emails, alerts, SNMP traps, and SupportAssist diagnostic data. The management port also provides access to the baseboard management controller (BMC) software.

Steps

1. Connect the Ethernet switch to the corporate/management network (shown in green).
2. Connect the Ethernet management port on storage controller 1 to the Ethernet switch.
3. Connect the Ethernet management port on storage controller 2 to the Ethernet switch.

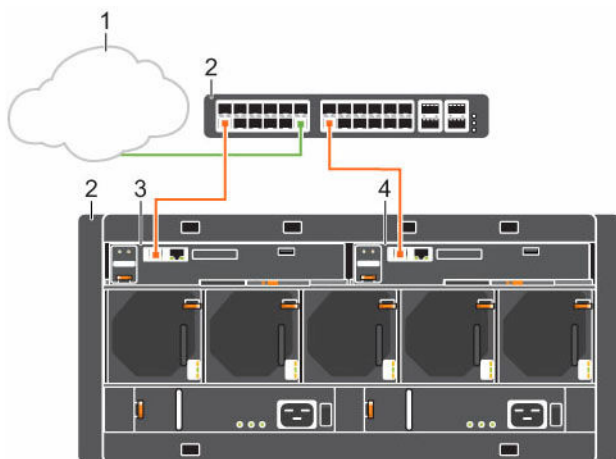

Figure 57. Storage System Connected to a Management Network

- | | |
|---------------------------------|-------------------------|
| 1. Corporate/management network | 2. Ethernet switch |
| 3. Storage system | 4. Storage controller 1 |
| 5. Storage controller 2 | |

NOTE: If the Flex Port license is installed, the management port becomes a shared iSCSI port. To use the management port as an iSCSI port, cable the management port to a network switch dedicated to iSCSI traffic. Special considerations must be taken into account when sharing the management port.

The Flex Port feature allows both Storage Center system management traffic and iSCSI traffic to use the same physical network ports. However, for environments where the Storage Center system management ports are mixed with network traffic from other devices, separate the iSCSI traffic from management traffic using VLANs.

Labeling the Ethernet Management Cables

Label the Ethernet management cables that connect each storage controller to an Ethernet switch.

Prerequisites

Locate the Ethernet management cable labels that shipped with the SCv2080 storage system.

About this task

Apply cable labels to both ends of each Ethernet management cable.

Steps

- Starting with the top edge of the label, attach the label to the cable near the connector.



Figure 58. Attach Label to Cable

- Wrap the label around the cable until it fully encircles the cable. The bottom of each label is clear so that it does not obscure the text.





Figure 59. Wrap Label Around Cable

3. Apply a matching label to the other end of the cable.

Cabling the Embedded Ports for iSCSI Replication

If the Storage Center is licensed for replication, the replication port can be connected to an Ethernet switch and used for iSCSI replication. If the Storage Center is licensed for replication and the Flex Port license is installed, the management port and replication port can both be connected to an Ethernet switch and used for iSCSI replication.

Cabling the Replication Port for iSCSI Replication

If replication is licensed, the replication (REPL) port can be used to replicate data to another Storage Center.

About this task

Connect the replication port of each storage controller to an Ethernet switch through which the Storage Center can perform iSCSI replication.

Steps

1. Connect the replication port on storage controller 1 to Ethernet switch 2.
2. Connect the replication port on storage controller 2 to Ethernet switch 2.

NOTE: The management port on each storage controller is connected to an Ethernet switch on the management network.

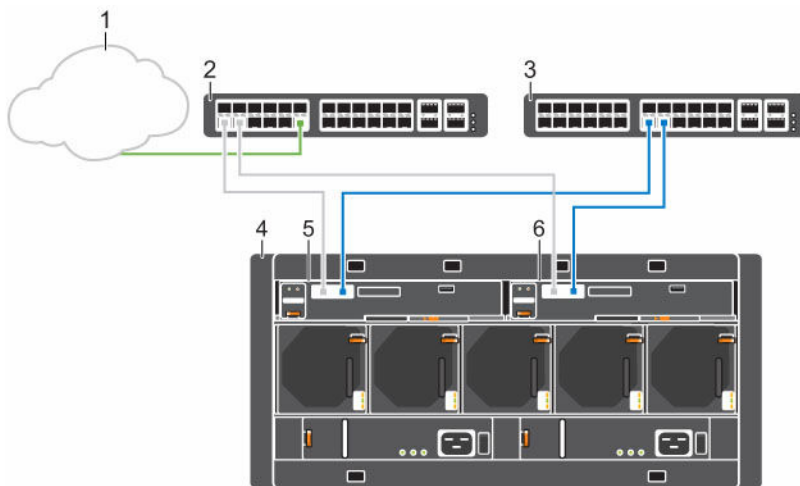

Figure 60. Replication Ports Connected to an iSCSI Network

1. Corporate/management network
2. Ethernet switch 1

- 3. Ethernet switch 2 (iSCSI network)
- 4. Storage system
- 5. Storage controller 1
- 6. Storage controller 2

3. To configure the fault domains and ports, click the **Configure Embedded iSCSI Ports** link on the **Configuration Complete** page of the **Discover and Configure Uninitialized SCv2000 Series Storage Centers** wizard.
4. To configure replication, refer to the *Dell Storage Manager Administrator's Guide*.

Related links

[Configure Embedded iSCSI Ports](#)

Cabling the Management Port and Replication Port for iSCSI Replication

If replication is licensed and the Flex Port license is installed, the management (MGMT) port and replication (REPL) port can be used to replicate data to another Storage Center.

About this task

Connect the management port and replication port on each storage controller to an Ethernet switch through which the Storage Center can perform replication.

NOTE:

The Flex Port feature allows both Storage Center system management traffic and iSCSI traffic to use the same physical network ports. However, for environments where the Storage Center system management ports are mixed with network traffic from other devices, separate the iSCSI traffic from management traffic using VLANs.

Steps

1. Connect Flex Port Domain 1 (shown in orange) to the iSCSI network.
 - a. Connect Ethernet switch 1 to the corporate/management network (shown in green).
 - b. Connect the management port on storage controller 1 to Ethernet switch 1.
 - c. Connect the management port on storage controller 2 to Ethernet switch 1.
2. Connect iSCSI Embedded Domain 2 (shown in blue) to the iSCSI network.
 - a. Connect the replication port on storage controller 1 to Ethernet switch 2.
 - b. Connect the replication port on storage controller 2 to Ethernet switch 2.

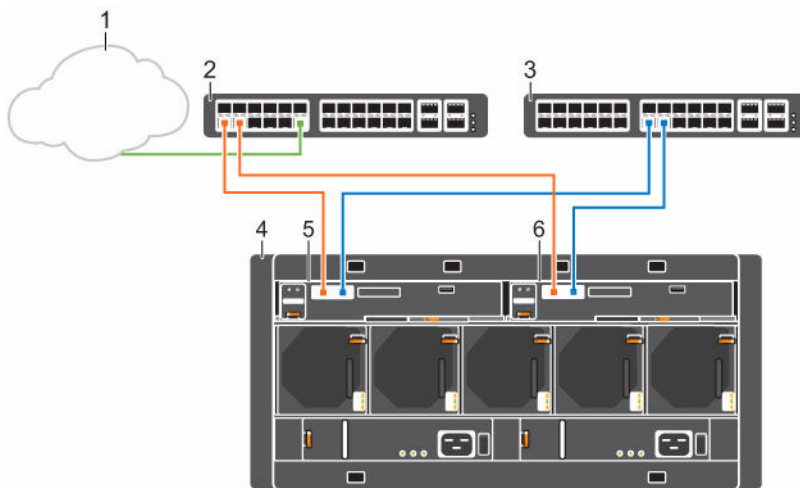

Figure 61. Management and Replication Ports Connected to an iSCSI Network

- 1. Corporate/management network
- 2. Ethernet switch 1 (iSCSI network)
- 3. Ethernet switch 2 (iSCSI network)
- 4. Storage system
- 5. Storage controller 1
- 6. Storage controller 2

3. To configure the fault domains and ports, click the **Configure Embedded iSCSI Ports** link on the **Configuration Complete** page of the **Discover and Configure Uninitialized SCv2000 Series Storage Centers** wizard.
4. To configure replication, see the *Dell Storage Manager Administrator's Guide*.



Related links

[Configure Embedded iSCSI Ports](#)

Cabling the Embedded Ports for iSCSI Host Connectivity

If the Flex Port license is installed on the Storage Center, the management port and replication port can be connected to an Ethernet switch and used for iSCSI host connectivity.

Dell recommends using two switches dedicated for iSCSI traffic. Refer to the iSCSI Settings appendix for a list of recommend and required settings.

Two iSCSI Networks using the Embedded Ethernet Ports on a Storage System with Dual Fibre Channel Storage Controllers

Use two iSCSI networks to prevent an unavailable port, switch, or storage controller from causing a loss of connectivity between the host servers and a storage system with dual Fibre Channel (FC) storage controllers.

About this task

This configuration includes two fault domains, two iSCSI networks, and two Ethernet switches.

- If a physical port or Ethernet switch becomes unavailable, the storage system is accessed from the switch in the other fault domain.
- If a storage controller becomes unavailable, the virtual ports on the offline storage controller move to the physical ports on the other storage controller.

 **NOTE: The Flex Port feature allows both Storage Center system management traffic and iSCSI traffic to use the same physical network ports. However, for environments where the Storage Center system management ports are mixed with network traffic from other devices (such as voice, backups, or other computing devices), separate iSCSI traffic from management traffic using VLANs.**

Steps

1. Connect each server and Ethernet switch 1 to the corporate/management network (shown in green).
2. Connect the servers that support iSCSI connections to both iSCSI networks.
3. Connect embedded fault domain 1 (shown in orange) to iSCSI network 1.
 - a. Connect the management port on storage controller 1 to Ethernet switch 1.
 - b. Connect the management port on storage controller 2 to Ethernet switch 1.
4. Connect embedded fault domain 2 (shown in blue) to iSCSI network 2.
 - a. Connect the replication port on storage controller 1 to Ethernet switch 2.
 - b. Connect the replication port on storage controller 2 to Ethernet switch 2.

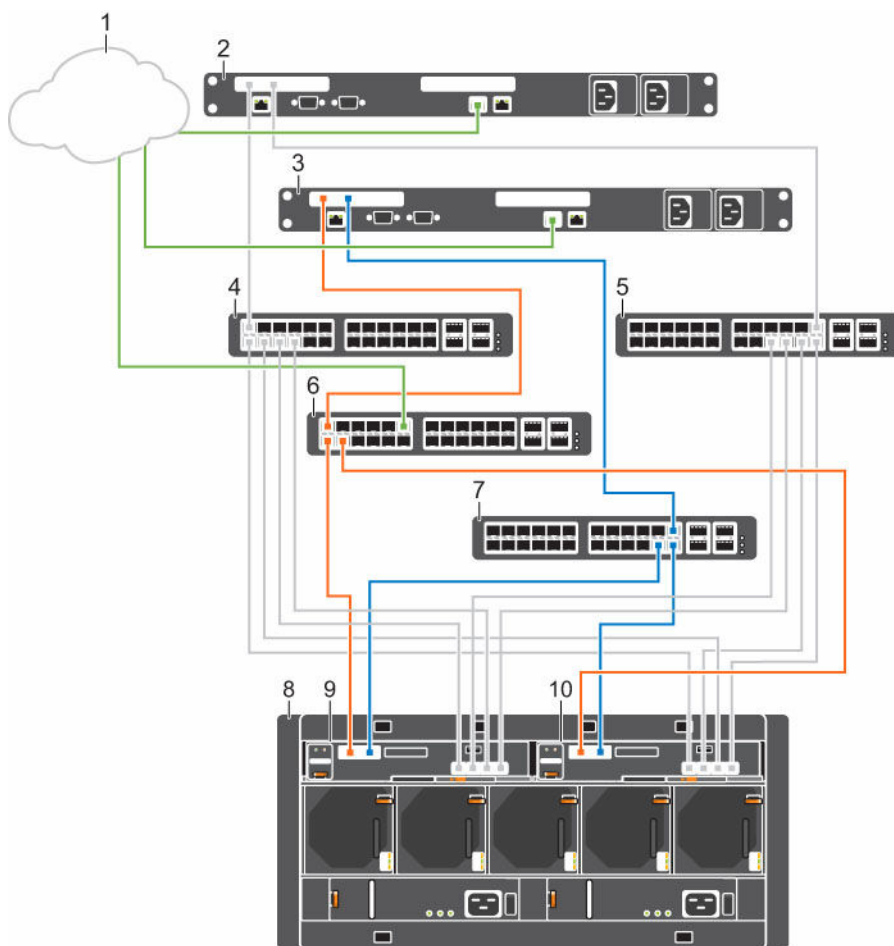

Figure 62. Two iSCSI Networks using the Embedded Ethernet Ports on Dual Fibre Channel Storage Controllers

- | | |
|---|---|
| 1. Corporate/management network | 2. Server 1 (FC) |
| 3. Server 2 (iSCSI) | 4. FC Switch 1 (fault domain 1 for FC fabric) |
| 5. FC Switch 2 (fault domain 2 for FC fabric) | 6. Ethernet switch 1 (fault domain 1) |
| 7. Ethernet switch 2 (fault domain 2) | 8. Storage system |
| 9. Storage controller 1 | 10. Storage controller 2 |

5. To configure the fault domains and ports, click the **Configure Embedded iSCSI Ports** link on the **Configuration Complete** page of the **Discover and Configure Uninitialized SCv2000 Series Storage Centers** wizard.

Next steps

Install or enable MPIO on the host servers.

NOTE: After the Storage Center configuration is complete, run the host access wizard to configure host server access and apply MPIO best practices. For the latest best practices, see the Dell Storage Center Best Practices document on the Dell TechCenter site (<http://en.community.dell.com/techcenter/storage/>).

Related links

[Configure Embedded iSCSI Ports](#)

Two iSCSI Networks Using the Embedded Ethernet Ports on a Storage System with Dual iSCSI Storage Controllers

Use two iSCSI networks to prevent an unavailable port, switch or storage controller from causing a loss of connectivity between the host servers and a storage system with dual iSCSI storage controllers.

About this task

This configuration includes two fault domains, two iSCSI networks, and two Ethernet switches.



- If a physical port or Ethernet switch becomes unavailable, the storage system is accessed from the switch in the other fault domain.
- If a storage controller becomes unavailable, the virtual ports on the offline storage controller move to the physical ports on the other storage controller.

NOTE: The Flex Port feature allows both Storage Center system management traffic and iSCSI traffic to use the same physical network ports. However, for environments where the Storage Center system management ports are mixed with network traffic from other devices (such as voice, backups, or other computing devices), separate iSCSI traffic from management traffic using VLANs.

Steps

1. Connect each server and Ethernet switch 1 to the corporate/management network (shown in green).
2. Connect each server to both iSCSI networks.
3. Connect embedded fault domain 1 (shown in orange) to iSCSI network 1.
 - a. Connect the management port on storage controller 1 to Ethernet switch 1.
 - b. Connect the management port on storage controller 2 to Ethernet switch 1
4. Connect embedded fault domain 2 (shown in blue) to iSCSI network 2.
 - a. Connect the replication port on storage controller 1 to Ethernet switch 2.
 - b. Connect the replication port on storage controller 2 to Ethernet switch 2.

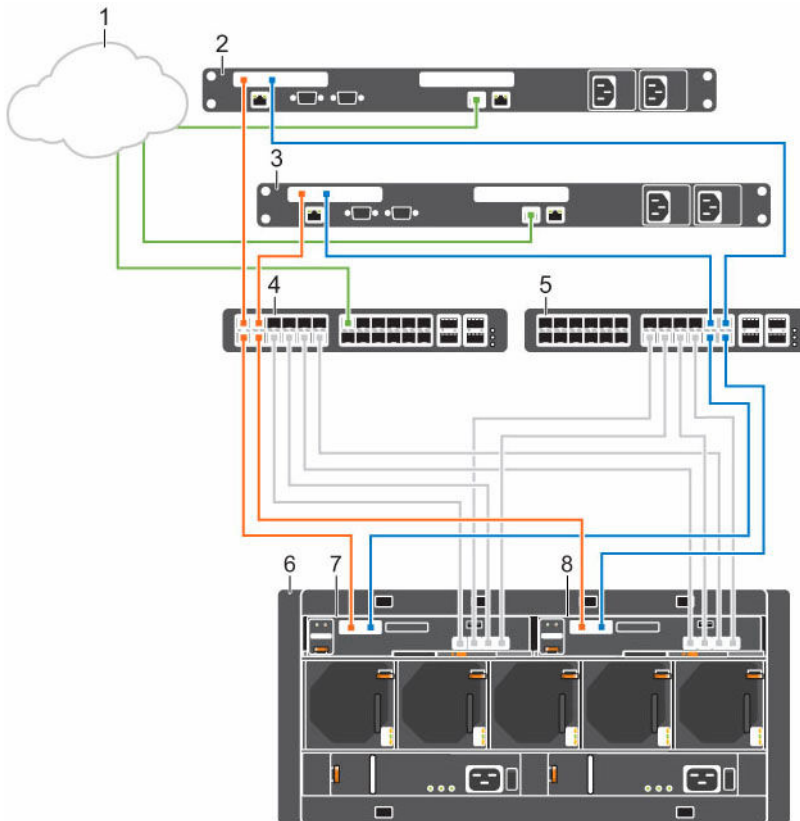

Figure 63. Two iSCSI Networks using the Embedded Ethernet Ports on Dual iSCSI Storage Controllers

- | | |
|---------------------------------------|---------------------------------------|
| 1. Corporate/management network | 2. Server 1 |
| 3. Server 2 | 4. Ethernet switch 1 (fault domain 1) |
| 5. Ethernet switch 2 (fault domain 2) | 6. Storage system |
| 7. Storage controller 1 | 8. Storage controller 2 |

5. To configure the fault domains and ports, click the **Configure Embedded iSCSI Ports** link on the **Configuration Complete** page of the **Discover and Configure Uninitialized SCv2000 Series Storage Centers** wizard.

Next steps

Install or enable MPIO on the host servers.



 **NOTE:** After the Storage Center configuration is complete, run the host access wizard to configure host server access and apply MPIO best practices. For the latest best practices, see the Dell Storage Center Best Practices document on the Dell TechCenter site (<http://en.community.dell.com/techcenter/storage/>).

Related links

[Configure Embedded iSCSI Ports](#)



Connect the Back-End Cabling and Connect the Power

Back-end cabling refers to the connections between the storage system and expansion enclosure. After the back-end cabling is complete, connect power cables to the storage system components and turn on the hardware.

An SCv2080 storage system can be deployed with or without an expansion enclosure.

- When an SCv2080 storage system is deployed without an expansion enclosure, the storage controllers must be interconnected using SAS cables. This connection enables SAS path redundancy between the storage controllers and the internal disks.
- When an SCv2080 storage system is deployed with an expansion enclosure, the expansion enclosure connects to the SAS ports on the storage controllers.

SC180 Expansion Enclosure Cabling Guidelines

You can connect a single SC180 expansion enclosure to an SCv2080 storage system.

The connection between a storage system and an expansion enclosure is referred to as a SAS chain. A SAS chain is made up of two paths, which are referred to as the A side and B side. Each side of the SAS chain starts at the initiator-only SAS port on one storage controller and ends at the initiator/target SAS port on the other storage controller.

Back-End SAS Redundancy

Use redundant SAS cabling to make sure that an unavailable I/O port or storage controller does not cause a Storage Center outage. If an I/O port or storage controller becomes unavailable, the Storage Center I/O continues on the redundant path.

Back-End SAS Port Types

Each storage controller has two types of back-end SAS ports: initiator only and initiator/target.

The ports labeled A are initiator-only ports and the ports labeled B are initiator/target ports.

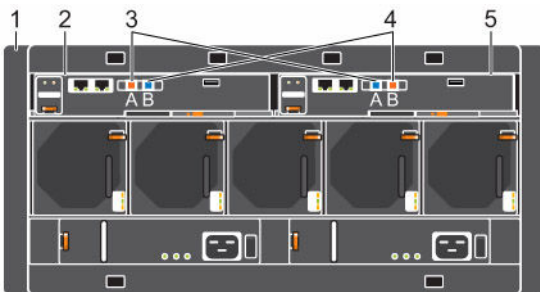

Figure 64. SCv2080 SAS Ports

- | | |
|-----------------------------------|-------------------------------------|
| 1. Storage system | 2. Storage controller 1 |
| 3. Initiator only ports (ports A) | 4. Initiator/target ports (ports B) |
| 5. Storage controller 2 | |

Back-End Connections for an SCv2080 Storage System Without an Expansion Enclosure

When you deploy an SCv2080 storage system without an expansion enclosure, you must interconnect the storage controllers using SAS cables.

NOTE: The left storage controller is storage controller 1 and the right storage controller is storage controller 2.

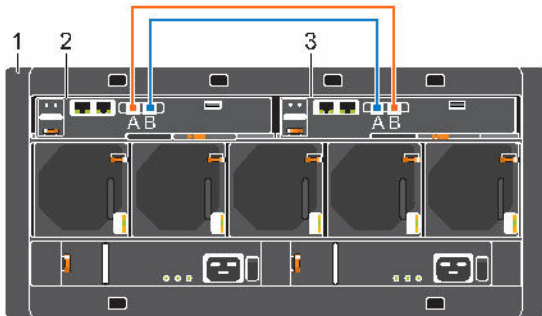

Figure 65. SCv2080 Without an Expansion Enclosure

- 1. SCv2080 storage system
- 2. Storage controller 1
- 3. Storage controller 2

The following table describes the back-end SAS connections for an SCv2080 storage system without an expansion enclosure.

Table 3. Storage System Without an Expansion Enclosure

Path	Connections
Chain 1: A Side (Orange)	Storage controller 1: port A to storage controller 2: port B.
Chain 1: B Side (Blue)	Storage controller 2: port A to the storage controller 1: port B.

Back-End Connections for an SCv2080 with an Expansion Enclosure

This figure shows how to connect the SCv2080 to an SC180 expansion enclosure.

The SCv2080 supports one SC180 expansion enclosure.



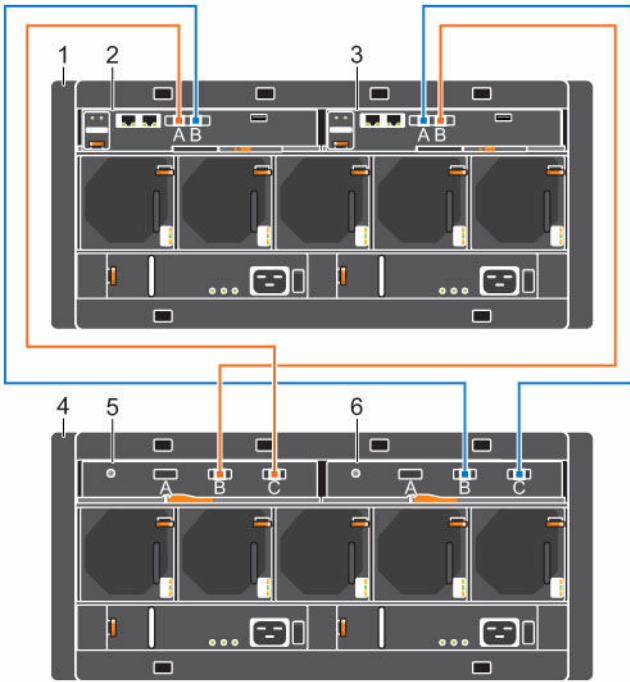

Figure 66. SCv2080 and One SC180 Expansion Enclosure

- | | |
|-------------------------|-------------------------|
| 1. Expansion enclosure | 2. Left EMM |
| 3. Right EMM | 4. Storage system |
| 5. Storage controller 1 | 6. Storage controller 2 |

Table 4. Storage System Connected to an Expansion Enclosure

Path	Connections
Chain 1: Side A (orange)	<ol style="list-style-type: none"> Storage controller 1: port A to expansion enclosure: left EMM, port C. Storage controller 2: port B to expansion enclosure: left EMM, port B.
Chain 1: Side B (blue)	<ol style="list-style-type: none"> Storage controller 2: port A to expansion enclosure: right EMM, port C. Storage controller 1: port B to expansion enclosure: right EMM, port B.

Label the Back-End Cables

Label the back-end cables that interconnect the storage controllers or label the back-end cables that connect the storage system to the expansion enclosures.

Prerequisites

Locate the cable labels provided with the expansion enclosures.

About this task

Apply cable labels to both ends of each SAS cable to indicate the chain number and side (A or B).

Steps

- Starting with the top edge of the label, attach the label to the cable near the connector.

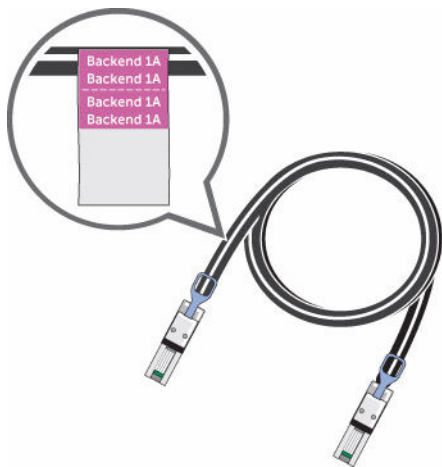

Figure 67. Attach Label to Cable

2. Wrap the label around the cable until it fully encircles the cable. The bottom of each label is clear so that it does not obscure the text.



Figure 68. Wrap Label Around Cable

3. Apply a matching label to the other end of the cable.

Connect Power Cables and Turn on the Storage System

Connect the power cables to the storage system components and turn on the hardware.

About this task

- If the storage system is installed without an expansion enclosure, connect power cables to the storage system chassis and turn on the storage system.
- If the storage system is installed with an expansion enclosure, connect power cables to the expansion enclosure chassis and turn on the expansion enclosure as described in the *Dell Storage Center SCv2080 Storage System Getting Started Guide*. After the expansion enclosure is powered on, connect power to the storage system chassis and turn on the storage system.

Steps

1. Ensure that the power switches are in the OFF position before connecting the power cables.
2. Connect the power cables to both PSUs in the storage system chassis and secure the power cables firmly to the brackets using the straps provided.



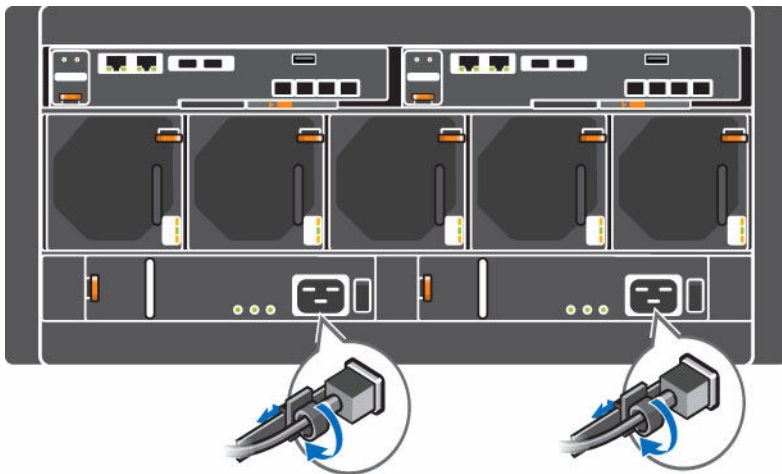

Figure 69. Connect the Power Cables

3. Plug the other end of the power cables into a grounded electrical outlet or a separate power source such as an uninterruptible power supply (UPS) or a power distribution unit (PDU).
4. Press both power switches on the rear of the storage system chassis to turn on the storage system.

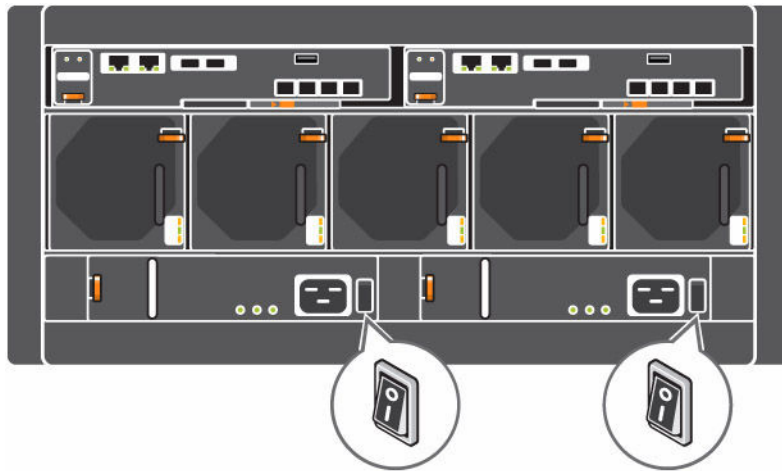

Figure 70. Turn on the Storage System

When the SCv2080 storage system is powered on, there is a delay while the storage system prepares to start up. During the first minute, the only indication that the storage system is powered on are the LEDs on the storage controllers. After the one-minute delay, the fans and LEDs turn on as an indication that the storage controllers are starting up.

5. Wait until the green diagnostic LEDs on the back of each storage controller match the pattern shown in [Figure 71. Storage Controller Diagnostic LEDs](#). This pattern indicates that a storage controller has started up successfully.

NOTE: It may take up to five minutes for a storage controller to completely start up.

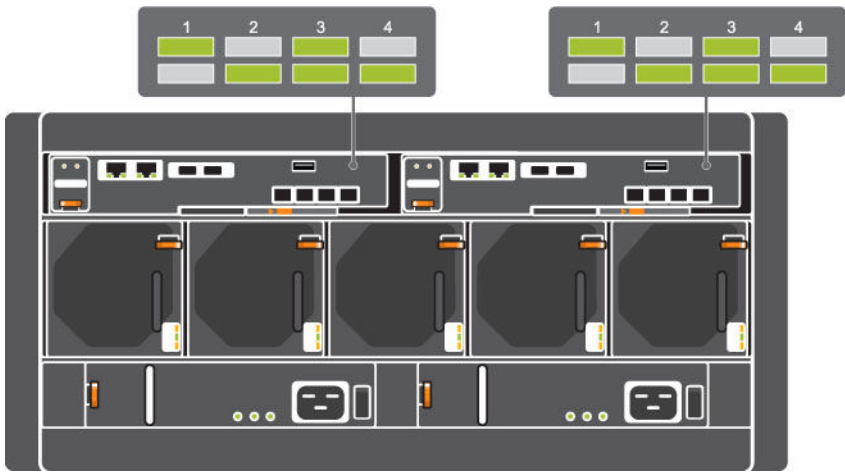

Figure 71. Storage Controller Diagnostic LEDs

Discover and Configure the Storage Center

The Discover and Configure Uninitialized SCv2000 Series Storage Centers wizard allows you to set up a Storage Center to make it ready for volume creation.

Use the Dell Storage Manager Client to discover and configure the Storage Center. After configuring a Storage Center, you can set up a localhost, VMware vSphere host, or VMware vCenter host using the host setup wizards.

The storage system hardware must be installed and cabled before the Storage Center can be configured.

Locating Your Service Tag

Your storage system is identified by a unique service tag and Express Service Code.

You can find the service tag on the back of the storage system chassis. Dell uses this information to route support calls to the appropriate personnel.

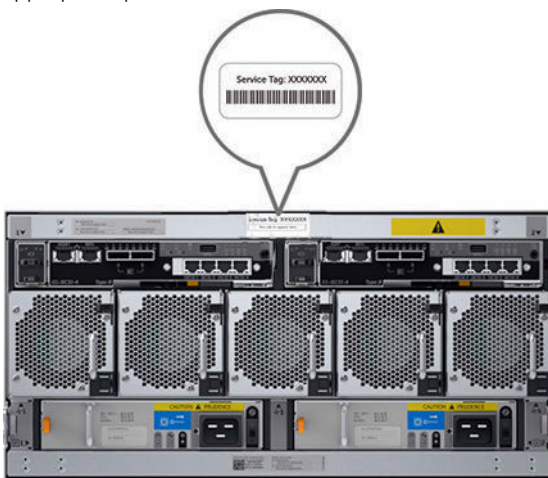

Figure 72. Service Tag Location

Worksheet to Record System Information

Use the following worksheet to record the information that is needed to install the SCv2080 storage system.

Storage Center Information

Gather and record the following information about the Storage Center network and the administrator user.

Table 5. Storage Center Network

Service Tag	_____
Management IPv4 address (Storage Center management address)	____ . ____ . ____ . ____
Left Controller IPv4 address (Controller 1 MGMT port)	____ . ____ . ____ . ____
Right Controller IPv4 address (Controller 2 MGMT port)	____ . ____ . ____ . ____

Subnet mask	-----
Gateway IPv4 address	-----
Domain name	-----
DNS server address	-----
Secondary DNS server address	-----

Table 6. Storage Center Administrator

Password for the default Storage Center “Admin” user	-----
Email address of the default Storage Center “Admin” user	-----

iSCSI Fault Domain Information

For a storage system with iSCSI front-end ports, gather and record network information for the iSCSI fault domains. This information is needed to complete the **Discover and Configure Uninitialized SCv2000 Series Storage Centers** wizard.

 **NOTE: For a storage system deployed with two Ethernet switches, Dell recommends setting up each fault domain on separate subnets.**

Table 7. iSCSI Fault Domain 1

Target IPv4 address	-----
Subnet mask	-----
Gateway IPv4 address	-----
IPv4 address for storage controller module 1: port 1	-----
IPv4 address for storage controller module 2: port 1	-----
(Four port I/O card only) IPv4 address for storage controller module 1: port 3	-----
(Four port I/O card only) IPv4 address for storage controller module 2: port 3	-----

Table 8. iSCSI Fault Domain 2

Target IPv4 address	-----
Subnet mask	-----
Gateway IPv4 address	-----
IPv4 address for storage controller module 1: port 2	-----
IPv4 address for storage controller module 2: port 2	-----
(4-port I/O card only) IPv4 address for storage controller module 1: port 4	-----
(4-port I/O card only) IPv4 address for storage controller module 2: port 4	-----

Additional Storage Center Information

The Network Time Protocol (NTP) and Simple Mail Transfer Protocol (SMTP) server information is optional. The proxy server information is also optional, but it may be required to complete the **Discover and Configure Uninitialized SCv2000 Series Storage Centers** wizard.



Table 9. NTP, SMTP, and Proxy Servers

NTP server IPv4 address	----- . ----- . ----- . -----
SMTP server IPv4 address	----- . ----- . ----- . -----
Backup SMTP server IPv4 address	----- . ----- . ----- . -----
SMTP server login ID	-----
SMTP server password	-----
Proxy server IPv4 address	----- . ----- . ----- . -----

Fibre Channel Zoning Information

For a storage system with Fibre Channel front-end ports, record the physical and virtual WWNs of the Fibre Channel ports in Fault Domain 1 and Fault Domain 2. This information is displayed on the **Review Front-End** page of the **Discover and Configure Uninitialized SCv2000 Series Storage Centers** wizard. Use this information to configure zoning on each Fibre Channel switch.

Table 10. Physical WWNs in Fault Domain 1

Physical WWN of storage controller 1: port 1	-----
Physical WWN of storage controller 2: port 1	-----
(4-port I/O card only) Physical WWN of storage controller 1: port 3	-----
(4-port I/O card only) Physical WWN of storage controller 2: port 3	-----

Table 11. Virtual WWNs in Fault Domain 1

Virtual WWN of storage controller 1: port 1	-----
Virtual WWN of storage controller 2: port 1	-----
(4-port I/O card only) Virtual WWN of storage controller 1: port 3	-----
(4-port I/O card only) Virtual WWN of storage controller 2: port 3	-----

Table 12. Physical WWNs in Fault Domain 2

Physical WWN of storage controller 1: port 2	-----
Physical WWN of storage controller 2: port 2	-----
(4-port I/O card only) Physical WWN of storage controller 1: port 4	-----
(4-port I/O card only) Physical WWN of storage controller 2: port 4	-----

Table 13. Virtual WWNs in Fault Domain 2

Virtual WWN of storage controller 1: port 2	-----
Virtual WWN of storage controller 2: port 2	-----
(4-port I/O card only) Virtual WWN of storage controller 1: port 4	-----
(4-port I/O card only) Virtual WWN of storage controller 2: port 4	-----

Supported Operating Systems for Storage Center Automated Setup

Setting up a Storage Center requires 64-bit versions of the following operating systems:

- Red Hat Enterprise Linux 6 or later



- SUSE Linux Enterprise 12 or later
- Windows Server 2008 R2 or later

Install and Use the Dell Storage Manager Client

You must start the Dell Storage Manager Client as an Administrator to run the Discover and Configure Uninitialized Storage Centers wizard.

1. Go to www.dell.com/support, navigate to the SCv2080 product support page, and download the Windows or Linux version of the Dell Storage Manager Client.
2. Install the Dell Storage Manager Client on the host server.
To discover and configure a Storage Center, the software must be installed on a host server that is on the same subnet as the storage system.
3. To start the software on a Windows computer, right-click on the Dell Storage Manager Client shortcut and select **Run as administrator**. To start the software on a Linux computer, execute the command `./Client` from the `var/lib/dell/bin` directory.
4. Click **Discover and Configure Uninitialized Storage Centers**. The **Discover and Configure Uninitialized Storage Centers** wizard appears.

Discover and Select an Uninitialized Storage Center

The first page of the Discover and Configure Uninitialized Storage Centers wizard provides a list of prerequisite actions and information required before setting up a Storage Center.

Prerequisites

- The host server, on which the Dell Storage Manager Client software is installed, must be on the same subnet or VLAN as the Storage Center.
- Temporarily disable any firewall on the host server that is running the Dell Storage Manager Client.
- Layer 2 multicast must be allowed on the network.
- Make sure that IGMP snooping is disabled on the switch ports connected to the Storage Center.

Steps

1. Make sure that you have the required information that is listed on the first page of the wizard. This information is needed to configure the Storage Center.
2. Click **Next**. The **Select a Storage Center to Initialize** page appears and lists the uninitialized Storage Centers discovered by the wizard.



NOTE: If the wizard does not discover the Storage Center that you want to initialize, perform one of the following actions:

- Make sure that the Storage Center hardware is physically attached to all necessary networks.
 - Make sure that the Storage Center is turned on for at least five minutes and does not display a fault LED.
 - Make sure that the diagnostic LEDs on the controllers are lit to indicate that the Storage Center is fully booted. See [Figure 71. Storage Controller Diagnostic LEDs](#).
 - Click **Rediscover**.
 - Click **Troubleshoot Storage Center Hardware Issue** to learn more about reasons why the Storage Center is not discoverable.
 - Click **Manually Discover Storage Center via MAC Address** to enter the MAC address for the Storage Center.
 - If the previous actions do not work, manually deploy the Storage Center. See [Deploy the Storage Center Using the Direct Connect Method](#).
3. Select the Storage Center to initialize.
 4. (Optional) Click **Enable Storage Center Indicator** to turn on the indicator light for the selected Storage Center. You can use the indicator to verify that you have selected the correct Storage Center.
 5. Click **Next**.



6. If the Storage Center is partially configured, the Storage Center login pane appears. Enter the management IPv4 address and the Admin password for the Storage Center, then click **Next** to continue.

Deploy the Storage Center Using the Direct Connect Method

Use the direct connect method to manually deploy the Storage Center when it is not discoverable.

1. Use an Ethernet cable to connect the computer running the Dell Storage Manager Client to the management port of the top controller.
2. Cable the bottom controller to the management network switch.
3. Click **Discover and Configure Uninitialized Storage Centers**. The **Discover and Configure Uninitialized Storage Centers** wizard opens.
4. Run the initial configuration wizard and complete all of the steps until the **Initialize Storage Center** page is displayed.
5. At this point, re-cable the management port of the top controller to the management network.
6. Connect the computer to the same subnet or VLAN as the Storage Center.
 - a. Click **Next**.
 - b. If the cable is not properly connected or the host cannot access the controller, an **OError setting up connection** message is displayed. Correct the connection and click **OK**.
 - c. If the deployment wizard is closed, click **Discover and Configure Uninitialized Storage Centers** to re-launch the deployment wizard.
 - d. Type the same credentials entered previously. and click **Next**.
7. Continue to setup the Storage Center following the procedures described after the [Initialize the Storage Center](#) procedure.

Set System Information

The **Set System Information** page allows you to enter Storage Center and storage controller configuration information to use when connecting to the Storage Center using Dell Storage Manager Client.

1. Type a descriptive name for the Storage Center in the **Storage Center Name** field.
2. Type the system management IPv4 address for the Storage Center in the **Virtual Management IPv4 Address** field.
The management IPv4 address is the IP address used to manage the Storage Center and is different from a storage controller IPv4 address.
3. Type an IPv4 address for the management port of each storage controller.
 **NOTE: The storage controller IPv4 addresses and management IPv4 address must be within the same subnet.**
4. Type the subnet mask of the management network in the **Subnet Mask** field.
5. Type the gateway address of the management network in the **Gateway IPv4 Address** field.
6. Type the domain name of the management network in the **Domain Name** field.
7. Type the DNS server addresses of the management network in the **DNS Server** and **Secondary DNS Server** fields.
8. Click **Next**.



Set Administrator Information

The Set Administrator Information page allows you to set a new password and an email address for the Admin user.

1. Enter a new password for the default Storage Center administrator user in the **New Admin Password** and **Confirm Password** fields.
2. Enter the email address of the default Storage Center administrator user in the **Admin Email Address** field.
3. Click **Next**.
 - For a Fibre Channel or SAS storage system, the **Confirm Configuration** page appears.
 - For an iSCSI storage system, the **Configure iSCSI Fault Domains** page appears.

Configure iSCSI Fault Domains

For a Storage Center with iSCSI front-end ports, use the Configure Fault Tolerance page and the Fault Domain pages to enter network information for the fault domains and ports.

1. (Optional) On the **Configure Fault Tolerance** page, click **More information about fault domains** or **How to set up an iSCSI network** to learn more about these topics.
2. Click **Next**.
 -  **NOTE: If any iSCSI ports are down, a dialog box appears that allows you to unconfigure these ports. Unconfiguring the down iSCSI ports will prevent unnecessary alerts.**
3. On the **Configure iSCSI HBA Fault Domain 1** page, enter network information for the fault domain and its ports.
 -  **NOTE: Make sure that all the IP addresses for iSCSI Fault Domain 1 are in the same subnet.**
4. Click **Next**.
5. On the **Configure iSCSI HBA Fault Domain 2** page, enter network information for the fault domain and its ports. Then click **Next**.
 -  **NOTE: Make sure that all the IP addresses for iSCSI Fault Domain 2 are in the same subnet.**
6. Click **Next**.

Confirm the Storage Center Configuration

Make sure that the configuration information shown on the Confirm Configuration page is correct before continuing.

1. Verify that the Storage Center settings are correct.
 - For an iSCSI storage system, verify that the iSCSI fault domain settings are correct.
 - To copy the configuration information to the clipboard so that it can be pasted into a document, click **Copy to clipboard**.
2. If the configuration information is correct, click **Apply Configuration**.
 - If the configuration information is incorrect, click **Back** and provide the correct information.
 -  **NOTE: After you click the Apply Configuration button, the configuration cannot be changed until after the Storage Center is fully configured.**

Initialize the Storage Center

The Storage Center sets up the system using the information provided on the previous pages.

1. The Storage Center performs system setup tasks. The **Initialize Storage Center** page displays the status of these tasks.
 - To learn more about the initialization process, click **More information about Initialization**.
 - If one or more of the system setup tasks fails, click **Troubleshoot Initialization Error** to learn how to resolve the issue.
 - If the Configuring Disks task fails, click **View Disks** to see the status of the disks detected by the Storage Center.
 - If any of the Storage Center front-end ports are down, the **Storage Center Front-End Ports Down** dialog box opens. Select the ports that are not connected to the storage network, then click **OK**.
2. When all of the Storage Center setup tasks are complete, click **Next**.



Review Fibre Channel Front-End Configuration

For a Storage Center with Fibre Channel front-end ports, the Fault Domains page displays an example of a fault domain topology based on the number of controllers and type of front-end ports. The Review Front-End Configuration page displays information about the fault domains created by the Storage Center.

1. (Optional) On the **Fault Tolerance** page, click **More information about fault domains** to learn more about fault domains.
2. Click **Next**.
3. On the **Review Redundant Paths** page, make sure that the information about the fault domains is correct.
4. Using the information provided on the **Review Redundant Paths** page, configure Fibre Channel zoning to create the physical and virtual zones described in [Fibre Channel Zoning](#).
5. Click **Next**.

 **NOTE: Virtual ports are created for all Fibre Channel front-end ports whether or not they will be used. Unused ports are displayed as being down.**

Review SAS Front-End Configuration

For a Storage Center with SAS front-end ports, the Fault Domains page displays an of a example fault domain topology based on the number of controllers and type of front-end ports. The Review Front-End Configuration page displays information about the fault domains created by the Storage Center.

1. (Optional) On the **Fault Domains** page, click **More information about fault domains** to learn more about fault domains.
2. Click **Next**.
3. On the **Review Front-End Configuration** page, make sure that the information about the fault domains is correct.
4. Click **Next**.

Configure Time Settings

Configure an NTP server to set the time automatically, or set the time and date manually.

1. From the **Region** and **Time Zone** drop-down menus, select the region and time zone used to set the time.
2. Select **Use NTP Server** and type the host name or IPv4 address of the NTP server, or select **Set Current Time** and set the time and date manually.
3. Click **Next**.

Configure SMTP Server Settings

If you have an SMTP server, configure the SMTP email settings to receive information from the Storage Center about errors, warnings, and events.

1. By default, the **Enable SMTP Email** checkbox is selected and enabled. If you do not have an SMTP server you can disable SMTP email by clearing the **Enable SMTP Email** checkbox.
2. Alternatively, if you have an SMTP server, configure the SMTP server settings.
 - a. In the **Recipient Email Address** field, enter the email address where the information will be sent.
 - b. In the **SMTP Mail Server** field, enter the IP address or fully qualified domain name of the SMTP mail server. Click **Test Server** to verify connectivity to the SMTP server.
 - c. (Optional) In the **Backup SMTP Mail Server** field, enter the IP address or fully qualified domain name of a backup SMTP mail server. Click **Test Server** to verify connectivity to the backup SMTP server.
 - d. If the SMTP server requires emails to contain a MAIL FROM address, specify an email address in the **Sender Email Address** field.
 - e. (Optional) In the **Common Subject Line** field, enter a subject line to use for all emails sent by the Storage Center.
 - f. Configure how the Storage Center identifies itself to the SMTP server:

- To use SMTP, type the Storage Center fully qualified domain name in the **Hello Message (HELO)** field.
 - To use ESMTP, select the **Send Extended Hello (EHLO)** check box, then type the Storage Center fully qualified domain name in the **Extended Hello Message (EHLO)** field.
- g. If the SMTP server requires clients to authenticate before sending email, select the **Use Authorized Login (AUTH LOGIN)** check box, then type a user name and password in the **Login ID** and **Password** fields.

3. Click **Next**.

Configure Key Management Server Settings

The Key Management Server Settings page opens if KMS is supported by the Storage Center license. Use this page to specify network settings and select the certificate files.

1. Specify network settings for the server.
2. Type the user name and password.
3. Select the SSL certificate files.
4. Click **Next**.

The **Configure Ports** page opens.

Review the SupportAssist System State Information Collection and Storage Agreement

The **SupportAssist System State Information Collection and Storage** page displays the text of the SupportAssist data agreement and allows you to accept or opt out of using SupportAssist.

1. To allow SupportAssist to collect diagnostic data and send this information to Dell Technical Support, select **By checking this box, you accept the above terms**.
2. Click **Next**.
3. If you did not select **By checking this box, you accept the above terms**, the **SupportAssist Recommended** pane opens.
 - Click **No** to return to the **SupportAssist Data Collection and Storage** page and accept the agreement.
 - Click **Yes** to opt out of using SupportAssist and proceed to the **Update Storage Center** page.

Advantages and Benefits of Dell SupportAssist

As an integral part of Dell's ability to provide best-of-class support for your Enterprise-class products, Dell SupportAssist proactively provides the information required to diagnose support issues, enabling the most efficient support possible and reducing the effort required by you.

A few key benefits of SupportAssist are:

- Enables proactive service requests and real-time troubleshooting
- Supports automatic case creation based on event alerting
- Enables ProSupport Plus and optimizes service delivery
- Provides automatic health checks
- Enables remote Storage Center updates

Dell strongly recommends enabling comprehensive support service at time of incident and proactive service with SupportAssist.

Provide Contact Information

Enter contact information for technical support to use when sending support-related communications from SupportAssist.

1. Specify the contact information.
2. To receive SupportAssist email messages, select **Yes, I would like to receive emails from SupportAssist when issues arise, including hardware failure notifications**.
3. Select the preferred contact method, language, and available times.



4. Type a shipping address where replacement Storage Center components can be sent.
5. Click **Next**.

Update Storage Center

The Storage Center attempts to contact the SupportAssist Update Server to check for updates. If you are not using SupportAssist, you must use the Storage Center Update Utility to update the Storage Center operating system before continuing.

- If no update is available, the **Storage Center Up to Date** page appears. Click **Next**.
- If an update is available, the current and available Storage Center versions are listed.
 - a. Click **Install** to update to the latest version.
 - b. If the update fails, click **Retry Update** to try to update again.
 - c. When the update is complete, click **Next**.
- If the SupportAssist Data Collection and Storage Agreement was not accepted, the Storage Center cannot check for updates.
 - To proceed without checking for an update, click **Next**.
 - To accept the agreement and check for an update:
 - a. Click **Accept SupportAssist Data Collection and Storage Agreement** to review the agreement.
 - b. Select **By checking this box you accept the above terms**.
 - c. Click **Next**. The Storage Center attempts to contact the SupportAssist Update Server to check for updates.
- The **Setup SupportAssist Proxy Settings** dialog box appears if the Storage Center cannot connect to the Dell SupportAssist Update Server. If the site does not have direct access to the Internet but uses a web proxy, configure the proxy settings:
 - a. Select **Enabled**.
 - b. Enter the proxy settings.
 - c. Click **OK**. The Storage Center attempts to contact the SupportAssist Update Server to check for updates.

Set Default Storage Profile

The storage profile determines the RAID types used when creating a volume.

About this task

The Set Default Storage Profile page is displayed in Dell Storage Manager 2016 R3 and later.

Steps

1. Select a profile from the **Default Storage Profile** drop-down menu.
 -  **NOTE: It is recommended to use the Maximize Efficiency storage profile if you plan to import data to this Storage Center.**
2. (Optional) To allow a different storage profile to be selected when creating a volume, place a check next to **Allow Storage Profile selection when creating a volume**.
3. Click **Next**.

Complete Configuration and Perform Next Steps

The Storage Center is now configured. The Configuration Complete page provides links to a Dell Storage Manager Client tutorial and wizards to perform the next setup tasks.

1. (Optional) Click one of the **Next Steps** to configure a localhost, configure a VMware host, or create a volume.
When you have completed the step, you are returned to the **Configuration Complete** page.
2. (Optional) Click one of the **Advanced Steps** to configure embedded iSCSI ports.
When you have completed the step, you are returned to the **Configuration Complete** page.
3. Click **Finish** to exit the wizard.

Set Up a localhost or VMware Host

After configuring a Storage Center, you can set up block-level storage for a localhost, VMware vSphere host, or VMware vCenter.

Set Up a localhost from Initial Setup

Configure a localhost to access block-level storage on the Storage Center. It is recommended that you perform this procedure for each host that is connected to the Storage Center.

Prerequisites

- Client must be running on a system with a 64-bit operating system.
- The Dell Storage Manager Client must be run by a Dell Storage Manager Client user with the Administrator privilege.
- On a Storage Center with Fibre Channel IO ports, configure Fibre Channel zoning before starting this procedure.

Steps

1. On the **Configuration Complete** page of the **Discover and Configure Storage Center** wizard, click **Set up block level storage for this host**.
The **Set up localhost for Storage Center** wizard appears.
 - If the Storage Center has iSCSI ports and the host is not connected to any interface, the **Log into Storage Center via iSCSI** page appears. Select the target fault domains, and then click **Log In**.
 - In all other cases, the **Verify localhost Information** page appears. Proceed to the next step.
2. On the **Verify localhost Information** page, verify that the information is correct. Then click **Create Server**.
The server definition is created on the Storage Center for the connected and partially connected initiators.
3. The **Host Setup Successful** page displays the best practices that were set by the wizard and best practices that were not set. Make a note of any best practices that were not set. It is recommended that these updates be applied manually before starting IO to the Storage Center.
4. (Optional) Select **Create a Volume for this host** to create a volume after finishing host setup.
5. Click **Finish**.

Set Up a VMware vSphere Host from Initial Setup

Configure a VMware vSphere host to access block-level storage on the Storage Center.

Prerequisites

- Client must be running on a system with a 64-bit operating system.
- The Dell Storage Manager Client must be run by a Dell Storage Manager Client user with the Administrator privilege.
- On a Storage Center with Fibre Channel IO ports, configure Fibre Channel zoning before starting this procedure.
- To download the correct SAS HBA driver for an ESXi host, go to www.vmware.com/resources/compatibility and search for Dell mpt3sas 04.00.00.00.1. Click the **Dell 12GB/s HBA external** link and download the **mpt3sas version 04.00.00.00.1vmw** driver.
- To update the SAS HBA driver on an ESXi host, see www.dell.com/Support/Article/us/en/19/HOW11081.
- Configure only one ESXi host at a time.
- To configure a host to access block-level storage on a Storage Center with SAS HBAs, you must connect to the Storage Center through a Dell Storage Manager Data Collector.

Steps

1. On the **Configuration Complete** page of the **Discover and Configure Storage Center** wizard, click **Configure VMware vSpheres to access a Storage Center**.
The **Set up VMware Host on Storage Center** wizard appears.
2. Enter the IP address or host name, the user name, and password. Then click **Next**.
 - If the Storage Center has iSCSI ports and the host is not connected to any interface, the **Log into Storage Center via iSCSI** page appears. Select the target fault domains, and then click **Log In**.
 - In all other cases, the **Verify vSpheres Information** page appears. Proceed to the next step.



3. Select an available port, and then click **Create Server**.
The server definition is created on the Storage Center.
4. The **Host Setup Successful** page displays the best practices that were set by the wizard and best practices that were not set. Make a note of any best practices that were not set by the wizard. It is recommended that these updates be applied manually before starting IO to the Storage Center.
5. (Optional) Select **Create a Volume for this host** to create a volume after finishing host setup.
6. Click **Finish**.

Set Up a VMware vCenter Host from Initial Setup

Configure a VMware vCenter cluster to access block-level storage on the Storage Center.

Prerequisites

- Client must be running on a system with a 64-bit operating system.
- The Dell Storage Manager Client must be run by a Dell Storage Manager Client user with the Administrator privilege.
- On a Storage Center with Fibre Channel IO ports, configure Fibre Channel zoning before starting this procedure.

About this task

 **NOTE: Block-level storage cannot be set up for a VMware vCenter on a Storage Center with SAS IO ports.**

Steps

1. On the **Configuration Complete** page of the **Discover and Configure Storage Center** wizard, click **Configure VMware vSpheres to access a Storage Center**.
The **Set up VMware Host on Storage Center** wizard appears.
2. Enter the IP address or host name, the user name, and password. Then click **Next**.
 - If the Storage Center has iSCSI ports and the host is not connected to any interface, the **Log into Storage Center via iSCSI** page appears. Select the hosts and target fault domains, and then click **Log In**.
 - In all other cases, the **Verify vCenters Information** page appears. Proceed to the next step.
3. Select an available port, and then click **Create Servers**.
The server definition is created on the Storage Center for each of the connected or partially connected hosts.
4. The **Host Setup Successful** page displays the best practices that were set by the wizard and best practices that were not set. Make a note of any best practices that were not set. It is recommended that these updates be applied manually before starting IO to the Storage Center.
5. Click **Finish**.

Create a Volume Using the Multiple-Step Wizard

The multiple-step wizard is the default method of creating volumes for SCv2000 series controllers.

1. Click **Create Volume**.
The **Create Volume** wizard opens.
2. In the **Volume Identification** page, specify the name, notes, and folder for the volume being created.
 - a. In the **Name** field, type the name for the volume.
 - b. (Optional) In the **Notes** field, type any notes associated with the volume.
 - c. In the **Volume Folder** pane, specify the location for the volume.
 - d. (Optional) To create a new volume folder, click **Create Folder**.
3. Click **Next**.
The **Specify Capacity** page is displayed.
4. In the **Size** field, type the desired size of the volume and select the unit of measurement from the drop-down menu.
5. Click **Next**.
The **Map to Server** page is displayed. To not specify a server, click **Next**.
6. To specify a server for the volume, click **Create Server**. For instructions on creating a server, see the *Dell Storage Manager Administrator's Guide*.

- a. Select the server.
- b. Click **Next**.

The **Volume Summary** page is displayed.

7. Click **Finish**.

Set the Default Storage Profile for New Volumes

The default Storage Profile is used when a new volume is created unless the user selects a different Storage Profile. You can prevent the Storage Profile from being changed during volume creation by clearing the **Allow Storage Profile Selection** checkbox.

1. Click the **Storage** view.
2. In the **Storage** pane, select a Storage Center.
3. In the **Summary** tab, click **Edit Settings**.
The **Edit Storage Center Settings** dialog box opens.
4. Click the **Preferences** tab.
5. From the **Storage Profile** drop-down menu, select the Storage Profile to use as the default for new volumes.
6. To allow users to select a Storage Profile when creating a volume, select the **Allow Storage Profile Selection** checkbox.
7. Click **OK**.

Configure Embedded iSCSI Ports

Configure the embedded Ethernet ports on the Storage Center for use as iSCSI ports.

1. If the Flex Port license is installed, configure the fault domain and ports for Flex Port Domain 1.

 **NOTE: The Flex Port feature allows both Storage Center system management traffic and iSCSI traffic to use the same physical network ports. However, for environments where the Storage Center system management ports are mixed with network traffic from other devices, separate the iSCSI traffic from management traffic using VLANs.**

- a. Enter the target IPv4 address, subnet mask, and gateway for the fault domain.
- b. Enter an IPv4 address for each port in the fault domain.

 **NOTE: Make sure that all the IP addresses for Flex Port Domain 1 are in the same subnet.**

2. Configure the fault domain and ports for iSCSI Embedded Domain 2.
 - a. Enter the target IPv4 address, subnet mask, and gateway for the fault domain.
 - b. Enter an IPv4 address for each port in the fault domain.

 **NOTE: Make sure that all the IP addresses for iSCSI Embedded Domain 2 are in the same subnet.**

3. Click **OK**.



Perform Post-Setup Tasks

Perform connectivity and failover tests to make sure that the Storage Center deployment was successful.

 **NOTE: Before testing failover, set the operation mode of the Storage Center to Maintenance. When you are finished testing failover, set the operation mode of the Storage Center back to Normal.**

Verify Connectivity and Failover

This section describes how to verify that the Storage Center is set up properly and performs failover correctly.

The process includes creating test volumes, copying data to verify connectivity, and shutting down a storage controller to verify failover and MPIO functionality.

Put the Storage Center Into Maintenance Mode

Performing some of the post-setup tasks will generate alerts that could lead to a support case being created. Use Dell Storage Manager Client to put the Storage Center into maintenance mode to suppress alerts during maintenance and testing activities.

1. In the **Summary** tab, click **Edit Settings**. The **Edit Storage Center Settings** dialog box opens.
2. In the **General** tab, select **Maintenance** from the **Operation Mode** drop-down menu.
3. Click **OK**.
The Storage Center is put into maintenance mode.

Create Test Volumes

Connect a server to the Storage Center, create one or more test volumes, and map them to the server to prepare for connectivity and failover testing.

1. Configure a localhost to access the Storage Center using the **Set up localhost on Storage Center** wizard.
2. Use the Dell Storage Manager Client to connect to the Storage Center.
3. Create a 25 GB test volume named TestVol1.
 - a. Click the **Storage** tab.
 - b. From the **Storage** tab navigation pane, click the **Volumes** node.
 - c. Click **Create Volume**. The **Create Volume** wizard opens.
 - d. Type TestVol1 in the **Name** field.
 - e. Set the volume size to 25 GB in the **Size** field.
 - f. Click **OK**
4. Select the volume and click **Map Volume to Server**. The **Map Volume to Server** dialog box opens.
 - a. Select the server to which to map the volume from the **Server** list.
 - b. Click **Next**.
 - c. Click **Advanced Options**.
 - d. Clear the **Allow the Storage Center to automatically determine the Controller to activate the Volume on** checkbox.
 - e. Select the left storage controller (storage controller 1), from the **Activate Volume on Controller** drop-down list.
 - f. Click **Finish**.
5. Repeat the previous steps to create a 25 GB volume named TestVol2 and configure it to be active on the right storage controller (storage controller 2).
6. Partition and format the test volumes on the server.

Test Basic Connectivity

Verify basic connectivity by copying data to the test volumes.

1. Connect to the server to which the volumes are mapped.
2. Create a folder on the TestVol1 volume, copy at least 2 GB of data to the folder, and verify that the data copied successfully.
3. Create a folder on the TestVol2 volume, copy at least 2 GB of data to the folder, and verify that the data copied successfully.

Test Storage Controller Failover

Test the Storage Center to make sure that a storage controller failover does not interrupt I/O.

About this task



CAUTION: When testing storage controller failover, do not restart a storage controller by pulling it out and reseating it. Instead, restart the storage controller using Dell Storage Manager Client.



NOTE: Before restarting a storage controller in this task, put the storage controller into maintenance mode. This mode suppresses alerts that may generate due to the storage controller restart.

Steps

1. Connect to a server, create a Test folder on the server, and copy at least 2 GB of data into it.
2. Restart the left storage controller while copying data to a test volume to verify that the storage controller failover event does not interrupt I/O.
 - a. Copy the Test folder to the TestVol1 volume.
 - b. During the copy process, restart the left storage controller (the storage controller through which TestVol1 is mapped) by selecting it from the **Hardware** tab and clicking **Shutdown/Restart Controller**.
 - c. Verify that the copy process continues while the storage controller restarts.
 - d. Wait several minutes and verify that the storage controller has finished restarting.
3. Restart the right storage controller while copying data to a test volume to verify that the storage controller failover event does not interrupt I/O.
 - a. Copy the Test folder to the TestVol2 volume.
 - b. During the copy process, restart the right storage controller (through which TestVol2 is mapped) by selecting it from the **Hardware** tab and clicking **Shutdown/Restart Controller**.
 - c. Verify that the copy process continues while the storage controller restarts.
 - d. Wait several minutes and verify that the storage controller has finished restarting.

Test MPIO

Perform the following tests for a Storage Center with Fibre Channel or iSCSI front-end connectivity if the network environment and servers are configured for MPIO. Always perform the following tests for a Storage Center with front-end SAS connectivity.

1. Create a Test folder on the server and copy at least 2 GB of data into it.
2. Make sure that the server is configured to use load balancing MPIO (round-robin).
3. Manually disconnect a path while copying data to TestVol1 to verify that MPIO is functioning correctly.
 - a. Copy the Test folder to the TestVol1 volume.
 - b. During the copy process, disconnect one of the I/O paths and verify that the copy process continues.
 - c. Reconnect the path.
4. Repeat the previous steps as necessary to test additional paths.
5. Restart the storage controller that contains the active path while I/O is being transferred and verify that the I/O process continues.
6. If the front-end connectivity of the Storage Center is Fibre Channel or iSCSI and the Storage Center is not in a production environment, restart the switch that contains the active path while I/O is being transferred, and verify that the I/O process continues.



Clean Up Test Volumes

After testing is complete, delete the volumes used for testing.

1. Connect to the server to which the volumes are mapped and remove the volumes.
2. Use the Dell Storage Manager Client to connect to the Storage Center.
3. Click the **Storage** tab.
4. From the **Storage** tab navigation pane, select the **Volumes** node.
5. Select the volumes to delete.
6. Right-click on the selected volumes and select **Delete**. The **Delete** dialog box opens.
7. Click **OK**.

Send Diagnostic Data Using Dell SupportAssist

Use Dell SupportAssist to send diagnostic data to Dell Technical Support.

1. Use the Dell Storage Manager Client to connect to the Storage Center.
2. In the **Summary** tab, click **Send SupportAssist Information Now**, which is located under **SupportAssist Actions** in the **Status** pane.
The **Send SupportAssist Information Now** dialog box opens.
3. Select **Storage Center Configuration** and **Detailed Logs**.
4. Click **OK**.
5. (Optional) If the Storage Center is in maintenance mode, return it to normal operation.



Adding or Removing an Expansion Enclosure

This section describes how to add an expansion enclosure to a storage system and how to remove an expansion enclosure from a storage system.

Adding an Expansion Enclosure to a Storage System

Use caution when adding an expansion enclosure to a live Storage Center system to preserve the integrity of the existing data.

Prerequisites

Install the expansion enclosure in a rack, but do not connect the expansion enclosure to the storage system. For more information, see the *Dell Storage Center SC180 Expansion Enclosure Getting Started Guide*.

Steps

1. Connect to the Storage Center using the Dell Storage Manager Client.
2. Check the disk count of the Storage Center system before adding the expansion enclosure.
3. Click the **Hardware** tab and select the **Enclosures** node in the Hardware tab navigation pane.
4. Click **Add Enclosure**. The **Add New Enclosure** wizard starts.
 - a. Click **Next** to validate the existing cabling.
 - b. If the drives are not installed, install the drives in the expansion enclosure.
 - c. Turn on the expansion enclosure. When the drives spin up, make sure that the front panel and power status LEDs show normal operation.
 - d. Click **Next**.
 - e. Connect the expansion enclosure to the A-side chain, then click **Next** to validate the A-side cabling.
 - f. Connect the expansion enclosure to the B-side chain, then click **Next** to validate the B-side cabling.
 - g. Click **Finish**.
5. To manually manage new unassigned disks:
 - a. Click the **Storage** tab.
 - b. In the **Storage** tab navigation pane, select the **Disks** node.
 - c. Click **Manage Unassigned Disks**. The **Manage Unassigned Disks** dialog box appears.
 - d. From the **Disk Folder** drop-down menu, select the disk folder for the unassigned disks.
 - e. Select **Perform RAID rebalance immediately**.
 - f. Click **OK**.

For more information, see the *Dell Storage Manager Administrator's Guide*.
6. Label the new back-end cables.

Related links

[Check the Disk Count before Adding an Expansion Enclosure](#)

[Add the Expansion Enclosure to the B-Side Chain](#)

[Label the Back-End Cables](#)

Check the Disk Count before Adding an Expansion Enclosure

Use the Dell Storage Manager Client to determine the number of drives that are currently accessible to the Storage Center.

1. Connect to the Storage Center using the Dell Storage Manager Client.
2. Select the **Storage** tab.
3. In the **Storage** tab navigation pane, select the **Disks** node.
4. On the **Disks** tab, record the number of drives that are accessible by the Storage Center.

Compare this value to the number of drives accessible by the Storage Center after adding an expansion enclosure to the storage system.



Add the Expansion Enclosure to the A-Side Chain

Connect the expansion enclosure to one chain at a time to maintain drive availability.

1. Disconnect the A-side chain that interconnects the storage controllers.
Remove the SAS cable that connects storage controller 1: port A to storage controller 2: port B.

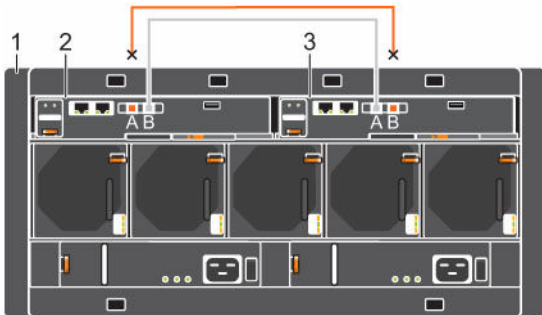

Figure 73. Remove the A-Side Cable from the Storage Controllers

1. Storage system
 2. Storage controller 1
 3. Storage controller 2
2. Add the expansion enclosure to the A-side chain.
 - a. Connect a SAS cable from storage controller 1: port A to the expansion enclosure: left EMM, port C.
 - b. Connect a SAS cable from storage controller 2: port B to the expansion enclosure: left EMM, port B.

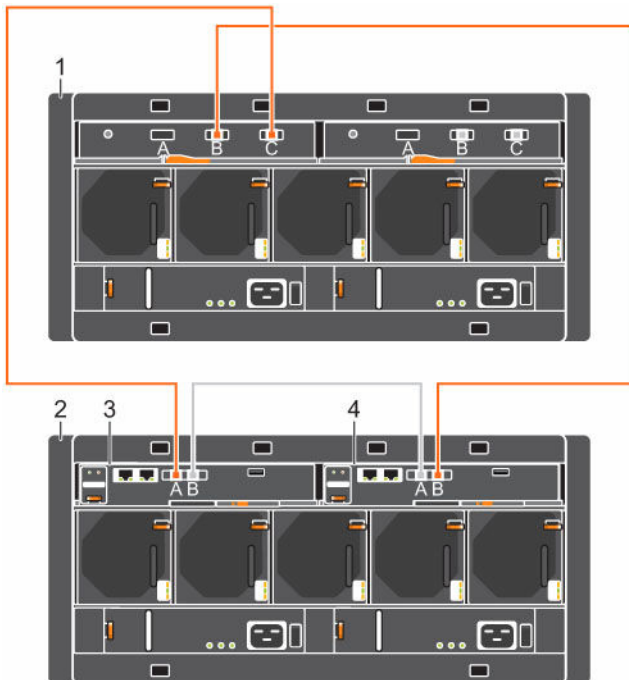

Figure 74. Connect the A-Side Cables to the Expansion Enclosure

1. Expansion enclosure
2. Storage system
3. Storage controller 1
4. Storage controller 2

Add the Expansion Enclosure to the B-Side Chain

Connect the expansion enclosure to one chain at a time to maintain drive availability.

1. Disconnect the B-side chain that interconnects the storage controllers.
Remove the SAS cable that connects storage controller 1: port B to storage controller 2: port A.

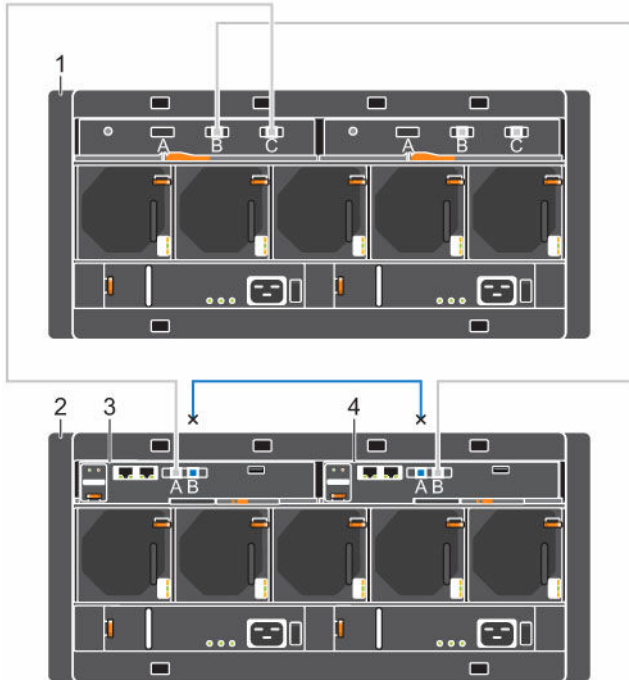

Figure 75. Remove the B-Side Cable from the Storage Controllers

1. Expansion enclosure
 2. Storage system
 3. Storage controller 1
 4. Storage controller 2
2. Add the expansion enclosure to the B-side chain.
 - a. Connect a SAS cable from storage controller 1: port B to the expansion enclosure: right EMM, port B.
 - a. Connect a SAS cable from storage controller 2: port A to the expansion enclosure: right EMM, port C.

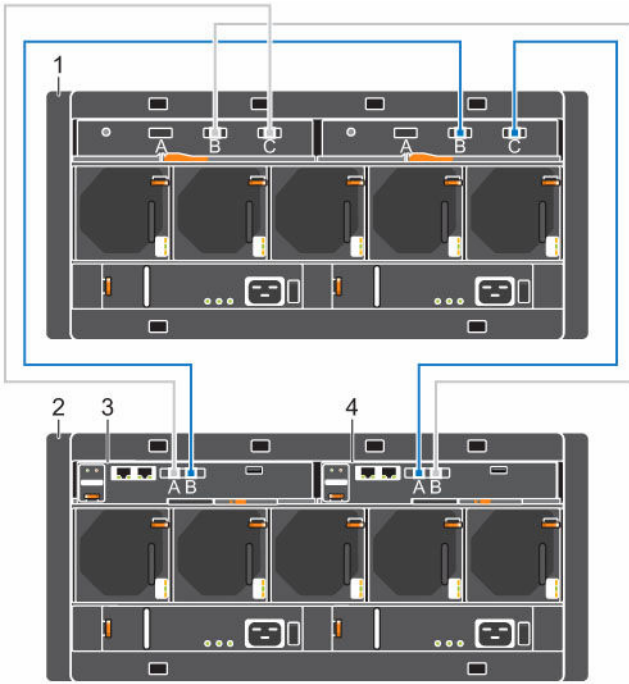

Figure 76. Connect the B-Side Cables to the Expansion Enclosure

- | | |
|-------------------------|-------------------------|
| 1. Expansion enclosure | 2. Storage system |
| 3. Storage controller 1 | 4. Storage controller 2 |

Label the Back-End Cables

Label the back-end cables that interconnect the storage controllers or label the back-end cables that connect the storage system to the expansion enclosures.

Prerequisites

Locate the cable labels provided with the expansion enclosures.

About this task

Apply cable labels to both ends of each SAS cable to indicate the chain number and side (A or B).

Steps

1. Starting with the top edge of the label, attach the label to the cable near the connector.

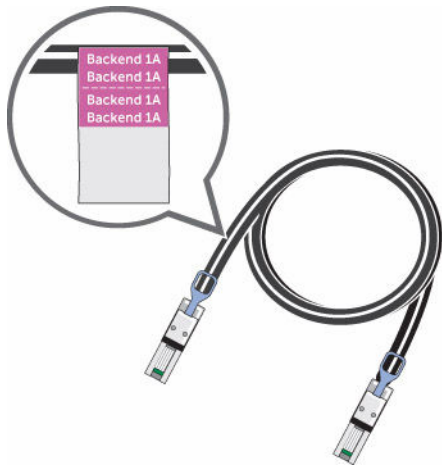

Figure 77. Attach Label to Cable

2. Wrap the label around the cable until it fully encircles the cable. The bottom of each label is clear so that it does not obscure the text.



Figure 78. Wrap Label Around Cable

3. Apply a matching label to the other end of the cable.

Removing an Expansion Enclosure from a Chain Currently in Service

To remove an expansion enclosure, you disconnect the expansion enclosure from one side of the chain at a time.

About this task

During this process, one side of the chain is disconnected. The Storage Center directs all I/O to the other side of the chain, which remains connected.

CAUTION: Make sure that your data is backed up before removing an expansion enclosure.

Before physically removing an expansion enclosure, make sure that none of the drives in the enclosure are managed by the Storage Center Operating System.

Steps

1. Connect to the Storage Center using the Dell Storage Manager Client.
2. Use the Dell Storage Manager Client to release the disks in the expansion enclosure.
3. Select the expansion enclosure to remove and click **Remove Enclosure**. The **Remove Enclosure** wizard starts.
4. Confirm the details of your current installation and click **Next** to validate the cabling.



5. Locate the expansion enclosure in the rack. Click **Next**.
6. Disconnect the A-side chain.
 - a. Disconnect the A-side cables that connect the expansion enclosure to the storage system. Click **Next**.
 - b. Reconnect the A-side cables to exclude the expansion enclosure from the chain. Click **Next** to validate the cabling.
7. Disconnect the B-side chain.
 - a. Disconnect the B-side cables that connect the expansion enclosure to the storage system. Click **Next**.
 - b. Reconnect the B-side cables to exclude the expansion enclosure from the chain. Click **Next** to validate the cabling.
8. Click **Finish**.

Related links

- [Release the Disks in the Expansion Enclosure](#)
- [Disconnect the A-Side Chain from the SC180 Expansion Enclosure](#)
- [Disconnect the B-Side Chain from the SC180 Expansion Enclosure](#)

Release the Disks in the Expansion Enclosure

Use the Dell Storage Manager Client to release the disks in an expansion enclosure before removing the expansion enclosure.

About this task

Releasing disks causes all of the data to move off the disks.

 **NOTE: Do not release disks unless the remaining disks have enough free space for the restriped data.**

Steps

1. Use the Dell Storage Manager Client to connect to the Storage Center.
2. Click the **Hardware** tab.
3. In the **Hardware** tab navigation pane, expand the enclosure to remove.
4. Select the **Disks** node.
5. Expand the **Drawer 1** and **Drawer 2** folders to view the disks.
6. Select all of the disks in the expansion enclosure.
7. Right-click on the selected disks and select **Release Disk**. The **Release Disk** dialog box opens.
8. Select **Perform RAID rebalance immediately**.
9. Click **OK**.

When all of the drives in the expansion enclosure are in the **Unassigned** disk folder, the expansion enclosure is safe to remove.

Disconnect the A-Side Chain from the SC180 Expansion Enclosure

Disconnect the A-side chain from the expansion enclosure.

About this task

 **CAUTION: To disconnect the A-side chain without a system outage, disconnect the A-side cable from storage controller 1 first. Disconnecting a different cable in the chain may disrupt IO to the expansion enclosure, resulting in a system outage.**

Steps

1. Remove the SAS cable between storage controller 1: port A and the expansion enclosure: left EMM, port C.
2. In the Dell Storage Manager Client, verify that port A on storage controller 1 and port A on storage controller 2 are **Up**. The B-side chain continues to carry IO while the A-side chain is disconnected.
3. Remove the SAS cable between storage controller 2: port B and the expansion enclosure: left EMM, port B.

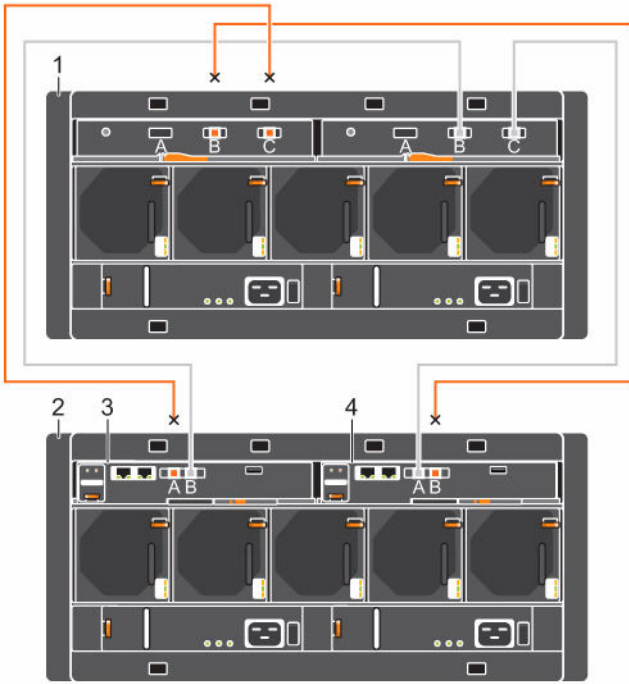

Figure 79. Disconnecting the SC180 Expansion Enclosure from the A-side Chain

1. Expansion enclosure
 2. Storage system
 3. Storage controller 1
 4. Storage controller 2
4. Connect a SAS cable between storage controller 1: port A and storage controller 2: port B.

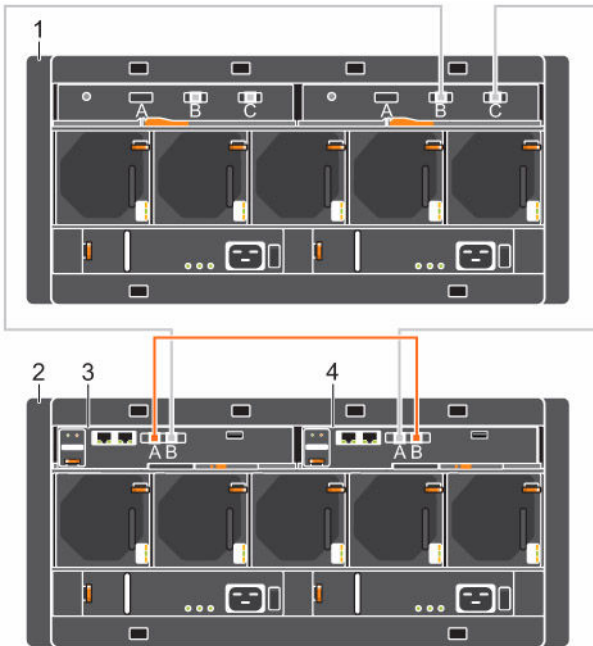

Figure 80. Reconnecting the A-side Chain

1. Expansion enclosure
2. Storage system
3. Storage controller 1
4. Storage controller 2

Disconnect the B-Side Chain from the SC180 Expansion Enclosure

Disconnect the B-side chain from the expansion enclosure.

1. Remove the SAS cable between storage controller 2: port A and the expansion enclosure: right EMM, port B.
2. In the Dell Storage Manager Client, verify that port A on storage controller 1 and port B on storage controller 2 are **Up**. The A-side chain continues to carry IO while the B-side chain is disconnected.
3. Remove the SAS cable between storage controller 1: port B and the expansion enclosure: right EMM, port C.

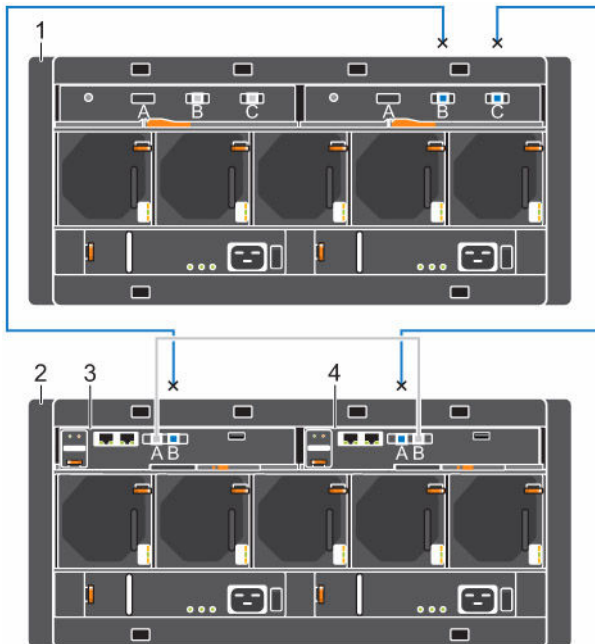

Figure 81. Disconnecting the SC180 Expansion Enclosure from the B-side Chain

1. Expansion enclosure
 2. Storage system
 3. Storage controller 1
 4. Storage controller 2
4. Connect a SAS cable between storage controller 1: port B and storage controller 2: port A. The expansion enclosure is now disconnected and can be removed.

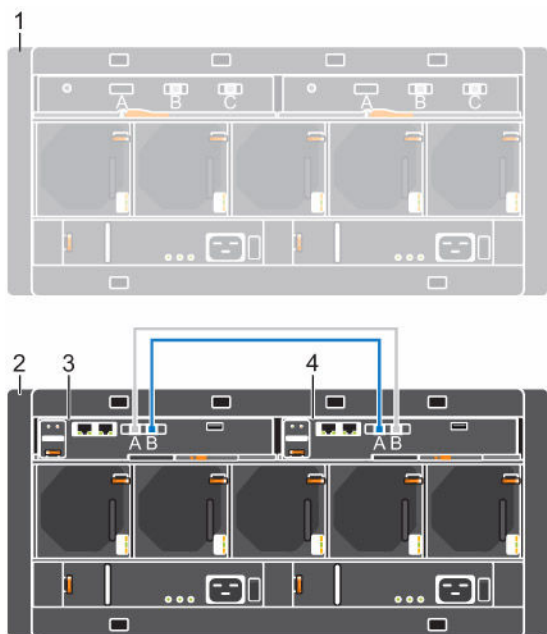

Figure 82. Expansion Enclosure Disconnected

1. Disconnected expansion enclosure
2. Storage system
3. Storage controller 1
4. Storage controller 2

Troubleshooting Storage Center Deployment

This section contains troubleshooting steps for common Storage Center deployment issues.

Troubleshooting Storage Controllers

To troubleshoot storage controllers:

1. Check the status of the storage controller using the Dell Storage Manager Client.
2. Check the position of the storage controllers. The lower HSN should be on the left, and the higher HSN should be on the right.
3. Check the pins and reseal the storage controller.
 - a. Remove the storage controller.
 - b. Verify that the pins on the storage system backplane and the storage controller are not bent.
 - c. Reinstall the storage controller.
4. Determine the status of the storage controller link status indicators. If the indicators are not green, check the cables.
 - a. Shut down the storage controller.
 - b. Reseat the cables on the storage controller.
 - c. Restart the storage controller.
 - d. Recheck the link status indicators. If the link status indicators are not green, replace the cables.

Troubleshooting Hard Drives

To troubleshoot hard drives:

1. Check the status of the hard drive using the Dell Storage Manager Client.
2. Determine the status of the hard drive indicators.
 - If the hard drive status indicator blinks amber on 2 seconds / off 1 second, the hard drive has failed.
 - If the hard drive status indicator is not lit, proceed to the next step.
3. Check the connectors and reseal the hard drive.

 **CAUTION: Perform this step only on unmanaged drives or after you confirm that the particular drive contains no user data. The Fault LED alone is not an indication that you can safely remove the drive.**

- a. Remove the hard drive.
- b. Check the hard drive and the backplane to ensure that the connectors are not damaged.
- c. Reinstall the hard drive. Make sure the hard drive makes contact with the backplane.

Troubleshooting Expansion Enclosures

To troubleshoot expansion enclosures:

1. Check the status of the expansion enclosure using the Dell Storage Manager Client.
2. If an expansion enclosure and/or drives are missing from the Dell Storage Manager Client, you might need to check for and install Storage Center updates to use the expansion enclosure and/or drives.
3. If an expansion enclosure firmware update fails, check the back-end cabling and ensure that redundant connections are used.