

Dell Storage NX3330 Owner's Manual

Notes, cautions, and warnings

 **NOTE:** A NOTE indicates important information that helps you make better use of your product.

 **CAUTION:** A CAUTION indicates either potential damage to hardware or loss of data and tells you how to avoid the problem.

 **WARNING:** A WARNING indicates a potential for property damage, personal injury, or death.

Chapter 1: About your system	7
Front-panel features and indicators.....	7
LCD panel.....	8
Back panel features and indicators.....	10
Diagnostic indicators.....	11
Hard drive indicator codes.....	13
iDRAC Direct LED indicator codes.....	13
NIC indicator codes.....	14
Power supply unit indicator codes.....	14
Locating your system Service Tag.....	16
Chapter 2: Documentation resources	17
Chapter 3: Technical specifications	19
Chapter 4: Initial system setup and configuration	23
Setting up your system.....	23
iDRAC configuration.....	23
Options to set up iDRAC IP address.....	23
Log in to iDRAC.....	24
Options to install the operating system.....	24
Methods to download firmware and drivers.....	24
Manage your system.....	25
Chapter 5: Pre-operating system management applications	26
Options to manage the pre-operating system applications.....	26
System Setup.....	26
Viewing System Setup.....	26
System Setup details.....	27
System BIOS.....	27
iDRAC Settings utility.....	46
Device Settings.....	46
Dell Lifecycle Controller.....	46
Embedded systems management.....	46
Boot Manager.....	47
Viewing Boot Manager.....	47
Boot Manager main menu.....	47
PXE boot.....	47
Chapter 6: Installing and removing system components	48
Safety instructions.....	48
Before working inside your system.....	49
After working inside your system.....	49
Recommended tools.....	49

Front bezel (optional).....	50
Removing the optional front bezel.....	50
Installing front bezel.....	50
Removing system cover.....	51
Installing the system cover.....	51
Inside system.....	52
Cooling shroud.....	54
Removing the cooling shroud.....	54
Installing the cooling shroud.....	54
System memory.....	55
General memory module installation guidelines.....	57
Mode-specific guidelines.....	57
Sample memory configurations.....	58
Removing memory modules.....	60
Installing memory modules.....	61
Hard disk drives.....	63
Removing 2.5 inch HDD blank.....	63
Installing 2.5 inch HDD blank.....	64
Removing hot-swappable HDD.....	64
Installing hot-swappable HDD.....	65
Removing HDD from HDD carrier.....	66
Installing HDD into HDD carrier.....	67
Optical drive (optional).....	67
Removing optical drive.....	67
Installing the optical drive.....	68
Removing the slim optical drive blank.....	69
Installing the slim optical drive blank.....	70
Cooling fans.....	71
Removing cooling fan.....	71
Installing cooling fan.....	72
Expansion cards and expansion card riser.....	73
Expansion card installation guidelines.....	73
Removing expansion card.....	74
Installing expansion card.....	75
Removing expansion-card risers.....	75
Installing expansion card risers.....	77
SD vFlash card (optional).....	77
Removing the optional SD vFlash card.....	77
Integrated storage controller card.....	78
Removing integrated storage controller card.....	78
Installing integrated storage controller card.....	79
Network daughter card.....	80
Removing NDC.....	80
Installing the network daughter card.....	81
Processors and heat sinks.....	82
Removing a processor.....	83
Installing a processor.....	85
PSUs.....	88
Hot spare feature.....	88
Removing the power supply unit blank.....	88

Installing the power supply unit blank.....	89
Removing an AC power supply unit.....	90
Installing an AC power supply unit.....	91
System battery.....	92
Replacing the system battery.....	92
Hard disk drive backplane.....	93
Removing HDD backplane.....	94
Installing HDD backplane.....	95
Control panel.....	96
Removing control panel board–8 HDD system.....	96
Installing the control panel board–eight hard drive system.....	97
Removing control panel–8 HDD system.....	98
Installing control panel–8 HDD system.....	99
VGA module.....	100
Removing the VGA module.....	100
Installing the VGA module.....	101
System board.....	102
Removing system board.....	102
Installing system board.....	104
Restoring the Service Tag by using the Easy Restore feature.....	106
Trusted Platform Module.....	106
Installing the Trusted Platform Module.....	106
Initializing the TPM for BitLocker users.....	107
Initializing the TPM for TXT users.....	108
Chapter 7: Using system diagnostics.....	109
Dell Embedded System Diagnostics.....	109
When to use the Embedded System Diagnostics.....	109
Running the Embedded System Diagnostics from Boot Manager.....	109
Running the Embedded System Diagnostics from the Dell Lifecycle Controller.....	109
System diagnostic controls.....	110
Chapter 8: Jumpers and connectors	111
System board jumper settings.....	111
System board connectors.....	112
Disabling forgotten password.....	114
Chapter 9: Troubleshooting your system.....	115
Troubleshooting system startup failure.....	115
Troubleshooting external connections.....	115
Troubleshooting the video subsystem.....	116
Troubleshooting a USB device.....	116
Troubleshooting iDRAC Direct (USB XML configuration).....	117
Troubleshooting iDRAC Direct (Laptop connection).....	117
Troubleshooting a serial I/O device.....	118
Troubleshooting a NIC.....	118
Troubleshooting a wet system.....	119
Troubleshooting a damaged system.....	119
Troubleshooting the system battery.....	120

Troubleshooting power supply units.....	121
Troubleshooting power source problems.....	121
Power supply unit problems.....	121
Troubleshooting cooling problems.....	122
Troubleshooting cooling fans.....	122
Troubleshooting system memory.....	123
Troubleshooting an internal USB key.....	124
Troubleshooting an optical drive.....	124
Troubleshooting a tape backup unit.....	125
Troubleshooting a hard drive or SSD.....	125
Troubleshooting a storage controller.....	126
Troubleshooting expansion cards.....	127
Troubleshooting processors.....	127
System messages.....	128
Warning messages.....	128
Diagnostic messages.....	128
Alert messages.....	128
Chapter 10: Getting help.....	129
Contacting Dell.....	129
Documentation feedback.....	129
Quick Resource Locator	129

About your system

The Dell Storage NX3330 is a rack system that supports up to two processors based on the Intel Haswell E5-2600 v3 processor family, up to 24 DIMMs, and storage capacity up to eight internal, hot-swappable 2.5-inch hard disk drives (HDDs).

Topics:

- [Front-panel features and indicators](#)
- [Back panel features and indicators](#)
- [Diagnostic indicators](#)
- [Hard drive indicator codes](#)
- [iDRAC Direct LED indicator codes](#)
- [NIC indicator codes](#)
- [Power supply unit indicator codes](#)
- [Locating your system Service Tag](#)

Front-panel features and indicators

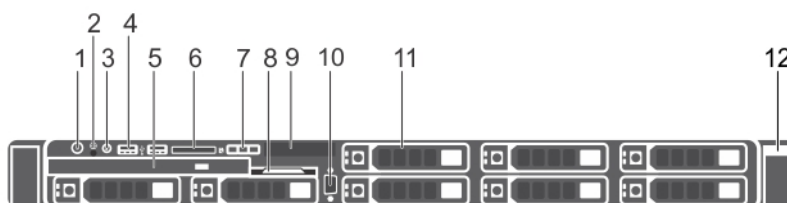





Figure 1. Front-panel features and indicators—8 HDD system

Table 1. Front-panel features and indicators

Item	Indicator, Button, or Connector	Icon	Description
1	Turn on indicator, power button		The turn on indicator glows when the system is turn on. The power button controls the power supply unit (PSU) output to the system. NOTE: On ACPI-compliant operating systems (OSs), turning off the system using the power button causes the system to perform a graceful shutdown before power to the system is turned off.
2	NMI button		Used to troubleshoot software and device driver errors when running certain OSs. This button can be pressed using the end of a paper clip. Use this button only if directed to do so by qualified support personnel or by the OS documentation.
3	System identification button		The identification buttons on the front- and back panels can be used to locate a particular system within a rack. When one of these buttons is pressed, the LCD panel on the front and the system status indicator on the back flashes blue until one of the buttons is pressed again.

Table 1. Front-panel features and indicators (continued)

Item	Indicator, Button, or Connector	Icon	Description
			Press to toggle the system ID to ON or OFF. If the system stops responding during POST, press and hold the system ID button for more than five seconds to enter BIOS progress mode.
			To reset the iDRAC (if not disabled on the iDRAC Setup page by pressing F2) press and hold the button for more than 15 seconds.
4	USB management port/iDRAC Direct (2)		Allows you to connect USB drives to the system or provides access to the iDRAC Direct features. For more information, see the <i>Integrated Dell Remote Access Controller User's Guide</i> at dell.com/esmmanuals . The ports are USB 2.0-compliant.
5	Optical drive		One optional SATA DVD-ROM drive or DVD+/-RW drive. NOTE: DVD devices are data only.
6	SD vFlash media card slot		Allows you to insert a vFlash media card.
7	LCD menu buttons		Allows you to navigate the control panel LCD menu.
8	Information tag		A slide-out label panel which that allows you to record system information, such as Service Tag, NIC, and MAC address.
9	LCD panel		Displays system ID, status information, and system error messages. The LCD lights blue during normal system operation. When the system needs attention, the LCD lights amber and the LCD panel displays an error code followed by descriptive text. NOTE: If the system is connected to AC power and an error is detected, the LCD lights amber regardless of whether the system is turned on or turned off.
10	Quick Sync (optional)		NOTE: By default, Quick Sync option is not available for Dell Storage NX3330 system. Indicates a Quick Sync-enabled system. The Quick Sync feature is optional and requires a Quick Sync bezel. This feature allows management of the system by using mobile devices. This feature aggregates hardware or firmware inventory and various system level diagnostic or error information that can be used in troubleshooting the system. For more information, see the <i>Integrated Dell Remote Access Controller User's Guide</i> at dell.com/esmmanuals .
11	Video connector		Allows you to connect a VGA display to the system.
12	HDDs (8)		Up to eight 2.5 inch hot-swappable HDDs.

LCD panel

The LCD panel of your system provides system information, status, and error messages to indicate if the system is functioning correctly or if the system needs attention. For more information about error messages, see the *Dell Event and Error Messages Reference Guide* at Dell.com/openmanagemanuals > **OpenManage software**.

- The LCD backlight turns blue during normal operating conditions.
- When the system needs attention, the LCD turns amber, and displays an error code followed by descriptive text.
NOTE: If the system is connected to a power source and an error is detected, the LCD turns amber regardless of whether the system is turned on or off.

- The LCD backlight is turned off when the system is in standby mode and can be turned on by pressing either the Select, Left, or Right button on the LCD panel.
- The LCD backlight remains off if LCD messaging is turned off using the iDRAC utility, the LCD panel, or other tools.

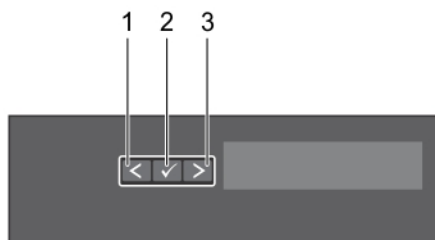

Figure 2. LCD panel features



Table 2. LCD panel features

Item	Button	Description
1	Left	Moves the cursor back in one-step increments.
2	Select	Selects the menu item highlighted by the cursor.
3	Right	Moves the cursor forward in one-step increments. During message scrolling: <ul style="list-style-type: none"> • Press and hold the button to increase scrolling speed. • Release the button to stop. <p>NOTE: The display stops scrolling when the button is released. After 45 seconds of inactivity, the display starts scrolling.</p>

Viewing Home screen

The **Home** screen displays user-configurable information about the system. This screen is displayed during normal system operation when there are no status messages or errors. When the system is in standby mode, the LCD backlight turns off after a few minutes of inactivity, if there are no error messages.

Steps

1. To view the **Home** screen, press one of the three navigation buttons (Select, Left, or Right).
2. To navigate to the **Home** screen from another menu, complete the following steps:
 - a. Press and hold the navigation button till the up arrow  is displayed.
 - b. Navigate to the  using the up arrow .
 - c. Select the **Home** icon.
 - d. On the **Home** screen, press the **Select** button to enter the main menu.

Setup menu

NOTE: When you select an option in the Setup menu, you must confirm the option before proceeding to the next action.

Option	Description
iDRAC	Select DHCP or Static IP to configure the network mode. If Static IP is selected, the available fields are IP , Subnet (Sub) , and Gateway (Gtw) . Select Setup DNS to enable DNS and to view domain addresses. Two separate DNS entries are available.
Set error	Select SEL to view LCD error messages in a format that matches the IPMI description in the SEL. This enables you to match an LCD message with an SEL entry.

Option	Description
	Select Simple to view LCD error messages in a simplified user-friendly description. For more information about error messages, see the <i>Dell Event and Error Messages Reference Guide</i> at Dell.com/openmanagemanuals > OpenManage software .
Set home	Select the default information to be displayed on the Home screen. See View menu section for the options and option items that can be set as the default on the Home screen.

Related references

[View menu](#) on page 10

View menu

NOTE: When you select an option in the View menu, you must confirm the option before proceeding to the next action.

Option	Description
iDRAC IP	Displays the IPv4 or IPv6 addresses for iDRAC8. Addresses include DNS (Primary and Secondary) , Gateway, IP , and Subnet (IPv6 does not have Subnet).
MAC	Displays the MAC addresses for iDRAC , iSCSI , or Network devices.
Name	Displays the name of the Host , Model , or User String for the system.
Number	Displays the Asset tag or the Service tag for the system.
Power	Displays the power output of the system in BTU/hr or Watts. The display format can be configured in the Set home submenu of the Setup menu.
Temperature	Displays the temperature of the system in Celsius or Fahrenheit. The display format can be configured in the Set home submenu of the Setup menu.

Back panel features and indicators

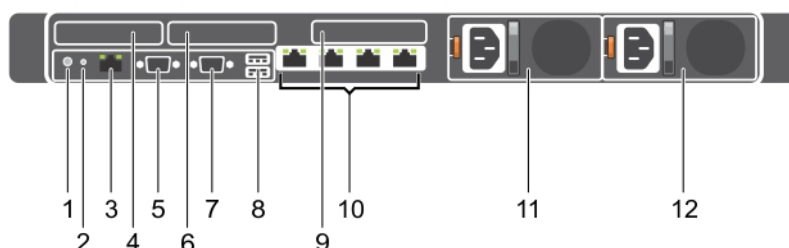







Figure 3. Back panel features and indicators—8 HDD system—3 PCIe expansion cards

Table 3. Back panel features and indicators

Item	Indicator, Button, or Connector	Icon	Description
1	System identification button		The identification buttons on the front-and back panels can be used to locate a particular system within a rack. When one of these buttons is pressed, the LCD panel on the front and the system status indicator on the back blinks until one of the buttons is pressed again.

Table 3. Back panel features and indicators (continued)

Item	Indicator, Button, or Connector	Icon	Description
			Press to toggle the system ID on and off. If the system stops responding during POST, press and hold the system ID button for more than five seconds to enter BIOS progress mode. To reset iDRAC (if not disabled on the iDRAC Setup page by pressing F2), press and hold for more than 15 seconds.
2	System identification connector		Allows you to connect the optional system status indicator assembly through the optional cable management arm.
3	iDRAC8 Enterprise port		Dedicated management port. i NOTE: The port is available for use only if the iDRAC8 Enterprise license is installed on your system.
4	LP PCIe expansion card slot (riser 1)		Allows you to connect a low profile PCIe expansion card.
5	Serial connector		Allows you to connect a serial device to the system.
6	LP PCIe expansion card slot (riser 2)		Allows you to connect a low profile PCIe expansion card.
7	Video connector		Allows you to connect a VGA display to the system.
8	USB connectors (2)		Allows you to connect USB drives to the system. The ports are USB 3.0-compliant.
9	LP PCIe expansion card slot (riser 3)		Allows you to connect a low profile PCIe expansion card.
10	Ethernet connectors (4)		Four integrated 10/100/1000 Mbps NIC connectors Or Four integrated connectors: <ul style="list-style-type: none"> • Two integrated 10/100/1000 Mbps NIC connectors • Two integrated 100 Mbps/1 Gbps/10 Gbps SFP+ connectors
11	PSU 1		750 W AC PSUs
12	PSU 2		750 W AC PSUs

Diagnostic indicators

The diagnostic indicators on the system front panel display error status during system startup.

i **NOTE:** The diagnostic indicators are not present if the system is equipped with an LCD display.

i **NOTE:** No diagnostic indicators are lit when the system is turned off. To start the system, plug it into a working power source and press the power button.

Table 4. Diagnostic indicators







Icon	Description	Condition	Corrective action
	Health indicator	If the system is turned on, and in good health, the indicator glows solid blue. The indicator blinks amber if the system is turned on or in standby,	None required. See the System Event Log or system messages for the specific issue. For more information about error

Table 4. Diagnostic indicators (continued)

Icon	Description	Condition	Corrective action
		and if any error exists (for example, a failed fan or HDD).	messages, see the <i>Dell Event and Error Messages Reference Guide</i> at Dell.com/esmmanuals . Invalid memory configurations can cause the system to stop responding at startup without any video output. See the Getting help section in this document.
	HDD indicator	The indicator blinks amber if a hard drive experiences an error.	See the System Event Log to determine the HDD that has an error. Run the appropriate Online Diagnostics test. Restart system and run embedded diagnostics (ePSA). If the HDDs are configured in a RAID array, restart the system and start the host adapter configuration utility program.
	Electrical indicator	The indicator blinks amber if the system experiences an electrical error (for example, voltage out of range, or a failed PSU or voltage regulator).	See the System Event Log or system messages for the specific issue. If it is because of an issue with the PSU, check the LED on the PSU. Reseat the PSU by removing and reinstalling it. If the issue persists, see the Getting help section in this document.
	Temperature indicator	The indicator blinks amber if the system experiences a thermal error (for example, a temperature out of range or fan failure).	Ensure that none of the following conditions exist: <ul style="list-style-type: none"> • A cooling fan is removed or has failed. • System cover, cooling shroud, EMI filler panel, memory-module blank, or back-filler bracket is removed. • Ambient temperature is too high. • External airflow is obstructed. See the Getting help section in this document.
	Memory indicator	The indicator blinks amber if a memory error occurs.	See the system event log or system messages for the location of the failed memory. Reinstall the memory device. If the issue persists, see the Getting help section in this document.
	PCIe indicator	The indicator blinks amber if a PCIe card experiences an error.	Restart the system. Update any required drivers for the PCIe card. Reinstall the card. If the issue persists, see the Getting help section in this document. NOTE: For more information on supported PCIe cards, see the Expansion Card Installation Guidelines section in this document.

Related references

[Getting help](#) on page 129

Hard drive indicator codes

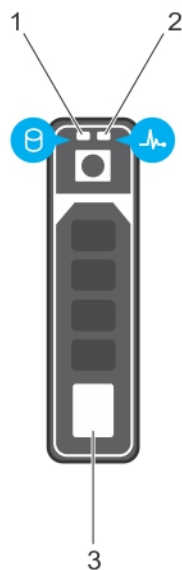

Figure 4. Hard drive indicators

1. Hard drive activity indicator
2. Hard drive status indicator
3. Hard drive

NOTE: If the hard drive is in Advanced Host Controller Interface (AHCI) mode, the status indicator (on the right side) does not function and remains turned off.

Table 5. Hard drive indicator codes

Drive-status indicator pattern (RAID only)	Condition
Blinks green two times per second	Identifying drive or preparing for removal.
Off	Drive ready for insertion or removal. NOTE: The drive status indicator remains off until all hard drives are initialized after the system is turned on. Drives are not ready for insertion or removal during this time.
Blinks green, amber, and turns off	Predicted drive failure
Blinks amber four times per second	Drive failed
Blinks green slowly	Drive rebuilding
Steady green	Drive online
Blinks green three seconds, amber three seconds, and turns off six seconds	Rebuild aborted

iDRAC Direct LED indicator codes

The iDRAC Direct LED indicator lights up to indicate that the port is connected and is being used as a part of the iDRAC subsystem.

iDRAC Direct LED indicator is located below the iDRAC Direct port on the right control panel. You can configure iDRAC Direct using a USB to micro USB (type AB) cable, which you can connect to your laptop or tablet. The following table describes iDRAC Direct activity when the iDRAC Direct port is active:

iDRAC Direct LED indicator code	Condition
Solid green for two seconds	Indicates that the laptop or tablet is connected.
Flashing green (on for two seconds and off for two seconds)	Indicates that the laptop or tablet that is connected is recognized.
Turns off	Indicates that the laptop or tablet is unplugged.

NIC indicator codes

Indicators on each NIC provide information about the activity and link status. The activity LED indicator indicates if data is flowing through the NIC, and the link LED indicator indicates the speed of the connected network.

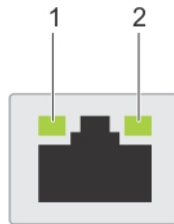

Figure 5. NIC indicator codes

1. link LED indicator
2. activity LED indicator

Status	Condition
Link and activity indicators are off	The NIC is not connected to the network.
Link indicator is green and activity indicator is blinking green	The NIC is connected to a valid network at its maximum port speed and data is being sent or received.
Link indicator is amber and activity indicator is blinking green	The NIC is connected to a valid network at less than its maximum port speed and data is being sent or received.
Link indicator is green and activity indicator is off	The NIC is connected to a valid network at its maximum port speed and data is not being sent or received.
Link indicator is amber and activity indicator is off	The NIC is connected to a valid network at less than its maximum port speed and data is not being sent or received.
Link indicator is blinking green and activity is off	NIC identify is enabled through the NIC configuration utility.

Power supply unit indicator codes

AC power supply units (PSUs) have an illuminated translucent handle that serves as an indicator and DC PSUs have an LED that serves as an indicator. The indicator shows whether power is present or a power fault has occurred.



Figure 6. AC PSU status indicator

1. AC PSU status indicator/handle

Table 6. AC PSU status indicators

Convention	Power indicator pattern	Condition
A	Green	A valid power source is connected to the PSU and the PSU is operational.
B	Flashing green	When the firmware of the PSU is being updated, the PSU handle flashes green.
C	Flashing green and turns off	When hot-adding a PSU, the PSU handle flashes green five times at 4 Hz rate and turns off. This indicates a PSU mismatch with respect to efficiency, feature set, health status, and supported voltage. <i>i</i> NOTE: Ensure that both the PSUs are of the same capacity. ⚠ CAUTION: For AC PSUs, use only PSUs with the Extended Power Performance (EPP) label on the back. <i>i</i> NOTE: Mixing PSUs from previous generations of Dell PowerEdge servers can result in a PSU mismatch condition or failure to turn the system on.
D	Flashing amber	Indicates a problem with the PSU. ⚠ CAUTION: When correcting a PSU mismatch, replace only the PSU with the flashing indicator. Swapping the PSU to make a matched pair can result in an error condition and unexpected system shutdown. To change from a high output configuration to a low output configuration or vice versa, you must turn off the system. ⚠ CAUTION: AC PSUs support both 220 V and 110 V input voltages with the exception of Titanium PSUs, which support only 220 V. When two identical PSUs receive different input voltages, they can output different wattages, and trigger a mismatch. ⚠ CAUTION: If two PSUs are used, they must be of the same type and have the same maximum output power. ⚠ CAUTION: Combining AC and DC PSUs is not supported and triggers a mismatch.
E	Not lit	Power is not connected.

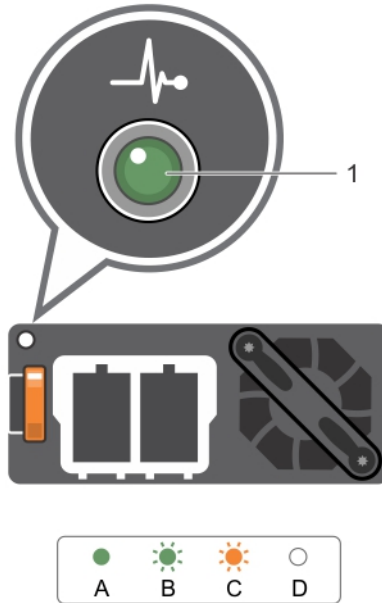

Figure 7. DC PSU status indicator

1. DC PSU status indicator

Table 7. DC PSU status indicators

Convention	Power indicator pattern	Condition
A	Green	A valid power source is connected to the PSU and that the PSU is operational.
B	Flashing green	When hot-adding a PSU, the PSU indicator flashes green. This indicates that there is a PSU mismatch with respect to efficiency, feature set, health status, and supported voltage. Ensure that both the PSUs are of the same capacity.
C	Flashing amber	Indicates a problem with the PSU. ⚠️ CAUTION: When correcting a PSU mismatch, replace only the PSU with the flashing indicator. Swapping the PSU to make a matched pair can result in an error condition and unexpected system shutdown. To change from a High Output configuration to a Low Output configuration or vice versa, you must turn off the system. ⚠️ CAUTION: AC PSU support both 220 V and 110 V input voltages with the exception of Titanium PSU, which support only 220 V. When two identical PSU receive different input voltages, they can output different wattages, and trigger a mismatch. ⚠️ CAUTION: If two PSU are used, they must be of the same type and have the same maximum output power. ⚠️ CAUTION: Combining AC and DC PSU is not supported and triggers a mismatch.
D	Not lit	Power is not connected.

Locating your system Service Tag

Your system is identified by a unique Express Service Code and Service Tag number. The Express Service Code and Service Tag are found on the front of the system by pulling out the information tag. Alternatively, the information may be on a sticker on the chassis of the system. This information is used by Dell to route support calls to the appropriate personnel.

Documentation resources

This section provides information about the documentation resources for your system.

Task	Document	Location
Setting up your system	For information about installing the system into a rack, see the Rack documentation included with your rack solution. . For information about setting up your system, see the <i>Getting Started Guide</i> document that is shipped with your system	www.dell.com/storagemanuals
Configuring your system	For information about configuring, managing, updating, and restoring the system, see the <i>Dell EMC Network Attached Storage System using Windows Storage Server 2016 Administrator's Guide</i> . For information about the iDRAC features, configuring and logging in to iDRAC, and managing your system remotely, see the <i>Integrated Dell Remote Access Controller User's Guide</i> . For information about understanding Remote Access Controller Admin (RACADM) subcommands and supported RACADM interfaces, see the <i>RACADM Command Line Reference Guide for iDRAC</i> . For information about updating drivers and firmware.	www.dell.com/storagemanuals www.dell.com/idracmanuals www.dell.com/idracmanuals www.dell.com/support/drivers
Managing your system	For information about the features of the Dell OpenManage Systems Management, see the <i>Dell OpenManage Systems Management Overview Guide</i> . For information about setting up, using, and troubleshooting OpenManage, see the <i>Dell OpenManage Server Administrator User's Guide</i> . For information about installing, using, and troubleshooting Dell OpenManage Essentials, see the <i>Dell OpenManage Essentials User's Guide</i> . For information about installing and using Dell SupportAssist, see the <i>Dell EMC SupportAssist Enterprise User's Guide</i> . For understanding the features of Dell Lifecycle Controller, see the <i>Dell Lifecycle Controller User's Guide</i> . For information about enterprise systems management partner programs, see the <i>OpenManage Connections Enterprise Systems Management documents</i> .	www.dell.com/openmanagemanuals >OpenManage Essentials www.dell.com/openmanagemanuals >OpenManage Server Administrator www.dell.com/openmanagemanuals >OpenManage Essentials www.dell.com/serviceabilitytools www.dell.com/idracmanuals www.dell.com/openmanagemanuals

Task	Document	Location
	For information about connections and client systems management, see the OpenManage Connections Client Systems Management documentation.	www.dell.com/dellclientcommandsuite/manuals
Working with the Dell EMC PowerEdge RAID controllers	For information about understanding the features of the Dell PowerEdge RAID controllers (PERC) and deploying the PERC cards, see the Storage controller documentation.	www.dell.com/storagecontroller/manuals
Understanding event and error messages	For information about the event and error messages that are generated by the system firmware and agents that monitor system components, see the Error Code Lookup.	www.dell.com/qr
Troubleshooting your system	For information about troubleshooting the hardware issues, see the <i>Dell EMC Network Attached Storage Systems using Windows Storage Server 2016 Troubleshooting Guide</i> .	www.dell.com/storage/manuals

Technical specifications

Table 8. Processor specification

Processor

Processor type	Two Intel Haswell processor E5-2600 v3 product family
----------------	---

Table 9. Expansion bus specification

Expansion Bus

Bus type	PCIe Generation 3
Expansion cards	For a list of supported expansion cards, see the Expansion card installation guidelines section in this document.

Expansion slots using riser card:

Riser 1	(Slot 1) One half-height, three fourth-length x8 link (Slot 2) One half-height, half-length x16 link
Riser 2	(Slot 1) One half-height, half-length x8 link or one half-height, half-length x8 link i NOTE: Both processors must be installed to use the slots on riser 1 and the x16 link on riser 2. (Slot 2) One half-height, half-length x8 link or one half-height, half-length x16 link
Riser 3	(Slot 2) One half-height, half-length x8 link or one half-height, half-length x16 link

Table 10. Power specification

Power

AC PSU (per PSU)	
Wattage	750 W
Heat dissipation	2891 BTU/hr maximum (750 W PSU) 2843 BTU/hr maximum (750 W Titanium PSU)
i NOTE: Heat dissipation is calculated using the PSU wattage rating.	
Voltage	100–240 V AC, autoranging, 50/60 Hz
i NOTE: This system is also designed to be connected to IT power systems with a phase to phase voltage not exceeding 230 V.	Or 200–240 V AC, autoranging, 50/60 Hz, for 750 W Titanium PSU

Table 11. Memory specification

Memory

Architecture	1866 MT/ and 2133 MT/s registered Error Correcting Code (ECC) DIMMs Support for Advanced ECC or memory-optimized operation Support for LRDIMMs
Memory module sockets	Twenty-four 288-pin
Memory module capacities	

Table 11. Memory specification (continued)

Memory	
LRDIMM	4 GB, 8 GB, 16 GB, or 32 GB single-, dual-, or quad-ranked
RDIMM	4 GB, 8 GB, or 32 GB single-, dual-, or quad-ranked 16 GB single- or dual-ranked
Minimum RAM	2 GB with a single processor 4 GB with two processors
Maximum RAM	
LRDIMM	Up to 768 GB
RDIMM	Up to 512 GB

Table 12. Drive specification

Drives	
HDDs	
8—HDD systems	Up to eight 2.5 inch, internal, hot-swappable SAS, SATA, or Nearline SAS HDDs
Optical drive	One optional SATA DVD-ROM drive or DVD+/-RW drive i NOTE: DVD devices are data only.

Table 13. Connector specification

Connectors	
Back	
NIC	Four 10/100/1000 Mbps or two 10/100/1000 Mbps and two 100 Mbps/1 Gbps/10 Gbps
Serial	DB-9 Serial Port connector
USB	Two 4-pin, USB 3.0-compliant
Video	15-pin VGA
Front	
8 HDD systems	
USB	Two 4-pin, USB 3.0-compliant
Video	15-pin VGA
External vFlash card	vFlash memory card slot i NOTE: The card slot is available for use only if the iDRAC8 Enterprise license is installed on your system.
Internal	
USB	One 4-pin, USB 3.0-compliant
Internal Dual SD Module (IDSDM)	Two optional flash memory card slots with the internal SD module i NOTE: One card slot is dedicated for redundancy.

Table 14. Video specification

Video	
Video type	Integrated VGA controller
Video memory	16 MB shared

Table 15. Expanded operating temperature

Expanded Operating Temperature

<p>i NOTE: When operating in the expanded temperature range, system performance may be impacted.</p>	
<p>i NOTE: When operating in the expanded temperature range, ambient temperature warnings may be reported on the LCD and in the System Event Log.</p>	
<p>≤ 10% of annual operating hours</p>	<p>Continuous Operation 5 °C–40°C at 5% to 85% RH with 29°C dew point.</p> <p>i NOTE: Outside the standard operating temperature (10°C–35°C), the system can operate continuously down to 5°C or as high as 40°C.</p> <p>For temperatures between 35°C- 40°C, derate maximum allowable temperature by 1°C per 175 m above 950 m (1°F per 319 ft).</p>
<p>≤ 1% of annual operating hours</p>	<p>–5 °C–45°C at 5% to 90% RH with 29°C (84.2°F) maximum dew point.</p> <p>i NOTE: Outside the standard operating temperature (10°C–35°C), the system can operate down to –5°C or up to 45°C for a maximum of 1% of its annual operating hours.</p> <p>For temperatures between 40 °C–45 °C, derate maximum allowable dry bulb temperature by 1°C per 125 m above 950 m (1°F per 228 ft).</p>
<p>Expanded Operating Temperature Restrictions</p>	<ul style="list-style-type: none"> • Do not perform a cold startup below 5°C. • The operating temperature specified is for a maximum altitude of 30482000 m (10,0006560 ft). • PCIe SSD and 1.8-inch SSDs are not supported. • GPU is not supported. • 145 W and Workstation CPU (160 W) processors are not supported. • Two PSUs are required and one PSU failure is not supported. • Non-Dell qualified peripheral cards and/or peripheral cards greater than 25 W are not supported.

Table 16. Environmental specification

Environmental

i **NOTE:** For additional information about environmental measurements for specific system configurations, see [Dell.com/environmental_datasheets](https://www.dell.com/environmental_datasheets).

Temperature

Maximum temperature gradient (operating and storage)	20°C/h (36°F/h)
Storage temperature limits	–40°C–65°C (–40°F–149°F)

Relative humidity

Storage	5% to 95% RH with 33°C (91 °F) maximum dew point. Atmosphere must be non-condensing always.
---------	---

Temperature (continuous operation)

Temperature ranges (for altitude less than 950 m or 3117 ft)	10 °C–35°C (50 °F–95°F) with no direct sunlight on the equipment.
Humidity percentage range	10% to 80% Relative Humidity with 26°C (78.8°F) maximum dew point.

Table 16. Environmental specification (continued)

Environmental

Maximum vibration

Operating	0.26 G _{rms} at 5 Hz to 350 Hz (all operation orientations).
Storage	1.87 G _{rms} at 10 Hz to 500 Hz for 15 min (all six sides tested).

Maximum shock

Operating	One shock pulse in the positive z axis of 31 G for 2.6 ms in all operational orientations.
Storage	Six consecutively executed shock pulses in the positive and negative x, y, and z axes (one pulse on each side of the system) of 71 G for up to 2 ms.

Maximum altitude

Operating	3,0482000 m (10,0006560 ft)
Storage	12,000 m (39,370 ft).

Operating altitude de-rating

Up to 35°C (95°F)	Maximum temperature is reduced by 1°C/300 m (1°F/547 ft) above 950 m (3,117 ft).
35 °C–40°C (95 °F–104°F)	Maximum temperature is reduced by 1°C/175 m (1°F/319 ft) above 950 m (3,117 ft).
40 °C–45°C (104 °F–113°F)	Maximum temperature is reduced by 1°C/125 m (1°F/228 ft) above 950 m (3,117 ft).

Particulate contamination

i **NOTE:** This section defines the limits to help avoid IT equipment damage and/or failure from particulates and gaseous contamination. If it is determined that levels of particulates or gaseous pollution are beyond the limits specified below and are the reason for the damage and/or failures to your equipment, it may be necessary for you to re-mediate the environmental conditions that are causing the damage and/or failures. Re-mediation of environmental conditions will be the responsibility of the customer.

Air filtration

i **NOTE:** Applies to data center environments only. Air filtration requirements do not apply to IT equipment designed to be used outside a data center, in environments such as an office or factory floor.

Data center air filtration as defined by ISO Class 8 per ISO 14644-1 with a 95 percent upper confidence limit.

i **NOTE:** Air entering the data center must have MERV11 or MERV13 filtration.

Conductive dust

i **NOTE:** Applies to data center and non-data center environments.

Air must be free from conductive dust, zinc whiskers, or other conductive particles.

Corrosive dust

i **NOTE:** Applies to data center and non-data center environments.

- Air must be free of corrosive dust.
- Residual dust present in the air must have a deliquescent point less than 60% relative humidity.

Gaseous contamination

i **NOTE:** Maximum corrosive contaminant levels measured at ≤50% relative humidity.

Copper coupon corrosion rate	<300 Å/month per Class G1 as defined by ANSI/ISA71.04-1985.
Silver coupon corrosion rate	<200 Å/month as defined by AHSRAE TC9.9.

Related references

[Expansion card installation guidelines](#) on page 73

Initial system setup and configuration

Topics:

- [Setting up your system](#)
- [iDRAC configuration](#)
- [Options to install the operating system](#)
- [Manage your system](#)

Setting up your system

Complete the following steps to set up your system:

Steps

1. Unpack the system.
2. Install the system into the rack. For more information about installing the system into the rack, see your system *Rack Installation Placemat* at [Dell.com/poweredgemanuals](https://www.dell.com/poweredge/manuals).
3. Connect the peripherals to the system.
4. Connect the system to its electrical outlet.
5. Turn the system on by pressing the power button or by using iDRAC.
6. Turn on the attached peripherals.

iDRAC configuration

The Integrated Dell Remote Access Controller (iDRAC) is designed to make system administrators more productive and improve the overall availability of Dell systems. iDRAC alerts administrators to system issues, helps them perform remote system management, and reduces the need for physical access to the system.

Options to set up iDRAC IP address

You must configure the initial network settings based on your network infrastructure to enable the communication to and from iDRAC. You can set up the IP address by using one of the following interfaces:

Interfaces	Document/Section
iDRAC Settings utility	See <i>Dell Integrated Dell Remote Access Controller User's Guide</i> at Dell.com/idracmanuals
Dell Deployment Toolkit	See <i>Dell Deployment Toolkit User's Guide</i> at Dell.com/openmanagemanuals
Dell Lifecycle Controller	See <i>Dell Lifecycle Controller User's Guide</i> at Dell.com/idracmanuals
Chassis or Server LCD panel	See the LCD panel section

You must use the default iDRAC IP address 192.168.0.120 to configure the initial network settings, including setting up DHCP or a static IP for iDRAC.

NOTE: To access iDRAC, ensure that you install the iDRAC port card or connect the network cable to the Ethernet connector 1 on the system board.

 **NOTE:** Ensure that you change the default user name and password after setting up the iDRAC IP address.

Related references

[LCD panel](#) on page 8

Log in to iDRAC

You can log in to iDRAC as:

- iDRAC user
- Microsoft Active Directory user
- Lightweight Directory Access Protocol (LDAP) user

The default user name and password are `root` and `calvin`. You can also log in by using Single Sign-On or Smart Card.

 **NOTE:** You must have iDRAC credentials to log in to iDRAC.

For more information about logging in to iDRAC and iDRAC licenses, see the latest Integrated Dell Remote Access Controller User's Guide at [Dell.com/idracmanuals](https://www.dell.com/idracmanuals).

Options to install the operating system

If the system is shipped without an operating system, install the supported operating system by using one of the following resources:

Table 17. Resources to install the operating system

Resources	Location
Dell Systems Management Tools and Documentation media	Dell.com/operatingsystemmanuals
Dell Lifecycle Controller	Dell.com/idracmanuals
Dell OpenManage Deployment Toolkit	Dell.com/openmanagemanuals
Dell certified VMware ESXi	Dell.com/virtualizationsolutions
Supported operating systems on Dell PowerEdge systems	Dell.com/ossupport
Installation and How-to videos for supported operating systems on Dell PowerEdge systems	Supported Operating Systems for Dell PowerEdge Systems

Methods to download firmware and drivers

You can download the firmware and drivers by using any of the following methods:

Table 18. Firmware and drivers

Methods	Location
From the Dell Support site	Global Technical Support
Using Dell Remote Access Controller Lifecycle Controller (iDRAC with LC)	Dell.com/idracmanuals
Using Dell Repository Manager (DRM)	Dell.com/openmanagemanuals > OpenManage Deployment Toolkit
Using Dell OpenManage Essentials (OME)	Dell.com/openmanagemanuals > OpenManage Deployment Toolkit
Using Dell Server Update Utility (SUU)	Dell.com/openmanagemanuals > OpenManage Deployment Toolkit

Table 18. Firmware and drivers (continued)

Methods	Location
Using Dell OpenManage Deployment Toolkit (DTK)	Dell.com/openmanagemanuals > OpenManage Deployment Toolkit

Manage your system

This section provides the information about server management software.

Server Management Software	Description
OpenManage	<p>The Dell OpenManage Server Administrator provides a comprehensive one-to-one systems management solution for both local and remote servers and their storage controllers and Direct Attached Storage (DAS).</p> <p>For information about OpenManage documents, see Dell.com/openmanagemanuals.</p>
OpenManage Essentials	<p>Dell OpenManage Essentials is the newest one-to-many management console for managing Dell PowerEdge servers and direct-attached storage as it provides a simple and easy interface for system administrators to maximize the uptime and health of Dell systems.</p> <p>For information about OpenManage documents, see Dell.com/openmanagemanuals.</p>
Remote Access Controller with Dell Lifecycle Controller (iDRAC with LC)	<p>iDRAC with Dell Lifecycle Controller allows administrators to deploy, update, monitor, and manage Dell servers from any location without the use of agents in a one-to-one or one-to-many method. This out-of-band management allows the updates to be sent from Dell or appropriate third-party consoles directly to iDRAC with Dell Lifecycle Controller on a Dell PowerEdge server, regardless of the operating system that may or may not be running.</p> <p>For information about Remote Enterprise Systems Management documents, see Dell.com/idracmanuals.</p>
Partner Programs Enterprise Systems Management	<p>For information about OpenManage Connections Enterprise Systems Management documents, see Dell.com/omconnectionsenterprisesystemsmanagement.</p>
OpenManage Connections Client Systems Management	<p>For information about OpenManage Connections Client Systems Management documents, see Dell.com/dellclientcommandsuitemanuals.</p>

Pre-operating system management applications

You can manage basic settings and features of a system without booting to the operating system by using the system firmware.

Topics:

- [Options to manage the pre-operating system applications](#)
- [System Setup](#)
- [Dell Lifecycle Controller](#)
- [Boot Manager](#)
- [PXE boot](#)

Options to manage the pre-operating system applications

Your system has the following options to manage the pre-operating system applications:

- System Setup
- Boot Manager
- Dell Lifecycle Controller
- Preboot Execution Environment (PXE)

System Setup

By using the **System Setup** screen, you can configure the BIOS settings, iDRAC settings, and device settings of your system.

 **NOTE:** Help text for the selected field is displayed in the graphical browser by default. To view the help text in the text browser, press F1.

You can access system setup by using two methods:

- Standard graphical browser — The browser is enabled by default.
- Text browser — The browser is enabled by using Console Redirection.

Viewing System Setup

To view the **System Setup** screen, perform the following steps:

Steps

1. Turn on, or restart your system.
2. Press F2 immediately after you see the following message:

```
F2 = System Setup
```

 **NOTE:** If your operating system begins to load before you press F2, wait for the system to finish booting, and then restart your system and try again.

System Setup details

The **System Setup Main Menu** screen details are explained as follows:

Option	Description
System BIOS	Enables you to configure BIOS settings.
iDRAC Settings	Enables you to configure iDRAC settings. The iDRAC settings utility is an interface to set up and configure the iDRAC parameters by using UEFI (Unified Extensible Firmware Interface). You can enable or disable various iDRAC parameters by using the iDRAC settings utility. For more information about this utility, see <i>Integrated Dell Remote Access Controller User's Guide</i> at Dell.com/idracmanuals .
Device Settings	Enables you to configure device settings.

System BIOS

You can use the **System BIOS** screen to edit specific functions such as boot order, system password, setup password, set the RAID mode, and enable or disable USB ports.

Viewing System BIOS

To view the **System BIOS** screen, perform the following steps:

Steps

1. Turn on, or restart your system.
2. Press F2 immediately after you see the following message:

```
F2 = System Setup
```

NOTE: If your operating system begins to load before you press F2, wait for the system to finish booting, and then restart your system and try again.

3. On the **System Setup Main Menu** screen, click **System BIOS**.

System BIOS Settings details

About this task

The **System BIOS Settings** screen details are explained as follows:

Option	Description
System Information	Specifies information about the system such as the system model name, BIOS version, and Service Tag.
Memory Settings	Specifies information and options related to the installed memory.
Processor Settings	Specifies information and options related to the processor such as speed and cache size.
SATA Settings	Specifies options to enable or disable the integrated SATA controller and ports.
Boot Settings	Specifies options to specify the boot mode (BIOS or UEFI). Enables you to modify UEFI and BIOS boot settings.
Network Settings	Specifies options to change the network settings.
Integrated Devices	Specifies options to manage integrated device controllers and ports and specify related features and options.

Option	Description
Serial Communication	Specifies options to manage the serial ports and specify related features and options.
System Profile Settings	Specifies options to change the processor power management settings, memory frequency, and so on.
System Security	Specifies options to configure the system security settings, such as system password, setup password, Trusted Platform Module (TPM) security. It also manages the power and NMI buttons on the system.
Miscellaneous Settings	Specifies options to change the system date, time, and so on.

Boot Settings

You can use the **Boot Settings** screen to set the boot mode to either **BIOS** or **UEFI**. It also enables you to specify the boot order.

Viewing Boot Settings

To view the **Boot Settings** screen, perform the following steps:

Steps

1. Turn on, or restart your system.
2. Press F2 immediately after you see the following message:

```
F2 = System Setup
```

NOTE: If your operating system begins to load before you press F2, wait for the system to finish booting, and then restart your system and try again.



3. On the **System Setup Main Menu** screen, click **System BIOS**.
4. On the **System BIOS** screen, click **Boot Settings**.

Boot Settings details

About this task



The **Boot Settings** screen details are explained as follows:

Option	Description
Boot Mode	<p>Enables you to set the boot mode of the system.</p> <p>CAUTION: Switching the boot mode may prevent the system from booting if the operating system is not installed in the same boot mode.</p> <p>If the operating system supports UEFI, you can set this option to UEFI. Setting this field to BIOS allows compatibility with non-UEFI operating systems. This option is set to BIOS by default.</p> <p>NOTE: Setting this field to UEFI disables the BIOS Boot Settings menu. Setting this field to BIOS disables the UEFI Boot Settings menu.</p>
Boot Sequence Retry	Enables or disables the Boot Sequence Retry feature. If this option is set to Enabled and the system fails to boot, the system reattempts the boot sequence after 30 seconds. This option is set to Enabled by default.
Hard-Disk Failover	Specifies the hard drive that is booted in the event of a hard drive failure. The devices are selected in the Hard-Disk Drive Sequence on the Boot Option Setting menu. When this option is set to Disabled , only the first hard drive in the list is attempted to boot. When this option is set to Enabled , all hard drives

Option	Description
	are attempted to boot in the order selected in the Hard-Disk Drive Sequence . This option is not enabled for UEFI Boot Mode.
Boot Option Settings	Configures the boot sequence and the boot devices.
BIOS Boot Settings	Enables or disables BIOS boot options.  NOTE: This option is enabled only if the boot mode is BIOS.
UEFI Boot Settings	Enables or disables UEFI Boot options. The Boot options include IPv4 PXE and IPv6 PXE . This option is set to IPv4 by default.  NOTE: This option is enabled only if the boot mode is UEFI.

Choosing the system boot mode

System Setup enables you to specify one of the following boot modes for installing your operating system:

- BIOS boot mode (the default) is the standard BIOS-level boot interface.
 - Unified Extensible Firmware Interface (UEFI) (the default) boot mode is an enhanced 64-bit boot interface. If you have configured your system to boot to UEFI mode, it replaces the system BIOS.
1. From the **System Setup Main Menu**, click **Boot Settings**, and select **Boot Mode**.
 2. Select the boot mode you want the system to boot into.
 **CAUTION: Switching the boot mode may prevent the system from booting if the operating system is not installed in the same boot mode.**
 3. After the system boots in the specified boot mode, proceed to install your operating system from that mode.
 **NOTE:** Operating systems must be UEFI-compatible to be installed from the UEFI boot mode. DOS and 32-bit operating systems do not support UEFI and can only be installed from the BIOS boot mode.
 **NOTE:** For the latest information about supported operating systems, go to [Dell.com/ossupport](https://www.dell.com/ossupport).

Changing the boot order

You may have to change the boot order if you want to boot from a USB key or an optical drive. The following instructions may vary if you have selected **BIOS** for **Boot Mode**.

Steps

1. On the **System Setup Main Menu** screen, click **System BIOS > Boot Settings**.
2. Click **Boot Option Settings > Boot Sequence**.
3. Use the arrow keys to select a boot device, and use the plus (+) and minus (-) sign keys to move the device down or up in the order.
4. Click **Exit**, and then click **Yes** to save the settings on exit.

Network Settings

You can use the **Network Settings** screen to modify PXE device settings. The network settings option is available only in the UEFI mode.

- 
- NOTE:**
- The BIOS does not control network settings in the BIOS mode. For the BIOS boot mode, the optional Boot ROM of the network controllers handles the network settings.

Viewing Network Settings

To view the **Network Settings** screen, perform the following steps:

Steps

1. Turn on, or restart your system.
2. Press F2 immediately after you see the following message:

```
F2 = System Setup
```

NOTE: If your operating system begins to load before you press F2, wait for the system to finish booting, and then restart your system and try again.

3. On the **System Setup Main Menu** screen, click **System BIOS**.
4. On the **System BIOS** screen, click **Network Settings**.

Network Settings screen details

The **Network Settings** screen details are explained as follows:

About this task

Option	Description
PXE Device n (n = 1 to 4)	Enables or disables the device. When enabled, a UEFI boot option is created for the device.
PXE Device n Settings(n = 1 to 4)	Enables you to control the configuration of the PXE device.

UEFI iSCSI Settings

You can use the iSCSI Settings screen to modify iSCSI device settings. The iSCSI Settings option is available only in the UEFI boot mode. BIOS does not control network settings in the BIOS boot mode. For the BIOS boot mode, the option ROM of the network controller handles the network settings.

Viewing UEFI iSCSI Settings

To view the **UEFI iSCSI Settings** screen, perform the following steps:

Steps

1. Turn on, or restart your system.
2. Press F2 immediately after you see the following message:

```
F2 = System Setup
```

NOTE: If your operating system begins to load before you press F2, wait for the system to finish booting, and then restart your system and try again.

3. On the **System Setup Main Menu** screen, click **System BIOS**.
4. On the **System BIOS** screen, click **Network Settings**.
5. On the **Network Settings** screen, click **UEFI iSCSI Settings**.

UEFI iSCSI Settings details

The **UEFI iSCSI Settings** screen details are explained as follows:

Option	Description
iSCSI Initiator Name	Specifies the name of the iSCSI initiator (iqn format).
iSCSI Device n (n = 1 to 4)	Enables or disables the iSCSI device. When disabled, a UEFI boot option is created for the iSCSI device automatically.

System Security

You can use the **System Security** screen to perform specific functions such as setting the system password, setup password and disabling the power button.

Viewing System Security

To view the **System Security** screen, perform the following steps:

Steps

1. Turn on, or restart your system.
2. Press F2 immediately after you see the following message:

```
F2 = System Setup
```



 **NOTE:** If your operating system begins to load before you press F2, wait for the system to finish booting, and then restart your system and try again.

3. On the **System Setup Main Menu** screen, click **System BIOS**.
4. On the **System BIOS** screen, click **System Security**.

System Security Settings details

About this task

The **System Security Settings** screen details are explained as follows:

Option	Description
Intel AES-NI	Improves the speed of applications by performing encryption and decryption by using the Advanced Encryption Standard Instruction Set (AES-NI). This option is set to Enabled by default.
System Password	Sets the system password. This option is set to Enabled by default and is read-only if the password jumper is not installed in the system.
Setup Password	Sets the setup password. This option is read-only if the password jumper is not installed in the system.
Password Status	Locks the system password. This option is set to Unlocked by default.
TPM Security	 NOTE: The TPM menu is available only when the TPM module is installed. Enables you to control the reporting mode of the TPM. The TPM Security option is set to Off by default. You can only modify the TPM Status, TPM Activation, and Intel TXT fields if the TPM Status field is set to either On with Pre-boot Measurements or On without Pre-boot Measurements .
TPM Information	Changes the operational state of the TPM. This option is set to No Change by default.
TPM Status	Specifies the TPM status.
TPM Command	 CAUTION: Clearing the TPM results in the loss of all keys in the TPM. The loss of TPM keys may affect booting to the operating system.

Option	Description
	Clears all the contents of the TPM. The TPM Clear option is set to No by default.
Intel TXT	Enables or disables the Intel Trusted Execution Technology (TXT) option. To enable the Intel TXT option, virtualization technology and TPM Security must be enabled with Pre-boot measurements. This option is set to Off by default.
Power Button	Enables or disables the power button on the front of the system. This option is set to Enabled by default.
NMI Button	Enables or disables the NMI button on the front of the system. This option is set to Disabled by default.
AC Power Recovery	Sets how the system behaves after AC power is restored to the system. This option is set to Last by default.
AC Power Recovery Delay	Sets the time delay for the system to power up after AC power is restored to the system. This option is set to Immediate by default.
User Defined Delay (60s to 240s)	Sets the User Defined Delay option when the User Defined option for AC Power Recovery Delay is selected.
UEFI Variable Access	Provides varying degrees of securing UEFI variables. When set to Standard (the default), UEFI variables are accessible in the operating system per the UEFI specification. When set to Controlled , selected UEFI variables are protected in the environment and new UEFI boot entries are forced to be at the end of the current boot order.
Secure Boot	Enables Secure Boot, where the BIOS authenticates each pre-boot image by using the certificates in the Secure Boot Policy. Secure Boot is disabled by default.
Secure Boot Policy	When Secure Boot policy is set to Standard , the BIOS uses the system manufacturer's key and certificates to authenticate pre-boot images. When Secure Boot policy is set to Custom , the BIOS uses the user-defined key and certificates. Secure Boot policy is set to Standard by default.
Secure Boot Policy Summary	Specifies the list of certificates and hashes that secure boot uses to authenticate images.

Secure Boot Custom Policy Settings

Secure Boot Custom Policy Settings is displayed only when **Secure Boot Policy** is set to **Custom**.

Viewing Secure Boot Custom Policy Settings

To view the **Secure Boot Custom Policy Settings** screen, perform the following steps:

Steps

1. Turn on, or restart your system.
2. Press F2 immediately after you see the following message:

```
F2 = System Setup
```

 **NOTE:** If your operating system begins to load before you press F2, wait for the system to finish booting, and then restart your system and try again.

3. On the **System Setup Main Menu** screen, click **System BIOS**.
4. On the **System BIOS** screen, click **System Security**.
5. On the **System Security** screen, click **Secure Boot Custom Policy Settings**.

Secure Boot Custom Policy Settings details

The **Secure Boot Custom Policy Settings** screen details are explained as follows:

Option	Description
Platform Key	Imports, exports, deletes, or restores the platform key (PK).

Option	Description
Key Exchange Key Database	Enables you to import, export, delete, or restore entries in the Key Exchange Key (KEK) Database.
Authorized Signature Database	Imports, exports, deletes, or restores entries in the Authorized Signature Database (db).
Forbidden Signature Database	Imports, exports, deletes, or restores entries in the Forbidden Signature Database (dbx).

Creating a system and setup password

Prerequisites

Ensure that the password jumper is enabled. The password jumper enables or disables the system password and setup password features. For more information, see the System board jumper settings section.

 **NOTE:** If the password jumper setting is disabled, the existing system password and setup password are deleted and you need not provide the system password to boot the system.

Steps

1. To enter System Setup, press F2 immediately after turning on or rebooting your system.
2. On the **System Setup Main Menu** screen, click **System BIOS > System Security**.
3. On the **System Security** screen, verify that **Password Status** is set to **Unlocked**.
4. In the **System Password** field, type your system password, and press Enter or Tab.

Use the following guidelines to assign the system password:

- A password can have up to 32 characters.
- The password can contain the numbers 0 through 9.
- Only the following special characters are allowed: space, ("), (+), (.), (-), (.), (/), (:), ([), (\), (]), (`).

A message prompts you to reenter the system password.

5. Reenter the system password, and click **OK**.
6. In the **Setup Password** field, type your setup password and press Enter or Tab. A message prompts you to reenter the setup password.
7. Reenter the setup password, and click **OK**.
8. Press Esc to return to the System BIOS screen. Press Esc again. A message prompts you to save the changes.

 **NOTE:** Password protection does not take effect until the system reboots.

Using your system password to secure your system

About this task

If you have assigned a setup password, the system accepts your setup password as an alternate system password.

Steps

1. Turn on or reboot your system.
2. Type the system password and press Enter.

Next steps

When **Password Status** is set to **Locked**, type the system password and press Enter when prompted at reboot.

NOTE: If an incorrect system password is typed, the system displays a message and prompts you to reenter your password. You have three attempts to type the correct password. After the third unsuccessful attempt, the system displays an error message that the system has stopped functioning and must be turned off. Even after you turn off and restart the system, the error message is displayed until the correct password is entered.

Deleting or changing system and setup password

Prerequisites

NOTE: You cannot delete or change an existing system or setup password if the **Password Status** is set to **Locked**.

Steps

1. To enter System Setup, press F2 immediately after turning on or restarting your system.
2. On the **System Setup Main Menu** screen, click **System BIOS > System Security**.
3. On the **System Security** screen, ensure that **Password Status** is set to **Unlocked**.
4. In the **System Password** field, alter or delete the existing system password, and then press Enter or Tab.
5. In the **Setup Password** field, alter or delete the existing setup password, and then press Enter or Tab.
If you change the system and setup password, a message prompts you to reenter the new password. If you delete the system and setup password, a message prompts you to confirm the deletion.
6. Press Esc to return to the **System BIOS** screen. Press Esc again, and a message prompts you to save the changes.

Operating with a setup password enabled

If **Setup Password** is set to **Enabled**, type the correct setup password before modifying the system setup options.

If you do not type the correct password in three attempts, the system displays the following message:

```
Invalid Password! Number of unsuccessful password attempts: <x> System Halted! Must power down.
```

Even after you turn off and restart the system, the error message is displayed until the correct password is typed. The following options are exceptions:

- If **System Password** is not set to **Enabled** and is not locked through the **Password Status** option, you can assign a system password. For more information, see the System Security Settings screen section.
- You cannot disable or change an existing system password.

NOTE: You can use the password status option with the setup password option to protect the system password from unauthorized changes.

Related tasks

[System Security Settings details](#) on page 31

System Information

You can use the **System Information** screen to view system properties such as Service Tag, system model name, and the BIOS version.

Viewing System Information

To view the **System Information** screen, perform the following steps:

Steps

1. Turn on, or restart your system.

2. Press F2 immediately after you see the following message:

```
F2 = System Setup
```

NOTE: If your operating system begins to load before you press F2, wait for the system to finish booting, and then restart your system and try again.

- 3. On the **System Setup Main Menu** screen, click **System BIOS**.
- 4. On the **System BIOS** screen, click **System Information**.

System Information details

About this task

The **System Information** screen details are explained as follows:

Option	Description
System Model Name	Specifies the system model name.
System BIOS Version	Specifies the BIOS version installed on the system.
System Management Engine Version	Specifies the current version of the Management Engine firmware.
System Service Tag	Specifies the system Service Tag.
System Manufacturer	Specifies the name of the system manufacturer.
System Manufacturer Contact Information	Specifies the contact information of the system manufacturer.
System CPLD Version	Specifies the current version of the system complex programmable logic device (CPLD) firmware.
UEFI Compliance Version	Specifies the UEFI compliance level of the system firmware.

Memory Settings

You can use the **Memory Settings** screen to view all the memory settings and enable or disable specific memory functions, such as system memory testing and node interleaving.

Viewing Memory Settings

To view the **Memory Settings** screen, perform the following steps:

Steps

- 1. Turn on, or restart your system.
- 2. Press F2 immediately after you see the following message:

```
F2 = System Setup
```

NOTE: If your operating system begins to load before you press F2, wait for the system to finish booting, and then restart your system and try again.

3. On the **System Setup Main Menu** screen, click **System BIOS**.
4. On the **System BIOS** screen, click **Memory Settings**.

Memory Settings details

About this task

The **Memory Settings** screen details are explained as follows:

Option	Description
System Memory Size	Specifies the memory size in the system.
System Memory Type	Specifies the type of memory installed in the system.
System Memory Speed	Specifies the system memory speed.
System Memory Voltage	Specifies the system memory voltage.
Video Memory	Specifies the amount of video memory.
System Memory Testing	Specifies whether the system memory tests are run during system boot. Options are Enabled and Disabled . This option is set to Disabled by default.
Memory Operating Mode	Specifies the memory operating mode. The options available are Optimizer Mode , Advanced ECC Mode , Mirror Mode , Spare Mode , Spare with Advanced ECC Mode , Dell Fault Resilient Mode and Dell NUMA Fault Resilient Mode . This option is set to Optimizer Mode by default. <i>i</i> NOTE: The Memory Operating Mode option can have different default and available options based on the memory configuration of your system. <i>i</i> NOTE: The Dell Fault Resilient Mode option establishes an area of memory that is fault resilient. This mode can be used by an operating system that supports the feature to load critical applications or enables the operating system kernel to maximize system availability.
Node Interleaving	Specifies if Non-Uniform Memory architecture (NUMA) is supported. If this field is set to Enabled , memory interleaving is supported if a symmetric memory configuration is installed. If the field is set to Disabled , the system supports NUMA (asymmetric) memory configurations. This option is set to Disabled by default.
Snoop Mode	Specifies the Snoop Mode options. The Snoop Mode options available are Home Snoop , Early Snoop , and Cluster on Die . This option is set to Early Snoop by default. This field is available only when the Node Interleaving is set to Disabled .

Processor Settings

You can use the **Processor Settings** screen to view the processor settings, and perform specific functions such as enabling virtualization technology, hardware prefetcher, and logical processor idling.

Viewing Processor Settings

To view the **Processor Settings** screen, perform the following steps:

Steps

1. Turn on, or restart your system.
2. Press F2 immediately after you see the following message:

```
F2 = System Setup
```



 **NOTE:** If your operating system begins to load before you press F2, wait for the system to finish booting, and then restart your system and try again.

3. On the **System Setup Main Menu** screen, click **System BIOS**.
4. On the **System BIOS** screen, click **Processor Settings**.

Processor Settings details

About this task

The **Processor Settings** screen details are explained as follows:

Option	Description
Logical Processor	Enables or disables the logical processors and displays the number of logical processors. If this option is set to Enabled , the BIOS displays all the logical processors. If this option is set to Disabled , the BIOS displays only one logical processor per core. This option is set to Enabled by default.
QPI Speed	Enables you to control QuickPath Interconnect data rate settings.
Alternate RTID (Requestor Transaction ID) Setting	Modifies Requestor Transaction IDs, which are QPI resources. This option is set to Disabled by default.  NOTE: Enabling this option may negatively impact the overall system performance.
Virtualization Technology	Enables or disables the additional hardware capabilities provided for virtualization. This option is set to Enabled by default.
Address Translation Service (ATS)	Defines the Address Translation Cache (ATC) for devices to cache the DMA transactions. This option provides an interface between CPU and DMA Memory Management to a chipset's Address Translation and Protection Table to translate DMA addresses to host addresses. This option is set to Enabled by default.
Adjacent Cache Line Prefetch	Optimizes the system for applications that need high utilization of sequential memory access. This option is set to Enabled by default. You can disable this option for applications that need high utilization of random memory access.
Hardware Prefetcher	Enables or disables the hardware prefetcher. This option is set to Enabled by default.
DCU Streamer Prefetcher	Enables or disables the Data Cache Unit (DCU) streamer prefetcher. This option is set to Enabled by default.
DCU IP Prefetcher	Enables or disables the Data Cache Unit (DCU) IP prefetcher. This option is set to Enabled by default.
Execute Disable	Enables you to run the disable memory protection technology. This option is set to Enabled by default.
Logical Processor Idling	Enables you to improve the energy efficiency of a system. It uses the operating system core parking algorithm and parks some of the logical processors in the system which in turn allows the corresponding processor cores to transition into a lower power idle state. This option can only be enabled if the operating system supports it. It is set to Disabled by default.
Configurable TDP	Enables you to reconfigure the processor Thermal Design Power (TDP) levels during POST based on the power and thermal delivery capabilities of the system. TDP verifies the maximum heat the cooling system is needed to dissipate. This option is set to Nominal by default.  NOTE: This option is only available on certain stock keeping units (SKUs) of the processors.
X2Apic Mode	Enables or disables the X2Apic mode.
Dell Controlled Turbo	Controls the turbo engagement. Enable this option only when System Profile is set to Performance .  NOTE: Depending on the number of installed CPUs, there may be up to four processor listings.
Number of Cores per Processor	Controls the number of enabled cores in each processor. This option is set to All by default.
Processor 64-bit Support	Specifies if the processor(s) support 64-bit extensions.

Option	Description
Processor Core Speed	Specifies the maximum core frequency of the processor.
Processor 1	 NOTE: Depending on the number of CPUs, there may be up to four processors listed. The following settings are displayed for each processor installed in the system:
Option	Description
Family-Model-Stepping	Specifies the family, model, and stepping of the processor as defined by Intel.
Brand	Specifies the brand name.
Level 2 Cache	Specifies the total L2 cache.
Level 3 Cache	Specifies the total L3 cache.
Number of Cores	Specifies the number of cores per processor.

SATA Settings

You can use the **SATA Settings** screen to view the SATA settings of SATA devices and enable RAID on your system.

Viewing SATA Settings

To view the **SATA Settings** screen, perform the following steps:

Steps

1. Turn on, or restart your system.
2. Press F2 immediately after you see the following message:

```
F2 = System Setup
```

 **NOTE:** If your operating system begins to load before you press F2, wait for the system to finish booting, and then restart your system and try again.

3. On the **System Setup Main Menu** screen, click **System BIOS**.
4. On the **System BIOS** screen, click **SATA Settings**.

SATA Settings details

About this task

The **SATA Settings** screen details are explained as follows:

Option	Description
Embedded SATA	Enables the embedded SATA option to be set to Off , ATA , AHCI , or RAID modes. This option is set to AHCI by default.
Security Freeze Lock	Sends Security Freeze Lock command to the Embedded SATA drives during POST. This option is applicable only for ATA and AHCI modes.
Write Cache	Enables or disables the command for Embedded SATA drives during POST.
Port A	Sets the drive type of the selected device. For Embedded SATA settings in ATA mode, set this field to Auto to enable BIOS support. Set it to OFF to turn off BIOS support. For AHCI or RAID mode, BIOS support is always enabled.

Option	Description								
	<table border="0"> <thead> <tr> <th style="text-align: left;">Option</th> <th style="text-align: left;">Description</th> </tr> </thead> <tbody> <tr> <td>Model</td> <td>Specifies the drive model of the selected device.</td> </tr> <tr> <td>Drive Type</td> <td>Specifies the type of drive attached to the SATA port.</td> </tr> <tr> <td>Capacity</td> <td>Specifies the total capacity of the hard drive. This field is undefined for removable media devices such as optical drives.</td> </tr> </tbody> </table>	Option	Description	Model	Specifies the drive model of the selected device.	Drive Type	Specifies the type of drive attached to the SATA port.	Capacity	Specifies the total capacity of the hard drive. This field is undefined for removable media devices such as optical drives.
Option	Description								
Model	Specifies the drive model of the selected device.								
Drive Type	Specifies the type of drive attached to the SATA port.								
Capacity	Specifies the total capacity of the hard drive. This field is undefined for removable media devices such as optical drives.								
Port B	<p>Sets the drive type of the selected device. For Embedded SATA settings in ATA mode, set this field to Auto to enable BIOS support. Set it to OFF to turn off BIOS support.</p> <p>For AHCI or RAID mode, BIOS support is always enabled.</p> <table border="0"> <thead> <tr> <th style="text-align: left;">Option</th> <th style="text-align: left;">Description</th> </tr> </thead> <tbody> <tr> <td>Model</td> <td>Specifies the drive model of the selected device.</td> </tr> <tr> <td>Drive Type</td> <td>Specifies the type of drive attached to the SATA port.</td> </tr> <tr> <td>Capacity</td> <td>Specifies the total capacity of the hard drive. This field is undefined for removable media devices such as optical drives.</td> </tr> </tbody> </table>	Option	Description	Model	Specifies the drive model of the selected device.	Drive Type	Specifies the type of drive attached to the SATA port.	Capacity	Specifies the total capacity of the hard drive. This field is undefined for removable media devices such as optical drives.
Option	Description								
Model	Specifies the drive model of the selected device.								
Drive Type	Specifies the type of drive attached to the SATA port.								
Capacity	Specifies the total capacity of the hard drive. This field is undefined for removable media devices such as optical drives.								
Port C	<p>Sets the drive type of the selected device. For Embedded SATA settings in ATA mode, set this field to Auto to enable BIOS support. Set it to OFF to turn off BIOS support.</p> <p>For AHCI or RAID mode, BIOS support is always enabled.</p> <table border="0"> <thead> <tr> <th style="text-align: left;">Option</th> <th style="text-align: left;">Description</th> </tr> </thead> <tbody> <tr> <td>Model</td> <td>Specifies the drive model of the selected device.</td> </tr> <tr> <td>Drive Type</td> <td>Specifies the type of drive attached to the SATA port.</td> </tr> <tr> <td>Capacity</td> <td>Specifies the total capacity of the hard drive. This field is undefined for removable media devices such as optical drives.</td> </tr> </tbody> </table>	Option	Description	Model	Specifies the drive model of the selected device.	Drive Type	Specifies the type of drive attached to the SATA port.	Capacity	Specifies the total capacity of the hard drive. This field is undefined for removable media devices such as optical drives.
Option	Description								
Model	Specifies the drive model of the selected device.								
Drive Type	Specifies the type of drive attached to the SATA port.								
Capacity	Specifies the total capacity of the hard drive. This field is undefined for removable media devices such as optical drives.								
Port D	<p>Sets the drive type of the selected device. For Embedded SATA settings in ATA mode, set this field to Auto to enable BIOS support. Set it to OFF to turn off BIOS support.</p> <p>For AHCI or RAID mode, BIOS support is always enabled.</p> <table border="0"> <thead> <tr> <th style="text-align: left;">Option</th> <th style="text-align: left;">Description</th> </tr> </thead> <tbody> <tr> <td>Model</td> <td>Specifies the drive model of the selected device.</td> </tr> <tr> <td>Drive Type</td> <td>Specifies the type of drive attached to the SATA port.</td> </tr> <tr> <td>Capacity</td> <td>Specifies the total capacity of the hard drive. This field is undefined for removable media devices such as optical drives.</td> </tr> </tbody> </table>	Option	Description	Model	Specifies the drive model of the selected device.	Drive Type	Specifies the type of drive attached to the SATA port.	Capacity	Specifies the total capacity of the hard drive. This field is undefined for removable media devices such as optical drives.
Option	Description								
Model	Specifies the drive model of the selected device.								
Drive Type	Specifies the type of drive attached to the SATA port.								
Capacity	Specifies the total capacity of the hard drive. This field is undefined for removable media devices such as optical drives.								
Port E	<p>Sets the drive type of the selected device. For Embedded SATA settings in ATA mode, set this field to Auto to enable BIOS support. Set it to OFF to turn off BIOS support.</p> <p>For AHCI or RAID mode, BIOS support is always enabled.</p> <table border="0"> <thead> <tr> <th style="text-align: left;">Option</th> <th style="text-align: left;">Description</th> </tr> </thead> <tbody> <tr> <td>Model</td> <td>Specifies the drive model of the selected device.</td> </tr> <tr> <td>Drive Type</td> <td>Specifies the type of drive attached to the SATA port.</td> </tr> <tr> <td>Capacity</td> <td>Specifies the total capacity of the hard drive. This field is undefined for removable media devices such as optical drives.</td> </tr> </tbody> </table>	Option	Description	Model	Specifies the drive model of the selected device.	Drive Type	Specifies the type of drive attached to the SATA port.	Capacity	Specifies the total capacity of the hard drive. This field is undefined for removable media devices such as optical drives.
Option	Description								
Model	Specifies the drive model of the selected device.								
Drive Type	Specifies the type of drive attached to the SATA port.								
Capacity	Specifies the total capacity of the hard drive. This field is undefined for removable media devices such as optical drives.								
Port F	<p>Sets the drive type of the selected device. For Embedded SATA settings in ATA mode, set this field to Auto to enable BIOS support. Set it to OFF to turn off BIOS support.</p> <p>For AHCI or RAID mode, BIOS support is always enabled.</p>								

Option	Description								
	<table border="1"> <thead> <tr> <th>Option</th> <th>Description</th> </tr> </thead> <tbody> <tr> <td>Model</td> <td>Specifies the drive model of the selected device.</td> </tr> <tr> <td>Drive Type</td> <td>Specifies the type of drive attached to the SATA port.</td> </tr> <tr> <td>Capacity</td> <td>Specifies the total capacity of the hard drive. This field is undefined for removable media devices such as optical drives.</td> </tr> </tbody> </table>	Option	Description	Model	Specifies the drive model of the selected device.	Drive Type	Specifies the type of drive attached to the SATA port.	Capacity	Specifies the total capacity of the hard drive. This field is undefined for removable media devices such as optical drives.
Option	Description								
Model	Specifies the drive model of the selected device.								
Drive Type	Specifies the type of drive attached to the SATA port.								
Capacity	Specifies the total capacity of the hard drive. This field is undefined for removable media devices such as optical drives.								
Port G	<p>Sets the drive type of the selected device. For Embedded SATA settings in ATA mode, set this field to Auto to enable BIOS support. Set it to OFF to turn off BIOS support.</p> <p>For AHCI or RAID mode, BIOS support is always enabled.</p> <table border="1"> <thead> <tr> <th>Option</th> <th>Description</th> </tr> </thead> <tbody> <tr> <td>Model</td> <td>Specifies the drive model of the selected device.</td> </tr> <tr> <td>Drive Type</td> <td>Specifies the type of drive attached to the SATA port.</td> </tr> <tr> <td>Capacity</td> <td>Specifies the total capacity of the hard drive. This field is undefined for removable media devices such as optical drives.</td> </tr> </tbody> </table>	Option	Description	Model	Specifies the drive model of the selected device.	Drive Type	Specifies the type of drive attached to the SATA port.	Capacity	Specifies the total capacity of the hard drive. This field is undefined for removable media devices such as optical drives.
Option	Description								
Model	Specifies the drive model of the selected device.								
Drive Type	Specifies the type of drive attached to the SATA port.								
Capacity	Specifies the total capacity of the hard drive. This field is undefined for removable media devices such as optical drives.								
Port H	<p>Sets the drive type of the selected device. For Embedded SATA settings in ATA mode, set this field to Auto to enable BIOS support. Set it to OFF to turn off BIOS support.</p> <p>For AHCI or RAID mode, BIOS support is always enabled.</p> <table border="1"> <thead> <tr> <th>Option</th> <th>Description</th> </tr> </thead> <tbody> <tr> <td>Model</td> <td>Specifies the drive model of the selected device.</td> </tr> <tr> <td>Drive Type</td> <td>Specifies the type of drive attached to the SATA port.</td> </tr> <tr> <td>Capacity</td> <td>Specifies the total capacity of the hard drive. This field is undefined for removable media devices such as optical drives.</td> </tr> </tbody> </table>	Option	Description	Model	Specifies the drive model of the selected device.	Drive Type	Specifies the type of drive attached to the SATA port.	Capacity	Specifies the total capacity of the hard drive. This field is undefined for removable media devices such as optical drives.
Option	Description								
Model	Specifies the drive model of the selected device.								
Drive Type	Specifies the type of drive attached to the SATA port.								
Capacity	Specifies the total capacity of the hard drive. This field is undefined for removable media devices such as optical drives.								
Port I	<p>Sets the drive type of the selected device. For Embedded SATA settings in ATA mode, set this field to Auto to enable BIOS support. Set it to OFF to turn off BIOS support.</p> <p>For AHCI or RAID mode, BIOS support is always enabled.</p> <table border="1"> <thead> <tr> <th>Option</th> <th>Description</th> </tr> </thead> <tbody> <tr> <td>Model</td> <td>Specifies the drive model of the selected device.</td> </tr> <tr> <td>Drive Type</td> <td>Specifies the type of drive attached to the SATA port.</td> </tr> <tr> <td>Capacity</td> <td>Specifies the total capacity of the hard drive. This field is undefined for removable media devices such as optical drives.</td> </tr> </tbody> </table>	Option	Description	Model	Specifies the drive model of the selected device.	Drive Type	Specifies the type of drive attached to the SATA port.	Capacity	Specifies the total capacity of the hard drive. This field is undefined for removable media devices such as optical drives.
Option	Description								
Model	Specifies the drive model of the selected device.								
Drive Type	Specifies the type of drive attached to the SATA port.								
Capacity	Specifies the total capacity of the hard drive. This field is undefined for removable media devices such as optical drives.								
Port J	<p>Sets the drive type of the selected device. For Embedded SATA settings in ATA mode, set this field to Auto to enable BIOS support. Set it to OFF to turn off BIOS support.</p> <p>For AHCI or RAID mode, BIOS support is always enabled.</p> <table border="1"> <thead> <tr> <th>Option</th> <th>Description</th> </tr> </thead> <tbody> <tr> <td>Model</td> <td>Specifies the drive model of the selected device.</td> </tr> <tr> <td>Drive Type</td> <td>Specifies the type of drive attached to the SATA port.</td> </tr> <tr> <td>Capacity</td> <td>Specifies the total capacity of the hard drive. This field is undefined for removable media devices such as optical drives.</td> </tr> </tbody> </table>	Option	Description	Model	Specifies the drive model of the selected device.	Drive Type	Specifies the type of drive attached to the SATA port.	Capacity	Specifies the total capacity of the hard drive. This field is undefined for removable media devices such as optical drives.
Option	Description								
Model	Specifies the drive model of the selected device.								
Drive Type	Specifies the type of drive attached to the SATA port.								
Capacity	Specifies the total capacity of the hard drive. This field is undefined for removable media devices such as optical drives.								

Integrated Devices

You can use the **Integrated Devices** screen to view and configure the settings of all integrated devices including the video controller, integrated RAID controller, and the USB ports.

Viewing Integrated Devices

To view the **Integrated Devices** screen, perform the following steps:

Steps

1. Turn on, or restart your system.
2. Press F2 immediately after you see the following message:

```
F2 = System Setup
```

NOTE: If your operating system begins to load before you press F2, wait for the system to finish booting, and then restart your system and try again.

3. On the **System Setup Main Menu** screen, click **System BIOS**.
4. On the **System BIOS** screen, click **Integrated Devices**.

Integrated Devices details

About this task

The **Integrated Devices** screen details are explained as follows:

Option	Description
USB 3.0 Setting	Enables or disables the USB 3.0 support. Enable this option only if your operating system supports USB 3.0. If you disable this option, devices operate at USB 2.0 speed. USB 3.0 is enabled by default.
User Accessible USB Ports	Enables or disables the USB ports. Selecting Only Back Ports On disables the front USB ports, selecting All Ports Off disables all USB ports. The USB keyboard and mouse operate during boot process in certain operating systems. After the boot process is complete, the USB keyboard and mouse do not work if the ports are disabled. NOTE: Selecting Only Back Ports On and All Ports Off disables the USB management port and also restricts access to iDRAC features.
Internal USB Port	Enables or disables the internal USB port. This option is set to Enabled by default.
Integrated RAID Controller	Enables or disables the integrated RAID controller. This option is set to Enabled by default.
Integrated Network Card 1	Enables or disables the integrated network card.
Embedded NIC1 and NIC2	NOTE: The Embedded NIC1 and NIC2 options are only available on systems that do not have Integrated Network Card 1 . Enables or disables the Embedded NIC1 and NIC2 options. If set to Disabled , the NIC may still be available for shared network access by the embedded management controller. The embedded NIC1 and NIC2 options are only available on systems that do not have Network Daughter Cards (NDCs). The Embedded NIC1 and NIC2 option is mutually exclusive with the Integrated Network Card 1 option. Configure the Embedded NIC1 and NIC2 option by using the NIC management utilities of the system.
I/OAT DMA Engine	Enables or disables the I/OAT option. Enable only if the hardware and software support the feature.
Embedded Video Controller	Enables or disables the Embedded Video Controller option. This option is set to Enabled by default.

Option	Description
Current State of Embedded Video Controller	Displays the current state of the embedded video controller. The Current State of Embedded Video Controller option is a read-only field. If the Embedded Video Controller is the only display capability in the system (that is, no add-in graphics card is installed), then the Embedded Video Controller is automatically used as the primary display even if the Embedded Video Controller setting is set to Disabled .
SR-IOV Global Enable	Enables or disables the BIOS configuration of Single Root I/O Virtualization (SR-IOV) devices. This option is set to Disabled by default.
OS Watchdog Timer	If your system stops responding, this watchdog timer aids in the recovery of your operating system. When this option is set to Enabled , the operating system initializes the timer. When this option is set to Disabled (the default), the timer does not have any effect on the system.
Memory Mapped I/O above 4 GB	Enables or disables the support for PCIe devices that need large amounts of memory. This option is set to Enabled by default.
Slot Disablement	Enables or disables the available PCIe slots on your system. The slot disablement feature controls the configuration of PCIe cards installed in the specified slot. Slots must be disabled only when the installed peripheral card prevents booting into the operating system or causes delays in system startup. If the slot is disabled, both the Option ROM and UEFI drivers are disabled.

Serial Communication

You can use the **Serial Communication** screen to view the properties of the serial communication port.

Viewing Serial Communication

To view the **Serial Communication** screen, perform the following steps:

Steps

1. Turn on, or restart your system.
2. Press F2 immediately after you see the following message:

```
F2 = System Setup
```



 **NOTE:** If your operating system begins to load before you press F2, wait for the system to finish booting, and then restart your system and try again.

3. On the **System Setup Main Menu** screen, click **System BIOS**.
4. On the **System BIOS** screen, click **Serial Communication**.

Serial Communication details

About this task

The **Serial Communication** screen details are explained as follows:

Option	Description
Serial Communication	Selects serial communication devices (Serial Device 1 and Serial Device 2) in BIOS. BIOS console redirection can also be enabled and the port address can be specified. This option is set to Auto by default.
Serial Port Address	Enables you to set the port address for serial devices. This option is set to Serial Device 1=COM2, Serial Device 2=COM1 by default. <ul style="list-style-type: none">  NOTE: You can use only Serial Device 2 for the Serial Over LAN (SOL) feature. To use console redirection by SOL, configure the same port address for console redirection and the serial device.  NOTE: Every time the system boots, the BIOS syncs the serial MUX setting saved in iDRAC. The serial MUX setting can independently be changed in iDRAC. Loading the BIOS default settings from

Option	Description
	within the BIOS setup utility may not always revert the serial MUX setting to the default setting of Serial Device 1.
External Serial Connector	<p>Enables you to associate the External Serial Connector to Serial Device 1, Serial Device 2, or the Remote Access Device by using this option.</p> <p>NOTE: Only Serial Device 2 can be used for Serial Over LAN (SOL). To use console redirection by SOL, configure the same port address for console redirection and the serial device.</p> <p>NOTE: Every time the system boots, the BIOS syncs the serial MUX setting saved in iDRAC. The serial MUX setting can independently be changed in iDRAC. Loading the BIOS default settings from within the BIOS setup utility may not always revert this setting to the default setting of Serial Device 1.</p>
Failsafe Baud Rate	Specifies the failsafe baud rate for console redirection. The BIOS attempts to determine the baud rate automatically. This failsafe baud rate is used only if the attempt fails, and the value must not be changed. This option is set to 115200 by default.
Remote Terminal Type	Sets the remote console terminal type. This option is set to VT 100/VT 220 by default.
Redirection After Boot	Enables or disables the BIOS console redirection when the operating system is loaded. This option is set to Enabled by default.

System Profile Settings

You can use the **System Profile Settings** screen to enable specific system performance settings such as power management.

Viewing System Profile Settings

To view the **System Profile Settings** screen, perform the following steps:

Steps

1. Turn on, or restart your system.
2. Press F2 immediately after you see the following message:

```
F2 = System Setup
```

NOTE: If your operating system begins to load before you press F2, wait for the system to finish booting, and then restart your system and try again.





3. On the **System Setup Main Menu** screen, click **System BIOS**.
4. On the **System BIOS** screen, click **System Profile Settings**.

System Profile Settings details

About this task

The **System Profile Settings** screen details are explained as follows:

Option	Description
System Profile	Sets the system profile. If you set the System Profile option to a mode other than Custom , the BIOS automatically sets the rest of the options. You can only change the rest of the options if the mode is set to Custom . This option is set to Performance Per Watt Optimized (DAPC) by default. DAPC is Dell Active Power Controller.

Option	Description
	<p> NOTE: All the parameters on the system profile setting screen are available only when the System Profile option is set to Custom.</p>
CPU Power Management	Sets the CPU power management. This option is set to System DBPM (DAPC) by default. DBPM is Demand-Based Power Management.
Memory Frequency	Sets the speed of the system memory. You can select Maximum Performance , Maximum Reliability , or a specific speed.
Turbo Boost	Enables or disables the processor to operate in the turbo boost mode. This option is set to Enabled by default.
Energy Efficient Turbo	Enables or disables the Energy Efficient Turbo option. Energy Efficient Turbo (EET) is a mode of operation where a processor's core frequency is adjusted to be within the turbo range based on workload.
C1E	Enables or disables the processor to switch to a minimum performance state when it is idle. This option is set to Enabled by default.
C States	Enables or disables the processor to operate in all available power states. This option is set to Enabled by default.
Collaborative CPU Performance Control	Enables or disables the CPU power management option. When set to Enabled , the CPU power management is controlled by the OS DBPM and the System DBPM (DAPC). This option is set to Disabled by default.
Memory Patrol Scrub	Sets the memory patrol scrub frequency. This option is set to Standard by default.
Memory Refresh Rate	Sets the memory refresh rate to either 1x or 2x. This option is set to 1x by default.
Uncore Frequency	Enables you to select the Processor Uncore Frequency option. Dynamic mode enables the processor to optimize power resources across the cores and uncore during runtime. The optimization of the uncore frequency to either save power or optimize performance is influenced by the setting of the Energy Efficiency Policy option.
Energy Efficient Policy	Enables you to select the Energy Efficient Policy option. The CPU uses the setting to manipulate the internal behavior of the processor and determines whether to target higher performance or better power savings.
Number of Turbo Boot Enabled Cores for Processor 1	<p> NOTE: If there are two processors installed in the system, you see an entry for Number of Turbo Boost Enabled Cores for Processor 2.</p> <p>Controls the number of turbo boost enabled cores for processor 1. The maximum number of cores is enabled by default.</p>
Monitor/Mwait	<p>Enables the Monitor/Mwait instructions in the processor. This option is set to Enabled for all system profiles, except Custom by default.</p> <p> NOTE: This option can be disabled only if the C States option in the Custom mode is set to disabled.</p> <p> NOTE: When C States is set to Enabled in the Custom mode, changing the Monitor/Mwait setting does not impact the system power or performance.</p>

Miscellaneous Settings

You can use the **Miscellaneous Settings** screen to perform specific functions such as updating the asset tag and changing the system date and time.

Viewing Miscellaneous Settings

To view the **Miscellaneous Settings** screen, perform the following steps:

Steps

1. Turn on, or restart your system.
2. Press F2 immediately after you see the following message:

```
F2 = System Setup
```

NOTE: If your operating system begins to load before you press F2, wait for the system to finish booting, and then restart your system and try again.

3. On the **System Setup Main Menu** screen, click **System BIOS**.
4. On the **System BIOS** screen, click **Miscellaneous Settings**.

Miscellaneous Settings details

About this task

The **Miscellaneous Settings** screen details are explained as follows:

Option	Description
System Time	Enables you to set the time on the system.
System Date	Enables you to set the date on the system.
Asset Tag	Specifies the asset tag and enables you to modify it for security and tracking purposes.
Keyboard NumLock	Enables you to set whether the system boots with the NumLock enabled or disabled. This option is set to On by default. NOTE: This option does not apply to 84-key keyboards.
F1/F2 Prompt on Error	Enables or disables the F1/F2 prompt on error. This option is set to Enabled by default. The F1/F2 prompt also includes keyboard errors.
Load Legacy Video Option ROM	Enables you to determine whether the system BIOS loads the legacy video (INT 10H) option ROM from the video controller. Selecting Enabled in the operating system does not support UEFI video output standards. This field is available only for UEFI boot mode. You cannot set the option to Enabled if UEFI Secure Boot mode is enabled.
In-System Characterization	Enables or disables In-System Characterization . This option is set to Disabled by default. The two other options are Enabled and Enabled - No Reboot . NOTE: The default setting for In-System Characterization is subject to change in future BIOS releases. When enabled, In-System Characterization (ISC) executes during POST upon detecting relevant change(s) in system configuration to optimize system power and performance. ISC takes about 20 seconds to execute, and system reset is needed for ISC results to be applied. The Enabled - No Reboot option executes ISC and continues without applying ISC results until the next time system reset occurs. The Enabled option executes ISC and forces an immediate system reset so that ISC results can be applied. It takes the system longer to be ready due to the forced system reset. When disabled, ISC does not execute.

iDRAC Settings utility

The iDRAC settings utility is an interface to set up and configure the iDRAC parameters by using UEFI. You can enable or disable various iDRAC parameters by using the iDRAC settings utility.

 **NOTE:** Accessing some of the features on the iDRAC settings utility needs the iDRAC Enterprise License upgrade.

For more information about using iDRAC, see *Dell Integrated Dell Remote Access Controller User's Guide* at [Dell.com/idracmanuals](https://www.dell.com/idracmanuals).

Entering the iDRAC Settings utility

Steps

1. Turn on or restart the managed system.
2. Press F2 during Power-on Self-test (POST).
3. On the **System Setup Main Menu** page, click **iDRAC Settings**.
The **iDRAC Settings** screen is displayed.

Changing the thermal settings

The iDRAC settings utility enables you to select and customize the thermal control settings for your system.

1. Click **iDRAC Settings > Thermal**.
2. Under **SYSTEM THERMAL PROFILE > Thermal Profile**, select one of the following options:
 - Default Thermal Profile Settings
 - Maximum Performance (Performance Optimized)
 - Minimum Power (Performance per Watt Optimized)
3. Under **USER COOLING OPTIONS**, set the **Fan Speed Offset**, **Minimum Fan Speed**, and **Custom Minimum Fan Speed**.
4. Click **Back > Finish > Yes**.

Device Settings

Device Settings enables you to configure device parameters.

Dell Lifecycle Controller

Dell Lifecycle Controller (LC) provides advanced embedded systems management capabilities including system deployment, configuration, update, maintenance, and diagnosis. LC is delivered as part of the iDRAC out-of-band solution and Dell system embedded Unified Extensible Firmware Interface (UEFI) applications.

Embedded systems management

The Dell Lifecycle Controller provides advanced embedded systems management throughout the system's lifecycle. The Dell Lifecycle Controller can be started during the boot sequence and can function independently of the operating system.

 **NOTE:** Certain platform configurations may not support the full set of features provided by the Dell Lifecycle Controller.

For more information about setting up the Dell Lifecycle Controller, configuring hardware and firmware, and deploying the operating system, see the Dell Lifecycle Controller documentation at [Dell.com/idracmanuals](https://www.dell.com/idracmanuals).

Boot Manager

The **Boot Manager** screen enables you to select boot options and diagnostic utilities.

Viewing Boot Manager

To enter **Boot Manager**:

Steps

1. Turn on, or restart your system.
2. Press F11 when you see the following message:

```
F11 = Boot Manager
```

If your operating system begins to load before you press F11, allow the system to complete the booting, and then restart your system and try again.

Boot Manager main menu

Menu item	Description
Continue Normal Boot	The system attempts to boot to devices starting with the first item in the boot order. If the boot attempt fails, the system continues with the next item in the boot order until the boot is successful or no more boot options are found.
One-shot Boot Menu	Enables you to access boot menu, where you can select a one-time boot device to boot from.
Launch System Setup	Enables you to access System Setup.
Launch Lifecycle Controller	Exits the Boot Manager and invokes the Dell Lifecycle Controller program.
System Utilities	Enables you to launch System Utilities menu such as System Diagnostics and UEFI shell.

One-shot BIOS boot menu

One-shot BIOS boot menu enables you to select a boot device to boot from.

System Utilities

System Utilities contains the following utilities that can be launched:

- Launch Diagnostics
- BIOS Update File Explorer
- Reboot System

PXE boot

You can use the Preboot Execution Environment (PXE) option to boot and configure the networked systems, remotely.

NOTE: To access the **PXE boot** option, boot the system and then press F12. The system scans and displays the active networked systems.

Installing and removing system components

This section provides information about installing and removing the system components.

Topics:

- Safety instructions
- Before working inside your system
- After working inside your system
- Recommended tools
- Front bezel (optional)
- Removing system cover
- Installing the system cover
- Inside system
- Cooling shroud
- System memory
- Hard disk drives
- Optical drive (optional)
- Cooling fans
- Expansion cards and expansion card riser
- SD vFlash card (optional)
- Integrated storage controller card
- Network daughter card
- Processors and heat sinks
- PSUs
- System battery
- Hard disk drive backplane
- Control panel
- VGA module
- System board
- Trusted Platform Module

Safety instructions

 **NOTE:** Whenever you need to lift the system, get others to assist you. To avoid injury, do not attempt to lift the system by yourself.

 **WARNING:** Opening or removing the system cover while the system is powered on may expose you to a risk of electric shock.

 **CAUTION:** Do not operate the system without the cover for a duration exceeding five minutes.

 **CAUTION:** Many repairs may only be done by a certified service technician. You should only perform troubleshooting and simple repairs as authorized in your product documentation, or as directed by the online or telephone service and support team. Damage due to servicing that is not authorized by Dell is not covered by your warranty. Read and follow the safety instructions that are shipped with your product.

 **NOTE:** Dell recommends that you always use a static mat and static strap while working on components inside the system.

 **NOTE:** To ensure proper operation and cooling, all bays in the system and system fans must be populated always with either a component or with a blank.

Before working inside your system

Prerequisites

Follow the safety guidelines listed in the Safety instructions section.

Steps

1. Turn off the system, including any attached peripherals.
2. Disconnect the system from the electrical outlet and disconnect the peripherals.
3. If installed, remove the front bezel.
4. If applicable, remove the system from the rack.
For more information, see the *Rack Installation* placemat at Dell.com/poweredgemanuals.
5. Remove the system cover.

Related references

[Safety instructions](#) on page 48

After working inside your system

Prerequisites

Follow the safety guidelines listed in the Safety instructions section.

Steps

1. Install the system cover.
2. If applicable, install the system into the rack.
For more information, see the *Rack Installation* placemat at Dell.com/poweredgemanuals.
3. If removed, install the front bezel.
4. Reconnect the peripherals and connect the system to the electrical outlet.
5. Turn on the system, including any attached peripherals.

Related references

[Safety instructions](#) on page 48

Recommended tools

You need the following tools to perform the removal and installation procedures:

- Key to the bezel lock.
The key is needed only if your system includes a bezel.
- Phillips #1 screwdriver
- Phillips #2 screwdriver
- Torx #T6, #T8, #T10, and #T15 screwdrivers
- Wrist grounding strap

You need the following tools to assemble the cables for a DC power supply unit.

- AMP 90871-1 hand-crimping tool or equivalent
 - Tyco Electronics 58433-3 or equivalent
 - Wire-stripper pliers to remove insulation from size 10 AWG solid or stranded, insulated copper wire
-  **NOTE:** Use alpha wire part number 3080 or equivalent (65/30 stranding).

Front bezel (optional)

The front bezel is attached to the front side of the server and prevents accidents while removing the hard drive or when pressing the reset or power button. The front bezel can also be locked for additional security.

Removing the optional front bezel

Prerequisites

Follow the safety guidelines listed in the Safety instructions section.

Steps

1. Locate and remove the bezel key.

NOTE: The bezel key is attached to the back of the bezel.

2. Unlock the bezel by using the key.
3. Slide the release latch up, and pull the left end of the bezel.
4. Unhook the right end, and remove the bezel.

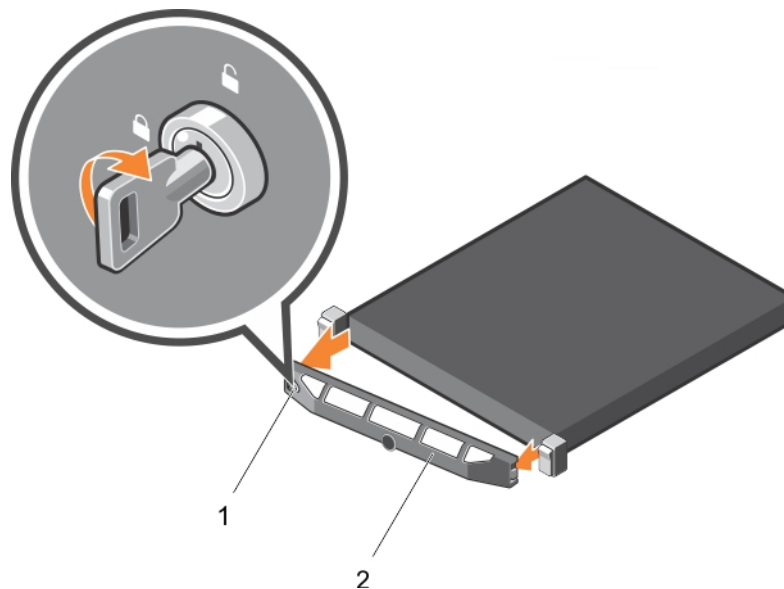

Figure 8. Removing the optional front bezel

- a. bezel lock
- b. front bezel

Related references

[Safety instructions](#) on page 48

Installing front bezel

Steps

1. Hook the right end of the bezel onto the chassis.
2. Fit the free end of the bezel onto the system.
3. Secure the bezel with the key lock.

Removing system cover

Prerequisites

1. Ensure that you read the Safety instructions section in this document.
2. Turn off the system, including any attached peripherals.
3. Disconnect the system from the electrical outlet and peripherals.
4. Remove the optional bezel. For more information, see the Removing the front bezel section in this document.

Steps

1. Turn the latch release lock to the unlock position.
2. Lift the cover release latch and remove the system cover.

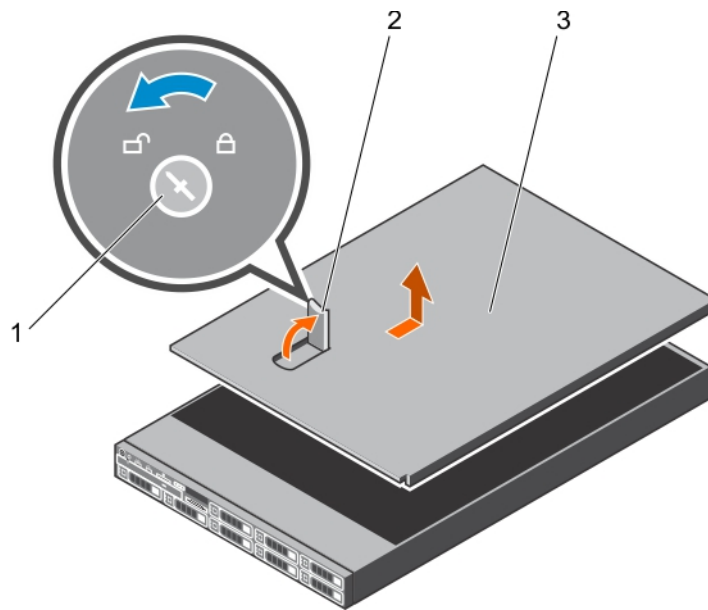

Figure 9. Removing and installing the system

- a. latch release lock
- b. system cover
- c. latch

Related references

[Safety instructions](#) on page 48

Related tasks

[Removing the optional front bezel](#) on page 50

Installing the system cover

Prerequisites

1. Follow the safety guidelines listed in the Safety instructions section.
2. Follow the procedure listed in the Before working inside your system section.
3. Ensure that all internal cables are connected and placed out of the way, and no tools or extra parts are left inside the system.

Steps

1. Align the slots on the system cover with the tabs on the chassis.
2. Push the system cover latch down.
The system cover slides forward and the slots on the system cover engage with the tabs on the chassis. The system cover latch locks into place when the system cover is completely engaged with the tabs on the chassis.
3. Rotate the latch release lock clockwise to the locked position.

Next steps

1. If removed, install the front bezel.
2. Reconnect the peripherals and connect the system to the electrical outlet.
3. Turn on the system, including any attached peripherals.
4. Follow the procedure listed in the After working inside your system section.

Related references

[Safety instructions](#) on page 48

Related tasks

[Before working inside your system](#) on page 49

[After working inside your system](#) on page 49

Inside system

 **CAUTION:** Many repairs may only be done by a certified service technician. You should only perform troubleshooting and simple repairs as authorized in your product documentation, or as directed by the online or telephone service and support team. Damage due to servicing that is not authorized by Dell is not covered by your warranty. Read and follow the safety instructions that are shipped with your product.

 **NOTE:** Components that are hot-swappable are marked orange and touch points on the components are marked blue.

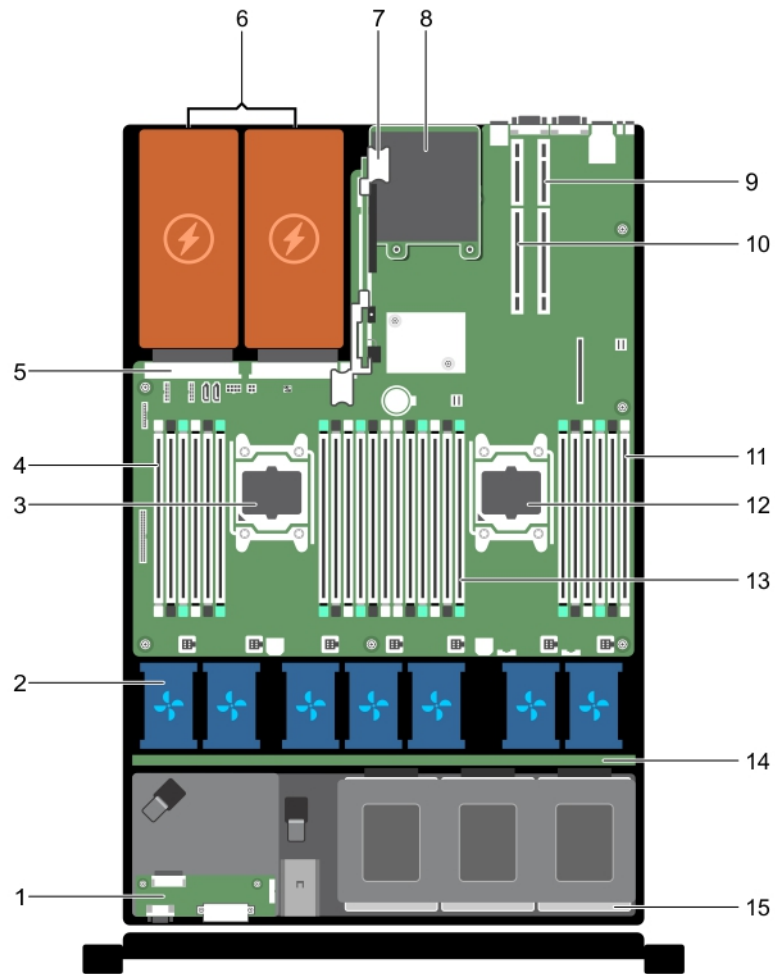

Figure 10. Inside the system — 8 HDD system



- | | |
|---------------------------|--------------------------|
| 1. control panel assembly | 2. cooling fans (7) |
| 3. processor 1 | 4. DIMMs (6) |
| 5. PSU connector | 6. PSU (2) |
| 7. riser card 3 | 8. network daughter card |
| 9. riser card 2 | 10. riser card 1 |
| 11. DIMMs (6) | 12. processor 2 |
| 13. DIMMs (12) | 14. HDD backplane |
| 15. HDD | |

Cooling shroud

The cooling shroud aerodynamically directs the airflow across the entire system. The airflow passes through all the critical parts of the system, where the vacuum pulls air across the entire surface area of the heat sink, thus allowing increased cooling.

Removing the cooling shroud

Prerequisites

-  **CAUTION:** Many repairs may only be done by a certified service technician. You should only perform troubleshooting and simple repairs as authorized in your product documentation, or as directed by the online or telephone service and support team. Damage due to servicing that is not authorized by Dell is not covered by your warranty. Read and follow the safety instructions that are shipped with your product.
-  **CAUTION:** Never operate your system with the cooling shroud removed. The system may get overheated quickly, resulting in shutdown of the system and loss of data.

1. Follow the safety guidelines listed in the Safety instructions section.
2. Follow the procedure listed in the Before working inside your system section.
3. If installed, remove the full-length PCIe card.

Steps

Holding the touch points, lift the cooling shroud away from the system.

Next steps

1. Install the cooling shroud.
2. If required, install the full-length PCIe card.
3. Follow the procedure listed in the After working inside your system section.

Related references

[Safety instructions](#) on page 48

Related tasks

[Before working inside your system](#) on page 49

[After working inside your system](#) on page 49

Installing the cooling shroud

Prerequisites

-  **CAUTION:** Many repairs may only be done by a certified service technician. You should only perform troubleshooting and simple repairs as authorized in your product documentation, or as directed by the online or telephone service and support team. Damage due to servicing that is not authorized by Dell is not covered by your warranty. Read and follow the safety instructions that are shipped with your product.

1. Follow the safety guidelines listed in the Safety instructions section.
2. Follow the procedure listed in the Before working inside your system section.
3. If applicable, route the cables inside the system along the chassis wall and secure the cables by using the cable-securing bracket.

Steps

1. Align the tabs on the cooling shroud with the securing slots on the chassis.
2. Lower the cooling shroud into the chassis until it is firmly seated.

Next steps

1. If removed, install the full-length PCIe card.
2. Follow the procedure listed in the After working inside your system section.

Related references

[Safety instructions](#) on page 48

Related tasks

[Before working inside your system](#) on page 49

[After working inside your system](#) on page 49

System memory

The system supports DDR4 registered DIMMs (RDIMMs) and load reduced DIMMs (LRDIMMs). System memory holds the instructions that are executed by the processor.

 **NOTE:** MT/s indicates DIMM speed in MegaTransfers per second.

Memory bus operating frequency can be 1866 MT/s, 2133 MT/s, or 2400 MT/s depending on the following factors:

- DIMM type (RDIMM or LRDIMM)
- Number of DIMMs populated per channel
- System profile selected (for example, Performance Optimized, Custom, or Dense Configuration Optimized)
- Maximum supported DIMM frequency of the processors

Your system contains 24 memory sockets split into two sets of 12 sockets, one set per processor. Each 12-socket set is organized into four channels. In each channel, the release tabs of the first socket are marked white, the second socket black, and the third socket green.

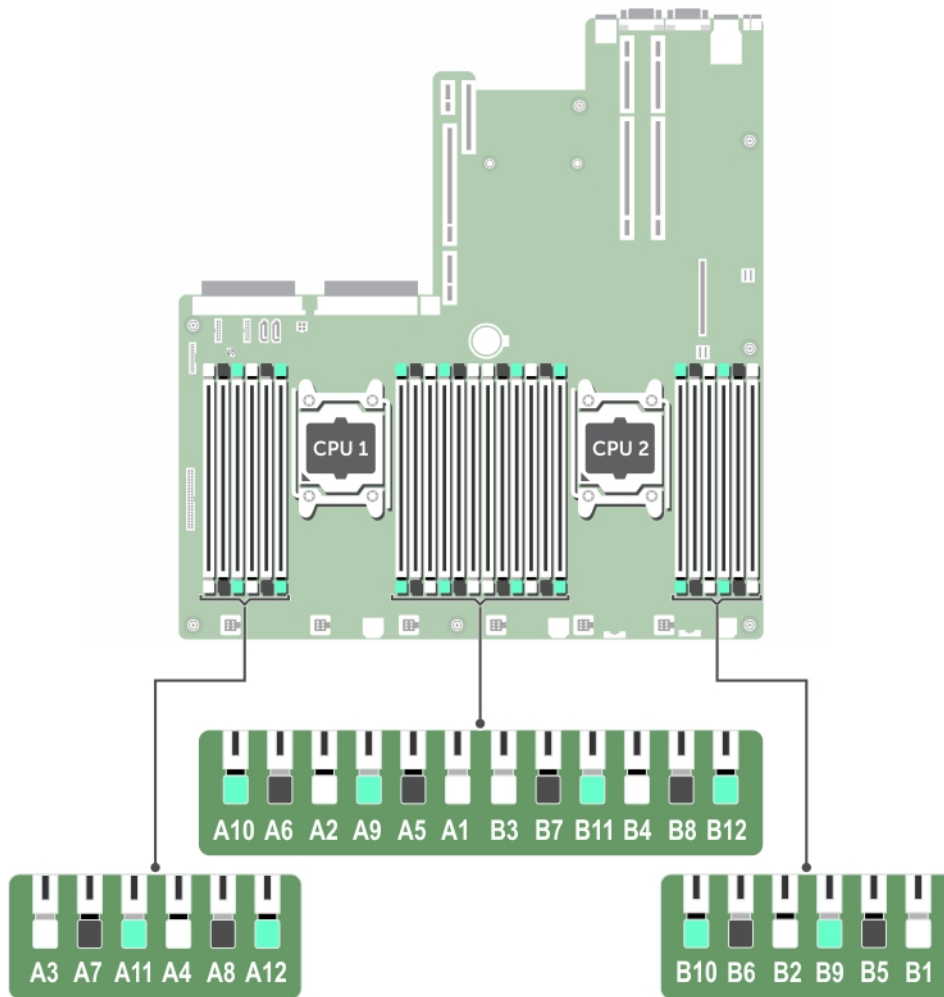

Figure 11. Memory socket locations

Memory channels are organized as follows:

Table 19. Memory channels

Processor	Channel 0	Channel 1	Channel 2	Channel 3
Processor 1	Slots A1, A5, and A9	Slots A2, A6, and A10	Slots A3, A7, and A11	Slots A4, A8, and A12
Processor 2	Slots B1, B5, and B9	Slots B2, B6, and B10	Slots B3, B7, and B11	Slots B4, B8, and B12

The following table shows the memory populations and operating frequencies for the supported configurations:

Table 20. Memory population

DIMM Type	DIMMs Populated/ Channel	Voltage	Operating Frequency (in MT/s)	Maximum DIMM Rank/ Channel
RDIMM	1	1.2 V	2400, 2133, 1866	Dual rank or single rank
	2		2400, 2133, 1866	Dual rank or single rank
	3		1866	Dual rank or single rank
LRDIMM	1	1.2 V	2400, 2133, 1866	Quad rank
	2		2400, 2133, 1866	Quad rank
	3		2133, 1866	Quad rank

General memory module installation guidelines

NOTE: Memory configurations that fail to observe these guidelines can prevent your system from booting, stop responding during memory configuration, or operating with reduced memory.

The system supports Flexible Memory Configuration, enabling the system to be configured and run in any valid chipset architectural configuration. The following are the recommended guidelines for installing memory modules:

- RDIMMs and LRDIMMs must not be mixed.
- x4 and x8 DRAM based memory modules can be mixed. For more information, see the Mode-specific guidelines section.
- Up to three dual- or single-rank RDIMMs can be populated per channel.
- Up to three LRDIMMs can be populated per channel regardless of rank count.
- If memory modules with different speeds are installed, they will operate at the speed of the slowest installed memory module(s) or slower depending on system DIMM configuration.
- Populate memory module sockets only if a processor is installed. For single-processor systems, sockets A1 to A12 are available. For dual-processor systems, sockets A1 to A12 and sockets B1 to B12 are available.
- Populate all the sockets with white release tabs first, followed by the black release tabs, and then the green release tabs.
- When mixing memory modules with different capacities, populate the sockets with memory modules with highest capacity first. For example, if you want to mix 4 GB and 8 GB memory modules, populate 8 GB memory modules in the sockets with white release tabs and 4 GB memory modules in the sockets with black release tabs.
- In a dual-processor configuration, the memory configuration for each processor should be identical. For example, if you populate socket A1 for processor 1, then populate socket B1 for processor 2, and so on.
- Memory modules of different capacities can be mixed provided other memory population rules are followed (for example, 4 GB and 8 GB memory modules can be mixed).
- Mixing of more than two memory module capacities in a system is not supported.
- Populate four memory modules per processor (one DIMM per channel) at a time to maximize performance.

Related references

[Mode-specific guidelines](#) on page 57

Mode-specific guidelines

Four memory channels are allocated to each processor. The allowable configurations depend on the memory mode selected.

NOTE: You can mix x4 and x8 DRAM based DIMMs to support RAS features. However, all guidelines for specific RAS features must be followed. x4 DRAM based DIMMs retain Single Device Data Correction (SDDC) in memory optimized (independent channel) mode. x8 DRAM based DIMMs need Advanced ECC mode to gain SDDC.

Advanced Error Correction Code (lockstep)

Advanced Error Correction Code (ECC) mode extends SDDC from x4 DRAM based DIMMs to both x4 and x8 DRAMs. This protects against single DRAM chip failures during normal operation.

The installation guidelines for memory modules are as follows:

- Memory modules must be identical in size, speed, and technology.
- DIMMs installed in memory sockets with white release levers must be identical and the same rule applies for sockets with black release levers. This ensures that identical DIMMs are installed in matched pair —for example, A1 with A2, A3 with A4, A5 with A6, and so on.

Memory optimized (independent channel) mode

This mode supports Single Device Data Correction (SDDC) only for memory modules that use x4 device width. It does not impose any specific slot population requirements.

Memory sparing

NOTE: To use memory sparing, this feature must be enabled in System Setup.

In this mode, one rank per channel is reserved as a spare. If persistent correctable errors are detected on a rank, the data from this rank is copied to the spare rank, and the failed rank is disabled.

With memory sparing enabled, the system memory available to the operating system is reduced by one rank per channel. For example, in a dual-processor configuration with sixteen 4 GB single-rank memory modules, the available system memory is: 3/4 (ranks/channel) × 16 (memory modules) × 4 GB = 48 GB, and not 16 (memory modules) × 4 GB = 64 GB.

NOTE: Memory sparing does not offer protection against a multi-bit uncorrectable error.

NOTE: Both Advanced ECC/Lockstep and Optimizer modes support memory sparing.

Memory mirroring

Memory mirroring offers the strongest memory module reliability mode compared to all other modes, providing improved uncorrectable multi-bit failure protection. In a mirrored configuration, the total available system memory is one half of the total installed physical memory. Half of the installed memory is used to mirror the active memory modules. In the event of an uncorrectable error, the system switches over to the mirrored copy. This ensures SDDC and multi-bit protection.

The installation guidelines for memory modules are as follows:

- Memory modules must be identical in size, speed, and technology.
- Memory modules installed in memory module sockets with white release levers must be identical and the same rule applies for sockets with black and green release tabs. This ensures that identical memory modules are installed in matched pairs—for example, A1 with A2, A3 with A4, A5 with A6, and so on.

Table 21. Processor configuration

Processor	Configuration	Memory population rules	Memory population information
Single CPU	Memory population order	{1,2}, {3,4}	See Memory mirroring note

Sample memory configurations

The following tables show sample memory configurations for one and two processor configurations that follow the appropriate memory guidelines.

NOTE: 1R, 2R, and 4R in the following tables indicate single, dual, and quad-rank DIMMs respectively.

Table 22. Memory configurations—single processor

System capacity (in GB)	DIMM size (in GB)	Number of DIMMs	DIMM rank, organization, and frequency	DIMM slot population
4	4	1	1R, x8, 2133 MT/s, 1R, x8, 1866 MT/s	A1
8	4	2	1R, x8, 2133 MT/s, 1R, x8, 1866 MT/s	A1, A2
16	4	4	1R, x8, 2133 MT/s, 1R, x8, 1866 MT/s	A1, A2, A3, A4
	8	2	2R, x8, 2133 MT/s, 2R, x8, 1866 MT/s	A1, A2
24	4	6	1R, x8, 2133 MT/s, 1R, x8, 1866 MT/s	A1, A2, A3, A4, A5, A6
48	4	12	1R, x8, 1866 MT/s 1R, x8, 1600 MT/s	A1, A2, A3, A4, A5, A6, A7, A8, A9, A10, A11, A12

Table 22. Memory configurations—single processor (continued)

System capacity (in GB)	DIMM size (in GB)	Number of DIMMs	DIMM rank, organization, and frequency	DIMM slot population
	8	6	2R, x8, 2133 MT/s, 2R, x8, 1866 MT/s	A1, A2, A3, A4, A5, A6
96	8	12	2R, x8, 1866 MT/s 2R, x8 1600 MT/s	A1, A2, A3, A4, A5, A6, A7, A8, A9, A10, A11, A12
	16	6	2R, x4, 2133 MT/s, 2R, x4, 1866 MT/s	A1, A2, A3, A4, A5, A6
128	16	8	2R, x4, 2133 MT/s, 2R, x4, 1866 MT/s,	A1, A2, A3, A4, A5, A6, A7, A8
144	16 and 8	10	2R, x4 and 2R, x8, 1866 MT/s 2R, x4 and 2R, x8, 1600 MT/s	A1, A2, A3, A4, A5, A6, A7, A8, A9, A11 NOTE: 16 GB DIMMs must be installed in slots numbered A1, A2, A3, A4, A5, A6, A7, and A8. 8 GB DIMMs must be installed in slots A9 and A11.
384	32	12	LRDIMM, x4, 1866 MT/s LRDIMM, x4, 1600 MT/s	A1, A2, A3, A4, A5, A6, A7, A8, A9, A10, A11, A12

Table 23. Memory configurations—two processors

System capacity (in GB)	DIMM size (in GB)	Number of DIMMs	DIMM rank, organization, and frequency	DIMM slot population
16	4	4	1R, x8, 2133 MT/s, 1R, x8, 1866 MT/s	A1, A2, B1, B2
32	4	8	1R, x8, 2133 MT/s, 1R, x8, 1866 MT/s	A1, A2, A3, A4, B1, B2, B3, B4
64	4	16	1R, x8, 2133 MT/s 1R, x8, 1866 MT/s	A1, A2, A3, A4, A5, A6, A7, A8, B1, B2, B3, B4, B5, B6, B7, B8
	8	8	2R, x8, 2133 MT/s, 2R, x8, 1866 MT/s	A1, A2, A3, A4, B1, B2, B3, B4
96	4	24	1R, x8, 1866 MT/s 1R, x8, 1600 MT/s	A1, A2, A3, A4, A5, A6, A7, A8, A9, A10, A11, A12, B1, B2, B3, B4, B5, B6, B7, B8, B9, B10, B11, B12
	8	12	2R, x8, 2133 MT/s, 2R, x8, 1866 MT/s	A1, A2, A3, A4, A5, A6, B1, B2, B3, B4, B5, B6
128	8	16	2R, x8, 2133 MT/s 2R, x8, 1866 MT/s	A1, A2, A3, A4, A5, A6, A7, A8, B1, B2, B3, B4, B5, B6, B7, B8
	16	8	2R, x4, 2133 MT/s, 2R, x4, 1866 MT/s	A1, A2, A3, A4, B1, B2, B3, B4

Table 23. Memory configurations—two processors (continued)

System capacity (in GB)	DIMM size (in GB)	Number of DIMMs	DIMM rank, organization, and frequency	DIMM slot population
160	8	20	2R, x8, 1866 MT/s 2R, x8, 1600 MT/s	A1, A2, A3, A4, A5, A6, A7, A8, A9, A11, B1, B2, B3, B4, B5, B6, B7, B8, B9, B11
	16 and 8	12	2R, x4, 2133 MT/s, 2R, x8, 2133 MT/s, 2R, x4, 1866 MT/s 2R, x8, 1866 MT/s	A1, A2, A3, A4, A5, A6, B1, B2, B3, B4, B5, B6 i NOTE: 16 GB DIMMs must be installed in slots numbered A1, A2, A3, A4, B1, B2, B3, and B4. 8 GB DIMMs must be installed in slots A5, A6, B5, and B6.
192	8	24	2R, x8, 1866 MT/s 2R, x8, 1600 MT/s	A1, A2, A3, A4, A5, A6, A7, A8, A9, A10, A11, A12, B1, B2, B3, B4, B5, B6, B7, B8, B9, B10, B11, B12
	16	12	2R, x4, 2133 MT/s, 2R, x4, 1866 MT/s	A1, A2, A3, A4, A5, A6, B1, B2, B3, B4, B5, B6
256	16	16	2R, x4, 2133 MT/s, 2R, x4, 1866 MT/s,	A1, A2, A3, A4, A5, A6, A7, A8, B1, B2, B3, B4, B5, B6, B7, B8
384	16	24	2R, x4, 1866 MT/s, 2R, x4, 1600 MT/s,	A1, A2, A3, A4, A5, A6, A7, A8, A9, A10, A11, A12, B1, B2, B3, B4, B5, B6, B7, B8, B9, B10, B11, B12
	32	12	LRDIMM, 4R, x4, 2133 MT/s	A1, A2, A3, A4, A5, A6, B1, B2, B3, B4, B5, B6
512	32	16	LRDIMM, 4R, x4, 2133 MT/s	A1, A2, A3, A4, A5, A6, A7, A8, B1, B2, B3, B4, B5, B6, B7, B8
768	32	24	LRDIMM, 4R, x4, 1866 MT/s LRDIMM, 4R, x4, 1600 MT/s	A1, A2, A3, A4, A5, A6, A7, A8, A9, A10, A11, A12, B1, B2, B3, B4, B5, B6, B7, B8, B9, B10, B11, B12

Removing memory modules

Prerequisites

CAUTION: Many repairs may only be done by a certified service technician. You should only perform troubleshooting and simple repairs as authorized in your product documentation, or as directed by the online or telephone service and support team. Damage due to servicing that is not authorized by Dell is not covered by your warranty. Read and follow the safety instructions that are shipped with your product.

1. Follow the safety guidelines listed in the Safety instructions section.
2. Follow the procedure listed in the Before working inside your system section.
3. Remove the cooling shroud.

i **NOTE:** The memory modules are hot to touch for some time after the system has been powered down. Allow the memory modules to cool before handling them. Handle the memory modules by the card edges and avoid touching the components or metallic contacts on the memory module.

CAUTION: To ensure proper system cooling, memory module blanks must be installed in any memory socket that is not occupied. Remove memory module blanks only if you intend to install memory modules in those sockets.

Steps

1. Locate the appropriate memory module socket.

CAUTION: Handle each memory module only by the card edges, ensuring not to touch the middle of the memory module or metallic contacts.

2. To release the memory module from the socket, simultaneously press the ejectors on both ends of the memory module socket.
3. Lift and remove the memory module from the system.

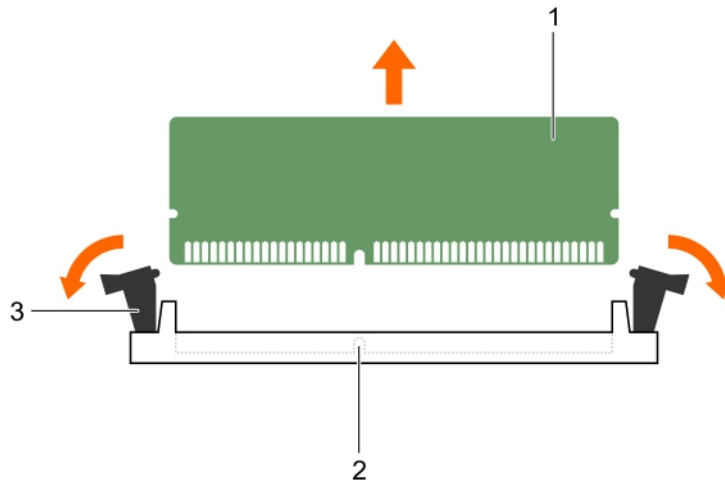

Figure 12. Removing the memory module

- a. memory module
- b. memory module socket
- c. memory module socket ejector (2)

Next steps

1. Install the memory module.
NOTE: If you are removing the memory module permanently, install a memory module blank.
2. Install the cooling shroud.
3. Follow the procedure listed in the After working inside your system section.

Related references

[Safety instructions](#) on page 48

Related tasks

[Before working inside your system](#) on page 49

[After working inside your system](#) on page 49

Installing memory modules

Prerequisites

NOTE: The memory modules are hot to touch for some time after the system has been powered down. Allow the memory modules to cool before handling them. Handle the memory modules by the card edges and avoid touching the components or metallic contacts on the memory module.

CAUTION: Many repairs may only be done by a certified service technician. You should only perform troubleshooting and simple repairs as authorized in your product documentation, or as directed by the online or telephone service and support team. Damage due to servicing that is not authorized by Dell is not covered by your warranty. Read and follow the safety instructions that are shipped with your product.

1. Follow the safety guidelines listed in the Safety instructions section.
2. Follow the procedure listed in the Before working inside your system section.
3. Removing the cooling fan assembly.

Steps

1. Locate the appropriate memory module socket.

CAUTION: Handle each memory module only by the card edges, ensuring not to touch the middle of the memory module or metallic contacts.

2. Open the ejectors on the memory module socket outward to allow the memory module to be inserted into the socket.
3. Align the edge connector of the memory module with the alignment key of the memory module socket, and insert the memory module in the socket.

CAUTION: Do not apply pressure at the center of the memory module; apply pressure at both ends of the memory module evenly.

NOTE: The memory module socket has an alignment key that enables you to install the memory module in the socket in only one orientation.

4. Press the memory module with your thumbs until the socket levers firmly click into place.

When the memory module is properly seated in the socket, the levers on the memory module socket align with the levers on the other sockets that have memory modules installed.

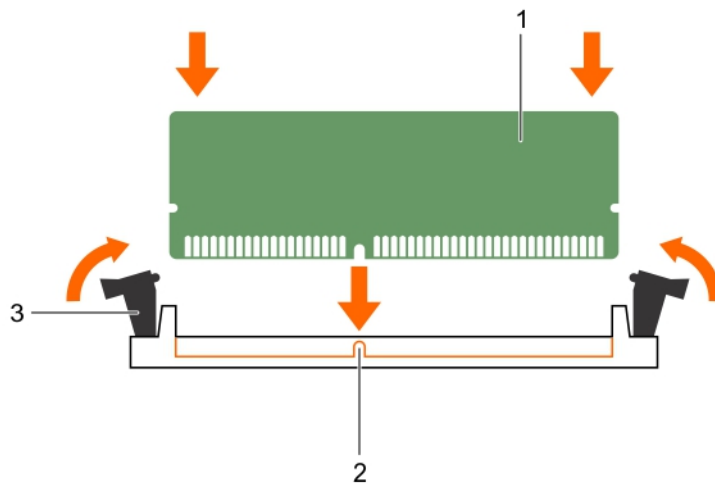

Figure 13. Installing the memory module

- a. memory module
- b. alignment key
- c. memory module socket ejector (2)

Next steps

1. Follow the procedure listed in the After working inside your system section.
2. Press F2 to enter System Setup, and check the **System Memory** setting.

The system should have already changed the value to reflect the installed memory.

3. If the value is incorrect, one or more of the memory modules may not be installed properly. Ensure that the memory module is firmly seated in the memory module socket.
4. Run the system memory test in system diagnostics.

Related references

[Safety instructions](#) on page 48

Related tasks

[Before working inside your system](#) on page 49

[After working inside your system](#) on page 49

Hard disk drives

All HDDs connect to the system board through the HDD backplane. HDDs are supplied in hot-swappable HDD carriers that fit in the HDD slots.

CAUTION: Before attempting to remove or install an HDD while the system is running, see the documentation for the storage controller card to ensure that the host adapter is configured correctly to support hot-swappable HDD removal and insertion.

CAUTION: Do not turn off or restart your system while the HDD is being formatted. Doing so can cause a HDD failure.

NOTE: Use only HDDs that have been tested and approved for use with the HDD backplane.

When you format an HDD, allow enough time for the formatting to be completed. Be aware that high-capacity HDDs can take a number of hours to format.

Removing 2.5 inch HDD blank

Prerequisites

CAUTION: Many repairs may only be done by a certified service technician. You should only perform troubleshooting and simple repairs as authorized in your product documentation, or as directed by the online or telephone service and support team. Damage due to servicing that is not authorized by Dell is not covered by your warranty. Read and follow the safety instructions that came with the product.

CAUTION: To maintain proper system cooling, all empty HDD slots must have HDD blanks installed.

1. Ensure that you read the Safety instructions section in this document.
2. If installed, remove the bezel.

Steps

Press the release button and slide the HDD blank out of the HDD slot.

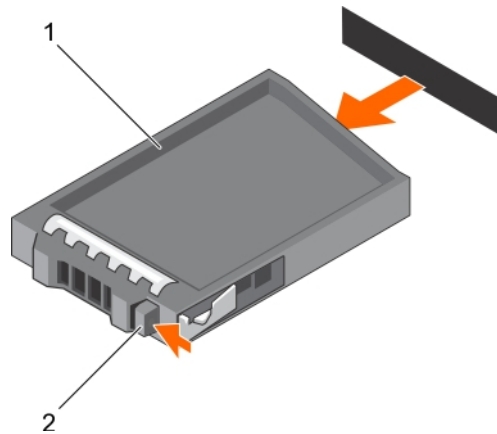

Figure 14. Removing and installing a 2.5 inch HDD blank

- a. HDD blank
- b. release button

Related references

[Safety instructions](#) on page 48

Installing 2.5 inch HDD blank

Prerequisites

1. Ensure that you read the Safety instructions section in this document.
2. If installed, remove the front bezel.

Steps

Insert the HDD blank into the HDD slot until the release button clicks into place.

Next steps

If applicable, install the front bezel.

Related references

[Safety instructions](#) on page 48

Removing hot-swappable HDD

Prerequisites

CAUTION: Many repairs may only be done by a certified service technician. You should only perform troubleshooting and simple repairs as authorized in your product documentation, or as directed by the online or telephone service and support team. Damage due to servicing that is not authorized by Dell is not covered by your warranty. Read and follow the safety instructions that came with the product.

1. Ensure that you read the Safety instructions section in this document.
2. If applicable, remove the bezel.
3. Using the management software, prepare the HDD for removal. Wait until the indicators on the HDD carrier signal that the HDD can be removed safely. For more information, see the documentation for the storage controller.

If the HDD is online, the green activity/fault indicator flashes as the drive is turned off. When the HDD indicators are turned off, the HDD is ready for removal.

CAUTION: To prevent data loss, ensure that your operating system supports hot-swap drive installation. See the documentation supplied with your operating system.

Steps

1. Press the release button to open the HDD carrier release handle.
2. Slide the HDD carrier out of the HDD slot.

CAUTION: To maintain proper system cooling, all empty HDD slots must have HDD blanks installed.

3. If you are not replacing the HDD immediately, insert an HDD blank in the empty HDD slot.

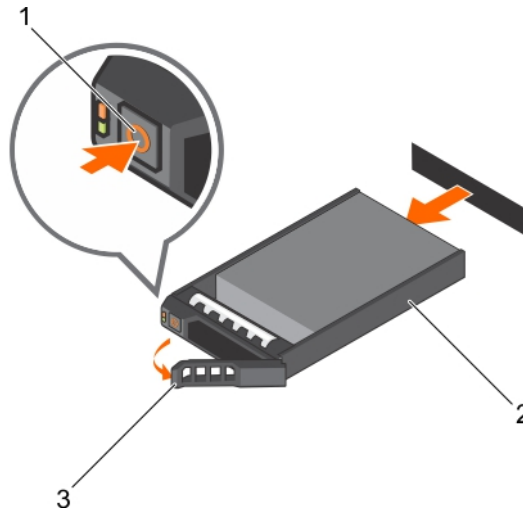

Figure 15. Removing and installing a hot-swappable HDD

- a. release button
- b. HDD carrier
- c. HDD carrier handle

Related references

[Safety instructions](#) on page 48

Installing hot-swappable HDD

Prerequisites

CAUTION: Many repairs may only be done by a certified service technician. You should only perform troubleshooting and simple repairs as authorized in your product documentation, or as directed by the online or telephone service and support team. Damage due to servicing that is not authorized by Dell is not covered by your warranty. Read and follow the safety instructions that are shipped with your product.

1. Ensure that you read the Safety instructions section in this document.

CAUTION: Use only HDDs that have been tested and approved for use with the HDD backplane.

CAUTION: Combining SAS and SATA HDDs in the same RAID volume is not supported.

CAUTION: When installing a HDD, ensure that the adjacent drives are fully installed. Inserting a HDD carrier and attempting to lock its handle next to a partially installed carrier can damage the partially installed carrier's shield spring and make it unusable.

CAUTION: To prevent data loss, ensure that your OS supports hot-swap drive installation. See the documentation supplied with your operating system.

CAUTION: When a replacement hot-swappable HDD is installed and the system is powered on, the HDD automatically begins to rebuild. Make absolutely sure that the replacement HDD is blank or contains data that you wish to have over-written. Any data on the replacement HDD is immediately lost after the HDD is installed.

Steps

1. If an HDD blank is installed in the HDD slot, remove it.
2. Install an HDD in the HDD carrier. For more information, see the Installing an HDD into an HDD carrier section in this document.
3. Press the release button on the front of the HDD carrier and open the HDD carrier handle.
4. Insert the HDD carrier into the HDD slot until the carrier connects with the backplane.
5. Close the HDD carrier handle to lock the HDD in place.

Next steps

Install the optional front bezel.

Related references

[Safety instructions](#) on page 48

Related tasks

[Installing HDD into HDD carrier](#) on page 67

Removing HDD from HDD carrier

Prerequisites

1. Keep the #1 Phillips screwdriver handy.
2. Remove the HDD carrier from the system.

Steps

1. Remove the screws from the slide rails on the HDD carrier.
2. Lift the HDD out of the HDD carrier.

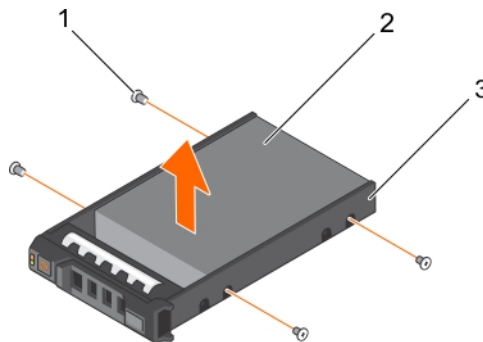



Figure 16. Removing and installing a HDD into a HDD carrier

- a. screw (4)
- b. HDD
- c. HDD carrier

Installing HDD into HDD carrier

Prerequisites

 **CAUTION:** Many repairs may only be done by a certified service technician. You should only perform troubleshooting and simple repairs as authorized in your product documentation, or as directed by the online or telephone service and support team. Damage due to servicing that is not authorized by Dell is not covered by your warranty. Read and follow the safety instructions that are shipped with your product.

Keep the #1 Phillips screwdriver handy.

Steps

1. Insert the HDD into the HDD carrier with the connector end of the HDD toward the back.
2. Align the screw holes on the HDD with the set of screw holes on the HDD carrier.
When aligned correctly, the back of the HDD is flush with the back of the HDD carrier.
3. Attach the screws to secure the HDD to the HDD carrier.

Optical drive (optional)

Optical drives retrieve and store data on optical discs such as CD and DVD. Optical drives can be categorized into two basic types: optical disc readers and optical disc writers.

Removing optical drive

Prerequisites

1. Ensure that you read the Safety instructions section in this document.
2. Follow the procedure listed in the Before working inside your system section in this document.

 **CAUTION:** Many repairs may only be done by a certified service technician. You should only perform troubleshooting and simple repairs as authorized in your product documentation, or as directed by the online or telephone service and support team. Damage due to servicing that is not authorized by Dell is not covered by your warranty. Read and follow the safety instructions that are shipped with your product.

Steps

1. Disconnect the power/data cable from the back of the drive.
Note the routing of the power/data cable on the side of the system as you remove them from the system board and drive. Route these cables properly when you replace them to prevent them from being pinched or crimped.
2. To release the optical drive, press the release tab.
3. Slide the optical drive out of the system until it is free of the optical-drive slot.
4. If you are not adding a new optical drive, install the optical drive blank.

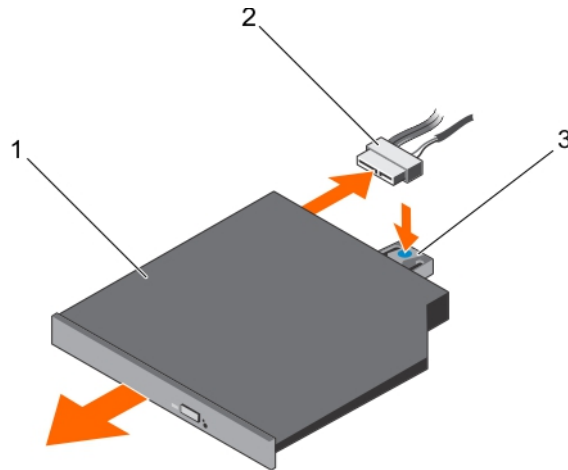

Figure 17. Removing and installing optical drive

- a. Optical drive
- b. Power and data cable
- c. Release tab

Next steps

Follow the procedure listed in the After working inside your system section in this document.

Related references

[Safety instructions](#) on page 48

Related tasks

[Before working inside your system](#) on page 49

[After working inside your system](#) on page 49

Installing the optical drive

Prerequisites

CAUTION: Many repairs may only be done by a certified service technician. You should only perform troubleshooting and simple repairs as authorized in your product documentation, or as directed by the online or telephone service and support team. Damage due to servicing that is not authorized by Dell is not covered by your warranty. Read and follow the safety instructions that are shipped with your product.

1. Follow the safety guidelines listed in the Safety instructions section.
2. Follow the procedure listed in the Before working inside your system section.
3. If installed, remove the optical drive blank.

Steps

1. Align the optical drive with the optical drive slot on the front of the chassis.
2. Slide in the optical drive until the release tab snaps into place.
3. Connect the power and data cable to the optical drive and system board.

NOTE: Route the cable properly on the side of the system to prevent it from being pinched or crimped.

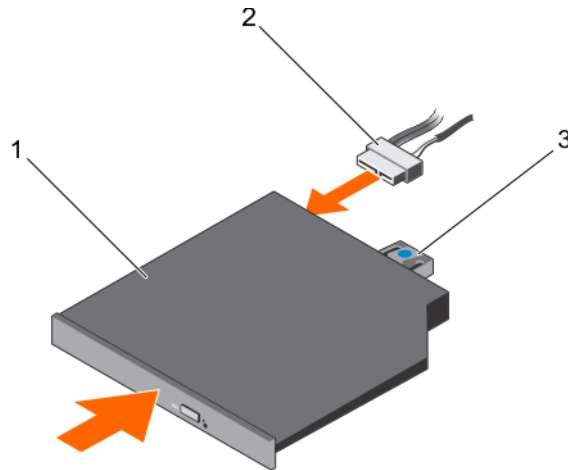

Figure 18. Installing the optional optical drive

- a. optical drive
- b. power and data cable
- c. release tab

Next steps

Follow the procedure listed in the After working inside your system section.

Related references

[Safety instructions](#) on page 48

Related tasks

[Before working inside your system](#) on page 49

[After working inside your system](#) on page 49

Removing the slim optical drive blank

Prerequisites

CAUTION: Many repairs may only be done by a certified service technician. You should only perform troubleshooting and simple repairs as authorized in your product documentation, or as directed by the online or telephone service and support team. Damage due to servicing that is not authorized by Dell is not covered by your warranty. Read and follow the safety instructions that are shipped with your product.

1. Follow the safety guidelines listed in the Safety instructions section.
2. Follow the procedure listed in the Before working inside your system section.

Steps

1. Locate the touch point for the slim optical drive blank lock inside the system.
2. Press the lock and pull the slim optical drive blank out of the chassis.

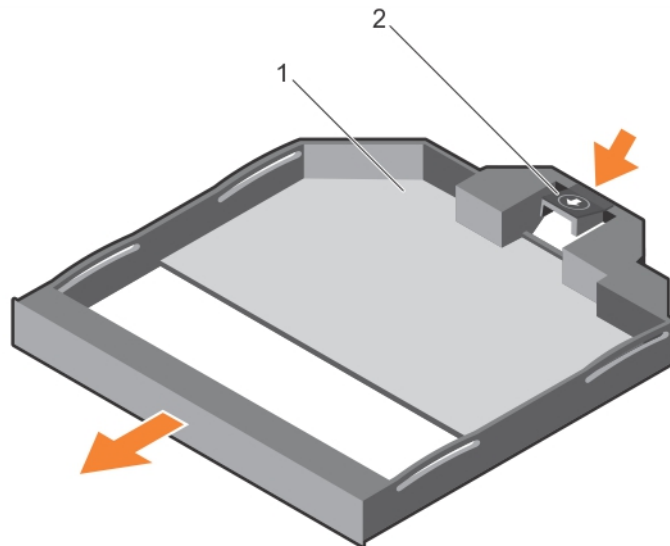

Figure 19. Removing the slim optical drive blank

- a. slim optical drive blank
- b. optical drive blank lock

Related references

[Safety instructions](#) on page 48

Related tasks

[Before working inside your system](#) on page 49

Installing the slim optical drive blank

Prerequisites

CAUTION: Many repairs may only be done by a certified service technician. You should only perform troubleshooting and simple repairs as authorized in your product documentation, or as directed by the online or telephone service and support team. Damage due to servicing that is not authorized by Dell is not covered by your warranty. Read and follow the safety instructions that are shipped with your product.

1. Follow the safety instructions listed in the Safety instructions section.
2. Follow the procedure listed in the Before working inside your system section.

Steps

1. Align the slim optical drive blank with the slim optical drive bay.
2. Slide the optical drive blank into the optical drive bay until the lock clicks into place.

Next steps

Follow the procedure listed in the After working inside your system section.

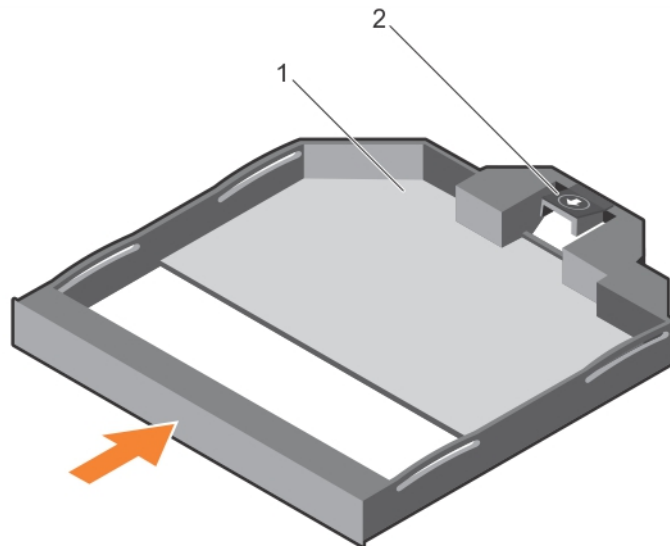

Figure 20. Installing the slim optical drive blank

1. slim optical drive blank
2. optical drive blank lock

Related references

[Safety instructions](#) on page 48

Related tasks

[After working inside your system](#) on page 49

Cooling fans

Your system supports hot-swappable cooling fans.

NOTE: In the event of a issue with a particular fan, the fan number is referenced by the system management software, allowing you to easily identify and replace the proper fan by noting the fan numbers on the cooling-fan assembly.

Removing cooling fan

Prerequisites

1. Ensure that you read the Safety instructions section in this document.
2. Follow the procedure listed in the Before working inside your system section in this document.

NOTE: Opening or removing the system cover when the system is ON may expose you to a risk of electric shock. Exercise utmost care while removing or installing cooling fans.

CAUTION: Many repairs may only be done by a certified service technician. You should only perform troubleshooting and simple repairs as authorized in your product documentation, or as directed by the online or telephone service and support team. Damage due to servicing that is not authorized by Dell is not covered by your warranty. Read and follow the safety instructions that are shipped with your product.

CAUTION: The cooling fans are hot-swappable. To maintain proper cooling while the system is on, replace only one fan at a time.

CAUTION: Do not operate the system with the cover removed for a duration exceeding five minutes.

NOTE: The procedure for removing each fan is identical.

Steps

Hold the fan and lift it out of the system.

Next steps

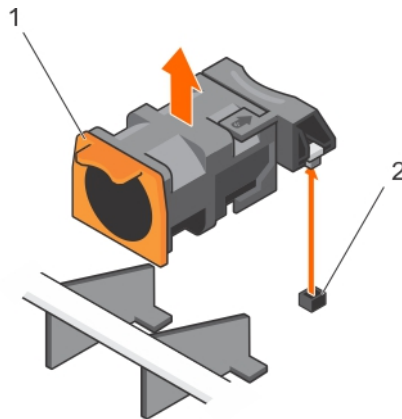

Figure 21. Removing and installing a cooling fan

1. cooling fans (7)
2. cooling fan connectors (7)

Related references

[Safety instructions](#) on page 48

Related tasks

[Before working inside your system](#) on page 49

Installing cooling fan

Prerequisites

1. Ensure that you read the Safety instructions section in this document.
2. Follow the procedure listed in the Before working inside your system section in this document.

CAUTION: Many repairs may only be done by a certified service technician. You should only perform troubleshooting and simple repairs as authorized in your product documentation, or as directed by the online or telephone service and support team. Damage due to servicing that is not authorized by Dell is not covered by your warranty. Read and follow the safety instructions that are shipped with your product.

NOTE: Your system supports seven hot-swappable cooling fans.

Steps

1. Align the plug at the base of the cooling fan with the connector on the system board.
2. Slide the cooling fan into the securing slots until the tabs lock into place.

Next steps

Follow the procedure listed in the After working inside your system section in this document.

Related references

[Safety instructions](#) on page 48

Related tasks

[Before working inside your system](#) on page 49

Expansion cards and expansion card riser

An expansion card in the server is an add-on card that can be inserted into an expansion slot on the system board or riser card to add enhanced functionality to the system through the expansion bus.

NOTE: A System Event Log (SEL) event is logged if an expansion card riser is unsupported or missing. It does not prevent your system from turning on and no BIOS POST message or F1/F2 pause is displayed.

Expansion card installation guidelines

Your system supports PCI Express Generation 3 expansion cards.

Table 24. Systems supporting three PCIe expansion cards

Riser	PCIe Slot	Processor Connection	Height	Length	Link Width	Slot Width
1	1	Processor 2	Low Profile	Half Length	x16	x16
1	2	Processor 2	Low Profile	Half Length	x8	x16
3	3	Processor 1	Low Profile	Half Length	x16	x16

NOTE: Both the processors must be installed to use riser 1 slots.

NOTE: For a server with three PCIe cards, only MiniSAS HD third party cards are supported in slot 3. For a server with two PCIe cards, only MiniSAS HD third-party cards are supported in slot 1.

NOTE: You can install expansion cards only on one slot on riser 2.

NOTE: Both the processors must be installed to use the x16 link on the riser 2 slot.

The following table provides a guide for installing expansion cards to ensure proper cooling and mechanical fit. The expansion cards with the highest priority must be installed first using the slot priority indicated. All other expansion cards must be installed in the specified card priority and slot priority order.

NOTE: Use the "Systems Support up to 3 PCIe Expansion Cards" column for installation on the Dell Storage NX3330 system.

Table 25. Expansion-card installation priority

Card Priority	Card Type	Systems Supporting up to 2 PCIe Expansion Cards		Systems Supporting up to 3 PCIe Expansion Cards	
		Slot Priority	Max Allowed	Slot Priority	Max Allowed
1	PCIe Bridge	N/A	N/A	1	1
2	RAID	1	1	3, 1	2
3	40 G NICs	2, 1	1	3,2	1
4	10 Gb NICs	2, 1	2	3, 2, 1	3
5	FC16 HBA	2, 1	1	3, 2, 1	1
6	FC8 HBA	2, 1	1	3, 2, 1	3
7	FC4 HBA	2, 1	1	3, 2, 1	3
8	FC16 HBA	2,1	1	N/A	N/A
9	1 Gb NICs	2, 1	1	3, 2, 1	3
10	Non-RAID	2	1	N/A	N/A
11	Integrated RAID	Integrated Slot	1	Integrated Slot	1

Table 25. Expansion-card installation priority (continued)

Card Priority	Card Type	Systems Supporting up to 2 PCIe Expansion Cards		Systems Supporting up to 3 PCIe Expansion Cards	
		Slot Priority	Max Allowed	Slot Priority	Max Allowed
12	NDC	Integrated Slot	1	Integrated Slot	1

Removing expansion card

Prerequisites

1. Ensure that you read the Safety instructions section in this document.
2. Follow the procedure listed in the Before working inside your system section in this document.

CAUTION: Many repairs may only be done by a certified service technician. You should only perform troubleshooting and simple repairs as authorized in your product documentation, or as directed by the online or telephone service and support team. Damage due to servicing that is not authorized by Dell is not covered by your warranty. Read and follow the safety instructions that are shipped with your product.

Steps

1. Disconnect any cables connected to the expansion card or expansion card riser.
2. To remove the expansion card, lift the expansion-card latch.
3. Grasp the expansion card by its edges and remove it from the expansion-card connector on the riser.
4. If you are removing the card permanently, install a metal filler bracket over the empty expansion slot opening and close the expansion-card latch.

NOTE: You must install a filler bracket over an empty expansion card slot to maintain Federal Communications Commission (FCC) certification of the system. The brackets also keep dust and dirt out of the system and aid in proper cooling and airflow inside the system.

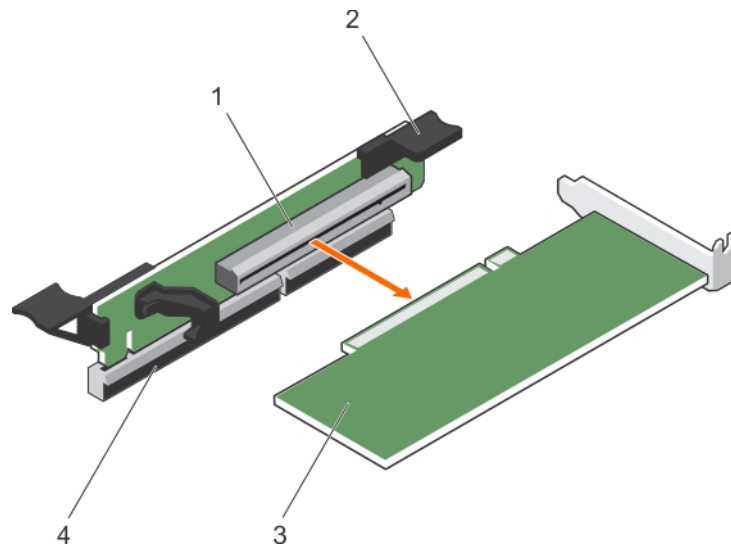

Figure 22. Removing and installing the expansion card

1. expansion connector
2. expansion card latch
3. expansion-card
4. expansion-card latch

Next steps

Follow the procedure listed in the After working inside your system section in this document.

Related references

[Safety instructions](#) on page 48

Related tasks

[Before working inside your system](#) on page 49

[After working inside your system](#) on page 49

Installing expansion card

Prerequisites

1. Ensure that you read the Safety instructions section in this document.
2. Follow the procedure listed in the Before working inside your system section in this document.

 **CAUTION:** Many repairs may only be done by a certified service technician. You should only perform troubleshooting and simple repairs as authorized in your product documentation, or as directed by the online or telephone service and support team. Damage due to servicing that is not authorized by Dell is not covered by your warranty. Read and follow the safety instructions that are shipped with your product.

 **NOTE:** The expansion-card riser 1 and the x16 link on the riser 2 slot can be used only when both the processors are installed.

Steps

1. Unpack the expansion card and prepare it for installation.
For instructions, see the documentation accompanying the card.
2. Locate the expansion-card connector on the system board/riser.
3. Open the expansion-card latch and remove the filler bracket.
4. Holding the card by its edges, position the card so that the card-edge connector aligns with the expansion-card connector.
5. Insert the card-edge connector firmly into the expansion-card connector until the card is fully seated.
6. Slide the expansion-card latch into position.

Next steps

1. Follow the procedure listed in the After working inside your system section in this document.
2. Install any device drivers required for the card as described in the documentation for the card.

Related references

[Safety instructions](#) on page 48

Related tasks

[Before working inside your system](#) on page 49

[After working inside your system](#) on page 49

Removing expansion-card risers

Prerequisites

1. Ensure that you read the Safety instructions section in this document.
2. Follow the procedure listed in the Before working inside your system section in this document.

 **CAUTION:** Many repairs may only be done by a certified service technician. You should only perform troubleshooting and simple repairs as authorized in your product documentation, or as directed by the online or telephone service and support team. Damage due to servicing that is not authorized by Dell is not covered by your warranty. Read and follow the safety instructions that are shipped with your product.

NOTE: The expansion-card riser 1 and the x16 link on the riser 2 slot can be used only when both the processors are installed.

Steps

1. Holding the touch points, lift the expansion-card riser from the riser connector on the system board.

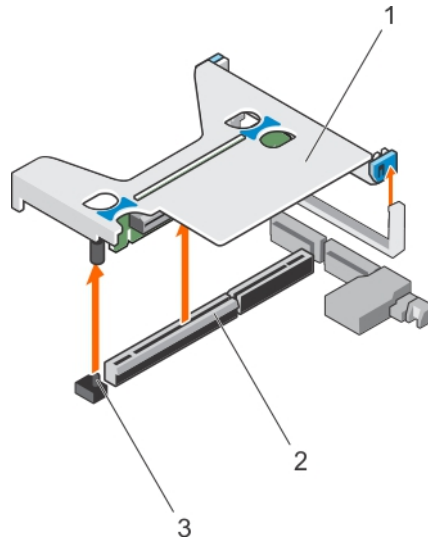

Figure 23. Removing and installing the expansion card riser 1

- a. expansion-card riser 1
- b. connector
- c. riser guide pin

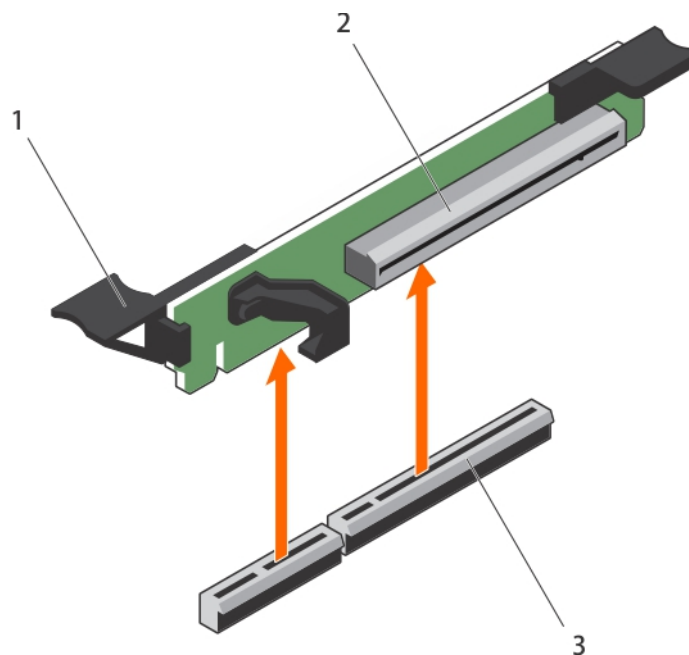

Figure 24. Removing and installing the expansion card riser 3

- a. connector
- b. expansion card riser 3
- c. expansion card release latch

2. If applicable, remove or install an expansion card on the riser.
3. Replace the expansion-card riser.

Next steps

Follow the procedure listed in the After working inside your system section in this document.

Related references

[Safety instructions](#) on page 48

Related tasks

[Before working inside your system](#) on page 49

[After working inside your system](#) on page 49

Installing expansion card risers

Prerequisites

 **CAUTION: Many repairs may only be done by a certified service technician. You should only perform troubleshooting and simple repairs as authorized in your product documentation, or as directed by the online or telephone service and support team. Damage due to servicing that is not authorized by Dell is not covered by your warranty. Read and follow the safety instructions that are shipped with your product.**

Steps

1. If applicable, reinstall the expansion card(s) into the expansion card riser.
2. Align the expansion-card riser with the connector and the riser guide pin on the system board.
3. Lower the expansion-card riser into place until the expansion-card riser connector is fully seated in the connector.

Next steps

1. Follow the procedure listed in the After working inside your system section in this document.
2. Install any device drivers required for the card as described in the documentation for the card.

Related tasks

[After working inside your system](#) on page 49

SD vFlash card (optional)

An SD vFlash card is a Secure Digital (SD) card that plugs into the SD vFlash card slot in the iDRAC port card. It provides persistent on-demand local storage and a custom deployment environment that enables automation of server configuration, scripts, and imaging. It emulates USB device(s). For more information, see the Integrated Dell Remote Access Controller User's Guide at Dell.com/idracmanuals.

Removing the optional SD vFlash card

Prerequisites

1. Follow the safety guidelines listed in the Safety instructions section.
2. Locate the SD vFlash card slot at the back of the chassis.

Steps

To remove the SD vFlash card, push the SD vFlash card inward to release it, and pull the SD vFlash card from the SD vFlash card slot.

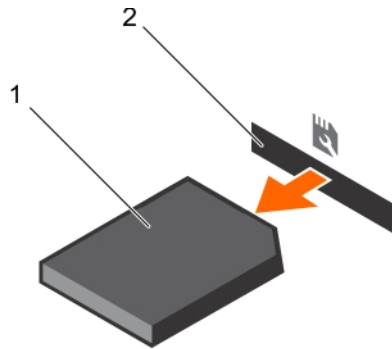

Figure 25. Removing the optional SD vFlash card

- a. SD vFlash card
- b. SD vFlash card slot

Related references

[Safety instructions](#) on page 48

Integrated storage controller card

Your system includes a dedicated expansion card slot on the system board for an integrated controller card. The integrated storage controller card provides the integrated storage subsystem for your system's internal HDDs. The controller supports SAS, and SATA HDDs and also enables you to set up the HDDs in RAID configurations as supported by the version of the storage controller included with your system.

Removing integrated storage controller card

Prerequisites

1. Ensure that you read the Safety instructions section in this document.
2. Complete the tasks listed in the Before working inside your system section in this document.
3. Remove the cooling shroud.
4. Remove the expansion-card riser 1.
5. Keep the #2 Phillips screwdriver handy.

CAUTION: Many repairs may only be done by a certified service technician. You should only perform troubleshooting and simple repairs as authorized in your product documentation, or as directed by the online or telephone service and support team. Damage due to servicing that is not authorized by Dell is not covered by your warranty. Read and follow the safety instructions that are shipped with your product.

Steps

1. Loosen the screws that secure the integrated storage controller cable to the integrated storage-controller card connector on the system board.
2. Lift the integrated storage controller cable out.
3. Lift one end of the card and angle it to disengage the card from the integrated storage-controller card holder on system board.
4. Lift the card out of the chassis.

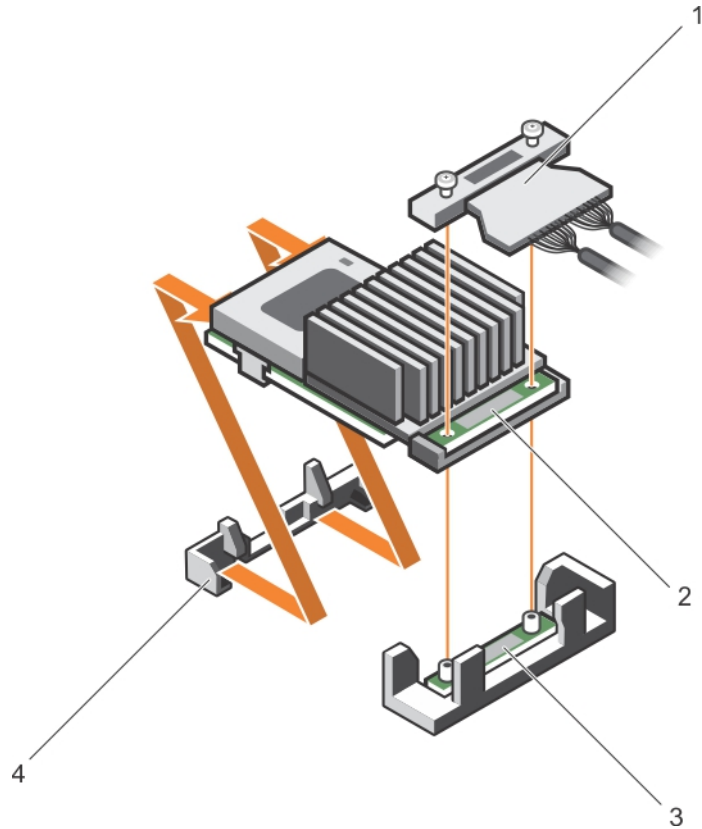

Figure 26. Removing and installing the integrated storage controller card

- | | |
|---|--|
| 1. integrated storage controller cable | 2. integrated storage controller card |
| 3. integrated storage-controller card connector on the system board | 4. integrated storage controller card holder |

Next steps

1. Replace the expansion-card riser 1.
2. Replace the cooling shroud.
3. Complete the tasks listed in the After working inside your system section in this document.

Related references

[Safety instructions](#) on page 48

Related tasks

[Before working inside your system](#) on page 49

[After working inside your system](#) on page 49

Installing integrated storage controller card

Prerequisites

1. Ensure that you read the Safety instructions section in this document.
2. Complete the tasks listed in the Before working inside your system section in this document.
3. Remove the cooling shroud.
4. Remove the expansion card riser 1.
5. Keep the #2 Phillips screwdriver handy.

CAUTION: Many repairs may only be done by a certified service technician. You should only perform troubleshooting and simple repairs as authorized in your product documentation, or as directed by the online or telephone service and support team. Damage due to servicing that is not authorized by Dell is not covered by your warranty. Read and follow the safety instructions that are shipped with your product.

Steps

1. Align the end of the integrated storage-controller card opposite the connector with the integrated storage-controller card holder.
2. Lower the connector side of the integrated storage-controller card into the integrated storage-controller card connector on the system board.
Ensure that the tabs on the system board align with the screw holes on the integrated storage-controller card.
3. Align the screws on the integrated storage-controller card cable with the screw holes on the connector.
4. Tighten the screws to secure the integrated storage-controller card cable with the integrated storage-controller card connector on the system board.

Next steps

1. Replace the expansion card riser 1.
2. Replace the cooling shroud.
3. Complete the tasks listed in the After working inside your system section in this document.

Related references

[Safety instructions](#) on page 48

Related tasks

[Before working inside your system](#) on page 49

[After working inside your system](#) on page 49

Network daughter card

The Network daughter card (NDC) is a small, removable mezzanine card. The NDC provides you with the flexibility of choosing different network connectivity options, for example—4 x 1GbE, 2 x 10GbE and 2 x Converged Network Adapter.

CAUTION: If the GPU card is installed, you cannot install the 10 GbE NDC.

Removing NDC

Prerequisites

1. Ensure that you read the Safety instructions section in this document.
2. Complete the tasks listed in the Before working inside your system section in this document.
3. Keep the #2 Phillips screwdriver handy.

CAUTION: Many repairs may only be done by a certified service technician. You should only perform troubleshooting and simple repairs as authorized in your product documentation, or as directed by the online or telephone service and support team. Damage due to servicing that is not authorized by Dell is not covered by your warranty. Read and follow the safety instructions that are shipped with your product.

Steps

1. Remove the expansion card riser 3.
2. Using a #2 Phillips screwdriver, loosen the two captive screws that secure the NDC to the system board.
3. Hold the NDC by the edges on either side of the touch points and lift to remove it from the connector on the system board.
4. Slide the NDC away from the back of the system until the Ethernet connectors are clear of the slot in the back panel.
5. Lift the NDC out of the system.

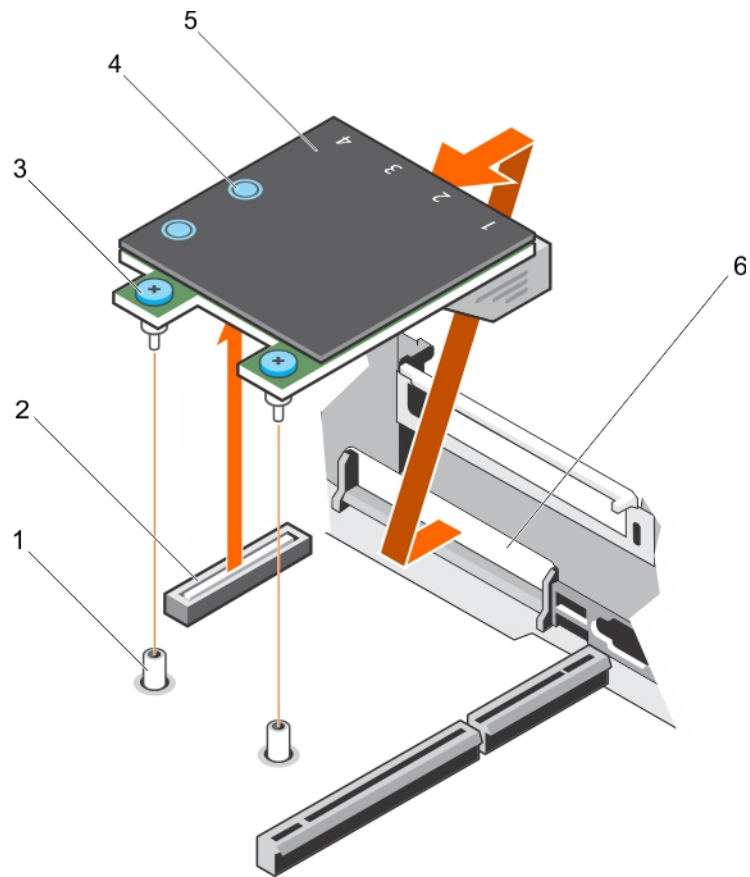

Figure 27. Removing and installing the NDC

- | | |
|---|---|
| <ul style="list-style-type: none"> 1. captive screw socket (2) 3. captive screw (2) 5. NDC | <ul style="list-style-type: none"> 2. connector on the system board 4. touch point (2) 6. back panel slots for Ethernet connectors |
|---|---|

Related references

[Safety instructions](#) on page 48

Related tasks

[Before working inside your system](#) on page 49

Installing the network daughter card

Prerequisites

1. Follow the safety guidelines listed in the Safety instructions section.
2. Follow the procedure listed in the Before working inside your system section.
3. If applicable, remove the expansion card riser 1.
4. Keep the Phillips #1 screwdriver ready.

CAUTION: Many repairs may only be done by a certified service technician. You should only perform troubleshooting and simple repairs as authorized in your product documentation, or as directed by the online or telephone service and support team. Damage due to servicing that is not authorized by Dell is not covered by your warranty. Read and follow the safety instructions that are shipped with your product.

Steps

1. Orient the network daughter card (NDC) so that the Ethernet connectors fit through the slot in the back panel.

2. Align the captive screws on the card with the captive screw sockets on the system board.
3. Press the touch points on the card until the card connector is firmly seated on the system board connector.
4. Tighten the captive screws to secure the NDC to the system board.

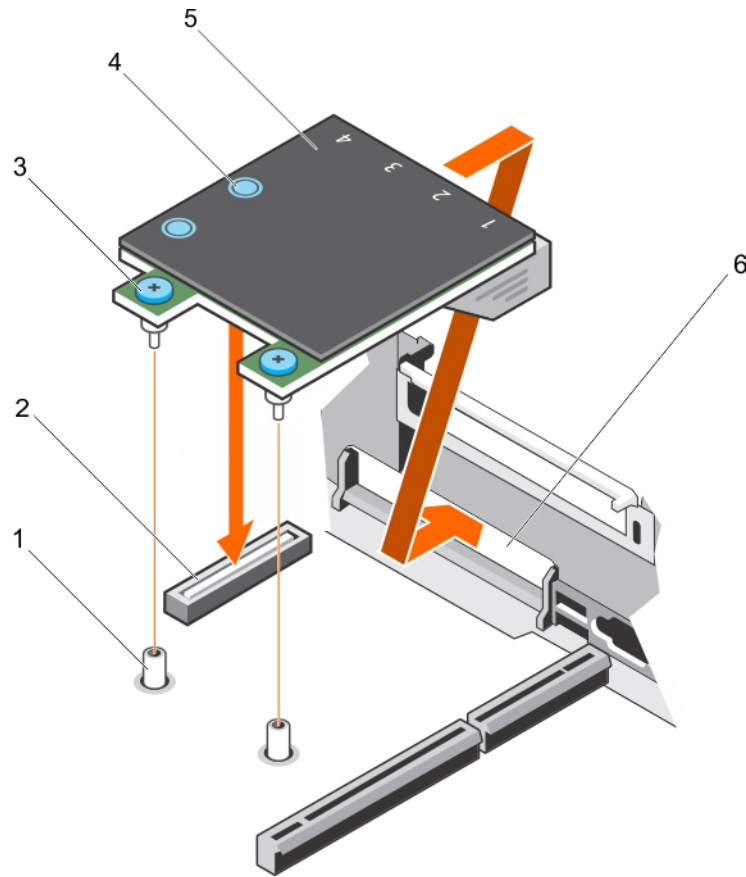

Figure 28. Installing the NDC

- | | |
|--------------------------------|--|
| 1. captive screw socket (2) | 2. connector on the system board |
| 3. captive screw (2) | 4. touch point (2) |
| 5. network daughter card (NDC) | 6. back panel slot for Ethernet connectors |

Next steps

1. If applicable, install the expansion card(s) in the expansion card riser 2.
2. Follow the procedure listed in the After working inside your system section.

Related references

[Safety instructions](#) on page 48

Related tasks

[Before working inside your system](#) on page 49

[After working inside your system](#) on page 49

Processors and heat sinks

Use the following procedures when:

- Removing and installing a heat sink
- Installing an additional processor
- Replacing a processor

 **NOTE:** To ensure proper system cooling, you must install a processor blank in any empty processor socket.

Removing a processor

Prerequisites

 **CAUTION:** Many repairs may only be done by a certified service technician. You should only perform troubleshooting and simple repairs as authorized in your product documentation, or as directed by the online or telephone service and support team. Damage due to servicing that is not authorized by Dell is not covered by your warranty. Read and follow the safety instructions that are shipped with your product.

 **NOTE:** This is a Field Replaceable Unit (FRU). Removal and installation procedures should be performed only by Dell certified service technicians.

 **NOTE:** If you are upgrading your system, download the latest system BIOS version from **Dell.com/support** and follow the instructions included in the compressed download file to install the update on your system.

 **NOTE:** You can update the system BIOS by using the Dell Lifecycle Controller.



 **NOTE:** To ensure proper system cooling, you must install a processor blank in any empty processor socket.

1. Follow the safety guidelines listed in the Safety instructions section.
2. Follow the procedure listed in the Before working inside your system section.
3. Keep the Phillips #2 screwdriver ready.
4. If installed, remove the full-length PCIe card(s).
5. Remove the cooling shroud.
6. Remove the heat sink.

 **WARNING:** The processor is hot to touch for some time after the system has been powered down. Allow the processor to cool before removing it.

 **CAUTION:** The processor is held in its socket under strong pressure. Be aware that the release lever can spring up suddenly if not firmly grasped.

Steps

1. Release the *open first* socket lever near the unlock icon  by pushing the lever down and out from under the tab.
2. Release the *close first* socket release lever near the lock icon  by pushing the lever down and out from under the tab. Lift the lever 90 degrees upward.
3. Lower the *open first* socket-release lever to lift the processor shield.
4. Hold the tab on the processor shield and lift the processor shield until the *open first* socket-release lever lifts up.

 **CAUTION:** The socket pins are fragile and can be permanently damaged. Be careful not to bend the pins in the socket when removing the processor out of the socket.

5. Lift the processor out of the socket and leave the *open first* socket-release lever up.

 **NOTE:** If you are permanently removing the processor, you must install a socket protective cap in the vacant socket to protect the socket pins and keep the socket free of dust.

 **NOTE:** After removing the processor, place it in an anti-static container for reuse, return, or temporary storage. Do not touch the bottom of the processor. Touch only the side edges of the processor.

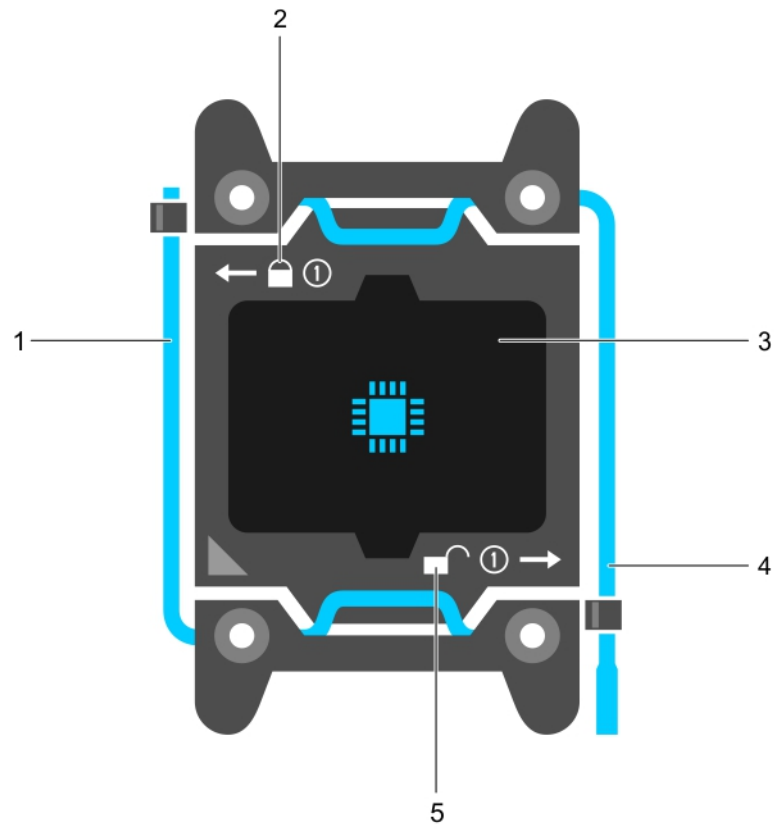

Figure 29. Processor shield

- 1. *close first* socket release lever
- 2. lock icon
- 3. processor
- 4. *open first* socket release lever
- 5. unlock icon

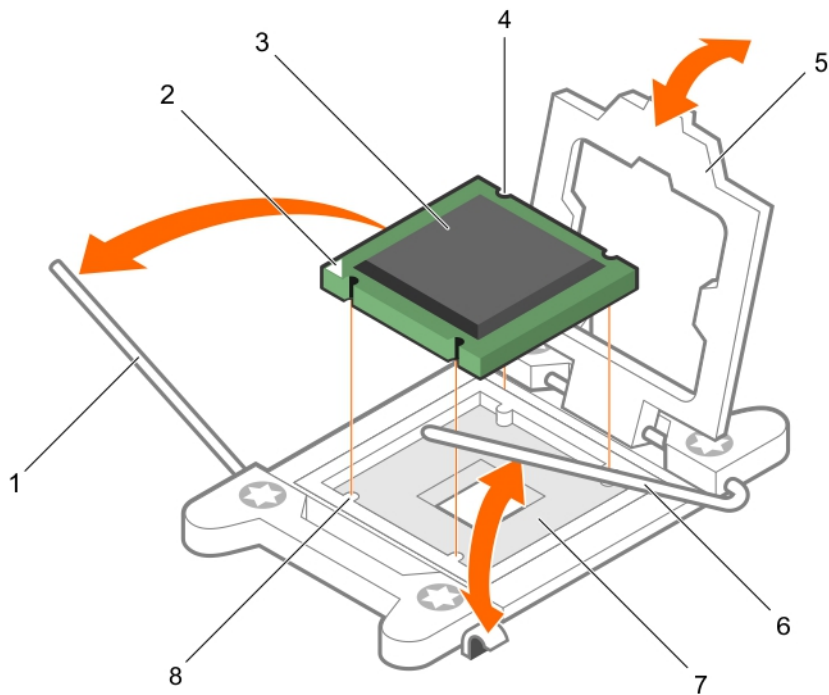

Figure 30. Removing a processor

- | | |
|--|---|
| 1. <i>close first</i> socket-release lever | 2. pin-1 indicator of processor |
| 3. processor | 4. slot (4) |
| 5. processor shield | 6. <i>open first</i> socket-release lever |
| 7. socket | 8. socket keys (4) |

Next steps

1. Replace the processor(s).
2. Install the heat sink.
3. Reinstall the cooling shroud.
4. Follow the procedure listed in the After working inside your system section.

Related references

[Safety instructions](#) on page 48

Related tasks





[Before working inside your system](#) on page 49

[After working inside your system](#) on page 49









Installing a processor

Prerequisites

CAUTION: Many repairs may only be done by a certified service technician. You should only perform troubleshooting and simple repairs as authorized in your product documentation, or as directed by the online or telephone service and support team. Damage due to servicing that is not authorized by Dell is not covered by your warranty. Read and follow the safety instructions that are shipped with your product.

1. Follow the safety guidelines listed in the Safety instructions section.
 2. Follow the procedure listed in the Before working inside your system section.
 3. Keep the Phillips #2 screwdriver ready.
 4. If you are upgrading your system, download the latest system BIOS version from **Dell.com/support** and follow the instructions included in the compressed download file to install the update on your system.
 -  **NOTE:** You can also update the system BIOS by using the Dell Lifecycle Controller.
 5. Remove the cooling shroud.
 -  **NOTE:** If applicable, close the expansion card latch on the cooling shroud to release the full length card.
 6. If connected, disconnect the cables from expansion card(s).
 7. If installed, remove the expansion card riser.
 -  **NOTE:** The heat sink and processor are too hot to touch for some time after the system has been powered down. Allow the heat sink and processor to cool down before handling them.
-  **CAUTION: Never remove the heat sink from a processor unless you intend to remove the processor. The heat sink is necessary to maintain proper thermal conditions.**
-  **NOTE:** If you are installing a single processor, it must be installed in socket CPU1.

Steps

1. Unpack the new processor.
 -  **NOTE:** If the processor has previously been used in a system, remove any remaining thermal grease from the processor by using a lint-free cloth.
2. Locate the processor socket.
3. If applicable, remove the socket protective cap.
4. Release the *open first* socket-release lever near the unlock icon  by pushing the lever down and out from under the tab.
5. Similarly, release the *close first* socket-release lever near the lock icon  by pushing the lever down and out from under the tab. Lift the lever 90 degrees upward.
6. Hold the tab near the lock symbol on the processor shield and lift it up and out of the way.
 -  **CAUTION: Positioning the processor incorrectly can permanently damage the system board or the processor. Be careful not to bend the pins in the socket.**
 -  **CAUTION: While removing or reinstalling the processor, wipe your hands of any contaminants. Contaminants on the processor pins such as thermal grease or oil can damage the processor.**
7. Align the processor with the socket keys.
 -  **CAUTION: Do not use force to seat the processor. When the processor is positioned correctly, it engages easily into the socket.**
8. Align the pin-1 indicator of the processor with the triangle on the system board.
9. Place the processor on the socket such that the slots on the processor align with the socket keys.
10. Close the processor shield.
11. Lower the *close first* socket-release lever near the lock icon  and push it under the tab to lock it.
12. Similarly, lower the *open first* socket-release lever near the unlock icon  and push it under the tab to lock it.

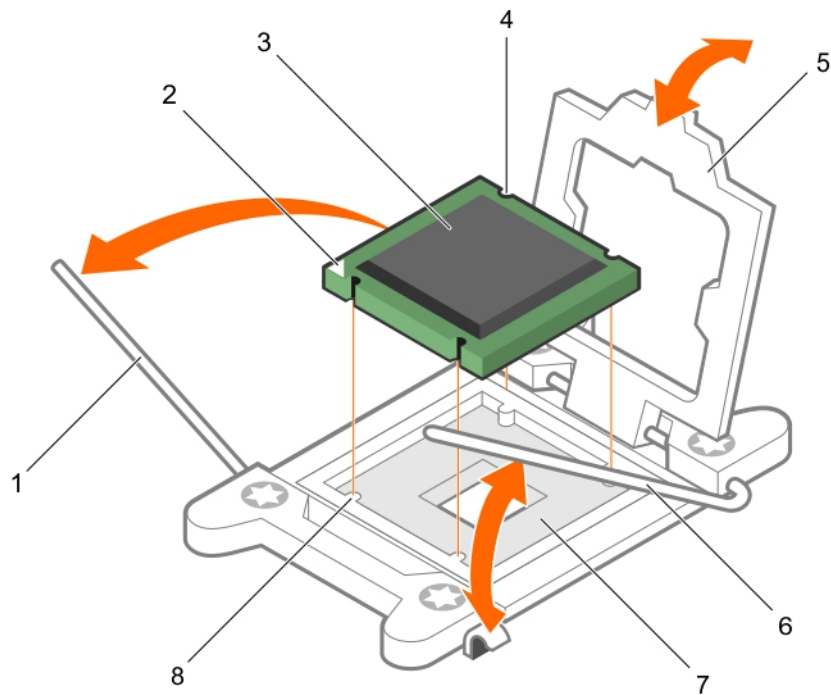

Figure 31. Installing a processor

- | | |
|---------------------------|----------------------------------|
| 1. socket-release lever 1 | 2. pin-1 corner of the processor |
| 3. processor | 4. slot (4) |
| 5. processor shield | 6. socket-release lever 2 |
| 7. processor socket | 8. tab (4) |

Next steps

NOTE: Ensure that you install the heat sink after you install the processor. The heat sink is necessary to maintain proper thermal conditions.

1. Install the heat sink.
2. If removed, reinstall the PCIe expansion card riser.
3. If disconnected, reconnect the cables to the expansion card(s).
4. Install the cooling shroud.
5. Follow the procedure listed in the After working inside your system.
6. While booting, press F2 to enter System Setup and verify that the processor information matches the new system configuration.
7. Run the system diagnostics to verify that the new processor operates correctly.

Related references

[Safety instructions](#) on page 48

Related tasks

[Before working inside your system](#) on page 49

PSUs

Your system supports one of the following:

- Two 750 W AC PSU modules or
- Two 750 W mixed mode PSU modules

 **NOTE:** Titanium PSU is nominally rated for 200 V AC to 240 V AC input only.

 **NOTE:** When two identical PSUs are installed, PSU redundancy (1+1 – with redundancy or 2+0 – without redundancy) is configured in system BIOS. In redundant mode, power is supplied to the system equally from both PSUs when the Hot Spare feature is disabled. When the Hot Spare feature is enabled, one of the PSUs will be put into standby when system utilization is low in order to maximize efficiency.

 **NOTE:** If two PSUs are used, they must be of the same maximum output power.

 **NOTE:** For AC PSUs, use only PSUs with the Extended Power Performance (EPP) label on the back. Mixing PSUs from previous generations of servers can result in a PSU mismatch condition or failure to turn on.

Hot spare feature

Your system supports the hot spare feature that significantly reduces the power overhead associated with power supply unit (PSU) redundancy.

When the hot spare feature is enabled, one of the redundant PSUs is switched to the sleep state. The active PSU supports 100 percent of the load, thus operating at higher efficiency. The PSU in the sleep state monitors output voltage of the active PSU. If the output voltage of the active PSU drops, the PSU in the sleep state returns to an active output state.

If having both PSUs active is more efficient than having one PSU in the sleep state, the active PSU can also activate the sleeping PSU.

The default PSU settings are as follows:

- If the load on the active PSU is more than 50 percent, then the redundant PSU is switched to the active state.
- If the load on the active PSU falls below 20 percent, then the redundant PSU is switched to the sleep state.

You can configure the hot spare feature by using the iDRAC settings. For more information about iDRAC settings, see the *Integrated Dell Remote Access Controller User's Guide* available at Dell.com/idracmanuals.

Removing the power supply unit blank

Install the power supply unit (PSU) blank only in the second PSU bay.

Prerequisites

 **CAUTION:** Many repairs may only be done by a certified service technician. You should only perform troubleshooting and simple repairs as authorized in your product documentation, or as directed by the online or telephone service and support team. Damage due to servicing that is not authorized by Dell is not covered by your warranty. Read and follow the safety instructions that are shipped with your product.

Follow the safety guidelines listed in the Safety instructions section.

Steps

If you are installing a second power supply unit (PSU), remove the PSU blank in the bay by pulling the blank outward.

 **CAUTION:** To ensure proper system cooling, the PSU blank must be installed in the second PSU bay in a non-redundant configuration. Remove the PSU blank only if you are installing a second PSU.

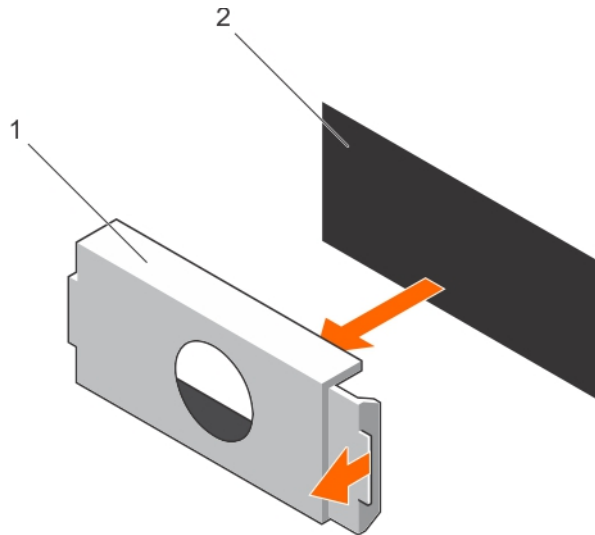

Figure 32. Removing the PSU blank

- a. PSU blank
- b. PSU bay

Next steps

Install the PSU or PSU blank.

Related references

[Safety instructions](#) on page 48

Installing the power supply unit blank

Install the power supply unit (PSU) blank only in the second PSU bay.

Prerequisites

CAUTION: Many repairs may only be done by a certified service technician. You should only perform troubleshooting and simple repairs as authorized in your product documentation, or as directed by the online or telephone service and support team. Damage due to servicing that is not authorized by Dell is not covered by your warranty. Read and follow the safety instructions that are shipped with your product.

1. Follow the safety guidelines listed in the Safety instructions section.

Steps

Align the power supply unit blank with the power supply unit slot and push it into the power supply unit slot until it clicks into place.

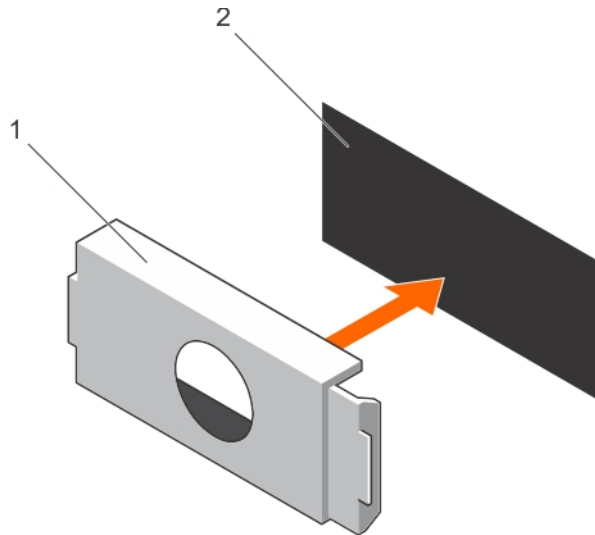

Figure 33. Installing the PSU blank

- a. PSU blank
- b. PSU bay

Related references

[Safety instructions](#) on page 48

Removing an AC power supply unit

Prerequisites

CAUTION: Many repairs may only be done by a certified service technician. You should only perform troubleshooting and simple repairs as authorized in your product documentation, or as directed by the online or telephone service and support team. Damage due to servicing that is not authorized by Dell is not covered by your warranty. Read and follow the safety instructions that are shipped with your product.

CAUTION: The system needs one power supply unit (PSU) for normal operation. On power-redundant systems, remove and replace only one PSU at a time in a system that is powered on.

If applicable, unlatch and lift the optional cable management arm if it interferes with the power supply unit (PSU) removal. For information about the cable management arm, see the system's rack documentation.

Follow the safety guidelines listed in the Safety instructions section.

Steps

1. Disconnect the power cable from the power source and from the PSU you intend to remove, and then remove the cables from the strap.
2. Press the release latch and slide the PSU out of the chassis by using the PSU handle.

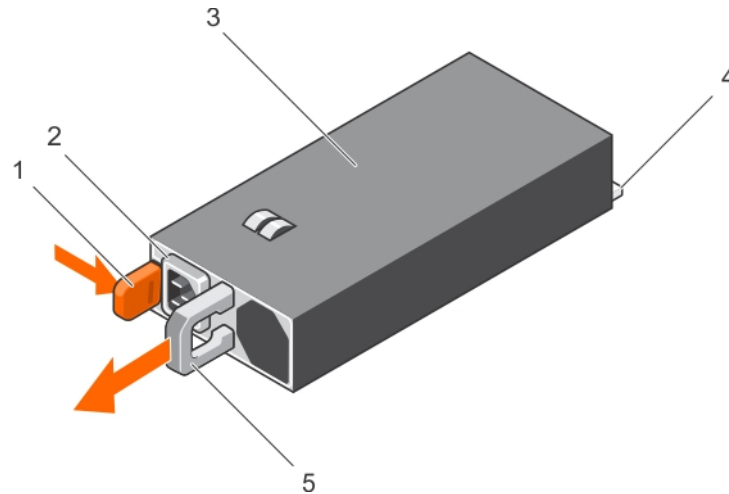

Figure 34. Removing an AC PSU

- | | |
|------------------|------------------------|
| 1. release latch | 2. PSU cable connector |
| 3. PSU | 4. power connector |
| 5. PSU handle | |

Next steps

- If applicable, install the AC PSU.
- If applicable, install the PSU blank.

Related references

[Safety instructions](#) on page 48

Installing an AC power supply unit

Prerequisites

CAUTION: Many repairs may only be done by a certified service technician. You should only perform troubleshooting and simple repairs as authorized in your product documentation, or as directed by the online or telephone service and support team. Damage due to servicing that is not authorized by Dell is not covered by your warranty. Read and follow the safety instructions that are shipped with your product.

NOTE: The maximum output power (shown in watts) is listed on the PSU label.

1. Follow the safety guidelines listed in the Safety instructions section.
2. For systems that support redundant power supply units (PSUs), ensure that both the PSUs are of the same type and have the same maximum output power.
3. If installed, remove the PSU blank.

Steps

1. Slide the PSU into the chassis until the PSU is fully seated and the release latch snaps into place.
2. If applicable, relatch the cable management arm.
For information about the cable management arm, see the rack documentation of your system.
3. Connect the power cable to the PSU, and plug the cable into a power outlet.

CAUTION: When connecting the power cable, secure the cable with the strap.

NOTE: When installing, hot swapping, or hot-adding a new PSU, wait for 15 seconds for the system to recognize the PSU and determine its status. The PSU redundancy may not occur until discovery is complete. Wait until the new PSU is

discovered and enabled before you remove the other PSU. The PSU status indicator turns green to signify that the PSU is functioning properly.

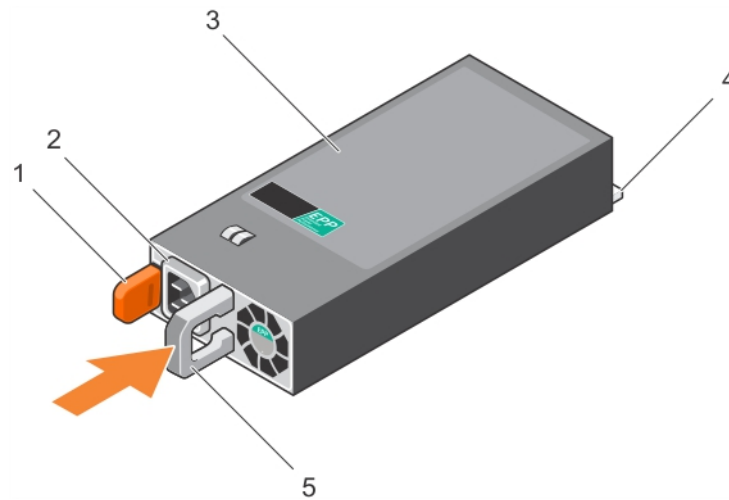

Figure 35. Installing an AC PSU

- | | |
|------------------|------------------------|
| 1. release latch | 2. PSU cable connector |
| 3. PSU | 4. power connector |
| 5. PSU handle | |

Related references

[Safety instructions](#) on page 48

System battery

The system battery is used to power the real-time clock and storing the system's BIOS settings.

Replacing the system battery

Prerequisites

NOTE: There is a danger of a new battery exploding if it is incorrectly installed. Replace the battery only with the same or equivalent type recommended by the manufacturer. For more information, see the safety information that shipped with your system.

CAUTION: Many repairs may only be done by a certified service technician. You should only perform troubleshooting and simple repairs as authorized in your product documentation, or as directed by the online or telephone service and support team. Damage due to servicing that is not authorized by Dell is not covered by your warranty. Read and follow the safety instructions that are shipped with your product.

1. Follow the safety guidelines listed in the Safety instructions section.
2. Follow the procedure listed in the Before working inside your system section.
3. Remove the cooling shroud.

Steps

1. Locate the battery socket. For more information, see the Jumpers and connectors section.

CAUTION: To avoid damage to the battery connector, you must firmly support the connector while installing or removing a battery.

2. Place your finger between the securing tabs at the negative side of the battery connector, and lift the battery out of the socket.

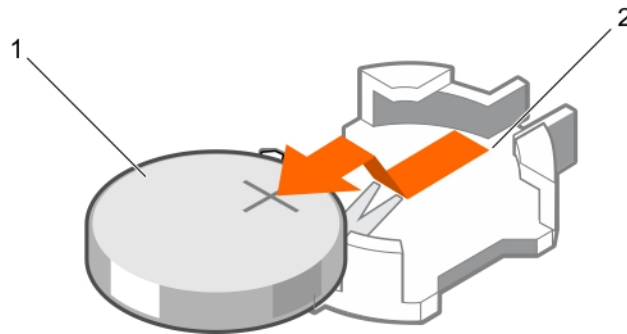

Figure 36. Removing the system battery

- a. system battery
- b. system battery slot

3. To install a new system battery, hold the battery with the "+" facing up and slide it under the securing tabs.
4. Press the battery into the connector until it snaps into place.

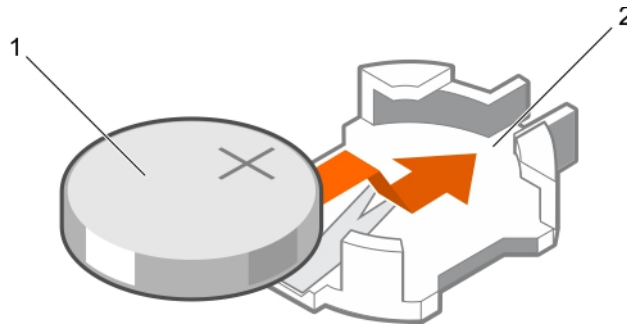

Figure 37. Installing the system battery

- a. system battery
- b. system battery slot

Next steps

1. Install the cooling shroud.
2. Follow the procedure listed in the After working inside your system section.
3. While booting, press F2 to enter System Setup and ensure the battery is operating properly.
4. Enter the correct time and date in the System Setup **Time** and **Date** fields.
5. Exit System Setup.

Related references

- [Safety instructions](#) on page 48
- [Jumpers and connectors](#) on page 111

Related tasks

- [Before working inside your system](#) on page 49
- [After working inside your system](#) on page 49

Hard disk drive backplane

The Dell Storage NX3330 system supports 2.5 inch (x4) SAS/SATA backplane.

Removing HDD backplane

Prerequisites

1. Ensure that you read the Safety instructions section in this document.
2. Complete the tasks listed in the Before working inside your system section in this document.
3. Remove all HDDs.

CAUTION: Many repairs may only be done by a certified service technician. You should only perform troubleshooting and simple repairs as authorized in your product documentation, or as directed by the online or telephone service and support team. Damage due to servicing that is not authorized by Dell is not covered by your warranty. Read and follow the safety instructions that are shipped with your product.

CAUTION: To prevent damage to the HDDs and HDD backplane, you must remove the HDDs from the system before removing the HDD backplane.

CAUTION: You must note the number of each HDD and temporarily label them before removal so that you can replace them in the same locations.

Steps

1. Disconnect the SAS/SATA/SSD data cable(s) and power cable from the backplane.
2. If applicable, disconnect the power/data cable from the optical drive.
3. Push the backplane blue release tabs in the direction of the arrows and lift the backplane upwards.
4. Pull the backplane away from the system until the securing slots on the backplane are free from the tabs on the chassis.

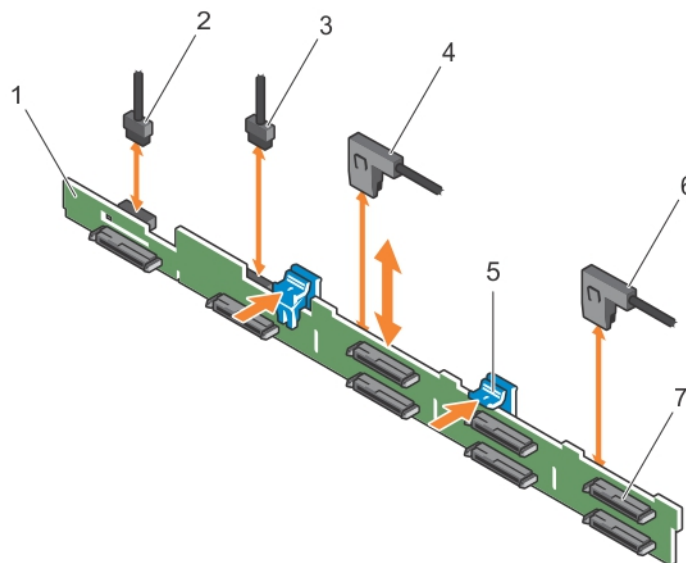

Figure 38. Removing and installing the 2.5-inch (x8) HDD backplane

- | | |
|-----------------------------------|---------------------------|
| 1. backplane | 2. backplane signal cable |
| 3. backplane signal cable | 4. SAS A cable |
| 5. release tabs (2) | 6. SAS B cable |
| 7. SAS HDD connector on backplane | |

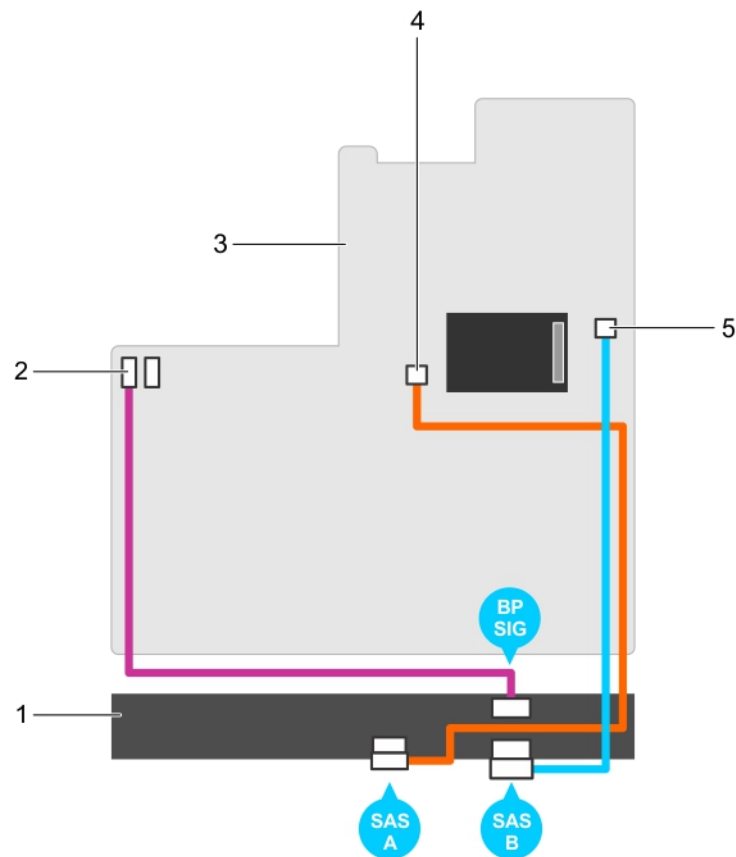

Figure 39. Cabling diagram — 2.5-inch (x8) systems

1. SAS backplane
2. signal connector on system board
3. system board
4. SAS A connector on system board
5. SAS B connector on system board

Related references

[Safety instructions](#) on page 48

Related tasks

[Before working inside your system](#) on page 49

Installing HDD backplane

Prerequisites

1. Ensure that you read the Safety instructions section in this document.
2. Complete the tasks listed in the Before working inside your system section in this document.

CAUTION: Many repairs may only be done by a certified service technician. You should only perform troubleshooting and simple repairs as authorized in your product documentation, or as directed by the online or

telephone service and support team. Damage due to servicing that is not authorized by Dell is not covered by your warranty. Read and follow the safety instructions that are shipped with your product.

Steps

1. Use the hooks on the chassis as guides to align the HDD backplane.
2. Lower the HDD backplane until the release tabs snap into place.
3. Connect the SAS/SATA/SSD data, signal, and power cable(s) to the backplane.

Next steps

1. Install the HDDs in their original locations.
2. Complete the tasks listed in the After working inside your system section in this document.

Related references

[Safety instructions](#) on page 48

Related tasks

[Before working inside your system](#) on page 49

[After working inside your system](#) on page 49

Control panel

The control panel contains the power button, the diagnostic indicators, and the front USB ports.

Removing control panel board–8 HDD system

Prerequisites

1. Ensure that you read the Safety instructions section in this document.
2. Follow the procedure listed in the Before working inside your system section in this document.
3. Keep the #2 Philips screwdriver ready.

CAUTION: Many repairs may only be done by a certified service technician. You should only perform troubleshooting and simple repairs as authorized in your product documentation, or as directed by the online or telephone service and support team. Damage due to servicing that is not authorized by Dell is not covered by your warranty. Read and follow the safety instructions that are shipped with your product.

CAUTION: The display module connector is a ZIF (zero insertion force) connector. Ensure that the locking tab on the connector is released before removal and insertion. The locking tab must be engaged after insertion.

Steps

1. Disconnect the control panel and display module cables from the control panel board.
2. Using a #2 Philips screwdriver, remove the two screws that secure the control panel board to the chassis.
3. Slide the control panel board toward the back and out of the system.

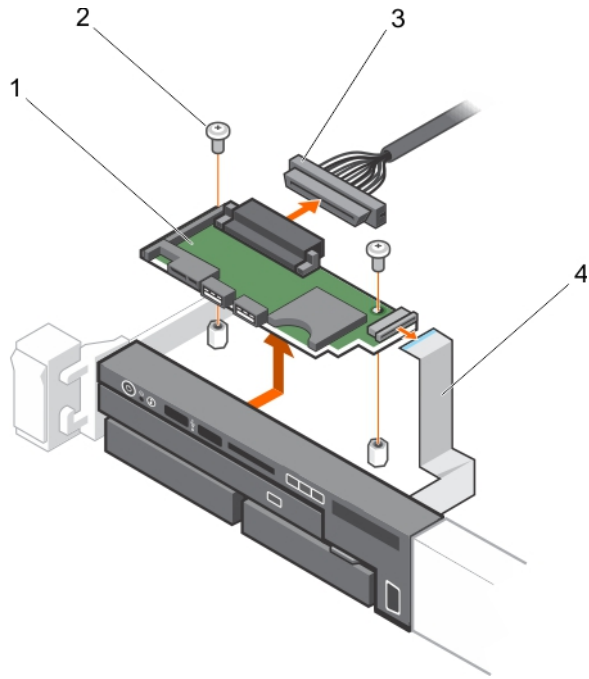

Figure 40. Removing and installing the control panel board

- | | |
|------------------------|-------------------------|
| 1. control panel board | 2. screws (2) |
| 3. control-panel cable | 4. display module cable |

Related references

[Safety instructions](#) on page 48

Related tasks

[Before working inside your system](#) on page 49

[After working inside your system](#) on page 49

Installing the control panel board—eight hard drive system

Prerequisites

CAUTION: Many repairs may only be done by a certified service technician. You should only perform troubleshooting and simple repairs as authorized in your product documentation, or as directed by the online or telephone service and support team. Damage due to servicing that is not authorized by Dell is not covered by your warranty. Read and follow the safety instructions that are shipped with your product.

1. Follow the safety guidelines listed in the Safety instructions section.
2. Keep the Philips #2 screwdriver ready.

Steps

1. Align the screw holes on the control panel board with the standoffs on the chassis.
2. Replace the two screws that secure the control panel board to the chassis.

CAUTION: The display module connector is a ZIF (zero insertion force) connector. Ensure that the locking tab on the connector is released before removal and insertion. The locking tab must be engaged after insertion.

3. Connect control panel and display module cables to the control panel board.
4. If required, route the power and data cables along the chassis wall.

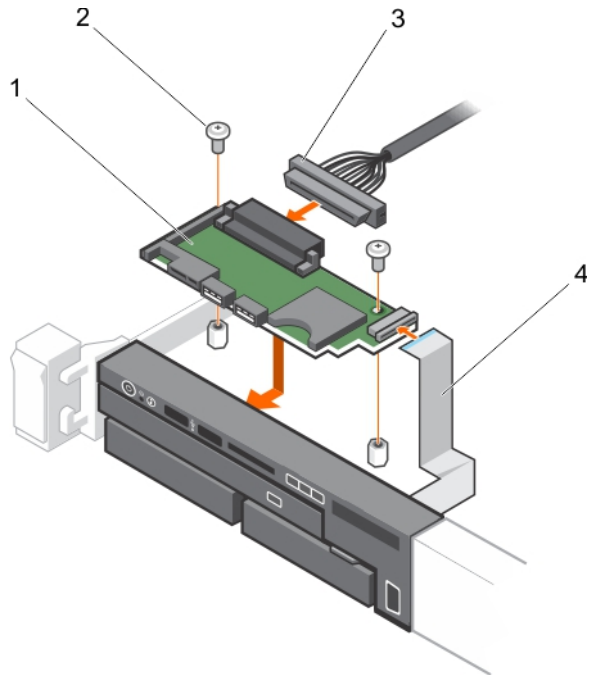

Figure 41. Installing the control panel board

- | | |
|------------------------|-------------------------|
| 1. control panel board | 2. screws (2) |
| 3. control panel cable | 4. display module cable |

Next steps

Follow the procedure listed in the After working inside your system section.

Related tasks

[After working inside your system](#) on page 49

Removing control panel–8 HDD system

Prerequisites

1. Ensure that you read the Safety instructions section in this document.
2. Complete the procedure listed in the Before working inside your system section in this document.
3. Keep the #1 Philips screwdriver ready.

CAUTION: Many repairs may only be done by a certified service technician. You should only perform troubleshooting and simple repairs as authorized in your product documentation, or as directed by the online or telephone service and support team. Damage due to servicing that is not authorized by Dell is not covered by your warranty. Read and follow the safety instructions that are shipped with your product.

CAUTION: The display module connector is a ZIF (zero insertion force) connector. Ensure that the locking tab on the connector is released before removal and insertion. The locking tab must be engaged after insertion.

Steps

1. Disconnect the display module cable from the control panel board.
2. Using a #1 Philips screwdriver, remove the screw (located at the bottom of the chassis) that secures the control module to the chassis.

NOTE: Apart from the screw, the control panel has three tabs (one on the left and two tabs on top) that secure it to the chassis.

CAUTION: Applying excessive force while pulling upward may damage the control panel.

3. Hold the top edge of the control panel at the corners and pull upward until the control panel tabs are released.
4. Hold the right edge of the control panel and rotate it toward the left until it is released from the chassis.
5. Pull the control panel away from the chassis.

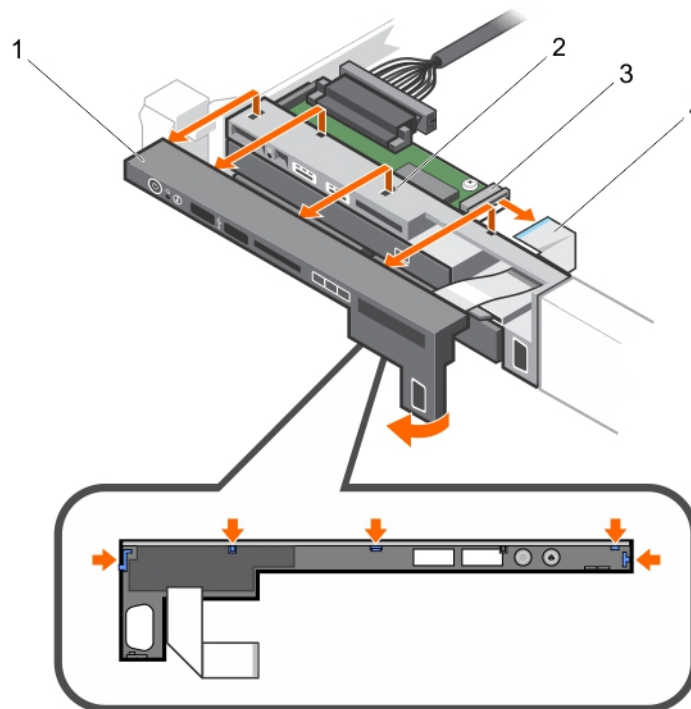

Figure 42. Removing and installing the control panel

- | | |
|---------------------------------|------------------------------------|
| 1. control panel | 2. notch on chassis front wall (2) |
| 3. display module ZIF connector | 4. display module cable |

Related references

[Safety instructions](#) on page 48

Related tasks

[Before working inside your system](#) on page 49

Installing control panel–8 HDD system

Prerequisites

CAUTION: Many repairs may only be done by a certified service technician. You should only perform troubleshooting and simple repairs as authorized in your product documentation, or as directed by the online or telephone service and support team. Damage due to servicing that is not authorized by Dell is not covered by your warranty. Read and follow the safety instructions that are shipped with your product.

Keep the #1 Philips screwdriver ready.

Steps

1. Slide the left side of the control panel into the chassis so that the left tab on the control panel aligns with the slot on the chassis wall and the top left tab aligns with the slot on the top of the chassis.
2. Pull the display module cable through the opening and into the chassis.

3. Push the right side of the control panel until the top right tab aligns with the top of the chassis and the panel snaps into place.
4. Using a #1 Philips screwdriver, replace the screw (located at the bottom of the chassis) that secures the control module to the chassis.

 **CAUTION:** The display module connector is a ZIF (zero insertion force) connector. Ensure that the locking tab on the connector is released before removal and insertion. The locking tab must be engaged after insertion.

5. Connect the display module cable to the control panel board.

Next steps

Follow the procedure listed in the After working inside your system section in this document.

Related tasks

[After working inside your system](#) on page 49

VGA module

 **NOTE:** Only the eight hard drive system has a VGA module on the front panel.

Removing the VGA module

Prerequisites

 **CAUTION:** Many repairs may only be done by a certified service technician. You should only perform troubleshooting and simple repairs as authorized in your product documentation, or as directed by the online or telephone service and support team. Damage due to servicing that is not authorized by Dell is not covered by your warranty. Read and follow the safety instructions that are shipped with your product.

 **CAUTION:** The display module connector is a ZIF (zero insertion force) connector. Ensure that the locking tab on the connector is released before removal and insertion. The locking tab must be engaged after insertion.

1. Follow the safety guidelines listed in the Safety instructions section.
2. Follow the procedure listed in the Before working inside your system section.
3. Keep the Philips #2 screwdriver ready.

Steps

1. Disconnect the display module cable from the control panel board.
2. Remove the control panel.
3. Disconnect the VGA module cable from the VGA module.
4. Remove the screw that secures the VGA module to the chassis.
5. Slide the VGA module out of the chassis.

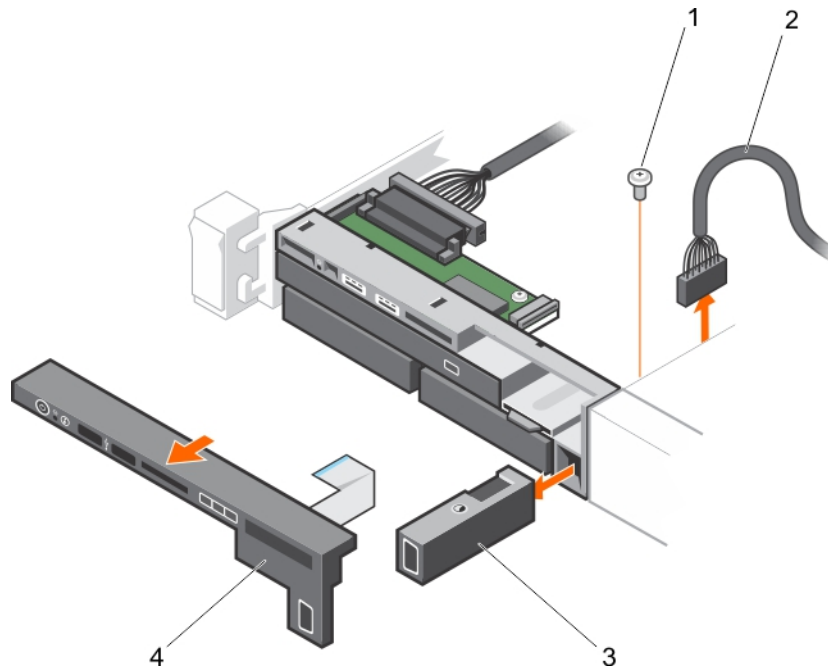

Figure 43. Removing the VGA Module

- | | |
|---------------|---------------------|
| 1. screw | 2. VGA module cable |
| 3. VGA module | 4. control panel |

Related references

[Safety instructions](#) on page 48

Related tasks

[Before working inside your system](#) on page 49

Installing the VGA module

Prerequisites

CAUTION: Many repairs may only be done by a certified service technician. You should only perform troubleshooting and simple repairs as authorized in your product documentation, or as directed by the online or telephone service and support team. Damage due to servicing that is not authorized by Dell is not covered by your warranty. Read and follow the safety instructions that are shipped with your product.

NOTE: This procedure applies only to the eight hard drive system.

1. Follow the safety guidelines listed in the Safety instructions section.
2. Keep the Philips #2 screwdriver ready.

Steps

1. Push the VGA module into the chassis and align the threaded screw hole on the VGA module with the screw hole on the chassis.
2. Replace the screw (at the bottom of the chassis) that secures the VGA module to the chassis.
3. Replace the control panel.
4. Connect the VGA module cable to the VGA module.

CAUTION: The display module connector is a ZIF (zero insertion force) connector. Ensure that the locking tab on the connector is released before removal and insertion. The locking tab must be engaged after insertion.

5. Connect the display module cables to the control panel board.

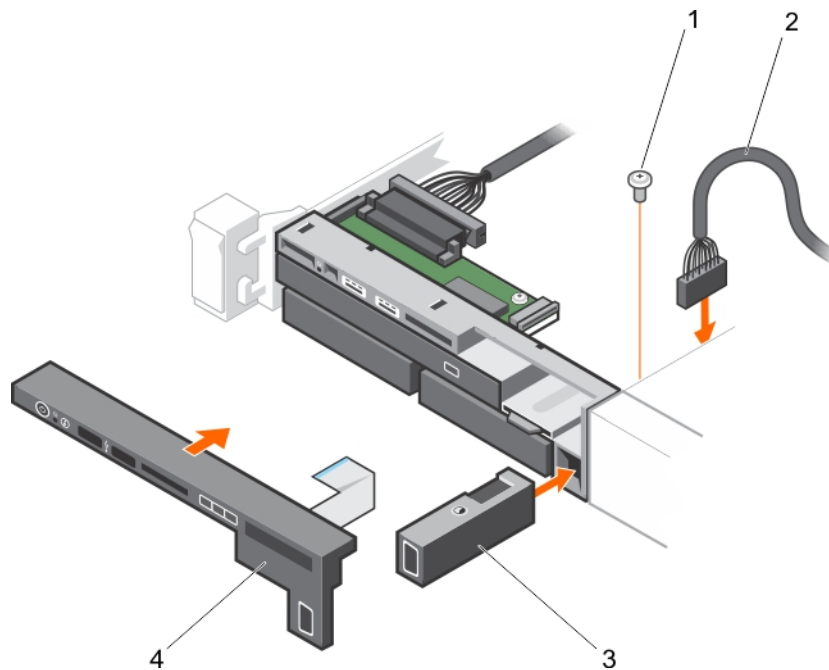

Figure 44. Installing the VGA module

- 1. screw
- 2. VGA module cable
- 3. VGA module
- 4. control panel

Next steps

Follow the procedure listed in the After working inside your system section.

Related references

[Safety instructions](#) on page 48

Related tasks

[After working inside your system](#) on page 49

System board

Removing system board

Prerequisites

CAUTION: Many repairs may only be done by a certified service technician. You should only perform troubleshooting and simple repairs as authorized in your product documentation, or as directed by the online or telephone service and support team. Damage due to servicing that is not authorized by Dell is not covered by your warranty. Read and follow the safety instructions that are shipped with your product.

CAUTION: If you are using the Trusted Platform Module (TPM) with an encryption key, you may have to create a recovery key during program or System Setup. Ensure to create and safely store this recovery key. If you replace

this system board, you must supply the recovery key when you restart your system or program before you can access the encrypted data on your HDDs.

CAUTION: Do not attempt to remove the TPM plug-in module from the motherboard. Once the TPM plug-in module is installed, it is cryptographically bound to that specific motherboard. Any attempt to remove an installed TPM plug-in module breaks the cryptographic binding, and it cannot be reinstalled or installed on another motherboard.

1. Ensure that you read the Safety instructions section in this document.
2. Complete the tasks listed in the Before working inside your system section in this document.
3. Remove the following:

- a. Cooling shroud
- b. Memory modules
- c. Cooling fans
- d. PSUs
- e. All expansion-card risers and expansion cards

NOTE: The heat sink is hot to touch for some time after the system has been powered down. Ensure that you do not touch the heat sinks while removing the system board.

- f. Heat sinks/heat-sink blanks and processors/processor blanks

CAUTION: To prevent damage to the processor pins when replacing a faulty system board, ensure that you cover the processor socket with the processor protective cap.

- g. Integrated storage controller card
- h. Network daughter card
- i. Internal dual SD module
- j. Hot-swap HDDs
- k. HDD backplane

CAUTION: To avoid damaging the mini SAS cable and connector, follow the correct procedure when removing the mini SAS cable from the system board.

Steps

1. Disconnect the mini SAS cable from the system board.
 - a. Push the mini SAS cable connector to slide it further into the connector on the system board.
 - b. Press down, and hold the metal tab on the mini SAS cable connector.
 - c. Pull the mini SAS cable out of the connector on the system board.
2. Disconnect all other cables from the system board.

CAUTION: Take care not to damage the system identification button while removing the system board from the chassis.

3. Grasp the system-board holder, lift the blue release pin, slide the system board toward the front of the system, and lift the system board out of the chassis.

CAUTION: Do not lift the system board by holding a memory module, processor, or other components.

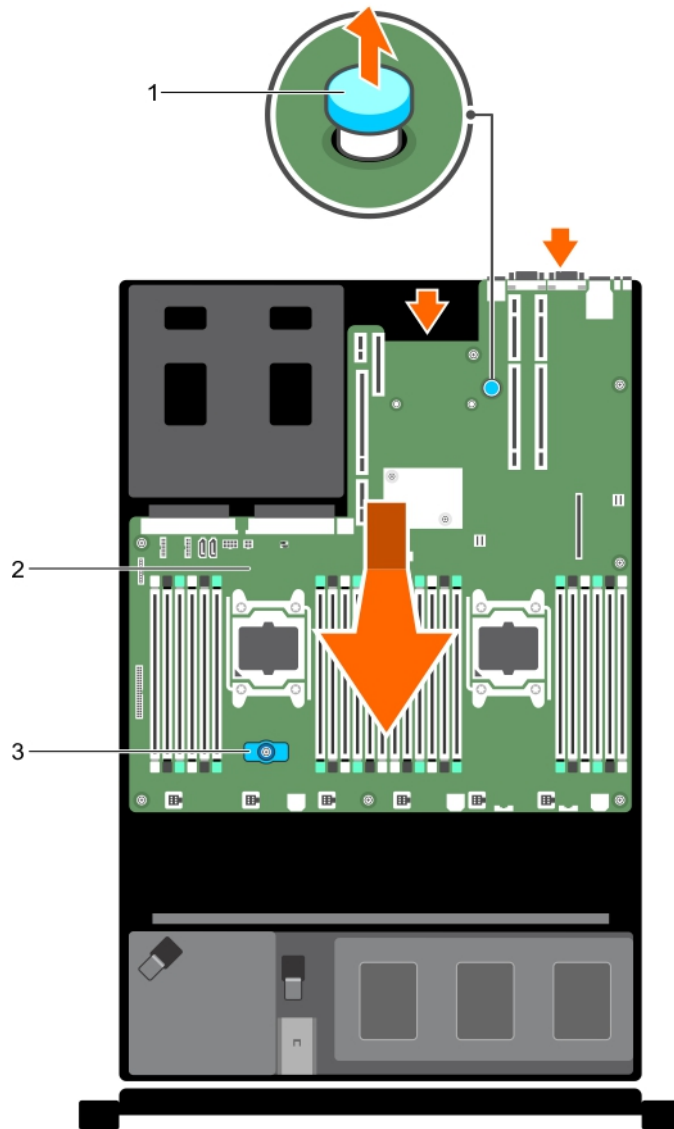

Figure 45. Removing and Installing the System Board

- a. System board holder
- b. System-board
- c. Release pin

Related references

[Safety instructions](#) on page 48

Related tasks

[Before working inside your system](#) on page 49

Installing system board

Prerequisites

CAUTION: Many repairs may only be done by a certified service technician. You should only perform troubleshooting and simple repairs as authorized in your product documentation, or as directed by the online or telephone service and support team. Damage due to servicing that is not authorized by Dell is not covered by your warranty. Read and follow the safety instructions that are shipped with your product.

Steps

1. Unpack the new system board assembly.

 **CAUTION:** Do not lift the system board by holding a memory module, processor, or other components.

 **CAUTION:** Take care not to damage the system identification button while placing the system board into the chassis.

2. Hold the touch points and lower the system board into the chassis.
3. Push the system board toward the back of the chassis until the board is seated correctly.

Next steps

1. Install the Trusted Platform Module (TPM). For information on how to install TPM, see the Installing the Trusted Platform Module section in this document. For more information about TPM, see the Trusted Platform Module section in this document.
2. Replace the following:
 - a. cable retention bracket
 - b. PCIe card holder
 - c. integrated storage controller card
 - d. internal dual SD module
 - e. all expansion card risers
 - f. heat sink(s) or heat-sink blank(s) and processors(s)/processor blank(s)
 - g. memory modules and memory module blanks
 - h. network daughter card
 - i. cooling-fan assembly
 - j. cooling shroud
 - k. PSUs
3. Reconnect all cables to the system board.

 **NOTE:** Ensure that the cables inside the system are routed along the chassis wall and secured using the cable securing bracket.
4. Complete the tasks listed in the After working inside your system section in this document.
5. Import your new or existing iDRAC Enterprise license. For more information, see the *Integrated Dell Remote Access Controller User's Guide*, at dell.com/esmmanuals.
6. Ensure that you:
 - a. Use the **Easy Restore** feature to restore the Service Tag. For more information, see the Easy Restore section in this document.
 - b. If the service tag is not backed up in the backup flash device, type the system Service Tag manually. For more information, see the Entering the system Service Tag section in this document.
 - c. Update the BIOS and iDRAC versions.
 - d. Reenable the Trusted Platform Module (TPM). For more information, see the Re-enabling the TPM for BitLocker users or Reenabling the TPM for Intel TXT users section in this document.

Related tasks

[Installing the Trusted Platform Module](#) on page 106

[After working inside your system](#) on page 49

[Restoring the Service Tag by using the Easy Restore feature](#) on page 106

[Entering the system Service Tag by using System Setup](#) on page 106

[Initializing the TPM for BitLocker users](#) on page 107

[Initializing the TPM for TXT users](#) on page 108

Entering the system Service Tag by using System Setup

If Easy Restore fails to restore the Service Tag, use System Setup to enter the Service Tag.

Steps

1. Turn on the system.
2. Press F2 to enter System Setup.
3. Click **Service Tag Settings**.
4. Enter the Service Tag.

 **NOTE:** You can enter the Service Tag only when the **Service Tag** field is empty. Ensure that you enter the correct Service Tag. After the Service Tag is entered, it cannot be updated or changed.

5. Click **Ok**.
6. Import your new or existing iDRAC Enterprise license.

For more information, see the *Integrated Dell Remote Access Controller User's Guide* at Dell.com/idracmanuals.

Restoring the Service Tag by using the Easy Restore feature

By using the Easy Restore feature, you can restore your system's Service Tag, license, UEFI configuration, and the system configuration data after replacing the system board. All data is automatically backed up in a backup flash device. If BIOS detects a new system board and the Service Tag in the backup flash device, BIOS prompts the user to restore the backup information.

Steps

1. Turn on the system.
If BIOS detects a new system board, and if the Service Tag is present in the backup flash device, BIOS displays the Service Tag, the status of the license, and the **UEFI Diagnostics** version.
2. Perform one of the following steps:
After the restore process is complete, BIOS prompts to restore the system configuration data.
3. Perform one of the following steps:
 - Press **Y** to restore the system configuration data.
 - Press **N** to use the default configuration settings.

After the restore process is complete, the system restarts.

Trusted Platform Module

Trusted Platform Module (TPM) is a dedicated microprocessor designed to secure hardware by integrating cryptographic keys into devices. A software can use a Trusted Platform Module to authenticate hardware devices. As each TPM chip has a unique and secret RSA key burned in as it is produced, it can perform the platform authentication.

 **CAUTION:** Do not attempt to remove the Trusted Platform Module (TPM) from the system board. After the TPM is installed, it is cryptographically bound to that specific system board. Any attempt to remove an installed TPM breaks the cryptographic binding, and it cannot be re-installed or installed on another system board.

 **NOTE:** This is a Field Replaceable Unit (FRU). Removal and installation procedures must be performed only by Dell certified service technicians.

Installing the Trusted Platform Module

Prerequisites

 **CAUTION:** Many repairs may only be done by a certified service technician. You should only perform troubleshooting and simple repairs as authorized in your product documentation, or as directed by the online or telephone service and support team. Damage due to servicing that is not authorized by Dell is not covered by your warranty. Read and follow the safety instructions that are shipped with your product.

1. Follow the safety guidelines listed in the Safety instructions section.
2. Follow the procedure listed in the Before working inside your system section.

Steps

1. Locate the TPM connector on the system board.

i **NOTE:** To locate the TPM connector on the system board, see the System board connectors section.

2. Align the edge connectors on the TPM with the slot on the TPM connector.
3. Insert the TPM into the TPM connector such that the plastic rivet aligns with the slot on the system board.
4. Press the plastic rivet until the rivet snaps into place.

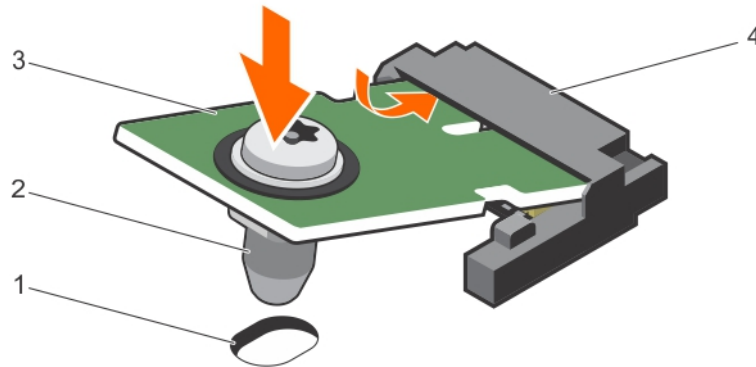

Figure 46. Installing the TPM

- | | |
|-----------------------------------|------------------|
| 1. rivet slot on the system board | 2. plastic rivet |
| 3. TPM | 4. TPM connector |

Next steps

1. Install the system board.
2. Follow the procedure listed in the After working inside your system section.

Related references

[Safety instructions](#) on page 48

[System board connectors](#) on page 112

Related tasks

[Before working inside your system](#) on page 49

[After working inside your system](#) on page 49

Initializing the TPM for BitLocker users

Steps

Initialize the TPM.

For more information about initializing the TPM, see <http://technet.microsoft.com/en-us/library/cc753140.aspx>.

The **TPM Status** changes to **Enabled, Activated**.

Initializing the TPM for TXT users

Steps

1. While booting your system, press F2 to enter System Setup.
2. On the **System Setup Main Menu** screen, click **System BIOS** → **System Security Settings**.
3. From the **TPM Security** option, select **On with Pre-boot Measurements**.
4. From the **TPM Command** option, select **Activate**.
5. Save the settings.
6. Restart your system.
7. Enter **System Setup** again.
8. On the **System Setup Main Menu** screen, click **System BIOS** → **System Security Settings**.
9. From the **Intel TXT** option, select **On**.

Using system diagnostics

If you experience a problem with your system, run the system diagnostics before contacting Dell for technical assistance. The purpose of running system diagnostics is to test your system hardware without using additional equipment or risking data loss. If you are unable to fix the problem yourself, service and support personnel can use the diagnostics results to help you solve the problem.

Topics:

- [Dell Embedded System Diagnostics](#)

Dell Embedded System Diagnostics

 **NOTE:** The Dell Embedded System Diagnostics is also known as Enhanced Pre-boot System Assessment (ePSA) diagnostics.

The Embedded System Diagnostics provides a set of options for particular device groups or devices allowing you to:

- Run tests automatically or in an interactive mode
- Repeat tests
- Display or save test results
- Run thorough tests to introduce additional test options to provide extra information about the failed device(s)
- View status messages that inform you if tests are completed successfully
- View error messages that inform you of problems encountered during testing

When to use the Embedded System Diagnostics

If a major component or device in the system does not operate properly, running the embedded system diagnostics may indicate component failure.

Running the Embedded System Diagnostics from Boot Manager

Prerequisites

Run the Embedded System Diagnostics (ePSA) if your system does not boot.

Steps

1. When the system is booting, press F11.
2. Use the up arrow and down arrow keys to select **System Utilities > Launch Diagnostics**.
The **ePSA Pre-boot System Assessment** window is displayed, listing all devices detected in the system. The diagnostics starts executing the tests on all the detected devices.

Running the Embedded System Diagnostics from the Dell Lifecycle Controller

Steps

1. As the system boots, press F11.
2. Select **Hardware Diagnostics → Run Hardware Diagnostics**.
The **ePSA Pre-boot System Assessment** window is displayed, listing all devices detected in the system. The diagnostics starts executing the tests on all the detected devices.

System diagnostic controls

Menu	Description
Configuration	Displays the configuration and status information of all detected devices.
Results	Displays the results of all tests that are run.
System health	Provides the current overview of the system performance.
Event log	Displays a time-stamped log of the results of all tests run on the system. This is displayed if at least one event description is recorded.

Jumpers and connectors

This topic provides specific information about the system jumpers. It also provides some basic information about jumpers and switches and describes the connectors on the various boards in the system. Jumpers on the system board help to disable system and setup passwords. You must know the connectors on the system board to install components and cables correctly.





Topics:

- [System board jumper settings](#)
- [System board connectors](#)
- [Disabling forgotten password](#)

System board jumper settings

For information about resetting the password jumper to disable a password, see the [Disabling a forgotten password](#) section.

Table 26. System board jumper settings

Jumper	Setting	Description
PWRD_EN	 2 4 6 (default)	The password reset feature is enabled (pins 2–4).
	 2 4 6	The password reset feature is disabled (pins 4–6). The iDRAC local access is unlocked at the next AC power cycle.
NVRAM_CLR	 1 3 5 (default)	The configuration settings are retained at the next system boot (pins 3–5).
	 1 3 5	The configuration settings are cleared at system boot (pins 1–3).

Related tasks

[Disabling forgotten password](#) on page 114

System board connectors

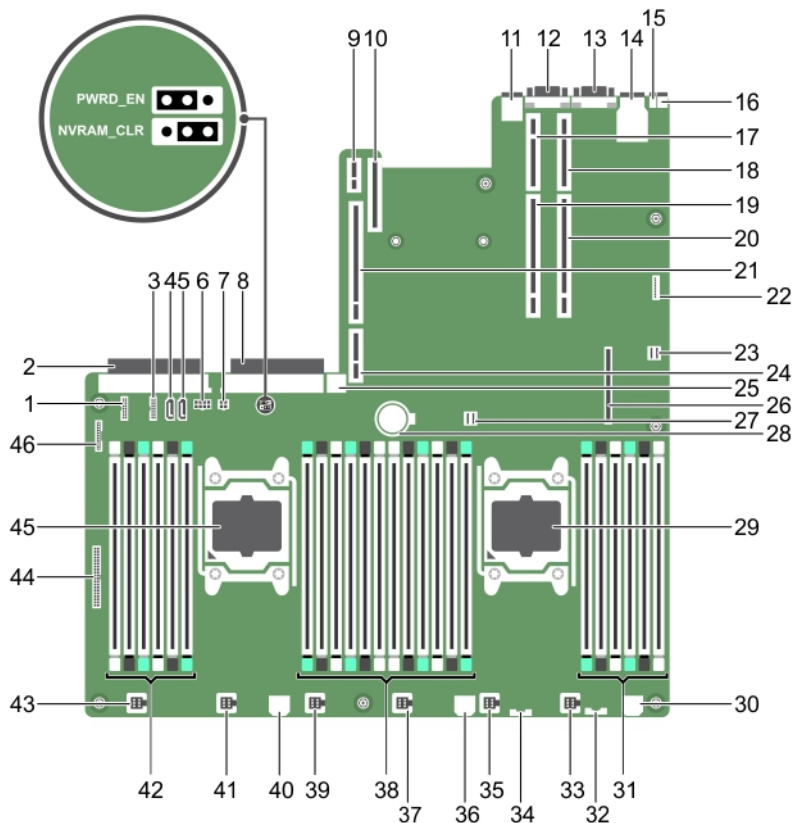

Figure 47. System board connectors and jumpers

Table 27. System board connectors and jumpers

Item	Connector	Description
1.	J_BP_SIG1	Backplane signal connector 1
2.	J_PS2	PSU 2 power connector
3.	J_BP_SIG0	Backplane signal connector 0
4.	J_SATA_CD	Optical drive SATA connector
5.	J_SATA_TBU	SATA tape backup unit connector
6.	J_BP0	Backplane power connector
7.	J_TBU	Tape backup unit power connector
8.	J_PS1	PSU 2 power connector
9.	J_IDSMD	Internal dual SD module connector
10.	J_NDC	Network daughter card connector
11.	J_USB	USB connector
12.	J_VIDEO_REAR	Video connector
13.	J_COM1	Serial connector
14.	J_IDRAC_RJ45	iDRAC7 connector
15.	J_CYC	System identification connector

Table 27. System board connectors and jumpers (continued)

Item	Connector	Description
16	CYC_ID	System identification button
17	J_RISER_2AX	Riser 2 connector
18	J_RISER_1AX	Riser 1 connector
19	J_RISER_2BX	Riser 2 connector
20	J_RISER_1BX	Riser 1 connector
21	J_RISER_3AX	Riser 3 connector
22	J_SATA_B	SATA connector
23	J_QS	Quick Sync connector
24	J_RISER_3BX	Riser 3 connector
25	J_USB_INT	Internal USB connector
26	J_STORAGE	Storage controller card connector
27	J_SATA_A	SATA connector
28	BAT	Battery connector
29	CPU2	Processor socket 2
30	J_FAN1U_7	Cooling fan connector
31	B1, B5, B9, B2, B6, B10	Memory module sockets
32	J_BP3	HDD backplane power connector
33	J_FAN1U_6	Cooling fan connector
34	J_BP_SIG2	Backplane signal connector 2
35	J_FAN1U_5	Cooling fan connector
36	J_BATT_SIG	Battery signal connector
37	J_FAN1U_4	Cooling fan connector
38	A1, A5, A9, A2, A6, A10, B3, B7, B11, B4, B8, B12	Memory module sockets
39	J_FAN1U_3	Cooling fan connector
40	J_FAN2U	Cooling fan connector
41	J_FAN1U_2	Cooling fan connector
42	A12, A8, A4, A7, A11, A3	Memory module sockets
43	J_FAN1U_1	Cooling fan connector
44	J_CTRL_PNL	Control panel connector
45	CPU1	Processor socket 1
46	J_FP_USB	Front panel USB connector

Disabling forgotten password

The system's software security features include a system password and a setup password. The password jumper enables these password features or disables them and clears any password(s) currently in use.

Prerequisites

 **CAUTION:** Many repairs may only be done by a certified service technician. You should only perform troubleshooting and simple repairs as authorized in your product documentation, or as directed by the online or telephone service and support team. Damage due to servicing that is not authorized by Dell is not covered by your warranty. Read and follow the safety instructions that are shipped with your product.

Steps

1. Turn off the system, including any attached peripherals, and disconnect the system from the electrical outlet.
2. Open the system.
3. Move the jumper on the system-board jumper from pins 4 and 6 to pins 2 and 4.
4. Close the system.

The existing passwords are not disabled (erased) until the system boots with the jumper on pins 2 and 4. However, before you assign a new system and/or setup password, you must move the jumper back to pins 4 and 6.

 **NOTE:** If you assign a new system and/or setup password with the jumper on pins 2 and 4, the system disables the new password(s) the next time it boots.

5. Reconnect the system to its electrical outlet and turn the system on, including any attached peripherals.
6. Turn off the system, including any attached peripherals, and disconnect the system from the electrical outlet.
7. Open the system.
8. Move the jumper on the system-board jumper from pins 2 and 4 to pins 4 and 6.
9. Close the system.
10. Reconnect the system to its electrical outlet and turn the system on, including any attached peripherals.
11. Assign a new system and/or setup password.

Troubleshooting your system

Safety first — for you and your system

CAUTION: Many repairs may only be done by a certified service technician. You should only perform troubleshooting and simple repairs as authorized in your product documentation, or as directed by the online or telephone service and support team. Damage due to servicing that is not authorized by Dell is not covered by your warranty. Read and follow the safety instructions that are shipped with your product.

NOTE: Solution validation was performed by using the factory shipped hardware configuration.

Topics:

- [Troubleshooting system startup failure](#)
- [Troubleshooting external connections](#)
- [Troubleshooting the video subsystem](#)
- [Troubleshooting a USB device](#)
- [Troubleshooting iDRAC Direct \(USB XML configuration\)](#)
- [Troubleshooting iDRAC Direct \(Laptop connection\)](#)
- [Troubleshooting a serial I/O device](#)
- [Troubleshooting a NIC](#)
- [Troubleshooting a wet system](#)
- [Troubleshooting a damaged system](#)
- [Troubleshooting the system battery](#)
- [Troubleshooting power supply units](#)
- [Troubleshooting cooling problems](#)
- [Troubleshooting cooling fans](#)
- [Troubleshooting system memory](#)
- [Troubleshooting an internal USB key](#)
- [Troubleshooting an optical drive](#)
- [Troubleshooting a tape backup unit](#)
- [Troubleshooting a hard drive or SSD](#)
- [Troubleshooting a storage controller](#)
- [Troubleshooting expansion cards](#)
- [Troubleshooting processors](#)
- [System messages](#)

Troubleshooting system startup failure

If you boot the system to the BIOS boot mode after installing an operating system from the UEFI Boot Manager, the system stops responding. To avoid this issue, you must boot to the same boot mode in which you installed the operating system.

For all other startup issues, note the system messages that appear on the screen.

Troubleshooting external connections

Before troubleshooting any external devices, ensure that all external cables are securely attached to the external connectors on your system before troubleshooting any external devices.

Troubleshooting the video subsystem

Prerequisites

 **NOTE:** Ensure the **Local Server Video Enabled** option is selected in the iDRAC Graphical User Interface (GUI), under **Virtual Console**. If this option is not selected, local video is disabled.

Steps

1. Check the cable connections (power and display) to the monitor.
2. Check the video interface cabling from the system to the monitor.
3. Run the appropriate diagnostic test.

Results

If the tests run successfully, the problem is not related to video hardware.

Next steps

If the tests fail, see the Getting help section.

Related references

[Getting help](#) on page 129

Troubleshooting a USB device

Prerequisites

 **NOTE:** Follow steps 1 to 6 to troubleshoot a USB keyboard or mouse. For other USB devices, go to step 7.

Steps

1. Disconnect the keyboard and/or mouse cables from the system and reconnect them.
2. If the problem persists, connect the keyboard and/or mouse to another USB port on the system.
3. If the problem is resolved, restart the system, enter System Setup, and check if the non-functioning USB ports are enabled.
 **NOTE:** Older operating systems may not support USB 3.0.
4. Check if USB 3.0 is enabled in System Setup. If enabled, disable it and see if the issue is resolved.
5. In **iDRAC Settings Utility**, ensure that **USB Management Port Mode** is configured as **Automatic** or **Standard OS Use**.
6. If the problem is not resolved, replace the keyboard and/or mouse with a known working keyboard or mouse.
If the problem is not resolved, proceed to step 7 to troubleshoot other USB devices attached to the system.
If the problem is not resolved, proceed to troubleshoot other USB devices attached to the system.
7. Turn off all attached USB devices, and disconnect them from the system.
8. Restart the system.
9. If your keyboard is functioning, enter System Setup, verify that all USB ports are enabled on the **Integrated Devices** screen. If your keyboard is not functioning, use remote access to enable or disable the USB options.
10. Check if USB 3.0 is enabled in System Setup. If it is enabled, disable it and restart your system.
11. If the system is not accessible, reset the NVRAM_CLR jumper inside your system and restore the BIOS to the default settings. See the System board jumper setting section
12. In the **iDRAC Settings Utility**, ensure that **USB Management Port Mode** is configured as **Automatic** or **Standard OS Use**.
13. Reconnect and turn on each USB device one at a time.
14. If a USB device causes the same problem, turn off the device, replace the USB cable with a known good cable, and turn on the device.

Next steps

If all troubleshooting fails, see the Getting help section.

Related references

[Getting help](#) on page 129

Troubleshooting iDRAC Direct (USB XML configuration)

For information about USB storage device and server configuration, see the Integrated Dell Remote Access Controller User's Guide at Dell.com/idracmanuals.

Steps

1. Ensure that your USB storage device is connected to the front USB Management Port, identified by  icon.
2. Ensure that your USB storage device is configured with an NTFS or an FAT32 file system with only one partition.
3. Verify that the USB storage device is configured correctly. For more information about configuring the USB storage device, see the Integrated Dell Remote Access Controller User's Guide at Dell.com/idracmanuals.
4. In the **iDRAC Settings Utility**, ensure that **USB Management Port Mode** is configured as **Automatic** or **iDRAC Direct Only**.
5. Ensure that the **iDRAC Managed: USB XML Configuration** option is either **Enabled** or **Enabled only when the server has default credential settings**.
6. Remove and reinsert the USB storage device.
7. If import operation does not work, try with a different USB storage device.

Next steps

If all troubleshooting fails, see the Getting help section.

Related references

[Getting help](#) on page 129

Troubleshooting iDRAC Direct (Laptop connection)

For information about USB laptop connection and server configuration, see the *Integrated Dell Remote Access Controller User's Guide* at Dell.com/idracmanuals.

Steps

1. Ensure that your laptop is connected to the front USB Management Port, identified by  icon with a USB Type A/A cable.
2. On the **iDRAC Settings Utility** screen, ensure that **USB Management Port Mode** is configured as **Automatic** or **iDRAC Direct Only**.
3. If the laptop is running Windows operating system, ensure that the iDRAC Virtual USB NIC device driver is installed.
4. If the driver is installed, ensure that you are not connected to any network through WiFi or cabled ethernet, as iDRAC Direct uses a non-routable address.

Next steps

If all troubleshooting fails, see the Getting help section.

Related references

[Getting help](#) on page 129

Troubleshooting a serial I/O device

Prerequisites

Steps

1. Turn off the system and any peripheral devices connected to the serial port.
2. Swap the serial interface cable with a known working cable, and turn on the system and the serial device.
If the problem is resolved, replace the interface cable with a known working cable.
3. Turn off the system and the serial device, and swap the serial device with a compatible device.
4. Turn on the system and the serial device.

Next steps

If the problem persists, see the Getting help section.

Related references

[Getting help](#) on page 129

Troubleshooting a NIC

Steps

1. Run the appropriate diagnostic test. For more information, see the Using system diagnostics section for the available diagnostic tests.
2. Restart the system and check for any system messages pertaining to the NIC controller.
3. Check the appropriate indicator on the NIC connector:
 - If the link indicator does not glow, the cable connected might be disengaged.
 - If the activity indicator does not glow, the network driver files might be damaged or missing.
Install or replace the drivers as necessary. For more information, see the NIC documentation.
 - Try another known good network cable.
 - If the problem persists, use another connector on the switch or hub.
4. Ensure that the appropriate drivers are installed and the protocols are bound. For more information, see the NIC documentation.
5. Enter System Setup and confirm that the NIC ports are enabled on the **Integrated Devices** screen.
6. Ensure that all the NICs, hubs, and switches on the network are set to the same data transmission speed and duplex. For more information, see the documentation for each network device.
7. Ensure that all the NICs and switches on the network are set to the same data transmission speed and duplex. For more information, see the documentation for each network device.
8. Ensure that all network cables are of the proper type and do not exceed the maximum length.

Next steps

If the problem persists, see the Getting help section.

Related references

[Using system diagnostics](#) on page 109

[Getting help](#) on page 129

Troubleshooting a wet system

Prerequisites

CAUTION: Many repairs may only be done by a certified service technician. You should only perform troubleshooting and simple repairs as authorized in your product documentation, or as directed by the online or telephone service and support team. Damage due to servicing that is not authorized by Dell is not covered by your warranty. Read and follow the safety instructions that are shipped with your product.

Steps

1. Turn off the system and attached peripherals, and disconnect the system from the electrical outlet.
2. Remove the system cover.
3. Remove the following components (if installed) from the system:

- Power supply unit(s)
- Optical drive
- Hard drives
- Hard drive backplane
- USB memory key
- Hard drive tray
- Cooling shroud
- Expansion card risers (if installed)
- Expansion cards
- Cooling fan assembly (if installed)
- Cooling fan(s)
- Memory modules
- Processor(s) and heat sink(s)
- System board

4. Let the system dry thoroughly for at least 24 hours.
5. Reinstall the components you removed in step 3 except the expansion cards.
6. Install the system cover.
7. Turn on the system and attached peripherals.

If the problem persists, see the Getting help section.

8. If the system starts properly, turn off the system, and reinstall all the expansion cards that you removed.
9. Run the appropriate diagnostic test. For more information, see the Using system diagnostics section.

Next steps

If the tests fail, see the Getting help section.

Related references

[Getting help](#) on page 129

[Using system diagnostics](#) on page 109

Troubleshooting a damaged system

Prerequisites

CAUTION: Many repairs may only be done by a certified service technician. You should only perform troubleshooting and simple repairs as authorized in your product documentation, or as directed by the online or telephone service and support team. Damage due to servicing that is not authorized by Dell is not covered by your warranty. Read and follow the safety instructions that are shipped with your product.

Steps

1. Turn off the system and attached peripherals, and disconnect the system from the electrical outlet.
2. Remove the system cover.
3. Ensure that the following components are properly installed:
 - cooling shroud
 - expansion card risers (if installed)
 - expansion cards
 - power supply unit(s)
 - cooling fan assembly (if installed)
 - cooling fan(s)
 - processor(s) and heat sink(s)
 - memory modules
 - hard-drive carriers or cage
 - hard drive backplane
4. Ensure that all cables are properly connected.
5. Install the system cover.
6. Run the appropriate diagnostic test. For more information, see the Using system diagnostics section.

Next steps

If the problem persists, see the Getting help section.

Related references

[Using system diagnostics](#) on page 109

[Getting help](#) on page 129

Troubleshooting the system battery

Prerequisites

CAUTION: Many repairs may only be done by a certified service technician. You should only perform troubleshooting and simple repairs as authorized in your product documentation, or as directed by the online or telephone service and support team. Damage due to servicing that is not authorized by Dell is not covered by your warranty. Read and follow the safety instructions that are shipped with your product.

NOTE: If the system is turned off for long periods of time (for weeks or months), the NVRAM may lose its system configuration information. This situation is caused by a defective battery.

NOTE: Some software may cause the system time to speed up or slow down. If the system seems to operate normally except for the time set in System Setup, the problem may be caused by a software, rather than by a defective battery.

Steps

1. Re-enter the time and date in System Setup.
2. Turn off the system, and disconnect it from the electrical outlet for at least an hour.
3. Reconnect the system to the electrical outlet, and turn on the system.
4. Enter System Setup.

If the date and time displayed in System Setup are not correct, check the System Error Log (SEL) for system battery messages.

Next steps

If the problem persists, see the Getting help section.

Related references

[Getting help](#) on page 129

Troubleshooting power supply units

Prerequisites

 **CAUTION:** Many repairs may only be done by a certified service technician. You should only perform troubleshooting and simple repairs as authorized in your product documentation, or as directed by the online or telephone service and support team. Damage due to servicing that is not authorized by Dell is not covered by your warranty. Read and follow the safety instructions that are shipped with your product.

The following sections provide information on troubleshooting power source and power supply units problems.

Troubleshooting power source problems

Steps

1. Press the power button to ensure that your system is turned on. If the power indicator does not glow when the power button is pressed, press the power button firmly.
2. Plug in another working power supply unit to ensure that the system board is not faulty.
3. Ensure that no loose connections exist.
For example, loose power cables.
4. Ensure that the power source meets applicable standards.
5. Ensure that there are no short circuits.
6. Have a qualified electrician check the line voltage to ensure that it meets the needed specifications.

Power supply unit problems

Steps

1. Ensure that no loose connections exist.
For example, loose power cables.
2. Ensure that the power supply unit (PSU) handle or LED indicates that the PSU is working properly.
For more information about PSU indicators, see the Power indicator codes section.
3. If you have recently upgraded your system, ensure that the PSU has enough power to support the new system.
4. If you have a redundant PSU configuration, ensure that both the PSUs are of the same type and wattage.
You may have to upgrade to a higher wattage PSU.
5. Ensure that you use only PSUs with the Extended Power Performance (EPP) label on the back.
6. Reseat the PSU.

 **NOTE:** After installing a PSU, allow several seconds for the system to recognize the PSU and determine if it is working properly.

If the problem persists, see the Getting help section.

Related references

[Getting help](#) on page 129

[Power supply unit indicator codes](#) on page 14

Troubleshooting cooling problems

CAUTION: Many repairs may only be done by a certified service technician. You should only perform troubleshooting and simple repairs as authorized in your product documentation, or as directed by the online or telephone service and support team. Damage due to servicing that is not authorized by Dell is not covered by your warranty. Read and follow the safety instructions that are shipped with your product.

Ensure that the following conditions exist:

- System cover, cooling shroud, EMI filler panel, memory module blank, or back filler bracket is not removed.
- Ambient temperature is not higher than the system specific ambient temperature.
- External airflow is not obstructed.
- A cooling fan is not removed or has not failed.
- The expansion card installation guidelines have been followed.

Additional cooling can be added by one of the following methods:

From the iDRAC web GUI:

1. Click **Hardware > Fans > Setup**.
2. From the **Fan Speed Offset** drop-down list, select the cooling level required or set the minimum fan speed to a custom value.

From F2 System Setup:

1. Select **iDRAC Settings > Thermal**, and set a higher fan speed from the fan speed offset or minimum fan speed.

From RACADM commands:

1. Run the command `racadm help system.thermalsettings`

For more information, see the Integrated Dell Remote Access User's Guide at Dell.com/idracmanuals.

Troubleshooting cooling fans

Prerequisites

CAUTION: Many repairs may only be done by a certified service technician. You should only perform troubleshooting and simple repairs as authorized in your product documentation, or as directed by the online or telephone service and support team. Damage due to servicing that is not authorized by Dell is not covered by your warranty. Read and follow the safety instructions that are shipped with your product.

NOTE: The fan number is referenced by the systems management software. In the event of a problem with a particular fan, you can easily identify and replace it by noting down the fan numbers on the cooling fan assembly.

1. Follow the safety guidelines listed in the Safety instructions section.
2. Follow the procedure listed in the Before working inside your system section.

Steps

1. Reseat the fan or the fan's power cable.
2. Restart the system.

Next steps

1. Follow the procedure listed in the After working inside your system section.
2. If the problem persists, see the Getting help section.

Related references

[Safety instructions](#) on page 48

[Getting help](#) on page 129

Related tasks

[Before working inside your system](#) on page 49

Troubleshooting system memory

Prerequisites

 **CAUTION:** Many repairs may only be done by a certified service technician. You should only perform troubleshooting and simple repairs as authorized in your product documentation, or as directed by the online or telephone service and support team. Damage due to servicing that is not authorized by Dell is not covered by your warranty. Read and follow the safety instructions that are shipped with your product.

Steps

1. If the system is operational, run the appropriate system diagnostic test. See the Using system diagnostics section for the available diagnostic tests.
If the diagnostic tests indicate a fault, follow the corrective actions provided by the diagnostic tests.
2. If the system is not operational, turn off the system and attached peripherals, and unplug the system from the power source. Wait at least for 10 seconds, and then reconnect the system to the power source.
3. Turn on the system and attached peripherals, and note the messages on the screen.
If an error message is displayed indicating a fault with a specific memory module, go to step 12.
4. Enter System Setup, and check the system memory setting. Make any changes to the memory settings, if needed.
If the memory settings match the installed memory but the problem still persists, go to step 12.
5. Turn off the system and attached peripherals, and disconnect the system from the electrical outlet.
6. Remove the system cover.
7. Check the memory channels and ensure that they are populated correctly.
 **NOTE:** See the system event log or system messages for the location of the failed memory module. Reinstall the memory device.
8. Reseat the memory modules in their sockets.
9. Install the system cover.
10. Enter System Setup and check the system memory setting.
If the problem is not resolved, proceed with step 11.
11. Remove the system cover.
12. If a diagnostic test or error message indicates a specific memory module as faulty, swap or replace the module with a known working memory module.
13. To troubleshoot an unspecified faulty memory module, replace the memory module in the first DIMM socket with a module of the same type and capacity.
If an error message is displayed on the screen, this may indicate a problem with the installed DIMM type(s), incorrect DIMM installation, or defective DIMM(s). Follow the on-screen instructions to resolve the problem.
14. Install the system cover.
15. As the system boots, observe any error message that is displayed and the diagnostic indicators on the front of the system.
16. If the memory problem persists, repeat step 12 through step 15 for each memory module installed.

Next steps

If the problem persists, see the Getting help section.

Related references

[Getting help](#) on page 129

[Using system diagnostics](#) on page 109

Troubleshooting an internal USB key

Prerequisites

 **CAUTION:** Many repairs may only be done by a certified service technician. You should only perform troubleshooting and simple repairs as authorized in your product documentation, or as directed by the online or telephone service and support team. Damage due to servicing that is not authorized by Dell is not covered by your warranty. Read and follow the safety instructions that are shipped with your product.

Steps

1. Enter System Setup and ensure that the **USB key port** is enabled on the **Integrated Devices** screen.
2. Turn off the system and attached peripherals, and disconnect the system from the electrical outlet.
3. Remove the system cover.
4. Locate the USB key and reseal it.
5. Install the system cover.
6. Turn on the system and attached peripherals, and check if the USB key is functioning.
7. If the problem is not resolved, repeat step 2 and step 3.
8. Insert a known working USB key.
9. Install the system cover.

Next steps

If the problem persists, see the Getting help section.

Related references

[Getting help](#) on page 129

Troubleshooting an optical drive

Prerequisites

 **CAUTION:** Many repairs may only be done by a certified service technician. You should only perform troubleshooting and simple repairs as authorized in your product documentation, or as directed by the online or telephone service and support team. Damage due to servicing that is not authorized by Dell is not covered by your warranty. Read and follow the safety instructions that are shipped with your product.

Steps

1. Try using a different CD or DVD.
2. If the problem is not resolved, enter System Setup and ensure that the integrated SATA controller and the drive's SATA port are enabled.
3. Run the appropriate diagnostic test.
4. Turn off the system and attached peripherals, and disconnect the system from the electrical outlet.
5. If installed, remove the bezel.
6. Remove the system cover.
7. Ensure that the interface cable is securely connected to the optical drive and to the controller.
8. Ensure that a power cable is properly connected to the drive.
9. Install the system cover.

Next steps

If the problem persists, see the Getting help section.

Related references

[Getting help](#) on page 129

Troubleshooting a tape backup unit

Prerequisites

 **CAUTION:** Many repairs may only be done by a certified service technician. You should only perform troubleshooting and simple repairs as authorized in your product documentation, or as directed by the online or telephone service and support team. Damage due to servicing that is not authorized by Dell is not covered by your warranty. Read and follow the safety instructions that are shipped with your product.

Steps

1. Use a different tape cartridge.
2. Ensure that the device drivers for the tape backup unit are installed and are configured correctly. See your tape drive documentation for more information about device drivers.
3. Reinstall the tape-backup software as instructed in the tape-backup software documentation.
4. Ensure that the interface cable of the tape drive is connected to the external port on the controller card.
5. Perform the following steps to ensure that the controller card is properly installed:
 - a. Turn off the system and attached peripherals, and disconnect the system from the electrical outlet.
 - b. Remove the system cover.
 - c. Reseat the controller card in the expansion card slot.
 - d. Install the system cover.
 - e. Turn on the system and attached peripherals.
6. Run the appropriate diagnostic test. For more information, see the Using system diagnostics.

Next steps

If you cannot resolve the problem, see the [Getting help](#) section.

Related references

[Getting help](#) on page 129

Troubleshooting a hard drive or SSD

Prerequisites

 **CAUTION:** This troubleshooting procedure can erase data stored on the hard drive. Before you proceed, back up all files on the hard drive.

 **CAUTION:** Many repairs may only be done by a certified service technician. You should only perform troubleshooting and simple repairs as authorized in your product documentation, or as directed by the online or telephone service and support team. Damage due to servicing that is not authorized by Dell is not covered by your warranty. Read and follow the safety instructions that are shipped with your product.

Steps

1. Run the appropriate diagnostic test. See the Using system diagnostics section.
Depending on the results of the diagnostics test, proceed as required through the following steps.
2. If your system has a RAID controller and your hard drives are configured in a RAID array, perform the following steps:
 - a. Restart the system and press F10 during system startup to run the Dell Lifecycle Controller, and then run the Hardware Configuration wizard to check the RAID configuration.
See the Dell Lifecycle Controller documentation or online help for information about RAID configuration.

- b. Ensure that the hard drives are configured correctly for the RAID array.
 - c. Take the hard drive offline and reseal the drive.
 - d. Exit the configuration utility and allow the system to boot to the operating system.
3. Ensure that the needed device drivers for your controller card are installed and are configured correctly. For more information, see the operating system documentation.
 4. Restart the system and enter the System Setup.
 5. Verify that the controller is enabled and the drives are displayed in the System Setup.

Next steps

If the problem persists, see the Getting help section.

Related references

[Getting help](#) on page 129

[Using system diagnostics](#) on page 109

Troubleshooting a storage controller

CAUTION: Many repairs may only be done by a certified service technician. You should only perform troubleshooting and simple repairs as authorized in your product documentation, or as directed by the online or telephone service and support team. Damage due to servicing that is not authorized by Dell is not covered by your warranty. Read and follow the safety instructions that are shipped with your product.

NOTE: When troubleshooting a SAS or PERC controller, see the documentation for your operating system and the controller.

1. Run the appropriate diagnostic test. See the Using system diagnostics section.
2. Turn off the system and attached peripherals, and disconnect the system from the electrical outlet.
3. Remove the system cover.
4. Verify that the installed expansion cards are compliant with the expansion card installation guidelines.
5. Ensure that each expansion card is firmly seated in its connector.
6. Install the system cover.
7. Reconnect the system to the electrical outlet, and turn on the system and attached peripherals.
8. If the problem is not resolved, turn off the system and attached peripherals, and disconnect the system from the electrical outlet.
9. Remove the system cover.
10. Remove all expansion cards installed in the system.
11. Install the system cover.
12. Reconnect the system to the electrical outlet, and turn on the system and attached peripherals.
13. Run the appropriate diagnostic test. See the Using system diagnostics section. If the tests fail, see the Getting help section.
14. For each expansion card you removed in step 10, perform the following steps:
 - a. Turn off the system and attached peripherals, and disconnect the system from the electrical outlet.
 - b. Remove the system cover.
 - c. Reinstall one of the expansion cards.
 - d. Install the system cover.
 - e. Run the appropriate diagnostic test. See the Using system diagnostics section.

If the problem persists, see the Getting help section.

Related references

[Using system diagnostics](#) on page 109

[Getting help](#) on page 129

Troubleshooting expansion cards

Prerequisites

 **CAUTION:** Many repairs may only be done by a certified service technician. You should only perform troubleshooting and simple repairs as authorized in your product documentation, or as directed by the online or telephone service and support team. Damage due to servicing that is not authorized by Dell is not covered by your warranty. Read and follow the safety instructions that are shipped with your product.

 **NOTE:** When troubleshooting an expansion card, you also have to see the documentation for your operating system and the expansion card.

Steps

1. Run the appropriate diagnostic test. See the Using system diagnostics section.
2. Turn off the system and attached peripherals, and disconnect the system from the electrical outlet.
3. Remove the system cover.
4. Ensure that each expansion card is firmly seated in its connector.
5. Install the system cover.
6. Turn on the system and attached peripherals.
7. If the problem is not resolved, turn off the system and attached peripherals, and disconnect the system from the electrical outlet.
8. Remove the system cover.
9. Remove all expansion cards installed in the system.
10. Install the system cover.
11. Run the appropriate diagnostic test. See the Using system diagnostics section.
If the tests fail, see the Getting help section.
12. For each expansion card you removed in step 8, perform the following steps:
 - a. Turn off the system and attached peripherals, and disconnect the system from the electrical outlet.
 - b. Remove the system cover.
 - c. Reinstall one of the expansion cards.
 - d. Install the system cover.
 - e. Run the appropriate diagnostic test. See the Using system diagnostics section.

Next steps

If the problem persists, see the Getting help section.

Related references

[Using system diagnostics](#) on page 109

[Getting help](#) on page 129

Troubleshooting processors

Prerequisites

 **CAUTION:** Many repairs may only be done by a certified service technician. You should only perform troubleshooting and simple repairs as authorized in your product documentation, or as directed by the online or telephone service and support team. Damage due to servicing that is not authorized by Dell is not covered by your warranty. Read and follow the safety instructions that are shipped with your product.

Steps

1. Run the appropriate diagnostics test. See the Using system diagnostics section.

2. Turn off the system and attached peripherals, and disconnect the system from the electrical outlet.
3. Remove the system cover.
4. Ensure that the processor and heat sink are properly installed.
5. Install the system cover.
6. Run the appropriate diagnostic test. See the Using system diagnostics section.
7. If the problem persists, see the Getting help section.

Related references

[Getting help](#) on page 129

[Using system diagnostics](#) on page 109

System messages

For a list of event and error messages generated by the system firmware and agents that monitor system components, see the Dell Event and Error Messages Reference Guide at [Dell.com/openmanagemanuals](https://www.dell.com/openmanagemanuals) > **OpenManage software**.

Warning messages

A warning message alerts you to a possible problem and prompts you to respond before the system continues a task. For example, before you format a hard drive, a message warns you that you may lose all data on the hard drive. Warning messages usually interrupt the task and need you to respond by typing y (yes) or n (no).

 **NOTE:** Warning messages are generated by either the application or the operating system. For more information, see the documentation that shipped with the operating system or application.

Diagnostic messages

The system diagnostic utility generates messages if there are errors detected when you run diagnostic tests on your system. For more information about system diagnostics, see the Using system diagnostics section.

Related references

[Using system diagnostics](#) on page 109

Alert messages

The systems management software generates alert messages for your system. Alert messages include information, status, warning, and failure messages for drive, temperature, fan, and power conditions. For more information, see the systems management software documentation links listed in the Documentation resources section of this manual.

Related references

[Documentation resources](#) on page 17

Getting help

Topics:

- [Contacting Dell](#)
- [Documentation feedback](#)
- [Quick Resource Locator](#)

Contacting Dell

Dell provides several online and telephone-based support and service options. If you do not have an active Internet connection, you can find contact information on your purchase invoice, packing slip, bill, or Dell product catalog. Availability varies by country and product, and some services may not be available in your area. To contact Dell for sales, technical support, or customer-service issues:

Steps

1. Go to **dell.com/support**.
2. Select your country from the drop-down menu on the bottom right corner of the page.
3. For customized support:
 - a. Enter your system Service Tag in the **Enter your Service Tag** field.
 - b. Click **Submit**.
The support page that lists the various support categories is displayed.
4. For general support:
 - a. Select your product category.
 - b. Select your product segment.
 - c. Select your product.
The support page that lists the various support categories is displayed.

Documentation feedback

If you have feedback for this document, write to **documentation_feedback@dell.com**. Alternatively, you can click on the **Feedback** link in any of the Dell documentation pages, fill out the form, and click **Submit** to send your feedback.

Quick Resource Locator

Use the Quick Resource Locator (QRL) to get immediate access to system information and how-to videos. This can be done by visiting **Dell.com/QRL** or by using your smartphone or tablet and a model-specific Quick Resource (QR) code located on your Dell Storage system. To try out the QR code, scan the following image:



Figure 48. Quick resource locator