

# Dell SD630-S—Storage Designed for Scalify RING Owner's Manual

## Notes, cautions, and warnings

 **NOTE:** A NOTE indicates important information that helps you make better use of your computer.

 **CAUTION:** A CAUTION indicates either potential damage to hardware or loss of data and tells you how to avoid the problem.

 **WARNING:** A WARNING indicates a potential for property damage, personal injury, or death.

<b>Chapter 1: Dell SD630-S overview</b>	<b>7</b>
Supported configurations	7
Front panel	7
Eight x 2.5-inch hard drive chassis	7
LCD panel	9
Back panel	11
Two-riser chassis	11
Hard drive indicator codes	13
iDRAC Direct LED indicator codes	13
NIC indicator codes	15
Power supply unit indicator codes	15
Quick Sync indicator codes	18
Locating Service Tag of your system	18
<b>Chapter 2: Documentation resources</b>	<b>19</b>
<b>Chapter 3: Technical specifications</b>	<b>20</b>
Chassis dimensions	20
Chassis weight	21
Processor specifications	21
PSU specifications	21
System battery specifications	21
Expansion bus specifications	22
Memory specifications	22
Drive specifications	22
Hard drives	22
Optical drive	22
Ports and connectors specifications	23
USB ports	23
NIC ports	23
Serial connector	23
VGA ports	23
Video specifications	23
Environmental specifications	24
Particulate and gaseous contamination specifications	25
Standard operating temperature	25
Expanded operating temperature	26
Expanded operating temperature restrictions	26
<b>Chapter 4: Initial system setup and configuration</b>	<b>27</b>
Setting up your system	27
iDRAC configuration	27
Options to set up iDRAC IP address	27
Log in to iDRAC	28

Options to install the operating system.....	28
Methods to download firmware and drivers.....	28
Manage your system.....	29
<b>Chapter 5: Pre-operating system management applications.....</b>	<b>30</b>
Options to manage the pre-operating system applications.....	30
System Setup.....	30
Viewing System Setup.....	31
System Setup details.....	31
System BIOS.....	31
iDRAC Settings utility.....	55
Device Settings.....	56
Dell Lifecycle Controller.....	56
Embedded system management.....	56
Boot Manager.....	56
Viewing Boot Manager.....	57
Boot Manager main menu.....	57
PXE boot.....	58
<b>Chapter 6: Installing and removing system components.....</b>	<b>59</b>
Safety instructions.....	59
Before working inside your system.....	60
After working inside your system.....	60
Recommended tools.....	60
Front bezel (optional).....	61
Removing the optional front bezel.....	61
Installing the optional front bezel.....	62
Removing the system cover.....	63
Installing the system cover.....	64
Inside the system.....	65
Cooling shroud.....	67
Removing the cooling shroud.....	67
Installing the cooling shroud.....	67
System memory.....	68
General memory module installation guidelines.....	70
Mode-specific guidelines.....	70
Sample memory configurations.....	71
Removing memory modules.....	73
Installing memory modules.....	74
Hard drives.....	76
Removing a 2.5-inch hard drive blank.....	76
Installing a 2.5-inch hard drive blank.....	77
Removing a hot swappable hard drive or SSD.....	78
Installing a hot swappable hard drive.....	79
Removing a hard drive from a hard drive carrier.....	80
Installing a hot swappable hard drive into a hot swappable hard drive carrier.....	80
Optical drive (optional).....	81
Removing the optional optical drive.....	81
Installing the optional optical drive.....	82

Removing the slim optical drive blank.....	83
Installing the slim optical drive blank.....	84
Cooling fans.....	85
Removing a cooling fan.....	85
Installing a cooling fan.....	86
Internal USB memory key (optional).....	87
Replacing the optional internal USB memory key.....	87
Expansion cards and expansion card riser.....	89
Expansion card installation guidelines.....	89
Removing an expansion card.....	90
Installing an expansion card.....	91
Removing expansion card risers.....	92
Installing expansion card risers.....	93
SD vFlash media card (optional).....	95
Replacing an SD vFlash card.....	95
Integrated storage controller card.....	96
Removing the integrated storage controller card.....	96
Installing the integrated storage controller card.....	97
Network daughter card.....	99
Removing the network daughter card.....	99
Installing the network daughter card.....	100
Processors and heat sinks.....	101
Removing a processor.....	102
Installing a processor.....	104
Power supply units.....	106
Hot spare feature.....	106
Removing the power supply unit blank.....	106
Installing the power supply unit blank.....	107
Removing an AC power supply unit.....	107
Installing an AC power supply unit.....	108
Wiring instructions for a DC power supply unit.....	109
Removing a DC power supply unit.....	110
Installing a DC power supply unit.....	111
System battery.....	112
Replacing the system battery.....	112
Hard drive backplane.....	113
Removing the hard drive backplane.....	113
Installing the hard drive backplane.....	115
Control panel assembly.....	116
Removing the control panel board–eight hard drive system.....	116
Installing the control panel board–eight hard drive system.....	117
VGA module.....	118
Removing the VGA module.....	119
Installing the VGA module.....	120
System board.....	121
Removing the system board.....	121
Installing the system board.....	123
Trusted Platform Module.....	126
Installing the Trusted Platform Module.....	126
Initializing the TPM for BitLocker users.....	127

Initializing the TPM for TXT users.....	127
<b>Chapter 7: Using system diagnostics.....</b>	<b>128</b>
Dell Embedded System Diagnostics.....	128
When to use the Embedded System Diagnostics.....	128
Running the Embedded System Diagnostics from Boot Manager.....	128
Running the Embedded System Diagnostics from the Dell Lifecycle Controller.....	128
System diagnostic controls.....	129
<b>Chapter 8: Jumpers and connectors .....</b>	<b>130</b>
System board jumper settings.....	130
System board jumpers and connectors.....	131
Disabling a forgotten password.....	133
<b>Chapter 9: Troubleshooting your system.....</b>	<b>134</b>
Troubleshooting system startup failure.....	134
Troubleshooting external connections.....	134
Troubleshooting the video subsystem.....	135
Troubleshooting a USB device.....	135
Troubleshooting iDRAC Direct (USB XML configuration).....	136
Troubleshooting iDRAC Direct (Laptop connection).....	136
Troubleshooting a serial I/O device.....	137
Troubleshooting a NIC.....	137
Troubleshooting a wet system.....	137
Troubleshooting a damaged system.....	138
Troubleshooting the system battery.....	139
Troubleshooting power supply units.....	139
Troubleshooting power source problems.....	140
Power supply unit problems.....	140
Troubleshooting cooling problems.....	140
Troubleshooting cooling fans.....	141
Troubleshooting system memory.....	141
Troubleshooting an internal USB key.....	142
Troubleshooting an optical drive.....	143
Troubleshooting a tape backup unit.....	143
Troubleshooting a hard drive.....	144
Troubleshooting a storage controller.....	145
Troubleshooting expansion cards.....	145
Troubleshooting processors.....	146
<b>Chapter 10: Getting help.....</b>	<b>147</b>
Contacting Dell.....	147
Documentation feedback.....	147
Quick resource locator.....	147

## Dell SD630-S overview

The Dell SD630-S—Storage Designed for Scalacity RING is a storage platform that supports:

- One or two processors based on the Intel Xeon E5-2600 v3 and v4 processor family
- 24 DIMMs
- Storage capacity of up to eight drive slots

**NOTE:** The Dell SD630-S system supports only internal, hot-swappable hard drives.

If the Dell SD630-S system is configured as Admin system then Intel Xeon E5-2630 or higher processor is supported.

If the Dell SD630-S system is configured as Connector system then Intel Xeon E5-2630 or higher dual processor is supported.

### Topics:

- [Supported configurations](#)
- [Front panel](#)
- [Back panel](#)
- [Hard drive indicator codes](#)
- [iDRAC Direct LED indicator codes](#)
- [NIC indicator codes](#)
- [Power supply unit indicator codes](#)
- [Quick Sync indicator codes](#)
- [Locating Service Tag of your system](#)

## Supported configurations

The Dell SD630-S system is a storage server based on R630 chassis platform with eight hard drive system configuration.

## Front panel

### Eight x 2.5-inch hard drive chassis

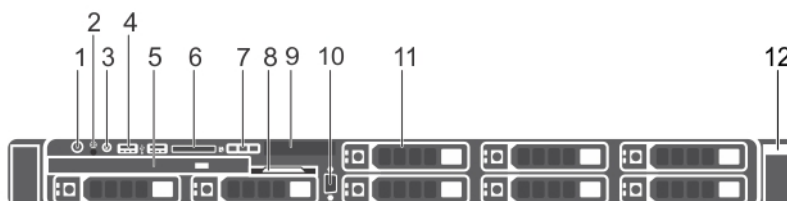





**Figure 1. Front panel features of the eight x 2.5-inch Dell SD630-S hard drive chassis**

- |                                     |  |
|-------------------------------------|--|
| 1. Power-on indicator, power button | 2. NMI button                              |
| 3. System identification button     | 4. USB management port or iDRAC Direct (2) |
| 5. Optical drive (optional)         | 6. SD vFlash media card slot               |
| 7. LCD menu buttons                 | 8. Information tag                         |

- 9. LCD panel
- 11. Hard drives (8)

- 10. Video connector
- 12. Quick Sync

**Table 1. Front panel features of the eight x 2.5-inch Dell SD630-S hard drive chassis**

Item	Indicator, Button, or Connector	Icon	Description
1	Power-on indicator, power button		Enables you to know the power status of the system. The power indicator turns on when the system power is on. The power button controls the power supply output to the system. <b>NOTE:</b> On Advanced Configuration and Power Interface (ACPI)-compliant operating systems, turning off the system by using the power button causes the system to perform a graceful shutdown before power to the system is turned off.
2	NMI button		Enables you to troubleshoot software and device driver errors when running certain operating systems. This button can be pressed by using the end of a paper clip. <b>NOTE:</b> Use this button only if directed to do so by qualified support personnel or by the operating system documentation.
3	System identification button		Enables you to locate a particular system within a rack. The identification buttons are on the front and back panels. When one of these buttons is pressed, the LCD panel on the front and the system status indicator on the back flash until one of the buttons is pressed again.  To turn the system ID on or off, press the system identification button.  If the system stops responding during POST, press and hold the system ID button for more than five seconds to enter BIOS progress mode.  To reset the iDRAC (if not disabled in F2 iDRAC setup), press and hold the button for more than 15 seconds.
4	USB management port/iDRAC Direct (2)		Functions as a regular USB port or provides access to the iDRAC Direct features. For more information, see the iDRAC Guide at <a href="http://Dell.com/idracmanuals">Dell.com/idracmanuals</a> .  The ports are USB 3.0-compliant.
5	Optical drive (optional)		One optional SATA DVD-ROM drive or DVD+/-RW drive. <b>NOTE:</b> DVD devices are data only.
6	SD vFlash media card slot		Enables you to insert a vFlash media card.
7	LCD menu buttons		Enables you to navigate the control panel LCD menu.
8	Information tag		Contains system information such as service tag, NIC, MAC address for your reference. The information tag is a slide-out label panel.
9	LCD panel		Displays system ID, status information, and system error messages. The LCD turns blue during normal system operation. When the system needs attention, the LCD turns amber and the LCD panel displays an error code followed by descriptive text. <b>NOTE:</b> If the system is connected to AC power and an error is detected, the LCD turns amber regardless of whether the system is turned on or off.

**Table 1. Front panel features of the eight x 2.5-inch Dell SD630-S hard drive chassis (continued)**

Item	Indicator, Button, or Connector	Icon	Description
10	Video connector		Enables you to connect a VGA display to the system.
11	Hard drives (8)		Up to eight 2.5-inch hot swappable hard drives.
12.	Quick Sync		Indicates a Quick Sync enabled system. The Quick Sync feature is optional and needs a Quick Sync bezel. This feature allows management of the system by using mobile devices. This feature aggregates hardware or firmware inventory and various system level diagnostic and error information that can be used in troubleshooting the system. For more information, see the Integrated Dell Remote Access Controller User's Guide at <a href="http://Dell.com/idracmanuals">Dell.com/idracmanuals</a> .

**Related references**

[Expansion card installation guidelines](#) on page 89

## LCD panel

The LCD panel of your system provides system information, status, and error messages to indicate if the system is functioning correctly or if the system needs attention. For more information about error messages, see the *Dell Event and Error Messages Reference Guide* at [Dell.com/openmanagemanuals](http://Dell.com/openmanagemanuals) > **OpenManage software**.

- The LCD backlight turns blue during normal operating conditions.
- When the system needs attention, the LCD turns amber, and displays an error code followed by descriptive text.
  - i NOTE:** If the system is connected to a power source and an error is detected, the LCD turns amber regardless of whether the system is turned on or off.
- The LCD backlight is turned off when the system is in standby mode and can be turned on by pressing either the Select, Left, or Right button on the LCD panel.
- The LCD backlight remains off if LCD messaging is turned off using the iDRAC utility, the LCD panel, or other tools.

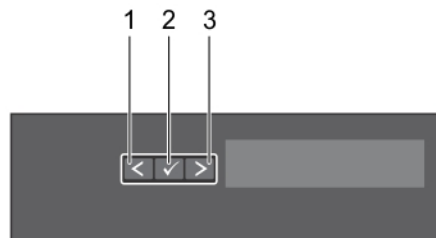

**Figure 2. LCD panel features**

**Table 2. LCD panel features**



Item	Button	Description
1	Left	Moves the cursor back in one-step increments.
2	Select	Selects the menu item highlighted by the cursor.
3	Right	<p>Moves the cursor forward in one-step increments.</p> <p>During message scrolling:</p> <ul style="list-style-type: none"> <li>• Press and hold the button to increase scrolling speed.</li> <li>• Release the button to stop.</li> </ul> <p><b>i NOTE:</b> The display stops scrolling when the button is released. After 45 seconds of inactivity the display starts scrolling.</p>

## Viewing Home screen

### About this task

The **Home** screen displays user-configurable information about the system. This screen is displayed during normal system operation when there are no status messages or errors. When the system is in standby mode, the LCD backlight turns off after a few minutes of inactivity, if there are no error messages.

### Steps

1. To view the **Home** screen, press one of the three navigation buttons (Select, Left, or Right).
2. To navigate to the **Home** screen from another menu, complete the following steps:
  - a. Press and hold the up arrow  until the **Home** icon  is displayed.
  - b. Select the **Home** icon.
  - c. On the **Home** screen, press the **Select** button to enter the main menu.

## Setup menu

 **NOTE:** When you select an option in the Setup menu, you must confirm the option before proceeding to the next action.

Option	Description
<b>iDRAC</b>	Select <b>DHCP</b> or <b>Static IP</b> to configure the network mode. If <b>Static IP</b> is selected, the available fields are <b>IP</b> , <b>Subnet (Sub)</b> , and <b>Gateway (Gtw)</b> . Select <b>Setup DNS</b> to enable DNS and to view domain addresses. Two separate DNS entries are available.
<b>Set error</b>	Select <b>SEL</b> to view LCD error messages in a format that matches the IPMI description in the SEL. This enables you to match an LCD message with an SEL entry.  Select <b>Simple</b> to view LCD error messages in a simplified user-friendly description. For more information about error messages, see the <i>Dell Event and Error Messages Reference Guide</i> at <a href="https://www.dell.com/support/manuals">Dell.com/openmanagemanuals</a> > <b>OpenManage software</b> .
<b>Set home</b>	Select the default information to be displayed on the <b>Home</b> screen. See View menu section for the options and option items that can be set as the default on the <b>Home</b> screen.

## View menu

 **NOTE:** When you select an option in the View menu, you must confirm the option before proceeding to the next action.

Option	Description
<b>iDRAC IP</b>	Displays the <b>IPv4</b> or <b>IPv6</b> addresses for iDRAC8. Addresses include <b>DNS (Primary and Secondary)</b> , <b>Gateway</b> , <b>IP</b> , and <b>Subnet</b> (IPv6 does not have Subnet).
<b>MAC</b>	Displays the MAC addresses for <b>iDRAC</b> , <b>iSCSI</b> , or <b>Network</b> devices.
<b>Name</b>	Displays the name of the <b>Host</b> , <b>Model</b> , or <b>User String</b> for the system.
<b>Number</b>	Displays the <b>Asset tag</b> or the <b>Service tag</b> for the system.
<b>Power</b>	Displays the power output of the system in BTU/hr or Watts. The display format can be configured in the <b>Set home</b> submenu of the <b>Setup</b> menu.
<b>Temperature</b>	Displays the temperature of the system in Celsius or Fahrenheit. The display format can be configured in the <b>Set home</b> submenu of the <b>Setup</b> menu.

# Back panel

## Two-riser chassis

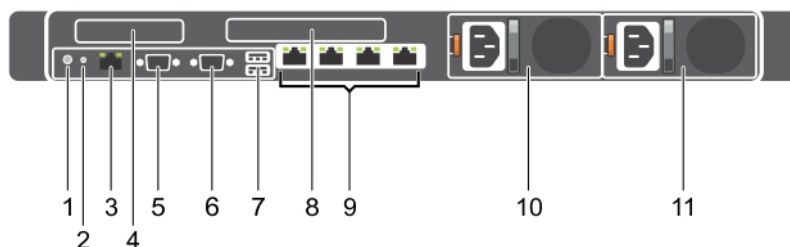

**Figure 3. Back panel features (two PCIe expansion cards)**

- |                                 |                                       |
|---------------------------------|---------------------------------------|
| 1. System identification button | 2. System identification connector    |
| 3. iDRAC8 Enterprise port       | 4. PCIe expansion card slot (riser 1) |
| 5. Serial connector             | 6. Video connector                    |
| 7. USB ports (2)                | 8. PCIe expansion card slot (riser 2) |
| 9. Ethernet connectors (4)      | 10. Power supply unit (PSU1)          |
| 11. Power supply unit (PSU2)    |                                       |

**Table 3. Back panel features (two PCIe expansion cards)**

Item	Indicator, Button, or Connector	Icon	Description
1	System identification button		<p>The identification buttons on the front and back panels can be used to locate a particular system within a rack. When one of these buttons is pressed, the LCD panel on the front and the system status indicator on the back flash until one of the buttons is pressed again.</p> <p>Press to toggle the system ID on and off. If the system stops responding during POST, press and hold the system ID button for more than five seconds to enter BIOS progress mode.</p> <p>To reset iDRAC (if not disabled in F2 iDRAC setup), press and hold for more than 15 seconds.</p>
2	System identification connector		Enables you to connect the optional system status indicator assembly through the optional cable management arm.
3	iDRAC8 Enterprise port		<p>Dedicated management port.</p> <p><b>NOTE:</b> The port is available for use only if the iDRAC8 Enterprise license is installed on your system.</p>
4	PCIe expansion card slot (riser 1)		Enables you to connect a low profile PCIe expansion card. See the Expansion card installation guidelines section.
5	Serial connector		Enables you to connect a serial device to the system.
6	Video connector		Enables you to connect a VGA display to the system.
7	USB ports (2)		Enables you to connect USB devices to the system. The ports are USB 3.0-compliant.
8	PCIe expansion card slot (riser 2)		Enables you to connect a full height three-fourth length PCIe expansion card. See the Expansion card installation guidelines section.

**Table 3. Back panel features (two PCIe expansion cards) (continued)**

Item	Indicator, Button, or Connector	Icon	Description
9	Ethernet connectors (4)		Four integrated 10/100/1000 Mbps NIC connectors or Four integrated connectors: <ul style="list-style-type: none"><li>• Two integrated 10/100/1000 Mbps NIC connectors</li><li>• Two integrated 100 Mbps/1 Gbps/10 Gbps SFP+ connectors</li></ul> or <ul style="list-style-type: none"><li>• Four 10 Gbps</li></ul>
10	PSU1		<ul style="list-style-type: none"><li>• Two 495 W, 750 W, or 1100 W AC power supply units (PSUs)</li></ul> Or <ul style="list-style-type: none"><li>• Two 1100 W DC PSUs</li></ul> Or <ul style="list-style-type: none"><li>• Two 750 W mixed mode PSUs</li></ul>
11	PSU2		<ul style="list-style-type: none"><li>• Two 495 W, 750 W, or 1100 W AC PSUs</li></ul> Or <ul style="list-style-type: none"><li>• Two 1100 W DC PSUs</li></ul> Or <ul style="list-style-type: none"><li>• Two 750 W mixed mode PSUs</li></ul>

**Related references**

[Expansion card installation guidelines](#) on page 89

## Hard drive indicator codes

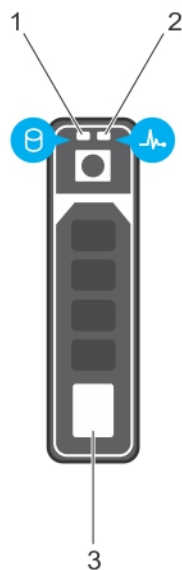

**Figure 4. Hard drive indicators**

1. hard drive activity indicator
2. hard drive status indicator
3. hard drive

**NOTE:** If the hard drive is in the Advanced Host Controller Interface (AHCI) mode, the status indicator (on the right side) does not function and remains off.

**Table 4. Hard drive indicator codes**

Drive-status indicator pattern (RAID only)	Condition
Flashes green twice per second	Identifying drive or preparing for removal.
Off	Drive ready for insertion or removal. <b>NOTE:</b> The drive status indicator remains off until all hard drives are initialized after the system is turned on. Drives are not ready for insertion or removal during this time.
Flashes green, amber, and turns off	Predicted drive failure
Flashes amber four times per second	Drive failed
Flashes green slowly	Drive rebuilding
Steady green	Drive online
Flashes green for three seconds, amber for three seconds, and turns off after six seconds	Rebuild stopped

## iDRAC Direct LED indicator codes

**NOTE:** The iDRAC Direct LED indicator does not turn on when the USB port is used in the USB mode.



**Figure 5. iDRAC Direct LED indicator**

1. iDRAC Direct status indicator

The iDRAC Direct LED indicator table describes iDRAC Direct activity when configuring iDRAC Direct by using the management port (USB XML Import).

**Table 5. iDRAC Direct LED indicators**

Convention	iDRAC Direct LED indicator pattern	Condition
A	Green	Turns green for a minimum of two seconds to indicate the start and end of a file transfer.
B	Flashing green	Indicates file transfer or any operation tasks.
C	Green and turns off	Indicates that the file transfer is complete.
D	Not lit	Indicates that the USB is ready to be removed or that a task is complete.

The following table describes iDRAC Direct activity when configuring iDRAC Direct by using your laptop and cable (Laptop Connect):

**Table 6. iDRAC Direct LED indicator patterns**

iDRAC Direct LED indicator pattern	Condition
Solid green for two seconds	Indicates that the laptop is connected.
Flashing green (on for two seconds and off for two seconds)	Indicates that the laptop connected is recognized.
Turns off	Indicates that the laptop is unplugged.

# NIC indicator codes

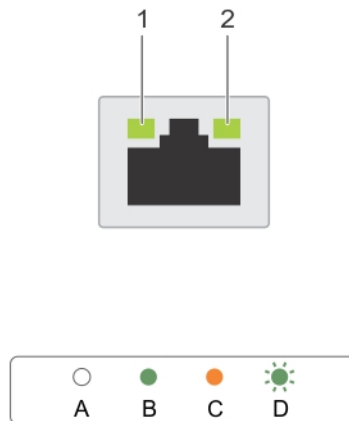

**Figure 6. NIC indicators**

1. link indicator
2. activity indicator

**Table 7. NIC indicators**

Convention	Status	Condition
A	Link and activity indicators are off	The NIC is not connected to the network.
B	Link indicator is green	The NIC is connected to a valid network at its maximum port speed (1 Gbps or 10 Gbps).
C	Link indicator is amber	The NIC is connected to a valid network at less than its maximum port speed.
D	Activity indicator is flashing green	Network data is being sent or received.

# Power supply unit indicator codes

AC power supply units (PSUs) have an illuminated translucent handle that serves as an indicator and DC PSUs have an LED that serves as an indicator. The indicator shows whether power is present or a power fault has occurred.

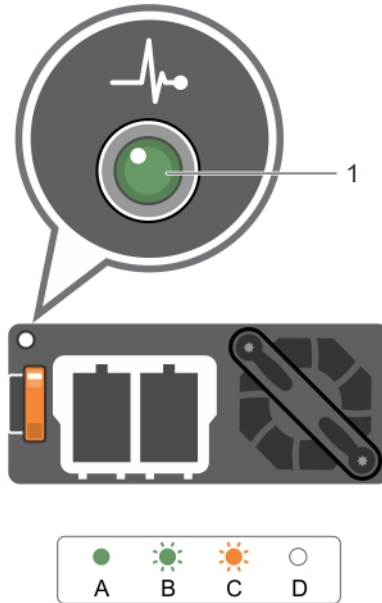

**Figure 7. AC PSU status indicator**

1. AC PSU status indicator/handle

**Table 8. AC PSU status indicators**

Convention	Power indicator pattern	Condition
A	Green	A valid power source is connected to the PSU and the PSU is operational.
B	Flashing green	When the firmware of the PSU is being updated, the PSU handle flashes green.
C	Flashing green and turns off	When hot-adding a PSU, the PSU handle flashes green five times at 4 Hz rate and turns off. This indicates a PSU mismatch with respect to efficiency, feature set, health status, and supported voltage. <b>NOTE:</b> Ensure that both the PSUs are of the same capacity. <b>CAUTION:</b> For AC PSUs, use only PSUs with the Extended Power Performance (EPP) label on the back.
D	Flashing amber	Indicates a problem with the PSU. <b>CAUTION:</b> When correcting a PSU mismatch, replace only the PSU with the flashing indicator. Swapping the PSU to make a matched pair can result in an error condition and unexpected system shutdown. To change from a high output configuration to a low output configuration or vice versa, you must power down the system. <b>CAUTION:</b> AC PSUs support both 220 V and 110 V input voltages with the exception of Titanium PSUs, which support only 220 V. When two identical PSUs receive different input voltages, they can output different wattages, and trigger a mismatch. <b>CAUTION:</b> If two PSUs are used, they must be of the same type and have the same maximum output power. <b>CAUTION:</b> Combining AC and DC PSUs is not supported and triggers a mismatch.
E	Not lit	Power is not connected.



**Figure 8. DC PSU status indicator**

1. DC PSU status indicator

**Table 9. DC PSU status indicators**

Convention	Power indicator pattern	Condition
A	Green	A valid power source is connected to the PSU and that the PSU is operational.
B	Flashing green	When hot-adding a PSU, the PSU indicator flashes green. This indicates that there is a PSU mismatch with respect to efficiency, feature set, health status, and supported voltage. Ensure that both the PSUs are of the same capacity.
C	Flashing amber	Indicates a problem with the PSU. ⚠️ <b>CAUTION: When correcting a PSU mismatch, replace only the PSU with the flashing indicator. Swapping the PSU to make a matched pair can result in an error condition and unexpected system shutdown. To change from a High Output configuration to a Low Output configuration or vice versa, you must power down the system.</b> ⚠️ <b>CAUTION: AC PSU support both 220 V and 110 V input voltages with the exception of Titanium PSU, which support only 220 V. When two identical PSU receive different input voltages, they can output different wattages, and trigger a mismatch.</b> ⚠️ <b>CAUTION: If two PSU are used, they must be of the same type and have the same maximum output power.</b> ⚠️ <b>CAUTION: Combining AC and DC PSU is not supported and triggers a mismatch.</b>
D	Not lit	Power is not connected.

# Quick Sync indicator codes

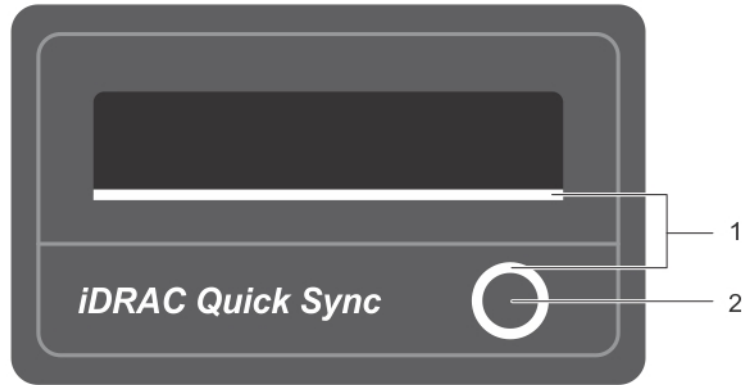

**Figure 9. Quick Sync indicator codes**

1. Quick Sync status indicator
2. Quick Sync activation button

**Table 10. Quick Sync indicator codes**

Power indicator pattern	Condition
Slow flash	Indicates that Quick Sync is waiting to be configured from iDRAC.
Solid	Indicates that Quick Sync is ready to transfer.
Flashes three times rapidly and then turns off	Indicates that the Quick Sync feature is disabled from iDRAC.
Flashes continuously when the mobile device touches the antenna	Indicates data transfer activity.
Flashes rapidly five times and turns off for one second when the activation button is pressed. This pattern is repeated until the activation button is pressed again.	Indicates that the Quick Sync hardware is not responding properly. Reseat the bezel. If the problem persists, see Getting help section.
Off	Indicates that the Quick Sync feature is turned off. Use the activation button to enable it. If pressing the activation button does not turn on the LEDs, it indicates that power is not delivered to the Quick Sync bezel.
	<p><b>NOTE:</b> For security purposes, Quick Sync turns off after 30 seconds of inactivity after the activation button is pressed. After timed-out, the user is expected to press the activation button again to activate Quick Sync.</p>

**Related references**

[Getting help](#) on page 147

## Locating Service Tag of your system

Your system is identified by a unique Express Service Code and Service Tag number. The Express Service Code and Service Tag are found on the front of the system by pulling out the information tag. Alternatively, the information may be on a sticker on the chassis of the system. This information is used by Dell to route support calls to the appropriate personnel.

## Documentation resources

For information about Dell documentation and Scality documentation, see the *Dell Storage Designed for Scality RING Support Matrix* available at [Dell.com/sdscalityseriesmanuals](https://www.dell.com/sdscalityseriesmanuals).

## Technical specifications

The technical and environmental specifications of your system are outlined in this section.

### Topics:

- Chassis dimensions
- Chassis weight
- Processor specifications
- PSU specifications
- System battery specifications
- Expansion bus specifications
- Memory specifications
- Drive specifications
- Ports and connectors specifications
- Video specifications
- Environmental specifications

### Chassis dimensions

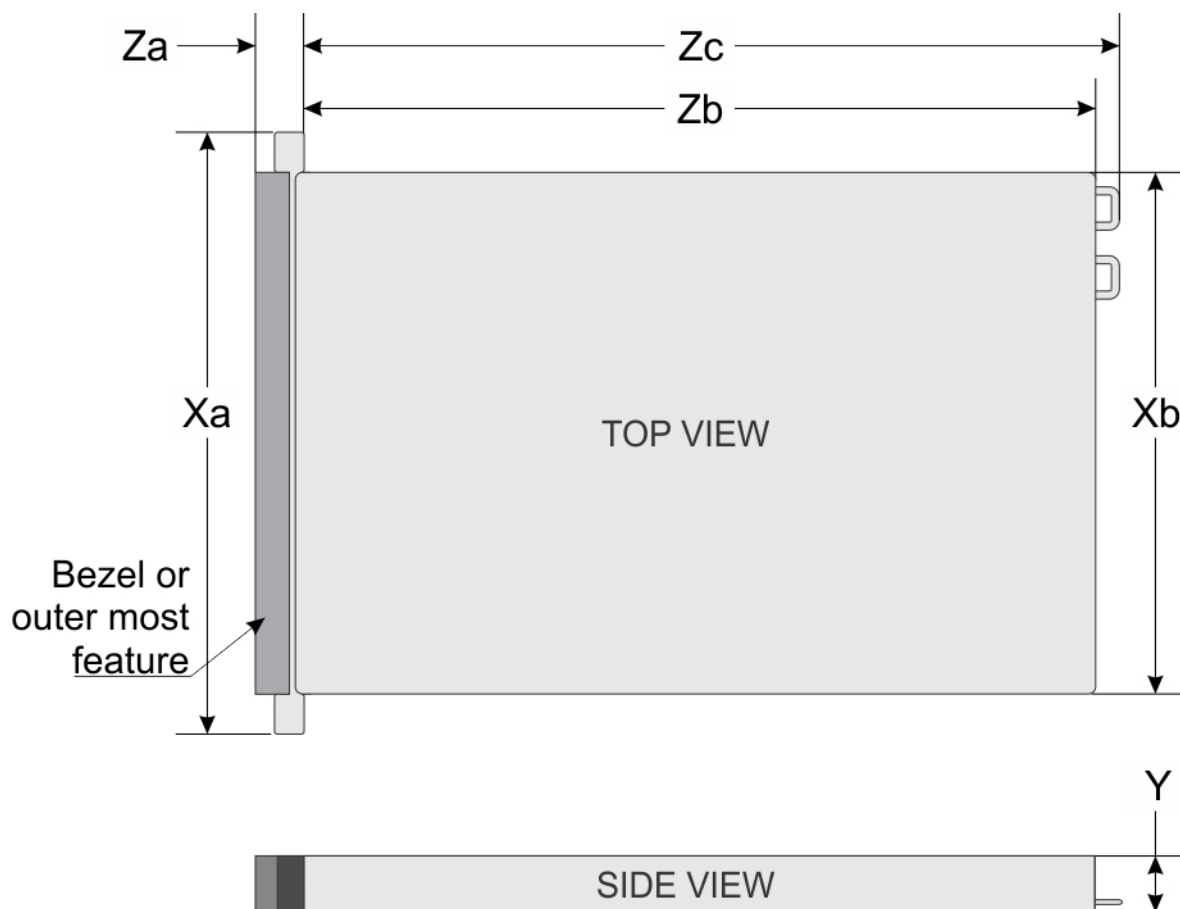

Figure 10. Chassis dimensions of Dell SD630-S system

**Table 11. Dimensions of the Dell Dell SD630-S system**

System	Xa	Xb	Y	Za (with bezel)	Za (without bezel)	Zb	Zc
Eight x 2.5-inch hard drive systems	482.4 mm	434.0 mm	42.8 mm	35.0 mm	20.4 mm	682.7 mm	701.3 mm

## Chassis weight

**Table 12. Chassis weight**

System	Maximum weight
Eight x 2.5-inch hard drive systems	16.9 kg (37. 26 lb)

## Processor specifications

The Dell SD630-S system supports up to two Intel Xeon E5-2600 v3 and v4 product family processors.

## PSU specifications

The Dell SD630-S system supports up to two AC or DC redundant power supply units (PSUs).

**Table 13. PSU specifications**

PSU	Class	Heat dissipation (maximum)	Frequency	Voltage
495 W AC	Platinum	1908 BTU/hr	50/60 Hz	100–240 V AC, autoranging
750 W AC	Platinum	2891 BTU/hr	50/60 Hz	100–240 V AC, autoranging
750 W AC	Titanium	2843 BTU/hr	50/60 Hz	200–240 V AC, autoranging
1100 W AC	Platinum	4100 BTU/hr	50/60 Hz	100–240 V AC, autoranging
1100 W DC	—	4416 BTU/hr	—	–(48–60) V DC
750 W DC (for China only)	Platinum	2902 BTU/hr	50/60 Hz	100–240 V AC and 240 V DC

**NOTE:** Heat dissipation is calculated by using the PSU wattage rating.

**NOTE:** This system is also designed to connect to the IT power systems with a phase to phase voltage not exceeding 230 V.

## System battery specifications

The Dell SD630-S system supports CR 2032 3.0-V lithium coin cell system battery.

## Expansion bus specifications

The Dell SD630-S system supports PCI express (PCIe) generation 3 expansion cards, which must be installed on the system board by using expansion card risers. This system supports three types of expansion card risers. The following table provides detailed information about the expansion card riser specifications:

**Table 14. Expansion card riser specifications**

Expansion card riser	PCIe slots on the riser	Height	Length	Link
Riser 1	Slot 1	Low Profile	Half Length	x16
	Slot 2	Low Profile	Half Length	x8
Riser 2	Slot 1	Low Profile	Half Length	x8
	Slot 1	Low Profile	Half Length	x16
Riser 3	Slot 2	Full height	Three-fourth Length	x16
	Slot 3	Low Profile	Half Length	x16

**NOTE:** When using slot 1 on the riser, ensure that both the processors are installed on the system.

**NOTE:** Only a three-fourth length card is supported for the PCIe expansion card slot (slot 2) on riser 3 when no mini-PERC card is installed. Supported length with mini-PERC card installed is half length.

## Memory specifications

The Dell SD630-S system supports DDR4 registered DIMMs (RDIMMs) at 1866 MT/s, 2133 MT/s, or 2400 MT/s registered Error Correcting Code (ECC) DIMMs and supports Advanced ECC or memory-optimized operation.

**Table 15. Memory specifications**

Memory module sockets	Memory capacity	Minimum RAM	Maximum RAM
Twenty-four 288-pins	<ul style="list-style-type: none"> <li>8 GB or 32 GB single-, dual-, or quad-ranked (RDIMMs)</li> <li>16 GB single- or dual-ranked, or 32 GB dual-ranked (RDIMMs)</li> </ul>	<ul style="list-style-type: none"> <li>8 GB with single processor</li> <li>16 GB with single processor</li> <li>32 GB with dual processors</li> </ul>	RDIMM: up to 786 GB with dual processors

## Drive specifications

### Hard drives

The Dell SD630-S system supports:

- Up to eight 2.5-inch, internal, hot swappable SAS, SATA, or Nearline SAS hard drives

### Optical drive

The Dell SD630-S system supports one optional SATA DVD-ROM drive or DVD+/-RW drive.

# Ports and connectors specifications

## USB ports

The Dell SD630-S system supports:

- USB 2.0-compliant ports on the front panel
- USB 3.0-complaint ports on the back panel
- Internal USB 3.0-compliant port

**Table 16. USB specifications**

System	Front panel	Back panel	Internal
Dell SD630-S	<ul style="list-style-type: none"><li>• Two 4-pin, USB 2.0-compliant ports</li><li>• vFlash memory card slot</li></ul>	Two 9-pin, USB 3.0-compliant ports	One 9-pin, USB 3.0-compliant

## NIC ports

The Dell SD630-S system supports four Network Interface Controller (NIC) ports on the back panel, which is available in one of the following three NIC configurations:

- Four 10/100/1000 Mbps
- Two 10/100/1000 Mbps and two 100 Mbps/1 Gbps/10 Gbps
- Four 10 Gbps

## Serial connector

The serial connector connects a serial device to the system. The Dell SD630-S system supports one serial connector on the back panel, which is a 9-pin connector, Data Terminal Equipment (DTE), 16550-compliant.

## VGA ports

The Video Graphic Array (VGA) port enables you to connect the system to a VGA display. The Dell SD630-S system supports two 15-pin VGA ports on the front and back panels.

# Video specifications

The Dell SD630-S system supports Integrated VGA controller with 16 MB capacity.

**Table 17. Resolution information for video modes**

Resolution	Refresh rate (Hz)	Color depth (bit)
640 X 480	60, 70	8, 16, 32
800 X 600	60, 75, 85	8, 16, 32
1024 X 768	60, 75, 85	8, 16, 32
1152 X 864	60, 75, 85	8, 16, 32
1280 X 1024	60, 75	8, 16, 32
1440 X 900	60	8, 16, 32

# Environmental specifications

**i** **NOTE:** For additional information about environmental measurements for specific system configurations, see [Dell.com/environmental\\_datasheets](https://www.dell.com/environmental_datasheets).

**Table 18. Temperature specifications**

Temperature	Specifications
Storage	-40°C to 65°C (-40°F to 149°F)
Continuous operation (for altitude less than 950 m or 3117 ft)	10°C to 35°C (50°F to 95°F) with no direct sunlight on the equipment. <b>i</b> <b>NOTE:</b> Maximum of 145 W 22 core processor is supported in systems with eight 2.5-inches drives, two PCI slot chassis, and 75 W single wide active GPU.
Maximum temperature gradient (operating and storage)	20°C/h (36°F/h)

**Table 19. Relative humidity specifications**

Relative humidity	Specifications
Storage	5% to 95% RH with 33°C (91°F) maximum dew point. Atmosphere must be non-condensing at all times.
Operating	10% to 80% relative humidity with 29°C (84.2°F) maximum dew point.

**Table 20. Maximum vibration specifications**

Maximum vibration	Specifications
Operating	0.26 G <sub>rms</sub> at 5 Hz to 350 Hz (all operation orientations).
Storage	1.88 G <sub>rms</sub> at 10 Hz to 500 Hz for 15 min (all six sides tested).

**Table 21. Maximum shock specifications**

Maximum shock	Specifications
Operating	Six consecutively executed shock pulses in the positive and negative x, y, and z axes of 40 G for up to 2.3 ms.
Storage	Six consecutively executed shock pulses in the positive and negative x, y, and z axes (one pulse on each side of the system) of 71 G for up to 2 ms.

**Table 22. Maximum altitude specifications**

Maximum altitude	Specifications
Operating	30482000 m (10,0006560 ft)
Storage	12,000 m (39,370 ft)

**Table 23. Operating temperature de-rating specifications**

Operating temperature de-rating	Specifications
Up to 35°C (95°F)	Maximum temperature is reduced by 1°C/300 m (1°F/547 ft) above 950 m (3,117 ft).
35°C to 40°C (95°F to 104°F)	Maximum temperature is reduced by 1°C/175 m (1°F/319 ft) above 950 m (3,117 ft).
40°C to 45°C (104°F to 113°F)	Maximum temperature is reduced by 1°C/125 m (1°F/228 ft) above 950 m (3,117 ft).

**Related references**

Expanded operating temperature on page 26

## Particulate and gaseous contamination specifications

The following table defines the limitations that help avoid any equipment damage or failure from particulates and gaseous contamination. If the level of particulates or gaseous pollution exceed the specified limitations and result in equipment damage or failure, you may need to rectify the environmental conditions. Re-mediation of environmental conditions is the responsibility of the customer.

**Table 24. Particulate contamination specifications**

Particulate contamination	Specifications
Air filtration	<p>Data center air filtration as defined by ISO Class 8 per ISO 14644-1 with a 95% upper confidence limit.</p> <p><b>NOTE:</b> This condition applies only to data center environments. Air filtration requirements do not apply to IT equipment designed to be used outside a data center, in environments such as an office or factory floor.</p> <p><b>NOTE:</b> Air entering the data center must have MERV11 or MERV13 filtration.</p>
Conductive dust	<p>Air must be free of conductive dust, zinc whiskers, or other conductive particles.</p> <p><b>NOTE:</b> This condition applies to data center and non-data center environments.</p>
Corrosive dust	<ul style="list-style-type: none"> <li>Air must be free of corrosive dust.</li> <li>Residual dust present in the air must have a deliquescent point less than 60% relative humidity.</li> </ul> <p><b>NOTE:</b> This condition applies to data center and non-data center environments.</p>

**Table 25. Gaseous contamination specifications**

Gaseous contamination	Specifications
Copper coupon corrosion rate	<300 Å/month per Class G1 as defined by ANSI/ISA71.04-1985.
Silver coupon corrosion rate	<200 Å/month as defined by AHSRAE TC9.9.

**NOTE:** Maximum corrosive contaminant levels measured at ≤50% relative humidity.

## Standard operating temperature

**Table 26. Standard operating temperature specifications**

Standard operating temperature	Specifications
Temperature ranges (for altitude less than 950 metres or 3117 feet)	<p>10°C to 35°C (50°F to 95°F) with no direct sunlight on the equipment.</p> <p><b>NOTE:</b> Maximum of 145 W 22-core processor is supported in systems with eight 2.5-inch drives 2-PCI slot chassis, and 75 W single wide active GPU.</p>
Standard operating temperature restrictions	<ul style="list-style-type: none"> <li>Ambient temperature is restricted to 30°C for systems with eight 2.5-inches drives.</li> </ul>

## Expanded operating temperature

Table 27. Expanded operating temperature specifications

Expanded operating temperature	Specifications
Continuous operation	<p>5°C to 40°C at 5% to 85% RH with 29°C dew point.</p> <p><b>NOTE:</b> Outside the standard operating temperature (10°C to 35°C), the system can operate continuously in temperatures as low as 5°C and as high as 40°C.</p> <p>For temperatures between 35°C and 40°C, de-rate maximum allowable temperature by 1°C per 175 m above 950 m (1°F per 319 ft).</p>
≤ 1% of annual operating hours	<p>–5°C to 45°C at 5% to 90% RH with 29°C dew point.</p> <p><b>NOTE:</b> Outside the standard operating temperature (10°C to 35°C), the system can operate down to –5°C or up to 45°C for a maximum of 1% of its annual operating hours.</p> <p>For temperatures between 40°C and 45°C, de-rate maximum allowable temperature by 1°C per 125 m above 950 m (1°F per 228 ft).</p>

**NOTE:** When operating in the expanded temperature range, system performance may be impacted.

**NOTE:** When operating in the expanded temperature range, ambient temperature warnings may be reported on the LCD panel and in the System Event Log.

## Expanded operating temperature restrictions

- Do not perform a cold startup below 5°C.
- The operating temperature specified is for a maximum altitude of 3050 m (10,000 ft).
- 145 W and Workstation CPU (160 W) processors are not supported.
- Two power supply units (PSUs) are needed and one PSU failure is not supported.
- Non-Dell qualified peripheral cards and/or peripheral cards greater than 25 W are not supported.
- PCIe SSD and 1.8-inch SSDs are not supported.
- GPU is not supported.

# Initial system setup and configuration

## Topics:

- [Setting up your system](#)
- [iDRAC configuration](#)
- [Options to install the operating system](#)
- [Manage your system](#)

## Setting up your system

Complete the following steps to set up your system:

### Steps

1. Unpack the system.
2. Install the system into the rack. For more information about installing the system into the rack, see your system *Rack Installation Placemat* at [Dell.com/sdscalityseriesmanuals](https://www.dell.com/sdscalityseriesmanuals).
3. Connect the peripherals to the system.
4. Connect the system to its electrical outlet.
5. Turn the system on by pressing the power button or by using iDRAC.
6. Turn on the attached peripherals.

## iDRAC configuration

The Integrated Dell Remote Access Controller (iDRAC) is designed to make system administrators more productive and improve the overall availability of Dell systems. iDRAC alerts administrators to system issues, helps them perform remote system management, and reduces the need for physical access to the system.

## Options to set up iDRAC IP address

You must configure the initial network settings based on your network infrastructure to enable the communication to and from iDRAC. You can set up the IP address by using one of the following interfaces:

Interfaces	Document/Section
<b>iDRAC Settings utility</b>	See <i>iDRAC User's Guide</i> available at <a href="https://www.dell.com/idracmanuals">https://www.dell.com/idracmanuals</a>
<b>Dell Deployment Toolkit</b>	See <i>OpenManage Deployment Toolkit User's Guide</i> available at <a href="https://www.dell.com/openmanagemanuals">https://www.dell.com/openmanagemanuals</a>
<b>Dell Lifecycle Controller</b>	See <i>Lifecycle Controller User's Guide</i> available at <a href="https://www.dell.com/idracmanuals">https://www.dell.com/idracmanuals</a>
<b>Chassis or Server LCD panel</b>	See the LCD panel section

You must use the default iDRAC IP address 192.168.0.120 to configure the initial network settings, including setting up DHCP or a static IP for iDRAC.

**NOTE:** To access iDRAC, ensure that you install the iDRAC port card or connect the network cable to the Ethernet connector 1 on the system board.

 **NOTE:** Ensure that you change the default user name and password after setting up the iDRAC IP address.

### Related references

[LCD panel](#) on page 9

## Log in to iDRAC

You can log in to iDRAC as:

- iDRAC user
- Microsoft Active Directory user
- Lightweight Directory Access Protocol (LDAP) user

The default user name and password are `root` and `calvin`. You can also log in by using Single Sign-On or Smart Card.

 **NOTE:** You must have iDRAC credentials to log in to iDRAC.

For more information about logging in to iDRAC and iDRAC licenses, see the latest Integrated Dell Remote Access Controller User's Guide at [Dell.com/idracmanuals](https://www.dell.com/idracmanuals).

## Options to install the operating system

If the system is shipped without an operating system, install the supported operating system by using one of the following resources:

**Table 28. Resources to install the operating system**

Resources	Location
Dell Systems Management Tools and Documentation media	<a href="https://www.dell.com/operatingsystemmanuals">https://www.dell.com/operatingsystemmanuals</a>
Dell Lifecycle Controller	<a href="https://www.dell.com/idracmanuals">https://www.dell.com/idracmanuals</a>
Dell OpenManage Deployment Toolkit	<a href="https://www.dell.com/openmanagemanuals">https://www.dell.com/openmanagemanuals</a>
Dell certified VMware ESXi	<a href="https://www.dell.com/virtualizationsolutions">https://www.dell.com/virtualizationsolutions</a>
Supported operating systems on Dell PowerEdge systems	<a href="http://www.dell.com/ossupport">www.dell.com/ossupport</a>
Installation and How-to videos for supported operating systems on Dell PowerEdge systems	<a href="https://www.youtube.com/playlist?list=PLe5xhhyFjDPfTCaDRFfIB_VsoLpL8x84G">https://www.youtube.com/playlist?list=PLe5xhhyFjDPfTCaDRFfIB_VsoLpL8x84G</a>

## Methods to download firmware and drivers

You can download the firmware and drivers by using the following methods:

**Table 29. Firmware and drivers**

Methods	Location
From the Dell Support site	<a href="http://Dell.com/support/home">Dell.com/support/home</a>
Using Dell Remote Access Controller Lifecycle Controller (iDRAC with LC)	<a href="http://Dell.com/idracmanuals">Dell.com/idracmanuals</a>
Using Dell Repository Manager (DRM)	<a href="http://Dell.com/openmanagemanuals">Dell.com/openmanagemanuals</a>
Using Dell OpenManage Essentials (OME)	<a href="http://Dell.com/openmanagemanuals">Dell.com/openmanagemanuals</a>
Using Dell Server Update Utility (SUU)	<a href="http://Dell.com/openmanagemanuals">Dell.com/openmanagemanuals</a>
Using Dell OpenManage Deployment Toolkit (DTK)	<a href="http://Dell.com/openmanagemanuals">Dell.com/openmanagemanuals</a>

# Manage your system

This section provides the information about server management software.

<b>Server Management Software</b>	<b>Description</b>
<b>OpenManage</b>	<p>The Dell OpenManage Server Administrator provides a comprehensive one-to-one systems management solution for both local and remote servers and their storage controllers and Direct Attached Storage (DAS).</p> <p>For information about OpenManage documents, see <a href="https://www.dell.com/openmanagemanuals">Dell.com/openmanagemanuals</a>.</p>
<b>OpenManage Essentials</b>	<p>Dell OpenManage Essentials is the newest one-to-many management console for managing Dell PowerEdge servers and direct-attached storage as it provides a simple and easy interface for system administrators to maximize the uptime and health of Dell systems.</p> <p>For information about OpenManage documents, see <a href="https://www.dell.com/openmanagemanuals">Dell.com/openmanagemanuals</a>.</p>
<b>Remote Access Controller with Dell Lifecycle Controller (iDRAC with LC)</b>	<p>iDRAC with Dell Lifecycle Controller allows administrators to deploy, update, monitor, and manage Dell servers from any location without the use of agents in a one-to-one or one-to-many method. This out-of-band management allows the updates to be sent from Dell or appropriate third-party consoles directly to iDRAC with Dell Lifecycle Controller on a Dell PowerEdge server, regardless of the operating system that may or may not be running.</p> <p>For information about Remote Enterprise Systems Management documents, see <a href="https://www.dell.com/idracmanuals">Dell.com/idracmanuals</a>.</p>
<b>Partner Programs Enterprise Systems Management</b>	<p>For information about OpenManage Connections Enterprise Systems Management documents, see <a href="https://www.dell.com/omconnectionsenterprisesystemsmanagement">Dell.com/omconnectionsenterprisesystemsmanagement</a>.</p>
<b>OpenManage Connections Client Systems Management</b>	<p>For information about OpenManage Connections Client Systems Management documents, see <a href="https://www.dell.com/dellclientcommandsuitemanuals">Dell.com/dellclientcommandsuitemanuals</a>.</p>

# Pre-operating system management applications

You can manage basic settings and features of a system without booting to the operating system by using the system firmware.

## Topics:

- [Options to manage the pre-operating system applications](#)
- [System Setup](#)
- [Dell Lifecycle Controller](#)
- [Boot Manager](#)
- [PXE boot](#)

## Options to manage the pre-operating system applications

Your system has the following options to manage the pre-operating system applications:

- System Setup
- Boot Manager
- Dell Lifecycle Controller
- Preboot Execution Environment (PXE)

### Related concepts

[System Setup](#) on page 30

[Boot Manager](#) on page 56

[Dell Lifecycle Controller](#) on page 56

[PXE boot](#) on page 58

## System Setup

By using the **System Setup** screen, you can configure the BIOS settings, iDRAC settings, and device settings of your system.

 **NOTE:** Help text for the selected field is displayed in the graphical browser by default. To view the help text in the text browser, press F1.

You can access system setup by using two methods:

- Standard graphical browser—The browser is enabled by default.
- Text browser—The browser is enabled by using Console Redirection.

### Related references

[System Setup details](#) on page 31

### Related tasks

[Viewing System Setup](#) on page 31

# Viewing System Setup

To view the **System Setup** screen, perform the following steps:

## Steps

1. Turn on, or restart your system.
2. Press F2 immediately after you see the following message:

```
F2 = System Setup
```

**NOTE:** If your operating system begins to load before you press F2, wait for the system to finish booting, and then restart your system and try again.

## Related concepts

[System Setup](#) on page 30

## Related references

[System Setup details](#) on page 31

# System Setup details

The **System Setup Main Menu** screen details are explained as follows:

Option	Description
<b>System BIOS</b>	Enables you to configure BIOS settings.
<b>iDRAC Settings</b>	Enables you to configure iDRAC settings.  The iDRAC settings utility is an interface to set up and configure the iDRAC parameters by using UEFI (Unified Extensible Firmware Interface). You can enable or disable various iDRAC parameters by using the iDRAC settings utility. For more information about this utility, see <i>Integrated Dell Remote Access Controller User's Guide</i> at <a href="http://Dell.com/idracmanuals">Dell.com/idracmanuals</a> .
<b>Device Settings</b>	Enables you to configure device settings.

## Related concepts

[System Setup](#) on page 30

## Related references

[iDRAC Settings utility](#) on page 55

[Device Settings](#) on page 56

## Related tasks

[Viewing System Setup](#) on page 31

# System BIOS

You can use the **System BIOS** screen to edit specific functions such as boot order, system password, setup password, set the RAID mode, and enable or disable USB ports.

## Related references

[System BIOS Settings details](#) on page 32

[Boot Settings](#) on page 33

- [Network Settings](#) on page 35
- [System Information](#) on page 41
- [Memory Settings](#) on page 42
- [Processor Settings](#) on page 44
- [SATA Settings](#) on page 46
- [Integrated Devices](#) on page 49
- [Serial Communication](#) on page 50
- [System Profile Settings](#) on page 52
- [Miscellaneous Settings](#) on page 54
- [iDRAC Settings utility](#) on page 55
- [Device Settings](#) on page 56
- [System Security](#) on page 37

**Related tasks**

- [Viewing System BIOS](#) on page 32

## Viewing System BIOS

To view the **System BIOS** screen, perform the following steps:

**Steps**

1. Turn on, or restart your system.
2. Press F2 immediately after you see the following message:

```
F2 = System Setup
```

 **NOTE:** If your operating system begins to load before you press F2, wait for the system to finish booting, and then restart your system and try again.

3. On the **System Setup Main Menu** screen, click **System BIOS**.

**Related references**

- [System BIOS](#) on page 31
- [System BIOS Settings details](#) on page 32

## System BIOS Settings details

**About this task**

The **System BIOS Settings** screen details are explained as follows:

Option	Description
<b>System Information</b>	Specifies information about the system such as the system model name, BIOS version, and Service Tag.
<b>Memory Settings</b>	Specifies information and options related to the installed memory.
<b>Processor Settings</b>	Specifies information and options related to the processor such as speed and cache size.
<b>SATA Settings</b>	Specifies options to enable or disable the integrated SATA controller and ports.
<b>Boot Settings</b>	Specifies options to specify the boot mode (BIOS or UEFI). Enables you to modify UEFI and BIOS boot settings.
<b>Network Settings</b>	Specifies options to change the network settings.
<b>Integrated Devices</b>	Specifies options to manage integrated device controllers and ports and specify related features and options.

Option	Description
<b>Serial Communication</b>	Specifies options to manage the serial ports and specify related features and options.
<b>System Profile Settings</b>	Specifies options to change the processor power management settings, memory frequency, and so on.
<b>System Security</b>	Specifies options to configure the system security settings, such as system password, setup password, Trusted Platform Module (TPM) security. It also manages the power and NMI buttons on the system.
<b>Miscellaneous Settings</b>	Specifies options to change the system date, time, and so on.

#### Related references

[System BIOS](#) on page 31

#### Related tasks

[Viewing System BIOS](#) on page 32

## Boot Settings

You can use the **Boot Settings** screen to set the boot mode to either **BIOS** or **UEFI**. It also enables you to specify the boot order.

#### Related references

[System BIOS](#) on page 31

[Choosing the system boot mode](#) on page 34

#### Related tasks

[Boot Settings details](#) on page 34

[Viewing Boot Settings](#) on page 33

[Changing the boot order](#) on page 35

## Viewing Boot Settings

To view the **Boot Settings** screen, perform the following steps:

#### Steps

1. Turn on, or restart your system.
2. Press F2 immediately after you see the following message:

```
F2 = System Setup
```

**NOTE:** If your operating system begins to load before you press F2, wait for the system to finish booting, and then restart your system and try again.

3. On the **System Setup Main Menu** screen, click **System BIOS**.
4. On the **System BIOS** screen, click **Boot Settings**.

#### Related references

[Boot Settings](#) on page 33

[Choosing the system boot mode](#) on page 34

## Related tasks



[Boot Settings details](#) on page 34

[Changing the boot order](#) on page 35

## Boot Settings details

### About this task

The **Boot Settings** screen details are explained as follows:

Option	Description
<b>Boot Mode</b>	<p>Enables you to set the boot mode of the system.</p> <p> <b>CAUTION: Switching the boot mode may prevent the system from booting if the operating system is not installed in the same boot mode.</b></p> <p>If the operating system supports UEFI, you can set this option to <b>UEFI</b>. Setting this field to <b>BIOS</b> allows compatibility with non-UEFI operating systems. This option is set to <b>BIOS</b> by default.</p> <p> <b>NOTE:</b> Setting this field to <b>UEFI</b> disables the <b>BIOS Boot Settings</b> menu. Setting this field to <b>BIOS</b> disables the <b>UEFI Boot Settings</b> menu.</p>
<b>Boot Sequence Retry</b>	<p>Enables or disables the Boot Sequence Retry feature. If this option is set to <b>Enabled</b> and the system fails to boot, the system reattempts the boot sequence after 30 seconds. This option is set to <b>Enabled</b> by default.</p>
<b>Hard-Disk Failover</b>	<p>Specifies the hard drive that is booted in the event of a hard drive failure. The devices are selected in the <b>Hard-Disk Drive Sequence</b> on the <b>Boot Option Setting</b> menu. When this option is set to <b>Disabled</b>, only the first hard drive in the list is attempted to boot. When this option is set to <b>Enabled</b>, all hard drives are attempted to boot in the order selected in the <b>Hard-Disk Drive Sequence</b>. This option is not enabled for UEFI Boot Mode.</p>
<b>Boot Option Settings</b>	<p>Configures the boot sequence and the boot devices.</p>

### Related references

[Boot Settings](#) on page 33

[Choosing the system boot mode](#) on page 34

### Related tasks

[Viewing Boot Settings](#) on page 33

[Changing the boot order](#) on page 35

## Choosing the system boot mode

System Setup enables you to specify one of the following boot modes for installing your operating system:

- BIOS boot mode (the default) is the standard BIOS-level boot interface.
- Unified Extensible Firmware Interface (UEFI) boot mode is an enhanced 64-bit boot interface. If you have configured your system to boot to UEFI mode, it replaces the system BIOS.

1. From the **System Setup Main Menu**, click **Boot Settings**, and select **Boot Mode**.
2. Select the boot mode you want the system to boot into.

 **CAUTION: Switching the boot mode may prevent the system from booting if the operating system is not installed in the same boot mode.**

3. After the system boots in the specified boot mode, proceed to install your operating system from that mode.

 **NOTE:** Operating systems must be UEFI-compatible to be installed from the UEFI boot mode. DOS and 32-bit operating systems do not support UEFI and can only be installed from the BIOS boot mode.

 **NOTE:** For the latest information about supported operating systems, go to [Dell.com/ossupport](https://www.dell.com/ossupport).

## Related references

[Boot Settings](#) on page 33

## Related tasks

[Boot Settings details](#) on page 34

[Viewing Boot Settings](#) on page 33

## Changing the boot order

You may have to change the boot order if you want to boot from a USB key or an optical drive. The following instructions may vary if you have selected **BIOS** for **Boot Mode**.

### Steps

1. On the **System Setup Main Menu** screen, click **System BIOS > Boot Settings**.
2. Click **Boot Option Settings > Boot Sequence**.
3. Use the arrow keys to select a boot device, and use the plus (+) and minus (-) sign keys to move the device down or up in the order.
4. Click **Exit**, and then click **Yes** to save the settings on exit.

## Related references

[Boot Settings](#) on page 33

## Related tasks

[Boot Settings details](#) on page 34

[Viewing Boot Settings](#) on page 33

## Network Settings

You can use the **Network Settings** screen to modify PXE device settings. The network settings option is available only in the UEFI mode.

 **NOTE:** The BIOS does not control network settings in the BIOS mode. For the BIOS boot mode, the optional Boot ROM of the network controllers handles the network settings.

## Related concepts

[UEFI iSCSI Settings](#) on page 36

## Related references

[Network Settings screen details](#) on page 36

[UEFI iSCSI Settings details](#) on page 37

[System BIOS](#) on page 31

## Related tasks

[Viewing Network Settings](#) on page 35

[Viewing UEFI iSCSI Settings](#) on page 36

## Viewing Network Settings

To view the **Network Settings** screen, perform the following steps:

### Steps

1. Turn on, or restart your system.

2. Press F2 immediately after you see the following message:

F2 = System Setup

**NOTE:** If your operating system begins to load before you press F2, wait for the system to finish booting, and then restart your system and try again.

3. On the **System Setup Main Menu** screen, click **System BIOS**.

4. On the **System BIOS** screen, click **Network Settings**.

#### Related references

[Network Settings](#) on page 35

[Network Settings screen details](#) on page 36

## Network Settings screen details

The **Network Settings** screen details are explained as follows:

#### About this task

Option	Description
<b>PXE Device n (n = 1 to 4)</b>	Enables or disables the device. When enabled, a UEFI boot option is created for the device.
<b>PXE Device n Settings (n = 1 to 4)</b>	Enables you to control the configuration of the PXE device.

#### Related references

[Network Settings](#) on page 35

#### Related tasks

[Viewing Network Settings](#) on page 35

## UEFI iSCSI Settings

You can use the iSCSI Settings screen to modify iSCSI device settings. The iSCSI Settings option is available only in the UEFI boot mode. BIOS does not control network settings in the BIOS boot mode. For the BIOS boot mode, the option ROM of the network controller handles the network settings.

#### Related references

[UEFI iSCSI Settings details](#) on page 37

#### Related tasks

[Viewing UEFI iSCSI Settings](#) on page 36

### Viewing UEFI iSCSI Settings

To view the **UEFI iSCSI Settings** screen, perform the following steps:

#### Steps

1. Turn on, or restart your system.
2. Press F2 immediately after you see the following message:

F2 = System Setup

**NOTE:** If your operating system begins to load before you press F2, wait for the system to finish booting, and then restart your system and try again.

3. On the **System Setup Main Menu** screen, click **System BIOS**.
4. On the **System BIOS** screen, click **Network Settings**.
5. On the **Network Settings** screen, click **UEFI iSCSI Settings**.

#### Related references

[UEFI iSCSI Settings](#) on page 36

#### UEFI iSCSI Settings details

The **UEFI iSCSI Settings** screen details are explained as follows:

Option	Description
<b>iSCSI Initiator Name</b>	Specifies the name of the iSCSI initiator (iqn format).
<b>iSCSI Device n (n = 1 to 4)</b>	Enables or disables the iSCSI device. When disabled, a UEFI boot option is created for the iSCSI device automatically.

## System Security

You can use the **System Security** screen to perform specific functions such as setting the system password, setup password and disabling the power button.

#### Related references

[Operating with a setup password enabled](#) on page 41

[System BIOS](#) on page 31

#### Related tasks

[System Security Settings details](#) on page 38

[Viewing System Security](#) on page 37

[Creating a system and setup password](#) on page 39

[Using your system password to secure your system](#) on page 40

[Deleting or changing system and setup password](#) on page 40

## Viewing System Security

To view the **System Security** screen, perform the following steps:

#### Steps

1. Turn on, or restart your system.
2. Press F2 immediately after you see the following message:

```
F2 = System Setup
```

**NOTE:** If your operating system begins to load before you press F2, wait for the system to finish booting, and then restart your system and try again.

3. On the **System Setup Main Menu** screen, click **System BIOS**.
4. On the **System BIOS** screen, click **System Security**.

#### Related references

[System Security](#) on page 37



## Related tasks

[System Security Settings details](#) on page 38

## System Security Settings details

### About this task

The **System Security Settings** screen details are explained as follows:

Option	Description
<b>Intel AES-NI</b>	Improves the speed of applications by performing encryption and decryption by using the Advanced Encryption Standard Instruction Set (AES-NI). This option is set to <b>Enabled</b> by default.
<b>System Password</b>	Sets the system password. This option is set to <b>Enabled</b> by default and is read-only if the password jumper is not installed in the system.
<b>Setup Password</b>	Sets the setup password. This option is read-only if the password jumper is not installed in the system.
<b>Password Status</b>	Locks the system password. This option is set to <b>Unlocked</b> by default.
<b>TPM Security</b>	 <b>NOTE:</b> The TPM menu is available only when the TPM module is installed.  Enables you to control the reporting mode of the TPM. The <b>TPM Security</b> option is set to <b>Off</b> by default. You can only modify the TPM Status, TPM Activation, and Intel TXT fields if the <b>TPM Status</b> field is set to either <b>On with Pre-boot Measurements</b> or <b>On without Pre-boot Measurements</b> .
<b>TPM Information</b>	Changes the operational state of the TPM. This option is set to <b>No Change</b> by default.
<b>TPM Status</b>	Specifies the TPM status.
<b>TPM Command</b>	 <b>CAUTION:</b> Clearing the TPM results in the loss of all keys in the TPM. The loss of TPM keys may affect booting to the operating system.  Clears all the contents of the TPM. The <b>TPM Clear</b> option is set to <b>No</b> by default.
<b>Intel TXT</b>	Enables or disables the Intel Trusted Execution Technology (TXT) option. To enable the <b>Intel TXT</b> option, virtualization technology and TPM Security must be enabled with Pre-boot measurements. This option is set to <b>Off</b> by default.
<b>Power Button</b>	Enables or disables the power button on the front of the system. This option is set to <b>Enabled</b> by default.
<b>NMI Button</b>	Enables or disables the NMI button on the front of the system. This option is set to <b>Disabled</b> by default.
<b>AC Power Recovery</b>	Sets how the system behaves after AC power is restored to the system. This option is set to <b>Last</b> by default.
<b>AC Power Recovery Delay</b>	Sets the time delay for the system to power up after AC power is restored to the system. This option is set to <b>Immediate</b> by default.
<b>User Defined Delay (60s to 240s)</b>	Sets the <b>User Defined Delay</b> option when the <b>User Defined</b> option for <b>AC Power Recovery Delay</b> is selected.
<b>UEFI Variable Access</b>	Provides varying degrees of securing UEFI variables. When set to <b>Standard</b> (the default), UEFI variables are accessible in the operating system per the UEFI specification. When set to <b>Controlled</b> , selected UEFI variables are protected in the environment and new UEFI boot entries are forced to be at the end of the current boot order.
<b>Secure Boot</b>	Enables Secure Boot, where the BIOS authenticates each pre-boot image by using the certificates in the Secure Boot Policy. Secure Boot is disabled by default.
<b>Secure Boot Policy</b>	When Secure Boot policy is set to <b>Standard</b> , the BIOS uses the system manufacturer's key and certificates to authenticate pre-boot images. When Secure Boot policy is set to <b>Custom</b> , the BIOS uses the user-defined key and certificates. Secure Boot policy is set to <b>Standard</b> by default.
<b>Secure Boot Policy Summary</b>	Specifies the list of certificates and hashes that secure boot uses to authenticate images.

## Related references

[System Security](#) on page 37

## Related tasks

[Viewing System Security](#) on page 37

# Secure Boot Custom Policy Settings

Secure Boot Custom Policy Settings is displayed only when **Secure Boot Policy** is set to **Custom**.

## Viewing Secure Boot Custom Policy Settings

To view the **Secure Boot Custom Policy Settings** screen, perform the following steps:

### Steps

1. Turn on, or restart your system.
2. Press F2 immediately after you see the following message:

```
F2 = System Setup
```

**NOTE:** If your operating system begins to load before you press F2, wait for the system to finish booting, and then restart your system and try again.

3. On the **System Setup Main Menu** screen, click **System BIOS**.
4. On the **System BIOS** screen, click **System Security**.
5. On the **System Security** screen, click **Secure Boot Custom Policy Settings**.

## Secure Boot Custom Policy Settings details

The **Secure Boot Custom Policy Settings** screen details are explained as follows:

Option	Description
<b>Platform Key</b>	Imports, exports, deletes, or restores the platform key (PK).
<b>Key Exchange Key Database</b>	Enables you to import, export, delete, or restore entries in the Key Exchange Key (KEK) Database.
<b>Authorized Signature Database</b>	Imports, exports, deletes, or restores entries in the Authorized Signature Database (db).
<b>Forbidden Signature Database</b>	Imports, exports, deletes, or restores entries in the Forbidden Signature Database (dbx).

# Creating a system and setup password

## Prerequisites

Ensure that the password jumper is enabled. The password jumper enables or disables the system password and setup password features. For more information, see the System board jumper settings section.

**NOTE:** If the password jumper setting is disabled, the existing system password and setup password are deleted and you need not provide the system password to boot the system.

### Steps

1. To enter System Setup, press F2 immediately after turning on or rebooting your system.
2. On the **System Setup Main Menu** screen, click **System BIOS > System Security**.

3. On the **System Security** screen, verify that **Password Status** is set to **Unlocked**.
4. In the **System Password** field, type your system password, and press Enter or Tab.  
Use the following guidelines to assign the system password:
  - A password can have up to 32 characters.
  - The password can contain the numbers 0 through 9.
  - Only the following special characters are allowed: space, ("), (+), (.), (-), (.), (/), (;), ([], (\), (]), (`).

A message prompts you to reenter the system password.

5. Reenter the system password, and click **OK**.
6. In the **Setup Password** field, type your setup password and press Enter or Tab.  
A message prompts you to reenter the setup password.
7. Reenter the setup password, and click **OK**.
8. Press Esc to return to the System BIOS screen. Press Esc again.  
A message prompts you to save the changes.

 **NOTE:** Password protection does not take effect until the system reboots.

### Related references

[System Security](#) on page 37

## Using your system password to secure your system

If you have assigned a setup password, the system accepts your setup password as an alternate system password.

### Steps

1. Turn on or reboot your system.
2. Type the system password and press Enter.

### Next steps

When **Password Status** is set to **Locked**, type the system password and press Enter when prompted at reboot.

 **NOTE:** If an incorrect system password is typed, the system displays a message and prompts you to reenter your password. You have three attempts to type the correct password. After the third unsuccessful attempt, the system displays an error message that the system has stopped functioning and must be turned off. Even after you turn off and restart the system, the error message is displayed until the correct password is entered.

### Related references

[System Security](#) on page 37

## Deleting or changing system and setup password

### Prerequisites

 **NOTE:** You cannot delete or change an existing system or setup password if the **Password Status** is set to **Locked**.

### Steps

1. To enter System Setup, press F2 immediately after turning on or restarting your system.
2. On the **System Setup Main Menu** screen, click **System BIOS > System Security**.
3. On the **System Security** screen, ensure that **Password Status** is set to **Unlocked**.
4. In the **System Password** field, alter or delete the existing system password, and then press Enter or Tab.
5. In the **Setup Password** field, alter or delete the existing setup password, and then press Enter or Tab.  
If you change the system and setup password, a message prompts you to reenter the new password. If you delete the system and setup password, a message prompts you to confirm the deletion.

6. Press Esc to return to the **System BIOS** screen. Press Esc again, and a message prompts you to save the changes.

#### Related references

[System Security](#) on page 37

## Operating with a setup password enabled

If **Setup Password** is set to **Enabled**, type the correct setup password before modifying the system setup options.

If you do not type the correct password in three attempts, the system displays the following message:

```
Invalid Password! Number of unsuccessful password attempts: <x> System Halted! Must power down.
```

Even after you turn off and restart the system, the error message is displayed until the correct password is typed. The following options are exceptions:

- If **System Password** is not set to **Enabled** and is not locked through the **Password Status** option, you can assign a system password. For more information, see the System Security Settings screen section.
- You cannot disable or change an existing system password.

 **NOTE:** You can use the password status option with the setup password option to protect the system password from unauthorized changes.

#### Related references

[System Security](#) on page 37

## System Information

You can use the **System Information** screen to view system properties such as Service Tag, system model name, and the BIOS version.

#### Related references

[System Information details](#) on page 42

[System BIOS](#) on page 31

#### Related tasks

[Viewing System Information](#) on page 41

## Viewing System Information

To view the **System Information** screen, perform the following steps:

#### Steps

1. Turn on, or restart your system.
2. Press F2 immediately after you see the following message:

```
F2 = System Setup
```

 **NOTE:** If your operating system begins to load before you press F2, wait for the system to finish booting, and then restart your system and try again.

3. On the **System Setup Main Menu** screen, click **System BIOS**.
4. On the **System BIOS** screen, click **System Information**.

### Related references

[System Information](#) on page 41

## System Information details

### About this task

The **System Information** screen details are explained as follows:

Option	Description
<b>System Model Name</b>	Specifies the system model name.
<b>System BIOS Version</b>	Specifies the BIOS version installed on the system.
<b>System Management Engine Version</b>	Specifies the current version of the Management Engine firmware.
<b>System Service Tag</b>	Specifies the system Service Tag.
<b>System Manufacturer</b>	Specifies the name of the system manufacturer.
<b>System Manufacturer Contact Information</b>	Specifies the contact information of the system manufacturer.
<b>System CPLD Version</b>	Specifies the current version of the system complex programmable logic device (CPLD) firmware.
<b>UEFI Compliance Version</b>	Specifies the UEFI compliance level of the system firmware.

### Related references

[System Information](#) on page 41

[System Information details](#) on page 42

### Related tasks

[Viewing System Information](#) on page 41

## Memory Settings

You can use the **Memory Settings** screen to view all the memory settings and enable or disable specific memory functions, such as system memory testing and node interleaving.

### Related references

[Memory Settings details](#) on page 43

[System BIOS](#) on page 31

### Related tasks

[Viewing Memory Settings](#) on page 43

## Viewing Memory Settings

To view the **Memory Settings** screen, perform the following steps:

### Steps

1. Turn on, or restart your system.
2. Press F2 immediately after you see the following message:

```
F2 = System Setup
```

**NOTE:** If your operating system begins to load before you press F2, wait for the system to finish booting, and then restart your system and try again.

3. On the **System Setup Main Menu** screen, click **System BIOS**.
4. On the **System BIOS** screen, click **Memory Settings**.

### Related references

[Memory Settings](#) on page 42

[Memory Settings details](#) on page 43

## Memory Settings details

### About this task

The **Memory Settings** screen details are explained as follows:

Option	Description
<b>System Memory Size</b>	Specifies the memory size in the system.
<b>System Memory Type</b>	Specifies the type of memory installed in the system.
<b>System Memory Speed</b>	Specifies the system memory speed.
<b>System Memory Voltage</b>	Specifies the system memory voltage.
<b>Video Memory</b>	Specifies the amount of video memory.
<b>System Memory Testing</b>	Specifies whether the system memory tests are run during system boot. Options are <b>Enabled</b> and <b>Disabled</b> . This option is set to <b>Disabled</b> by default.
<b>Memory Operating Mode</b>	Specifies the memory operating mode. The options available are <b>Optimizer Mode</b> , <b>Advanced ECC Mode</b> , <b>Mirror Mode</b> , <b>Spare Mode</b> , <b>Spare with Advanced ECC Mode</b> , <b>Dell Fault Resilient Mode</b> and <b>Dell NUMA Fault Resilient Mode</b> . This option is set to <b>Optimizer Mode</b> by default. <b>NOTE:</b> The <b>Memory Operating Mode</b> option can have different default and available options based on the memory configuration of your system. <b>NOTE:</b> The <b>Dell Fault Resilient Mode</b> option establishes an area of memory that is fault resilient. This mode can be used by an operating system that supports the feature to load critical applications or enables the operating system kernel to maximize system availability.
<b>Node Interleaving</b>	Specifies if Non-Uniform Memory architecture (NUMA) is supported. If this field is set to <b>Enabled</b> , memory interleaving is supported if a symmetric memory configuration is installed. If the field is set to <b>Disabled</b> , the system supports NUMA (asymmetric) memory configurations. This option is set to <b>Disabled</b> by default.
<b>Snoop Mode</b>	Specifies the Snoop Mode options. The Snoop Mode options available are <b>Home Snoop</b> , <b>Early Snoop</b> , and <b>Cluster on Die</b> . This option is set to <b>Early Snoop</b> by default. This field is available only when the <b>Node Interleaving</b> is set to <b>Disabled</b> .

### Related references

[Memory Settings](#) on page 42

### Related tasks

[Viewing Memory Settings](#) on page 43

## Processor Settings

You can use the **Processor Settings** screen to view the processor settings, and perform specific functions such as enabling virtualization technology, hardware prefetcher, and logical processor idling.

### Related references

[Processor Settings details](#) on page 44

[System BIOS](#) on page 31

### Related tasks

[Viewing Processor Settings](#) on page 44

## Viewing Processor Settings

To view the **Processor Settings** screen, perform the following steps:

### Steps

1. Turn on, or restart your system.
2. Press F2 immediately after you see the following message:

```
F2 = System Setup
```



**NOTE:** If your operating system begins to load before you press F2, wait for the system to finish booting, and then restart your system and try again.

3. On the **System Setup Main Menu** screen, click **System BIOS**.
4. On the **System BIOS** screen, click **Processor Settings**.

### Related references

[Processor Settings](#) on page 44



[Processor Settings details](#) on page 44

## Processor Settings details

### About this task

The **Processor Settings** screen details are explained as follows:

Option	Description
<b>Logical Processor</b>	Enables or disables the logical processors and displays the number of logical processors. If this option is set to <b>Enabled</b> , the BIOS displays all the logical processors. If this option is set to <b>Disabled</b> , the BIOS displays only one logical processor per core. This option is set to <b>Enabled</b> by default.
<b>QPI Speed</b>	Enables you to control QuickPath Interconnect data rate settings.
<b>Alternate RTID (Requestor Transaction ID) Setting</b>	Modifies Requestor Transaction IDs, which are QPI resources. This option is set to <b>Disabled</b> by default. <b>NOTE:</b> Enabling this option may negatively impact the overall system performance.

Option	Description
<b>Virtualization Technology</b>	Enables or disables the additional hardware capabilities provided for virtualization. This option is set to <b>Enabled</b> by default.
<b>Address Translation Service (ATS)</b>	Defines the Address Translation Cache (ATC) for devices to cache the DMA transactions. This option provides an interface between CPU and DMA Memory Management to a chipset's Address Translation and Protection Table to translate DMA addresses to host addresses. This option is set to <b>Enabled</b> by default.
<b>Adjacent Cache Line Prefetch</b>	Optimizes the system for applications that need high utilization of sequential memory access. This option is set to <b>Enabled</b> by default. You can disable this option for applications that need high utilization of random memory access.
<b>Hardware Prefetcher</b>	Enables or disables the hardware prefetcher. This option is set to <b>Enabled</b> by default.
<b>DCU Streamer Prefetcher</b>	Enables or disables the Data Cache Unit (DCU) streamer prefetcher. This option is set to <b>Enabled</b> by default.
<b>DCU IP Prefetcher</b>	Enables or disables the Data Cache Unit (DCU) IP prefetcher. This option is set to <b>Enabled</b> by default.
<b>Logical Processor Idling</b>	Enables you to improve the energy efficiency of a system. It uses the operating system core parking algorithm and parks some of the logical processors in the system which in turn allows the corresponding processor cores to transition into a lower power idle state. This option can only be enabled if the operating system supports it. It is set to <b>Disabled</b> by default.
<b>Configurable TDP</b>	Enables you to reconfigure the processor Thermal Design Power (TDP) levels during POST based on the power and thermal delivery capabilities of the system. TDP verifies the maximum heat the cooling system is needed to dissipate. This option is set to <b>Nominal</b> by default.  <b>NOTE:</b> This option is only available on certain stock keeping units (SKUs) of the processors.
<b>X2Apic Mode</b>	Enables or disables the X2Apic mode.
<b>Dell Controlled Turbo</b>	Controls the turbo engagement. Enable this option only when <b>System Profile</b> is set to <b>Performance</b> .  <b>NOTE:</b> Depending on the number of installed CPUs, there may be up to four processor listings.
<b>Number of Cores per Processor</b>	Controls the number of enabled cores in each processor. This option is set to <b>All</b> by default.
<b>Processor 64-bit Support</b>	Specifies if the processor(s) support 64-bit extensions.
<b>Processor Core Speed</b>	Specifies the maximum core frequency of the processor.
<b>Processor 1</b>	 <b>NOTE:</b> Depending on the number of CPUs, there may be up to four processors listed.

The following settings are displayed for each processor installed in the system:

Option	Description
<b>Family-Model-Stepping</b>	Specifies the family, model, and stepping of the processor as defined by Intel.
<b>Brand</b>	Specifies the brand name.
<b>Level 2 Cache</b>	Specifies the total L2 cache.
<b>Level 3 Cache</b>	Specifies the total L3 cache.
<b>Number of Cores</b>	Specifies the number of cores per processor.

## Related references

[Processor Settings](#) on page 44

## Related tasks

[Viewing Processor Settings](#) on page 44

# SATA Settings

You can use the **SATA Settings** screen to view the SATA settings of SATA devices and enable RAID on your system.

## Related references

[System BIOS](#) on page 31

## Related tasks

[SATA Settings details](#) on page 46

[Viewing SATA Settings](#) on page 46

## Viewing SATA Settings

To view the **SATA Settings** screen, perform the following steps:

### Steps

1. Turn on, or restart your system.
2. Press F2 immediately after you see the following message:

```
F2 = System Setup
```

 **NOTE:** If your operating system begins to load before you press F2, wait for the system to finish booting, and then restart your system and try again.

3. On the **System Setup Main Menu** screen, click **System BIOS**.
4. On the **System BIOS** screen, click **SATA Settings**.

## Related references

[SATA Settings](#) on page 46

## Related tasks

[SATA Settings details](#) on page 46

## SATA Settings details

### About this task

The **SATA Settings** screen details are explained as follows:

Option	Description
<b>Embedded SATA</b>	Enables the embedded SATA option to be set to <b>Off</b> , <b>ATA</b> , <b>AHCI</b> , or <b>RAID</b> modes. This option is set to <b>AHCI</b> by default.
<b>Security Freeze Lock</b>	Sends Security Freeze Lock command to the Embedded SATA drives during POST. This option is applicable only for ATA and AHCI modes.
<b>Write Cache</b>	Enables or disables the command for Embedded SATA drives during POST.
<b>Port A</b>	Sets the drive type of the selected device. For <b>Embedded SATA settings</b> in <b>ATA</b> mode, set this field to <b>Auto</b> to enable BIOS support. Set it to <b>OFF</b> to turn off BIOS support. For <b>AHCI</b> or <b>RAID</b> mode, BIOS support is always enabled.

<b>Option</b>	<b>Description</b>								
	<table border="0"> <thead> <tr> <th style="text-align: left;"><b>Option</b></th> <th style="text-align: left;"><b>Description</b></th> </tr> </thead> <tbody> <tr> <td><b>Model</b></td> <td>Specifies the drive model of the selected device.</td> </tr> <tr> <td><b>Drive Type</b></td> <td>Specifies the type of drive attached to the SATA port.</td> </tr> <tr> <td><b>Capacity</b></td> <td>Specifies the total capacity of the hard drive. This field is undefined for removable media devices such as optical drives.</td> </tr> </tbody> </table>	<b>Option</b>	<b>Description</b>	<b>Model</b>	Specifies the drive model of the selected device.	<b>Drive Type</b>	Specifies the type of drive attached to the SATA port.	<b>Capacity</b>	Specifies the total capacity of the hard drive. This field is undefined for removable media devices such as optical drives.
<b>Option</b>	<b>Description</b>								
<b>Model</b>	Specifies the drive model of the selected device.								
<b>Drive Type</b>	Specifies the type of drive attached to the SATA port.								
<b>Capacity</b>	Specifies the total capacity of the hard drive. This field is undefined for removable media devices such as optical drives.								
<b>Port B</b>	<p>Sets the drive type of the selected device. For <b>Embedded SATA settings</b> in <b>ATA</b> mode, set this field to <b>Auto</b> to enable BIOS support. Set it to <b>OFF</b> to turn off BIOS support.</p> <p>For <b>AHCI</b> or <b>RAID</b> mode, BIOS support is always enabled.</p> <table border="0"> <thead> <tr> <th style="text-align: left;"><b>Option</b></th> <th style="text-align: left;"><b>Description</b></th> </tr> </thead> <tbody> <tr> <td><b>Model</b></td> <td>Specifies the drive model of the selected device.</td> </tr> <tr> <td><b>Drive Type</b></td> <td>Specifies the type of drive attached to the SATA port.</td> </tr> <tr> <td><b>Capacity</b></td> <td>Specifies the total capacity of the hard drive. This field is undefined for removable media devices such as optical drives.</td> </tr> </tbody> </table>	<b>Option</b>	<b>Description</b>	<b>Model</b>	Specifies the drive model of the selected device.	<b>Drive Type</b>	Specifies the type of drive attached to the SATA port.	<b>Capacity</b>	Specifies the total capacity of the hard drive. This field is undefined for removable media devices such as optical drives.
<b>Option</b>	<b>Description</b>								
<b>Model</b>	Specifies the drive model of the selected device.								
<b>Drive Type</b>	Specifies the type of drive attached to the SATA port.								
<b>Capacity</b>	Specifies the total capacity of the hard drive. This field is undefined for removable media devices such as optical drives.								
<b>Port C</b>	<p>Sets the drive type of the selected device. For <b>Embedded SATA settings</b> in <b>ATA</b> mode, set this field to <b>Auto</b> to enable BIOS support. Set it to <b>OFF</b> to turn off BIOS support.</p> <p>For <b>AHCI</b> or <b>RAID</b> mode, BIOS support is always enabled.</p> <table border="0"> <thead> <tr> <th style="text-align: left;"><b>Option</b></th> <th style="text-align: left;"><b>Description</b></th> </tr> </thead> <tbody> <tr> <td><b>Model</b></td> <td>Specifies the drive model of the selected device.</td> </tr> <tr> <td><b>Drive Type</b></td> <td>Specifies the type of drive attached to the SATA port.</td> </tr> <tr> <td><b>Capacity</b></td> <td>Specifies the total capacity of the hard drive. This field is undefined for removable media devices such as optical drives.</td> </tr> </tbody> </table>	<b>Option</b>	<b>Description</b>	<b>Model</b>	Specifies the drive model of the selected device.	<b>Drive Type</b>	Specifies the type of drive attached to the SATA port.	<b>Capacity</b>	Specifies the total capacity of the hard drive. This field is undefined for removable media devices such as optical drives.
<b>Option</b>	<b>Description</b>								
<b>Model</b>	Specifies the drive model of the selected device.								
<b>Drive Type</b>	Specifies the type of drive attached to the SATA port.								
<b>Capacity</b>	Specifies the total capacity of the hard drive. This field is undefined for removable media devices such as optical drives.								
<b>Port D</b>	<p>Sets the drive type of the selected device. For <b>Embedded SATA settings</b> in <b>ATA</b> mode, set this field to <b>Auto</b> to enable BIOS support. Set it to <b>OFF</b> to turn off BIOS support.</p> <p>For <b>AHCI</b> or <b>RAID</b> mode, BIOS support is always enabled.</p> <table border="0"> <thead> <tr> <th style="text-align: left;"><b>Option</b></th> <th style="text-align: left;"><b>Description</b></th> </tr> </thead> <tbody> <tr> <td><b>Model</b></td> <td>Specifies the drive model of the selected device.</td> </tr> <tr> <td><b>Drive Type</b></td> <td>Specifies the type of drive attached to the SATA port.</td> </tr> <tr> <td><b>Capacity</b></td> <td>Specifies the total capacity of the hard drive. This field is undefined for removable media devices such as optical drives.</td> </tr> </tbody> </table>	<b>Option</b>	<b>Description</b>	<b>Model</b>	Specifies the drive model of the selected device.	<b>Drive Type</b>	Specifies the type of drive attached to the SATA port.	<b>Capacity</b>	Specifies the total capacity of the hard drive. This field is undefined for removable media devices such as optical drives.
<b>Option</b>	<b>Description</b>								
<b>Model</b>	Specifies the drive model of the selected device.								
<b>Drive Type</b>	Specifies the type of drive attached to the SATA port.								
<b>Capacity</b>	Specifies the total capacity of the hard drive. This field is undefined for removable media devices such as optical drives.								
<b>Port E</b>	<p>Sets the drive type of the selected device. For <b>Embedded SATA settings</b> in <b>ATA</b> mode, set this field to <b>Auto</b> to enable BIOS support. Set it to <b>OFF</b> to turn off BIOS support.</p> <p>For <b>AHCI</b> or <b>RAID</b> mode, BIOS support is always enabled.</p> <table border="0"> <thead> <tr> <th style="text-align: left;"><b>Option</b></th> <th style="text-align: left;"><b>Description</b></th> </tr> </thead> <tbody> <tr> <td><b>Model</b></td> <td>Specifies the drive model of the selected device.</td> </tr> <tr> <td><b>Drive Type</b></td> <td>Specifies the type of drive attached to the SATA port.</td> </tr> <tr> <td><b>Capacity</b></td> <td>Specifies the total capacity of the hard drive. This field is undefined for removable media devices such as optical drives.</td> </tr> </tbody> </table>	<b>Option</b>	<b>Description</b>	<b>Model</b>	Specifies the drive model of the selected device.	<b>Drive Type</b>	Specifies the type of drive attached to the SATA port.	<b>Capacity</b>	Specifies the total capacity of the hard drive. This field is undefined for removable media devices such as optical drives.
<b>Option</b>	<b>Description</b>								
<b>Model</b>	Specifies the drive model of the selected device.								
<b>Drive Type</b>	Specifies the type of drive attached to the SATA port.								
<b>Capacity</b>	Specifies the total capacity of the hard drive. This field is undefined for removable media devices such as optical drives.								
<b>Port F</b>	<p>Sets the drive type of the selected device. For <b>Embedded SATA settings</b> in <b>ATA</b> mode, set this field to <b>Auto</b> to enable BIOS support. Set it to <b>OFF</b> to turn off BIOS support.</p> <p>For <b>AHCI</b> or <b>RAID</b> mode, BIOS support is always enabled.</p>								

Option	Description								
	<table border="1"> <thead> <tr> <th>Option</th> <th>Description</th> </tr> </thead> <tbody> <tr> <td><b>Model</b></td> <td>Specifies the drive model of the selected device.</td> </tr> <tr> <td><b>Drive Type</b></td> <td>Specifies the type of drive attached to the SATA port.</td> </tr> <tr> <td><b>Capacity</b></td> <td>Specifies the total capacity of the hard drive. This field is undefined for removable media devices such as optical drives.</td> </tr> </tbody> </table>	Option	Description	<b>Model</b>	Specifies the drive model of the selected device.	<b>Drive Type</b>	Specifies the type of drive attached to the SATA port.	<b>Capacity</b>	Specifies the total capacity of the hard drive. This field is undefined for removable media devices such as optical drives.
Option	Description								
<b>Model</b>	Specifies the drive model of the selected device.								
<b>Drive Type</b>	Specifies the type of drive attached to the SATA port.								
<b>Capacity</b>	Specifies the total capacity of the hard drive. This field is undefined for removable media devices such as optical drives.								
<b>Port G</b>	<p>Sets the drive type of the selected device. For <b>Embedded SATA settings</b> in <b>ATA</b> mode, set this field to <b>Auto</b> to enable BIOS support. Set it to <b>OFF</b> to turn off BIOS support.</p> <p>For <b>AHCI</b> or <b>RAID</b> mode, BIOS support is always enabled.</p> <table border="1"> <thead> <tr> <th>Option</th> <th>Description</th> </tr> </thead> <tbody> <tr> <td><b>Model</b></td> <td>Specifies the drive model of the selected device.</td> </tr> <tr> <td><b>Drive Type</b></td> <td>Specifies the type of drive attached to the SATA port.</td> </tr> <tr> <td><b>Capacity</b></td> <td>Specifies the total capacity of the hard drive. This field is undefined for removable media devices such as optical drives.</td> </tr> </tbody> </table>	Option	Description	<b>Model</b>	Specifies the drive model of the selected device.	<b>Drive Type</b>	Specifies the type of drive attached to the SATA port.	<b>Capacity</b>	Specifies the total capacity of the hard drive. This field is undefined for removable media devices such as optical drives.
Option	Description								
<b>Model</b>	Specifies the drive model of the selected device.								
<b>Drive Type</b>	Specifies the type of drive attached to the SATA port.								
<b>Capacity</b>	Specifies the total capacity of the hard drive. This field is undefined for removable media devices such as optical drives.								
<b>Port H</b>	<p>Sets the drive type of the selected device. For <b>Embedded SATA settings</b> in <b>ATA</b> mode, set this field to <b>Auto</b> to enable BIOS support. Set it to <b>OFF</b> to turn off BIOS support.</p> <p>For <b>AHCI</b> or <b>RAID</b> mode, BIOS support is always enabled.</p> <table border="1"> <thead> <tr> <th>Option</th> <th>Description</th> </tr> </thead> <tbody> <tr> <td><b>Model</b></td> <td>Specifies the drive model of the selected device.</td> </tr> <tr> <td><b>Drive Type</b></td> <td>Specifies the type of drive attached to the SATA port.</td> </tr> <tr> <td><b>Capacity</b></td> <td>Specifies the total capacity of the hard drive. This field is undefined for removable media devices such as optical drives.</td> </tr> </tbody> </table>	Option	Description	<b>Model</b>	Specifies the drive model of the selected device.	<b>Drive Type</b>	Specifies the type of drive attached to the SATA port.	<b>Capacity</b>	Specifies the total capacity of the hard drive. This field is undefined for removable media devices such as optical drives.
Option	Description								
<b>Model</b>	Specifies the drive model of the selected device.								
<b>Drive Type</b>	Specifies the type of drive attached to the SATA port.								
<b>Capacity</b>	Specifies the total capacity of the hard drive. This field is undefined for removable media devices such as optical drives.								
<b>Port I</b>	<p>Sets the drive type of the selected device. For <b>Embedded SATA settings</b> in <b>ATA</b> mode, set this field to <b>Auto</b> to enable BIOS support. Set it to <b>OFF</b> to turn off BIOS support.</p> <p>For <b>AHCI</b> or <b>RAID</b> mode, BIOS support is always enabled.</p> <table border="1"> <thead> <tr> <th>Option</th> <th>Description</th> </tr> </thead> <tbody> <tr> <td><b>Model</b></td> <td>Specifies the drive model of the selected device.</td> </tr> <tr> <td><b>Drive Type</b></td> <td>Specifies the type of drive attached to the SATA port.</td> </tr> <tr> <td><b>Capacity</b></td> <td>Specifies the total capacity of the hard drive. This field is undefined for removable media devices such as optical drives.</td> </tr> </tbody> </table>	Option	Description	<b>Model</b>	Specifies the drive model of the selected device.	<b>Drive Type</b>	Specifies the type of drive attached to the SATA port.	<b>Capacity</b>	Specifies the total capacity of the hard drive. This field is undefined for removable media devices such as optical drives.
Option	Description								
<b>Model</b>	Specifies the drive model of the selected device.								
<b>Drive Type</b>	Specifies the type of drive attached to the SATA port.								
<b>Capacity</b>	Specifies the total capacity of the hard drive. This field is undefined for removable media devices such as optical drives.								
<b>Port J</b>	<p>Sets the drive type of the selected device. For <b>Embedded SATA settings</b> in <b>ATA</b> mode, set this field to <b>Auto</b> to enable BIOS support. Set it to <b>OFF</b> to turn off BIOS support.</p> <p>For <b>AHCI</b> or <b>RAID</b> mode, BIOS support is always enabled.</p> <table border="1"> <thead> <tr> <th>Option</th> <th>Description</th> </tr> </thead> <tbody> <tr> <td><b>Model</b></td> <td>Specifies the drive model of the selected device.</td> </tr> <tr> <td><b>Drive Type</b></td> <td>Specifies the type of drive attached to the SATA port.</td> </tr> <tr> <td><b>Capacity</b></td> <td>Specifies the total capacity of the hard drive. This field is undefined for removable media devices such as optical drives.</td> </tr> </tbody> </table>	Option	Description	<b>Model</b>	Specifies the drive model of the selected device.	<b>Drive Type</b>	Specifies the type of drive attached to the SATA port.	<b>Capacity</b>	Specifies the total capacity of the hard drive. This field is undefined for removable media devices such as optical drives.
Option	Description								
<b>Model</b>	Specifies the drive model of the selected device.								
<b>Drive Type</b>	Specifies the type of drive attached to the SATA port.								
<b>Capacity</b>	Specifies the total capacity of the hard drive. This field is undefined for removable media devices such as optical drives.								

#### Related references

[SATA Settings](#) on page 46

### Related tasks

[Viewing SATA Settings](#) on page 46

## Integrated Devices

You can use the **Integrated Devices** screen to view and configure the settings of all integrated devices including the video controller, integrated RAID controller, and the USB ports.

### Related references

[System BIOS](#) on page 31

### Related tasks

[Integrated Devices details](#) on page 49

[Viewing Integrated Devices](#) on page 49

## Viewing Integrated Devices

To view the **Integrated Devices** screen, perform the following steps:

### Steps

1. Turn on, or restart your system.
2. Press F2 immediately after you see the following message:

```
F2 = System Setup
```

**NOTE:** If your operating system begins to load before you press F2, wait for the system to finish booting, and then restart your system and try again.

3. On the **System Setup Main Menu** screen, click **System BIOS**.
4. On the **System BIOS** screen, click **Integrated Devices**.

### Related references

[Integrated Devices](#) on page 49

### Related tasks

[Integrated Devices details](#) on page 49

## Integrated Devices details

### About this task

The **Integrated Devices** screen details are explained as follows:

Option	Description
<b>USB 3.0 Setting</b>	Enables or disables the USB 3.0 support. Enable this option only if your operating system supports USB 3.0. If you disable this option, devices operate at USB 2.0 speed. USB 3.0 is enabled by default.
<b>User Accessible USB Ports</b>	Enables or disables the USB ports. Selecting <b>Only Back Ports On</b> disables the front USB ports, selecting <b>All Ports Off</b> disables all USB ports. The USB keyboard and mouse operate during boot process in certain operating systems. After the boot process is complete, the USB keyboard and mouse do not work if the ports are disabled. <b>NOTE:</b> Selecting <b>Only Back Ports On</b> and <b>All Ports Off</b> disables the USB management port and also restricts access to iDRAC features.

Option	Description
<b>Internal USB Port</b>	Enables or disables the internal USB port. This option is set to <b>Enabled</b> by default.
<b>Integrated RAID Controller</b>	Enables or disables the integrated RAID controller. This option is set to <b>Enabled</b> by default.
<b>Integrated Network Card 1</b>	Enables or disables the integrated network card.
<b>Embedded NIC1 and NIC2</b>	<p> <b>NOTE:</b> The Embedded NIC1 and NIC2 options are only available on systems that do not have <b>Integrated Network Card 1</b>.</p> <p>Enables or disables the Embedded NIC1 and NIC2 options. If set to <b>Disabled</b>, the NIC may still be available for shared network access by the embedded management controller. The embedded NIC1 and NIC2 options are only available on systems that do not have Network Daughter Cards (NDCs). The Embedded NIC1 and NIC2 option is mutually exclusive with the Integrated Network Card 1 option. Configure the Embedded NIC1 and NIC2 option by using the NIC management utilities of the system.</p>
<b>I/OAT DMA Engine</b>	Enables or disables the I/OAT option. Enable only if the hardware and software support the feature.
<b>Embedded Video Controller</b>	Enables or disables the <b>Embedded Video Controller</b> option. This option is set to <b>Enabled</b> by default.
<b>Current State of Embedded Video Controller</b>	Displays the current state of the embedded video controller. The <b>Current State of Embedded Video Controller</b> option is a read-only field. If the Embedded Video Controller is the only display capability in the system (that is, no add-in graphics card is installed), then the Embedded Video Controller is automatically used as the primary display even if the <b>Embedded Video Controller</b> setting is set to <b>Disabled</b> .
<b>SR-IOV Global Enable</b>	Enables or disables the BIOS configuration of Single Root I/O Virtualization (SR-IOV) devices. This option is set to <b>Disabled</b> by default.
<b>OS Watchdog Timer</b>	If your system stops responding, this watchdog timer aids in the recovery of your operating system. When this option is set to <b>Enabled</b> , the operating system initializes the timer. When this option is set to <b>Disabled</b> (the default), the timer does not have any effect on the system.
<b>Memory Mapped I/O above 4 GB</b>	Enables or disables the support for PCIe devices that need large amounts of memory. This option is set to <b>Enabled</b> by default.
<b>Slot Disablement</b>	Enables or disables the available PCIe slots on your system. The slot disablement feature controls the configuration of PCIe cards installed in the specified slot. Slots must be disabled only when the installed peripheral card prevents booting into the operating system or causes delays in system startup. If the slot is disabled, both the Option ROM and UEFI drivers are disabled.

#### Related references

[Integrated Devices](#) on page 49

#### Related tasks

[Viewing Integrated Devices](#) on page 49

## Serial Communication

You can use the **Serial Communication** screen to view the properties of the serial communication port.

#### Related references

[System BIOS](#) on page 31

#### Related tasks

[Serial Communication details](#) on page 51

[Viewing Serial Communication](#) on page 51

## Viewing Serial Communication

To view the **Serial Communication** screen, perform the following steps:

### Steps

1. Turn on, or restart your system.
2. Press F2 immediately after you see the following message:

```
F2 = System Setup
```

**NOTE:** If your operating system begins to load before you press F2, wait for the system to finish booting, and then restart your system and try again.

3. On the **System Setup Main Menu** screen, click **System BIOS**.
4. On the **System BIOS** screen, click **Serial Communication**.

### Related references

[Serial Communication](#) on page 50

### Related tasks

[Serial Communication details](#) on page 51

## Serial Communication details

### About this task

The **Serial Communication** screen details are explained as follows:

Option	Description
<b>Serial Communication</b>	Selects serial communication devices (Serial Device 1 and Serial Device 2) in BIOS. BIOS console redirection can also be enabled and the port address can be specified. This option is set to <b>Auto</b> by default.
<b>Serial Port Address</b>	Enables you to set the port address for serial devices. This option is set to <b>Serial Device 1=COM2, Serial Device 2=COM1</b> by default. <b>NOTE:</b> You can use only Serial Device 2 for the Serial Over LAN (SOL) feature. To use console redirection by SOL, configure the same port address for console redirection and the serial device. <b>NOTE:</b> Every time the system boots, the BIOS syncs the serial MUX setting saved in iDRAC. The serial MUX setting can independently be changed in iDRAC. Loading the BIOS default settings from within the BIOS setup utility may not always revert the serial MUX setting to the default setting of Serial Device 1.
<b>External Serial Connector</b>	Enables you to associate the External Serial Connector to Serial Device 1, Serial Device 2, or the Remote Access Device by using this option. <b>NOTE:</b> Only Serial Device 2 can be used for Serial Over LAN (SOL). To use console redirection by SOL, configure the same port address for console redirection and the serial device. <b>NOTE:</b> Every time the system boots, the BIOS syncs the serial MUX setting saved in iDRAC. The serial MUX setting can independently be changed in iDRAC. Loading the BIOS default settings from within the BIOS setup utility may not always revert this setting to the default setting of Serial Device 1.
<b>Failsafe Baud Rate</b>	Specifies the failsafe baud rate for console redirection. The BIOS attempts to determine the baud rate automatically. This failsafe baud rate is used only if the attempt fails, and the value must not be changed. This option is set to <b>115200</b> by default.

Option	Description
<b>Remote Terminal Type</b>	Sets the remote console terminal type. This option is set to <b>VT 100/VT 220</b> by default.
<b>Redirection After Boot</b>	Enables or disables the BIOS console redirection when the operating system is loaded. This option is set to <b>Enabled</b> by default.

#### Related references

[Serial Communication](#) on page 50

#### Related tasks

[Viewing Serial Communication](#) on page 51

## System Profile Settings

You can use the **System Profile Settings** screen to enable specific system performance settings such as power management.

#### Related references

[System BIOS](#) on page 31

#### Related tasks

[System Profile Settings details](#) on page 52

[Viewing System Profile Settings](#) on page 52

## Viewing System Profile Settings

To view the **System Profile Settings** screen, perform the following steps:

#### Steps

1. Turn on, or restart your system.
2. Press F2 immediately after you see the following message:

```
F2 = System Setup
```

**NOTE:** If your operating system begins to load before you press F2, wait for the system to finish booting, and then restart your system and try again.

3. On the **System Setup Main Menu** screen, click **System BIOS**.
4. On the **System BIOS** screen, click **System Profile Settings**.

#### Related references

[System Profile Settings](#) on page 52

#### Related tasks

[System Profile Settings details](#) on page 52

## System Profile Settings details

#### About this task

The **System Profile Settings** screen details are explained as follows:

Option	Description
<b>System Profile</b>	<p>Sets the system profile. If you set the <b>System Profile</b> option to a mode other than <b>Custom</b>, the BIOS automatically sets the rest of the options. You can only change the rest of the options if the mode is set to <b>Custom</b>. This option is set to <b>Performance Optimized</b> by default.</p> <p> <b>NOTE:</b> All the parameters on the system profile setting screen are available only when the <b>System Profile</b> option is set to <b>Custom</b>.</p>
<b>CPU Power Management</b>	Sets the CPU power management. This option is set to <b>System DBPM (DAPC)</b> by default. DBPM is Demand-Based Power Management.
<b>Memory Frequency</b>	Sets the speed of the system memory. You can select <b>Maximum Performance</b> , <b>Maximum Reliability</b> , or a specific speed.
<b>Turbo Boost</b>	Enables or disables the processor to operate in the turbo boost mode. This option is set to <b>Enabled</b> by default.
<b>Energy Efficient Turbo</b>	<p>Enables or disables the <b>Energy Efficient Turbo</b> option.</p> <p>Energy Efficient Turbo (EET) is a mode of operation where a processor's core frequency is adjusted to be within the turbo range based on workload.</p>
<b>C1E</b>	Enables or disables the processor to switch to a minimum performance state when it is idle. This option is set to <b>Enabled</b> by default.
<b>C States</b>	Enables or disables the processor to operate in all available power states. This option is set to <b>Enabled</b> by default.
<b>Collaborative CPU Performance Control</b>	Enables or disables the CPU power management option. When set to <b>Enabled</b> , the CPU power management is controlled by the OS DBPM and the System DBPM (DAPC). This option is set to <b>Disabled</b> by default.
<b>Memory Patrol Scrub</b>	Sets the memory patrol scrub frequency. This option is set to <b>Standard</b> by default.
<b>Memory Refresh Rate</b>	Sets the memory refresh rate to either 1x or 2x. This option is set to <b>1x</b> by default.
<b>Uncore Frequency</b>	<p>Enables you to select the <b>Processor Uncore Frequency</b> option.</p> <p>Dynamic mode enables the processor to optimize power resources across the cores and uncore during runtime. The optimization of the uncore frequency to either save power or optimize performance is influenced by the setting of the <b>Energy Efficiency Policy</b> option.</p>
<b>Energy Efficient Policy</b>	<p>Enables you to select the <b>Energy Efficient Policy</b> option.</p> <p>The CPU uses the setting to manipulate the internal behavior of the processor and determines whether to target higher performance or better power savings.</p>
<b>Number of Turbo Boot Enabled Cores for Processor 1</b>	<p> <b>NOTE:</b> If there are two processors installed in the system, you see an entry for <b>Number of Turbo Boost Enabled Cores for Processor 2</b>.</p> <p>Controls the number of turbo boost enabled cores for processor 1. The maximum number of cores is enabled by default.</p>
<b>Monitor/Mwait</b>	<p>Enables the Monitor/Mwait instructions in the processor. This option is set to <b>Enabled</b> for all system profiles, except <b>Custom</b> by default.</p> <p> <b>NOTE:</b> This option can be disabled only if the <b>C States</b> option in the <b>Custom</b> mode is set to <b>disabled</b>.</p> <p> <b>NOTE:</b> When <b>C States</b> is set to <b>Enabled</b> in the <b>Custom</b> mode, changing the Monitor/Mwait setting does not impact the system power or performance.</p>

#### Related references

[System Profile Settings](#) on page 52

## Related tasks

[Viewing System Profile Settings](#) on page 52

# Miscellaneous Settings

You can use the **Miscellaneous Settings** screen to perform specific functions such as updating the asset tag and changing the system date and time.

## Related references

[System BIOS](#) on page 31

## Related tasks

[Miscellaneous Settings details](#) on page 54

[Viewing Miscellaneous Settings](#) on page 54

# Viewing Miscellaneous Settings

To view the **Miscellaneous Settings** screen, perform the following steps:

## Steps

1. Turn on, or restart your system.
2. Press F2 immediately after you see the following message:

```
F2 = System Setup
```

 **NOTE:** If your operating system begins to load before you press F2, wait for the system to finish booting, and then restart your system and try again.

3. On the **System Setup Main Menu** screen, click **System BIOS**.
4. On the **System BIOS** screen, click **Miscellaneous Settings**.

## Related references

[Miscellaneous Settings](#) on page 54

## Related tasks

[Miscellaneous Settings details](#) on page 54

# Miscellaneous Settings details

## About this task

The **Miscellaneous Settings** screen details are explained as follows:

Option	Description
<b>System Time</b>	Enables you to set the time on the system.
<b>System Date</b>	Enables you to set the date on the system.
<b>Asset Tag</b>	Specifies the asset tag and enables you to modify it for security and tracking purposes.
<b>Keyboard NumLock</b>	Enables you to set whether the system boots with the NumLock enabled or disabled. This option is set to <b>On</b> by default.  <b>NOTE:</b> This option does not apply to 84-key keyboards.
<b>F1/F2 Prompt on Error</b>	Enables or disables the F1/F2 prompt on error. This option is set to <b>Enabled</b> by default. The F1/F2 prompt also includes keyboard errors.

Option	Description
<b>Load Legacy Video Option ROM</b>	Enables you to determine whether the system BIOS loads the legacy video (INT 10H) option ROM from the video controller. Selecting <b>Enabled</b> in the operating system does not support UEFI video output standards. This field is available only for UEFI boot mode. You cannot set the option to <b>Enabled</b> if <b>UEFI Secure Boot</b> mode is enabled.

#### Related references

[Miscellaneous Settings](#) on page 54

#### Related tasks

[Viewing Miscellaneous Settings](#) on page 54

## iDRAC Settings utility

The iDRAC settings utility is an interface to set up and configure the iDRAC parameters by using UEFI. You can enable or disable various iDRAC parameters by using the iDRAC settings utility.

 **NOTE:** Accessing some of the features on the iDRAC settings utility needs the iDRAC Enterprise License upgrade.

For more information about using iDRAC, see *Dell Integrated Dell Remote Access Controller User's Guide* at [Dell.com/idracmanuals](http://Dell.com/idracmanuals).

#### Related concepts

[Device Settings](#) on page 56

#### Related references

[System BIOS](#) on page 31

#### Related tasks

[Entering the iDRAC Settings utility](#) on page 55

[Changing the thermal settings](#) on page 55

## Entering the iDRAC Settings utility

#### Steps

1. Turn on or restart the managed system.
2. Press F2 during Power-on Self-test (POST).
3. On the **System Setup Main Menu** page, click **iDRAC Settings**.  
The **iDRAC Settings** screen is displayed.

#### Related references

[iDRAC Settings utility](#) on page 55

## Changing the thermal settings

The iDRAC settings utility enables you to select and customize the thermal control settings for your system.

1. Click **iDRAC Settings > Thermal**.
2. Under **SYSTEM THERMAL PROFILE > Thermal Profile**, select one of the following options:
  - Default Thermal Profile Settings
  - Maximum Performance (Performance Optimized)
  - Minimum Power (Performance per Watt Optimized)
3. Under **USER COOLING OPTIONS**, set the **Fan Speed Offset**, **Minimum Fan Speed**, and **Custom Minimum Fan Speed**.

4. Click **Back** > **Finish** > **Yes**.

#### Related references

[iDRAC Settings utility](#) on page 55

## Device Settings

**Device Settings** enables you to configure device parameters.

#### Related references

[System BIOS](#) on page 31

## Dell Lifecycle Controller

Dell Lifecycle Controller (LC) provides advanced embedded systems management capabilities including system deployment, configuration, update, maintenance, and diagnosis. LC is delivered as part of the iDRAC out-of-band solution and Dell system embedded Unified Extensible Firmware Interface (UEFI) applications.

#### Related references

[Embedded system management](#) on page 56

## Embedded system management

The Dell Lifecycle Controller provides advanced embedded systems management throughout the system's lifecycle. The Dell Lifecycle Controller can be started during the boot sequence and can function independently of the operating system.

 **NOTE:** Certain platform configurations may not support the full set of features provided by the Dell Lifecycle Controller.

For more information about setting up the Dell Lifecycle Controller, configuring hardware and firmware, and deploying the operating system, see the Dell Lifecycle Controller documentation at [Dell.com/idracmanuals](https://www.dell.com/idracmanuals).

#### Related references

[Dell Lifecycle Controller](#) on page 56

## Boot Manager

The **Boot Manager** screen enables you to select boot options and diagnostic utilities.

#### Related references

[Boot Manager main menu](#) on page 57

[System BIOS](#) on page 31

#### Related tasks

[Viewing Boot Manager](#) on page 57

# Viewing Boot Manager

To enter **Boot Manager**:

## Steps

1. Turn on, or restart your system.
2. Press F11 when you see the following message:

```
F11 = Boot Manager
```

If your operating system begins to load before you press F11, allow the system to complete the booting, and then restart your system and try again.

## Related references

[Boot Manager](#) on page 56

[Boot Manager main menu](#) on page 57

# Boot Manager main menu

Menu item	Description
<b>Continue Normal Boot</b>	The system attempts to boot to devices starting with the first item in the boot order. If the boot attempt fails, the system continues with the next item in the boot order until the boot is successful or no more boot options are found.
<b>One-shot Boot Menu</b>	Enables you to access boot menu, where you can select a one-time boot device to boot from.
<b>Launch System Setup</b>	Enables you to access System Setup.
<b>Launch Lifecycle Controller</b>	Exits the Boot Manager and invokes the Dell Lifecycle Controller program.
<b>System Utilities</b>	Enables you to launch System Utilities menu such as System Diagnostics and UEFI shell.

## Related references

[Boot Manager](#) on page 56

## Related tasks

[Viewing Boot Manager](#) on page 57

# One-shot BIOS boot menu

**One-shot BIOS boot menu** enables you to select a one-shot boot device to boot from the following options:

- Launch Diagnostics
- BIOS Update File Explorer
- Reboot System

## Related references

[Boot Manager](#) on page 56

## System Utilities

**System Utilities** contains the following utilities that can be launched:

- Launch Diagnostics
- BIOS Update File Explorer
- Reboot System

### Related references

[Boot Manager](#) on page 56

## PXE boot

The Preboot Execution Environment (PXE) is an industry standard client or interface that allows networked computers that are not yet loaded with an operating system to be configured and booted remotely by an administrator.

# Installing and removing system components

This section provides information about installing and removing the system components.

## Topics:

- Safety instructions
- Before working inside your system
- After working inside your system
- Recommended tools
- Front bezel (optional)
- Removing the system cover
- Installing the system cover
- Inside the system
- Cooling shroud
- System memory
- Hard drives
- Optical drive (optional)
- Cooling fans
- Internal USB memory key (optional)
- Expansion cards and expansion card riser
- SD vFlash media card (optional)
- Integrated storage controller card
- Network daughter card
- Processors and heat sinks
- Power supply units
- System battery
- Hard drive backplane
- Control panel assembly
- VGA module
- System board
- Trusted Platform Module

## Safety instructions

 **NOTE:** Whenever you need to lift the system, get others to assist you. To avoid injury, do not attempt to lift the system by yourself.

 **WARNING:** Opening or removing the system cover while the system is powered on may expose you to a risk of electric shock.

 **CAUTION:** Do not operate the system without the cover for a duration exceeding five minutes.

 **CAUTION:** Many repairs may only be done by a certified service technician. You should only perform troubleshooting and simple repairs as authorized in your product documentation, or as directed by the online or telephone service and support team. Damage due to servicing that is not authorized by Dell is not covered by your warranty. Read and follow the safety instructions that are shipped with your product.

 **CAUTION:** Operating the system without the system cover can result in component damage.

 **NOTE:** Dell recommends that you always use a static mat and static strap while working on components inside the system.

 **NOTE:** To ensure proper operation and cooling, all bays in the system and system fans must be populated always with either a component or with a blank.

## Before working inside your system

### Prerequisites

Follow the safety guidelines listed in the Safety instructions section.

### Steps

1. Turn off the system, including any attached peripherals.
2. Disconnect the system from the electrical outlet and disconnect the peripherals.
3. If installed, remove the front bezel.
4. If applicable, remove the system from the rack.  
For more information, see the *Rack Installation* placemat at [Dell.com/sdscalityseriesmanuals](https://Dell.com/sdscalityseriesmanuals).
5. Remove the system cover.

### Related references

[Safety instructions](#) on page 59

## After working inside your system

### Prerequisites

Follow the safety guidelines listed in the Safety instructions section.

### Steps

1. Install the system cover.
2. If applicable, install the system into the rack.  
For more information, see the *Rack Installation* placemat at [Dell.com/sdscalityseriesmanuals](https://Dell.com/sdscalityseriesmanuals).
3. If removed, install the optional front bezel.
4. Reconnect the peripherals and connect the system to the electrical outlet.
5. Turn on the system, including any attached peripherals.

### Related references

[Safety instructions](#) on page 59

## Recommended tools

You need the following tools to perform the removal and installation procedures:

- Key to the bezel lock. This is needed only if your system includes a bezel.
- Phillips #1 screwdriver
- Phillips #2 screwdriver
- Wrist grounding strap

You need the following tools to assemble the cables for a DC power supply unit.

- AMP 90871-1 hand-crimping tool or equivalent
- Tyco Electronics 58433-3 or equivalent
- Wire-stripper pliers to remove insulation from size 10 AWG solid or stranded, insulated copper wire

 **NOTE:** Use alpha wire part number 3080 or equivalent (65/30 stranding).

# Front bezel (optional)

The front bezel is attached to the front side of the server and prevents accidents while removing the hard drive or when pressing the reset or power button. The front bezel can also be locked for additional security.

## Removing the optional front bezel

### Prerequisites

1. Follow the safety guidelines listed in the Safety instructions section.

### Steps

1. Locate and remove the bezel key.

**NOTE:** The bezel key is attached to the back of the bezel.

2. Unlock the bezel by using the key.
3. Slide the release latch up and pull the left end of the bezel.
4. Unhook the right end, and remove the bezel.

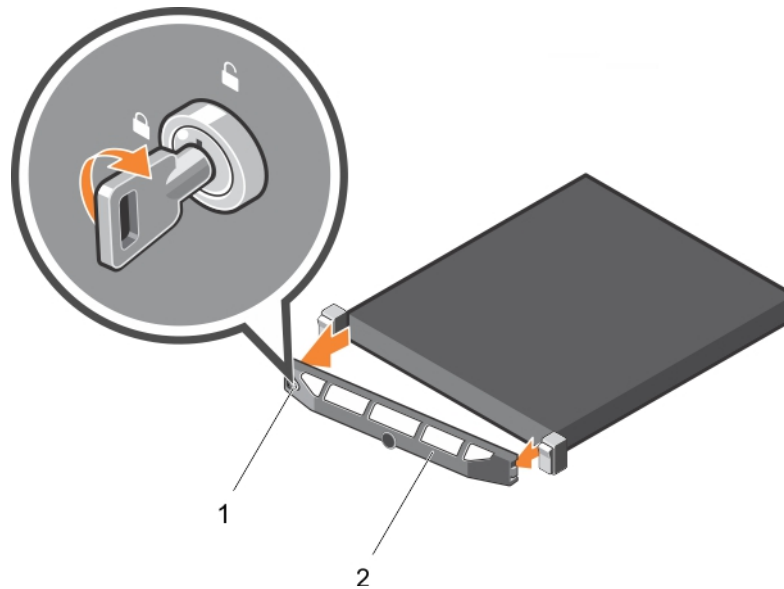

**Figure 11. Removing the optional front bezel**

- a. bezel lock
- b. front bezel

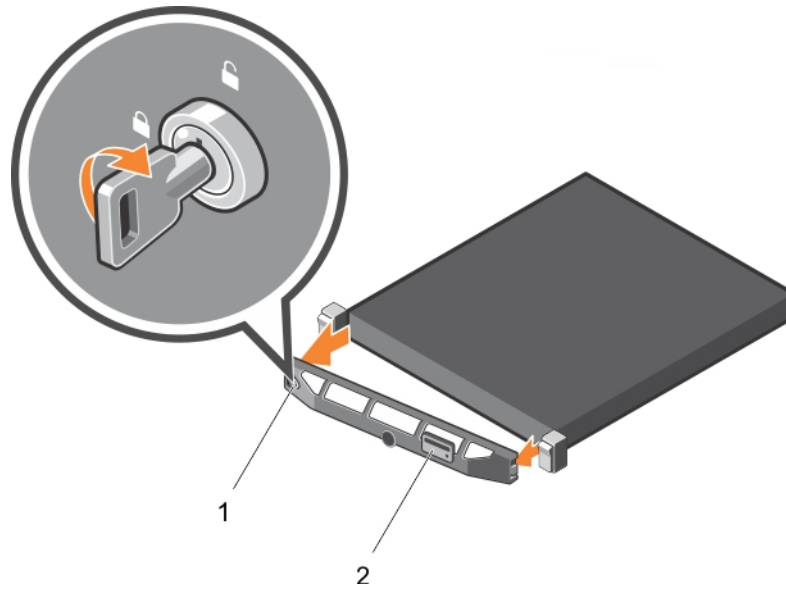

**Figure 12. Removing the Quick Sync bezel**

- a. bezel lock
- b. Quick Sync bezel

#### Related references

[Safety instructions](#) on page 59

## Installing the optional front bezel

#### Prerequisites

1. Follow the safety guidelines listed in the Safety instructions section.

#### Steps

1. Locate and remove the bezel key.

**NOTE:** The bezel key is attached to the back of the bezel.

2. Hook the right end of the bezel onto the chassis.
3. Fit the free end of the bezel onto the system.
4. Lock the bezel by using the key.

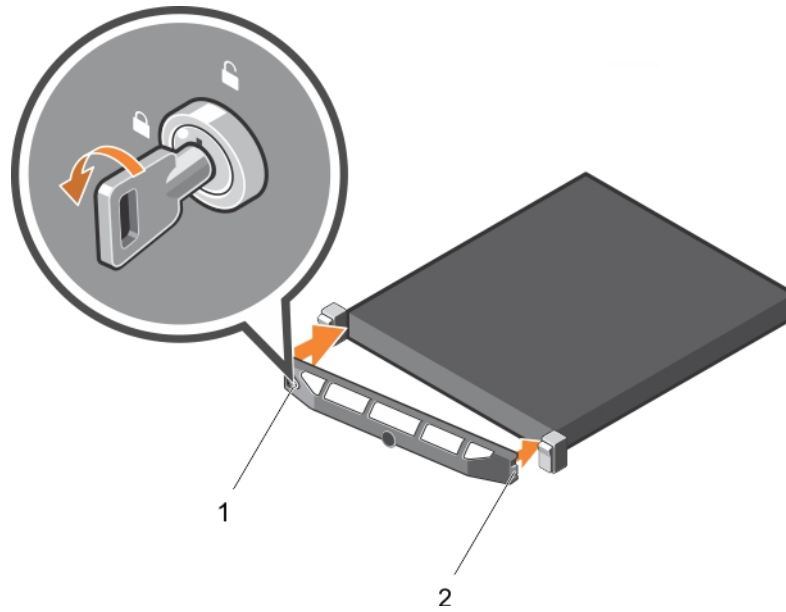

**Figure 13. Installing the optional front bezel**

- a. bezel lock
- b. front bezel

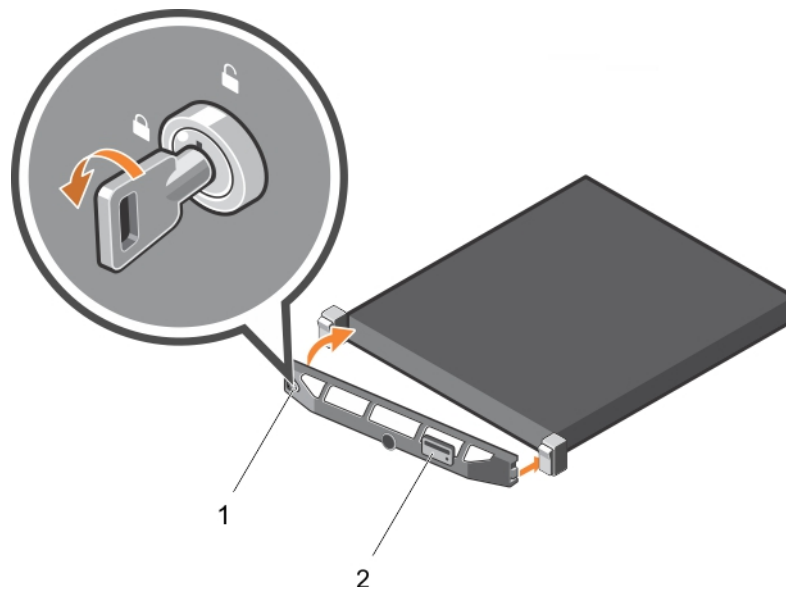

**Figure 14. Installing the Quick Sync bezel**

- a. bezel lock
- b. Quick Sync bezel

### Related references

[Safety instructions](#) on page 59

## Removing the system cover

### Prerequisites

1. Follow the safety guidelines listed in the Safety instructions section.
2. Turn off the system, including any attached peripherals.

3. Disconnect the system from the electrical outlet and disconnect the peripherals.
4. If installed, remove the optional bezel. For more information, see the Removing the optional front bezel section.

### Steps

1. Rotate the latch release lock counter clockwise to the unlocked position.
2. Lift the latch toward the back of the system.

The system cover slides back and the tabs on the system cover disengage from the slots on the chassis.

**i** **NOTE:** The position of the latch may vary depending on the configuration of your system.

3. Hold the cover on both sides, and lift the cover away from the system.

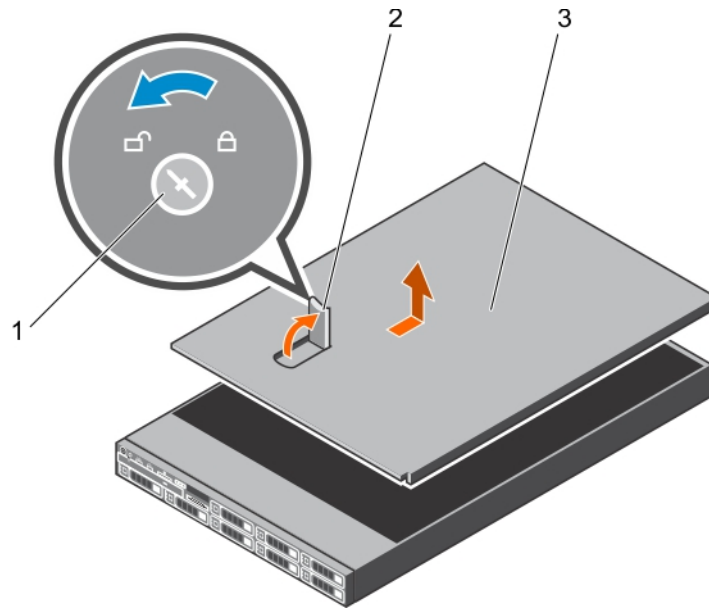

**Figure 15. Removing the system cover**

- a. latch release lock
- b. latch
- c. system cover

### Next steps

1. Install the system cover.

### Related references

[Safety instructions](#) on page 59

### Related tasks

[Removing the optional front bezel](#) on page 61

## Installing the system cover

### Prerequisites

1. Follow the safety guidelines listed in the Safety instructions section.
2. Ensure that all internal cables are connected and placed out of the way and no tools or extra parts are left inside the system.

### Steps

1. Align the slots on the system cover with the tabs on the chassis.

2. Push the system cover latch down to move the system cover into the closed position.  
The system cover slides forward and the tabs on the system cover engage with the slots on the chassis. The system cover latch locks into place when the system cover engages with the slots on the chassis.
3. Rotate the latch release lock clockwise to the locked position.

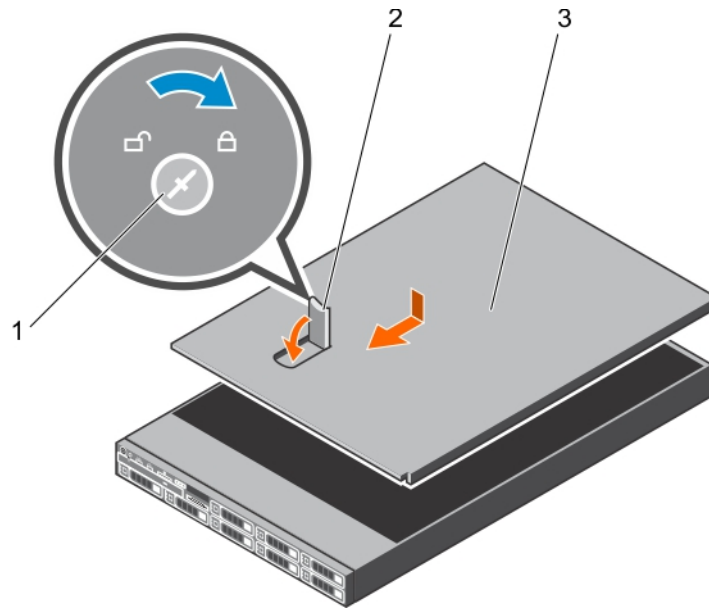

**Figure 16. Installing the system cover**

- a. latch release lock
- b. latch
- c. system cover

#### Next steps

1. If removed, install the bezel.
2. Reconnect the peripherals and connect the system to the electrical outlet.
3. Turn on the system, including any attached peripherals.

#### Related references

[Safety instructions](#) on page 59

## Inside the system

**CAUTION:** Many repairs may only be done by a certified service technician. You should only perform troubleshooting and simple repairs as authorized in your product documentation, or as directed by the online or telephone service and support team. Damage due to servicing that is not authorized by Dell is not covered by your warranty. Read and follow the safety instructions that are shipped with your product.

**NOTE:** Components that are hot swappable are marked orange and touch points on the components are marked blue.

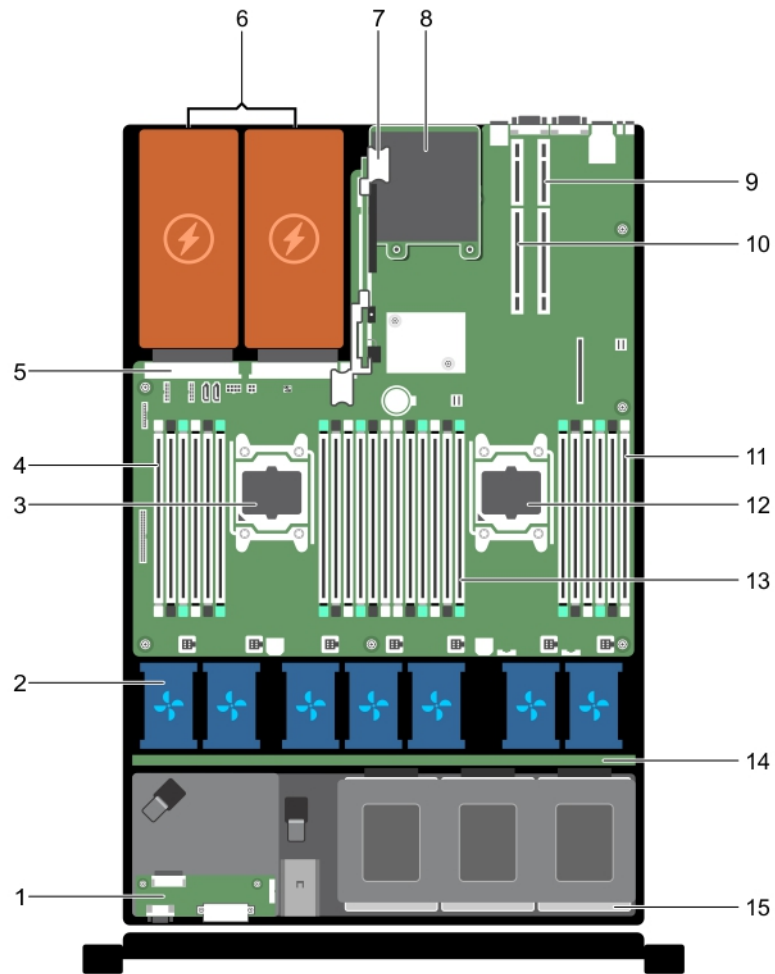

**Figure 17. Inside the system—eight hard drive system**

- |                                      |                          |
|--------------------------------------|--------------------------|
| 1. control panel assembly            | 2. cooling fans (7)      |
| 3. processor 1                       | 4. DIMMs (6)             |
| 5. power supply unit (PSU) connector | 6. PSU (2)               |
| 7. riser card 3                      | 8. network daughter card |
| 9. riser card 2                      | 10. riser card 1         |
| 11. DIMMs (6)                        | 12. processor 2          |
| 13. DIMMs (12)                       | 14. hard drive backplane |
| 15. hard drive                       |                          |

# Cooling shroud

The cooling shroud has aerodynamically placed openings that direct the airflow across the entire system. The airflow passes through all the critical parts of the system, where the vacuum pulls air across the entire surface area of the heat sink, thus allowing increased cooling.

## Removing the cooling shroud

### Prerequisites

**CAUTION:** Many repairs may only be done by a certified service technician. You should only perform troubleshooting and simple repairs as authorized in your product documentation, or as directed by the online or telephone service and support team. Damage due to servicing that is not authorized by Dell is not covered by your warranty. Read and follow the safety instructions that are shipped with your product.

1. Follow the safety guidelines listed in the Safety instructions section.
2. Follow the procedure listed in the Before working inside your system section.
3. If connected, disconnect the cables from expansion card (s).

**NOTE:** If required, close the expansion card latch on the cooling shroud to release the full length card.

4. If installed, remove the expansion card riser.

**CAUTION:** Never operate your system with the cooling shroud removed. The system may get overheated quickly, resulting in shutdown of the system and loss of data.

### Steps

By holding the sides of the cooling shroud, lift the cooling shroud away from the system.

### Next steps

1. Reinstall the cooling shroud.
2. If removed, reinstall the optional PCIe expansion card riser.
3. If disconnected, connect the cables to the expansion card(s).
4. If required, open the expansion-card latch on the cooling shroud to support the full length expansion card.
5. Follow the procedure listed in the After working inside your system section.

### Related references

[Safety instructions](#) on page 59

### Related tasks

[Before working inside your system](#) on page 60

[After working inside your system](#) on page 60

## Installing the cooling shroud

### Prerequisites

**CAUTION:** Many repairs may only be done by a certified service technician. You should only perform troubleshooting and simple repairs as authorized in your product documentation, or as directed by the online or telephone service and support team. Damage due to servicing that is not authorized by Dell is not covered by your warranty. Read and follow the safety instructions that are shipped with your product.

1. Follow the safety guidelines listed in the Safety instructions section.
2. Follow the procedure listed in the Before working inside your system section.
3. If applicable, route the cables inside the system along the chassis wall and secure the cables by using the cable-securing bracket.

## Steps

1. Align the tabs on the cooling shroud with the securing slots on the chassis.
2. Lower the cooling shroud into the chassis until it is firmly seated.

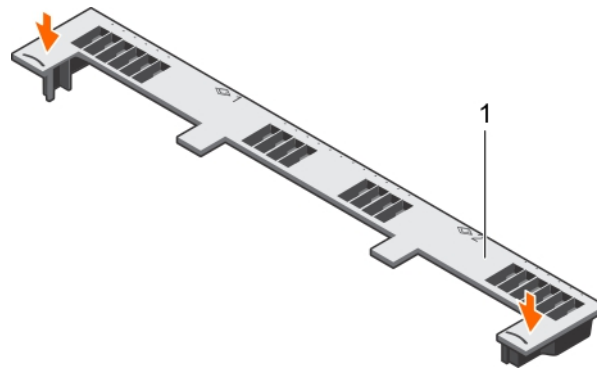

**Figure 18. Installing the cooling shroud**

a. cooling shroud

## Next steps

1. Follow the procedure listed in the After working inside your system section.

## Related references

[Safety instructions](#) on page 59

## Related tasks

[Before working inside your system](#) on page 60

[After working inside your system](#) on page 60

# System memory

The system supports DDR4 registered DIMMs (RDIMMs). System memory holds the instructions that the processor runs and data with which instructions work with. System memory is an important part of the main processing subsystem of the PC, with the processor, cache, system board and chipset.

**NOTE:** MT/s indicates DIMM speed in MegaTransfers per second.

Memory bus operating frequency can be 1866 MT/s, 2133 MT/s, or 2400 MT/s depending on the following factors:

- DIMM type (RDIMM)
- Number of DIMMs populated per channel
- System profile selected (for example, Performance Optimized, Custom, or Dense Configuration Optimized)
- Maximum supported DIMM frequency of the processors

Your system contains 24 memory sockets split into two sets of 12 sockets, one set per processor. Each 12-socket set is organized into four channels. In each channel, the release tabs of the first socket are marked white, the second socket black, and the third socket green.

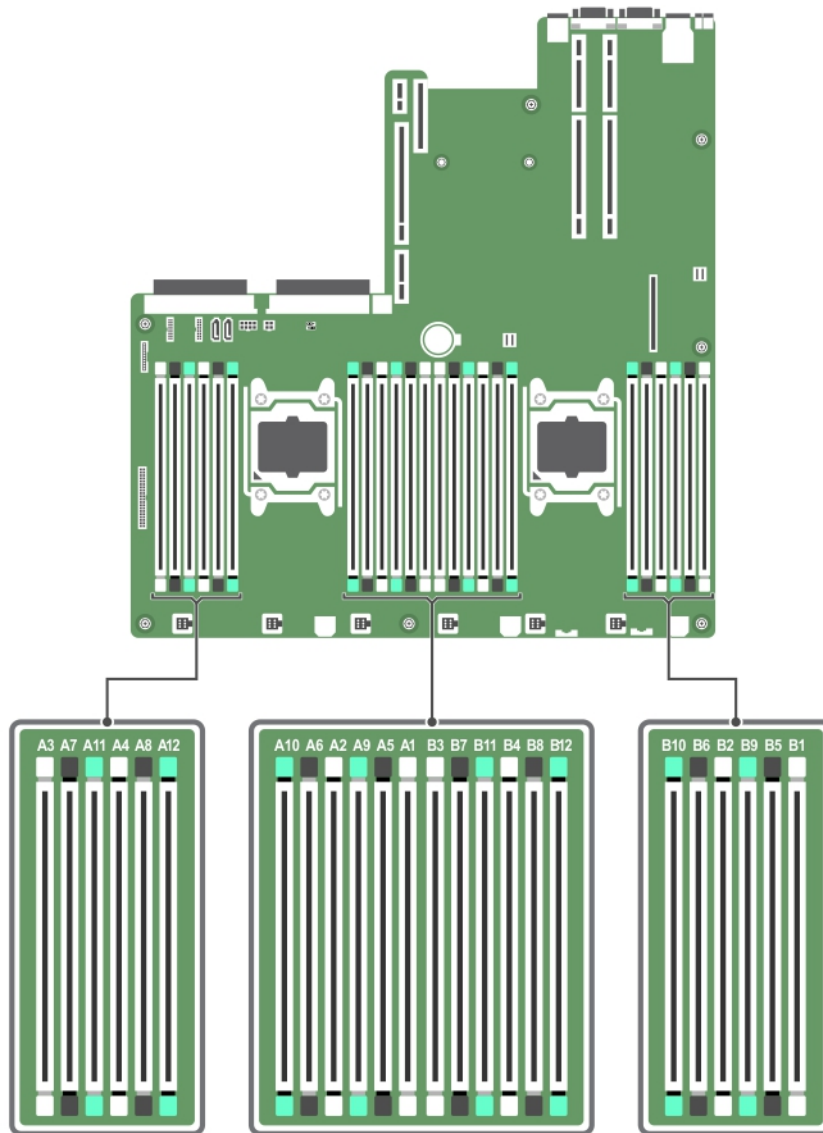

**Figure 19. Memory socket locations**

Memory channels are organized as follows:

**Table 30. Memory channels**

Processor	Channel 0	Channel 1	Channel 2	Channel 3
Processor 1	Slots A1, A5, and A9	Slots A2, A6, and A10	Slots A3, A7, and A11	Slots A4, A8, and A12
Processor 2	Slots B1, B5, and B9	Slots B2, B6, and B10	Slots B3, B7, and B11	Slots B4, B8, and B12

The following table shows the memory populations and operating frequencies for the supported configurations:

**Table 31. Memory population**

DIMM Type	DIMMs Populated/ Channel	Voltage	Operating Frequency (in MT/s)	Maximum DIMM Rank/ Channel
RDIMM	1	1.2 V	2400, 2133, 1866	Dual rank or single rank
	2		2400, 2133, 1866	Dual rank or single rank
	3		2400, 2133, 1866	Dual rank or single rank

## General memory module installation guidelines

**NOTE:** Memory configurations that fail to observe these guidelines can prevent your system from booting, stop responding during memory configuration, or operating with reduced memory.

The system supports Flexible Memory Configuration, enabling the system to be configured and run in any valid chipset architectural configuration. The following are the recommended guidelines for installing memory modules:

- x4 and x8 DRAM-based memory modules can be mixed. For more information, see the Mode-specific guidelines section.
- Up to three dual- or single-rank RDIMMs can be populated per channel.
- If memory modules with different speeds are installed, they operate at the speed of the slowest installed memory modules or slower depending on system DIMM configuration.
- Populate memory module sockets only if a processor is installed. For single-processor systems, sockets A1 to A12 are available. For dual-processor systems, sockets A1 to A12 and sockets B1 to B12 are available.
- Populate all the sockets with white release tabs first, followed by the black release tabs, and then the green release tabs.
- Populate the sockets by highest rank count in the following order—first in sockets with white release levers, then black, and then green. For example, if you want to mix single-rank and dual-rank memory modules, populate dual-rank memory modules in the sockets with white release tabs and single-rank memory modules in the sockets with black release tabs.
- When mixing memory modules with different capacities, populate the sockets with memory modules with highest capacity first. For example, if you want to mix 4 GB and 8 GB memory modules, populate 8 GB memory modules in the sockets with white release tabs and 4 GB memory modules in the sockets with black release tabs.
- In a dual-processor configuration, the memory configuration for each processor should be identical. For example, if you populate socket A1 for processor 1 then populate socket B1 for processor 2, and so on.
- Memory modules of different capacities can be mixed provided other memory population rules are followed (for example, 8 GB and 16 GB memory modules can be mixed).
- Mixing of more than two memory module capacities in a system is not supported.
- Populate four memory modules per processor (one DIMM per channel) at a time to maximize performance.

## Mode-specific guidelines

Four memory channels are allocated to each processor. The allowable configurations depend on the memory mode selected. Dell recommends to set the memory to Memory Optimized mode.

**NOTE:** You can mix x4 and x8 DRAM based DIMMs to support RAS features. However, all guidelines for specific RAS features must be followed. x4 DRAM based DIMMs retain Single Device Data Correction (SDDC) in memory optimized (independent channel) mode. x8 DRAM based DIMMs need Advanced ECC mode to gain SDDC.

## Advanced Error Correction Code (lockstep)

Advanced Error Correction Code (ECC) mode extends SDDC from x4 DRAM based DIMMs to both x4 and x8 DRAMs. This protects against single DRAM chip failures during normal operation.

The installation guidelines for memory modules are as follows:

- Memory modules must be identical in size, speed, and technology.
- DIMMs installed in memory sockets with white release levers must be identical and the same rule applies for sockets with black release levers. This ensures that identical DIMMs are installed in matched pair—for example, A1 with A2, A3 with A4, A5 with A6, and so on.

## Memory optimized (independent channel) mode

This mode supports Single Device Data Correction (SDDC) only for memory modules that use x4 device width. It does not impose any specific slot population requirements.

## Memory sparing

**NOTE:** To use memory sparing, this feature must be enabled in System Setup.

In this mode, one rank per channel is reserved as a spare. If persistent correctable errors are detected on a rank, the data from this rank is copied to the spare rank, and the failed rank is disabled.

With memory sparing enabled, the system memory available to the operating system is reduced by one rank per channel. For example, in a dual-processor configuration with sixteen 4 GB quad-rank memory modules, the available system memory is: 3/4 (ranks/channel) × 16 (memory modules) × 4 GB = 48 GB, and not 16 (memory modules) × 4 GB = 64 GB.

**NOTE:** Memory sparing does not offer protection against a multi-bit uncorrectable error.

**NOTE:** Both Advanced ECC/Lockstep and Optimizer modes support memory sparing.

## Memory mirroring

Memory mirroring offers the strongest memory module reliability mode compared to all other modes, providing improved uncorrectable multi-bit failure protection. In a mirrored configuration, the total available system memory is one half of the total installed physical memory. Half of the installed memory is used to mirror the active memory modules. In the event of an uncorrectable error, the system switches over to the mirrored copy. This ensures SDDC and multi-bit protection.

The installation guidelines for memory modules are as follows:

- Memory modules must be identical in size, speed, and technology.
- Memory modules installed in memory module sockets with white release levers must be identical and the same rule applies for sockets with black and green release tabs. This ensures that identical memory modules are installed in matched pairs—for example, A1 with A2, A3 with A4, A5 with A6, and so on.

**Table 32. Processor configuration**

Processor	Configuration	Memory population rules	Memory population information
Single CPU	Memory population order	{1,2}, {3,4}	See Memory mirroring note

## Sample memory configurations

The following tables show sample memory configurations for one and two processor configurations that follow the appropriate memory guidelines.

**NOTE:** 1R, 2R, and 4R in the following tables indicate single, dual, and quad-rank DIMMs respectively.

**Table 33. Memory configurations—single processor**

System capacity (in GB)	DIMM size (in GB)	Number of DIMMs	DIMM rank, organization, and frequency	DIMM slot population
32	8	4	2R, x8, 2133 MT/s	A1, A2, A3, A4
			2R, x8, 1866 MT/s	
			2R, x8, 2400 MT/s	
48	8	6	2R, x8, 2133 MT/s	A1, A2, A3, A4, A5, A6
			2R, x8, 1866 MT/s	
			2R, x8, 2400 MT/s	
64	8	8	2R, x8, 2133 MT/s	A1, A2, A3, A4, A5, A6, A7, A8
			2R, x8, 1866 MT/s	
			2R, x8, 2400 MT/s	
96	8	12	2R, x8, 1866 MT/s	A1, A2, A3, A4, A5, A6, A7, A8, A9, A10, A11, A12
			2R, x8, 2400 MT/s	
	16	6	2R, x4, 2133 MT/s	A1, A2, A3, A4, A5, A6
			2R, x4, 1866 MT/s	

**Table 33. Memory configurations—single processor (continued)**

System capacity (in GB)	DIMM size (in GB)	Number of DIMMs	DIMM rank, organization, and frequency	DIMM slot population
			2R, x4, 2400 MT/s	
128	16	8	2R, x4, 2133 MT/s 2R, x4, 1866 MT/s 2R, x4, 2400 MT/s	A1, A2, A3, A4, A5, A6, A7, A8
144	16 and 8	10	2R, x4 and 2R, x8, 1866 MT/s 2R, x4 and 2R, x8, 2400 MT/s	A1, A2, A3, A4, A5, A6, A7, A8, A9, A11*
256	32	8	2R, x4, 2133 MT/s 2R, x4, 2400 MT/s	A1, A2, A3, A4, A5, A6, A7, A8
384	32	12	2R, x4, 1866 MT/s 2R, x4, 2400 MT/s	A1, A2, A3, A4, A5, A6, A7, A8, A9, A10, A11, A12

\* 16 GB DIMMs must be installed in slots numbered A1, A2, A3, A4, A5, A6, A7, and A8 and 8 GB DIMMs must be installed in slots A9 and A11.

**Table 34. Memory configurations—two processors**

System capacity (in GB)	DIMM size (in GB)	Number of DIMMs	DIMM rank, organization, and frequency	DIMM slot population
64	8	8	2R, x8, 2133 MT/s, 2R, x8, 1866 MT/s 2R, x8, 2400 MT/s	A1, A2, A3, A4, B1, B2, B3, B4
96	8	12	2R, x8, 2133 MT/s, 2R, x8, 1866 MT/s 2R, x8, 2400 MT/s	A1, A2, A3, A4, A5, A6, B1, B2, B3, B4, B5, B6
128	8	16	2R, x8, 2133 MT/s 2R, x8, 1866 MT/s 2R, x8, 2400 MT/s	A1, A2, A3, A4, A5, A6, A7, A8, B1, B2, B3, B4, B5, B6, B7, B8
	16	8	2R, x4, 2133 MT/s, 2R, x4, 1866 MT/s 2R, x4, 2400 MT/s	A1, A2, A3, A4, B1, B2, B3, B4
160	8	20	2R, x8, 1866 MT/s 2R, x8, 2400 MT/s	A1, A2, A3, A4, A5, A6, A7, A8, A9, A11, B1, B2, B3, B4, B5, B6, B7, B8, B9, B11
	16 and 8	12	2R, x4, 2133 MT/s, 2R, x8, 2133 MT/s, 2R, x4, 1866 MT/s 2R, x8, 1866 MT/s 2R, x4, 2400 MT/s 2R, x8, 2400 MT/s	A1, A2, A3, A4, A5, A6, B1, B2, B3, B4, B5, B6 *

**Table 34. Memory configurations—two processors (continued)**

System capacity (in GB)	DIMM size (in GB)	Number of DIMMs	DIMM rank, organization, and frequency	DIMM slot population
192	8	24	2R, x8, 1866 MT/s 2R, x8, 2400 MT/s	A1, A2, A3, A4, A5, A6, A7, A8, A9, A10, A11, A12, B1, B2, B3, B4, B5, B6, B7, B8, B9, B10, B11, B12
	16	12	2R, x4, 2133 MT/s, 2R, x4, 1866 MT/s 2R, x4, 2400 MT/s	A1, A2, A3, A4, A5, A6, B1, B2, B3, B4, B5, B6
	16	16	2R, x4, 2133 MT/s, 2R, x4, 1866 MT/s, 2R, x4, 2400 MT/s,	A1, A2, A3, A4, A5, A6, A7, A8, B1, B2, B3, B4, B5, B6, B7, B8
384	16	24	2R, x4, 1866 MT/s, 2R, x4, 2400 MT/s,	A1, A2, A3, A4, A5, A6, A7, A8, A9, A10, A11, A12, B1, B2, B3, B4, B5, B6, B7, B8, B9, B10, B11, B12
	32	12	2R, x4, 2133 MT/s 2R, x4, 2400 MT/s	A1, A2, A3, A4, A5, A6, B1, B2, B3, B4, B5, B6
512	32	16	4R, x4, 2133 MT/s 4R, x4, 2400 MT/s	A1, A2, A3, A4, A5, A6, A7, A8, B1, B2, B3, B4, B5, B6, B7, B8
768	32	24	2R, x4, 1866 MT/s 2R, x4, 2400 MT/s	A1, A2, A3, A4, A5, A6, A7, A8, A9, A10, A11, A12, B1, B2, B3, B4, B5, B6, B7, B8, B9, B10, B11, B12

\* 16 GB DIMMs must be installed in slots numbered A1, A2, A3, A4, B1, B2, B3, and B4 and 8 GB DIMMs must be installed in slots A5, A6, B5, and B6.

## Removing memory modules

### Prerequisites

**CAUTION:** Many repairs may only be done by a certified service technician. You should only perform troubleshooting and simple repairs as authorized in your product documentation, or as directed by the online or telephone service and support team. Damage due to servicing that is not authorized by Dell is not covered by your warranty. Read and follow the safety instructions that are shipped with your product.

1. Follow the safety guidelines listed in the Safety instructions section.
2. Follow the procedure listed in the Before working inside your system section.
3. Remove the cooling shroud.

**NOTE:** The memory modules are hot to touch for some time after the system has been powered down. Allow the memory modules to cool before handling them. Handle the memory modules by the card edges and avoid touching the components or metallic contacts on the memory module.

**CAUTION:** To ensure proper system cooling, memory module blanks must be installed in any memory socket that is not occupied. Remove memory module blanks only if you intend to install memory modules in those sockets.

### Steps

1. Locate the appropriate memory module socket.

**CAUTION:** Handle each memory module only by the card edges, ensuring not to touch the middle of the memory module or metallic contacts.

2. To release the memory module from the socket, simultaneously press the ejectors on both ends of the memory module socket.
3. Lift and remove the memory module from the system.

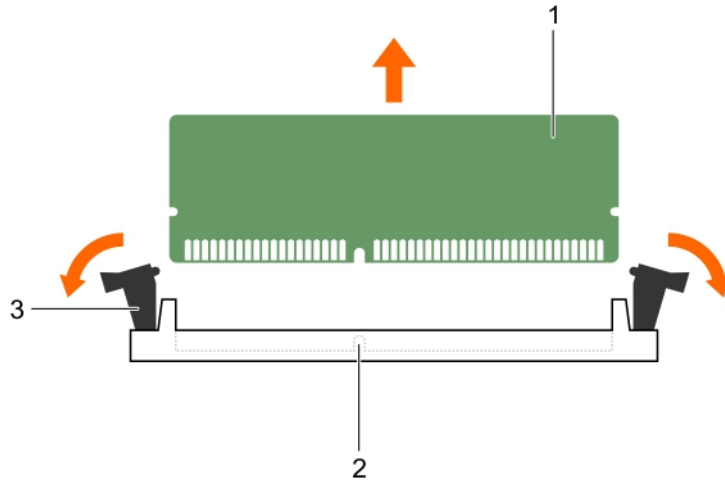

**Figure 20. Removing the memory module**

- a. memory module
- b. memory module socket
- c. memory module socket ejector (2)

### Next steps

1. If you are removing the memory module permanently, install a memory-module blank.
2. Install the memory module.
3. Install the cooling shroud.
4. Follow the procedure listed in the After working inside your system section.

### Related references

[Safety instructions](#) on page 59

### Related tasks

[Before working inside your system](#) on page 60

[After working inside your system](#) on page 60

## Installing memory modules

### Prerequisites

**CAUTION:** Many repairs may only be done by a certified service technician. You should only perform troubleshooting and simple repairs as authorized in your product documentation, or as directed by the online or telephone service and support team. Damage due to servicing that is not authorized by Dell is not covered by your warranty. Read and follow the safety instructions that are shipped with your product.

1. Follow the safety guidelines listed in the Safety instructions section.
2. Follow the procedure listed in the Before working inside your system section.

3. Remove the cooling shroud.
4. Removing the cooling fan assembly.

**NOTE:** The memory modules are hot to touch for some time after the system has been powered down. Allow the memory modules to cool before handling them. Handle the memory modules by the card edges and avoid touching the components or metallic contacts on the memory module.

**CAUTION:** To ensure proper system cooling, memory module blanks must be installed in any memory socket that is not occupied. Remove memory module blanks only if you intend to install memory modules in those sockets.

### Steps

1. Locate the appropriate memory module socket.

**CAUTION:** Handle each memory module only by the card edges, ensuring not to touch the middle of the memory module or metallic contacts.

2. Align the edge connector of the memory module with the alignment key of the memory module socket, and insert the memory module in the socket.

**CAUTION:** Do not apply pressure at the center of the memory module; apply pressure at both ends of the memory module evenly.

**NOTE:** The memory module socket has an alignment key that enables you to install the memory module in the socket in only one orientation.

3. Press the memory module with your thumbs until the socket levers firmly click into place.  
When the memory module is properly seated in the socket, the levers on the memory module socket align with the levers on the other sockets that have memory modules installed.

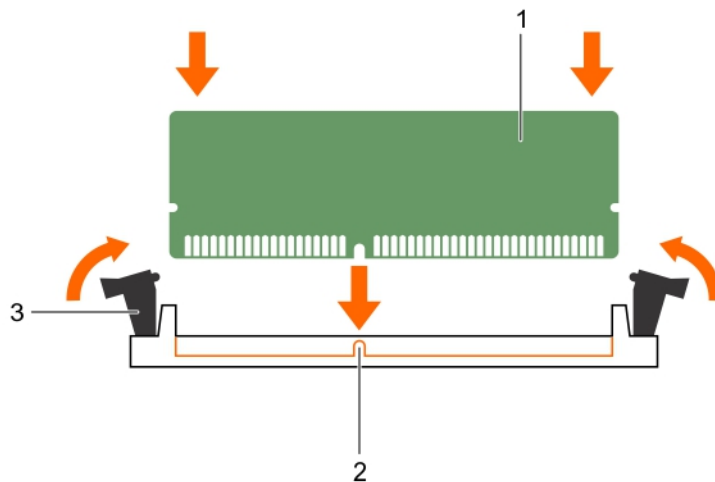

**Figure 21. Installing the memory module**

- a. memory module
- b. alignment key
- c. memory module socket ejector (2)

### Next steps

1. Install the cooling shroud.
2. Follow the procedure listed in the After working inside your system section.
3. Press F2 to enter System Setup, and check the **System Memory** setting.

The system should have already changed the value to reflect the installed memory.

4. If the value is incorrect, one or more of the memory modules may not be installed properly. Ensure that the memory module is firmly seated in the memory module socket.
5. Run the system memory test in system diagnostics.

#### Related references

[Safety instructions](#) on page 59

#### Related tasks

[Before working inside your system](#) on page 60

[After working inside your system](#) on page 60

## Hard drives

All hard drives connect to the system board through the hard drive backplane. Hard drives are supplied in hot swappable hard drive carriers that fit in the hard drive slots.

**CAUTION:** Before attempting to remove or install a hard drive while the system is running, see the documentation for the storage controller card to ensure that the host adapter is configured correctly to support hot swappable hard drive removal and insertion.

**CAUTION:** Do not turn off or reboot your system while the hard drive is being formatted. Doing so can cause a hard drive failure.

**NOTE:** Use only hard drives that have been tested and approved for use with the hard drive backplane.

When you format a hard drive, allow enough time for the formatting to be completed. High-capacity hard drives can take several hours to format.

## Removing a 2.5-inch hard drive blank

#### Prerequisites

**CAUTION:** Many repairs may only be done by a certified service technician. Perform troubleshooting and simple repairs as authorized in your product documentation, or as directed by the online or telephone service and support team. Damage due to servicing that is not authorized by Dell is not covered by your warranty. Read and follow the safety instructions that came with the product.

**CAUTION:** To maintain proper system cooling, all empty hard drive slots must have hard drive blanks installed.

1. Follow the safety guidelines listed in the Safety instructions section.
2. If installed, remove the bezel.

#### Steps

Press the release button and slide the hard drive blank out of the hard drive slot.

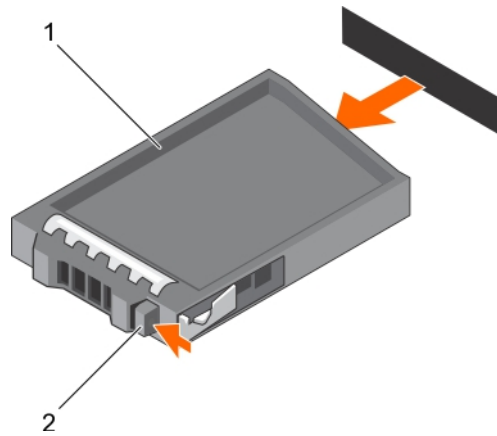

**Figure 22. Removing a 2.5-inch hard drive blank**

- a. hard drive blank
- b. release button

**Related references**

[Safety instructions](#) on page 59

## Installing a 2.5-inch hard drive blank

**Prerequisites**

- 1. Follow the safety guidelines listed in the Safety instructions section.
- 2. If installed, remove the front bezel.

**Steps**

Insert the hard drive blank into the hard drive slot until the release button clicks into place.

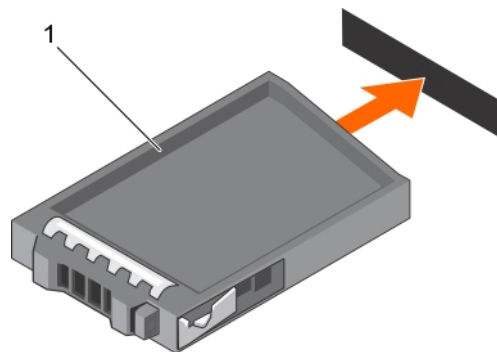

**Figure 23. Installing a 2.5-inch hard drive blank**

- a. hard drive blank

**Next steps**

If removed, install the front bezel.

**Related references**

[Safety instructions](#) on page 59

# Removing a hot swappable hard drive or SSD

## Prerequisites

**CAUTION:** Many repairs may only be done by a certified service technician. You must perform troubleshooting and simple repairs as authorized in your product documentation, or as directed by the online or telephone service and support team. Damage due to servicing that is not authorized by Dell is not covered by your warranty. Read and follow the safety instructions that came with the product.

1. Follow the safety guidelines listed in the Safety instructions section.
2. Follow the procedure listed in the Before working inside your system section.
3. If applicable, remove the bezel.
4. Using the management software, prepare the hard drive for removal. If the hard drive is online, the green activity or fault indicator flashes while the drive is turning off. When the hard drive indicators are off, the hard drive is ready for removal.

For more information, see the documentation for the storage controller.

**CAUTION:** To prevent data loss, ensure that your operating system supports hot-swap drive installation. See the documentation supplied with your operating system.

## Steps

1. To open the hard drive or SSD carrier release handle, press the release button.
2. Slide the hard drive carrier or SSD out of the hard drive slot.

**CAUTION:** To maintain proper system cooling, all empty hard drive or SSD slots must have hard drive or SSD blanks installed.

3. If you are not replacing the hard drive or SSD immediately, insert a hard drive or SSD blank in the empty hard drive slot.

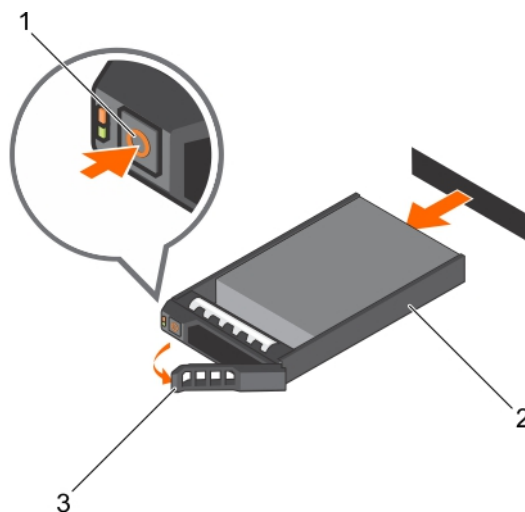

**Figure 24. Removing a hot swappable hard drive or SSD**

- a. release button
- b. hard drive or SSD carrier
- c. hard drive or SSD carrier handle

## Related references

[Safety instructions](#) on page 59

## Related tasks

[Before working inside your system](#) on page 60

# Installing a hot swappable hard drive

## Prerequisites

- CAUTION:** Many repairs may only be done by a certified service technician. You should only perform troubleshooting and simple repairs as authorized in your product documentation, or as directed by the online or telephone service and support team. Damage due to servicing that is not authorized by Dell is not covered by your warranty. Read and follow the safety instructions that are shipped with your product.
- CAUTION:** Use only hard drives that have been tested and approved for use with the hard drive backplane.
- CAUTION:** Combining SAS and SATA hard drives in the same RAID volume is not supported.
- CAUTION:** When installing a hard drive, ensure that the adjacent drives are fully installed. Inserting a hard drive carrier and attempting to lock its handle next to a partially installed carrier can damage the partially installed carrier's shield spring and make it unusable.
- CAUTION:** To prevent data loss, ensure that your operating system supports hot-swap drive installation. See the documentation supplied with your operating system.
- CAUTION:** When a replacement hot swappable hard drive is installed and the system is powered on, the hard drive automatically begins to rebuild. Make absolutely sure that the replacement hard drive is blank or contains data that you wish to have over-written. Any data on the replacement hard drive is immediately lost after the hard drive is installed.

1. Follow the safety guidelines listed in Safety instructions section.

## Steps

1. If a hard drive blank is installed in the hard drive slot, remove it.
2. Install a hard drive in the hard drive carrier. For more information, see the Installing a hot swappable hard drive into a hot swappable hard drive carrier section.
3. Press the release button on the front of the hard drive carrier and open the hard drive carrier handle.
4. Insert the hard drive carrier into the hard drive slot until the carrier connects with the backplane.
5. To lock the hard drive in place, close the hard drive carrier handle.

## Next steps

Install the optional front bezel.

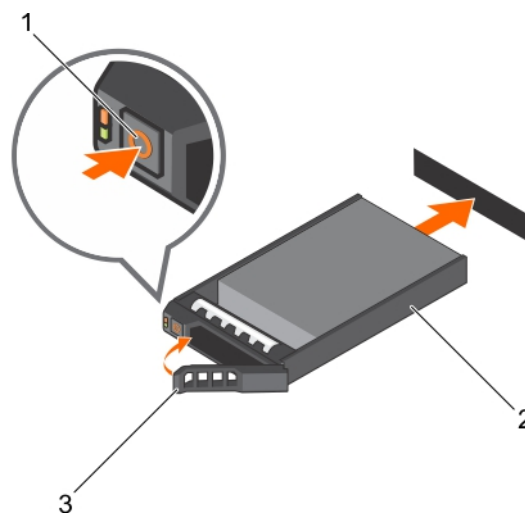

**Figure 25. Installing a hot swappable hard drive**

1. release button
2. hard drive or SSD carrier
3. hard drive or SSD carrier handle

## Related references

[Safety instructions](#) on page 59

## Related tasks

[Installing a hot swappable hard drive into a hot swappable hard drive carrier](#) on page 80

# Removing a hard drive from a hard drive carrier

## Prerequisites

1. Keep the Phillips #1 screwdriver handy.
2. Remove the hard drive carrier from the system.

## Steps

1. Remove the screws from the slide rails on the hard drive carrier.
2. Lift the hard drive out of the hard drive carrier.

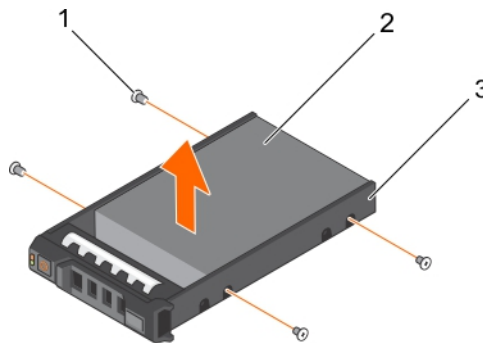

**Figure 26. Removing a hard drive into a hard drive carrier**

- a. screw (4)
- b. hard drive
- c. hard drive carrier

# Installing a hot swappable hard drive into a hot swappable hard drive carrier

## Prerequisites

**CAUTION:** Many repairs may only be done by a certified service technician. You should only perform troubleshooting and simple repairs as authorized in your product documentation, or as directed by the online or telephone service and support team. Damage due to servicing that is not authorized by Dell is not covered by your warranty. Read and follow the safety instructions that are shipped with your product.

**NOTE:** Hot swappable hard drives are supplied in hot swappable hard drive carriers that fit in the hard drive slots.

1. Keep the Phillips #2 screwdriver ready.
2. Remove the hot swappable hard drive carrier.

## Steps

1. Insert the hot swappable hard drive into the hard drive carrier with the connector end of the hard drive toward the back.
2. Align the screw holes on the hard drive with the set of screw holes on the hard drive carrier.  
When aligned correctly, the back of the hard drive is flush with the back of the hard drive carrier.
3. Attach the screws to secure the hard drive to the hard drive carrier.

### Next steps

Install the hard drive carrier into the system.

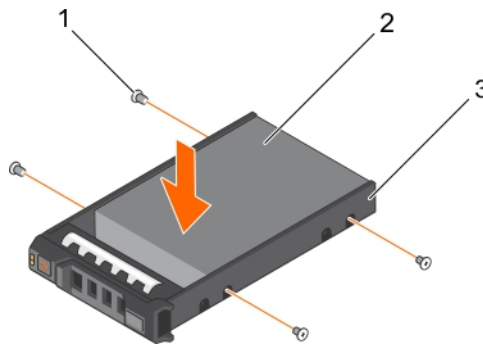

**Figure 27. Installing a hot swappable hard drive into a hot swappable hard drive carrier**

1. screw (4)
2. hard drive
3. hard drive carrier

## Optical drive (optional)

Optical drives retrieve and store data on optical discs such as compact disks (CD), digital versatile disks (DVD), and Blu-ray discs (BD). Optical drives can be categorized into two basic types: optical disk readers and optical disk writers.

### Removing the optional optical drive

#### Prerequisites

**CAUTION:** Many repairs may only be done by a certified service technician. You should only perform troubleshooting and simple repairs as authorized in your product documentation, or as directed by the online or telephone service and support team. Damage due to servicing that is not authorized by Dell is not covered by your warranty. Read and follow the safety instructions that are shipped with your product.

**NOTE:** This procedure applies only to the eight hard drive system.

1. Follow the safety guidelines listed in the Safety instructions section.
2. Follow the procedure listed in the Before working inside your system section.

#### Steps

1. Disconnect the power and data cable from the back of the drive.

**NOTE:** Ensure that you note the routing of the power and data cable on the side of the system as you remove them from the system board and drive. Route these cables properly when you replace them to prevent them from being pinched or crimped.

2. To release the optical drive, press the release tab.
3. Slide the optical drive out of the system until it is free of the optical drive slot.
4. If you are not adding a new optical drive, install the optical drive blank.

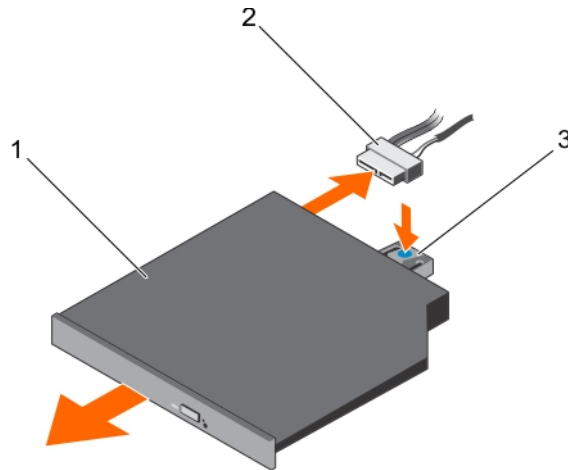

**Figure 28. Removing the optional optical drive**

- a. optical drive
- b. power and data cable
- c. release tab

### Next steps

Follow the procedure listed in the After working inside your system section.

### Related references

[Safety instructions](#) on page 59

### Related tasks

[Before working inside your system](#) on page 60

[After working inside your system](#) on page 60

## Installing the optional optical drive

### Prerequisites

**CAUTION:** Many repairs may only be done by a certified service technician. You should only perform troubleshooting and simple repairs as authorized in your product documentation, or as directed by the online or telephone service and support team. Damage due to servicing that is not authorized by Dell is not covered by your warranty. Read and follow the safety instructions that are shipped with your product.

**NOTE:** This procedure applies only to the eight hard drive system.

1. Follow the safety guidelines listed in the Safety instructions section.
2. Follow the procedure listed in the Before working inside your system section.

### Steps

1. Align the optical drive with the optical drive slot on the front of the chassis.
2. Slide in the optical drive until the release tab snaps into place.
3. Connect the power and data cable to the optical drive and system board.

**NOTE:** Route the cable properly on the side of the system to prevent it from being pinched or crimped.

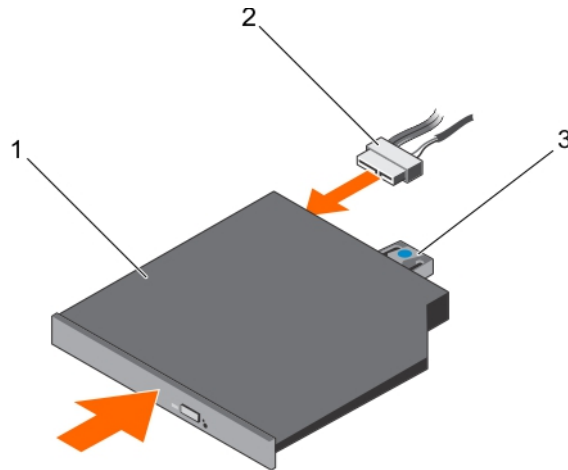

**Figure 29. Installing the optional optical drive**

- a. optical drive
- b. power and data cable
- c. release tab

### Next steps

Follow the procedure listed in the After working inside your system section.

### Related references

[Safety instructions](#) on page 59

### Related tasks

[Before working inside your system](#) on page 60

[After working inside your system](#) on page 60

## Removing the slim optical drive blank

To remove the slim optical drive, follow the same procedure.

### Prerequisites

**CAUTION:** Many repairs may only be done by a certified service technician. You should only perform troubleshooting and simple repairs as authorized in your product documentation, or as directed by the online or telephone service and support team. Damage due to servicing that is not authorized by Dell is not covered by your warranty. Read and follow the safety instructions that are shipped with your product.

1. Follow the safety guidelines listed in the Safety instructions section.
2. Follow the procedure listed in the Before working inside your system section.

### Steps

1. Locate the touch point for the slim optical drive blank lock inside the system.
2. Press the lock and pull the slim optical drive blank out of the chassis.

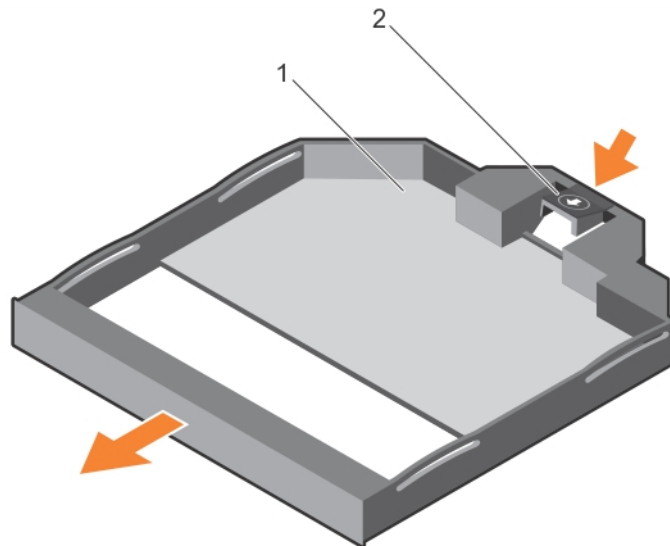

**Figure 30. Removing the slim optical drive blank**

- a. slim optical drive blank
- b. optical drive blank lock

#### Related references

[Safety instructions](#) on page 59

#### Related tasks

[Before working inside your system](#) on page 60

## Installing the slim optical drive blank

#### Prerequisites

**CAUTION:** Many repairs may only be done by a certified service technician. You should only perform troubleshooting and simple repairs as authorized in your product documentation, or as directed by the online or telephone service and support team. Damage due to servicing that is not authorized by Dell is not covered by your warranty. Read and follow the safety instructions that are shipped with your product.

Follow the safety instructions listed in the Safety instructions section.

#### Steps

1. Align the slim optical drive blank with the slim optical drive bay.
2. Slide the optical drive blank into the optical drive bay until the lock clicks into place.

#### Next steps

Follow the procedure listed in the After working inside your system section.

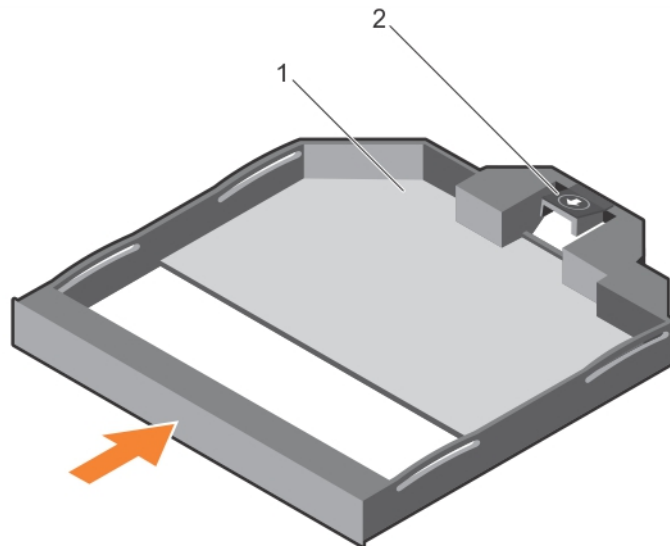

**Figure 31. Installing the slim optical drive blank**

1. slim optical drive blank
2. optical drive blank lock

**Related references**

[Safety instructions](#) on page 59

**Related tasks**

[After working inside your system](#) on page 60

## Cooling fans

Your system supports seven hot swappable cooling fans.

**NOTE:** In the event of a problem with a particular fan, the fan number is referenced by the system management software, allowing you to easily identify and replace the proper fan by noting the fan numbers on the cooling fan assembly.

## Removing a cooling fan

**Prerequisites**

**NOTE:** Opening or removing the system cover when the system is ON may expose you to a risk of electric shock. Exercise utmost care while removing or installing cooling fans.

**CAUTION:** Many repairs may only be done by a certified service technician. You should only perform troubleshooting and simple repairs as authorized in your product documentation, or as directed by the online or telephone service and support team. Damage due to servicing that is not authorized by Dell is not covered by your warranty. Read and follow the safety instructions that are shipped with your product.

**CAUTION:** The cooling fans are hot swappable. To maintain proper cooling while the system is on, replace only one fan at a time.

**CAUTION:** Do not operate the system with the cover removed for a duration exceeding five minutes.

**NOTE:** The procedure for removing each fan is identical.

1. Follow the safety guidelines listed in the Safety instructions section.
2. Follow the procedure listed in the Before working inside your system section.

## Steps

Hold the fan and lift it out of the system.

## Next steps

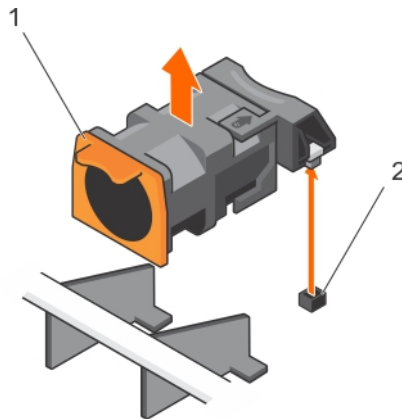

**Figure 32. Removing a cooling fan**

1. cooling fan (7)
2. connector on the system board (7)

## Related references

[Safety instructions](#) on page 59

## Related tasks

[Before working inside your system](#) on page 60

# Installing a cooling fan

## Prerequisites

**CAUTION:** Many repairs may only be done by a certified service technician. You should only perform troubleshooting and simple repairs as authorized in your product documentation, or as directed by the online or telephone service and support team. Damage due to servicing that is not authorized by Dell is not covered by your warranty. Read and follow the safety instructions that are shipped with your product.

1. Follow the safety guidelines listed in the Safety instructions section.
2. Follow the procedure listed in the Before working inside your system section.

**NOTE:** Your system supports seven hot-swappable cooling fans.

**NOTE:** The procedure for installing each fan is identical.

## Steps

1. Align the connector at the base of the cooling fan with the connector on the system board.
2. Slide the cooling fan into the securing slot until the tab locks into place.

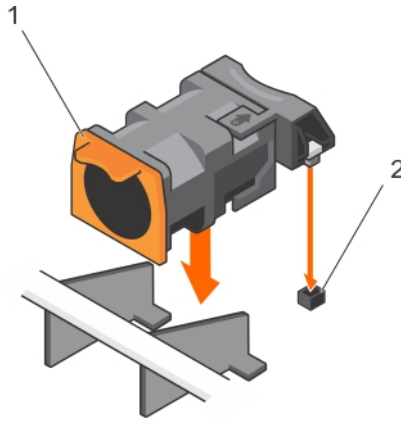

**Figure 33. Installing a cooling fan**

- a. cooling fan (7)
- b. connector on the system board (7)

### Next steps

Follow the procedure listed in the After working inside your system section.

### Related references

[Safety instructions](#) on page 59

### Related tasks

[Before working inside your system](#) on page 60

[After working inside your system](#) on page 60

## Internal USB memory key (optional)

An optional USB memory key installed inside your system can be used as a boot device, security key, or mass storage device.

To boot from the USB memory key, configure the USB memory key with a boot image and then specify the USB memory key in the boot sequence in System Setup.

The internal USB port must be enabled in **Internal USB Port** option in the **Integrated Devices** screen of **System Setup**.

**NOTE:** To locate the internal USB port J\_USB\_INT on the system board, see the System board jumpers and connectors section.

### Related references

[Jumpers and connectors](#) on page 130

## Replacing the optional internal USB memory key

### Prerequisites

**CAUTION:** Many repairs may only be done by a certified service technician. You should only perform troubleshooting and simple repairs as authorized in your product documentation, or as directed by the online or telephone service and support team. Damage due to servicing that is not authorized by Dell is not covered by your warranty. Read and follow the safety instructions that are shipped with your product.

1. Follow the safety guidelines listed in the Safety instructions section.
2. Follow the procedure listed in the Before working inside your system section.

### Steps

1. Locate the USB port or USB memory key on the system board.  
To locate the USB port, see the System board jumpers and connectors section.
2. If installed, remove the USB memory key from the USB port.

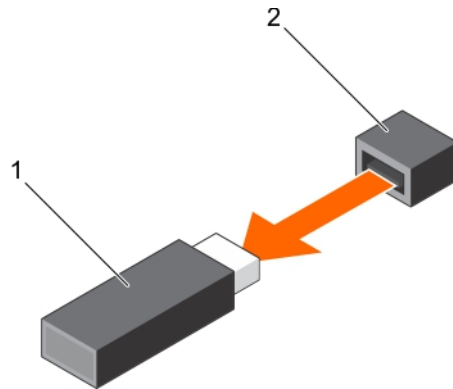

**Figure 34. Removing the internal USB memory key**

- a. USB memory key
- b. USB port

3. Insert the replacement USB memory key into the USB port.

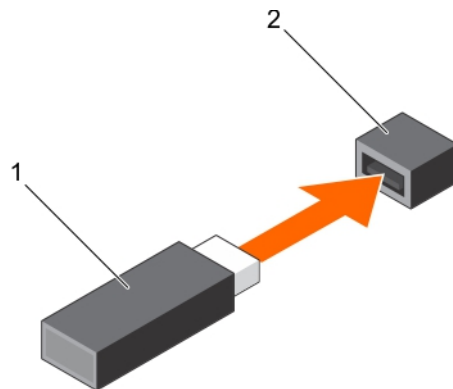

**Figure 35. Installing the internal USB memory key**

- a. USB memory key
- b. USB port

### Next steps

1. Follow the procedure listed in the After working inside your system section.
2. While booting, press F2 to enter System Setup and verify that the system detects the USB memory key.

### Related references

[Jumpers and connectors](#) on page 130

### Related tasks

- [Before working inside your system](#) on page 60  
[After working inside your system](#) on page 60

# Expansion cards and expansion card riser

An expansion card in the computer is an add-on card that can be inserted into an expansion slot on the computer system board or riser card to add enhanced functionality to the system through the expansion bus.

**NOTE:** A System Event Log (SEL) event is logged if an expansion card riser is unsupported or missing. It does not prevent your system from turning on and no BIOS POST message or F1/F2 pause is displayed.

## Expansion card installation guidelines

Your system supports PCI Express Generation 3 expansion cards.

**Table 35. Guidelines for systems supporting two PCIe expansion cards**

Riser	PCIe Slot	Processor Connection	Height	Length	Link Width	Slot Width
2	1	Processor 1	Low Profile	Half Length	x8	x16
		Processor 2	Low Profile	Half Length	x16	x16
3	2	Processor 1	Full height	Three-fourth Length	x16	x16

**NOTE:** Only a three-fourth length card is supported for the PCIe expansion card slot (slot 2) on riser 3 when no mini-PERC card is installed. Supported length with mini-PERC card installed is half length.

**NOTE:** For a system with three PCIe cards, only MiniSAS HD third-party cards are supported in slot 3. For a system with two PCIe cards, only MiniSAS HD third-party cards are supported in slot 1.

**NOTE:** You can install expansion cards only on one slot on riser 2.

**NOTE:** Both the processors must be installed to use the x16 PCIe link on the riser 2 slot.

The following table provides a guide for installing expansion cards to ensure proper cooling and mechanical fit. Install the expansion card by following the card priority and slot priority order as shown in the table.

**NOTE:** To support x16 PCIe link width, the 100 G HCA/OPA HFI in slot 1 needs processor 2 and x16 center\_riser2.

**Table 36. Expansion-card installation priority**

Card Priority	Card Type	Systems Supporting up to 2 PCIe Expansion Cards	
		Slot Priority	Max Allowed
1	PCIe Bridge	N/A	N/A
2	RAID	1	1
3	Infiniband HCA	1	1
4	40 G NICs	2, 1	2
5	FC16 HBA	2, 1	2
6	10 Gb NICs	2, 1	2
7	FC8 HBA	2, 1	2
8	1 Gb NICs	2, 1	2
9	Non-RAID	1	1
10	Integrated RAID	Integrated Slot	1
11	NDC	Integrated Slot	1
12	NVMe PCIe SSD	1	1

# Removing an expansion card

## Prerequisites

1. Follow the safety guidelines listed in Safety instructions section.
2. Follow the procedure listed in the Before working inside your system section.

**CAUTION:** Many repairs may only be done by a certified service technician. You must perform troubleshooting and simple repairs as authorized in your product documentation, or as directed by the online or telephone service and support team. Damage due to servicing that is not authorized by Dell is not covered by your warranty. Read and follow the safety instructions that came with the product.

## Steps

1. Disconnect any cables connected to the expansion card or expansion card riser.
2. To remove the expansion card, lift the expansion-card latch.
3. Grasp the expansion card by its edges and remove it from the expansion-card connector on the riser.
4. If you are removing the card permanently, install a metal filler bracket over the empty expansion slot opening and close the expansion-card latch.

**NOTE:** Install a filler bracket over an empty expansion slot to maintain Federal Communications Commission (FCC) certification of the system. The brackets also keep dust and dirt out of the system and aid in proper cooling and airflow inside the system.

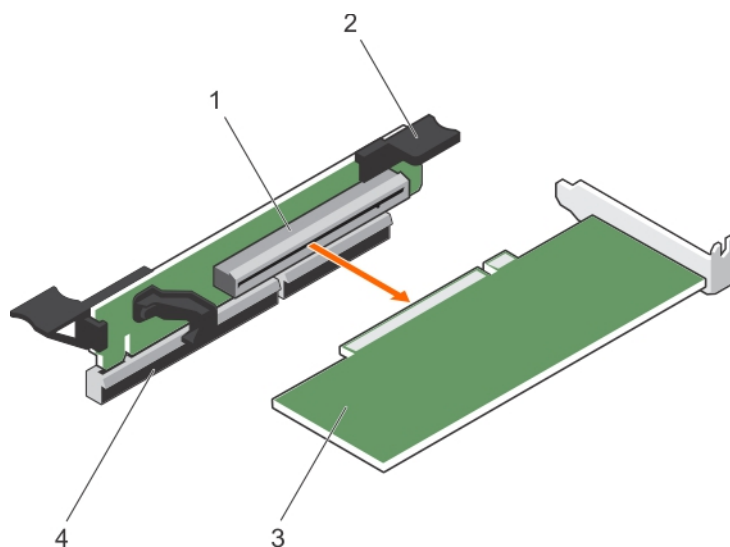

**Figure 36. Removing and installing the expansion card**

- |                        |                         |
|------------------------|-------------------------|
| 1. expansion connector | 2. expansion card latch |
| 3. expansion-card      | 4. expansion-card latch |

## Next steps

Follow the procedure listed in the After working inside your system section.

## Related references

[Safety instructions](#) on page 59

## Related tasks

[Before working inside your system](#) on page 60

[After working inside your system](#) on page 60

# Installing an expansion card

## Prerequisites

**CAUTION:** Many repairs may only be done by a certified service technician. You should only perform troubleshooting and simple repairs as authorized in your product documentation, or as directed by the online or telephone service and support team. Damage due to servicing that is not authorized by Dell is not covered by your warranty. Read and follow the safety instructions that are shipped with your product.

**NOTE:** The expansion card riser 1 and the x16 link on the riser 2 slot can be used only when both the processors are installed.

1. Follow the safety guidelines listed in the Safety instructions section.
2. Follow the procedure listed in the Before working inside your system section.
3. Remove the expansion card riser.

## Steps

1. Unpack the expansion card and prepare it for installation.  
For instructions, see the documentation that accompanied the card.
2. Locate the expansion card connector on the system board or riser.
3. Open the expansion card latch and remove the filler bracket.
4. Holding the card by its edges, position the card so that the card edge connector aligns with the expansion card connector.
5. Insert the card edge connector firmly into the expansion card connector until the card is fully seated.
6. Slide the expansion card latch into position.

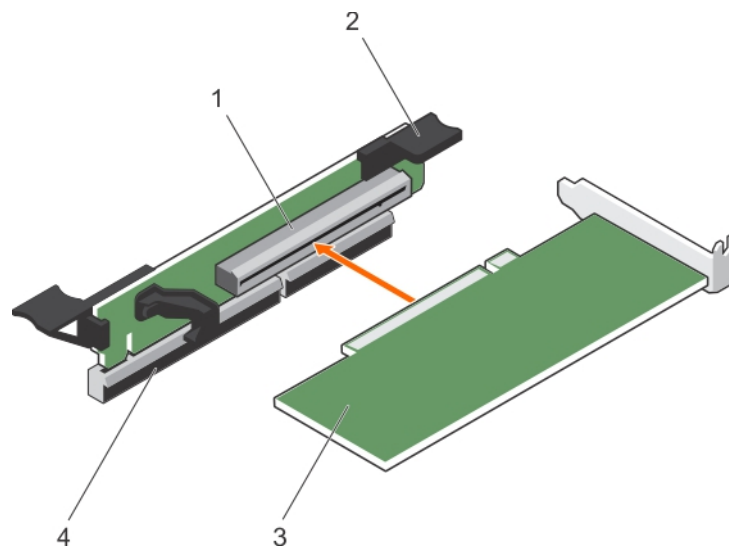

**Figure 37. Installing an expansion card**

- |                             |   |
|-----------------------------|---|
| 1. expansion card connector | 2. expansion card latch                         |
| 3. expansion card           | 4. expansion card connector on the system board |

7. Follow the procedure listed in the After working inside your system section.
8. Install any device drivers needed for the card as described in the documentation for the card.

## Related references

[Safety instructions](#) on page 59

## Related tasks

[Before working inside your system](#) on page 60

[After working inside your system](#) on page 60

# Removing expansion card risers

## Prerequisites

1. Follow the safety guidelines listed in the Safety instructions section.
2. Follow the procedure listed in the Before working inside your system section.

**CAUTION:** Many repairs may only be done by a certified service technician. You should only perform troubleshooting and simple repairs as authorized in your product documentation, or as directed by the online or telephone service and support team. Damage due to servicing that is not authorized by Dell is not covered by your warranty. Read and follow the safety instructions that are shipped with your product.

**NOTE:** The expansion card riser 1 and the x16 link on the riser 2 slot can be used only when both the processors are installed.

## Steps

1. Holding the touch points, lift the expansion card riser from the riser connector on the system board.

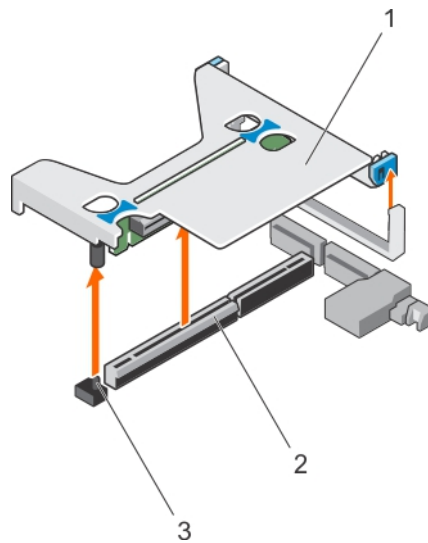

**Figure 38. Removing the expansion card riser 1**

- a. expansion card riser 1
- b. connector
- c. riser guide pin

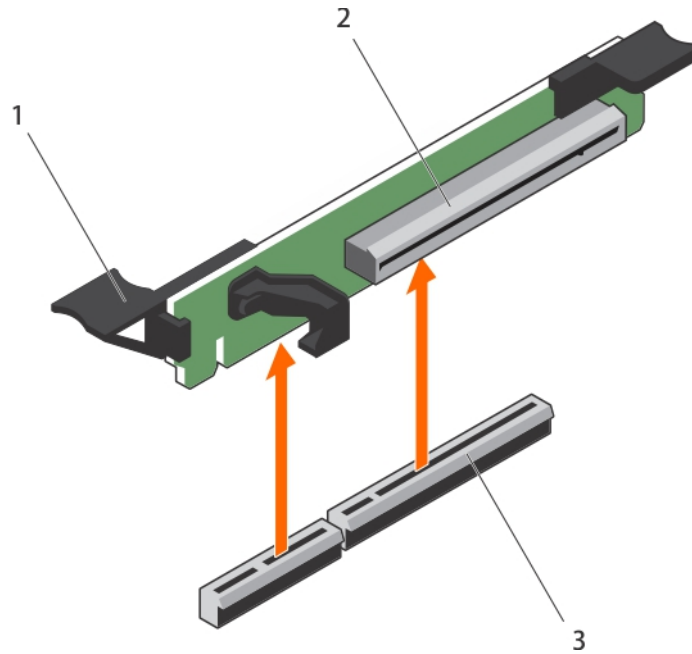

**Figure 39. Removing the expansion card riser 3**

- a. expansion card release latch
- b. expansion card riser 3
- c. connector

2. If applicable, remove or install an expansion card on the riser.
3. Install the expansion card riser.

**Next steps**

Follow the procedure listed in the After working inside your system section.

**Related references**

[Safety instructions](#) on page 59

**Related tasks**

[Before working inside your system](#) on page 60

[After working inside your system](#) on page 60

## Installing expansion card risers

**Prerequisites**

**CAUTION:** Many repairs may only be done by a certified service technician. You should only perform troubleshooting and simple repairs as authorized in your product documentation, or as directed by the online or telephone service and support team. Damage due to servicing that is not authorized by Dell is not covered by your warranty. Read and follow the safety instructions that are shipped with your product.

1. Follow the safety guidelines listed in the Safety instructions section.
2. Follow the procedure listed in the Before working inside your system section.

**Steps**

1. If removed, install the expansion cards into the expansion card riser.
2. Align the expansion card riser with the connector and the riser guide pin on the system board.
3. Lower the expansion card riser into place until the expansion card riser connector is fully seated in the connector.

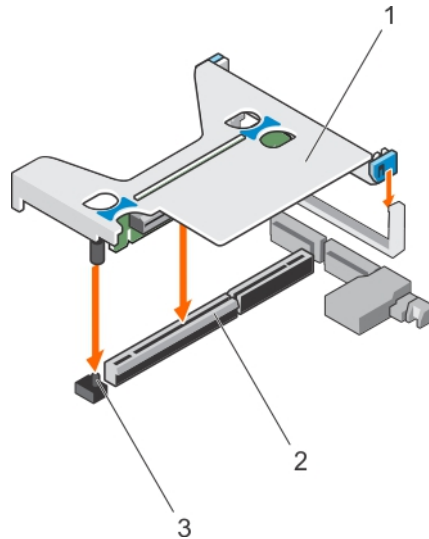

**Figure 40. Installing the expansion card riser 1**

- a. expansion card riser 1
- b. connector
- c. riser guide pin

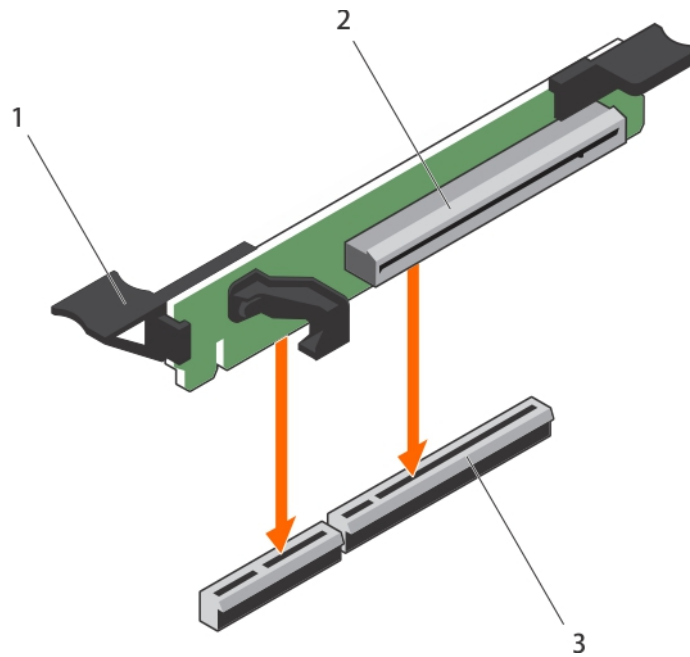

**Figure 41. Installing the expansion card riser 3**

- a. expansion card release latch
- b. expansion card riser 3
- c. connector

**Next steps**

1. Follow the procedure listed in the After working inside your system section.
2. Install any device drivers needed for the card as described in the documentation for the card.

**Related references**

[Safety instructions](#) on page 59

## Related tasks

[Before working inside your system](#) on page 60

[After working inside your system](#) on page 60

# SD vFlash media card (optional)

An SD vFlash card is a Secure Digital (SD) card that plugs into the SD vFlash card slot in the iDRAC port card. It provides persistent on-demand local storage and a custom deployment environment that enables automation of server configuration, scripts, and imaging. It emulates USB device(s). For more information, see the Integrated Dell Remote Access Controller User's Guide at [Dell.com/idracmanuals](http://Dell.com/idracmanuals).

## Replacing an SD vFlash card

### Prerequisites

**NOTE:** This procedure applies only to the eight hard drive system.

### Steps

1. Locate the vFlash media slot on the system.
2. To remove the installed SD vFlash card, push inward on the card to release it and pull the card from the card slot.

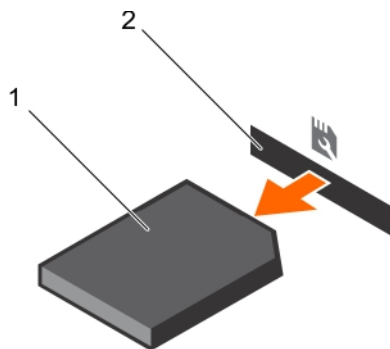

**Figure 42. Removing the SD vFlash card**

- a. SD vFlash card
- b. SD vFlash card slot

3. To install the SD vFlash card, with the label side facing up, insert the contact-pin end of the SD card into the card slot on the module.

**NOTE:** The slot is keyed to ensure correct insertion of the card.

4. Press inward on the card to lock it into the slot.

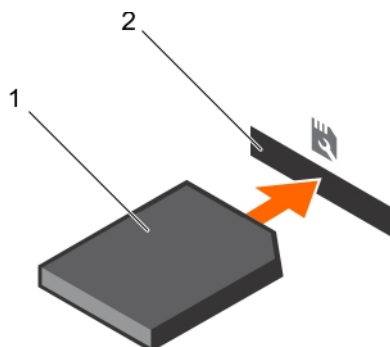

**Figure 43. Installing the SD vFlash card**

- a. SD vFlash card

- b. SD vFlash card slot

## Integrated storage controller card

Your system includes a dedicated expansion card slot on the system board for an integrated controller card. The integrated storage controller card provides the integrated storage subsystem for the internal hard drives in your system. The controller supports SAS and SATA hard drives and also enables you to set up the hard drives in RAID configurations. The RAID configurations depend on the version of the storage controller included with your system.

## Removing the integrated storage controller card

### Prerequisites

 **CAUTION:** Many repairs may only be done by a certified service technician. You should only perform troubleshooting and simple repairs as authorized in your product documentation, or as directed by the online or telephone service and support team. Damage due to servicing that is not authorized by Dell is not covered by your warranty. Read and follow the safety instructions that are shipped with your product.

1. Follow the safety guidelines listed in the Safety instructions section.
2. Follow the procedure listed in the Before working inside your system section.
3. Remove the cooling shroud.
4. Remove the expansion card riser 1.
5. Keep the Phillips #2 screwdriver ready.

### Steps

1. Loosen the screws that secure the integrated storage controller cable to the integrated storage controller card connector on the system board.
2. Lift the integrated storage controller cable away from the integrated storage controller.
3. Lift one end of the card and angle it to disengage the card from the integrated storage controller card holder on the system board.
4. Lift the card out of the system.

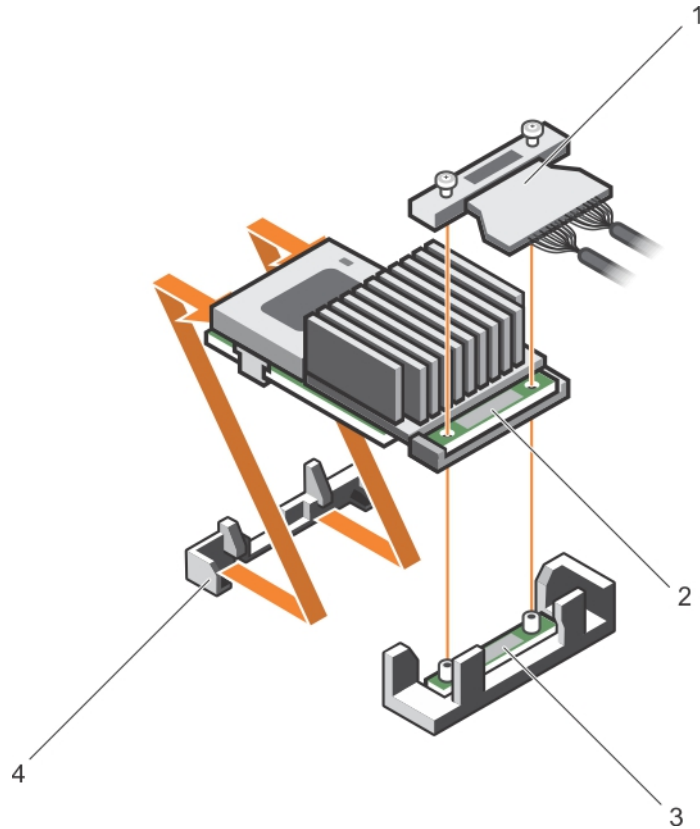

**Figure 44. Removing the integrated storage controller card**

- |   |  |
|---|--|
| 1. integrated storage controller cable                              | 2. integrated storage controller card        |
| 3. integrated storage controller card connector on the system board | 4. integrated storage controller card holder |

### Next steps

1. Install the expansion card riser 1.
2. Install the cooling shroud.
3. Follow the procedure listed in the After working inside your system section.

### Related references

[Safety instructions](#) on page 59

### Related tasks

[Before working inside your system](#) on page 60

[After working inside your system](#) on page 60

## Installing the integrated storage controller card

### Prerequisites

**CAUTION:** Many repairs may only be done by a certified service technician. You should only perform troubleshooting and simple repairs as authorized in your product documentation, or as directed by the online or telephone service and support team. Damage due to servicing that is not authorized by Dell is not covered by your warranty. Read and follow the safety instructions that are shipped with your product.

1. Follow the safety guidelines listed in the Safety instructions section.
2. Follow the procedure listed in the Before working inside your system section.

3. Remove the cooling shroud.
4. Remove the expansion card riser 1.
5. Keep the Phillips #2 screwdriver ready.

**Steps**

1. Align the end of the integrated storage controller card with the controller card connector on the system board.
2. Lower the connector side of the integrated storage controller card into the integrated storage controller card connector on the system board.

**NOTE:** Ensure that the tabs on the system board align with the screw holes on the integrated storage controller card.

3. Align the screws on the integrated storage controller card cable with the screw holes on the connector.
4. Tighten the screws to secure the integrated storage controller card cable with the integrated storage controller card connector on the system board.

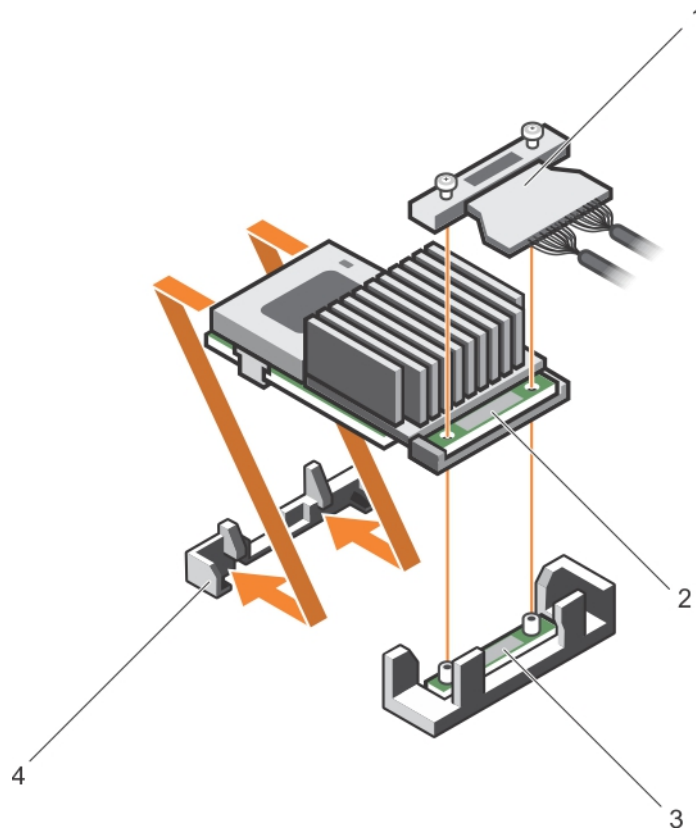

**Figure 45. Installing the integrated storage controller card**

- |   |  |
|---|--|
| 1. integrated storage controller cable                              | 2. integrated storage controller card        |
| 3. integrated storage controller card connector on the system board | 4. integrated storage controller card holder |

**Next steps**

1. Install the expansion card riser 1.
2. Install the cooling shroud.
3. Follow the procedure listed in the After working inside your system section.

**Related references**

[Safety instructions](#) on page 59

## Related tasks

[Before working inside your system](#) on page 60

[After working inside your system](#) on page 60

# Network daughter card

## Removing the network daughter card

### Prerequisites

 **CAUTION:** Many repairs may only be done by a certified service technician. You should only perform troubleshooting and simple repairs as authorized in your product documentation, or as directed by the online or telephone service and support team. Damage due to servicing that is not authorized by Dell is not covered by your warranty. Read and follow the safety instructions that are shipped with your product.

1. Follow the safety guidelines listed in the Safety instructions section.
2. Follow the procedure listed in the Before working inside your system section.
3. Keep the Phillips #2 screwdriver handy.

### Steps

1. Remove the expansion card riser 3.
2. Using a Phillips #2 screwdriver, loosen the two captive screws that secure the Network Daughter Card (NDC) to the system board.
3. Hold the NDC by the edges on either side of the touch points and lift to remove it from the connector on the system board.
4. Slide the NDC away from the back of the system until the Ethernet connectors are clear of the slot in the back panel.
5. Lift the NDC out of the system.

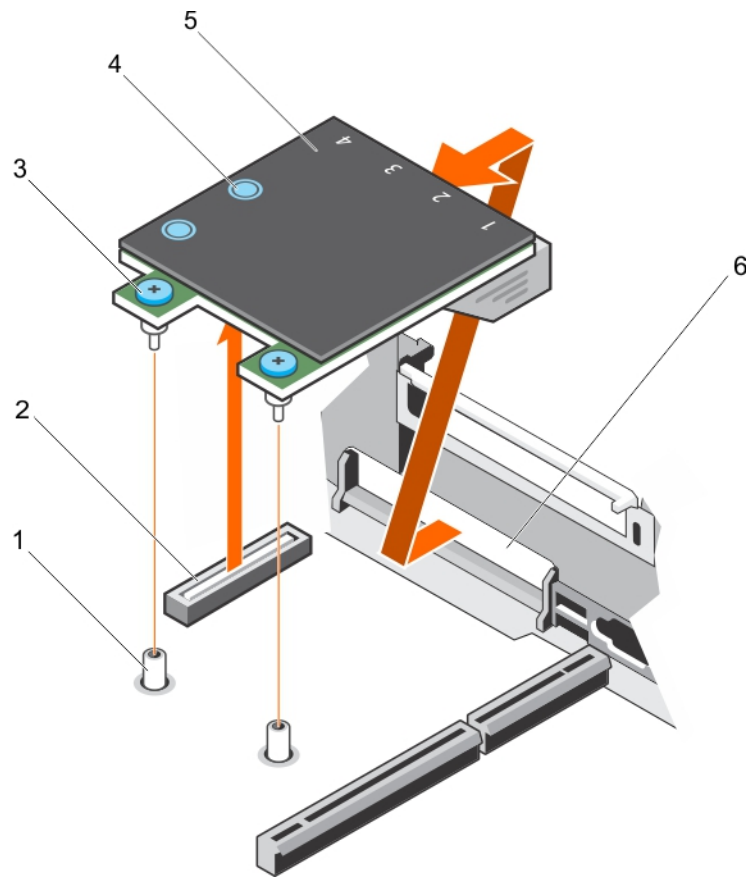

**Figure 46. Removing the NDC**

- |   |   |
|---|---|
| <ul style="list-style-type: none"> <li>1. captive screw socket (2)</li> <li>3. captive screw (2)</li> <li>5. NDC</li> </ul> | <ul style="list-style-type: none"> <li>2. connector on the system board</li> <li>4. touch point (2)</li> <li>6. back panel slots for Ethernet connectors</li> </ul> |
|---|---|

### Related references

[Safety instructions](#) on page 59

### Related tasks

[Before working inside your system](#) on page 60

## Installing the network daughter card

### Prerequisites

**CAUTION:** Many repairs may only be done by a certified service technician. You should only perform troubleshooting and simple repairs as authorized in your product documentation, or as directed by the online or telephone service and support team. Damage due to servicing that is not authorized by Dell is not covered by your warranty. Read and follow the safety instructions that are shipped with your product.

**CAUTION:** If the GPU card is installed, you cannot install the 10 GbE Network Daughter Card (NDC).

1. Follow the safety guidelines listed in the Safety instructions section.
2. Follow the procedure listed in the Before working inside your system section.
3. Keep the Philips #1 screwdriver handy.

**NOTE:** If the system has three PCIe cards, ensure that you install the PCIe cooling shroud in your system.

## Steps

1. Orient the NDC so that the Ethernet connectors fit through the slot in the back panel.
2. Align the captive screws at the back-end of the card with the screw holes on the system board.
3. To ensure that the connector on the card is in contact with the connector on the system board, press the touch point on the card.
4. Tighten the two captive screws to secure the NDC to the system board.
5. Install the expansion card riser 3.

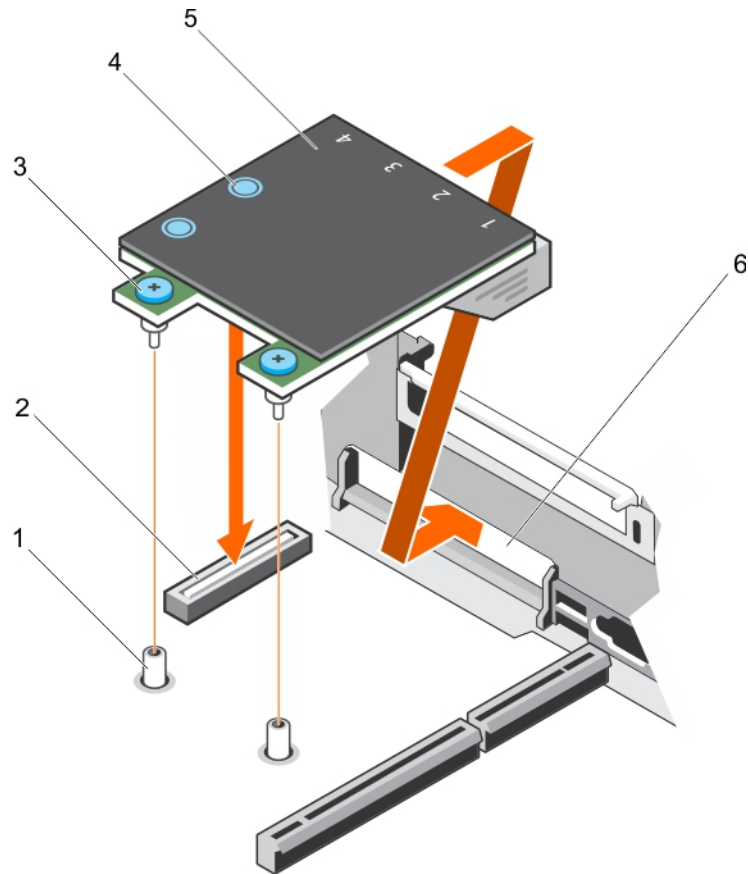

**Figure 47. Installing the NDC**

- |                             |   |
|-----------------------------|---|
| 1. captive screw socket (2) | 2. connector on the system board            |
| 3. captive screw (2)        | 4. touch point (2)                          |
| 5. NDC                      | 6. back panel slots for Ethernet connectors |

## Next steps

Follow the procedure listed in the After working inside your system section.

## Related references

[Safety instructions](#) on page 59

## Related tasks

[Before working inside your system](#) on page 60

[After working inside your system](#) on page 60

# Processors and heat sinks

Use the following procedure when:

- Removing and installing a heat sink
- Installing an additional processor
- Replacing a processor

 **NOTE:** To ensure proper system cooling, you must install a processor blank in any empty processor socket.

## Removing a processor

### Prerequisites

 **CAUTION:** Many repairs may only be done by a certified service technician. You should only perform troubleshooting and simple repairs as authorized in your product documentation, or as directed by the online or telephone service and support team. Damage due to servicing that is not authorized by Dell is not covered by your warranty. Read and follow the safety instructions that are shipped with your product.

 **NOTE:** This is a Field Replaceable Unit (FRU). Removal and installation procedures should be performed only by Dell certified service technicians.

 **NOTE:** To ensure proper system cooling, you must install a processor blank in any empty processor socket.



1. Follow the safety guidelines listed in the Safety instructions section.
2. Follow the procedure listed in the Before working inside your system section.
3. Keep the Phillips #2 screwdriver ready.
4. If installed, remove the full-length PCIe card(s).
5. Remove the cooling shroud.
6. Remove the heat sink.
7. If you are upgrading your system, download the latest system BIOS version from [Dell.com/support](https://Dell.com/support) and follow the instructions included in the compressed download file to install the update on your system.

 **NOTE:** You can update the system BIOS by using the Dell Lifecycle Controller.

 **CAUTION:** The processor is held in its socket under strong pressure. Be aware that the release lever can spring up suddenly if not firmly grasped.

 **WARNING:** The processor is hot to touch for some time after the system has been powered down. Allow the processor to cool before removing it.

### Steps

1. Release the *open first* socket lever near the unlock icon  by pushing the lever down and out from under the tab.
2. Release the *close first* socket release lever near the lock icon  by pushing the lever down and out from under the tab. Lift the lever 90 degrees upward.
3. Lower the *open first* socket-release lever to lift the processor shield.
4. Hold the tab on the processor shield and lift the processor shield until the *open first* socket-release lever lifts up.

 **CAUTION:** The socket pins are fragile and can be permanently damaged. Be careful not to bend the pins in the socket when removing the processor out of the socket.

5. Lift the processor out of the socket and leave the *open first* socket-release lever up.

 **NOTE:** If you are permanently removing the processor, you must install a socket protective cap in the vacant socket to protect the socket pins and keep the socket free of dust.

 **NOTE:** After removing the processor, place it in an anti-static container for reuse, return, or temporary storage. Do not touch the bottom of the processor. Touch only the side edges of the processor.

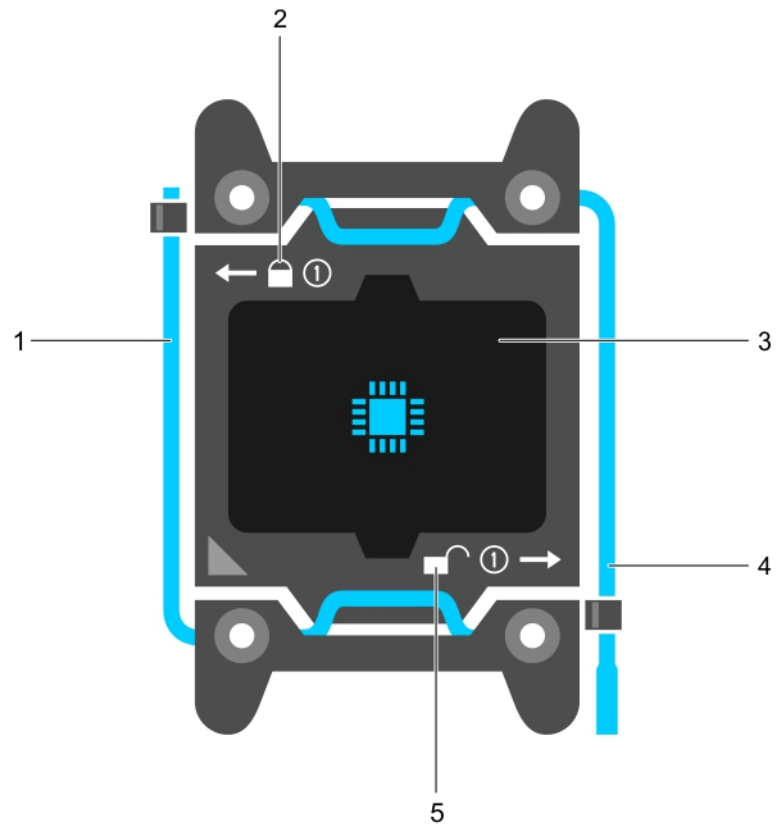

**Figure 48. Processor shield**

- 1. *close first* socket release lever
- 2. lock icon
- 3. processor
- 4. *open first* socket release lever
- 5. unlock icon

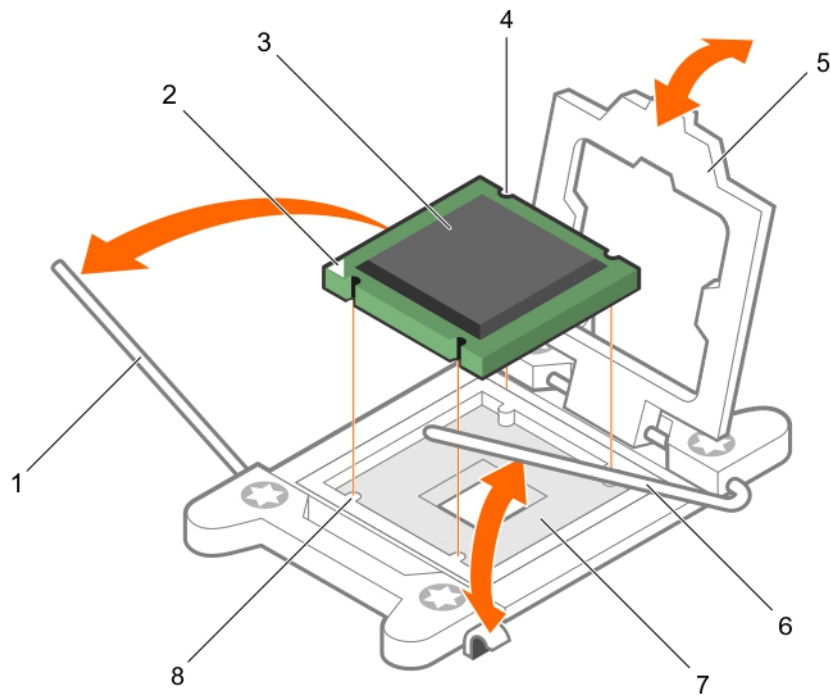

**Figure 49. Removing and installing a processor**

- |  |   |
|--|---|
| 1. <i>close first</i> socket-release lever | 2. pin-1 indicator of processor           |
| 3. processor                               | 4. slot (4)                               |
| 5. processor shield                        | 6. <i>open first</i> socket-release lever |
| 7. socket                                  | 8. socket keys (4)                        |

### Next steps

1. Replace the processor(s).
2. Install the heat sink.
3. Reinstall the cooling shroud.
4. Follow the procedure listed in the After working inside your system section.

### Related references

[Safety instructions](#) on page 59

### Related tasks

[Before working inside your system](#) on page 60

[After working inside your system](#) on page 60

## Installing a processor

### Prerequisites

**CAUTION:** Many repairs may only be done by a certified service technician. You should only perform troubleshooting and simple repairs as authorized in your product documentation, or as directed by the online or telephone service and support team. Damage due to servicing that is not authorized by Dell is not covered by your warranty. Read and follow the safety instructions that are shipped with your product.

 **NOTE:** This is a Field Replaceable Unit (FRU). Removal and installation procedures should be performed only by Dell certified service technicians.

1. Follow the safety guidelines listed in the Safety instructions section.
2. Follow the procedure listed in the Before working inside your system section.
3. Keep the Phillips #2 screwdriver ready.
4. If you are upgrading your system, download the latest system BIOS version from **Dell.com/support** and follow the instructions included in the compressed download file to install the update on your system.

 **NOTE:** You can also update the system BIOS by using the Dell Lifecycle Controller.

5. If installed, remove the full-length PCIe card.
6. Remove the cooling shroud.

 **NOTE:** If applicable, close the expansion card latch on the cooling shroud to release the full length card.

 **NOTE:** The heat sink and processor are too hot to touch for some time after the system has been powered down. Allow the heat sink and processor to cool down before handling them.



 **CAUTION:** Never remove the heat sink from a processor unless you intend to remove the processor. The heat sink is necessary to maintain proper thermal conditions.

 **NOTE:** If you are installing a single processor, it must be installed in socket CPU1.

## Steps

1. Unpack the new processor.

 **NOTE:** If the processor has previously been used in a system, remove any remaining thermal grease from the processor by using a lint-free cloth.

2. Locate the processor socket.
3. If applicable, remove the socket protective cap.
4. Release the *open first* socket-release lever near the unlock icon  by pushing the lever down and out from under the tab.
5. Similarly, release the *close first* socket-release lever near the lock icon  by pushing the lever down and out from under the tab. Lift the lever 90 degrees upward.
6. Hold the tab near the lock symbol on the processor shield and lift it up and out of the way.

 **CAUTION:** Positioning the processor incorrectly can permanently damage the system board or the processor. Be careful not to bend the pins in the socket.

 **CAUTION:** While removing or reinstalling the processor, wipe your hands of any contaminants. Contaminants on the processor pins such as thermal grease or oil can damage the processor.

7. Align the processor with the socket keys.

 **CAUTION:** Do not use force to seat the processor. When the processor is positioned correctly, it engages easily into the socket.

8. Align the pin-1 indicator of the processor with the triangle on the socket .

 **CAUTION:** Do not use force to seat the processor. When the processor is positioned correctly, it engages easily into the socket.

9. Place the processor on the socket such that the slots on the processor align with the socket keys.
10. Close the processor shield.

11. Lower the *close first* socket-release lever near the lock icon  and push it under the tab to lock it.

12. Similarly, lower the *open first* socket-release lever near the unlock icon  and push it under the tab to lock it.

## Next steps

**NOTE:** Ensure that you install the heat sink after you install the processor. The heat sink is necessary to maintain proper thermal conditions.

1. Install the heat sink.
2. While booting, press F2 to enter System Setup and verify that the processor information matches the new system configuration.
3. Run the system diagnostics to verify that the new processor operates correctly.

## Power supply units

Your system supports one of the following:

- Two 495 W, 750 W, or 1100 W AC power supply units (PSUs)
- Two 1100 W DC PSUs
- Two 750 W mixed mode PSUs

**CAUTION:** For AC PSUs, use only PSUs with the Extended Power Performance (EPP) label on the back. Mixing PSUs from previous generations of systems can result in a PSU mismatch condition or failure to turn on.

**NOTE:** Titanium PSU is nominally rated for 200 V AC to 240 V AC input only.

**NOTE:** When two identical PSUs are installed, power supply redundancy (1+1 – with redundancy or 2+0 – without redundancy) is configured in system BIOS. In redundant mode, power is supplied to the system equally from both PSUs when Hot Spare is disabled. When Hot Spare is enabled, one of the PSUs will be put into standby when system utilization is low in order to maximize efficiency.

**NOTE:** If two PSUs are used, they must be of the same maximum output power.

## Hot spare feature

Your system supports the hot spare feature that significantly reduces the power overhead associated with power supply redundancy.

When the hot spare feature is enabled, one of the redundant PSUs is switched to the sleep state. The active PSU supports 100 percent of the load, thus operating at higher efficiency. The PSU in the sleep state monitors output voltage of the active PSU. If the output voltage of the active PSU drops, the PSU in the sleep state returns to an active output state.

If having both PSUs active is more efficient than having one PSU in the sleep state, the active PSU can also activate the sleeping PSU.

The default PSU settings are as follows:

- If the load on the active PSU is more than 50 percent, then the redundant PSU is switched to the active state.
- If the load on the active PSU falls below 20 percent, then the redundant PSU is switched to the sleep state.

You can configure the hot spare feature by using the iDRAC settings. For more information about iDRAC settings, see the *Integrated Dell Remote Access Controller User's Guide* available at [Dell.com/idracmanuals](http://Dell.com/idracmanuals).

## Removing the power supply unit blank

### Steps

If you are installing a second power supply unit (PSU), remove the PSU blank in the bay by pulling the blank outward.

**CAUTION:** To ensure proper system cooling, the power supply blank must be installed in the second PSU bay in a non-redundant configuration. Remove the PSU blank only if you are installing a second PSU.

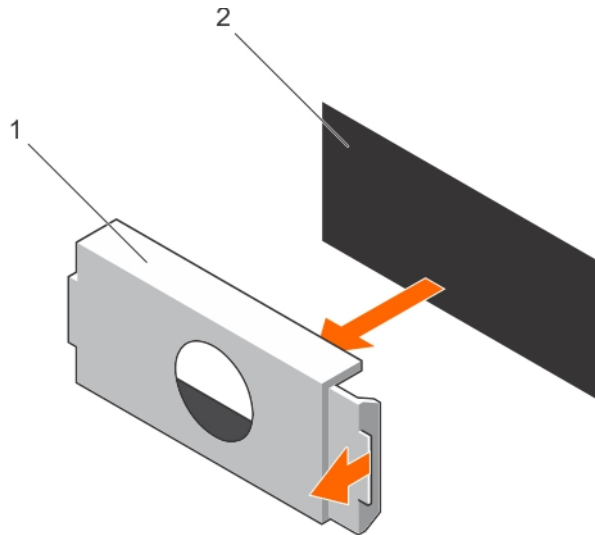

**Figure 50. Removing the PSU blank**

- a. PSU blank
- b. PSU bay

## Installing the power supply unit blank

Install the power supply unit (PSU) blank only in the second PSU bay.

### Steps

Align the PSU blank with the PSU bay and push it into the chassis until it clicks into place.

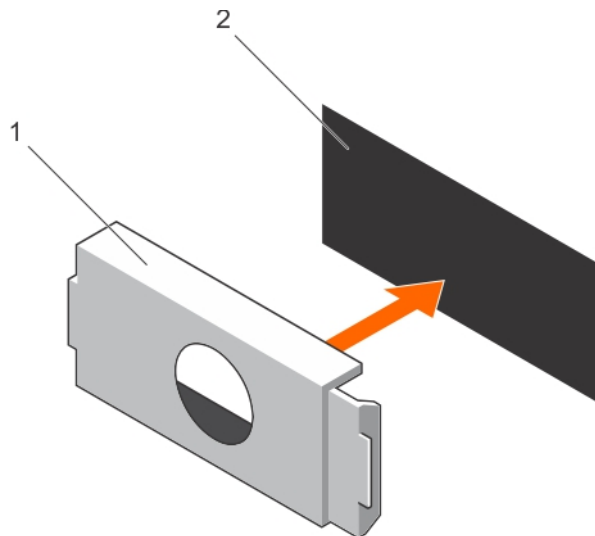

**Figure 51. Installing the PSU blank**

- a. PSU blank
- b. PSU bay

## Removing an AC power supply unit

### Prerequisites

**CAUTION:** Many repairs may only be done by a certified service technician. You should only perform troubleshooting and simple repairs as authorized in your product documentation, or as directed by the online or

telephone service and support team. Damage due to servicing that is not authorized by Dell is not covered by your warranty. Read and follow the safety instructions that are shipped with your product.

**CAUTION:** The system needs one power supply for normal operation. On power-redundant systems, remove and replace only one power supply at a time in a system that is powered on.

**NOTE:** You may have to unlatch and lift the optional cable management arm if it interferes with the power supply unit (PSU) removal. For information about the cable management arm, see the system's rack documentation.

### Steps

1. Disconnect the power cable from the power source and from the PSU you intend to remove, and then remove the cables from the strap.
2. Press the release latch and slide the PSU out of the chassis by using the PSU handle.

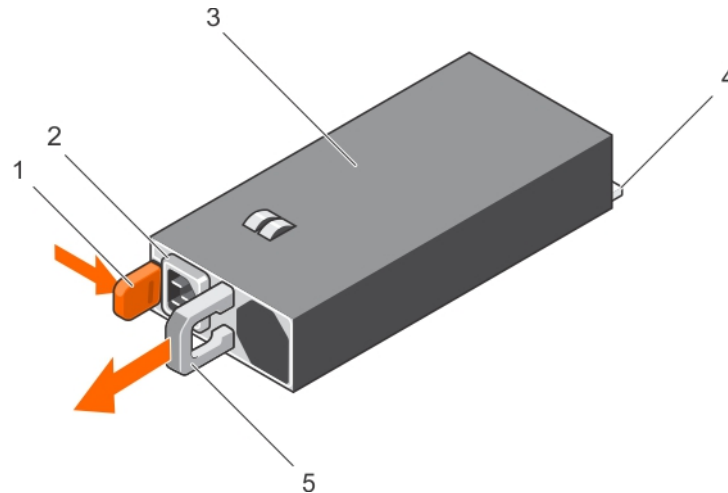

**Figure 52. Removing an AC PSU**

- |                  |                        |
|------------------|------------------------|
| 1. release latch | 2. PSU cable connector |
| 3. PSU           | 4. power connector     |
| 5. PSU handle    |                        |

## Installing an AC power supply unit

### Prerequisites

**CAUTION:** Many repairs may only be done by a certified service technician. You should only perform troubleshooting and simple repairs as authorized in your product documentation, or as directed by the online or telephone service and support team. Damage due to servicing that is not authorized by Dell is not covered by your warranty. Read and follow the safety instructions that are shipped with your product.

**NOTE:** The maximum output power (shown in watts) is listed on the PSU label.

1. Follow the safety guidelines listed in the Safety instructions section.
2. For systems that support redundant power supply units (PSUs), ensure that both the PSUs are of the same type and have the same maximum output power
3. If installed, remove the PSU blank.

### Steps

1. Slide the new PSU into the chassis until the PSU is fully seated and the release latch snaps into place.

**NOTE:** If you unlatched the cable management arm, relatch it. For information about the cable management arm, see the rack documentation of your system.

2. Connect the power cable to the PSU and plug the cable into a power outlet.

**CAUTION:** When connecting the power cable, secure the cable with the strap.

**NOTE:** When installing, hot swapping, or hot-adding a new PSU, wait for 15 seconds for the system to recognize the PSU and determine its status. The power supply redundancy may not occur until discovery is complete. Wait until the new PSU is discovered and enabled before you remove the other PSU. The PSU status indicator turns green to signify that the PSU is functioning properly.

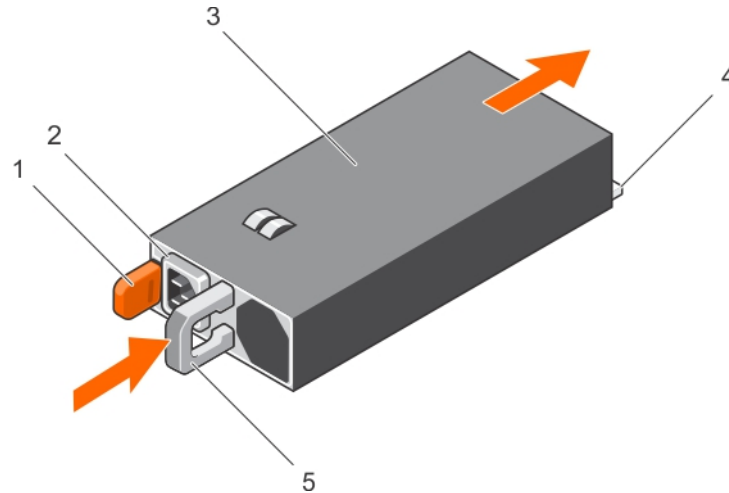

**Figure 53. Installing an AC PSU**

- |                  |                        |
|------------------|------------------------|
| 1. release latch | 2. PSU cable connector |
| 3. PSU           | 4. power connector     |
| 5. PSU handle    |                        |

### Related references

[Safety instructions](#) on page 59

## Wiring instructions for a DC power supply unit

Your system supports up to two  $-(48-60)$  V DC power supply units (PSUs).

**NOTE:** For equipment using  $-(48-60)$  V DC power supply units (PSUs), a qualified electrician must perform all connections to DC power and to safety grounds. Do not attempt connecting to DC power or installing grounds yourself. All electrical wiring must comply with applicable local or national codes and practices. Damage due to servicing that is not authorized by Dell is not covered by your warranty. Read and follow all safety instructions that came with the product.

**CAUTION:** Wire the unit with copper only, unless otherwise specified, use only 10 American Wire Gauge (AWG) wire rated minimum 90 °C for source and return. Protect the  $-(48-60)$  V DC (1 wire) with a branch circuit over-current protection rated 50 A for DC with a high interrupt current rating.

**CAUTION:** Connect the equipment to a  $-(48-60)$  V DC supply source that is electrically isolated from the AC source (reliably grounded  $-(48-60)$  V DC SELV source). Ensure that the  $-(48-60)$  V DC source is efficiently secured to earth (ground).

**NOTE:** A readily accessible disconnect device that is suitably approved and rated shall be incorporated in the field wiring.

### Input requirements

- Supply voltage:  $-(48-60)$  V DC
- Current consumption: 32 A (maximum)

## Kit contents

- Dell part number 6RYJ9 terminal block or equivalent (1)
- #6-32 nut equipped with lock washer (1)

## Required tools

Wire-stripper pliers capable of removing insulation from size 10 AWG solid or stranded, insulated copper wire

**NOTE:** Use alpha wire part number 3080 or equivalent (65/30 stranding)

## Required wires

- One UL 10 AWG, 2 m maximum (stranded) black wire [-(48-60) V DC]
- One UL 10 AWG, 2 m maximum (stranded) red wire (V DC return)
- One UL 10 AWG, 2 m maximum green/yellow, green with a yellow stripe, stranded wire (safety ground)

## Removing a DC power supply unit

### Prerequisites

**NOTE:** For equipment using -(48-60) V DC power supply units (PSUs), a qualified electrician must perform all connections to DC power and to safety grounds. Do not attempt connecting to DC power or installing grounds yourself. All electrical wiring must comply with applicable local or national codes and practices. Damage due to servicing that is not authorized by Dell is not covered by your warranty. Read and follow all safety instructions that came with the product.

**CAUTION:** The system needs one power supply for normal operation. On power-redundant systems, remove and replace only one power supply at a time in a system that is powered on.

**NOTE:** You may have to unlatch and lift the optional cable management arm if it interferes with power supply removal. For information about the cable management arm, see the rack documentation of your system.

### Steps

1. Disconnect the power wires from the power source and the connector from the PSU you intend to remove.
2. Disconnect the safety ground wire.
3. Press the release latch and slide the PSU out of the chassis by using the PSU handle.

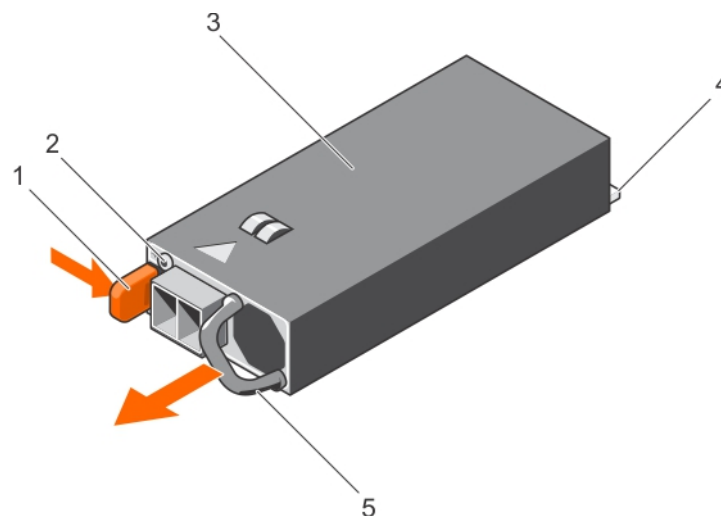

**Figure 54. Removing a DC PSU**

1. release latch
2. power supply status indicator

3. PSU
5. PSU handle

4. power connector

## Installing a DC power supply unit

### Prerequisites

**NOTE:** For equipment using  $-(48-60)$  V DC power supply units (PSUs), a qualified electrician must perform all connections to DC power and to safety grounds. Do not attempt connecting to DC power or installing grounds yourself. All electrical wiring must comply with applicable local or national codes and practices. Damage due to servicing that is not authorized by Dell is not covered by your warranty. Read and follow all safety instructions that came with the product.

1. Follow the safety guidelines listed in the Safety instructions section.
2. Follow the procedure listed in the Before working inside your system section.
3. If installed, remove the PSU blank.
4. Verify that both the PSUs are of the same type and have the same maximum output power.

**NOTE:** The maximum output power (shown in watts) is listed on the PSU label.

### Steps

1. Slide the PSU into the chassis until the PSU is fully seated and the release latch snaps into place.

**NOTE:** If you have unlatched the cable management arm, relatch it. For information about the cable management arm, see the system's rack documentation.

2. Connect the safety ground wire.
3. Install the DC power connector in the PSU.

**CAUTION:** When connecting the power wires, ensure that you secure the wires with the strap to the PSU handle.

4. Connect the wires to a DC power source.

**NOTE:** When installing, hot-swapping, or hot-adding a new PSU, wait for 15 seconds for the system to recognize the PSU and determine its status. The PSU status indicator turns green to signify that the PSU is functioning properly.

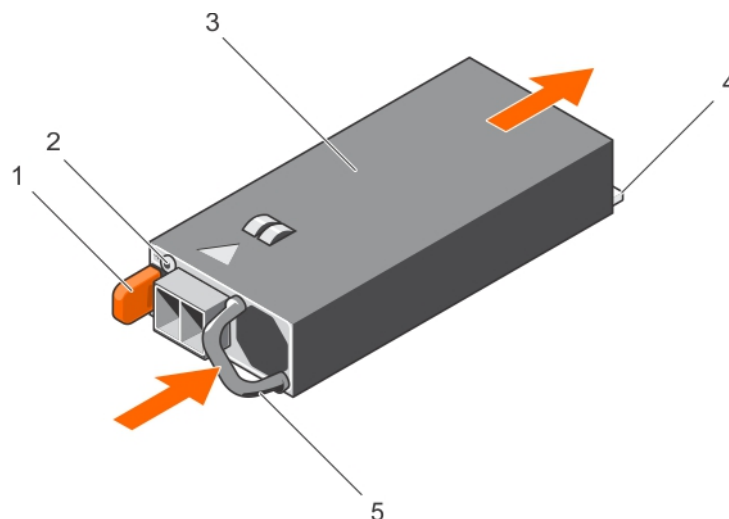

**Figure 55. Installing a DC PSU**

1. release latch
2. power supply status indicator
3. PSU
4. power connector
5. PSU handle

## Next steps

- Follow the procedure listed in the After working inside your system section.

## Related references

[Safety instructions](#) on page 59

## Related tasks

[Before working inside your system](#) on page 60

[After working inside your system](#) on page 60

# System battery

The system board battery is used for low-level system functions like powering the real-time clock and storing the computer's BIOS settings.

## Replacing the system battery

### Prerequisites

**NOTE:** There is a danger of a new battery exploding if it is incorrectly installed. Replace the battery only with the same or equivalent type recommended by the manufacturer. For more information, see the safety information that shipped with your system.

**CAUTION:** Many repairs may only be done by a certified service technician. You should only perform troubleshooting and simple repairs as authorized in your product documentation, or as directed by the online or telephone service and support team. Damage due to servicing that is not authorized by Dell is not covered by your warranty. Read and follow the safety instructions that are shipped with your product.

1. Follow the safety guidelines listed in the Safety instructions section.
2. Follow the procedure listed in the Before working inside your system section.
3. Remove the cooling shroud.

### Steps

1. Locate the battery socket. For more information, see the System board jumpers and connectors section.

**CAUTION:** To avoid damage to the battery connector, you must firmly support the connector while installing or removing a battery.

2. Place your finger between the securing tabs at the negative side of the battery connector and lift the battery out of the socket.

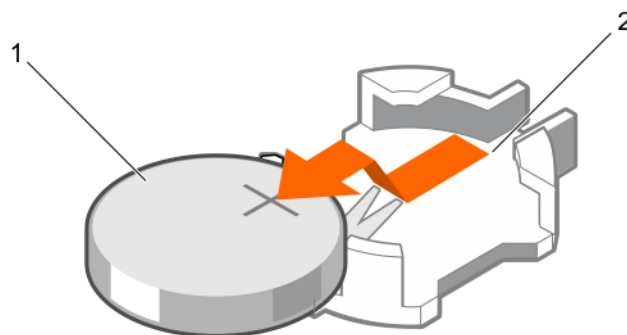

**Figure 56. Removing the system battery**

- a. system battery

- b. system battery slot
- 3. To install a new system battery, hold the battery with the "+" facing up and slide it under the securing tabs.
- 4. Press the battery into the connector until it snaps into place.

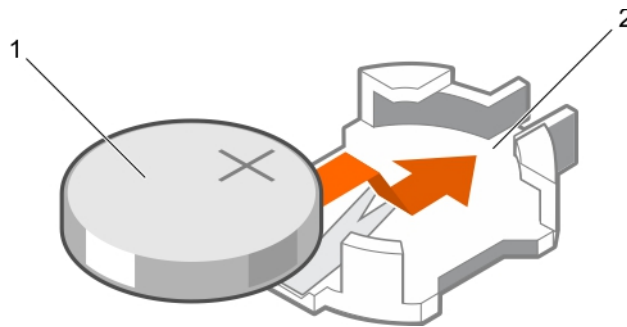

**Figure 57. Installing the system battery**

- a. system battery
- b. system battery slot

### Next steps

1. Install the cooling shroud.
2. Follow the procedure listed in the After working inside your system section.
3. While booting, press F2 to enter System Setup and ensure the battery is operating properly.
4. Enter the correct time and date in the System Setup **Time** and **Date** fields.
5. Exit System Setup.

### Related references

[Safety instructions](#) on page 59

[Jumpers and connectors](#) on page 130

### Related tasks

[Before working inside your system](#) on page 60

[After working inside your system](#) on page 60

## Hard drive backplane

Depending on the configuration, your system supports one of the following:

**Eight hard drive system supports** 2.5-inch (x4) SAS/SATA backplane

## Removing the hard drive backplane

### Prerequisites

- ⚠ **CAUTION:** Many repairs may only be done by a certified service technician. You should only perform troubleshooting and simple repairs as authorized in your product documentation, or as directed by the online or telephone service and support team. Damage due to servicing that is not authorized by Dell is not covered by your warranty. Read and follow the safety instructions that are shipped with your product.
- ⚠ **CAUTION:** To prevent damage to the hard drives and hard drive backplane, remove the hard drives from the system before removing the hard drive backplane.
- ⚠ **CAUTION:** Note the number of each hard drive and temporarily label them before removal so that you can replace them in the same locations.

1. Follow the safety guidelines listed in the Safety instructions section.
2. Follow the procedure listed in the Before working inside your system section.
3. Remove all hard drives.

**Steps**

1. Disconnect the SAS/SATA/SSD data cables and power cable from the backplane.
2. If applicable, disconnect the power and data cable from the optical drive.
3. Push the backplane blue release tabs in the direction of the arrows and lift the backplane upwards.
4. Pull the backplane away from the system until the securing slots on the backplane are free from the tabs on the chassis.

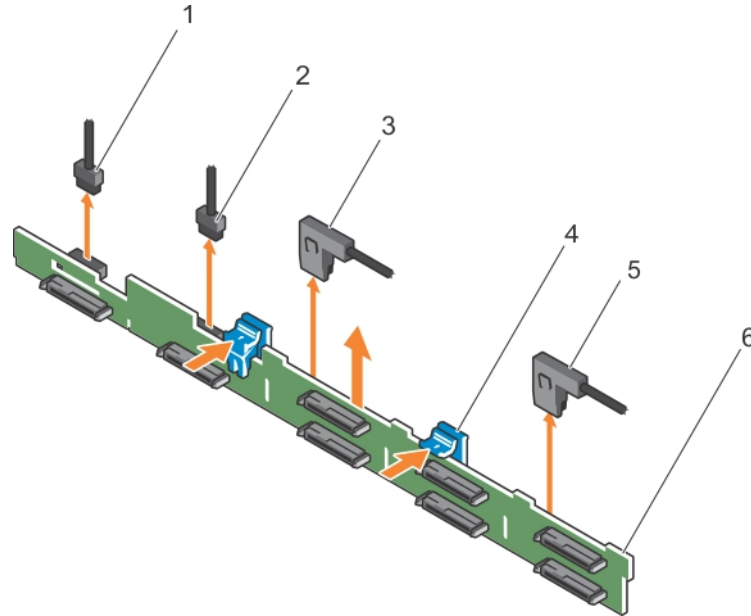

**Figure 58. Removing the 2.5-inch (x8) hard drive backplane**

- |                           |                           |
|---------------------------|---------------------------|
| 1. backplane signal cable | 2. backplane signal cable |
| 3. SAS A cable            | 4. release tabs (2)       |
| 5. SAS B cable            | 6. backplane              |

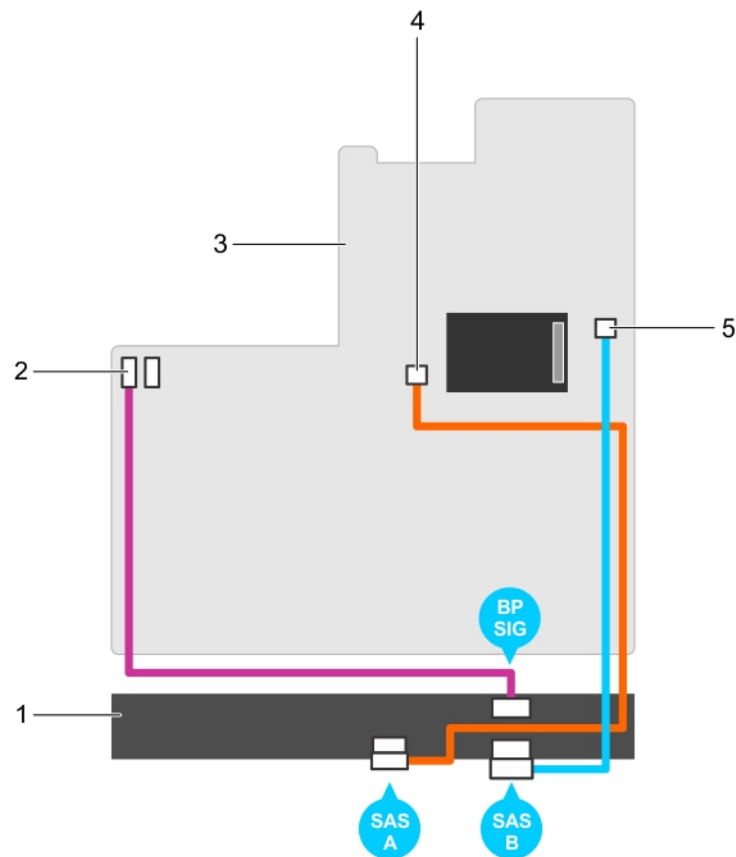

**Figure 59. Cabling diagram—2.5-inch (x8) hard drive systems**

- |                                    |                                     |
|------------------------------------|-------------------------------------|
| 1. SAS backplane                   | 2. signal connector on system board |
| 3. system board                    | 4. SAS A connector on system board  |
| 5. SAS B connector on system board |                                     |

### Related references

[Safety instructions](#) on page 59

### Related tasks

[Before working inside your system](#) on page 60

## Installing the hard drive backplane

### Prerequisites

1. Follow the safety guidelines listed in the Safety instructions section.
2. Follow the procedure listed in the Before working inside your system section.

**CAUTION:** Many repairs may only be done by a certified service technician. You should only perform troubleshooting and simple repairs as authorized in your product documentation, or as directed by the online or

telephone service and support team. Damage due to servicing that is not authorized by Dell is not covered by your warranty. Read and follow the safety instructions that are shipped with your product.

### Steps

1. Use the hooks on the chassis as guides to align the hard drive backplane.
2. Lower the hard drive backplane until the release tabs snap into place.
3. Connect the SAS/SATA/SSD data, signal, and power cables to the backplane.

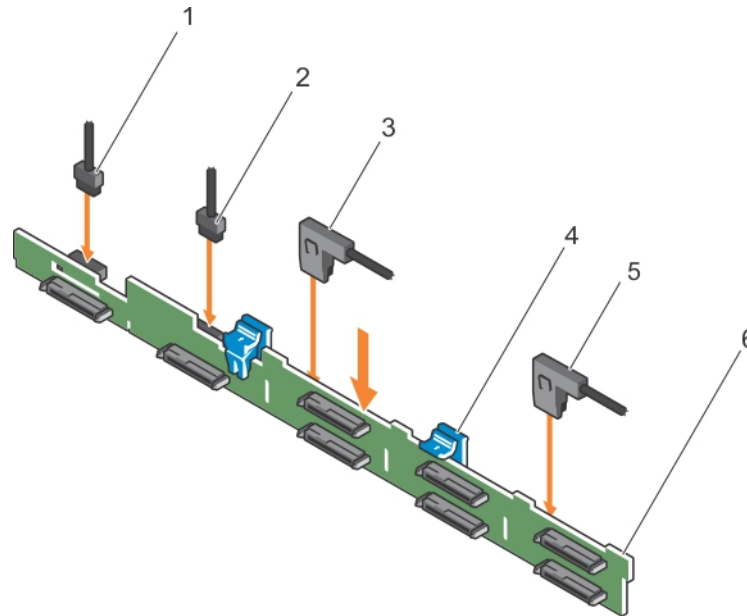

**Figure 60. Installing the 2.5-inch (x8) hard drive backplane**

- |                           |                           |
|---------------------------|---------------------------|
| 1. backplane signal cable | 2. backplane signal cable |
| 3. SAS A cable            | 4. release tabs (2)       |
| 5. SAS B cable            | 6. backplane              |

### Next steps

1. Install the hard drives in their original locations.
2. Follow the procedure listed in the After working inside your system section.

### Related references

[Safety instructions](#) on page 59

### Related tasks

[Before working inside your system](#) on page 60

[After working inside your system](#) on page 60

## Control panel assembly

### Removing the control panel board—eight hard drive system

#### Prerequisites

**CAUTION:** Many repairs may only be done by a certified service technician. You should only perform troubleshooting and simple repairs as authorized in your product documentation, or as directed by the online or

telephone service and support team. Damage due to servicing that is not authorized by Dell is not covered by your warranty. Read and follow the safety instructions that are shipped with your product.

**CAUTION:** The display module connector is a ZIF (zero insertion force) connector. Ensure that the locking tab on the connector is released before removal and insertion. The locking tab must be engaged after insertion.

1. Follow the safety guidelines listed in the Safety instructions section.
2. Follow the procedure listed in the Before working inside your system section.
3. Keep the Philips #2 screwdriver ready.

### Steps

1. Disconnect the control panel and display module cables from the control panel board.
2. Remove the two screws that secure the control panel board to the chassis.
3. Slide the control panel board toward the back and out of the system.

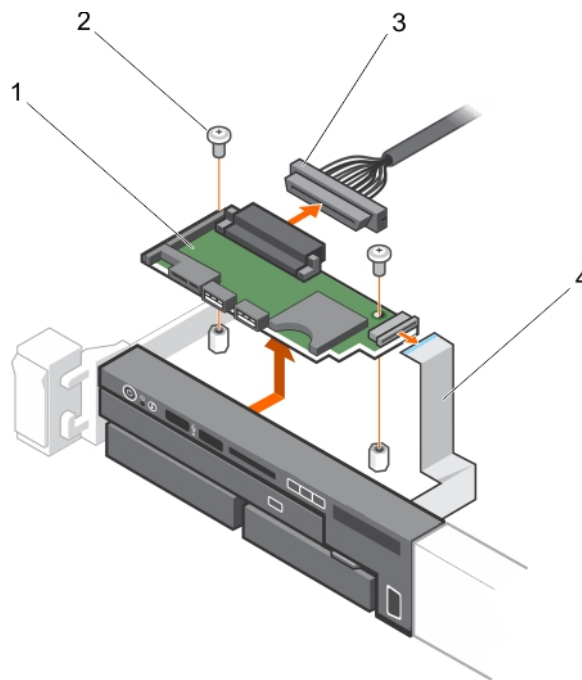

**Figure 61. Removing the control panel board**

- |                        |                         |
|------------------------|-------------------------|
| 1. control panel board | 2. screws (2)           |
| 3. control panel cable | 4. display module cable |

### Related references

[Safety instructions](#) on page 59

### Related tasks

[Before working inside your system](#) on page 60

[After working inside your system](#) on page 60

## Installing the control panel board—eight hard drive system

### Prerequisites

**CAUTION:** Many repairs may only be done by a certified service technician. You should only perform troubleshooting and simple repairs as authorized in your product documentation, or as directed by the online or

telephone service and support team. Damage due to servicing that is not authorized by Dell is not covered by your warranty. Read and follow the safety instructions that are shipped with your product.

1. Follow the safety guidelines listed in the Safety instructions section.
2. Keep the Philips #2 screwdriver ready.

### Steps

1. Align the screw holes on the control panel board with the standoffs on the chassis.
2. Replace the two screws that secure the control panel board to the chassis.

**CAUTION:** The display module connector is a ZIF (zero insertion force) connector. Ensure that the locking tab on the connector is released before removal and insertion. The locking tab must be engaged after insertion.

3. Connect control panel and display module cables to the control panel board.
4. If required, route the power and data cables along the chassis wall.

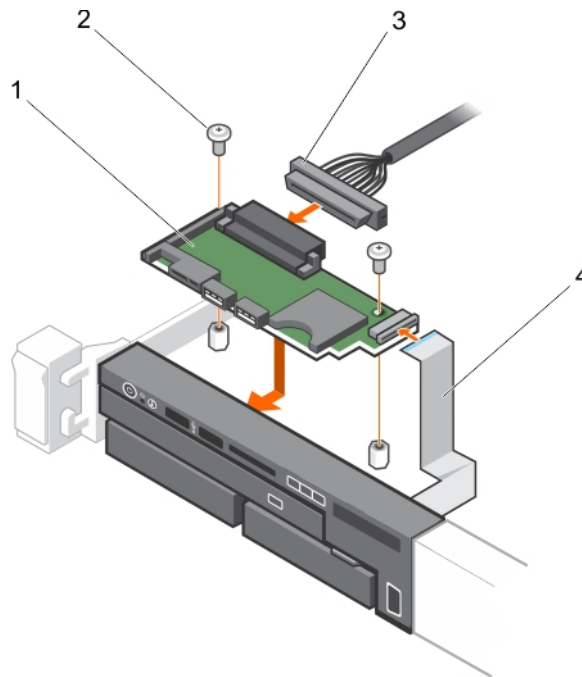

**Figure 62. Installing the control panel board**

- |                        |                         |
|------------------------|-------------------------|
| 1. control panel board | 2. screws (2)           |
| 3. control panel cable | 4. display module cable |

### Next steps

Follow the procedure listed in the After working inside your system section.

### Related tasks

[After working inside your system](#) on page 60

## VGA module

**NOTE:** Only the eight hard drive system has a VGA module on the front panel.

# Removing the VGA module

## Prerequisites

- CAUTION:** Many repairs may only be done by a certified service technician. You should only perform troubleshooting and simple repairs as authorized in your product documentation, or as directed by the online or telephone service and support team. Damage due to servicing that is not authorized by Dell is not covered by your warranty. Read and follow the safety instructions that are shipped with your product.
- CAUTION:** The display module connector is a ZIF (zero insertion force) connector. Ensure that the locking tab on the connector is released before removal and insertion. The locking tab must be engaged after insertion.

1. Follow the safety guidelines listed in the Safety instructions section.
2. Follow the procedure listed in the Before working inside your system section.
3. Keep the Philips #2 screwdriver ready.

## Steps

1. Disconnect the display module cable from the control panel board.
2. Remove the control panel.
3. Disconnect the VGA module cable from the VGA module.
4. Remove the screw that secures the VGA module to the chassis.
5. Slide the VGA module out of the chassis.

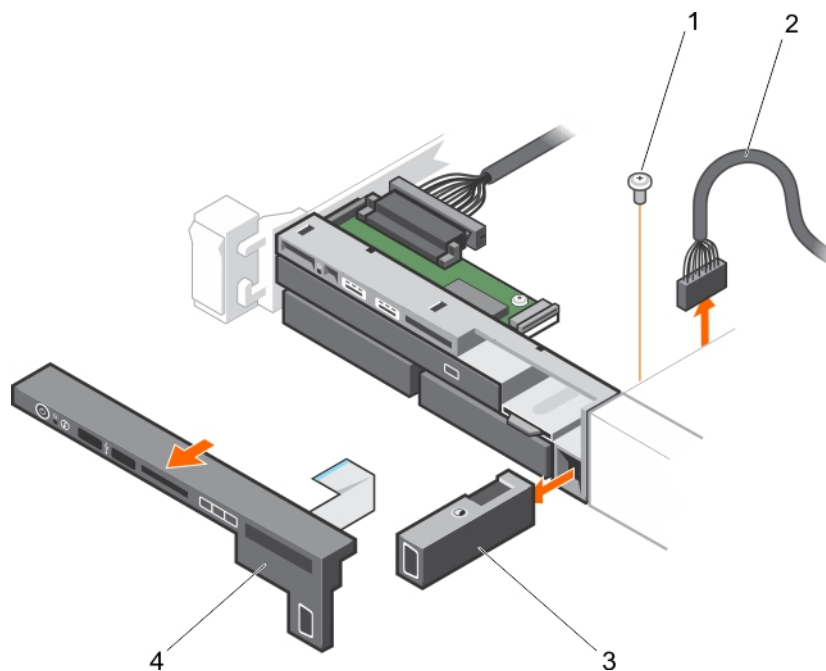

**Figure 63. Removing the VGA Module**

- |               |                     |
|---------------|---------------------|
| 1. screw      | 2. VGA module cable |
| 3. VGA module | 4. control panel    |

## Related references

[Safety instructions](#) on page 59

## Related tasks

[Before working inside your system](#) on page 60

# Installing the VGA module

## Prerequisites

**CAUTION:** Many repairs may only be done by a certified service technician. You should only perform troubleshooting and simple repairs as authorized in your product documentation, or as directed by the online or telephone service and support team. Damage due to servicing that is not authorized by Dell is not covered by your warranty. Read and follow the safety instructions that are shipped with your product.

**NOTE:** This procedure applies only to the eight hard drive system.

1. Follow the safety guidelines listed in the Safety instructions section.
2. Keep the Philips #2 screwdriver ready.

## Steps

1. Push the VGA module into the chassis and align the threaded screw hole on the VGA module with the screw hole on the chassis.
2. Replace the screw (at the bottom of the chassis) that secures the VGA module to the chassis.
3. Replace the control panel.
4. Connect the VGA module cable to the VGA module.

**CAUTION:** The display module connector is a ZIF (zero insertion force) connector. Ensure that the locking tab on the connector is released before removal and insertion. The locking tab must be engaged after insertion.

5. Connect the display module cables to the control panel board.

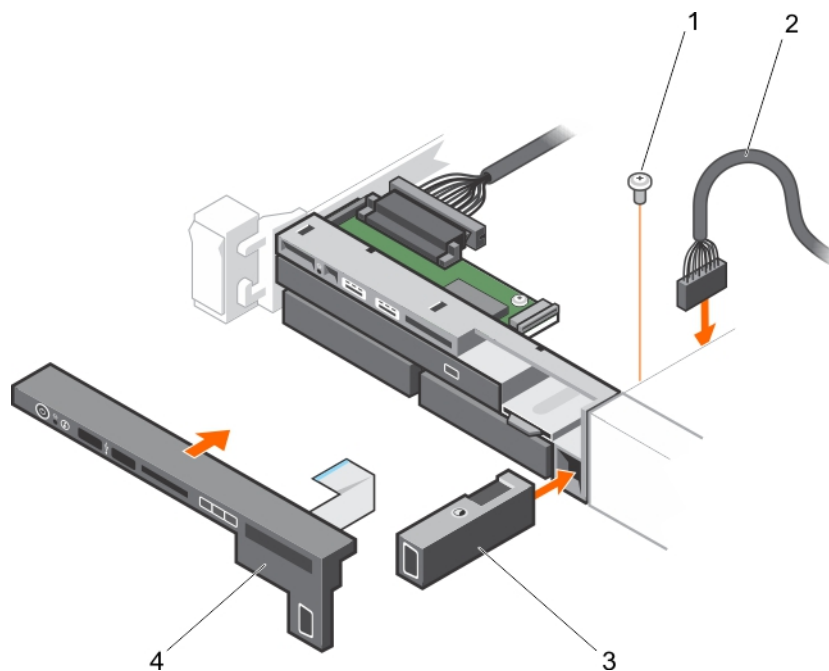

**Figure 64. Installing the VGA module**

- |               |                     |
|---------------|---------------------|
| 1. screw      | 2. VGA module cable |
| 3. VGA module | 4. control panel    |

## Next steps

Follow the procedure listed in the After working inside your system section.

## Related references

[Safety instructions](#) on page 59



## Related tasks

[After working inside your system](#) on page 60

# System board

## Removing the system board

### Prerequisites

-  **CAUTION:** Many repairs may only be done by a certified service technician. You should only perform troubleshooting and simple repairs as authorized in your product documentation, or as directed by the online or telephone service and support team. Damage due to servicing that is not authorized by Dell is not covered by your warranty. Read and follow the safety instructions that are shipped with your product.
-  **CAUTION:** If you are using the Trusted Platform Module (TPM) with an encryption key, you may be prompted to create a recovery key during program or System Setup. Be sure to create and safely store this recovery key. If you replace this system board, supply the recovery key when you restart your system or program before you can access the encrypted data on your hard drives.
-  **CAUTION:** Do not attempt to remove the TPM plug-in module from the system board. After the TPM plug-in module is installed, it is cryptographically bound to that specific system board. Any attempt to remove an installed TPM plug-in module breaks the cryptographic binding, and it cannot be re-installed or installed on another system board.

1. Follow the safety guidelines listed in the Safety instructions section.
2. Follow the procedure listed in the Before working inside your system section.
3. Remove the following:

- a. Cooling shroud
- b. Memory modules
- c. Cooling fans
- d. Power supply units
- e. All expansion card risers and expansion cards

 **NOTE:** The heat sink is hot to touch for some time after the system has been powered down. Ensure that you do not touch the heat sinks while removing the system board.

- f. Heat sinks or heat sink blanks and processors or processor blanks

 **CAUTION:** To prevent damage to the processor pins when replacing a faulty system board, ensure that you cover the processor socket with the processor protective cap.

- g. Integrated storage controller card
- h. Network daughter card
- i. Internal dual SD module
- j. Internal USB key (if installed)
- k. Hot-swap hard drives
- l. Hard drive backplane

 **CAUTION:** To avoid damaging the mini SAS cable and connector, follow the correct procedure when removing the mini SAS cable from the system board.

## Steps

1. Disconnect the mini SAS cable from the system board:
  - a. Push the mini SAS cable connector to slide it further into the connector on the system board.
  - b. Press down and hold the metal tab on the mini SAS cable connector.
  - c. Pull the mini SAS cable out of the connector on the system board.
2. Disconnect all other cables from the system board.
3. Grasp the system board holder, lift the blue release pin, slide the system board toward the front of the system, and lift the system board out of the chassis.

**CAUTION:** Do not to damage the system identification button while removing the system board from the chassis.

**CAUTION:** Do not lift the system board by holding a memory module, processor, or other components.

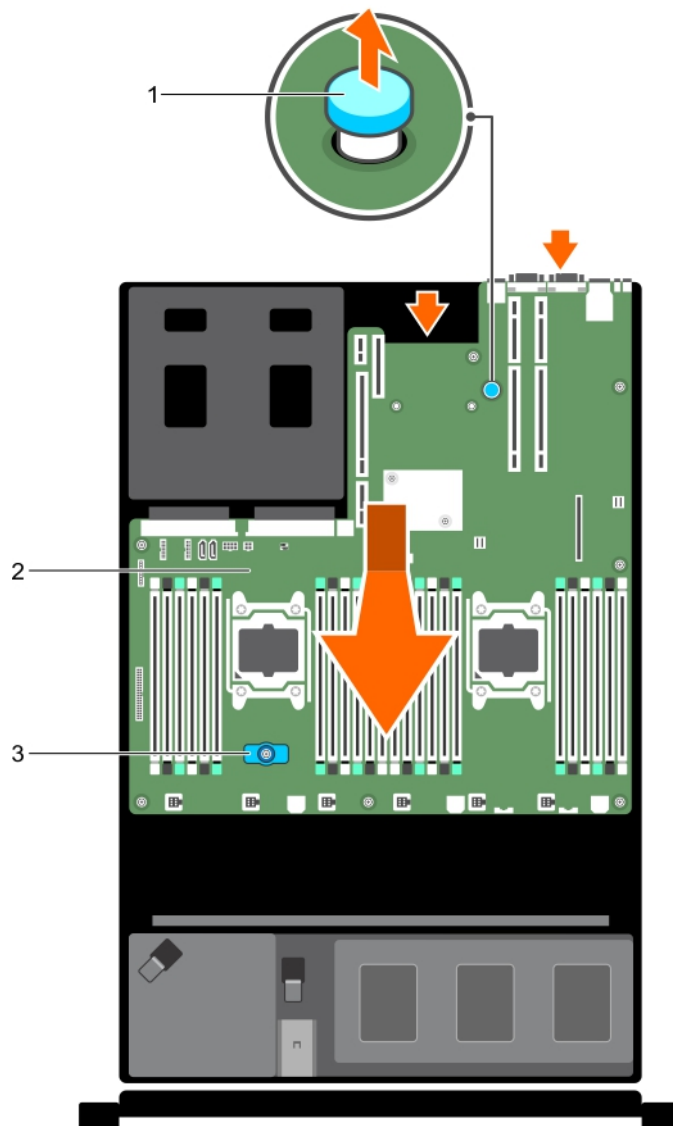

**Figure 65. Removing the system board**

- a. system board holder
- b. system board
- c. release pin

## Related references

[Safety instructions](#) on page 59

## Related tasks

[Before working inside your system](#) on page 60

# Installing the system board

## Prerequisites

 **CAUTION:** Many repairs may only be done by a certified service technician. You should only perform troubleshooting and simple repairs as authorized in your product documentation, or as directed by the online or telephone service and support team. Damage due to servicing that is not authorized by Dell is not covered by your warranty. Read and follow the safety instructions that are shipped with your product.

## Steps

1. Unpack the new system board assembly.

 **CAUTION:** Do not lift the system board by holding a memory module, processor, or other components.

 **CAUTION:** Do not damage the system identification button while placing the system board into the chassis.

2. Hold the touch points and lower the system board into the chassis.
3. Push the system board toward the back of the chassis until the board is seated correctly.

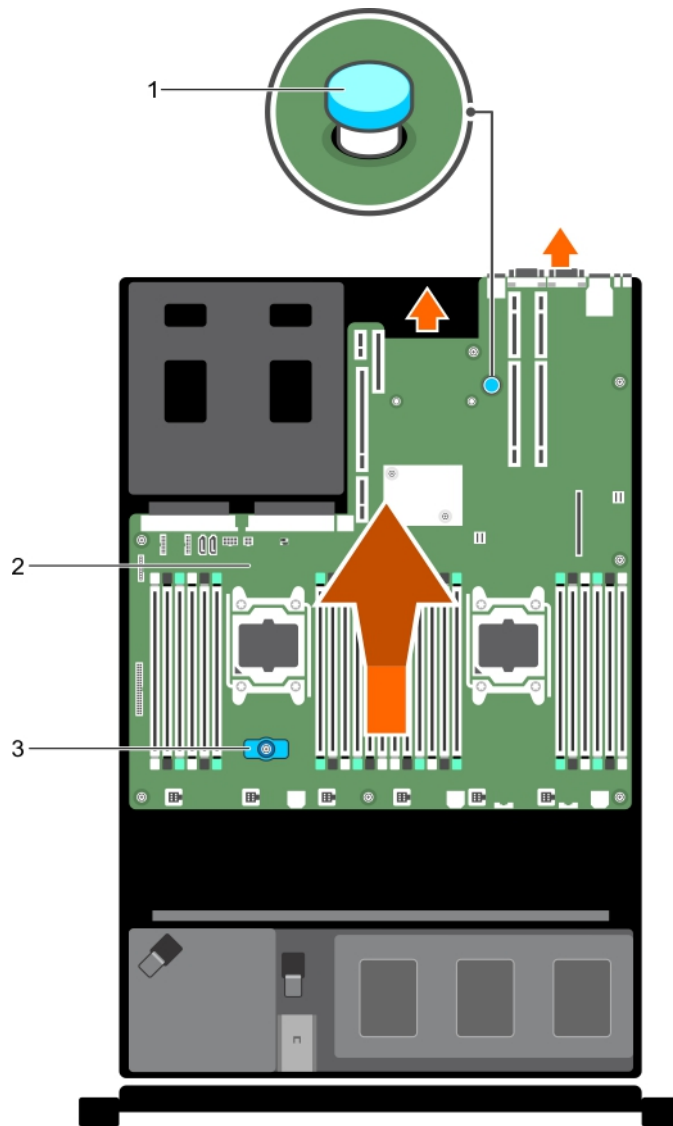

**Figure 66. Installing the system board**

- a. system board holder
- b. system board
- c. release pin

**Next steps**

1. Install the Trusted Platform Module (TPM). For information about how to install TPM, see the Installing the Trusted Platform Module section.
2. Replace the following:
  - a. Cable retention bracket
  - b. PCIe card holder
  - c. Integrated storage controller card
  - d. Internal USB key (if installed)
  - e. Internal dual SD module
  - f. All expansion card risers
  - g. Heat sinks or heat sink blanks and processors or processor blanks
  - h. Memory modules and memory module blanks
  - i. Network daughter card
  - j. Cooling fan assembly
  - k. Cooling shroud

- I. Power supply units
3. Reconnect all cables to the system board.
  - NOTE:** Ensure that the cables inside the system are routed along the chassis wall and secured by using the cable securing bracket.
4. Follow the procedure listed in the After working inside your system section.
5. Import your new or existing iDRAC Enterprise license. For more information, see the Integrated Dell Remote Access Controller User's Guide at [Dell.com/idracmanuals](https://Dell.com/idracmanuals).
6. Ensure that you:
  - a. Use the **Easy Restore** feature to restore the Service Tag. For more information, see the Restoring the Service Tag by using the Easy Restore feature section.
  - b. If the Service Tag is not backed up in the backup flash device, enter the system service tag manually. For more information, see the Entering the system service tag section.
  - c. Update the BIOS and iDRAC versions.
  - d. Re-enable the Trusted Platform Module (TPM). For more information, see the Re-enabling the TPM for BitLocker users or Re-enabling the TPM for Intel TXT users section.

### Related tasks

- [Installing the Trusted Platform Module](#) on page 126
- [After working inside your system](#) on page 60
- [Restoring the Service Tag by using the Easy Restore feature](#) on page 125
- [Entering the system Service Tag by using System Setup](#) on page 125
- [Initializing the TPM for BitLocker users](#) on page 127
- [Initializing the TPM for TXT users](#) on page 127

## Entering the system Service Tag by using System Setup

If Easy Restore fails to restore the Service Tag, use System Setup to enter the Service Tag.

### Steps

1. Turn on the system.
2. Press F2 to enter System Setup.
3. Click **Service Tag Settings**.
4. Enter the Service Tag.
  - NOTE:** You can enter the Service Tag only when the **Service Tag** field is empty. Ensure that you enter the correct Service Tag. After the Service Tag is entered, it cannot be updated or changed.
5. Click **Ok**.
6. Import your new or existing iDRAC Enterprise license.

For more information, see the *Integrated Dell Remote Access Controller User's Guide* at [Dell.com/idracmanuals](https://Dell.com/idracmanuals).

## Restoring the Service Tag by using the Easy Restore feature

The Easy Restore feature enables you to restore your system's Service Tag, license, UEFI configuration, and the system configuration data after replacing the system board. All data is automatically backed up in a backup flash device. If BIOS detects a new system board and the Service Tag in the backup flash device, BIOS prompts the user to restore the backup information.

### Steps

1. Turn on the system.

If BIOS detects a new system board, and if the Service Tag is present in the backup flash device, BIOS displays the Service Tag, the status of the license, and the **UEFI Diagnostics** version.
2. Perform one of the following steps:
  - Press **Y** to restore the Service Tag, license, and diagnostics information.
  - Press **N** to navigate to the Dell Lifecycle Controller based restore options.

- Press F10 to restore data from a previously created **Hardware Server Profile**.

After the restore process is complete, BIOS prompts to restore the system configuration data.

3. Perform one of the following steps:

- Press **Y** to restore the system configuration data.
- Press **N** to use the default configuration settings.

After the restore process is complete, the system restarts.

## Trusted Platform Module

Trusted Platform Module (TPM) is a dedicated microprocessor designed to secure hardware by integrating cryptographic keys into devices. A software can use a Trusted Platform Module to authenticate hardware devices. As each TPM chip has a unique and secret RSA key burned in as it is produced, it can perform the platform authentication.

**CAUTION:** Do not attempt to remove the Trusted Platform Module (TPM) from the system board. After the TPM is installed, it is cryptographically bound to that specific system board. Any attempt to remove an installed TPM breaks the cryptographic binding, and it cannot be re-installed or installed on another system board.

## Installing the Trusted Platform Module

### Prerequisites

**CAUTION:** Many repairs may only be done by a certified service technician. You should only perform troubleshooting and simple repairs as authorized in your product documentation, or as directed by the online or telephone service and support team. Damage due to servicing that is not authorized by Dell is not covered by your warranty. Read and follow the safety instructions that came with the product.

1. Follow the safety guidelines listed in the Safety instructions section.
2. Follow the procedure listed in the Before working inside your system section.

### Steps

1. Locate the Trusted Platform Module (TPM) connector on the system board.

**NOTE:** To locate the TPM connector on the system board, see the System board connectors section.

2. Align the edge connectors on the TPM with the slot on the TPM connector.
3. Insert the TPM into the TPM connector such that the plastic bolt aligns with the slot on the system board.
4. Press the plastic bolt until the bolt snaps into place.

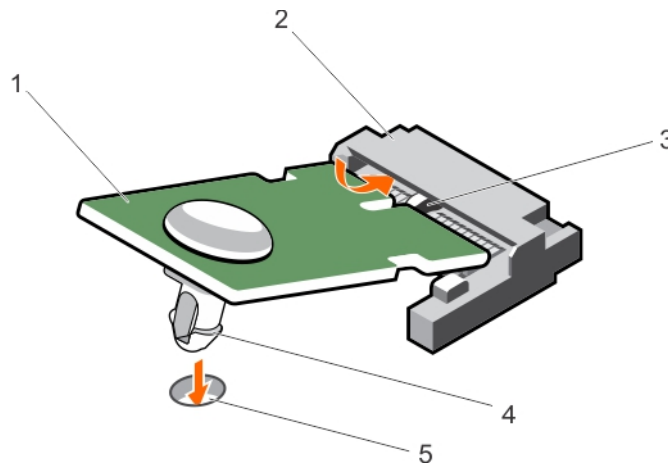

**Figure 67. Installing the TPM**

1. TPM
2. TPM connector
3. slot on the TPM connector
4. plastic bolt
- 5.

5. slot on the system board

### Next steps

1. Install the system board.
2. Follow the procedure listed in the After working inside your system section.

### Related references

[Safety instructions](#) on page 59

[System board jumpers and connectors](#) on page 131

### Related tasks

[Before working inside your system](#) on page 60

[After working inside your system](#) on page 60

## Initializing the TPM for BitLocker users

### Steps

Initialize the TPM.

For more information about initializing the TPM, see <http://technet.microsoft.com/en-us/library/cc753140.aspx>.

The **TPM Status** changes to **Enabled, Activated**.

## Initializing the TPM for TXT users

### Steps

1. While booting your system, press F2 to enter System Setup.
2. On the **System Setup Main Menu** screen, click **System BIOS** → **System Security Settings**.
3. From the **TPM Security** option, select **On with Pre-boot Measurements**.
4. From the **TPM Command** option, select **Activate**.
5. Save the settings.
6. Restart your system.
7. Enter **System Setup** again.
8. On the **System Setup Main Menu** screen, click **System BIOS** → **System Security Settings**.
9. From the **Intel TXT** option, select **On**.

# Using system diagnostics

If you experience a problem with your system, run the system diagnostics before contacting Dell for technical assistance. The purpose of running system diagnostics is to test your system hardware without requiring additional equipment or risking data loss. If you are unable to fix the problem yourself, service and support personnel can use the diagnostics results to help you solve the problem.

## Topics:

- [Dell Embedded System Diagnostics](#)

## Dell Embedded System Diagnostics

 **NOTE:** The Dell Embedded System Diagnostics is also known as Enhanced Pre-boot System Assessment (ePSA) diagnostics.

The Embedded System Diagnostics provides a set of options for particular device groups or devices allowing you to:

- Run tests automatically or in an interactive mode
- Repeat tests
- Display or save test results
- Run thorough tests to introduce additional test options to provide extra information about the failed device(s)
- View status messages that inform you if tests are completed successfully
- View error messages that inform you of problems encountered during testing

## When to use the Embedded System Diagnostics

If a major component or device in the system does not operate properly, running the embedded system diagnostics may indicate component failure.

## Running the Embedded System Diagnostics from Boot Manager

### Prerequisites

Run the Embedded System Diagnostics (ePSA) if your system does not boot.

### Steps

1. When the system is booting, press F11.
2. Use the up arrow and down arrow keys to select **System Utilities** > **Launch Diagnostics**.  
The **ePSA Pre-boot System Assessment** window is displayed, listing all devices detected in the system. The diagnostics starts executing the tests on all the detected devices.

## Running the Embedded System Diagnostics from the Dell Lifecycle Controller

### Steps

1. As the system boots, press F11.
2. Select **Hardware Diagnostics** → **Run Hardware Diagnostics**.  
The **ePSA Pre-boot System Assessment** window is displayed, listing all devices detected in the system. The diagnostics starts executing the tests on all the detected devices.

## System diagnostic controls

Menu	Description
<b>Configuration</b>	Displays the configuration and status information of all detected devices.
<b>Results</b>	Displays the results of all tests that are run.
<b>System health</b>	Provides the current overview of the system performance.
<b>Event log</b>	Displays a time-stamped log of the results of all tests run on the system. This is displayed if at least one event description is recorded.

For information about embedded system diagnostics, see the *ePSA Diagnostics Guide (Notebooks, Desktops and Servers)* available at [Dell.com/support/home](https://Dell.com/support/home).

# Jumpers and connectors

This topic provides specific information about the system jumpers. It also provides some basic information about jumpers and switches and describes the connectors on the various boards in the system. Jumpers on the system board help to disable system and setup passwords. You must know the connectors on the system board to install components and cables correctly.





## Topics:

- [System board jumper settings](#)
- [System board jumpers and connectors](#)
- [Disabling a forgotten password](#)

## System board jumper settings

For information about resetting the password jumper to disable a password, see the [Disabling a forgotten password](#) section.

**Table 37. System board jumper settings**

Jumper	Setting	Description
PWRD_EN	 2 4 6 (default) (default)	The password feature is enabled (pins 4–6).
	 2 4 6	The password feature is disabled (pins 2–4). iDRAC local access is unlocked at the next AC power cycle.
NVRAM_CLR	 1 3 5 (default) (default)	The configuration settings are retained at system boot (pins 1–3).
	 1 3 5	The configuration settings are cleared at the next system boot (pins 3–5).

### Related tasks

[Disabling a forgotten password](#) on page 133

# System board jumpers and connectors

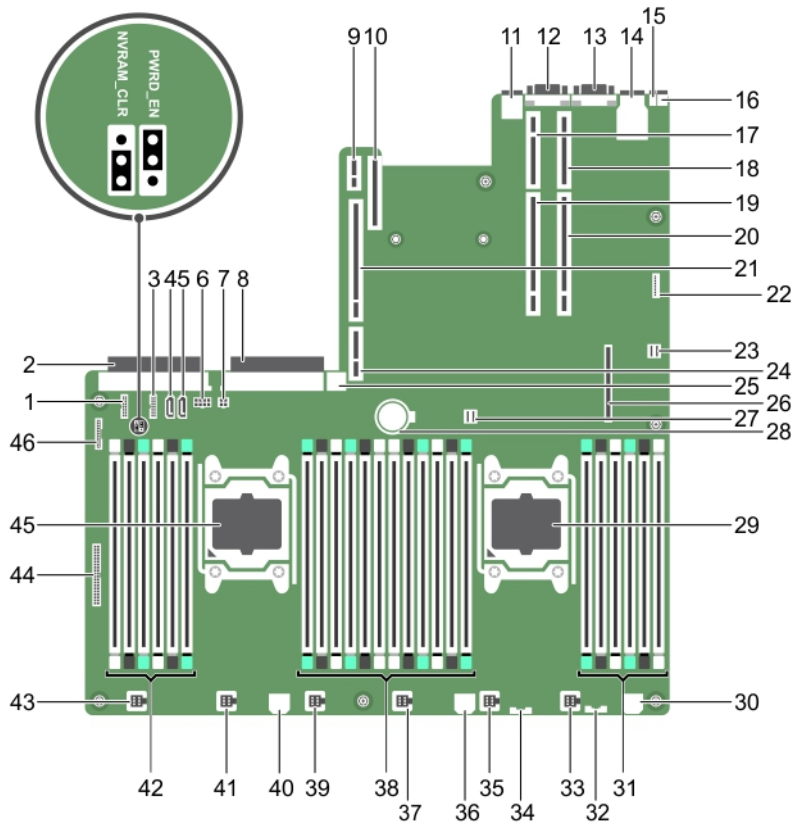

Figure 68. System board jumpers and connectors

Table 38. System board jumpers and connectors

Item	Connector	Description
1.	J_BP_SIG1	Backplane signal connector 1
2.	J_PS2	PSU 2 power connector
3.	J_BP_SIG0	Backplane signal connector 0
4.	J_SATA_CD	Optical drive SATA connector
5.	J_SATA_TBU	SATA tape backup unit connector
6.	J_BP0	Backplane power connector
7.	J_TBU	Tape backup unit power connector
8.	J_PS1	PSU 2 power connector
9.	J_IDSMD	Internal dual SD module connector <i>NOTE:</i> The Internal dual SD module connector is not supported for this release.
10.	J_NDC	Network daughter card connector
11.	J_USB	USB port
12.	J_VIDEO_REAR	Video connector
13.	J_COM1	Serial connector

**Table 38. System board jumpers and connectors (continued)**

<b>Item</b>	<b>Connector</b>	<b>Description</b>
14	J_IDRAC_RJ45	iDRAC7 connector
15	J_CYC	System identification connector
16	CYC_ID	System identification button
17	J_RISER_2AX	Riser 2 connector
18	J_RISER_1AX	Riser 1 connector
19	J_RISER_2BX	Riser 2 connector
20	J_RISER_1BX	Riser 1 connector
21	J_RISER_3AX	Riser 3 connector
22	J_SATA_B	SATA connector
23	J_QS	Quick Sync connector
24	J_RISER_3BX	Riser 3 connector
25	J_USB_INT	Internal USB port
26	J_STORAGE	Storage controller card connector
27	J_SATA_A	SATA connector
28	BAT	Battery connector
29	CPU2	Processor socket 2
30	J_FAN1U_7	Cooling fan connector
31	B1, B5, B9, B2, B6, B10	Memory module sockets
32	J_BP3	Hard drive backplane power connector
33	J_FAN1U_6	Cooling fan connector
34	J_BP_SIG2	Backplane signal connector 2
35	J_FAN1U_5	Cooling fan connector
36	J_BATT_SIG	Battery signal connector
37	J_FAN1U_4	Cooling fan connector
38	A1, A5, A9, A2, A6, A10, B3, B7, B11, B4, B8, B12	Memory module sockets
39	J_FAN1U_3	Cooling fan connector
40	J_FAN2U	Cooling fan connector
41	J_FAN1U_2	Cooling fan connector
42	A12, A8, A4, A7, A11, A3	Memory module sockets
43	J_FAN1U_1	Cooling fan connector
44	J_CTRL_PNL	Control panel connector
45	CPU1	Processor socket 1
46	J_FP_USB	Front panel USB port

# Disabling a forgotten password

The system's software security features include a system password and a setup password. The password jumper enables the password features or disables them and clears any passwords currently in use.

## Prerequisites

 **CAUTION:** Many repairs may only be done by a certified service technician. You should only perform troubleshooting and simple repairs as authorized in your product documentation, or as directed by the online or telephone service and support team. Damage due to servicing that is not authorized by Dell is not covered by your warranty. Read and follow the safety instructions that are shipped with your product.

## Steps

1. Turn off the system, including any attached peripherals, and disconnect the system from the electrical outlet.
2. Open the system.
3. Move the jumper on the system board jumper from pins 4 and 6 to pins 2 and 4.
4. Close the system.

The existing passwords are not disabled (erased) until the system boots with the jumper on pins 2 and 4. However, before you assign a new system and/or setup password, move the jumper back to pins 4 and 6.

 **NOTE:** If you assign a new system and/or setup password with the jumper on pins 2 and 4, the system disables the new passwords the next time it boots.

5. Reconnect the system to its electrical outlet and turn on the system, including any attached peripherals.
6. Turn off the system, including any attached peripherals, and disconnect the system from the electrical outlet.
7. Open the system.
8. Move the jumper on the system board jumper from pins 2 and 4 to pins 4 and 6.
9. Close the system.
10. Reconnect the system to its electrical outlet and turn on the system, including any attached peripherals.
11. Assign a new system and/or setup password.

# Troubleshooting your system

## Safety first — for you and your system

**CAUTION:** Many repairs may only be done by a certified service technician. You should only perform troubleshooting and simple repairs as authorized in your product documentation, or as directed by the online or telephone service and support team. Damage due to servicing that is not authorized by Dell is not covered by your warranty. Read and follow the safety instructions that are shipped with your product.

**NOTE:** Solution validation was performed by using the factory shipped hardware configuration.

### Topics:

- [Troubleshooting system startup failure](#)
- [Troubleshooting external connections](#)
- [Troubleshooting the video subsystem](#)
- [Troubleshooting a USB device](#)
- [Troubleshooting iDRAC Direct \(USB XML configuration\)](#)
- [Troubleshooting iDRAC Direct \(Laptop connection\)](#)
- [Troubleshooting a serial I/O device](#)
- [Troubleshooting a NIC](#)
- [Troubleshooting a wet system](#)
- [Troubleshooting a damaged system](#)
- [Troubleshooting the system battery](#)
- [Troubleshooting power supply units](#)
- [Troubleshooting cooling problems](#)
- [Troubleshooting cooling fans](#)
- [Troubleshooting system memory](#)
- [Troubleshooting an internal USB key](#)
- [Troubleshooting an optical drive](#)
- [Troubleshooting a tape backup unit](#)
- [Troubleshooting a hard drive](#)
- [Troubleshooting a storage controller](#)
- [Troubleshooting expansion cards](#)
- [Troubleshooting processors](#)

## Troubleshooting system startup failure

If you boot the system to the BIOS boot mode after installing an operating system from the UEFI Boot Manager, the system stops responding. To avoid this issue, you must boot to the same boot mode in which you installed the operating system.

For all other startup issues, note the system messages that appear on the screen.

## Troubleshooting external connections

Before troubleshooting any external devices, ensure that all external cables are securely attached to the external connectors on your system before troubleshooting any external devices.

# Troubleshooting the video subsystem

## Prerequisites

 **NOTE:** Ensure the **Local Server Video Enabled** option is selected in the iDRAC Graphical User Interface (GUI), under **Virtual Console**. If this option is not selected, local video is disabled.

## Steps

1. Check the cable connections (power and display) to the monitor.
2. Check the video interface cabling from the system to the monitor.
3. Run the appropriate diagnostic test.

## Results

If the tests run successfully, the problem is not related to video hardware.

## Next steps

If the tests fail, see the Getting help section.

## Related references

[Getting help](#) on page 147

# Troubleshooting a USB device

## Prerequisites

 **NOTE:** Follow steps 1 to 6 to troubleshoot a USB keyboard or mouse. For other USB devices, go to step 7.

## Steps

1. Disconnect the keyboard and/or mouse cables from the system and reconnect them.
2. If the problem persists, connect the keyboard and/or mouse to another USB port on the system.
3. If the problem is resolved, restart the system, enter System Setup, and check if the non-functioning USB ports are enabled.  
 **NOTE:** Older operating systems may not support USB 3.0.
4. Check if USB 3.0 is enabled in System Setup. If enabled, disable it and see if the issue is resolved.
5. In **iDRAC Settings Utility**, ensure that **USB Management Port Mode** is configured as **Automatic** or **Standard OS Use**.
6. If the problem is not resolved, replace the keyboard and/or mouse with a known working keyboard or mouse.  
If the problem is not resolved, proceed to step 7 to troubleshoot other USB devices attached to the system.
7. Turn off all attached USB devices, and disconnect them from the system.
8. Restart the system.
9. If your keyboard is functioning, enter System Setup, verify that all USB ports are enabled on the **Integrated Devices** screen. If your keyboard is not functioning, use remote access to enable or disable the USB options.
10. Check if USB 3.0 is enabled in System Setup. If it is enabled, disable it and restart your system.
11. If the system is not accessible, reset the NVRAM\_CLR jumper inside your system and restore the BIOS to the default settings. See the System board jumper setting section
12. In the **iDRAC Settings Utility**, ensure that **USB Management Port Mode** is configured as **Automatic** or **Standard OS Use**.
13. Reconnect and turn on each USB device one at a time.
14. If a USB device causes the same problem, turn off the device, replace the USB cable with a known good cable, and turn on the device.

### Next steps

If all troubleshooting fails, see the Getting help section.

### Related references

[Getting help](#) on page 147

## Troubleshooting iDRAC Direct (USB XML configuration)

For information about USB storage device and server configuration, see the Integrated Dell Remote Access Controller User's Guide at [Dell.com/idracmanuals](http://Dell.com/idracmanuals).

### Steps

1. Ensure that your USB storage device is connected to the front USB Management Port, identified by  icon.
2. Ensure that your USB storage device is configured with an NTFS or an FAT32 file system with only one partition.
3. Verify that the USB storage device is configured correctly. For more information about configuring the USB storage device, see the Integrated Dell Remote Access Controller User's Guide at [Dell.com/idracmanuals](http://Dell.com/idracmanuals).
4. In the **iDRAC Settings Utility**, ensure that **USB Management Port Mode** is configured as **Automatic** or **iDRAC Direct Only**.
5. Ensure that the **iDRAC Managed: USB XML Configuration** option is either **Enabled** or **Enabled only when the server has default credential settings**.
6. Remove and reinsert the USB storage device.
7. If import operation does not work, try with a different USB storage device.

### Next steps

If all troubleshooting fails, see the Getting help section.

### Related references

[Getting help](#) on page 147

## Troubleshooting iDRAC Direct (Laptop connection)

For information about USB laptop connection and server configuration, see the *Integrated Dell Remote Access Controller User's Guide* at [Dell.com/idracmanuals](http://Dell.com/idracmanuals).

### Steps

1. Ensure that your laptop is connected to the front USB Management Port, identified by  icon with a USB Type A/A cable.
2. On the **iDRAC Settings Utility** screen, ensure that **USB Management Port Mode** is configured as **Automatic** or **iDRAC Direct Only**.
3. If the laptop is running Windows operating system, ensure that the iDRAC Virtual USB NIC device driver is installed.
4. If the driver is installed, ensure that you are not connected to any network through WiFi or cabled ethernet, as iDRAC Direct uses a non-routable address.

### Next steps

If all troubleshooting fails, see the Getting help section.

### Related references

[Getting help](#) on page 147

# Troubleshooting a serial I/O device

## Steps

1. Turn off the system and any peripheral devices connected to the serial port.
2. Swap the serial interface cable with a known working cable, and turn on the system and the serial device.  
If the problem is resolved, replace the interface cable with a known working cable.
3. Turn off the system and the serial device, and swap the serial device with a compatible device.
4. Turn on the system and the serial device.

## Next steps

If the problem persists, see the Getting help section.

## Related references

[Getting help](#) on page 147

# Troubleshooting a NIC

## Steps

1. Run the appropriate diagnostic test. For more information, see the Using system diagnostics section for the available diagnostic tests.
2. Restart the system and check for any system messages pertaining to the NIC controller.
3. Check the appropriate indicator on the NIC connector:
  - If the link indicator does not glow, the cable connected might be disengaged.
  - If the activity indicator does not glow, the network driver files might be damaged or missing.  
Install or replace the drivers as necessary. For more information, see the NIC documentation.
  - If the problem persists, use another connector on the switch or hub.
4. Ensure that the appropriate drivers are installed and the protocols are bound. For more information, see the NIC documentation.
5. Enter System Setup and confirm that the NIC ports are enabled on the **Integrated Devices** screen.
6. Ensure that all the NICs, hubs, and switches on the network are set to the same data transmission speed and duplex. For more information, see the documentation for each network device.
7. Ensure that all network cables are of the proper type and do not exceed the maximum length.

## Next steps

If the problem persists, see the Getting help section.

## Related references

[Using system diagnostics](#) on page 128

[Getting help](#) on page 147

# Troubleshooting a wet system

## Prerequisites

 **CAUTION:** Many repairs may only be done by a certified service technician. You should only perform troubleshooting and simple repairs as authorized in your product documentation, or as directed by the online or telephone service and support team. Damage due to servicing that is not authorized by Dell is not covered by your warranty. Read and follow the safety instructions that are shipped with your product.

## Steps

1. Turn off the system and attached peripherals, and disconnect the system from the electrical outlet.
2. Remove the system cover.
3. Remove the following components (if installed) from the system:
  - power supply unit(s)
  - optical drive
  - hard drives
  - hard drive backplane
  - USB memory key
  - hard drive tray
  - cooling shroud
  - expansion card risers (if installed)
  - expansion cards
  - cooling fan assembly (if installed)
  - cooling fans
  - memory modules
  - processor(s) and heat sink(s)
  - system board
4. Let the system dry thoroughly for at least 24 hours.
5. Reinstall the components you removed in step 3 except the expansion cards.
6. Install the system cover.
7. Turn on the system and attached peripherals.  
If the problem persists, see the Getting help section.
8. If the system starts properly, shut down the system, and reinstall all the expansion cards that you removed.
9. Run the appropriate diagnostic test. For more information, see the Using system diagnostics section.

## Next steps

If the tests fail, see the Getting help section.

## Related references

[Getting help](#) on page 147

[Using system diagnostics](#) on page 128

# Troubleshooting a damaged system

## Prerequisites

 **CAUTION:** Many repairs may only be done by a certified service technician. You should only perform troubleshooting and simple repairs as authorized in your product documentation, or as directed by the online or telephone service and support team. Damage due to servicing that is not authorized by Dell is not covered by your warranty. Read and follow the safety instructions that are shipped with your product.

## Steps

1. Turn off the system and attached peripherals, and disconnect the system from the electrical outlet.
2. Remove the system cover.
3. Ensure that the following components are properly installed:
  - cooling shroud
  - expansion card risers (if installed)
  - expansion cards
  - power supply unit(s)
  - cooling fan assembly (if installed)

- cooling fans
- processor(s) and heat sink(s)
- memory modules
- hard drive carriers/cage
- hard drive backplane

4. Ensure that all cables are properly connected.
5. Install the system cover.
6. Run the appropriate diagnostic test. For more information, see the Using system diagnostics section.

### Next steps

If the problem persists, see the Getting help section.

### Related references

[Using system diagnostics](#) on page 128

[Getting help](#) on page 147

## Troubleshooting the system battery

### Prerequisites

**CAUTION:** Many repairs may only be done by a certified service technician. You should only perform troubleshooting and simple repairs as authorized in your product documentation, or as directed by the online or telephone service and support team. Damage due to servicing that is not authorized by Dell is not covered by your warranty. Read and follow the safety instructions that are shipped with your product.

**NOTE:** If the system is turned off for long periods of time (for weeks or months), the NVRAM may lose its system configuration information. This situation is caused by a defective battery.

**NOTE:** Some software may cause the system time to speed up or slow down. If the system seems to operate normally except for the time set in System Setup, the problem may be caused by a software, rather than by a defective battery.

### Steps

1. Re-enter the time and date in System Setup.
2. Turn off the system, and disconnect it from the electrical outlet for at least an hour.
3. Reconnect the system to the electrical outlet, and turn on the system.
4. Enter System Setup.

If the date and time displayed in System Setup are not correct, check the System Error Log (SEL) for system battery messages.

### Next steps

If the problem persists, see the Getting help section.

### Related references

[Getting help](#) on page 147

## Troubleshooting power supply units

### Prerequisites

**CAUTION:** Many repairs may only be done by a certified service technician. You should only perform troubleshooting and simple repairs as authorized in your product documentation, or as directed by the online or

**telephone service and support team. Damage due to servicing that is not authorized by Dell is not covered by your warranty. Read and follow the safety instructions that are shipped with your product.**

## Troubleshooting power source problems

### Steps

1. Press the power button to ensure that your system is turned on. If the power indicator does not glow when the power button is pressed, press the power button firmly.
2. Plug in another working power supply unit to ensure that the system board is not faulty.
3. Ensure that no loose connections exist.  
For example, loose power cables.
4. Ensure that the power source meets applicable standards.
5. Ensure that there are no short circuits.
6. Have a qualified electrician check the line voltage to ensure that it meets the needed specifications.

## Power supply unit problems

### Steps

1. Ensure that no loose connections exist.  
For example, loose power cables.
2. Ensure that the power supply handle or LED indicates that the power supply is working properly.  
For more information about power supply indicators, see the Power indicator codes section.
3. If you have recently upgraded your system, ensure that the power supply unit (PSU) has enough power to support the new system.
4. If you have a redundant power supply configuration, ensure that both the PSUs are of the same type and wattage.  
You may have to upgrade to a higher wattage PSU.
5. Ensure that you use only PSUs with the Extended Power Performance (EPP) label on the back.
6. Reseat the PSU.

 **NOTE:** After installing a PSU, allow several seconds for the system to recognize the PSU and determine if it is working properly.

If the problem persists, see the Getting help section.

### Related references

[Getting help](#) on page 147

[Power supply unit indicator codes](#) on page 15

## Troubleshooting cooling problems

 **CAUTION:** Many repairs may only be done by a certified service technician. You should only perform troubleshooting and simple repairs as authorized in your product documentation, or as directed by the online or telephone service and support team. Damage due to servicing that is not authorized by Dell is not covered by your warranty. Read and follow the safety instructions that are shipped with your product.

Ensure that the following conditions exist:

- System cover, cooling shroud, EMI filler panel, memory module blank, or back filler bracket is not removed.
- Ambient temperature is not higher than the system specific ambient temperature.
- External airflow is not obstructed.
- A cooling fan is not removed or has not failed.
- The expansion card installation guidelines have been followed.

Additional cooling can be added by one of the following methods:

From the iDRAC web GUI:

1. Click **Hardware > Fans > Setup**.
2. From the **Fan Speed Offset** drop-down list, select the cooling level required or set the minimum fan speed to a custom value.

From F2 System Setup:

1. Select **iDRAC Settings > Thermal**, and set a higher fan speed from the fan speed offset or minimum fan speed.

From RACADM commands:

1. Run the command `racadm help system.thermalsettings`

For more information, see the Integrated Dell Remote Access User's Guide at [Dell.com/idracmanuals](https://Dell.com/idracmanuals).

## Troubleshooting cooling fans

### Prerequisites

 **CAUTION:** Many repairs may only be done by a certified service technician. You should only perform troubleshooting and simple repairs as authorized in your product documentation, or as directed by the online or telephone service and support team. Damage due to servicing that is not authorized by Dell is not covered by your warranty. Read and follow the safety instructions that are shipped with your product.

 **NOTE:** The fan number is referenced by the systems management software. In the event of a problem with a particular fan, you can easily identify and replace it by noting down the fan numbers on the cooling fan assembly.

1. Follow the safety guidelines listed in safety instructions section.
2. Follow the procedure listed in the Before working inside your system section.

### Steps

1. Remove the system cover.
2. Reseat the fan or the fan's power cable.
3. Install the system cover.
4. Restart the system.

### Next steps

If the problem persists, see the Getting help section.

### Related references

[Safety instructions](#) on page 59

[Getting help](#) on page 147

### Related tasks

[Before working inside your system](#) on page 60

## Troubleshooting system memory

### Prerequisites

 **CAUTION:** Many repairs may only be done by a certified service technician. You should only perform troubleshooting and simple repairs as authorized in your product documentation, or as directed by the online or telephone service and support team. Damage due to servicing that is not authorized by Dell is not covered by your warranty. Read and follow the safety instructions that are shipped with your product.

## Steps

1. If the system is operational, run the appropriate system diagnostic test. See the Using system diagnostics section for the available diagnostic tests.  
If the diagnostic tests indicate a fault, follow the corrective actions provided by the diagnostic tests.
2. If the system is not operational, turn off the system and attached peripherals, and unplug the system from the power source. Wait at least for 10 seconds, and then reconnect the system to the power source.
3. Turn on the system and attached peripherals, and note the messages on the screen.  
If an error message is displayed indicating a fault with a specific memory module, go to step 12.
4. Enter System Setup, and check the system memory setting. Make any changes to the memory settings, if needed.  
If the memory settings match the installed memory but the problem still persists, go to step 12.
5. Turn off the system and attached peripherals, and disconnect the system from the electrical outlet.
6. Remove the system cover.
7. Check the memory channels and ensure that they are populated correctly.  
 **NOTE:** See the system event log or system messages for the location of the failed memory module. Reinstall the memory device.
8. Reseat the memory modules in their sockets.
9. Install the system cover.
10. Enter System Setup and check the system memory setting.  
If the problem is not resolved, proceed with step 11.
11. Remove the system cover.
12. If a diagnostic test or error message indicates a specific memory module as faulty, swap or replace the module with a known working memory module.
13. To troubleshoot an unspecified faulty memory module, replace the memory module in the first DIMM socket with a module of the same type and capacity.  
If an error message is displayed on the screen, this may indicate a problem with the installed DIMM type(s), incorrect DIMM installation, or defective DIMM(s). Follow the on-screen instructions to resolve the problem.
14. Install the system cover.
15. As the system boots, observe any error message that is displayed and the diagnostic indicators on the front of the system.
16. If the memory problem persists, repeat step 12 through step 15 for each memory module installed.

## Next steps

If the problem persists, see the Getting help section.

## Related references

[Getting help](#) on page 147

[Using system diagnostics](#) on page 128

# Troubleshooting an internal USB key

## Prerequisites

 **CAUTION:** Many repairs may only be done by a certified service technician. You should only perform troubleshooting and simple repairs as authorized in your product documentation, or as directed by the online or telephone service and support team. Damage due to servicing that is not authorized by Dell is not covered by your warranty. Read and follow the safety instructions that are shipped with your product.

## Steps

1. Enter System Setup and ensure that the **USB key port** is enabled on the **Integrated Devices** screen.
2. Turn off the system and attached peripherals, and disconnect the system from the electrical outlet.

3. Remove the system cover.
4. Locate the USB key and reseal it.
5. Install the system cover.
6. Turn on the system and attached peripherals, and check if the USB key is functioning.
7. If the problem is not resolved, repeat step 2 and step 3.
8. Insert a known working USB key.
9. Install the system cover.

#### Next steps

If the problem persists, see the Getting help section.

#### Related references

[Getting help](#) on page 147

## Troubleshooting an optical drive

#### Prerequisites

 **CAUTION:** Many repairs may only be done by a certified service technician. You should only perform troubleshooting and simple repairs as authorized in your product documentation, or as directed by the online or telephone service and support team. Damage due to servicing that is not authorized by Dell is not covered by your warranty. Read and follow the safety instructions that are shipped with your product.

#### Steps

1. Try using a different CD or DVD.
2. If the problem is not resolved, enter System Setup and ensure that the integrated SATA controller and the drive's SATA port are enabled.
3. Run the appropriate diagnostic test.
4. Turn off the system and attached peripherals, and disconnect the system from the electrical outlet.
5. If installed, remove the bezel.
6. Remove the system cover.
7. Ensure that the interface cable is securely connected to the optical drive and to the controller.
8. Ensure that a power cable is properly connected to the drive.
9. Install the system cover.

#### Next steps

If the problem persists, see the Getting help section.

#### Related references

[Getting help](#) on page 147

## Troubleshooting a tape backup unit

#### Prerequisites

 **CAUTION:** Many repairs may only be done by a certified service technician. You should only perform troubleshooting and simple repairs as authorized in your product documentation, or as directed by the online or telephone service and support team. Damage due to servicing that is not authorized by Dell is not covered by your warranty. Read and follow the safety instructions that are shipped with your product.

### Steps

1. Use a different tape cartridge.
2. Ensure that the device drivers for the tape backup unit are installed and are configured correctly. See your tape drive documentation for more information about device drivers.
3. Reinstall the tape-backup software as instructed in the tape-backup software documentation.
4. Ensure that the interface cable of the tape drive is connected to the external port on the controller card.
5. Perform the following steps to ensure that the controller card is properly installed:
  - a. Turn off the system and attached peripherals, and disconnect the system from the electrical outlet.
  - b. Remove the system cover.
  - c. Reseat the controller card in the expansion card slot.
  - d. Install the system cover.
  - e. Turn on the system and attached peripherals.
6. Run the appropriate diagnostic test. For more information, see the Using system diagnostics.

### Next steps

If you cannot resolve the problem, see the Getting help section.

### Related references

[Getting help](#) on page 147

## Troubleshooting a hard drive

### Prerequisites

 **CAUTION:** This troubleshooting procedure can erase data stored on the hard drive. Before you proceed, back up all files on the hard drive.

 **CAUTION:** Many repairs may only be done by a certified service technician. You should only perform troubleshooting and simple repairs as authorized in your product documentation, or as directed by the online or telephone service and support team. Damage due to servicing that is not authorized by Dell is not covered by your warranty. Read and follow the safety instructions that are shipped with your product.

### Steps

1. Run the appropriate diagnostic test. See the Using system diagnostics section.  
Depending on the results of the diagnostics test, proceed as needed through the following steps.
2. If your system has a RAID controller and your hard drives are configured in a RAID array, perform the following steps:
  - a. Restart the system and press F10 during system startup to run the Dell Lifecycle Controller, and then run the Hardware Configuration wizard to check the RAID configuration.  
See the Dell Lifecycle Controller documentation or online help for information about RAID configuration.
  - b. Ensure that the hard drives are configured correctly for the RAID array.
  - c. Take the hard drive offline and reseat the drive.
  - d. Exit the configuration utility and allow the system to boot to the operating system.
3. Ensure that the needed device drivers for your controller card are installed and are configured correctly. See the operating system documentation for more information.
4. Restart the system and enter the System Setup.
5. Verify that the controller is enabled and the drives are displayed in the System Setup.

### Next steps

If the problem persists, see the Getting help section.

### Related references

[Getting help](#) on page 147

## Troubleshooting a storage controller

**CAUTION:** Many repairs may only be done by a certified service technician. You should only perform troubleshooting and simple repairs as authorized in your product documentation, or as directed by the online or telephone service and support team. Damage due to servicing that is not authorized by Dell is not covered by your warranty. Read and follow the safety instructions that are shipped with your product.

**NOTE:** When troubleshooting a SAS or PERC controller, see the documentation for your operating system and the controller.

1. Run the appropriate diagnostic test. See the Using system diagnostics section.
2. Turn off the system and attached peripherals, and disconnect the system from the electrical outlet.
3. Remove the system cover.
4. Verify that the installed expansion cards are compliant with the expansion card installation guidelines.
5. Ensure that each expansion card is firmly seated in its connector.
6. Install the system cover.
7. Reconnect the system to the electrical outlet, and turn on the system and attached peripherals.
8. If the problem is not resolved, turn off the system and attached peripherals, and disconnect the system from the electrical outlet.
9. Remove the system cover.
10. Remove all expansion cards installed in the system.
11. Install the system cover.
12. Reconnect the system to the electrical outlet, and turn on the system and attached peripherals.
13. Run the appropriate diagnostic test. See the Using system diagnostics section. If the tests fail, see the Getting help section.
14. For each expansion card you removed in step 10, perform the following steps:
  - a. Turn off the system and attached peripherals, and disconnect the system from the electrical outlet.
  - b. Remove the system cover.
  - c. Reinstall one of the expansion cards.
  - d. Install the system cover.
  - e. Run the appropriate diagnostic test. See the Using system diagnostics section.

If the problem persists, see the Getting help section.

### Related references

[Using system diagnostics](#) on page 128

[Getting help](#) on page 147

## Troubleshooting expansion cards

### Prerequisites

**CAUTION:** Many repairs may only be done by a certified service technician. You should only perform troubleshooting and simple repairs as authorized in your product documentation, or as directed by the online or telephone service and support team. Damage due to servicing that is not authorized by Dell is not covered by your warranty. Read and follow the safety instructions that are shipped with your product.

**NOTE:** When troubleshooting an expansion card, you also have to see the documentation for your operating system and the expansion card.

### Steps

1. Run the appropriate diagnostic test. See the Using system diagnostics section.
2. Turn off the system and attached peripherals, and disconnect the system from the electrical outlet.
3. Remove the system cover.

4. Ensure that each expansion card is firmly seated in its connector.
5. Install the system cover.
6. Turn on the system and attached peripherals.
7. If the problem is not resolved, turn off the system and attached peripherals, and disconnect the system from the electrical outlet.
8. Remove the system cover.
9. Remove all expansion cards installed in the system.
10. Install the system cover.
11. Run the appropriate diagnostic test. See the Using system diagnostics section.  
If the tests fail, see the Getting help section.
12. For each expansion card you removed in step 8, perform the following steps:
  - a. Turn off the system and attached peripherals, and disconnect the system from the electrical outlet.
  - b. Remove the system cover.
  - c. Reinstall one of the expansion cards.
  - d. Install the system cover.
  - e. Run the appropriate diagnostic test. See the Using system diagnostics section.

### Next steps

If the problem persists, see the Getting help section.

### Related references

[Using system diagnostics](#) on page 128

[Getting help](#) on page 147

## Troubleshooting processors

### Prerequisites

 **CAUTION:** Many repairs may only be done by a certified service technician. You should only perform troubleshooting and simple repairs as authorized in your product documentation, or as directed by the online or telephone service and support team. Damage due to servicing that is not authorized by Dell is not covered by your warranty. Read and follow the safety instructions that are shipped with your product.

### Steps

1. Run the appropriate diagnostics test. See the Using system diagnostics section.
2. Turn off the system and attached peripherals, and disconnect the system from the electrical outlet.
3. Remove the system cover.
4. Ensure that the processor and heat sink are properly installed.
5. Install the system cover.
6. Run the appropriate diagnostic test. See the Using system diagnostics section.
7. If the problem persists, see the Getting help section.

### Related references

[Getting help](#) on page 147

[Using system diagnostics](#) on page 128

# Getting help

## Topics:

- [Contacting Dell](#)
- [Documentation feedback](#)
- [Quick resource locator](#)

## Contacting Dell

Dell provides several online and telephone-based support and service options. If you do not have an active internet connection, you can find contact information on your purchase invoice, packing slip, bill, or Dell product catalog. Availability varies by country and product, and some services may not be available in your area. To contact Dell for sales, technical assistance, or customer-service issues:

### Steps

1. Go to **Dell.com/support**.
2. Select your country from the drop-down menu on the bottom right corner of the page.
3. For customized support:
  - a. Enter your system Service Tag in the **Enter your Service Tag** field.
  - b. Click **Submit**.  
The support page that lists the various support categories is displayed.
4. For general support:
  - a. Select your product category.
  - b. Select your product segment.
  - c. Select your product.  
The support page that lists the various support categories is displayed.
5. For contact details of Dell Global Technical Support:
  - a. Click [Global Technical Support](#).
  - b. The **Technical Support** page is displayed with details to call, chat, or e-mail the Dell Global Technical Support team.

## Documentation feedback

You can rate the documentation or write your feedback on any of our Dell documentation pages and click **Send Feedback** to send your feedback.

## Quick resource locator

Use the Quick Resource Locator (QRL) to get immediate access to system information and how-to videos. This can be done by visiting **Dell.com/QRL**. To try out the QR code, scan the following image by using your smartphone or tablet.

# Quick Resource Locator



[Dell.com/QRL/Solutions/SDScalitySeries](https://Dell.com/QRL/Solutions/SDScalitySeries)