

Dell PowerStore

Installation and Service Guide for PowerStore 500T

Version 4.x

Notes, cautions, and warnings

 **NOTE:** A NOTE indicates important information that helps you make better use of your product.

 **CAUTION:** A CAUTION indicates either potential damage to hardware or loss of data and tells you how to avoid the problem.

 **WARNING:** A WARNING indicates a potential for property damage, personal injury, or death.

Additional Resources	8
Chapter 1: Install a new base enclosure and optional expansion enclosure	9
Install a new base enclosure.....	9
Installation power overview.....	9
Choose where to install the base enclosure.....	10
Unpack the base enclosure.....	10
Install the rails in the cabinet.....	10
Install the base enclosure on the rails.....	11
Cabling considerations.....	12
Cable the base enclosure appliance to switches.....	14
Connect power cables.....	14
Discover your system.....	14
Upgrade PowerStore software.....	15
Install an NVMe expansion enclosure.....	15
Summary of tasks for installing an expansion enclosure.....	15
Verify shipping package contents.....	15
Choose where to install the expansion enclosure.....	17
Removing a filler panel.....	17
Installing the NVMe expansion enclosure rails.....	17
Install the system in the cabinet.....	19
Installing cable management arms.....	21
Cable the base enclosure to the NVMe expansion enclosure.....	22
Closing the cable management arms.....	24
Testing the cable management arms.....	25
Installing drives.....	25
Installing the front bezel.....	26
Add an NVMe expansion enclosure.....	27
Summary of tasks for adding an expansion enclosure.....	27
Verify shipping package contents.....	28
Choose where to install the expansion enclosure.....	29
Removing a filler panel.....	29
Installing the NVMe expansion enclosure rails.....	29
Install the system in the cabinet.....	31
Installing cable management arms.....	33
Cable the new NVMe expansion enclosure.....	34
Closing the cable management arms.....	36
Testing the cable management arms.....	37
Attach the cables	37
Installing drives.....	37
Installing the front bezel.....	38
Chapter 2: Base enclosure service procedures	40
Replace a faulted drive in the base enclosure.....	40

Identify a faulted drive from PowerStore Manager.....	40
Remove a faulted 2.5" drive.....	40
Install a 2.5" drive.....	41
Verify the operation of a replacement drive.....	41
Return a faulted part.....	42
Add a new drive to the base enclosure.....	42
Removing the front bezel.....	42
Remove a drive filler module.....	42
Install a 2.5" drive.....	43
Verify the operation of an added drive.....	44
Replace an AC power supply.....	44
Identify a faulted power supply from PowerStore Manager.....	44
Base enclosure AC power supply.....	45
Remove a power supply.....	45
Install a power supply.....	46
Verify the operation of a replacement power supply.....	47
Return a faulted part.....	47
Replace a DC power supply.....	47
Identify a faulted power supply from PowerStore Manager.....	48
Base enclosure DC power supply.....	48
Remove a DC power supply.....	48
Install a DC power supply.....	49
Verify the operation of a replacement power supply.....	50
Return a faulted part.....	50
Replace a 4-port card.....	51
Before you begin.....	51
Identify a faulted 4-port card from PowerStore Manager.....	51
Embedded module LEDs.....	51
Power down the node.....	52
Remove the node.....	52
Remove the embedded module cover from the node.....	54
Remove a 4-port card.....	55
Install a 4-port card.....	56
Install the embedded module cover.....	57
Install the node.....	58
Power up the node.....	58
Verify the operation of a new 4-port card.....	59
Return a faulted part.....	59
Replace an SFP.....	59
Identify a faulted SFP module from PowerStore Manager.....	59
Remove an SFP module.....	60
Install an SFP module.....	60
Verify the operation of a replacement SFP module.....	60
Return a faulted part.....	61
Replace an I/O module.....	61
Before you begin.....	61
Identify a faulted I/O module from PowerStore Manager.....	61
Base enclosure I/O module LEDs.....	62
Power down the node.....	62
Remove an I/O module.....	62

Install an I/O module.....	63
Power up the node.....	63
Verify the operation of a replacement I/O module.....	64
Return a faulted part.....	64
Replace a fan module.....	64
Before you begin.....	64
Identify a faulted fan module from PowerStore Manager.....	64
Power down the node.....	65
Remove the node.....	65
Remove the top cover from the node.....	66
Remove the fan module.....	67
Install the fan module.....	68
Install the top cover on the node.....	68
Install the node.....	69
Verify the operation of a replacement fan module.....	70
Return a faulted part.....	70
Replace a dual inline memory module (DIMM).....	71
Before you begin.....	71
Identify a faulted DIMM from PowerStore Manager.....	71
Power down the node.....	71
Remove the node.....	71
Remove the top cover from the node.....	73
Remove the dual inline memory module.....	74
Install the dual inline memory module.....	74
Install the top cover on the node.....	75
Install the node.....	76
Verify the operation of a replacement DIMM.....	76
Return a faulted part.....	77
Replace an internal M.2 boot module.....	77
Before you begin.....	77
Identify a faulted internal M.2 boot module from PowerStore Manager.....	77
Establish connectivity to the peer node via SSH.....	78
Power down the node.....	78
Remove the node.....	78
Remove the top cover from the node.....	80
Remove the internal M.2 boot module.....	80
Install the internal M.2 boot module.....	81
Install the top cover on the node.....	82
Install the node.....	82
Reimage the new internal M.2 boot module.....	83
Verify the operation of a replacement internal M.2 boot module.....	84
Return a faulted part.....	85

Chapter 3: NVMe expansion enclosure service procedures..... 86

Replace a faulted drive in an NVMe expansion enclosure.....	86
Identify a faulted drive from PowerStore Manager.....	86
Removing the front bezel.....	86
Remove a faulted drive.....	87
Installing a drive.....	88
Installing the front bezel.....	88

Verify the operation of a replacement drive.....	89
Return a faulted part.....	89
Add a drive in an NVMe expansion enclosure.....	89
Removing the front bezel.....	89
Remove a drive filler module.....	90
Installing a drive.....	91
Installing the front bezel.....	91
Verify the operation of an added drive.....	92
Replace a power supply module in an NVMe expansion enclosure.....	92
Identify a faulted power supply from PowerStore Manager.....	92
NVMe expansion enclosure power supply LEDs.....	93
Remove a power supply.....	93
Install a power supply.....	94
Verify the operation of a replacement power supply.....	95
Return a faulted part.....	95
Replace a fan module in an NVMe expansion enclosure.....	96
Identify a faulted fan module from PowerStore Manager.....	96
Remove a fan module.....	96
Install a fan module.....	98
Verify the operation of a replacement fan module.....	100
Return a faulted part.....	100
Replace a Clock Distribution Board in an NVMe expansion enclosure.....	101
Identify a faulted Clock Distribution Board from PowerStore Manager.....	101
Remove a Clock Distribution Board.....	101
Install a Clock Distribution Board.....	103
Verify the operation of a replacement Clock Distribution Board.....	105
Return a faulted part.....	105
Replace an Access Module in an NVMe expansion enclosure.....	106
Identify a faulted Access Module from PowerStore Manager.....	106
Remove an Access Module.....	106
Install an Access Module.....	107
Verify the operation of a replacement Access Module.....	108
Return a faulted part.....	109
Replace a data interface board in an NVMe expansion enclosure.....	109
Identify a faulted DIB from PowerStore Manager.....	109
Removing a DIB.....	109
Replacing a DIB.....	111
Verify the operation of a replacement DIB.....	112
Return a faulted part.....	112
Replace a dual inline memory module (DIMM).....	112
Identify a faulted DIMM from PowerStore Manager.....	112
Remove an Access Module.....	113
Remove the faulted dual inline memory module.....	114
Install the dual inline memory module.....	115
Install an Access Module.....	115
Verify the operation of a replacement DIMM.....	116
Return a faulted part.....	117
Appendix A: Safety precautions for handling replaceable units.....	118
Handling replaceable units.....	118

Avoid electrostatic discharge (ESD) damage	118
Emergency procedures (without an electrostatic discharge kit).....	118
Hardware acclimation times.....	119
Remove, install, or store replaceable units.....	119
Unpack a part.....	120
Appendix B: Power control procedures.....	121
Power control procedure considerations.....	121
Power control procedures preview.....	121
Powering off procedures for PowerStore node.....	122
Power off a node using PowerStore Manager.....	122
Power off a node using a service script.....	123
Powering on procedures for PowerStore node.....	123
Power on a node using a service script.....	124
Power on a node by reseating the node.....	124
Rebooting procedures for a PowerStore node.....	124
Reboot a node using PowerStore Manager.....	124
Reboot a node using a service script.....	125
Power off an appliance.....	125
Power on an appliance.....	126
Power off a cluster using PowerStore Manager.....	127
Power on a cluster.....	127
Appendix C: Data collection.....	129
Support materials collection.....	129
Collect support materials.....	129
Appendix D: Maintenance windows.....	131
Enable a maintenance window.....	131
Disable a maintenance window.....	131
Appendix E: Add appliances to the cluster.....	132
Add appliances to the cluster.....	132
Appendix F: Remove appliances from the cluster.....	134
Remove an appliance from a cluster.....	134
Migrate storage objects from an appliance.....	135
Appendix G: Reinitialize the system.....	136
Reinitialize the system.....	136

As part of an improvement effort, revisions of the software and hardware are periodically released. Some functions that are described in this document are not supported by all versions of the software or hardware currently in use. The product release notes provide the most up-to-date information about product features. Contact your service provider if a product does not function properly or does not function as described in this document.

Where to get help

Support, product, and licensing information can be obtained as follows:

- **Product information**—For product and feature documentation or release notes, go to the [PowerStore Info Hub](#).
- **Troubleshooting**—For information about products, software updates, licensing, and service go to [Dell Support](#) and locate the appropriate product support page.
- **Technical support**—For technical support and service requests, go to [Dell Support](#) and locate the **Service Requests** page. To open a service request, you must have a valid support agreement. Contact your Sales Representative for details about obtaining a valid support agreement or to answer any questions about your account.

Customer feedback

A feedback button is located at the right side of the PowerStore Manager. Selecting **Feedback** opens a browser window where you can fill and submit a feedback survey.

Install a new base enclosure and optional expansion enclosure

Follow these procedures to add a new base enclosure and an optional expansion enclosure to the system. For a detailed overview of these components, see the *PowerStore Hardware Information Guide*.

NOTE: Review the information in [Safety precautions for handling replaceable units](#) before handling parts.

Topics:

- [Install a new base enclosure](#)
- [Install an NVMe expansion enclosure](#)
- [Add an NVMe expansion enclosure](#)

Install a new base enclosure

Take the following actions to install a new base enclosure into a rack.

Installation power overview

Follow these guidelines for when to power on your system during various installation scenarios.

Table 1. Installing expansion enclosures during the initial system installation

Installation Scenario	Order of Operations
Installing only a base enclosure	<ol style="list-style-type: none"> 1. Install the base enclosure. 2. Plug in the power cables.
Installing a base enclosure and expansion enclosures	<ol style="list-style-type: none"> 1. Install the base enclosure and expansion enclosures. 2. Cable the expansion enclosures to the base enclosure. 3. Plug in the power cables.

Table 2. Adding expansion enclosures to a running system

Installation Scenario	Order of Operations
Adding the first expansion enclosure	<ol style="list-style-type: none"> 1. Install the expansion enclosure. 2. Cable the expansion enclosures to the base enclosure. 3. Plug in the power cables.
Adding a second expansion enclosure	<ol style="list-style-type: none"> 1. Install the expansion enclosure. 2. Plug in the power cables. 3. Move the loopback cables and then add two new cables.
Adding a third expansion enclosure	<ol style="list-style-type: none"> 1. Install the expansion enclosure. 2. Plug in the power cables. 3. Move loopback cables and then add two new cables.

Choose where to install the base enclosure

Before installing the new base enclosure, determine the placement of the new base enclosure within the rack.

Steps

1. Install the base enclosure in the lowest available 2U space, leaving 2U of space at the bottom of the rack for serviceability. Most cabinets mark 1U increments with horizontal lines or small holes in the channels.
2. If this is the second base enclosure to be installed in the rack, install it directly into the 2U space above the first base enclosure.
i **NOTE:** For additional rack space considerations, see the *PowerStore Planning Guide*.
3. Considering these recommendations, choose a 2U space in the cabinet for the base enclosure.
i **NOTE:** It is recommended that you include 92 cm (36 in.) of clearance in front of and behind the rack to avoid a system shutdown if maintenance or service activities are required.

Unpack the base enclosure

The base enclosure is a 2U component with 25 2.5" drive slots. Verify that you have received all of the base enclosure components in the shipping package.

- i** **NOTE:** Before installing the base enclosure, ensure that the hardware has acclimated to the operating environment as described in [Hardware acclimation times](#).

Verify shipping package contents

Confirm that you received all necessary equipment needed to install the new base enclosure.

- Base enclosure - 2U component with 25 2.5" drive slots
- One tool-less rail kit that includes two snap-in rails
- Two security screws
- Power cords: Two AC power cords for AC systems or two DC power cords for DC systems
- One bezel

Install the rails in the cabinet

This task describes the procedure to install one rail. After installing one rail, repeat the procedure for the other rail. The procedure is the same for both the left and right rail. You can install the rails into either a square or round hole rack.

Steps

1. Position the rail end piece so the label FRONT is at the front of the rack and facing towards the inside of the rack, while orienting the rear of the rail to align level with the holes on the rear of the rack.
2. From the rear of the rack, pull the rail straight back until the latch is locked.
3. To install the frontend piece of the rail, press the blue latch release button until the latch rotates open.
4. Pull the rail forward until the pins slide into the holes on the front of the rack, then release the latch to secure the rail in place.

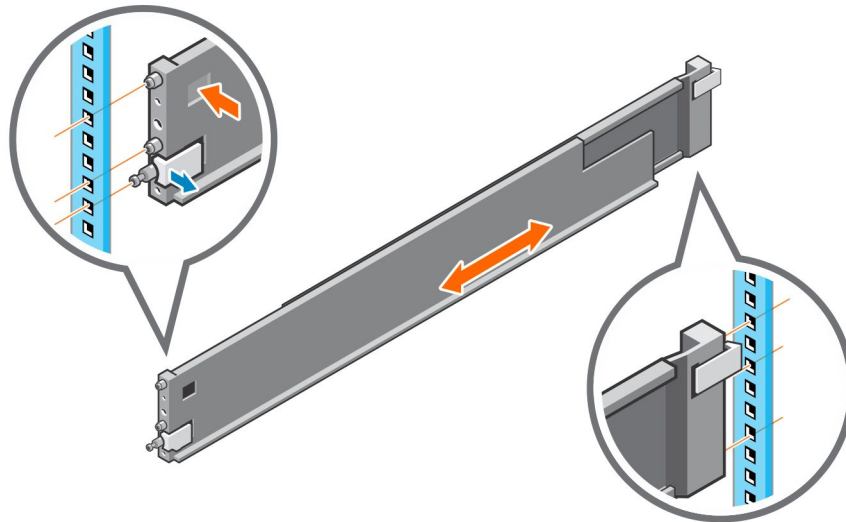

Figure 1. Installing the rails

5. Repeat for the other rail.
6. The rail kit ships with two screws for additional security. Install the security screws into the rear of the rails in the screw hole next to the blue spring lock.

NOTE: You may need a long-handled screwdriver to reach the screw hole.

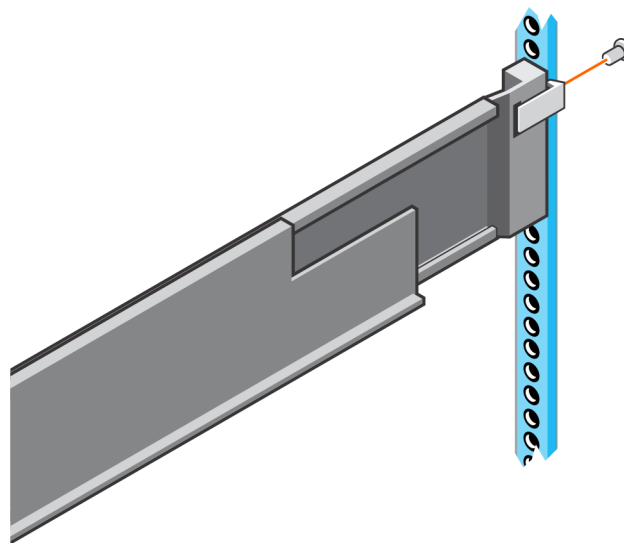

Figure 2. Installing the security screws

Install the base enclosure on the rails

Steps

1. Lift the enclosure and slide it onto the rails from the front of the cabinet.
2. Push the enclosure into the rack until the slam latches engage and lock the enclosure into the rack. Ensure that the enclosure is flush with the front of the rack, fully seated in the cabinet, and does not slide out.

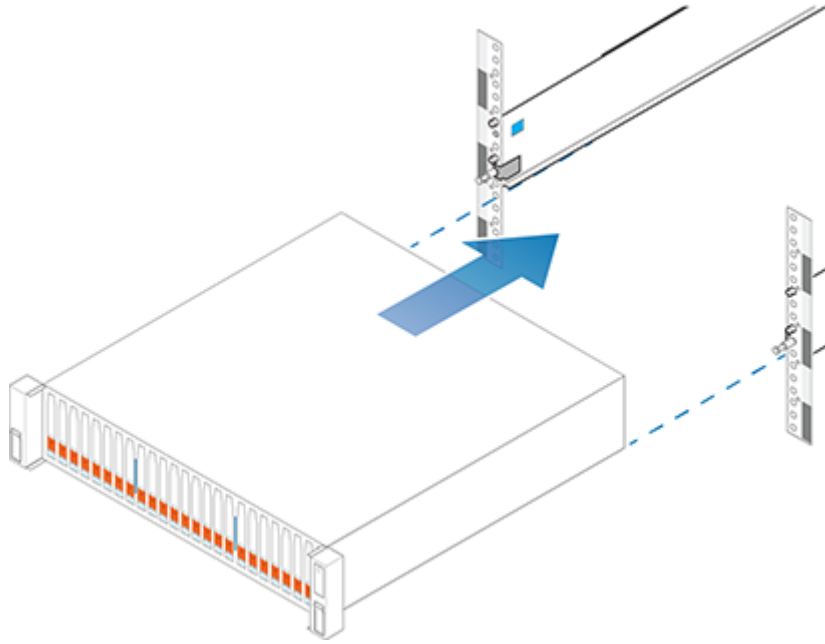

Figure 3. Installing the enclosure

3. The enclosure includes captive screws under the front latches. Locate the captive screw under each latch and tighten to the front of the cabinet using a #1 Philips screwdriver.

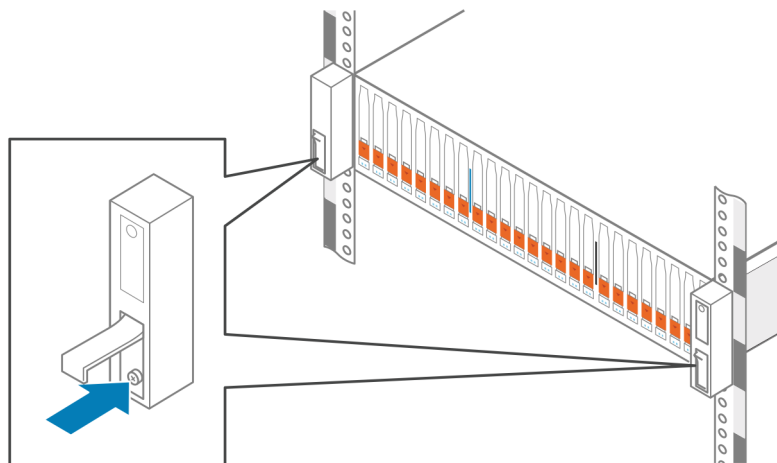
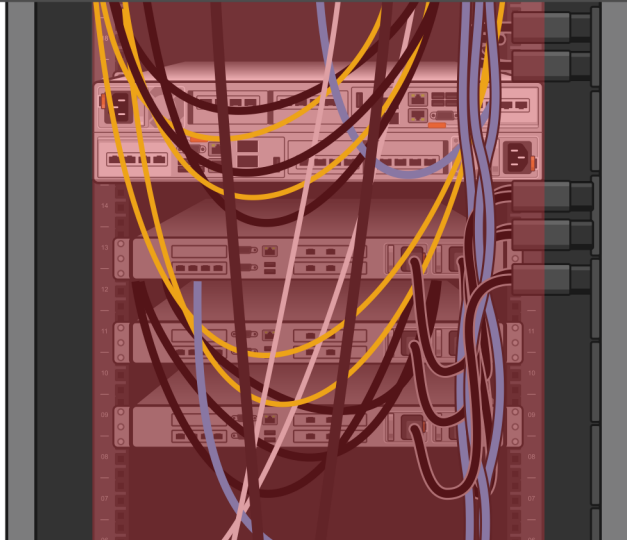
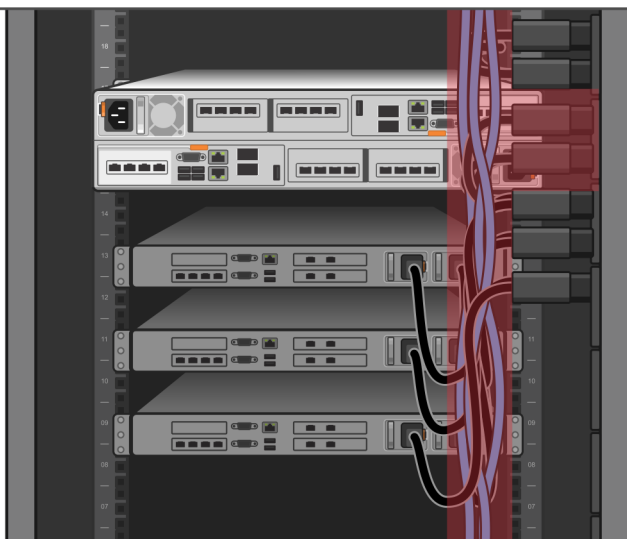
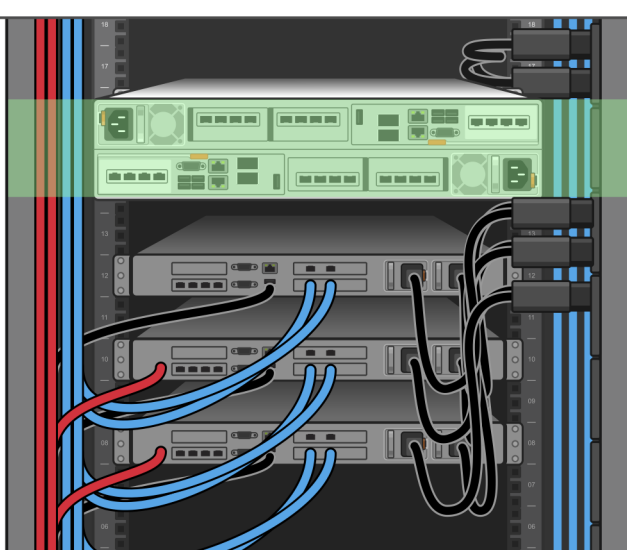

Figure 4. Tightening the captive screws

Cabling considerations

When installing or servicing the system, ensure that the network and power cables do not obstruct node removal. The node spans the full rack width and requires 36 inches of rear clearance for extraction. Some third-party racks allow inward-facing PDU placement. Verify that the power plugs allow unobstructed node removal. Any obstruction may delay service replacement maintenance and require a scheduled maintenance window.

Table 3. Cabling examples

Example	Description
	Obstructive network cabling
	Obstructive PDU placement i NOTE: The placement of the PDU cables is only an issue for racks with inward-facing PDUs.
	Non-obstructive network cabling and PDU placement

Cable the base enclosure appliance to switches

For switch cabling information, refer to the *PowerStore Networking Guide for Initial Deployment* .

NOTE: Do not connect the power cables until you have completed network configuration.

Connect power cables

About this task

NOTE: The figures below show an AC power supply.

Steps

1. Plug each power cable into the base enclosure power supply.

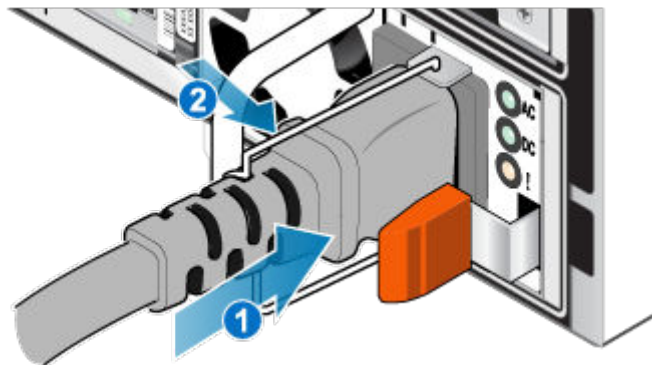

Figure 5. Inserting the power cable

2. Connect the other end of the power cable to the power distribution unit (PDU) on the rack.

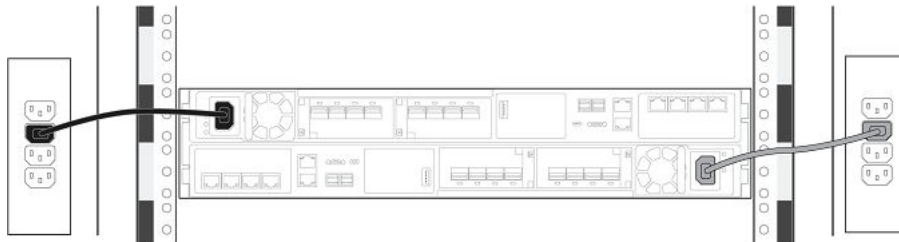

Figure 6. Connecting to the PDU

After you connect the power cables, the base enclosure automatically starts up.

Discover your system

Once you have completed installing your base enclosure, discover your newly installed enclosure.

Refer to the *PowerStore Networking Guide for Initial Deployment* for details.

Upgrade PowerStore software

PowerStore systems come preinstalled with the latest version of PowerStore software that was available at the time of shipment. After installing the PowerStore system, Dell Technologies recommends upgrading the PowerStore software to the latest available version. See the *PowerStore Software Upgrade Guide* for detailed instructions.

Install an NVMe expansion enclosure

Take the following actions to install an NVMe expansion enclosure into the system during the initial system installation or to install the first NVMe expansion enclosure into a running system.

NOTE: During the initial system installation, do not power on the system until you have finished cabling all of the expansion enclosures.

CAUTION: On a running cluster, if you are adding an expansion enclosure after installing the first expansion enclosure during initial system installation, you must power on the new expansion enclosure before attaching the back-end cables. Review [Installation power overview](#) before proceeding.

Summary of tasks for installing an expansion enclosure

To install an expansion enclosure, complete the tasks below in the order in which they appear. This document provides instructions for completing each task.

1. Verify the contents of the shipping package.
2. Choose the space in the cabinet for the new expansion enclosure.
3. Remove the filler panels that cover the cabinet space for the new expansion enclosure.
4. Install the rails for the new expansion enclosure in the cabinet.
5. Install the expansion enclosure on the rails.
6. Install the cable management arms.
7. Apply cable labels.
8. Review [Installation power overview](#).
9. Attach the expansion (back-end) cables, and then attach the power cables.
10. Close the cable management arms.
11. Test the cable management arms.
12. If the new expansion enclosure shipped without its drives installed, install the drives in the expansion enclosure.
13. Install the front bezel on the new expansion enclosure.

Verify shipping package contents

Confirm that you received all the equipment that is required to install the new NVMe expansion enclosure.

Verify that you received the following:

Table 4. NVMe expansion enclosure shipping package contents

Component	Quantity
NVMe expansion enclosure	1



Table 4. NVMe expansion enclosure shipping package contents (continued)



Component		Quantity
Rail kit, including Snap-in rails (2) Screws (2 per rail)		1
Cable management arms		2
Power cords, either Black and gray C13/C14 Black and gray C13/C20		2
Bezel for NVMe expansion enclosure (with key)		1
100G QSFP28 to Single SFP28 (25GB copper) cables to connect the base enclosure to the NVMe expansion enclosure. 100G QSFP28 cables to connect the NVMe expansion enclosure to another NVMe expansion enclosure, and to loopback from the NVMe expansion enclosure to the base enclosure. ⓘ NOTE: The first NVMe expansion enclosure ships with four 100G QSFP28 to Single	 <p data-bbox="443 1832 1106 1865">Figure 7. 100G QSFP28 to Single SFP28 (25GB copper)</p>	2

Table 4. NVMe expansion enclosure shipping package contents (continued)

Component		Quantity
<p>SFP28 (25GB copper) cables. The second and third NVMe expansion enclosure ship with two 100G QSFP28 cables.</p>	<div style="text-align: center;">  <p>Figure 8. 100G QSFP28 to 100G QSFP28</p> </div>	

Choose where to install the expansion enclosure

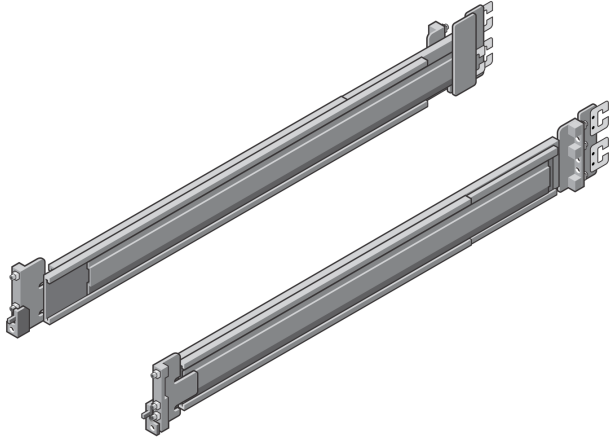
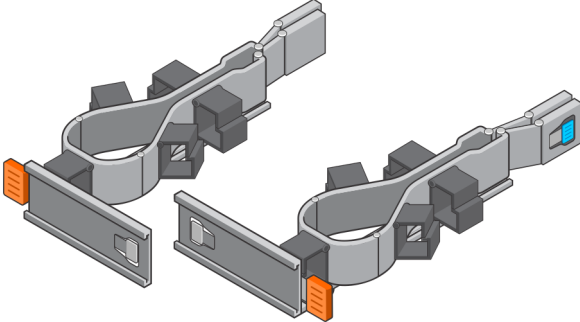
Before installing the new expansion enclosure, you should determine the placement of the new expansion enclosure within the rack.

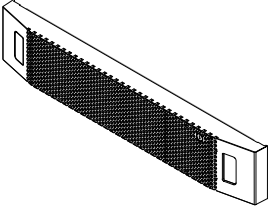
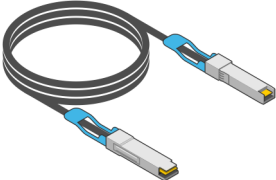
Steps

1. It is recommended that you install the expansion enclosure in the next available 2U space directly above the base enclosure or the last expansion enclosure in the system.
Most cabinets mark 1U increments with horizontal lines or small holes in the channels.
2. Considering these recommendations, choose a 2U space in the cabinet for the expansion enclosure.

Removing a filler panel

About this task

In most cases, the front space into which you will install the enclosure is covered by a filler panel.

Steps

If one or more filler panels cover the space where you want to install the enclosure, remove each panel.

Installing the NVMe expansion enclosure rails

About this task

Install the rails from the front of the cabinet into which you are installing the enclosure. The 2U NVMe expansion enclosure includes rails that slide into the cabinet rail assembly. The rails are dedicated left and right, and cannot be interchanged. The front side of each rail is labeled Left Front or Right Front.

Steps

1. Locate the 2U cabinet space designated for the enclosure.
2. Install the right rail to the rear NEMA channel.
 - a. Align the right rail with the lower U of the allotted 2U space.
 - b. Push the rail back to secure the rail posts in the cabinet NEMA channel. An audible click indicates that the rail is secure in the channel.
3. Install the right rail to the front NEMA channel.
 - a. Align the front of the right rail so that it is level.
 - b. Pull the rail forward while holding the rail clamp open.
 - c. Once the rail posts are in the cabinet NEMA channel, release the rail clamp. An audible click indicates that the connection is secure.

4. Install the left rail by mirroring steps 2 and 3.

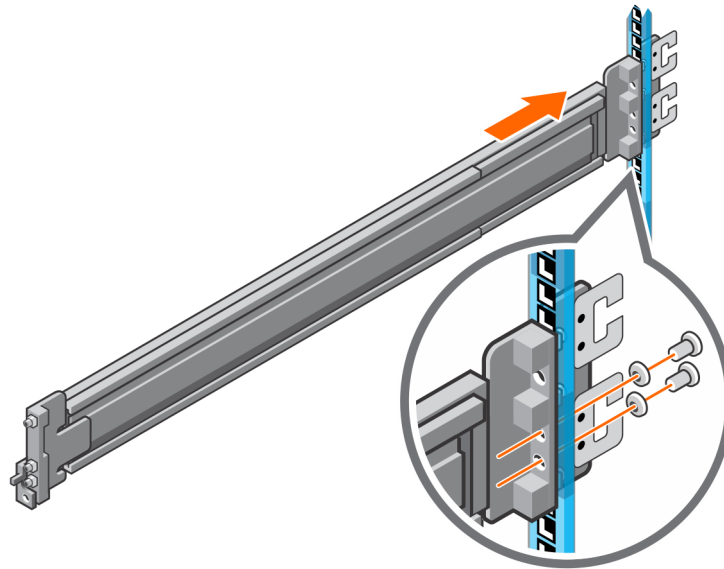

Figure 9. Installing the NVMe expansion enclosure rails (rear)

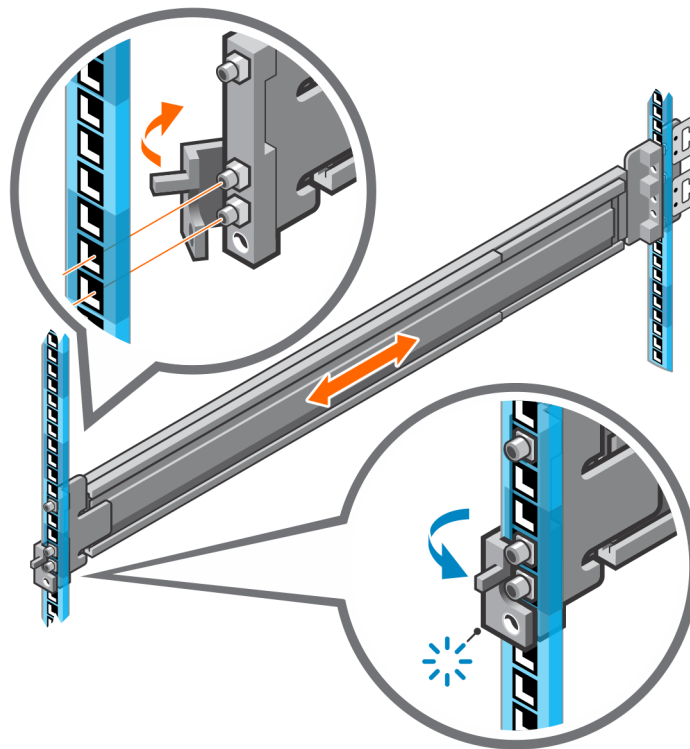

Figure 10. Installing the NVMe expansion enclosure rails (front)

5. Add the retaining screws that came with the rails to the front and back of both rails.

(i) NOTE: Use the washers that came with the rails if the rack holes are square.

(i) NOTE: The screw hole at the front of the rail is behind the rail clamp.

NOTE: You need a long-handled screwdriver to reach the screw hole at the rear of the rack.

NOTE: The following figure does not show the C-clips that are used to attach the cable management arms.

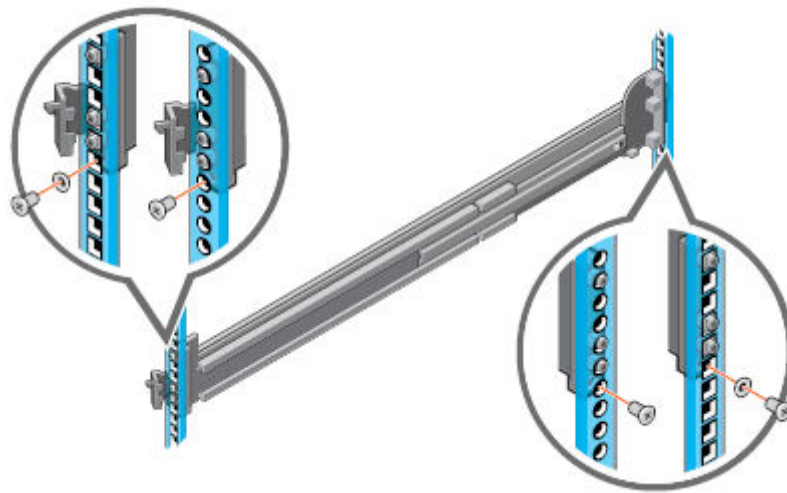

Figure 11. Adding the retaining screws

Install the system in the cabinet

In an angled drop-in design, inner (chassis) rails are attached to the sides of the system and then the system slides into the outer (cabinet) rails that are installed in the rack.

About this task

WARNING: The system is heavy. To avoid personal injury and/or damage to the equipment, do not attempt to install the system in a cabinet without a mechanical lift and/or help from another person.

Steps

1. Pull the inner rails out of the rack until they lock into place.
2. Release the inner rail lock by pulling forward on the orange tabs and sliding the inner rail out of the intermediate rails until they are fully extended.

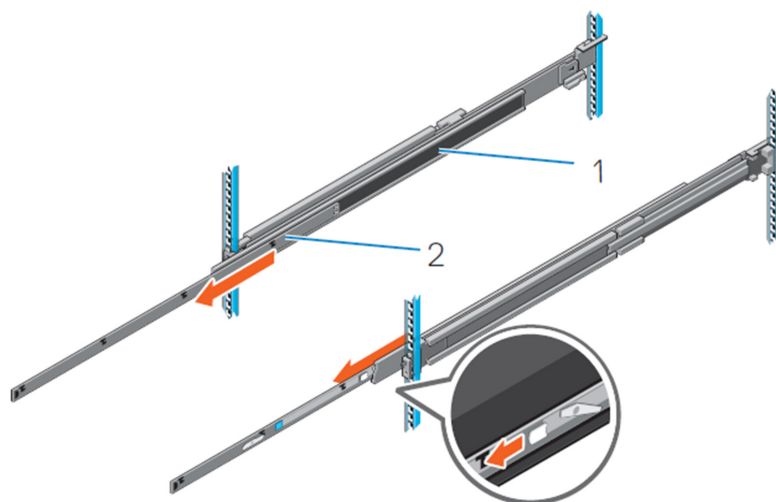

Figure 12. Pull out the intermediate rail

1. Intermediate rail
2. Inner rail
3. Attach the inner rails to the sides of the system by aligning the J-slots on the rail with the standoffs on the system and sliding forward on the system until they lock into place.

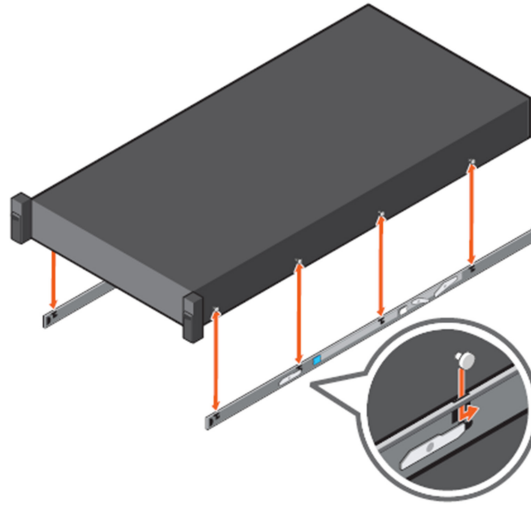

Figure 13. Attach the inner rails to the system

4. Verify all the J-slots on the rails are aligned with the rail standoffs on the system.

CAUTION: Improper installation on the rails may damage the rails or cause the system to fall when extended.

5. With the intermediate rails extended, install the system into the extended rails.

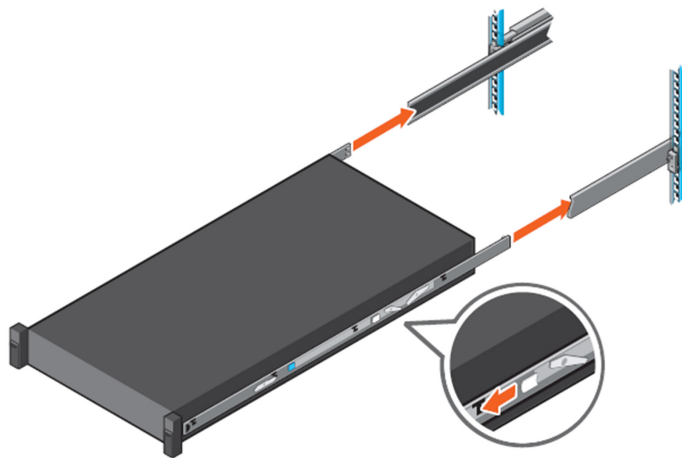

Figure 14. Install system into the extended rails

6. Pull the orange slide release lock tabs forward on both the rails, and slide the system into the rack.

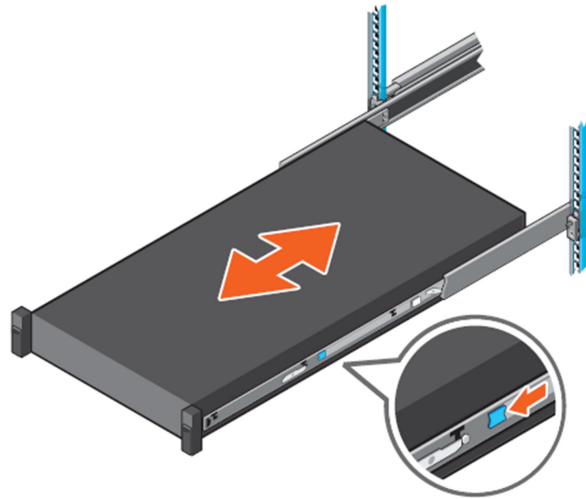

Figure 15. Slide system into the rack

Installing cable management arms

About this task

To properly orient the cable management arms, hold them with the silver side facing down. The words "Upper" and "Lower" on the arms should be legible.

Steps

1. Install the lower cable management arm:
 - a. On the right side of the rear of the cabinet, align the two retention latches with the two lower rail clips. Insert the retention latches into the clips until you feel and hear an audible click.
2. Install the upper cable management arm:
 - a. On the left side of the rear of the cabinet, align the two retention latches with the two upper rail clip. Insert the retention latches into the clips until you feel and hear an audible click.

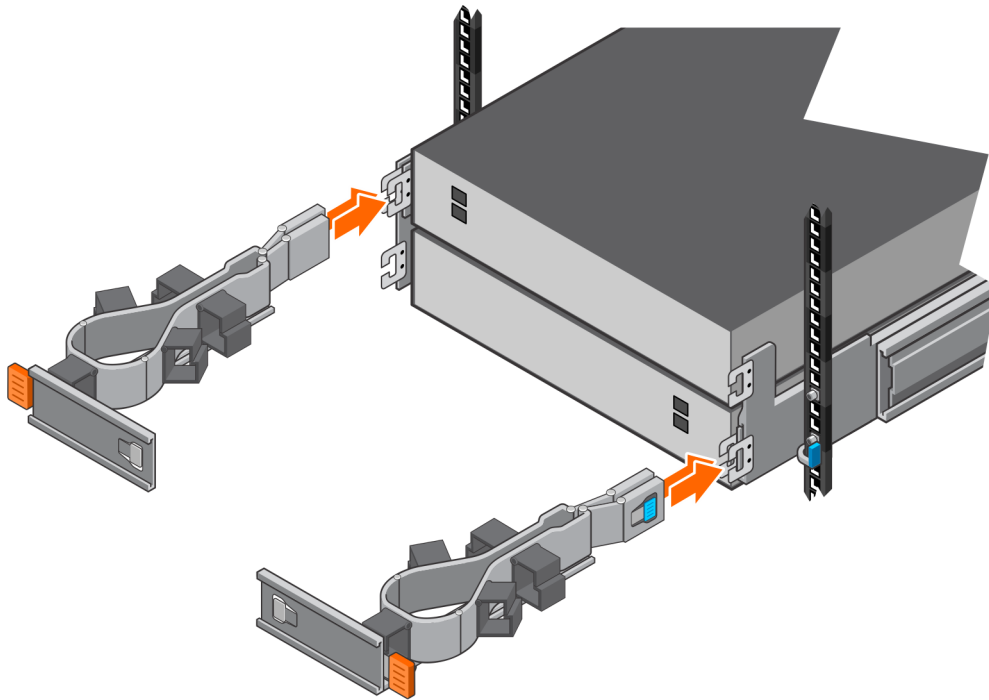

Figure 16. Installing the cable management arms

Cable the base enclosure to the NVMe expansion enclosure

Prerequisites

Determine how many expansion enclosures you are installing. Use the cable label diagrams that shipped with your system to determine the end-to-end locations for the back-end cables.

NOTE: Use QSFP28 to SFP28 cables to connect the base enclosure to the NVMe expansion enclosure. Use QSFP28 to QFSP28 cables to connect an NVMe expansion enclosure to another NVMe expansion enclosure.

Steps

1. Apply the provided cable labels to each end of the cables.

NOTE: The system ships with three sheets of labels. All three sheets contain the same information. They are just different colors. You only need to use one label sheet per expansion enclosure. The different colors are to identify which expansion enclosure the cables belong to. For example, you could use the pink label sheet for the first enclosure, and then use the green sheet for the second enclosure.

2. Ensure that the cable management arms (CMAs) are fully open and in the service position.
3. Open the CMA baskets and loosen the velcro straps.
4. Based on the following figures, route the data cables through the CMAs. The cables represented by yellow lines route through the upper CMA, and the cables represented by blue lines route through the lower CMA.

Follow these guidelines when routing cables:

- Gently route the cables into and around the arms without excess bending.
- Ensure that the data cables are oriented correctly to latch into the ports.
- There should not be any more slack between the expansion enclosure and the CMA than is needed to direct the cable. Any excess length should be outside of the CMA and dressed when cabling is complete.
- In two or three expansion enclosure configurations, route the data cables between the expansion enclosures through the CMA for one expansion enclosure and into the CMA of the other expansion enclosure.

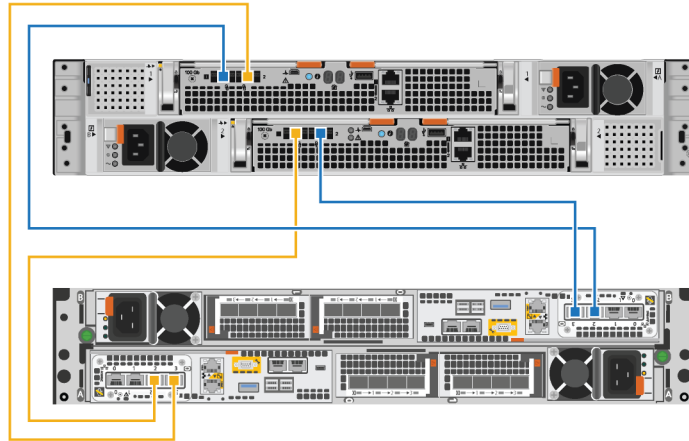

Figure 17. Cabling a single expansion enclosure

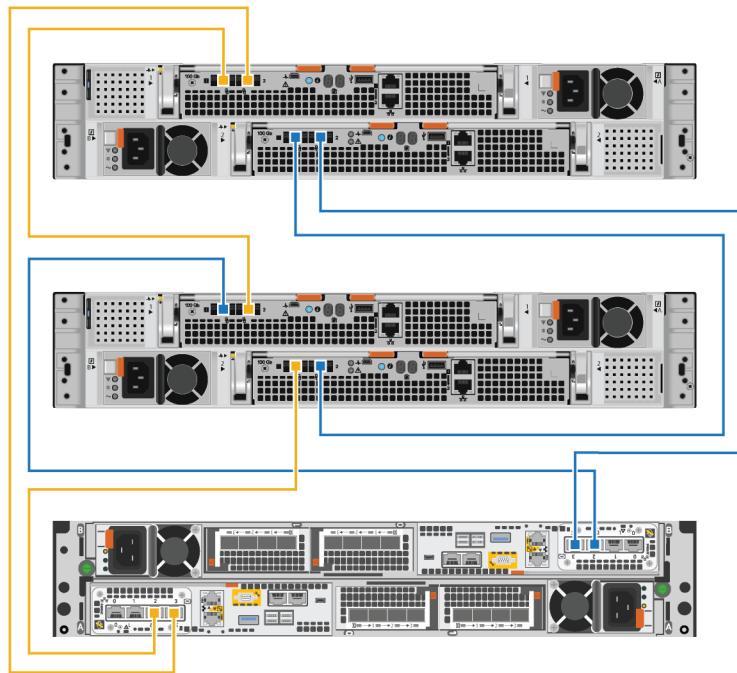

Figure 18. Cabling two expansion enclosures

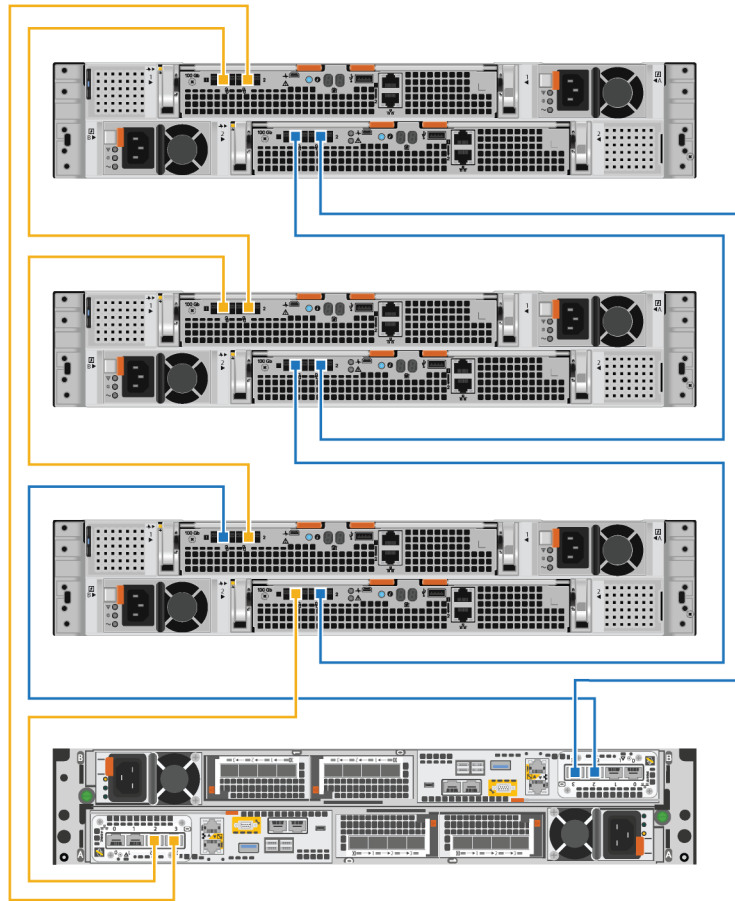

Figure 19. Cabling three expansion enclosures

5. Route the power cables through the CMAs. The power cables for power supplies on the left route through the upper CMA. The power cables for power supplies on the right route through the lower CMAs.
6. Plug each power cable into the expansion enclosure power supply and secure the cord with the retention bail at the connector.
 - i** **NOTE:** If the power source PDU is energized, do not connect the power cables to the PDU until the system is ready to be brought online. If you connect the power cables sooner, the system may power on during the installation.
 - i** **NOTE:** It is recommended that you plug in the black power cables on the left and the gray power cables on the right. The power cables work in either power supply, but a consistent cabling method makes it easier to troubleshoot issues.
7. Close all the baskets and tighten the Velcro on the arms to prevent the cables from slipping.

Closing the cable management arms

Steps

1. Close the lower cable management arm:
 - a. Swing the lower cable management arm to the left side of the enclosure, and align the retention latch with the lower rail bracket.
 - b. Press the retention latch onto the lower rail bracket.
 - c. Ensure that you hear the audible click that indicates that the lower cable management arm is in place.
2. Close the upper cable management arm:

- a. Swing the upper cable management arm to the right side of the enclosure, and align the retention latch with the upper rail bracket.
- b. Press the retention latch onto the upper rail bracket.
- c. Ensure that you hear the audible click that indicates that the upper cable management arm is in place.

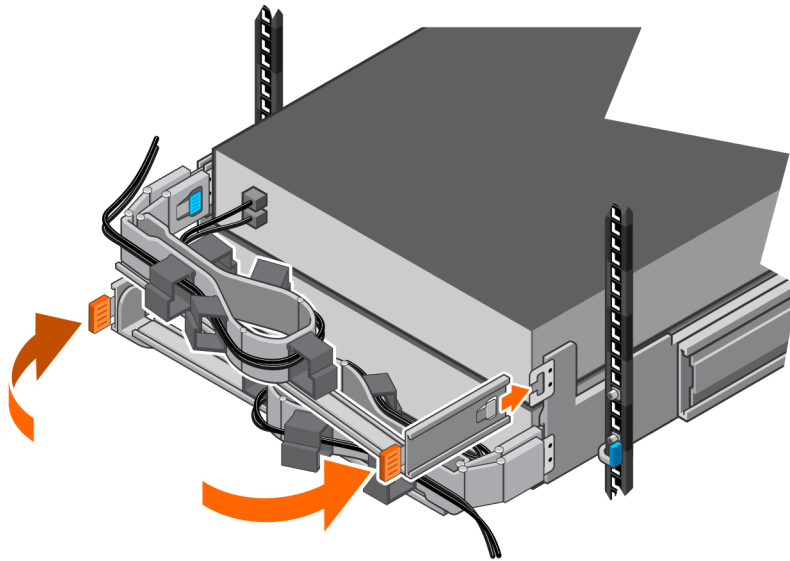

Figure 20. Closing the cable management arms

Testing the cable management arms

Steps

1. From the front of the rack, lift the black tabs on the expansion enclosure and slowly pull the expansion enclosure from the rack to ensure that proper slack has been provided for the cables.
2. Ensure that the stops on the rails engage into the service position when the top access door is clear.
3. If you feel resistance, stop pulling and adjust any tight cables so that pulling the expansion enclosure from the rack does not strain any cables or pull them from the ports.
4. Ensure that you can remove the expansion enclosure from the rack until it is in the service position. The expansion enclosure is in the service position when it clicks into place and will not move any further.
5. Once you have finished adjusting the cables, pull the orange tabs on the side of the expansion enclosure, and push the expansion enclosure back into the rack until it locks into place.
6. Inspect the cables again to make any necessary final adjustments.
7. Using a Philips screwdriver, tighten the chassis-securing screws located under the self-locking latches on the front of the expansion enclosure. These screws secure the expansion enclosure chassis to the cabinet rails in the event that the cabinet needs to be moved.

Installing drives

If the drives shipped separately from the enclosure, install them in the enclosure now. If the drives are already installed in the enclosure, you are ready to install the bezel.

Installing a drive

About this task

i **NOTE:** If you are installing multiple drives in a system that is powered up, wait at least 10 seconds before sliding the next drive into position, but do not exceed 2 minutes. This will allow the system to determine the best RAID width.

i **NOTE:** Drives must be installed from left-to-right starting with the first available slot.

Steps

1. Align the drive with the guides in the slot.
2. With the latch fully opened, gently push the drive into the slot.
The latch begins to rotate downward when it meets the enclosure.
3. Push the orange button until the drive is fully seated in the slot.
4. Push the latch down until it locks into place.

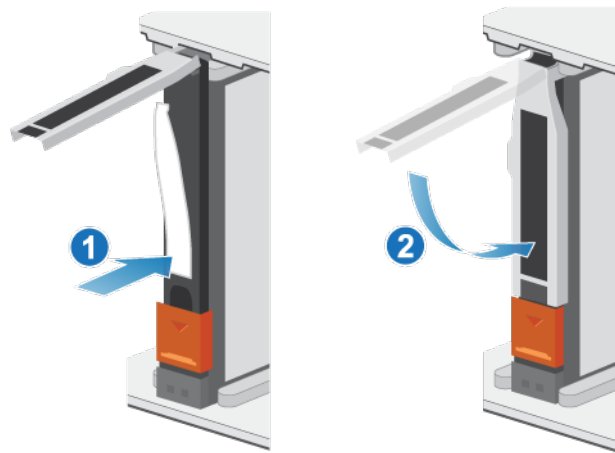

Figure 21. Installing a drive

The activity light flashes to indicate that the spin-up sequence has begun.

Installing the front bezel

Prerequisites

△ **CAUTION:** If the protective plastic strip is present on the front of the bezel, it must be removed before placing the system into operation. Failure to remove the protective plastic strip will cause the system to overheat.

About this task

Refer to [Installing the bezel](#) while performing the procedure that follows.

Steps

1. If present, remove the protective plastic strip from the front of the bezel.
2. Align the bezel with the enclosure.
3. Gently push the bezel into place on the cabinet until it latches.
4. If the bezel has a key lock, lock the bezel with the provided key.

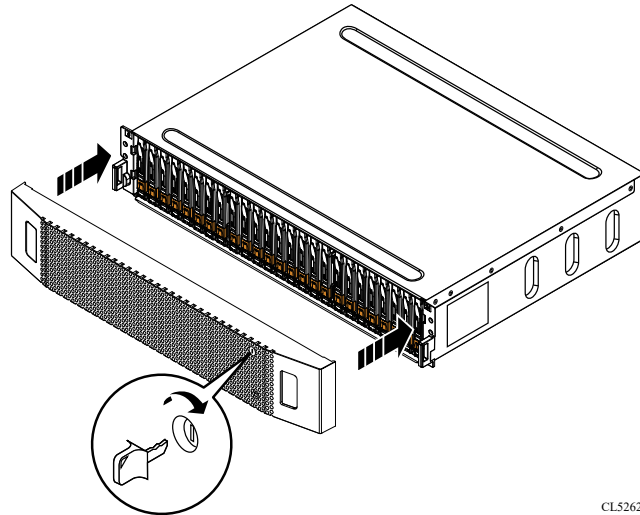

Figure 22. Installing the bezel

Add an NVMe expansion enclosure

Take the following actions to add an NVMe expansion enclosure to a running system with existing expansion enclosures.

NOTE: If this is the first NVMe expansion enclosure, refer to [Install an ENS24 expansion enclosure](#).

Summary of tasks for adding an expansion enclosure

To add an expansion enclosure to a running system, complete the tasks below in the order in which they appear. This document provides instructions for completing each task.

NOTE: When adding an expansion enclosure to a running system, you must power on the expansion enclosure before attaching the back-end cables.

1. Verify the contents of the shipping package.
2. Choose the space in the cabinet for the new expansion enclosure.
3. Remove the filler panels that cover the cabinet space for the new expansion enclosure.
4. Install the rails for the new expansion enclosure in the cabinet.
5. Install the expansion enclosure on the rails.
6. Install the cable management arms.
7. Apply cable labels.
8. Route the data cables and power cords through the cable management arms.
9. Attach the power cables to the new expansion enclosure.
10. Close the cable management arms.
11. Test the cable management arms.
12. Plug the power cables into the power source.
13. Attach the expansion (back-end) cables to the new expansion enclosure.
14. If the new expansion enclosure shipped without its drives installed, install the drives in the expansion enclosure.
15. Install the front bezel on the new expansion enclosure.

Verify shipping package contents

Confirm that you received all the equipment that is required to install the new NVMe expansion enclosure.

Table 5. Shipping package contents



Component		Quantity
NVMe expansion enclosure		1
Rail kit, including Snap-in rails (2) Screws (2 per rail)		1
Cable management arms		2
Power cords, either Black and gray C13/C14 Black and gray C13/C20		2
Bezel for NVMe expansion enclosure (with key)		1

Table 5. Shipping package contents (continued)

Component		Quantity
<p>100G QSFP28 cables to connect the base enclosure to the NVMe expansion enclosure, the NVMe expansion enclosure to another NVMe expansion enclosure, and to loopback from the NVMe expansion enclosure to the base enclosure.</p> <p>NOTE: The first NVMe expansion enclosure ships with four 100G QSFP28 cables. The second and third NVMe expansion enclosure ship with two 100G QSFP28 cables.</p>		2

Choose where to install the expansion enclosure

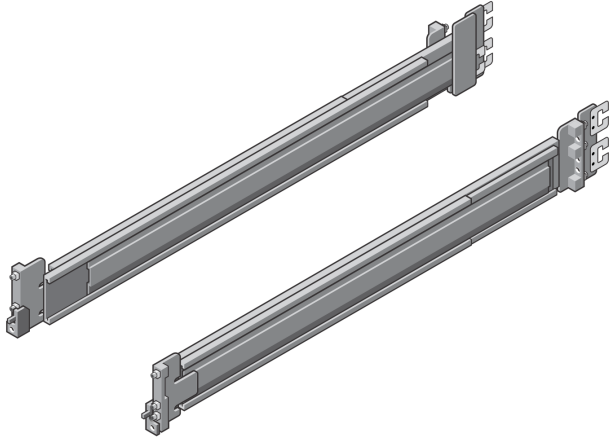
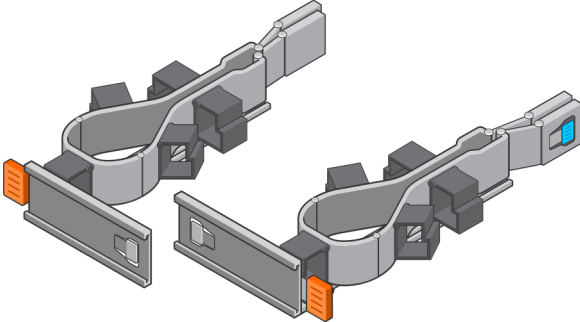
Before installing the new expansion enclosure, you should determine the placement of the new expansion enclosure within the rack.

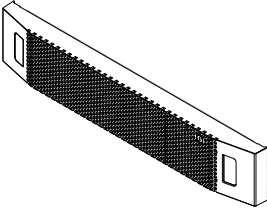
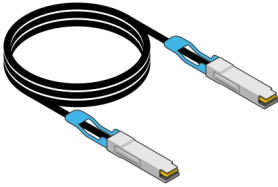
Steps

1. It is recommended that you install the expansion enclosure in the next available 2U space directly above the base enclosure or the last expansion enclosure in the system.
Most cabinets mark 1U increments with horizontal lines or small holes in the channels.
2. Considering these recommendations, choose a 2U space in the cabinet for the expansion enclosure.

Removing a filler panel

About this task

In most cases, the front space into which you will install the enclosure is covered by a filler panel.

Steps

If one or more filler panels cover the space where you want to install the enclosure, remove each panel.

Installing the NVMe expansion enclosure rails

About this task

Install the rails from the front of the cabinet into which you are installing the enclosure. The 2U NVMe expansion enclosure includes rails that slide into the cabinet rail assembly. The rails are dedicated left and right, and cannot be interchanged. The front side of each rail is labeled Left Front or Right Front.

Steps

1. Locate the 2U cabinet space designated for the enclosure.
2. Install the right rail to the rear NEMA channel.
 - a. Align the right rail with the lower U of the allotted 2U space.

- b. Push the rail back to secure the rail posts in the cabinet NEMA channel. An audible click indicates that the rail is secure in the channel.
- 3. Install the right rail to the front NEMA channel.
 - a. Align the front of the right rail so that it is level.
 - b. Pull the rail forward while holding the rail clamp open.
 - c. Once the rail posts are in the cabinet NEMA channel, release the rail clamp. An audible click indicates that the connection is secure.
- 4. Install the left rail by mirroring steps 2 and 3.

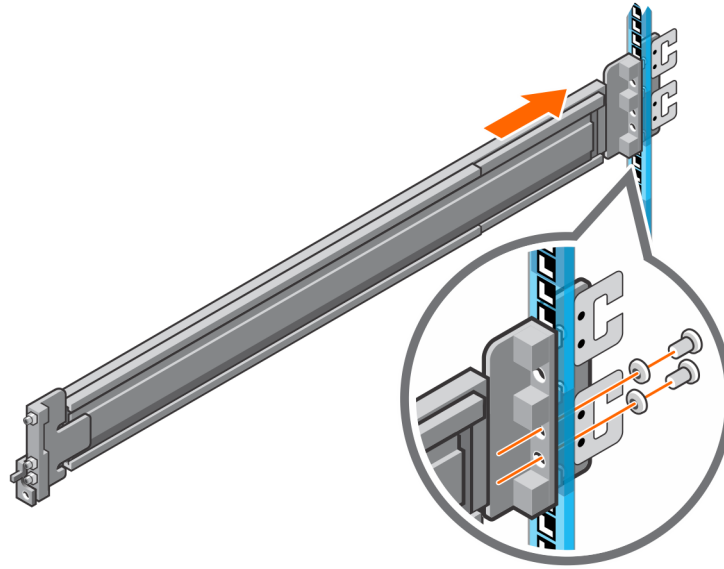

Figure 23. Installing the NVMe expansion enclosure rails (rear)

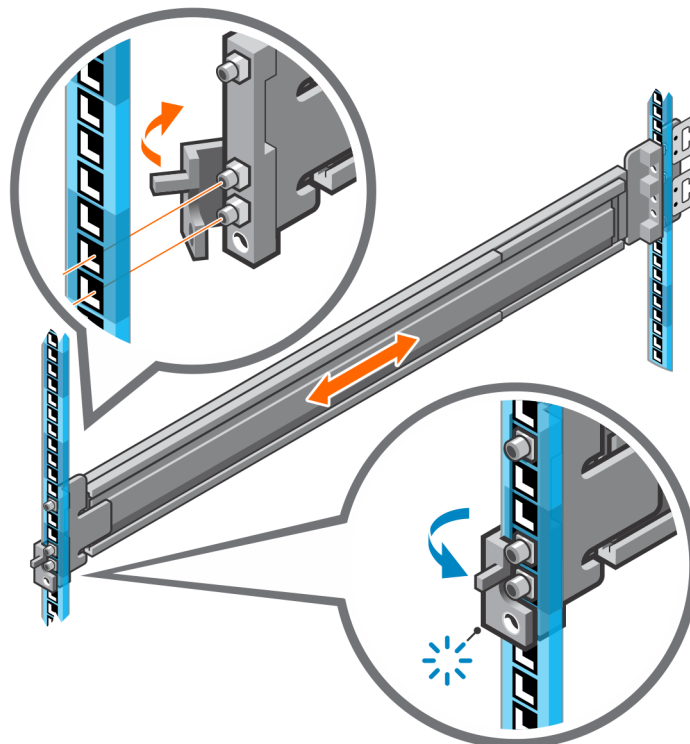

Figure 24. Installing the NVMe expansion enclosure rails (front)

5. Add the retaining screws that came with the rails to the front and back of both rails.

i **NOTE:** Use the washers that came with the rails if the rack holes are square.

i **NOTE:** The screw hole at the front of the rail is behind the rail clamp.

i **NOTE:** You need a long-handled screwdriver to reach the screw hole at the rear of the rack.

i **NOTE:** The following figure does not show the C-clips that are used to attach the cable management arms.

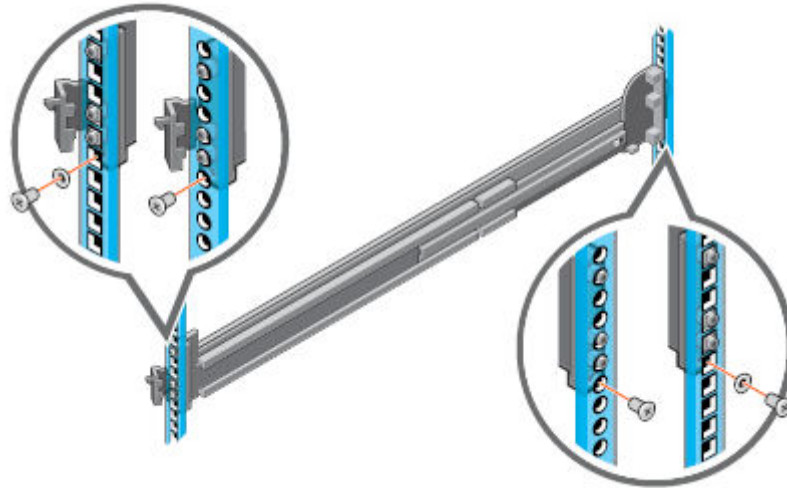

Figure 25. Adding the retaining screws

Install the system in the cabinet

In an angled drop-in design, inner (chassis) rails are attached to the sides of the system and then the system slides into the outer (cabinet) rails that are installed in the rack.

About this task

⚠ **WARNING:** The system is heavy. To avoid personal injury and/or damage to the equipment, do not attempt to install the system in a cabinet without a mechanical lift and/or help from another person.

Steps

1. Pull the inner rails out of the rack until they lock into place.
2. Release the inner rail lock by pulling forward on the orange tabs and sliding the inner rail out of the intermediate rails until they are fully extended.

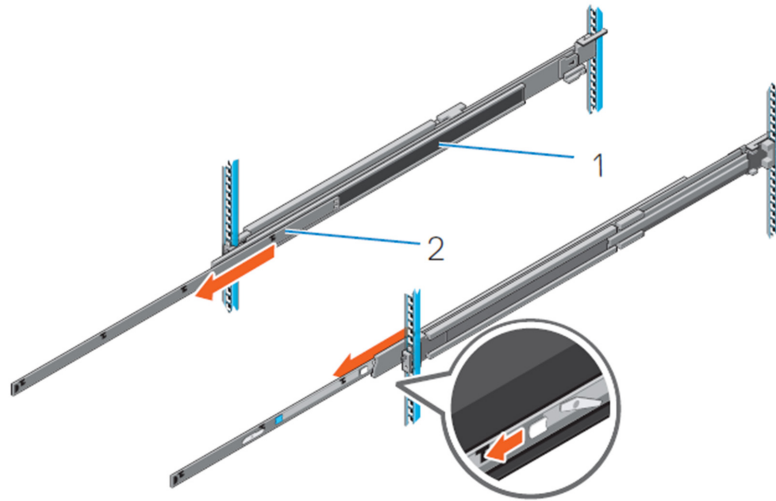

Figure 26. Pull out the intermediate rail

1. Intermediate rail
 2. Inner rail
3. Attach the inner rails to the sides of the system by aligning the J-slots on the rail with the standoffs on the system and sliding forward on the system until they lock into place.

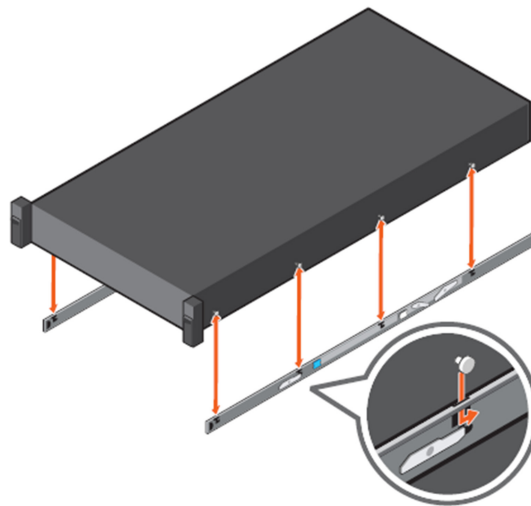

Figure 27. Attach the inner rails to the system

4. Verify all the J-slots on the rails are aligned with the rail standoffs on the system.
- ⚠ CAUTION: Improper installation on the rails may damage the rails or cause the system to fall when extended.**
5. With the intermediate rails extended, install the system into the extended rails.

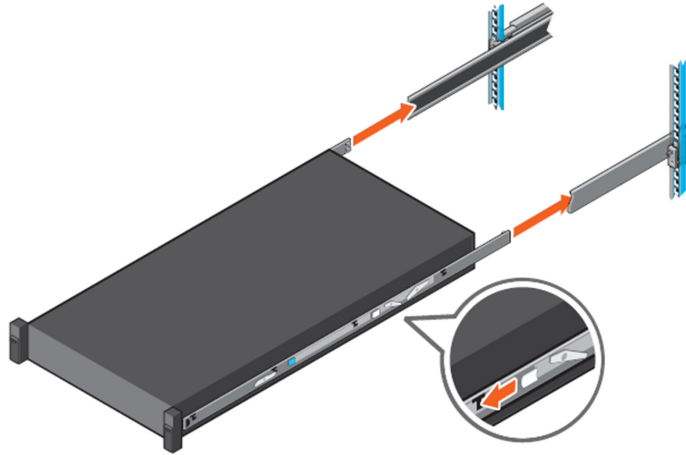

Figure 28. Install system into the extended rails

6. Pull the orange slide release lock tabs forward on both the rails, and slide the system into the rack.

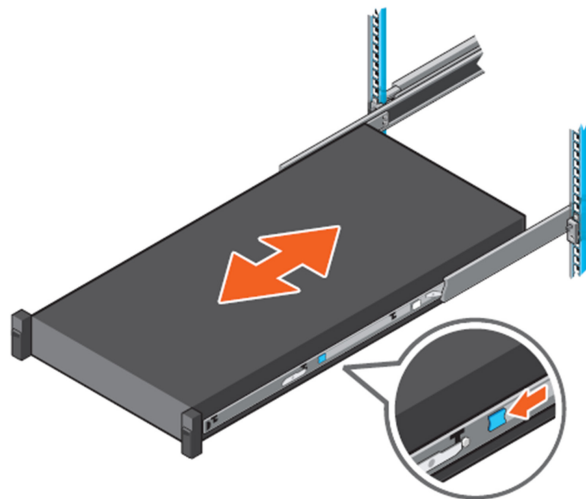

Figure 29. Slide system into the rack

Installing cable management arms

About this task

To properly orient the cable management arms, hold them with the silver side facing down. The words "Upper" and "Lower" on the arms should be legible.

Steps

1. Install the lower cable management arm:
 - a. On the right side of the rear of the cabinet, align the two retention latches with the two lower rail clips. Insert the retention latches into the clips until you feel and hear an audible click.
2. Install the upper cable management arm:
 - a. On the left side of the rear of the cabinet, align the two retention latches with the two upper rail clip. Insert the retention latches into the clips until you feel and hear an audible click.

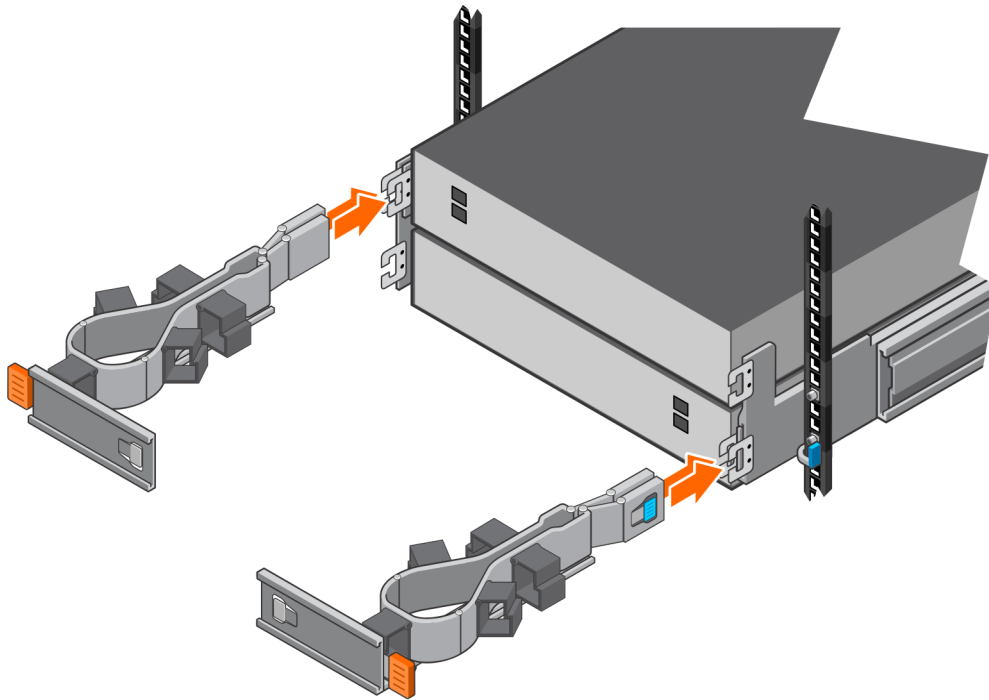

Figure 30. Installing the cable management arms

Cable the new NVMe expansion enclosure

Follow these guidelines to cable an expansion enclosure in a running system to a new expansion enclosure.

Prerequisites

Apply cable labels to the cables connecting the expansion enclosures. "Last expansion enclosure" refers to the last expansion enclosure that is currently installed. The "new expansion enclosure" refers to the expansion enclosure that you are adding.

CAUTION: Incorrect cabling could cause all new drives to be locked.

NOTE: Do not plug any cables into the RJ45 ports.

About this task

Route the data cables through the cable management arms, but do not connect them to the ports yet. Ensure that there is enough slack for each cable to connect to the designated port.

Steps

1. Move the two loopback cables from port 2 of the last expansion enclosure to port 2 of the new expansion enclosure:
 - a. Disconnect the QSFP cable from LCC 1, port 2 of the last expansion enclosure and move it to LCC 1, port 2 of the new expansion enclosure.
 - b. Disconnect the QSFP cable from LCC 2, port 2 of the last expansion enclosure and move it to LCC 2, port 2 of the new expansion enclosure.
2. Add two new cables from port 2 of the last expansion enclosure to port 1 of the new expansion enclosure:
 - a. Use a new QSFP cable to connect LCC 1, port 2 of the last expansion enclosure to LCC 1, port 1 of the new expansion enclosure.
 - b. Use a new QSFP cable to connect LCC 2, port 2 of the last expansion enclosure to LCC 2, port 1 of the new expansion enclosure.

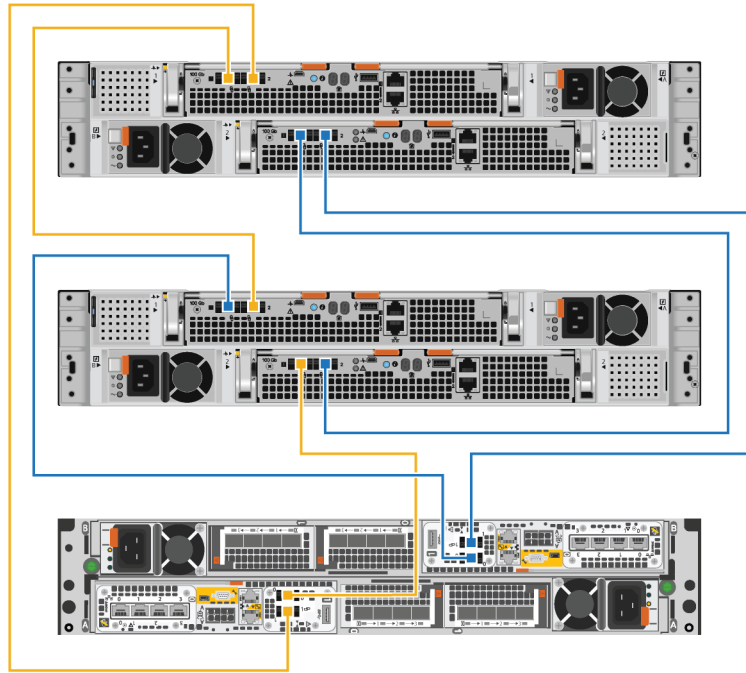

Figure 31. Cabling two expansion enclosures

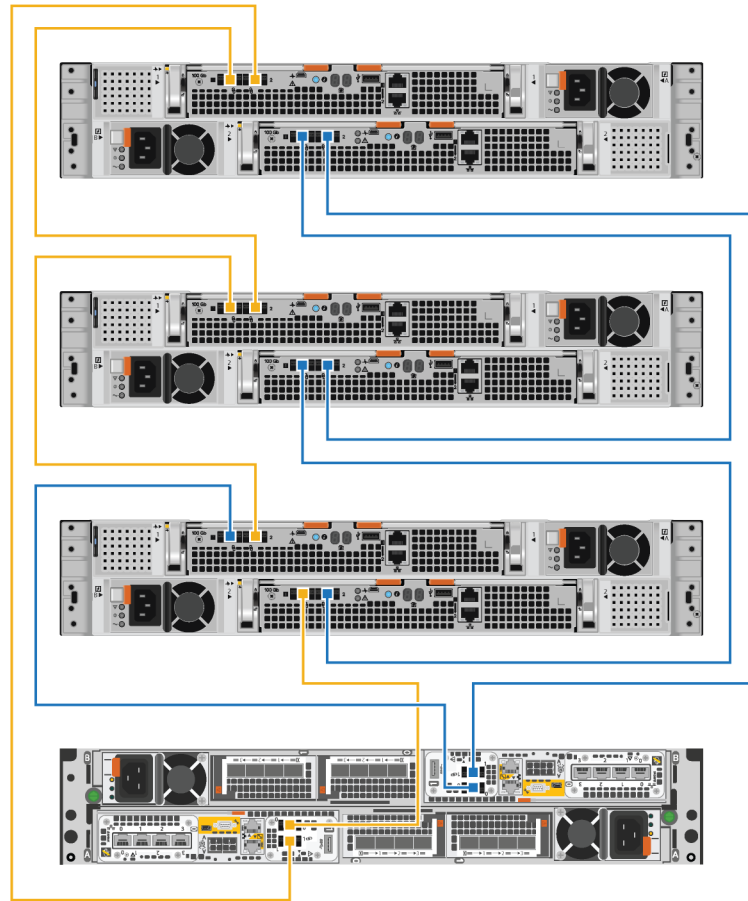

Figure 32. Cabling three expansion enclosures

3. Route the power cables through the cable management arms. The power cables for power supplies on the left route through the upper cable management arms. The power cables for power supplies on the right route through the lower cable management arms.
4. Plug each power cable into the expansion enclosure power supply and secure the cord with the retention bail at the connector.
 - i** **NOTE:** If the power source PDU is energized, do not connect the power cables to the PDU until the system is ready to be brought online. If you connect the power cables sooner, the system may power on during the installation.
 - i** **NOTE:** It is recommended to plug in the black power cables on the left and the gray power cables on the right. The power cables work in either power supply, but a consistent cabling method makes it easier to troubleshoot issues.

Closing the cable management arms

Steps

1. Close the lower cable management arm:
 - a. Swing the lower cable management arm to the left side of the enclosure, and align the retention latch with the lower rail bracket.
 - b. Press the retention latch onto the lower rail bracket.
 - c. Ensure that you hear the audible click that indicates that the lower cable management arm is in place.
2. Close the upper cable management arm:
 - a. Swing the upper cable management arm to the right side of the enclosure, and align the retention latch with the upper rail bracket.

- b. Press the retention latch onto the upper rail bracket.
- c. Ensure that you hear the audible click that indicates that the upper cable management arm is in place.

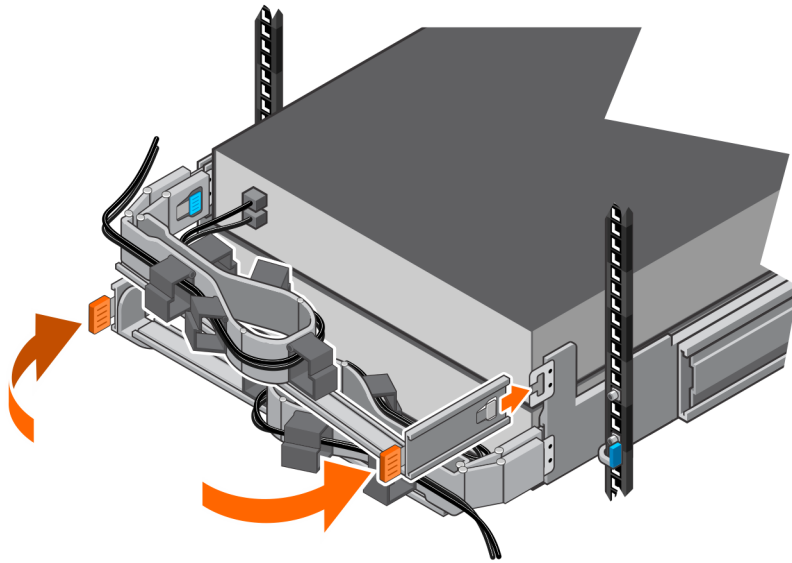

Figure 33. Closing the cable management arms

Testing the cable management arms

Steps

1. From the front of the rack, lift the black tabs on the expansion enclosure and slowly pull the expansion enclosure from the rack to ensure that proper slack has been provided for the cables.
2. Ensure that the stops on the rails engage into the service position when the top access door is clear.
3. If you feel resistance, stop pulling and adjust any tight cables so that pulling the expansion enclosure from the rack does not strain any cables or pull them from the ports.
4. Ensure that you can remove the expansion enclosure from the rack until it is in the service position. The expansion enclosure is in the service position when it clicks into place and will not move any further.
5. Once you have finished adjusting the cables, pull the orange tabs on the side of the expansion enclosure, and push the expansion enclosure back into the rack until it locks into place.
6. Inspect the cables again to make any necessary final adjustments.
7. Using a Philips screwdriver, tighten the chassis-securing screws located under the self-locking latches on the front of the expansion enclosure. These screws secure the expansion enclosure chassis to the cabinet rails in the event that the cabinet needs to be moved.

Attach the cables

Steps

1. Plug the power cables into the power source.
2. Attach the data cables to the ports on the new expansion enclosure.

Installing drives

If the drives shipped separately from the enclosure, install them in the enclosure now. If the drives are already installed in the enclosure, you are ready to install the bezel.

Installing a drive

About this task

i **NOTE:** If you are installing multiple drives in a system that is powered up, wait at least 10 seconds before sliding the next drive into position, but do not exceed 2 minutes. This will allow the system to determine the best RAID width.

i **NOTE:** Drives must be installed from left-to-right starting with the first available slot.

Steps

1. Align the drive with the guides in the slot.
2. With the latch fully opened, gently push the drive into the slot.
The latch begins to rotate downward when it meets the enclosure.
3. Push the orange button until the drive is fully seated in the slot.
4. Push the latch down until it locks into place.

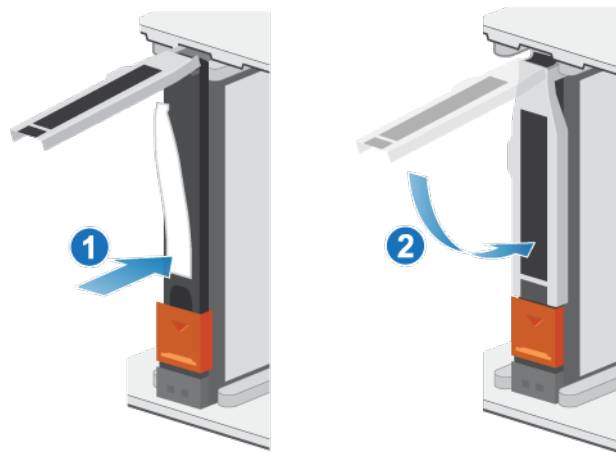

Figure 34. Installing a drive

The activity light flashes to indicate that the spin-up sequence has begun.

Installing the front bezel

Prerequisites

△ **CAUTION:** If the protective plastic strip is present on the front of the bezel, it must be removed before placing the system into operation. Failure to remove the protective plastic strip will cause the system to overheat.

About this task

Refer to [Installing the bezel](#) while performing the procedure that follows.

Steps

1. If present, remove the protective plastic strip from the front of the bezel.
2. Align the bezel with the enclosure.
3. Gently push the bezel into place on the cabinet until it latches.
4. If the bezel has a key lock, lock the bezel with the provided key.

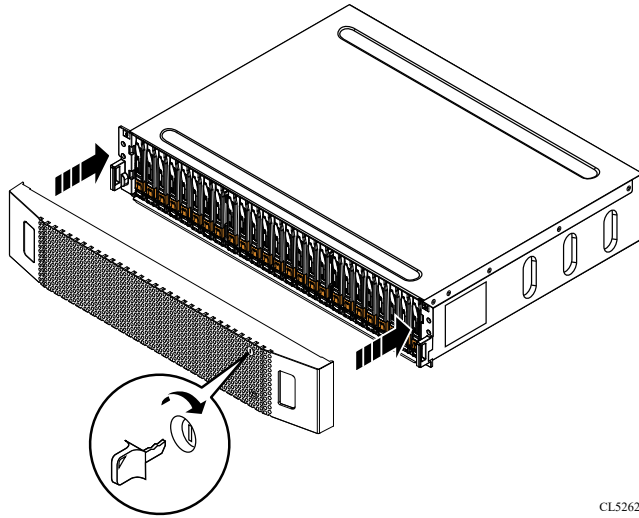

CL5262

Figure 35. Installing the bezel

Base enclosure service procedures

The base enclosure contains customer-replaceable components. Follow these procedures to safely replace a failed component.

 **NOTE:** Review the information in [Safety precautions for handling replaceable units](#) before handling replaceable parts.

Topics:

- [Replace a faulted drive in the base enclosure](#)
- [Add a new drive to the base enclosure](#)
- [Replace an AC power supply](#)
- [Replace a DC power supply](#)
- [Replace a 4-port card](#)
- [Replace an SFP](#)
- [Replace an I/O module](#)
- [Replace a fan module](#)
- [Replace a dual inline memory module \(DIMM\)](#)
- [Replace an internal M.2 boot module](#)

Replace a faulted drive in the base enclosure

Take the following actions to remove a faulted drive and install the replacement drive into the base enclosure.

 **NOTE:** If you are proactively replacing multiple drives, use the Proactive Drive Replacement procedure available in SolVe.

Identify a faulted drive from PowerStore Manager

Before you replace a drive, ensure that you have identified its location within the system. Using PowerStore Manager, you can identify and locate a faulted drive.

Steps

1. From PowerStore Manager, select **Hardware** > **Appliances**.
2. Select the appliance that includes the drive that you need to replace.
3. On the **Components** card, under **Drives**, expand **BaseEnclosure** and select the faulted drive.
Faulted parts appear in red in the image of the system, and report a status of `Failed` in the **State** field.
4. Click **Blink LED**.
The amber fault light on the drive starts blinking.

Remove a faulted 2.5" drive

Steps

1. Check PowerStore Manager to ensure that it is not displaying an event banner indicating that drives should not be removed.
2. Locate the drive with the blinking amber LED fault light.
3. Push down the orange button to release the latch.
4. Remove the drive from the slot.

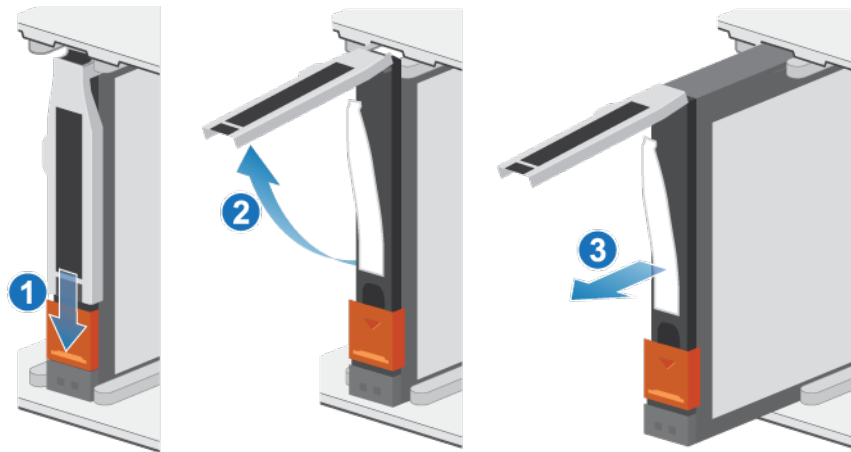

Figure 36. Removing a 2.5" drive

5. Place the drive on a static-free surface.

Install a 2.5" drive

Steps

1. Align the drive with the guides in the slot.
2. With the latch fully opened, gently push the drive into the slot.
The latch begins to rotate downward when it meets the enclosure.
3. Push the orange button until the drive is fully seated in the slot.
4. Push the latch down until it locks into place.

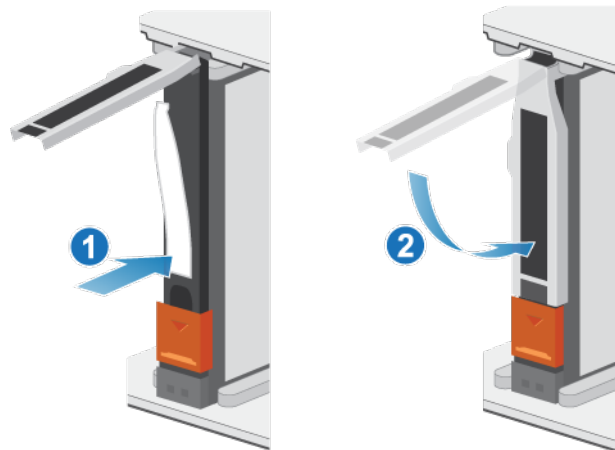

Figure 37. Installing a 2.5" drive

The activity light flashes to indicate that the spin-up sequence has begun.

Verify the operation of a replacement drive

Steps

1. From PowerStore Manager, select **Hardware > Appliances**.
2. Select the appliance where you replaced the drive.
3. On the **Components** card, under **Drives**, expand **BaseEnclosure** and select the drive.

The status of the replacement drive should read `Healthy`. If the status is still `Faulted`, wait a few minutes and refresh PowerStore Manager. If the status does not change, ensure that the drive is correctly seated, or contact your service provider.

4. Click **Stop Blink LED**.

Return a faulted part

About this task

For US customers, return defective material within five business days. For International customers, return defective material within 10 business days. The materials required to return your defective part are supplied with the good part shipment.

Steps

1. Package the faulted part in the shipping box that contained the replacement part.
2. Ship the failed part to your service provider as described in the instructions that were included with the replacement part.
3. For more information about returning customer-replaceable parts:
 - a. Open PowerStore Manager.
 - b. Click **Settings** on the upper right of the screen.
 - c. Click **General Support**.
 - d. Under **Drives, Power Supplies, and Other Parts**, click **Return Part**.
 - e. If your screen does not show the Return Part link, contact your service provider for instructions.

Add a new drive to the base enclosure

Take the following actions to add a new drive to the base enclosure.

 **CAUTION: Do not add drives to powered off systems. For details, see Dell knowledge base article 000187118.**

Removing the front bezel

Steps

1. If the bezel has a lock, insert the key that shipped with your enclosure into the lock, and turn the key to unlock the bezel.
2. Press the two latch buttons on the bezel surface to release the bezel from the cabinet.
3. Pull the bezel off the cabinet and put it on a clean, static-free surface.

Remove a drive filler module

Steps

1. Insert your finger into the cutout on the drive filler module.
2. Pull the filler module out of the slot.

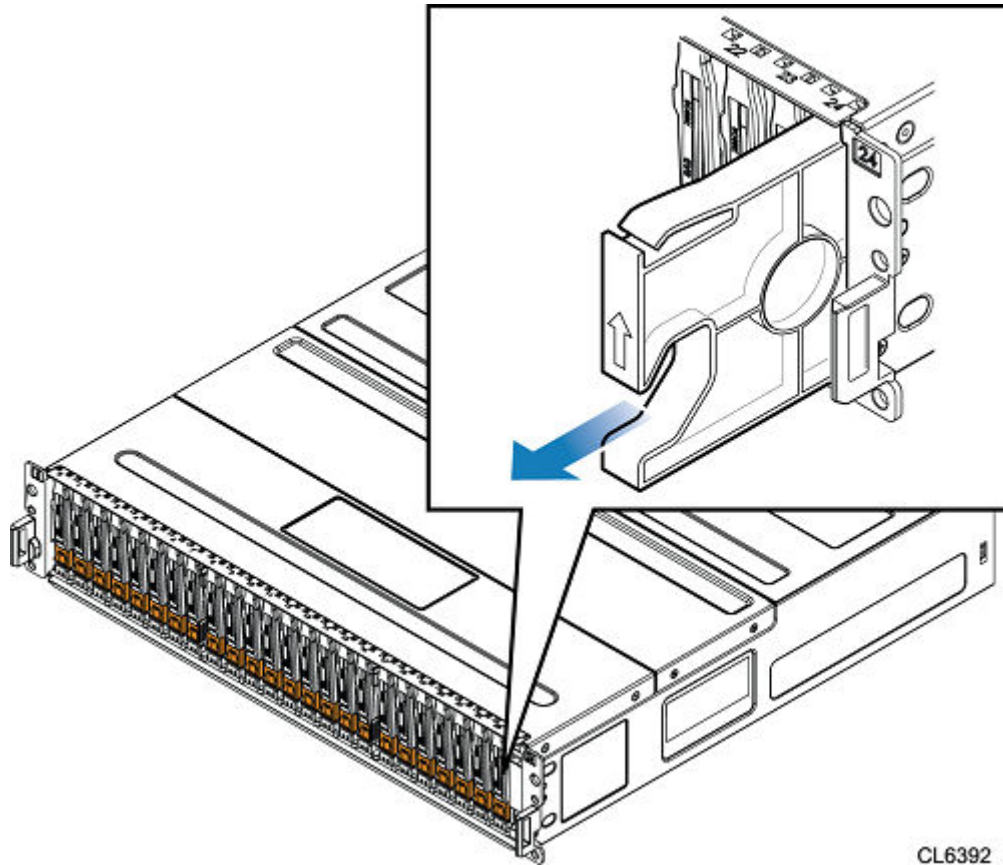

CL6392

Figure 38. Removing a drive filler module

Install a 2.5" drive

About this task

NOTE: If you are installing multiple drives in a system that is powered up, wait at least 10 seconds before sliding the next drive into position, but do not exceed 2 minutes. This will allow the system to determine the best RAID width.

NOTE: Drives must be installed from left-to-right starting with the first available slot.

Steps

1. Align the drive with the guides in the slot.
2. With the latch fully opened, gently push the drive into the slot.
The latch begins to rotate downward when it meets the enclosure.
3. Push the orange button until the drive is fully seated in the slot.
4. Push the latch down until it locks into place.

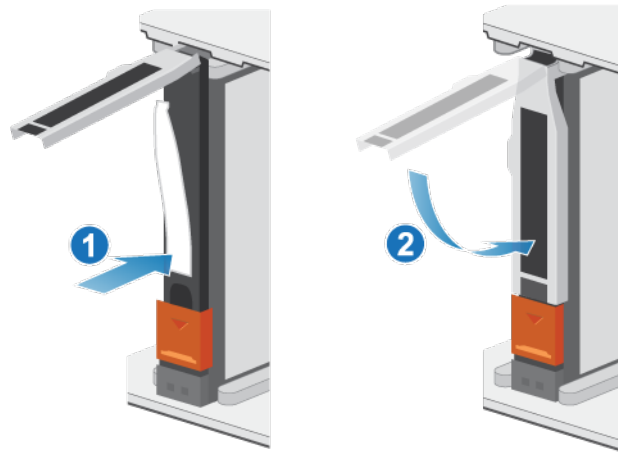

Figure 39. Installing a 2.5" drive

The activity light flashes to indicate that the spin-up sequence has begun.

Verify the operation of an added drive

Steps

1. From PowerStore Manager, select **Hardware > Appliances**.
2. Select the appliance where you added the drive.
3. On the **Components** card, under **Drives**, expand **BaseEnclosure** and select the drive.
The status of the drive should read `Healthy`. If the status is still `Failed`, wait a few minutes and refresh PowerStore Manager. If the status does not change, ensure that the drive is correctly seated, or contact your service provider.

Replace an AC power supply

Take the following actions to remove the faulted power supply and install the replacement power supply into the system.

Identify a faulted power supply from PowerStore Manager

Before you replace a power supply, ensure that you have identified its location within the system. Using PowerStore Manager, you can identify and locate a faulted power supply.

Steps

1. From PowerStore Manager, select **Hardware > Appliances**.
2. Select the appliance that includes the power supply that you need to replace.
3. On the **Components** card, under **Rear View**, expand **BaseEnclosure**.
4. Expand the node that includes the power supply, and then select **PSU0**.
Faulted parts appear in red in the image of the system, and report a status of `Failed` in the **State** field.

Base enclosure AC power supply

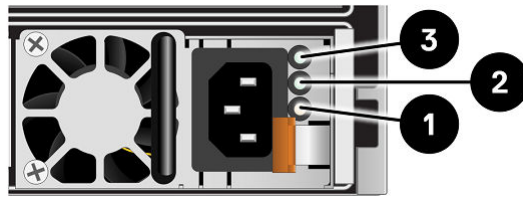

Figure 40. Base enclosure AC power supply LEDs

Table 6. Base enclosure AC power supply LEDs

LED	Location	State	Description
Fault	1	Solid amber	Power supply or backup fault. Check the cable connection.
		Off	No fault.
Supply output status	2	Green	Outputs are normal.
		Off	Outputs are faulted or disabled.
AC power (input)	3	Green	AC power is on.
		Off	AC power is off. Verify the source power.

Remove a power supply

About this task

There are two power supplies. The power supplies are installed in the top and bottom nodes, and the top power supply is installed upside-down. This procedure works for removing either power supply, however, the direction in which the retention bail and release handle are pressed is reversed for the upside-down power supply.

NOTE: You do not need to power off the system to remove a power supply.

Steps

1. Rotate the power cable retention bail to the left (to the right for the upside-down power supply). Remove the power cable from the power supply.

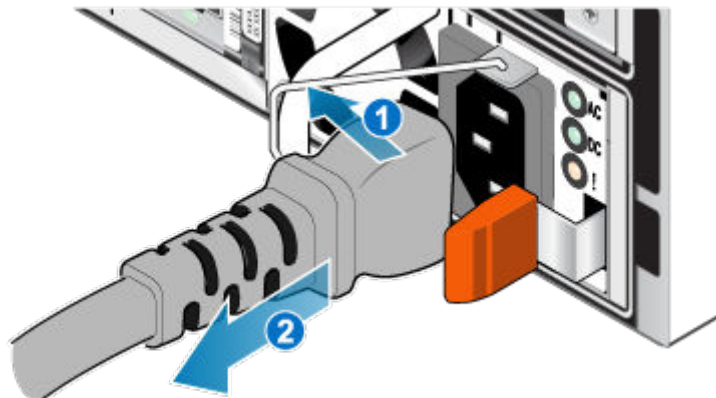

Figure 41. Removing the power cable

2. Push and hold the orange release tab to the left (to the right for the upside-down power supply) and grasp the power supply by its handle. Remove the power supply by pulling it from the node.

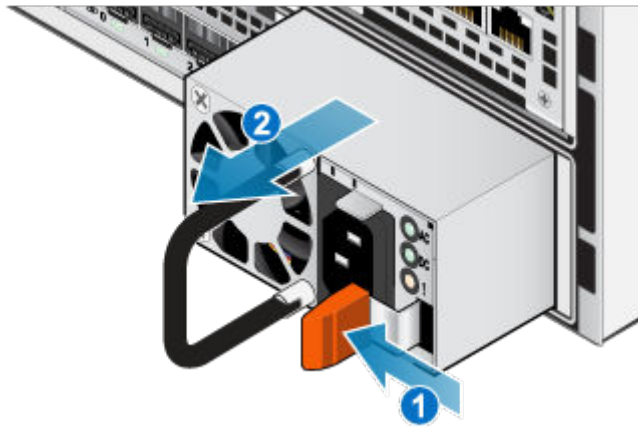

Figure 42. Removing a power supply

Install a power supply

About this task

The power supplies are installed in the top and bottom nodes, meaning that the top power supply is installed upside-down. This procedure works for installing either power supply.

Steps

1. Align the power supply with the slot in the node.
2. Push the power supply into the node until it clicks into place.

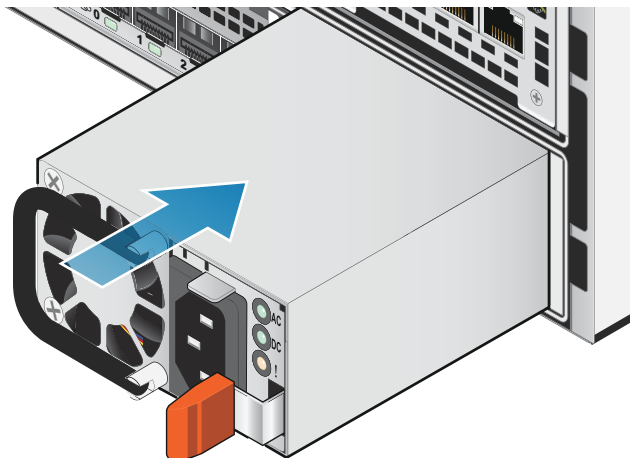

Figure 43. Installing a power supply

3. Connect the power cable to the power supply and secure the cord with the retention bail at the connector.

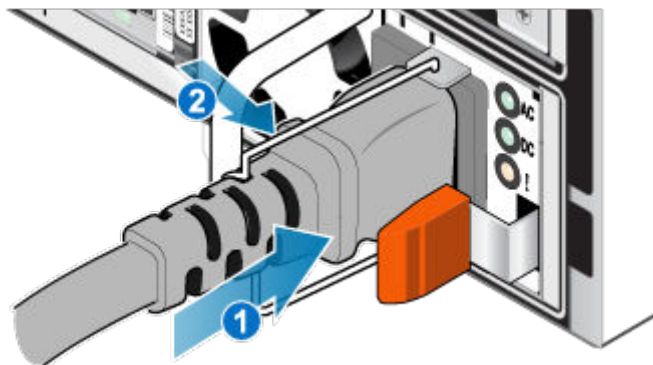

Figure 44. Inserting the power cable

Verify the operation of a replacement power supply

Steps

1. From PowerStore Manager, select **Hardware**.
2. Select the appliance where you replaced the power supply.
3. On the **Components** card, under **Rear View**, expand **BaseEnclosure**.
4. Expand the node that includes the power supply, and then select **PSU0**.

The status of the replacement power supply should read `Healthy`. If the status is still `Failed`, wait a few minutes and refresh PowerStore Manager. If the status does not change, ensure that the power supply is correctly seated, or contact your service provider.

Return a faulted part

About this task

For US customers, return defective material within five business days. For International customers, return defective material within 10 business days. The materials required to return your defective part are supplied with the good part shipment.

Steps

1. Package the faulted part in the shipping box that contained the replacement part.
2. Ship the failed part to your service provider as described in the instructions that were included with the replacement part.
3. For more information about returning customer-replaceable parts:
 - a. Open PowerStore Manager.
 - b. Click **Settings** on the upper right of the screen.
 - c. Click **General Support**.
 - d. Under **Drives, Power Supplies, and Other Parts**, click **Return Part**.
 - e. If your screen does not show the Return Part link, contact your service provider for instructions.

Replace a DC power supply

Take the following actions to remove the faulted power supply and install the replacement power supply into the system.

Identify a faulted power supply from PowerStore Manager

Before you replace a power supply, ensure that you have identified its location within the system. Using PowerStore Manager, you can identify and locate a faulted power supply.

Steps

1. From PowerStore Manager, select **Hardware > Appliances**.
2. Select the appliance that includes the power supply that you need to replace.
3. On the **Components** card, under **Rear View**, expand **BaseEnclosure**.
4. Expand the node that includes the power supply, and then select **PSU0**.
Faulted parts appear in red in the image of the system, and report a status of `Failed` in the **State** field.

Base enclosure DC power supply

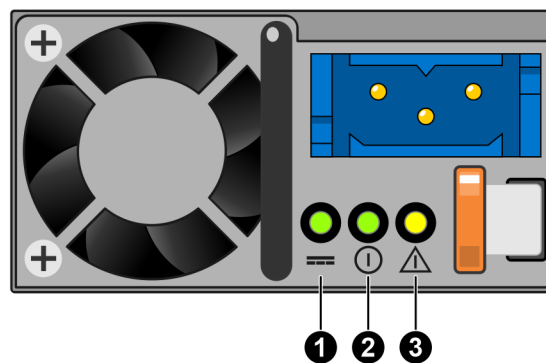

Figure 45. Base enclosure DC power supply LEDs

Table 7. Base enclosure DC power supply LEDs

LED	Location	State	Description
DC power (input)	1	Green	DC power is on.
		Off	DC power is off. Verify the source power.
DC power (output)	2	Green	The power supply is operating normally.
		Off	The power supply is not operating properly.
Fault	3	Amber	Power supply fault. Check the cable connection.
		Amber blinking	Over temperature fault.
		Off	No fault.

Remove a DC power supply

About this task

There are two power supplies. The power supplies are installed in the top and bottom nodes, and the top power supply is installed upside-down. This procedure works for removing either power supply, however, the direction in which the release handle is pressed is reversed for the upside-down power supply.

NOTE: You do not need to power off the system to remove a power supply.

Steps

1. Remove the power cable from the power supply.

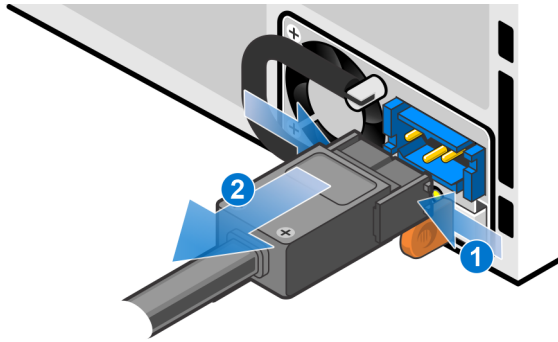

Figure 46. Removing a DC power cable

2. Push and hold the orange release tab to the left (to the right for the upside-down power supply) and grasp the power supply by its handle. Remove the power supply by pulling it from the node.

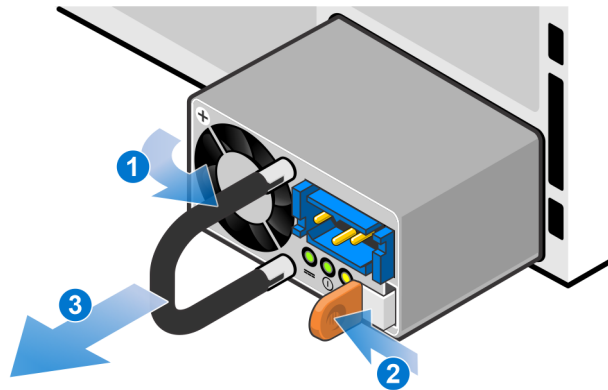

Figure 47. Removing a DC power supply

Install a DC power supply

About this task

The power supplies are installed in the top and bottom nodes, meaning that the top power supply is installed upside-down. This procedure works for installing either power supply.

Steps

1. Align the power supply with the slot in the node.
2. Push the power supply into the node until it clicks into place.

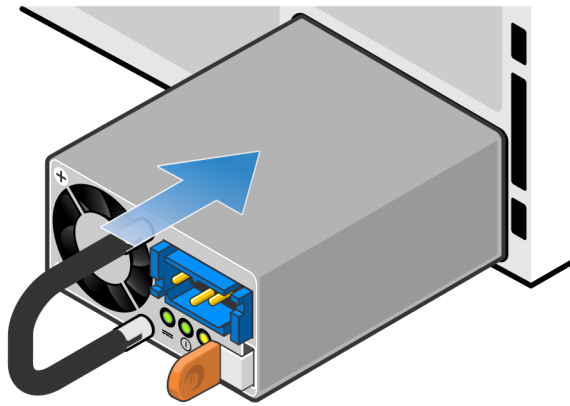

Figure 48. Installing a DC power supply

3. Connect the power cable to the power supply.

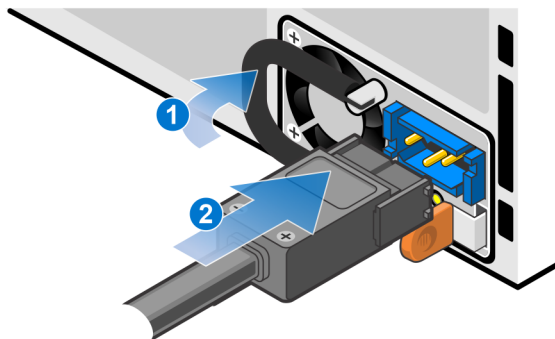

Figure 49. Inserting a DC power cable

Verify the operation of a replacement power supply

Steps

1. From PowerStore Manager, select **Hardware**.
2. Select the appliance where you replaced the power supply.
3. On the **Components** card, under **Rear View**, expand **BaseEnclosure**.
4. Expand the node that includes the power supply, and then select **PSU0**.

The status of the replacement power supply should read `Healthy`. If the status is still `Failed`, wait a few minutes and refresh PowerStore Manager. If the status does not change, ensure that the power supply is correctly seated, or contact your service provider.

Return a faulted part

About this task

For US customers, return defective material within five business days. For International customers, return defective material within 10 business days. The materials required to return your defective part are supplied with the good part shipment.

Steps

1. Package the faulted part in the shipping box that contained the replacement part.
2. Ship the failed part to your service provider as described in the instructions that were included with the replacement part.

3. For more information about returning customer-replaceable parts:
 - a. Open PowerStore Manager.
 - b. Click **Settings** on the upper right of the screen.
 - c. Click **General Support**.
 - d. Under **Drives, Power Supplies, and Other Parts**, click **Return Part**.
 - e. If your screen does not show the Return Part link, contact your service provider for instructions.

Replace a 4-port card

Take the following actions to remove the 4-port card and install the replacement 4-port card into the system.

Before you begin

CAUTION: Before starting this procedure, use the PowerStore Manager Hardware view and Alerts view to verify that the appliance and peer node are healthy with no outstanding alerts. If multiple nodes need to be removed while performing this procedure, repeat this verification for each affected node before proceeding to remove the next node. If necessary, contact your service provider before starting the replacement procedure.

Identify a faulted 4-port card from PowerStore Manager

Before you replace a 4-port card, ensure that you have identified its location within the system. Using PowerStore Manager, you can identify and locate a faulted 4-port card.

Steps

1. From PowerStore Manager, select **Hardware**.
2. Select the appliance that includes the 4-port card that you need to replace.
3. On the **Components** card, under **Rear View**, expand **BaseEnclosure**.
4. Expand the node that includes the 4-port card, and then select **4PortCard**.
Faulted parts appear in red in the image of the system, and report a status of `Failed` in the **State** field.

Embedded module LEDs

Use the fault LEDs to identify the faulted part.

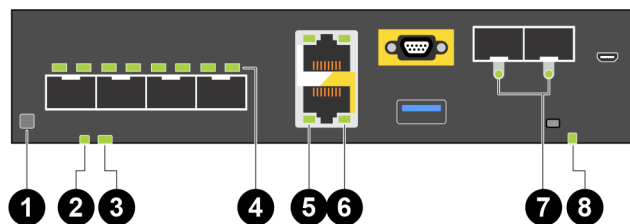

Figure 50. Embedded module LEDs

Table 8. Embedded module LEDs

LED	Location	State	Description
Unsafe to remove	1	White	Do not remove the node. Improper removal could cause data loss.
		Off	Safe to remove the embedded module when the embedded module has been properly prepared.

Table 8. Embedded module LEDs (continued)

LED	Location	State	Description
Node power	2	Green	Node is on (main power).
		Green blinking	Node is initializing a serial over LAN session.
		Off	Node is off.
Node fault	3	Amber	Fault has occurred.
		Blue	Node in Degraded Mode.
		Amber or blue blinking	The system is booting.
		Blue and amber alternating (green for 3 seconds)	System not initialized. A management IP address has not been assigned.
		Blue and amber alternating at one second intervals	Node in Service Mode.
		Off	No fault has occurred, normal operation.
4-port card port link	4	Green	Link up with high speed.
		Amber	Link up with degraded speed.
		Off	Link down.
Ethernet port activity	5	Amber blinking	Port activity.
		Off	No port activity.
Ethernet port link	6	Green	Link established.
		Off	No link established.
2-port card port link	7	Green	Link up with high speed.
		Amber	Link up with degraded speed.
		Off	Link down.
Embedded module fault	8	Amber	Embedded module has faulted.
		Off	No fault has occurred, normal operation.

Power down the node

Power down the node as described in [Power control procedures](#).

Remove the node

This procedure describes how to remove a node from the chassis. There are two nodes. The top node is considered to be upside-down and mirrors the bottom node. The procedure for removing the top node and the bottom node is the same.

Prerequisites

If the I/O modules and network cables are not already labeled, label them clearly for reconnecting later.

About this task

 **WARNING:** Do not remove the node within five minutes of system power off to ensure that the system has had time to complete caching.

CAUTION: Do not remove a node while the "Unsafe to remove" LED is lit. If the LED is lit, the peer node has been powered off or is offline and this node should not be removed.

CAUTION: Because nodes include cooling fans, they should be removed for as short a time as possible. Do not remove nodes from a live system unless replacement parts are available.

Steps

1. Rotate the power cable retention bail to the left (right for top power supply). Disconnect the power cable from the power supply.

The following figure shows an AC power supply.

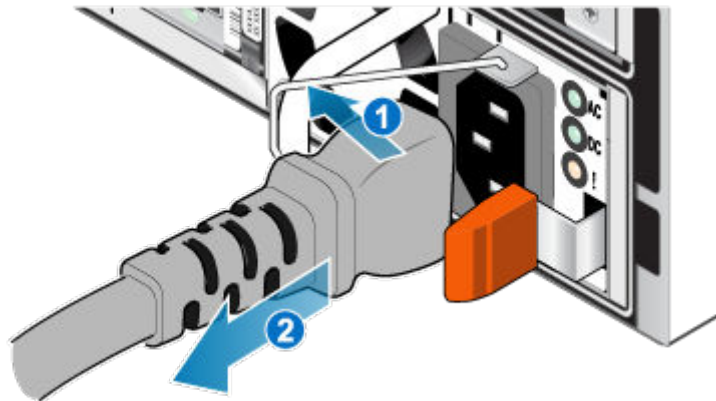

Figure 51. Removing the power cable

2. Disconnect the network and all other cables from the back of the I/O modules and network ports on the node.

NOTE: Label the cables before you remove them.

NOTE: Do not remove any cables from the other node.

3. If the node has a node ID plug on the node handle, remove the node ID plug.

4. Pull the orange release trigger while gently pushing in on the node.

The hook disengages from the locking mechanism, and the release tab slides out.

NOTE: The node comes completely out of the chassis. Be prepared to support the node to avoid dropping it.

NOTE: The release trigger and handle for node B is on the upper left. The release trigger and handle for node A is on the bottom right.

CAUTION: Removing the incorrect node leads to loss of system power and cached data will be lost.

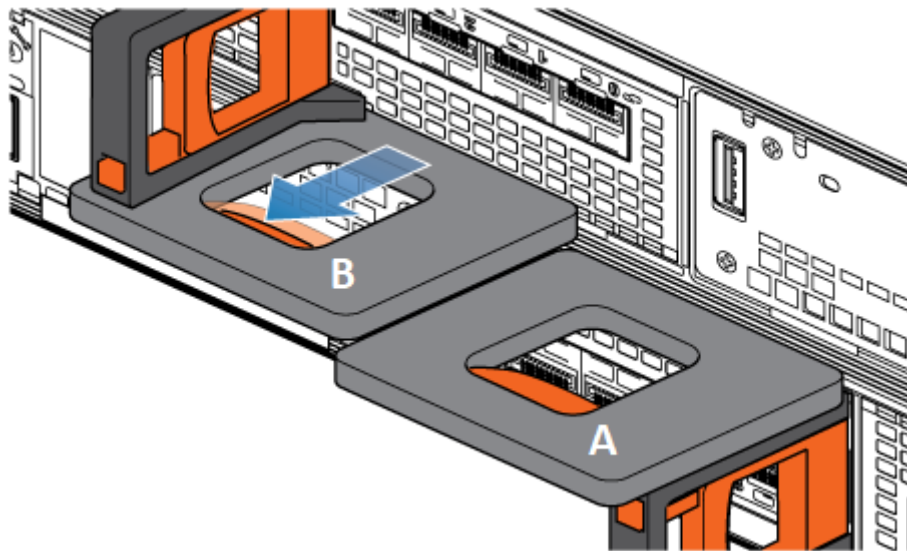

Figure 52. Disengaging the locking mechanism for node B

5. Before removing the node, ensure that the wire bail is properly secured to the power supply cable of the other node to prevent accidental loss of power and cache.
6. Use the release handle to pull the node outward enough to grasp the sides with both hands. Then, with both hands supporting the node, pull the node fully out of the enclosure.

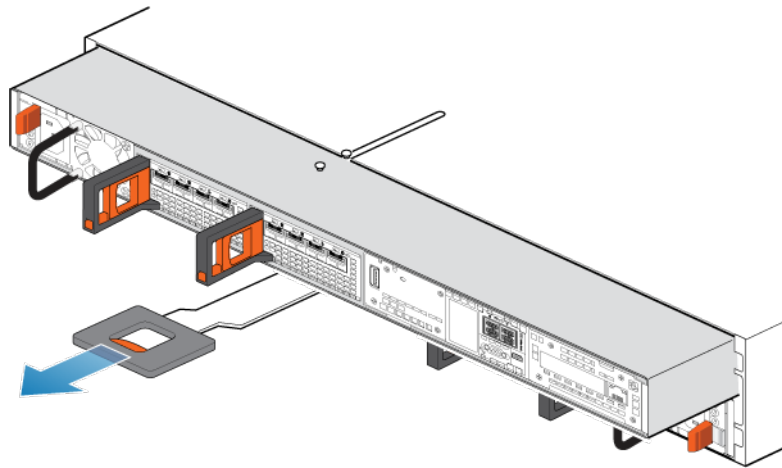

Figure 53. Removing the node

7. Place the node on a clean, flat, static-free work surface.

Remove the embedded module cover from the node

Steps

1. While pushing down the blue release buttons, slide the top cover towards the rear of the system until it stops.
2. Lift the top cover upward, and remove it from the node.

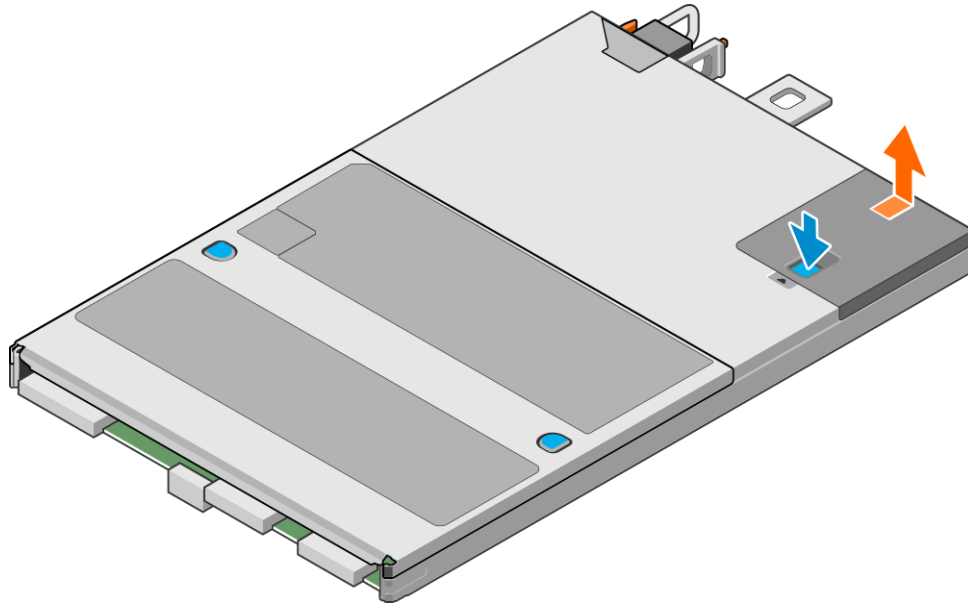

Figure 54. Removing the embedded module cover

Remove a 4-port card

Steps

1. Remove the SFPs from the front of the embedded module.
2. Push down the two blue tabs on the back of the 4-port card to release the 4-port card.

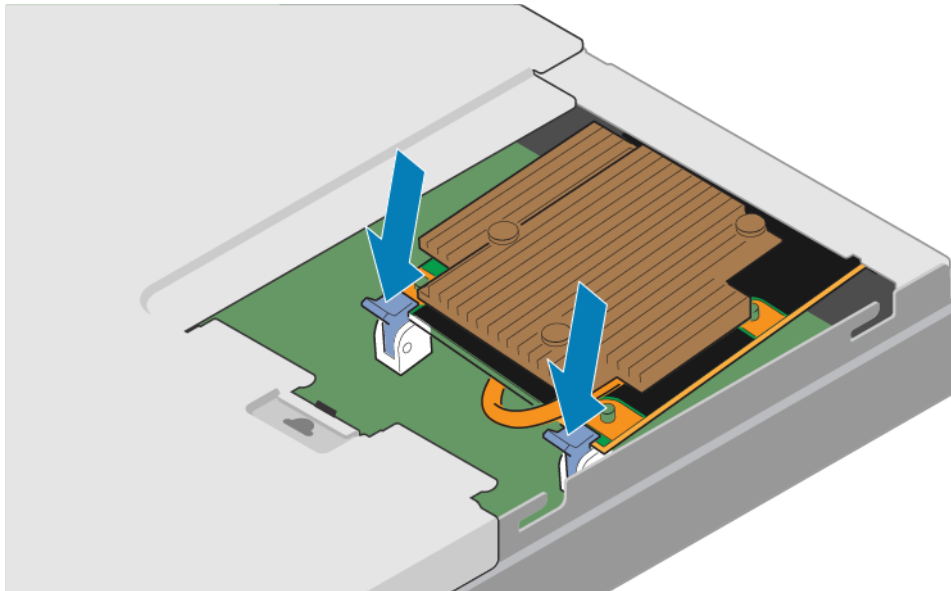

Figure 55. Opening the retaining tabs

3. Lift the 4-port card off the pegs, and pull the 4-port card away from the embedded module.

NOTE: If you are having difficulty removing the 4-port card, loosen the four captive screws that secure the air dam to the front of the embedded module.

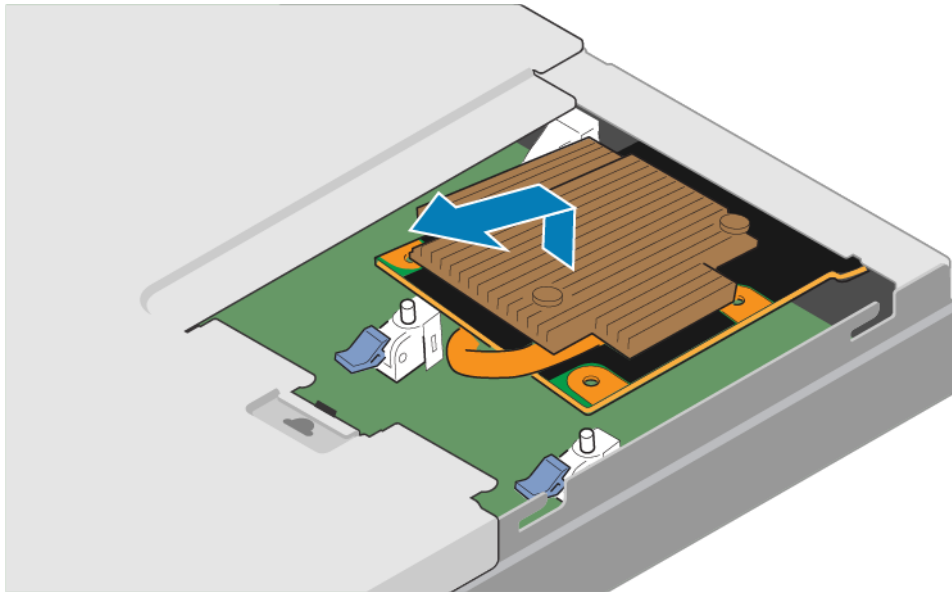



Figure 56. Removing the 4-port card

Install a 4-port card

Steps

1. Align the 4-port card in the embedded module so that the ports on the front line up with the slots on the front of the embedded module.
2. Align the white pegs beneath the holes on the 4-port card.

 **CAUTION:** Do not force the 4-port card into place. If the 4-port card does not smoothly seat, realign the pegs and try again.

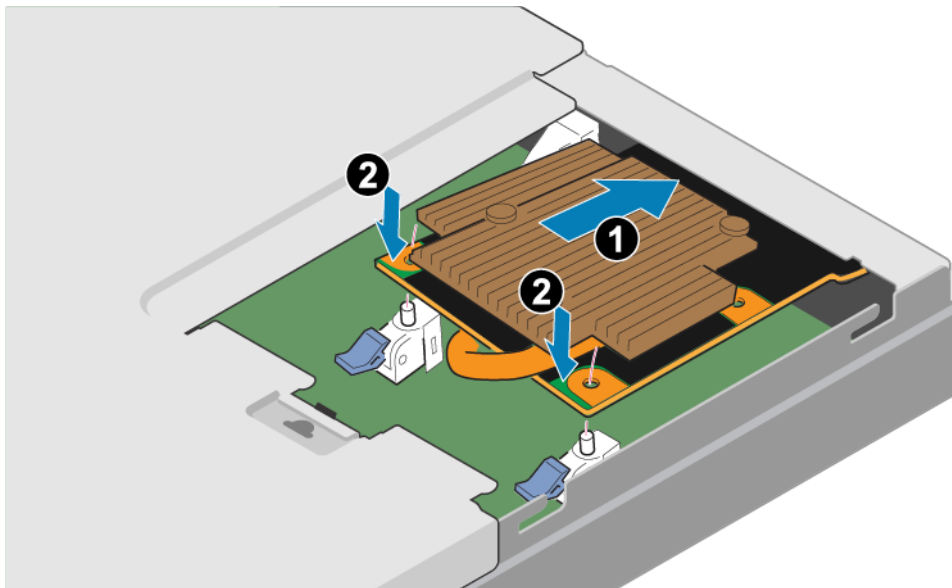

Figure 57. Seating the 4-port card

3. Gently push down on the upper-left circle on the 4-port card.
4. Push up on the blue tabs until they lock into place.

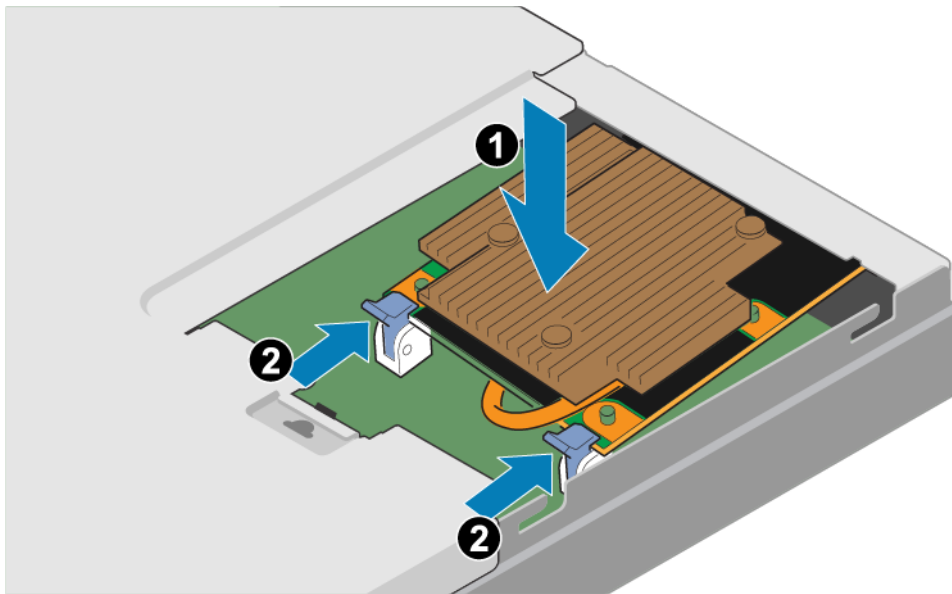

Figure 58. Locking the 4-port card into position

5. If necessary, tighten the four captive screws that secure the air dam to the front of the embedded module.
6. Install the SFPs into the embedded module.

Install the embedded module cover

Steps

1. Position the cover over the embedded module and align it with the slots in the sides.
2. Pull the cover forward to secure it in place.

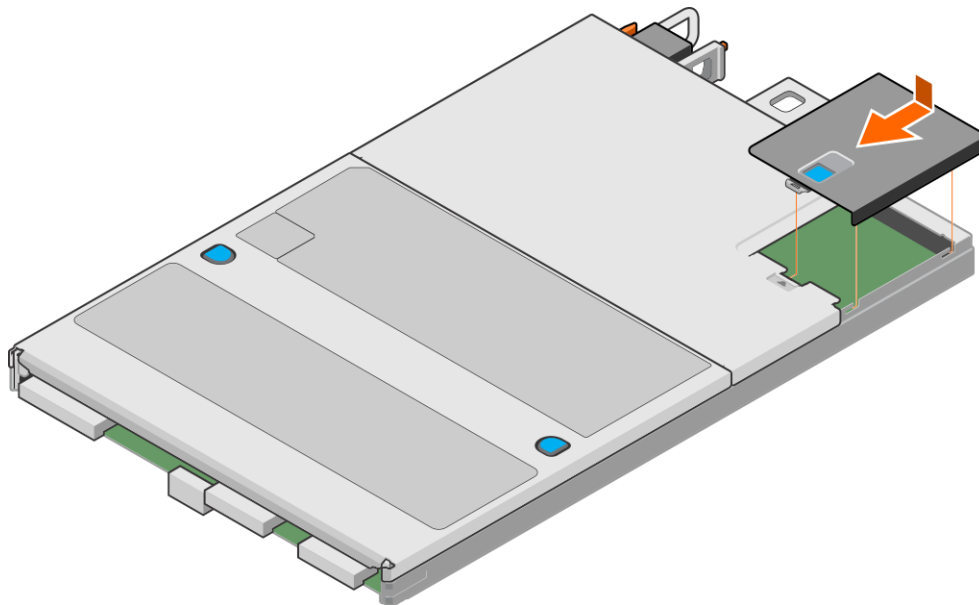

Figure 59. Installing the embedded module cover

Install the node

Steps

1. Align the pins on the top of the node with the grooves on the top of the chassis.
2. Slide the node into the chassis until it stops, about halfway in.

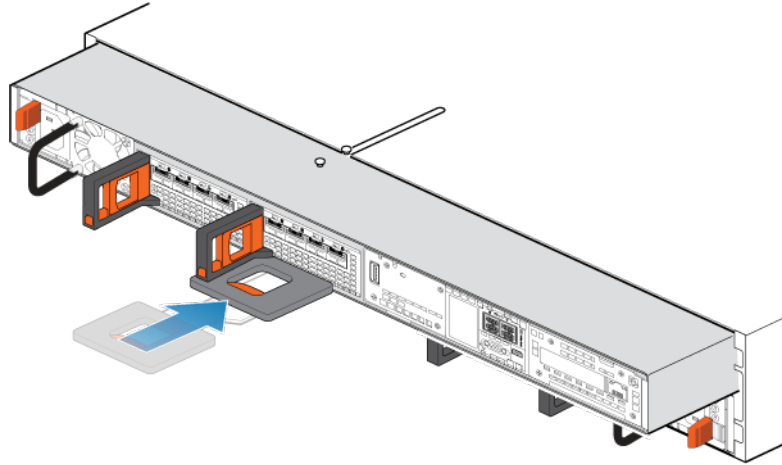

Figure 60. Sliding the node halfway into the chassis

3. Pull the black release tab out completely, and slide the rest of the node back into the chassis. The black release tab slides back into the system as it is inserted.

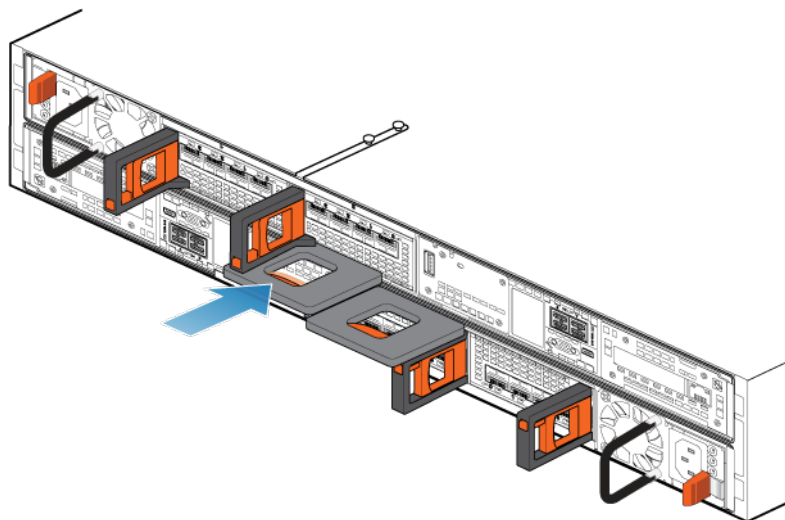

Figure 61. Installing the node

4. Reconnect the back-end cables and the cables to the I/O modules and network ports.
5. Pull the orange release trigger and push in gently to re-engage the locking mechanism. If the black release tab comes out when pulled, the locking mechanism is not engaged.
6. If the node came with a node ID plug, push the node ID plug onto the node handle.
7. Plug in the power cable.

Power up the node

Power up the node as described in [Power control procedures](#).

Verify the operation of a new 4-port card

Steps

1. From PowerStore Manager, select **Hardware**.
2. Select the appliance where you replaced the 4-port card.
3. On the **Components** card, under **Rear View**, expand **BaseEnclosure**.
4. Expand the node that includes the 4-port card, and then select **4PortCard**.

The status of the replacement 4-port card should read `Healthy`. If the status is still `Failed`, wait a few minutes and refresh PowerStore Manager. If the status does not change, ensure that the 4-port card is correctly seated, or contact your service provider.

Return a faulted part

About this task

For US customers, return defective material within five business days. For International customers, return defective material within 10 business days. The materials required to return your defective part are supplied with the good part shipment.

Steps

1. Package the faulted part in the shipping box that contained the replacement part.
2. Ship the failed part to your service provider as described in the instructions that were included with the replacement part.
3. For more information about returning customer-replaceable parts:
 - a. Open PowerStore Manager.
 - b. Click **Settings** on the upper right of the screen.
 - c. Click **General Support**.
 - d. Under **Drives, Power Supplies, and Other Parts**, click **Return Part**.
 - e. If your screen does not show the Return Part link, contact your service provider for instructions.

Replace an SFP

Take the following actions to remove the faulted SFP and install the replacement SFP into the system.

Identify a faulted SFP module from PowerStore Manager

Using PowerStore Manager, you can identify and locate a faulted SFP module.

Steps

1. From PowerStore Manager, select **Hardware > Appliances**.
2. Select the appliance that contains the SFP module that you need to replace.
3. On the **Components** card, under **Rear View**, expand **BaseEnclosure**.
4. Expand the node that includes the SFP module, and select the SFP module under either **4PortCard** or **IOModule**.
Faulted parts appear in red in the image of the system, and report a status of `Failed` in the **State** field.
5. The following error messages do not result in a fault, but they still indicate that the SFP should be replaced.
 - SFP speed mismatched: Indicates that the supported speeds of this SFP module are unsupported by the port.
 - SFP unsupported: Indicates that this SFP module is not qualified with this product.
 - SFP asymmetric: Indicates that this SFP module does not have the same supported speeds and connector type as its partner.

Remove an SFP module

Steps

1. If a cable is connected to the SFP, disconnect the cable.
2. Gently pull down on the spring release latch.
3. While still holding onto the latch, gently pull out the SFP module.

CAUTION: Do not remove the I/O module. Removing the I/O module causes the node to reboot immediately.

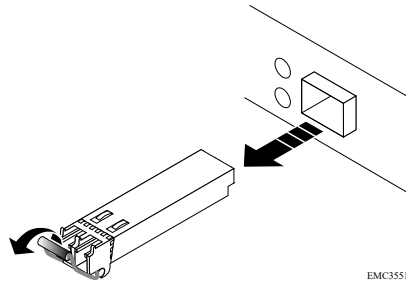

Figure 62. Removing an SFP module

Install an SFP module

Steps

1. Verify that the replacement SFP module has the same part number as the failed SFP module. The part number is on a label that is attached to the SFP module.
2. Push the spring release latch up and slide the new SFP module into the port until it is securely connected.

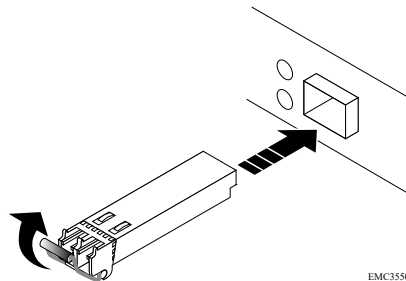

Figure 63. Installing an SFP module

3. Push the spring release down to lock the SFP module into place.
4. Reconnect the cable to the replacement SFP module.

Verify the operation of a replacement SFP module

Steps

1. From PowerStore Manager, select **Hardware > Appliances**.
2. Select the appliance where you replaced the SFP module.
3. On the **Components** card, under **Rear View**, expand **BaseEnclosure**.
4. Expand the node that includes the SFP module, and select the SFP module under either **4PortCard** or **IOModule**.
5. The status of the replacement SFP module should read **Healthy**. If the status is still **Failed**, wait a few minutes and refresh PowerStore Manager. If the fault was indicated by one of the following error messages, verify that the error message is cleared:

- SFP speed mismatched
- SFP unsupported
- SFP asymmetric

If the status does not change or the error message is not cleared, ensure that the SFP module is correctly seated, or contact your service provider.

Return a faulted part

About this task

For US customers, return defective material within five business days. For International customers, return defective material within 10 business days. The materials required to return your defective part are supplied with the good part shipment.

Steps

1. Package the faulted part in the shipping box that contained the replacement part.
2. Ship the failed part to your service provider as described in the instructions that were included with the replacement part.
3. For more information about returning customer-replaceable parts:
 - a. Open PowerStore Manager.
 - b. Click **Settings** on the upper right of the screen.
 - c. Click **General Support**.
 - d. Under **Drives, Power Supplies, and Other Parts**, click **Return Part**.
 - e. If your screen does not show the Return Part link, contact your service provider for instructions.

Replace an I/O module

Take the following actions to remove the faulted I/O module and install the replacement I/O module into the system.

Before you begin

 **CAUTION:** Before starting this procedure, use the PowerStore Manager Hardware view and Alerts view to verify that the appliance and peer node are healthy with no outstanding alerts. If multiple nodes need to be removed while performing this procedure, repeat this verification for each affected node before proceeding to remove the next node. If necessary, contact your service provider before starting the replacement procedure.

Identify a faulted I/O module from PowerStore Manager

Before you replace an I/O module, ensure that you have identified its location within the system. Using PowerStore Manager, you can identify and locate a faulted I/O module.

Steps

1. From PowerStore Manager, select **Hardware > Appliances**.
2. Select the appliance that includes the I/O module that you need to replace.
3. On the **Components** card, under **Rear View**, expand **BaseEnclosure**.
4. Expand the node that includes the I/O module, and then select the relevant **IoModule**.
Faulted parts appear in red in the image of the system, and report a status of `Failed` in the **State** field.

Base enclosure I/O module LEDs

Use the fault LEDs to identify the faulted part.

NOTE: The ports look different depending on whether they are for copper or optical connections. The image below shows ports for copper cables.

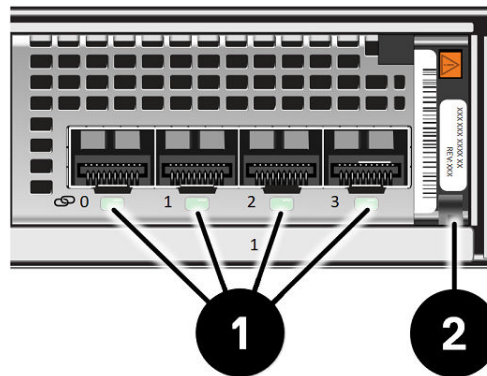

Figure 64. Base enclosure I/O module LEDs

Table 9. Base enclosure I/O module LEDs

LED	Location	State	Description
Port link	1	Green or blue	Link up
		Off	Link down
Power/Fault	2	Green	Power on
		Amber	Fault

Power down the node

Power down the node as described in [Power control procedures](#).

Remove an I/O module

Steps

1. Pull the trigger mechanism on the I/O module handle to release it.

CAUTION: Do not pull the node from the base enclosure.

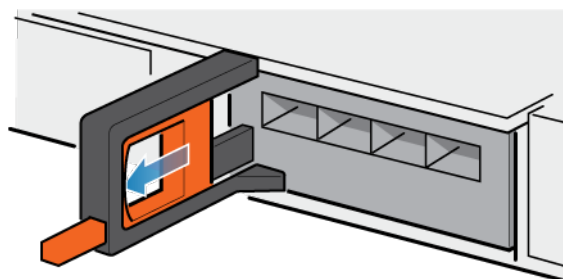

Figure 65. Releasing the I/O module

2. Gently pull the I/O module from the slot.

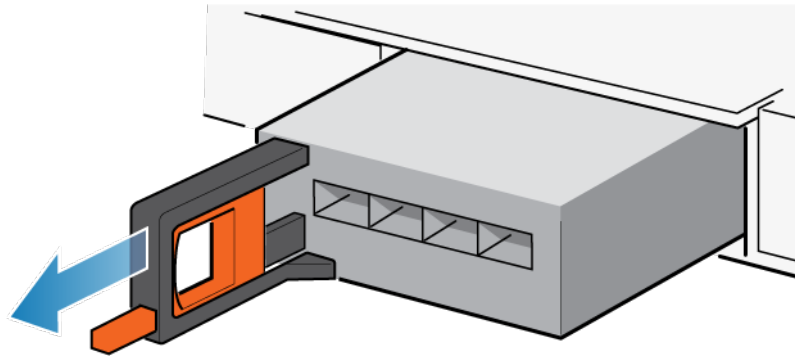

Figure 66. Removing the I/O module

Install an I/O module

Steps

1. Align the module with the empty slot and carefully push the module into the slot.

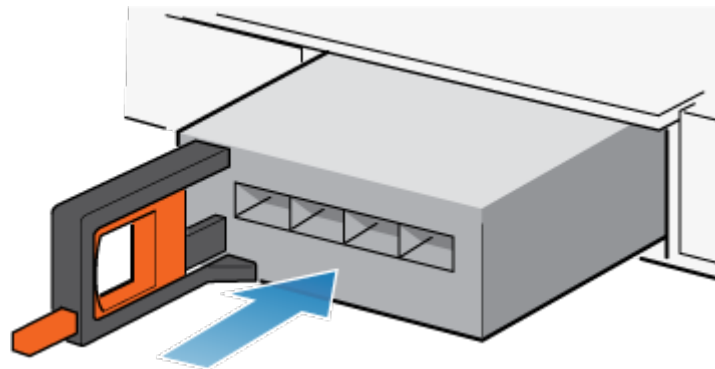

Figure 67. Installing an I/O module

2. When the I/O module appears seated, push and release the small button on the handle.
 - If the button remains in, the module is fully seated.
 - If the button springs back, gently push the module further into the chassis, then push it again.
 - If the button still does not rest flush with its handle, remove the module and repeat steps 1 and 2.

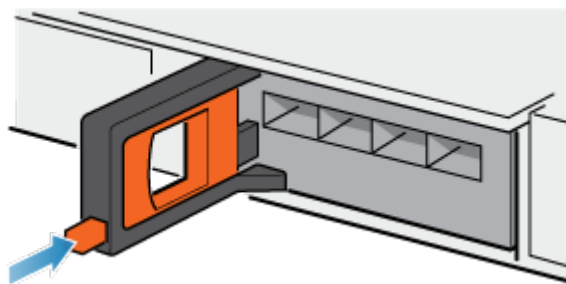

Figure 68. Locking the I/O module into place

3. Connect the cables into the assigned I/O module ports.

Power up the node

Power up the node as described in [Power control procedures](#).

Verify the operation of a replacement I/O module

Steps

1. From PowerStore Manager, select **Hardware**.
2. Select the appliance where you replaced the I/O module.
3. On the **Components** card, under **Rear View**, expand **BaseEnclosure**.
4. Expand the node that includes the I/O module, and then select the relevant **IoModule**.
The status of the replacement I/O module should read `Healthy`. If the status is still `Failed`, wait a few minutes and refresh PowerStore Manager. If the status does not change, ensure that the I/O module is correctly seated, or contact your service provider.

Return a faulted part

About this task

For US customers, return defective material within five business days. For International customers, return defective material within 10 business days. The materials required to return your defective part are supplied with the good part shipment.

Steps

1. Package the faulted part in the shipping box that contained the replacement part.
2. Ship the failed part to your service provider as described in the instructions that were included with the replacement part.
3. For more information about returning customer-replaceable parts:
 - a. Open PowerStore Manager.
 - b. Click **Settings** on the upper right of the screen.
 - c. Click **General Support**.
 - d. Under **Drives, Power Supplies, and Other Parts**, click **Return Part**.
 - e. If your screen does not show the Return Part link, contact your service provider for instructions.

Replace a fan module

Take the following actions to remove the faulted fan module and install the replacement fan module into the system.

Before you begin

 **CAUTION:** Before starting this procedure, use the PowerStore Manager Hardware view and Alerts view to verify that the appliance and peer node are healthy with no outstanding alerts. If multiple nodes need to be removed while performing this procedure, repeat this verification for each affected node before proceeding to remove the next node. If necessary, contact your service provider before starting the replacement procedure.

Identify a faulted fan module from PowerStore Manager

Before you replace a fan module, ensure that you have identified its location within the system. Using PowerStore Manager, you can identify and locate a faulted fan module.

Steps

1. From PowerStore Manager, select **Hardware > Appliances**.
2. Select the appliance that includes the fan module that you need to replace.
3. On the **Components** card, under **Internal View**, expand the node that includes the fan module, and then select the relevant **FanModule**.
Faulted parts appear in red in the image of the system, and report a status of `Failed` in the **State** field.

Power down the node

Power down the node as described in [Power control procedures](#).

Remove the node

This procedure describes how to remove a node from the chassis. There are two nodes. The top node is considered to be upside-down and mirrors the bottom node. The procedure for removing the top node and the bottom node is the same.

Prerequisites

If the I/O modules and network cables are not already labeled, label them clearly for reconnecting later.

About this task

- ⚠ WARNING:** Do not remove the node within five minutes of system power off to ensure that the system has had time to complete caching.
- ⚠ CAUTION:** Do not remove a node while the "Unsafe to remove" LED is lit. If the LED is lit, the peer node has been powered off or is offline and this node should not be removed.
- ⚠ CAUTION:** Because nodes include cooling fans, they should be removed for as short a time as possible. Do not remove nodes from a live system unless replacement parts are available.

Steps

1. Rotate the power cable retention bail to the left (right for top power supply). Disconnect the power cable from the power supply.

The following figure shows an AC power supply.

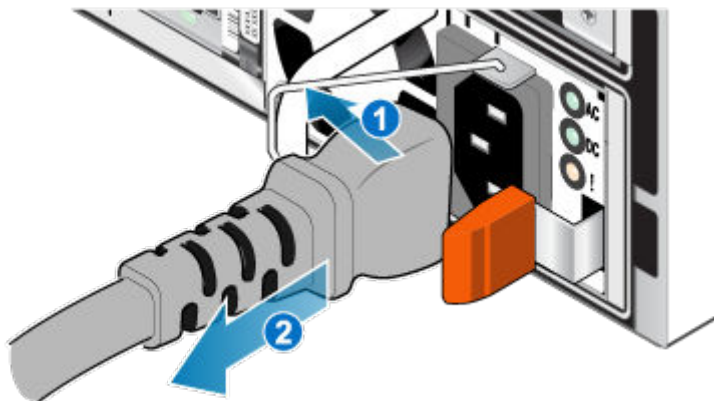

Figure 69. Removing the power cable

2. Disconnect the network and all other cables from the back of the I/O modules and network ports on the node.

i NOTE: Label the cables before you remove them.

i NOTE: Do not remove any cables from the other node.

3. If the node has a node ID plug on the node handle, remove the node ID plug.

4. Pull the orange release trigger while gently pushing in on the node.

The hook disengages from the locking mechanism, and the release tab slides out.

i NOTE: The node comes completely out of the chassis. Be prepared to support the node to avoid dropping it.

i NOTE: The release trigger and handle for node B is on the upper left. The release trigger and handle for node A is on the bottom right.

CAUTION: Removing the incorrect node leads to loss of system power and cached data will be lost.

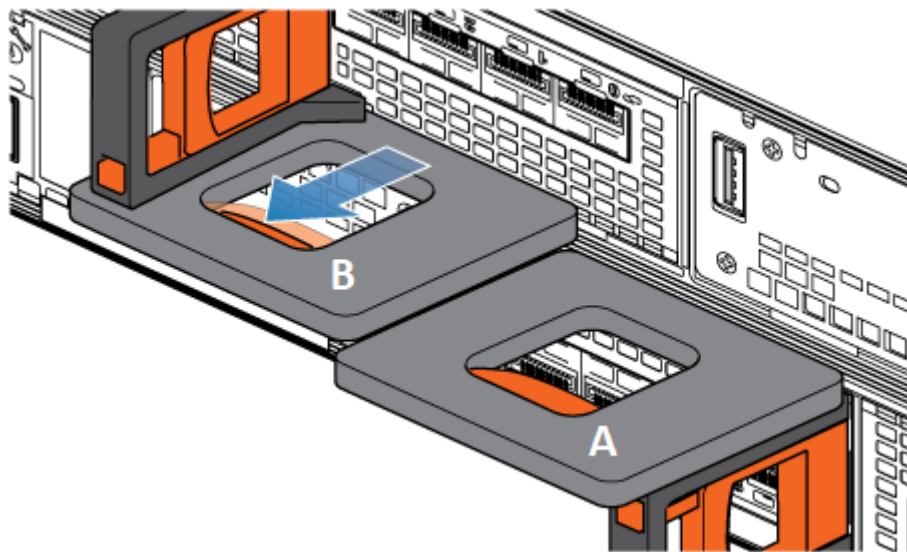

Figure 70. Disengaging the locking mechanism for node B

5. Before removing the node, ensure that the wire bail is properly secured to the power supply cable of the other node to prevent accidental loss of power and cache.
6. Use the release handle to pull the node outward enough to grasp the sides with both hands. Then, with both hands supporting the node, pull the node fully out of the enclosure.

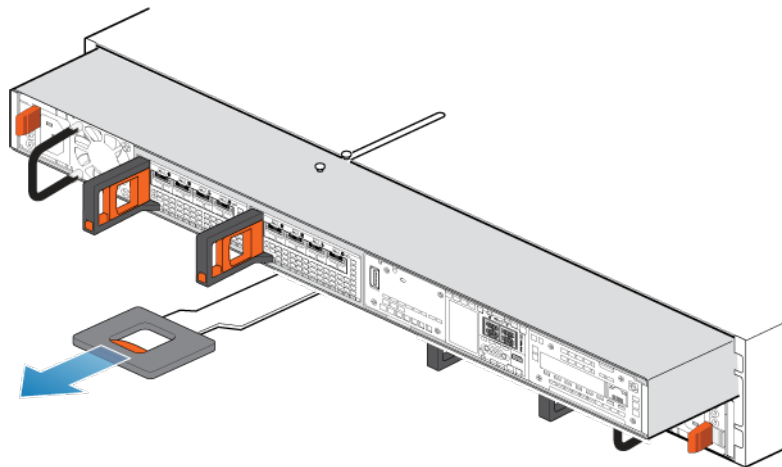

Figure 71. Removing the node

7. Place the node on a clean, flat, static-free work surface.

Remove the top cover from the node

Steps

1. While pushing down the two blue release buttons, slide the top cover towards the rear of the system, until it stops.
2. Lift the top cover upward, and remove it from the node.

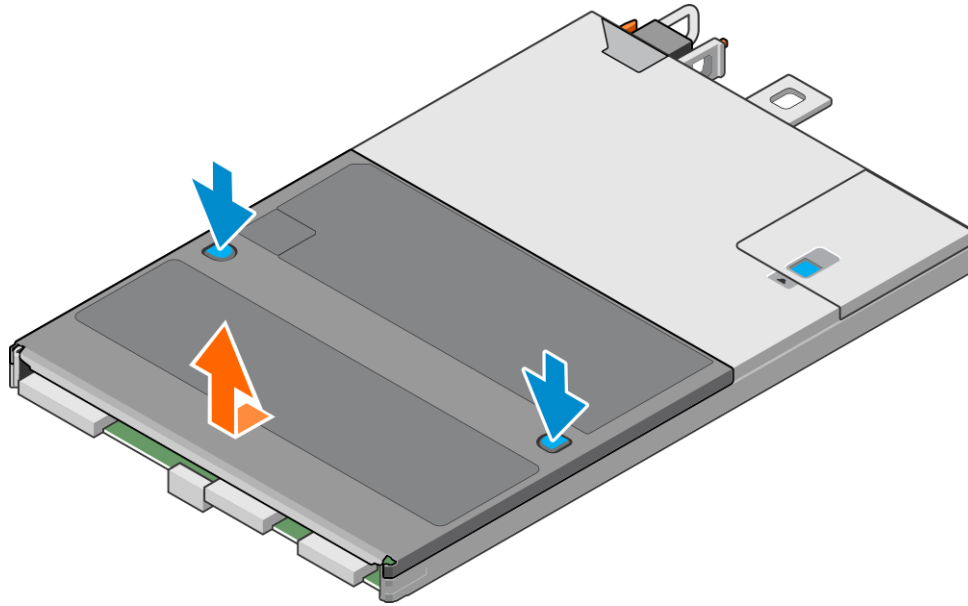

Figure 72. Removing the top cover

Remove the fan module

Steps

1. Disconnect the fan module power cable from the motherboard.

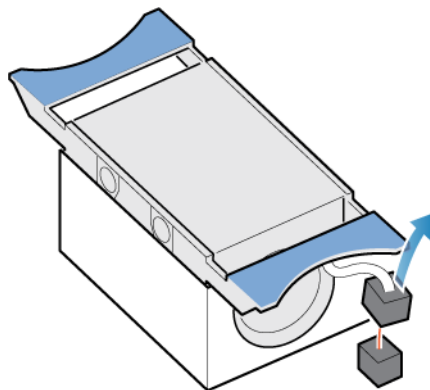

Figure 73. Disconnecting the fan power cable

2. Unhook the fan module power cable from the cable holder.
3. Squeeze the blue release tabs.
4. Lift the fan module away from the motherboard.

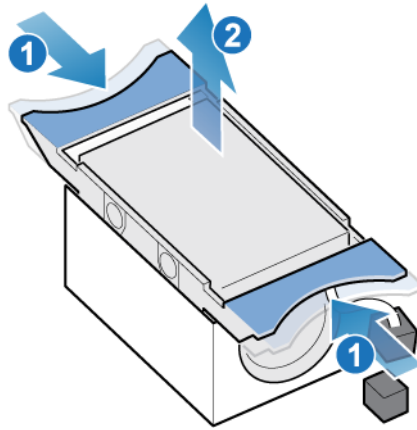

Figure 74. Removing the fan from the motherboard

Install the fan module

Steps

1. Place the fan module into the mounting position in the node.
2. Squeeze the blue tabs and press downward to lock the fan module into position.
3. Connect the fan module power cable to the connector on the motherboard.

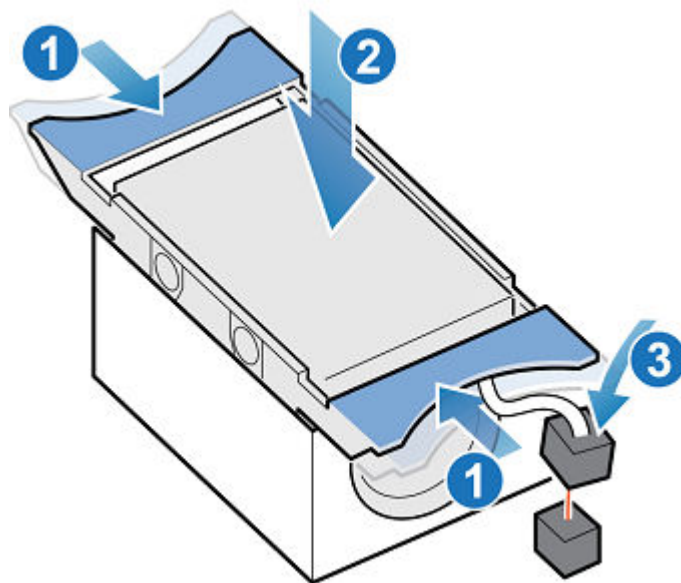

Figure 75. Installing the fan module

Install the top cover on the node

Steps

1. Position the top cover over the node and align it with the slots in the sides at the rear of the node.
2. Pull the top cover forward to secure it in place.

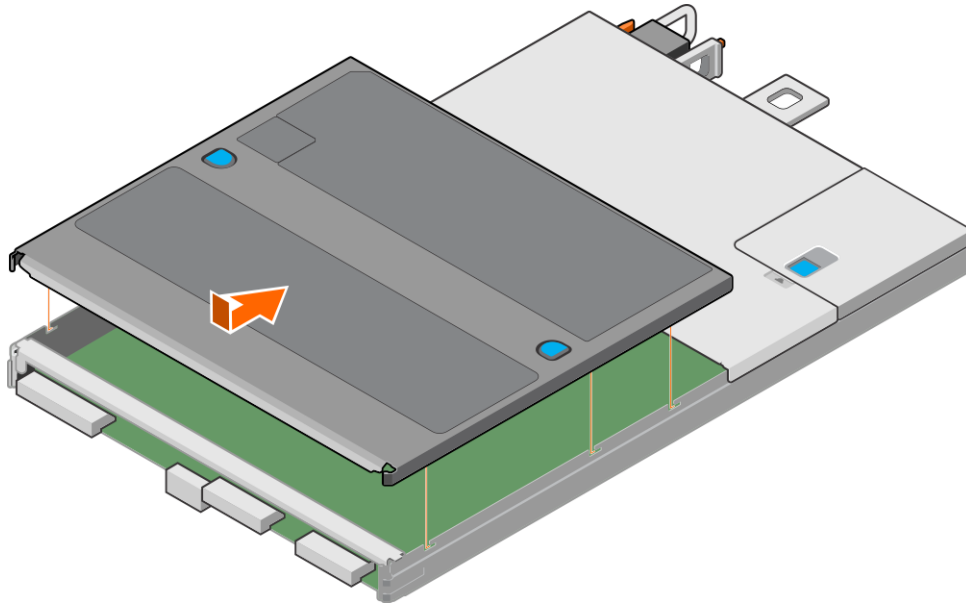

Figure 76. Installing the top cover

Install the node

Steps

1. Align the pins on the top of the node with the grooves on the top of the chassis.
2. Slide the node into the chassis until it stops, about halfway in.

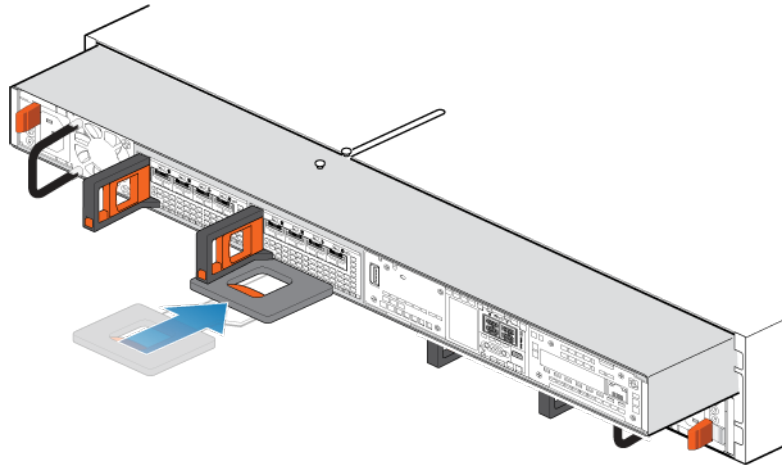

Figure 77. Sliding the node halfway into the chassis

3. Pull the black release tab out completely, and slide the rest of the node back into the chassis. The black release tab slides back into the system as it is inserted.

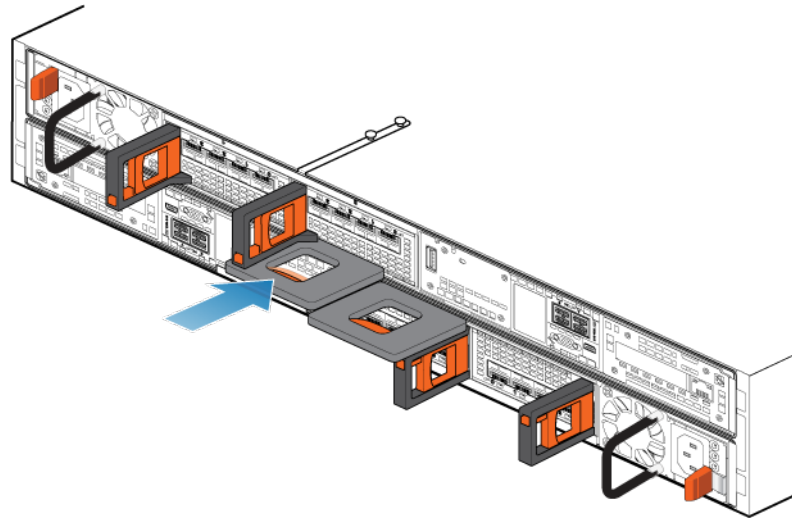

Figure 78. Installing the node

4. Reconnect the back-end cables and the cables to the I/O modules and network ports.
5. Pull the orange release trigger and push in gently to re-engage the locking mechanism.
If the black release tab comes out when pulled, the locking mechanism is not engaged.
6. If the node came with a node ID plug, push the node ID plug onto the node handle.
7. Plug in the power cable.

Verify the operation of a replacement fan module

Steps

1. From PowerStore Manager, select **Hardware > Appliances**.
2. Select the appliance where you replaced the fan module.
3. On the **Components** card, under **Internal View**, expand the node that includes the fan module, and then select the relevant **FanModule**.

The status of the replacement fan module should read `Healthy`. If the status is still `Faulted`, wait a few minutes and refresh PowerStore Manager. If the status does not change, ensure that the fan module is correctly seated, or contact your service provider.

Return a faulted part

About this task

For US customers, return defective material within five business days. For International customers, return defective material within 10 business days. The materials required to return your defective part are supplied with the good part shipment.

Steps

1. Package the faulted part in the shipping box that contained the replacement part.
2. Ship the failed part to your service provider as described in the instructions that were included with the replacement part.
3. For more information about returning customer-replaceable parts:
 - a. Open PowerStore Manager.
 - b. Click **Settings** on the upper right of the screen.
 - c. Click **General Support**.
 - d. Under **Drives, Power Supplies, and Other Parts**, click **Return Part**.
 - e. If your screen does not show the Return Part link, contact your service provider for instructions.

Replace a dual inline memory module (DIMM)

Take the following actions to remove the faulted DIMM and install the replacement DIMM into the system.

The DIMMs are located within the node. You can access the DIMMs by removing the node from the chassis and opening the top cover.

 **NOTE:** The DIMMs must stay in their original position. Do not move any DIMMs to a different slot.

Before you begin

 **CAUTION:** Before starting this procedure, use the PowerStore Manager Hardware view and Alerts view to verify that the appliance and peer node are healthy with no outstanding alerts. If multiple nodes need to be removed while performing this procedure, repeat this verification for each affected node before proceeding to remove the next node. If necessary, contact your service provider before starting the replacement procedure.

Identify a faulted DIMM from PowerStore Manager

Before you replace a DIMM, ensure that you have identified its location within the system. Using PowerStore Manager, you can identify and locate a faulted DIMM.

Steps

1. From PowerStore Manager, select **Hardware > Appliances**.
2. Select the appliance that includes the DIMM that you need to replace.
3. On the **Components** card, under **Internal View**, expand the node that includes the DIMM, and then select the relevant **DIMM**.

Faulted parts appear in red in the image of the system, and report a status of `Failed` in the **State** field.

Power down the node

Power down the node as described in [Power control procedures](#).

Remove the node

This procedure describes how to remove a node from the chassis. There are two nodes. The top node is considered to be upside-down and mirrors the bottom node. The procedure for removing the top node and the bottom node is the same.

Prerequisites

If the I/O modules and network cables are not already labeled, label them clearly for reconnecting later.

About this task

 **WARNING:** Do not remove the node within five minutes of system power off to ensure that the system has had time to complete caching.

 **CAUTION:** Do not remove a node while the "Unsafe to remove" LED is lit. If the LED is lit, the peer node has been powered off or is offline and this node should not be removed.

 **CAUTION:** Because nodes include cooling fans, they should be removed for as short a time as possible. Do not remove nodes from a live system unless replacement parts are available.

Steps

1. Rotate the power cable retention bail to the left (right for top power supply). Disconnect the power cable from the power supply.

The following figure shows an AC power supply.

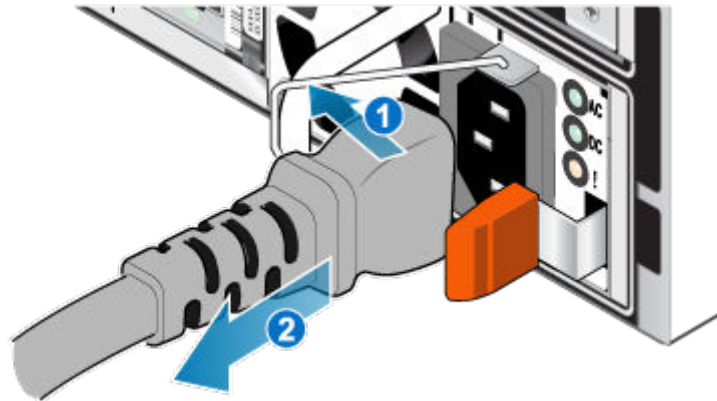

Figure 79. Removing the power cable

2. Disconnect the network and all other cables from the back of the I/O modules and network ports on the node.

NOTE: Label the cables before you remove them.

NOTE: Do not remove any cables from the other node.

3. If the node has a node ID plug on the node handle, remove the node ID plug.

4. Pull the orange release trigger while gently pushing in on the node.

The hook disengages from the locking mechanism, and the release tab slides out.

NOTE: The node comes completely out of the chassis. Be prepared to support the node to avoid dropping it.

NOTE: The release trigger and handle for node B is on the upper left. The release trigger and handle for node A is on the bottom right.

CAUTION: Removing the incorrect node leads to loss of system power and cached data will be lost.

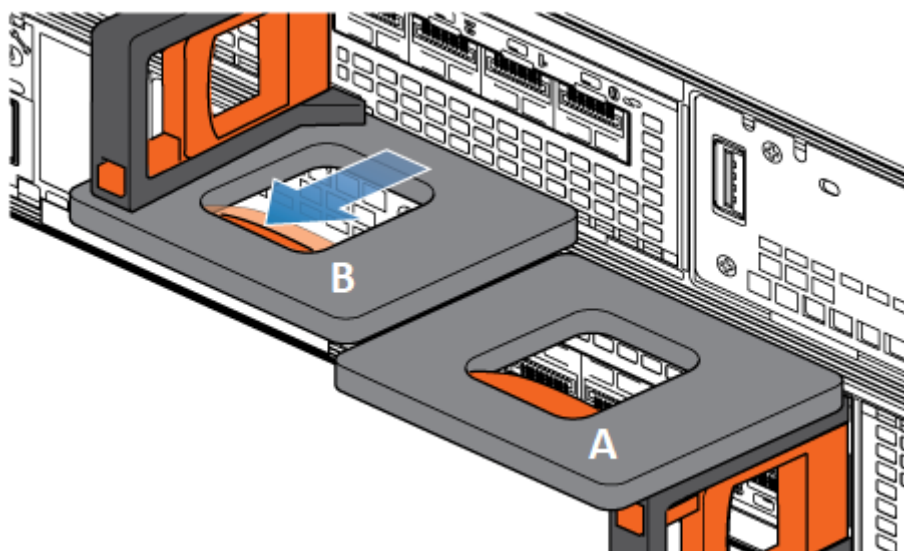

Figure 80. Disengaging the locking mechanism for node B

5. Before removing the node, ensure that the wire bail is properly secured to the power supply cable of the other node to prevent accidental loss of power and cache.
6. Use the release handle to pull the node outward enough to grasp the sides with both hands. Then, with both hands supporting the node, pull the node fully out of the enclosure.

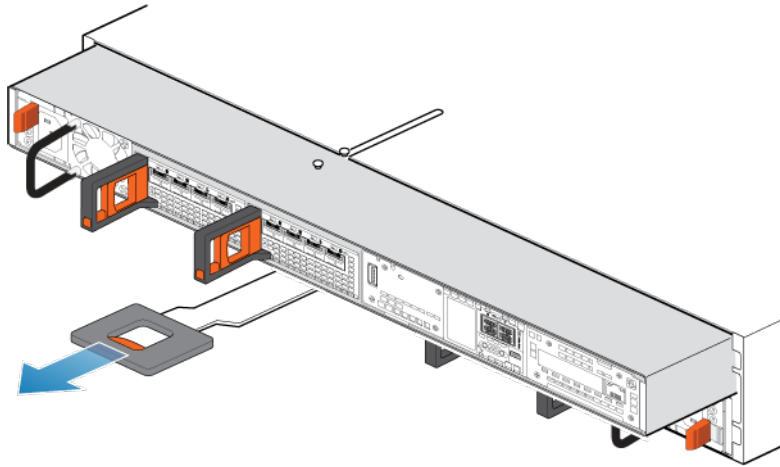

Figure 81. Removing the node

7. Place the node on a clean, flat, static-free work surface.

Remove the top cover from the node

Steps

1. While pushing down the two blue release buttons, slide the top cover towards the rear of the system, until it stops.
2. Lift the top cover upward, and remove it from the node.

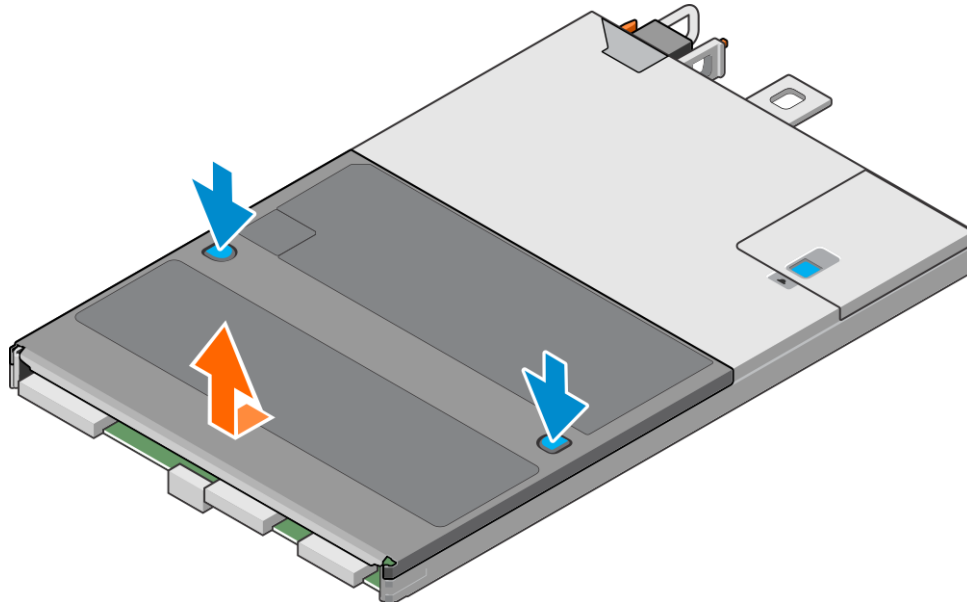

Figure 82. Removing the top cover

Remove the dual inline memory module

Steps

1. Locate the faulted DIMM in the node.
The DIMMs have white or black retaining tabs.

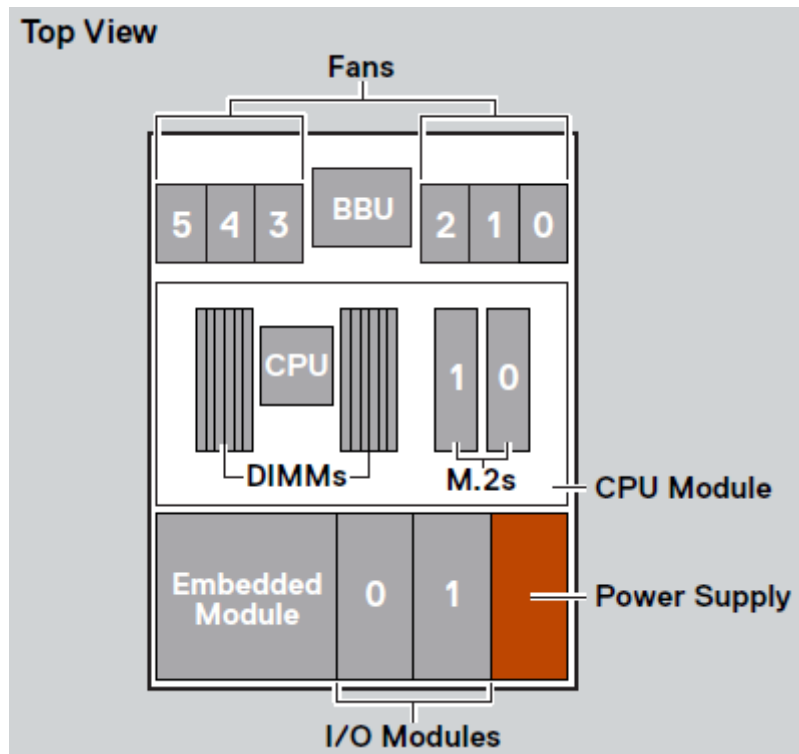

Figure 83. Top view of the node

NOTE: The leftmost DIMM slot is 11, and the slots decrease sequentially to slot 0 on the far right.

2. Press the white or black retaining tabs downward to free the DIMM from its slot.
3. Remove the faulted DIMM.

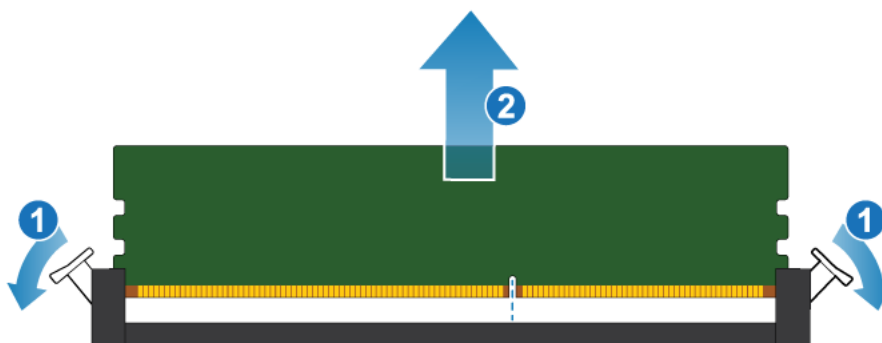

Figure 84. Removing the DIMM

Install the dual inline memory module

Steps

1. Touching only the outside edges of the DIMM, align the DIMM with the connector.

2. Press the DIMM vertically down into the socket using pressure at each end while keeping the leading edge of the DIMM parallel to the connector until it fully seats to the bottom of the socket. When the DIMM engages the contacts in the socket, you will feel resistance, and slightly more force is required to push the module down. During this stage, keep in mind the following precautions:
 - Do not insert the DIMM at an angle.
 - Do not rock the DIMM.
 - Do not insert the DIMM by pushing on one end.
 - Do not seat one end of the DIMM and then the other.

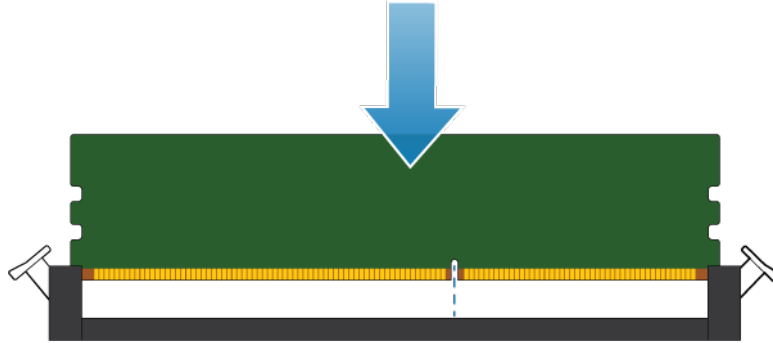

Figure 85. Installing the DIMM

3. Proper DIMM insertion will automatically close the latch ejectors and lock the DIMM into the socket. Verify that the latch ejectors are fully closed and have engaged the notches in the DIMM.

Install the top cover on the node

Steps

1. Position the top cover over the node and align it with the slots in the sides at the rear of the node.
2. Pull the top cover forward to secure it in place.

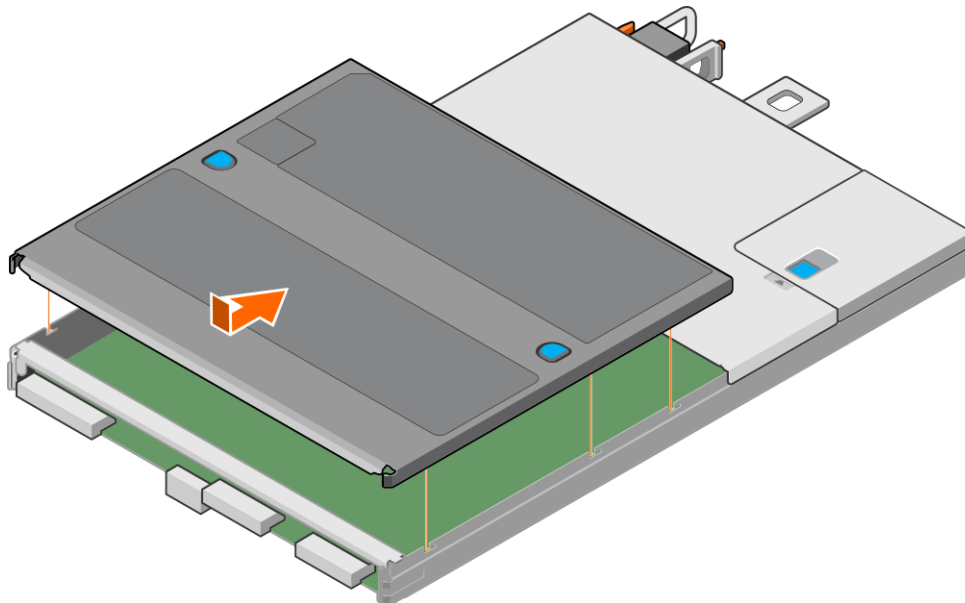

Figure 86. Installing the top cover

Install the node

Steps

1. Align the pins on the top of the node with the grooves on the top of the chassis.
2. Slide the node into the chassis until it stops, about halfway in.

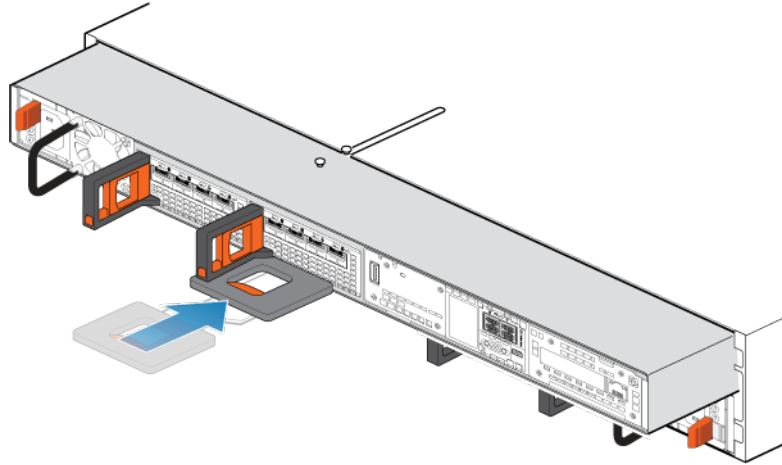

Figure 87. Sliding the node halfway into the chassis

3. Pull the black release tab out completely, and slide the rest of the node back into the chassis. The black release tab slides back into the system as it is inserted.

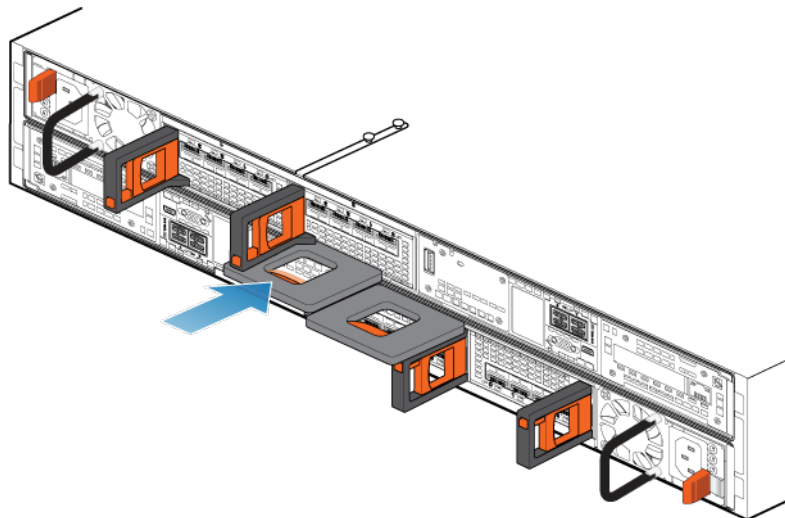

Figure 88. Installing the node

4. Reconnect the back-end cables and the cables to the I/O modules and network ports.
5. Pull the orange release trigger and push in gently to re-engage the locking mechanism. If the black release tab comes out when pulled, the locking mechanism is not engaged.
6. If the node came with a node ID plug, push the node ID plug onto the node handle.
7. Plug in the power cable.

Verify the operation of a replacement DIMM

Steps

1. From PowerStore Manager, select **Hardware**.

2. Select the appliance where you replaced the DIMM.
3. On the **Components** card, under **Internal View**, expand the node that includes the DIMM, and then select the relevant **DIMM**.
The status of the replacement DIMM should read `Healthy`. If the status is still `Failed`, wait a few minutes and refresh PowerStore Manager. If the status does not change, ensure that the DIMM is correctly seated, or contact your service provider.

Return a faulted part

About this task

For US customers, return defective material within five business days. For International customers, return defective material within 10 business days. The materials required to return your defective part are supplied with the good part shipment.

Steps

1. Package the faulted part in the shipping box that contained the replacement part.
2. Ship the failed part to your service provider as described in the instructions that were included with the replacement part.
3. For more information about returning customer-replaceable parts:
 - a. Open PowerStore Manager.
 - b. Click **Settings** on the upper right of the screen.
 - c. Click **General Support**.
 - d. Under **Drives, Power Supplies, and Other Parts**, click **Return Part**.
 - e. If your screen does not show the Return Part link, contact your service provider for instructions.

Replace an internal M.2 boot module

Take the following actions to remove the faulted internal M.2 boot module and install the replacement internal M.2 boot module into the system.

The internal M.2 boot module is located within the node. You can access the internal M.2 boot module by removing the node from the chassis and opening the top cover.

Before you begin

 **CAUTION:** Before starting this procedure, use the PowerStore Manager Hardware view and Alerts view to verify that the appliance and peer node are healthy with no outstanding alerts. If multiple nodes need to be removed while performing this procedure, repeat this verification for each affected node before proceeding to remove the next node. If necessary, contact your service provider before starting the replacement procedure.

Identify a faulted internal M.2 boot module from PowerStore Manager

Before you replace an internal M.2 boot module, ensure that you have identified its location within the system. Using PowerStore Manager, you can identify and locate a faulted part.

Steps

1. From PowerStore Manager, select **Hardware > Appliances**.
2. Select the appliance that includes the internal M.2 boot module that you need to replace.
3. On the **Components** card, under **Internal View**, expand the node that includes the internal M.2 boot module, and then select the relevant **InternalM.2BootModule**.
Faulted parts appear in red in the image of the system, and report a status of `Failed` in the **State** field.

Establish connectivity to the peer node via SSH

Before beginning the replacement procedure, ensure that your connection to the peer node is working correctly.

About this task

CAUTION: Before you begin this procedure, establish a connection to the healthy node to run service commands via SSH. You need to run the `svc_repair` command immediately after re-inserting the node to allow the system to reimage the new internal M.2 boot module from the surviving node. To prevent time out issues with the `svc_repair` command, it is important to first resolve any problems with the connection.

Steps

1. Launch an SSH client, and connect to the appliance using the peer node IP address.
2. Enter the username and password for the service account to log in.

Power down the node

Power down the node as described in [Power control procedures](#).

Remove the node

This procedure describes how to remove a node from the chassis. There are two nodes. The top node is considered to be upside-down and mirrors the bottom node. The procedure for removing the top node and the bottom node is the same.

Prerequisites

If the I/O modules and network cables are not already labeled, label them clearly for reconnecting later.

About this task

WARNING: Do not remove the node within five minutes of system power off to ensure that the system has had time to complete caching.

CAUTION: Do not remove a node while the "Unsafe to remove" LED is lit. If the LED is lit, the peer node has been powered off or is offline and this node should not be removed.

CAUTION: Because nodes include cooling fans, they should be removed for as short a time as possible. Do not remove nodes from a live system unless replacement parts are available.

Steps

1. Rotate the power cable retention bail to the left (right for top power supply). Disconnect the power cable from the power supply.

The following figure shows an AC power supply.

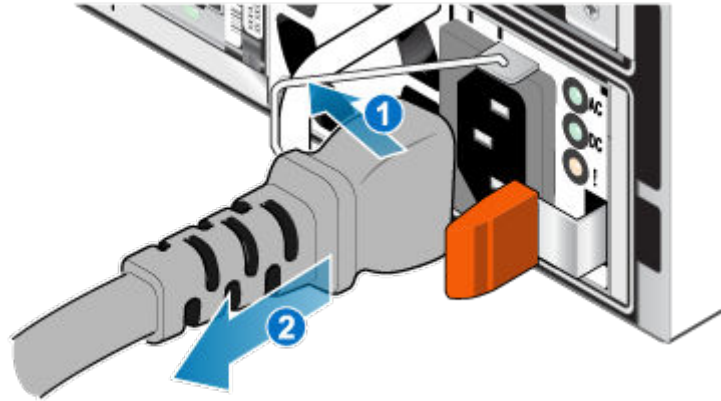

Figure 89. Removing the power cable

2. Disconnect the network and all other cables from the back of the I/O modules and network ports on the node.

i **NOTE:** Label the cables before you remove them.

i **NOTE:** Do not remove any cables from the other node.

3. If the node has a node ID plug on the node handle, remove the node ID plug.

4. Pull the orange release trigger while gently pushing in on the node.

The hook disengages from the locking mechanism, and the release tab slides out.

i **NOTE:** The node comes completely out of the chassis. Be prepared to support the node to avoid dropping it.

i **NOTE:** The release trigger and handle for node B is on the upper left. The release trigger and handle for node A is on the bottom right.

⚠ CAUTION: Removing the incorrect node leads to loss of system power and cached data will be lost.

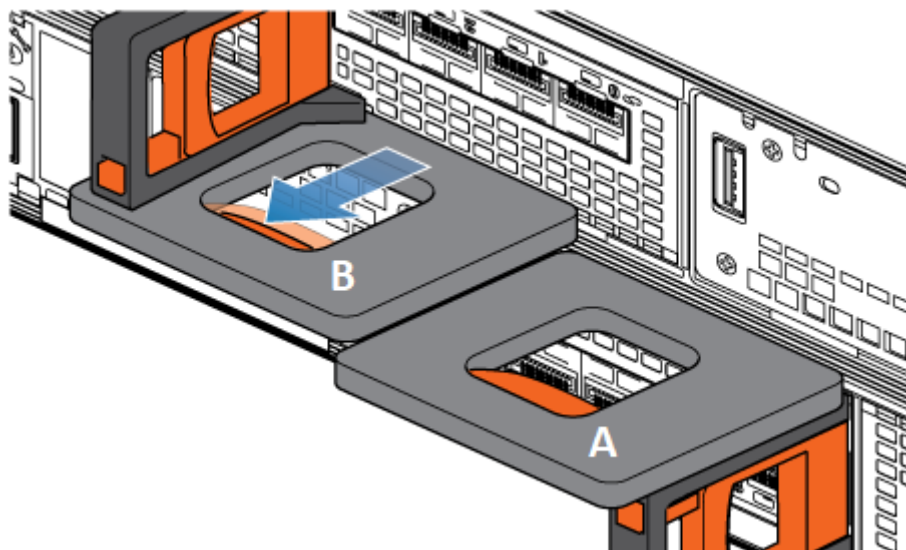

Figure 90. Disengaging the locking mechanism for node B

5. Before removing the node, ensure that the wire bail is properly secured to the power supply cable of the other node to prevent accidental loss of power and cache.
6. Use the release handle to pull the node outward enough to grasp the sides with both hands. Then, with both hands supporting the node, pull the node fully out of the enclosure.

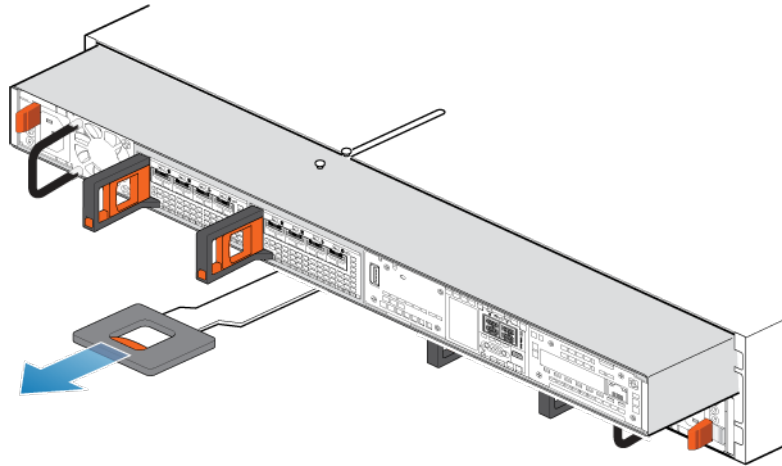

Figure 91. Removing the node

7. Place the node on a clean, flat, static-free work surface.

Remove the top cover from the node

Steps

1. While pushing down the two blue release buttons, slide the top cover towards the rear of the system, until it stops.
2. Lift the top cover upward, and remove it from the node.

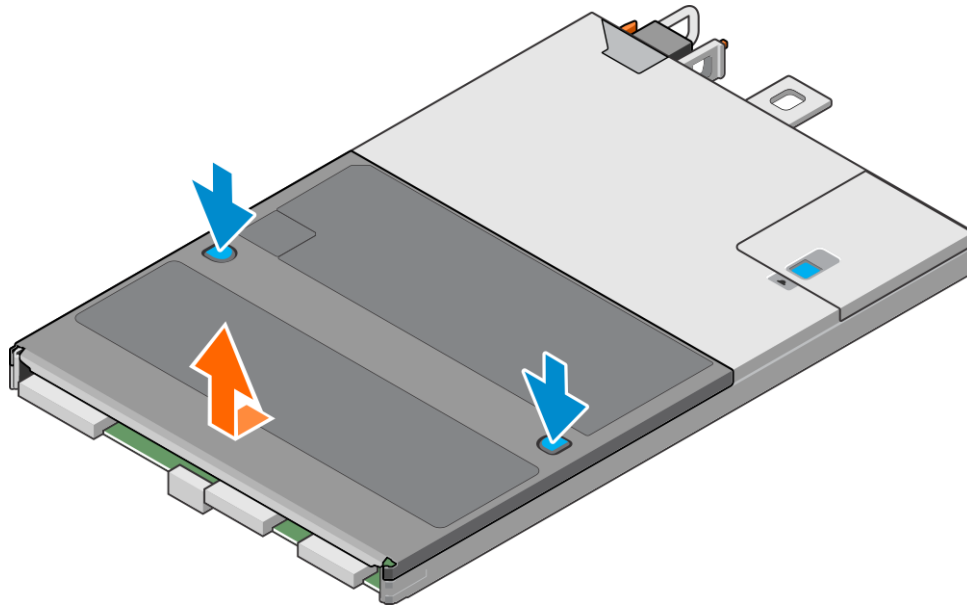

Figure 92. Removing the top cover

Remove the internal M.2 boot module

Steps

1. Gently pull straight up on the blue pull tab to release the internal M.2 boot module from the motherboard.

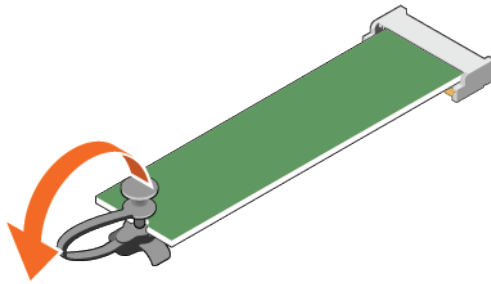

Figure 93. Releasing the internal M.2 boot module from the motherboard

2. Touching only the outside edges of the internal M.2 boot module, lift the end of the internal M.2 boot module to a slight angle, and then remove it from the slot on the motherboard.

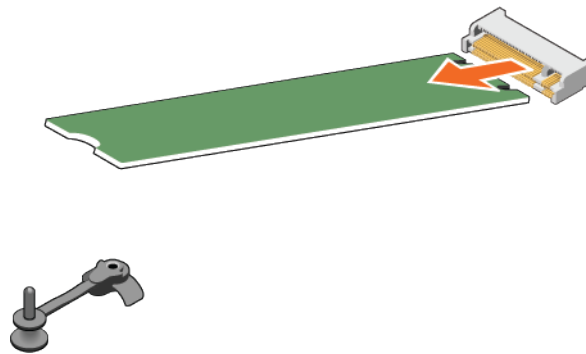

Figure 94. Removing the internal M.2 boot module

Install the internal M.2 boot module

Steps

1. Touching only the outside edges of the internal M.2 boot module, place the internal M.2 boot module into the slot on the motherboard.

NOTE: The side of the internal M.2 boot module with the barcodes should be facing up.

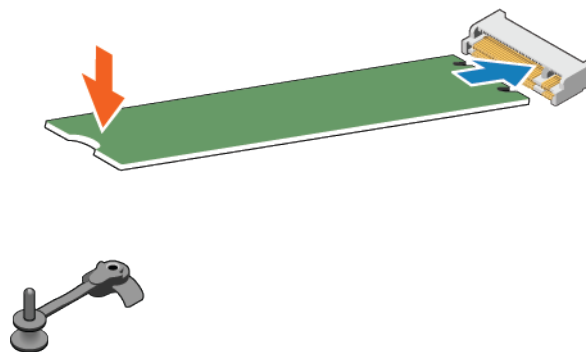

Figure 95. Placing the internal M.2 boot module

2. Connect the blue pull tab to the blue connector on the motherboard.

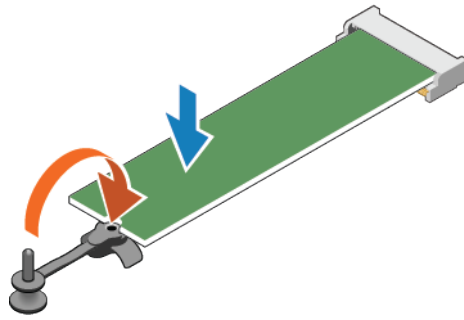

Figure 96. Connecting the internal M.2 boot module to the motherboard

Install the top cover on the node

Steps

1. Position the top cover over the node and align it with the slots in the sides at the rear of the node.
2. Pull the top cover forward to secure it in place.

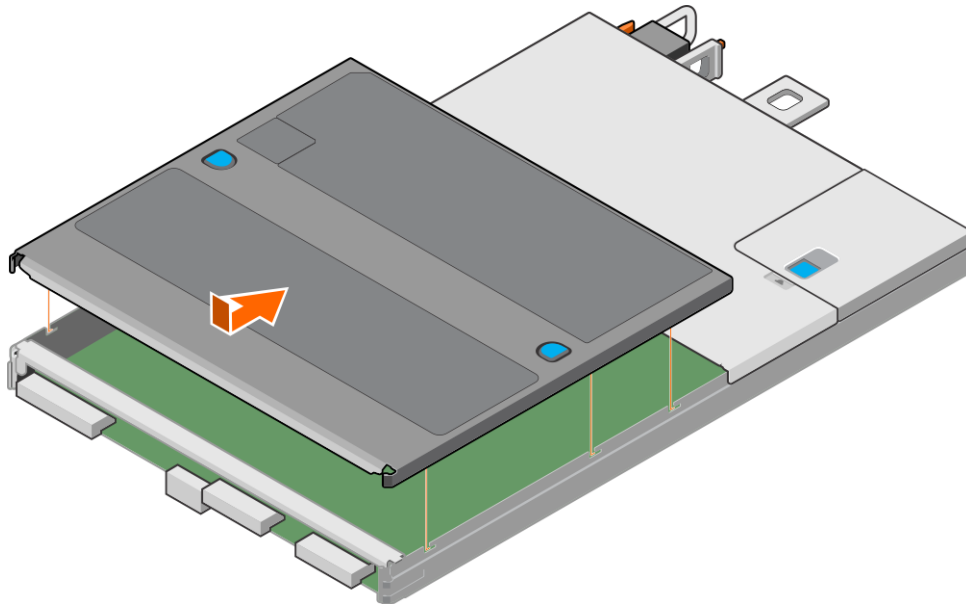

Figure 97. Installing the top cover

Install the node

Steps

1. Align the pins on the top of the node with the grooves on the top of the chassis.
2. Slide the node into the chassis until it stops, about halfway in.

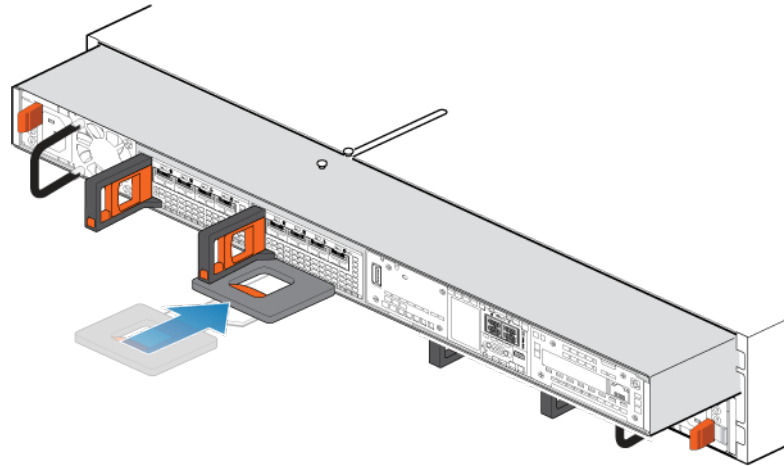

Figure 98. Sliding the node halfway into the chassis

3. Pull the black release tab out completely, and slide the rest of the node back into the chassis. The black release tab slides back into the system as it is inserted.

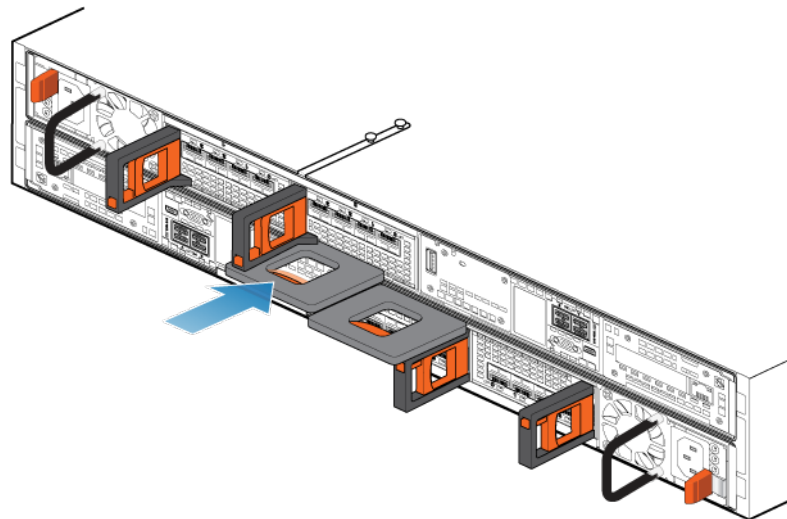

Figure 99. Installing the node

4. Reconnect the back-end cables and the cables to the I/O modules and network ports.
5. Pull the orange release trigger and push in gently to re-engage the locking mechanism. If the black release tab comes out when pulled, the locking mechanism is not engaged.
6. If the node came with a node ID plug, push the node ID plug onto the node handle.
7. Plug in the power cable.

Reimage the new internal M.2 boot module

Run the `svc_repair` command to begin the reimage to the new internal M.2 boot module.

About this task

- NOTE:** Do not run `svc_repair` before inserting the node. Run this command only after you have inserted the node. The node begins powering on when you have fully inserted it into the system.

Steps

1. Immediately after inserting the node, return to your SSH connection and run the `svc_repair` command from the surviving node.

NOTE: Run the command immediately after inserting the node to prevent any possibility of a time out issue.

The reimage procedure takes approximately 40 to 50 minutes to complete.

2. Review the output of the `svc_repair` command. The output provides useful information as the procedure runs, so allow the session to remain open so you can monitor the progress. The following output is an example. Your output may differ depending on which node is being reimaged.

```
SVC:cyc@CHXXXXX-A ~]$ svc_repair
PLEASE READ CAREFULLY!!! Requested operation will reformat peer node, all data will
be removed
Print 'YES' (All caps) if you want to continue recovery:
YES

CSU - initiating peer recovery. running on node A, recovering node B (Your message
may differ)
CSU - creating grub config
CSU - starting recovery container (afeoscyc-mw.cec.lab.emc.com/centos7/
recovery:v7.6.1327915), and booting peer node from PXE
CSU - sending power cycle command to peer
CSU - installation started, waiting for node to become reachable by ping, please be
patient, this might take a long time
CSU - still waiting for ping...
" " " " "
CSU - still waiting for ping...
CSU - peer node is reachable, starting health verification
CSU - waiting for node to answer via ssh, and checking installation flag (retry 10
out of 10)
CSU - waiting for node to answer via ssh, and checking installation flag (retry 9 out
of 10)
CSU - installation flag detected on peer node, reimage successfully performed
CSU - verifying peer is healthy, please wait...
" " " " "
CSU - verifying peer is healthy, please wait...
CSU - SUCCESS: node is healthy and ready for use!
=====
Successfully finished peer recovery - peer node is healthy
```

Next steps

If the `svc_repair` command fails, run it a second time. If the reimage fails again, contact your service provider.

```
FAILED to recover peer - manual intervention required
=====
Error 1: Reimaging of peer node failed - check journalctl for details
```

Verify the operation of a replacement internal M.2 boot module

Steps

1. From PowerStore Manager, select **Hardware > Appliances**.
2. Select the appliance where you replaced the internal M.2 boot module.
3. On the **Components** card, under **Internal View**, expand the node that includes the internal M.2 boot module, and then select the relevant **InternalM.2BootModule**.

The status of the replacement internal M.2 boot module should read `Healthy`. If the status is still `Faulted`, wait a few minutes and refresh PowerStore Manager. If the status does not change, ensure that the internal M.2 boot module is correctly seated, or contact your service provider.

Return a faulted part

About this task

For US customers, return defective material within five business days. For International customers, return defective material within 10 business days. The materials required to return your defective part are supplied with the good part shipment.

Steps

1. Package the faulted part in the shipping box that contained the replacement part.
2. Ship the failed part to your service provider as described in the instructions that were included with the replacement part.
3. For more information about returning customer-replaceable parts:
 - a. Open PowerStore Manager.
 - b. Click **Settings** on the upper right of the screen.
 - c. Click **General Support**.
 - d. Under **Drives, Power Supplies, and Other Parts**, click **Return Part**.
 - e. If your screen does not show the Return Part link, contact your service provider for instructions.

NVMe expansion enclosure service procedures

The NVMe expansion enclosure contains customer-replaceable components. Follow these procedures to safely replace a failed component.

 **NOTE:** Review the information in [Safety precautions for handling replaceable units](#) before handling replaceable parts.

Topics:

- [Replace a faulted drive in an NVMe expansion enclosure](#)
- [Add a drive in an NVMe expansion enclosure](#)
- [Replace a power supply module in an NVMe expansion enclosure](#)
- [Replace a fan module in an NVMe expansion enclosure](#)
- [Replace a Clock Distribution Board in an NVMe expansion enclosure](#)
- [Replace an Access Module in an NVMe expansion enclosure](#)
- [Replace a data interface board in an NVMe expansion enclosure](#)
- [Replace a dual inline memory module \(DIMM\)](#)

Replace a faulted drive in an NVMe expansion enclosure

Take the following actions to remove a faulted drive from an NVMe expansion enclosure and install a replacement drive.

 **NOTE:** If you are proactively replacing multiple drives, use the Proactive Drive Replacement procedure available in SolVe.

Identify a faulted drive from PowerStore Manager

Before you replace a drive, ensure that you have identified its location within the system. Using PowerStore Manager, you can identify and locate a faulted drive.

Steps

1. From PowerStore Manager, select **Hardware**.
2. Select the appliance that includes the drive that you need to replace.
3. On the **Components** card, under **Drives**, expand **ExpansionEnclosure** and select the faulted drive.
Faulted parts appear in red in the image of the system, and report a status of `Failed` in the **State** field.
4. Click **Blink LED**.
The amber fault light on the drive starts blinking.

Removing the front bezel

About this task

 **NOTE:** Remove the front bezel of the expansion enclosure to gain access to the drives. The bezel is required for EMI compliance when the enclosure is powered up. Remove it only to replace or add a drive.

Steps

1. If the bezel has a lock, insert the key that shipped with your enclosure into the lock, and turn the key to unlock the bezel.
2. Press the two latch buttons on the bezel surface to release the bezel from the cabinet.
3. Pull the bezel off the cabinet, and put it on a clean, static-free surface.

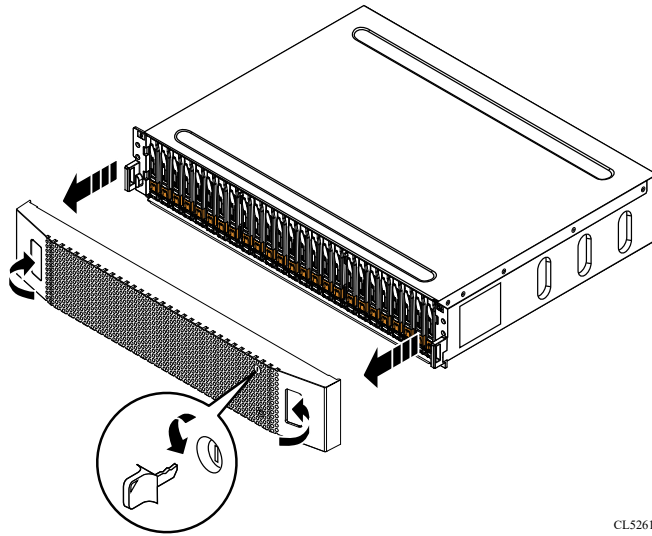

CL5261

Figure 100. Removing the front bezel

Remove a faulted drive

Steps

1. Check PowerStore Manager to ensure that it is not displaying an event banner indicating that drives should not be removed.
2. Locate the drive with the blinking amber LED fault light.
3. Push down the orange button to release the latch.
4. Remove the drive from the slot.

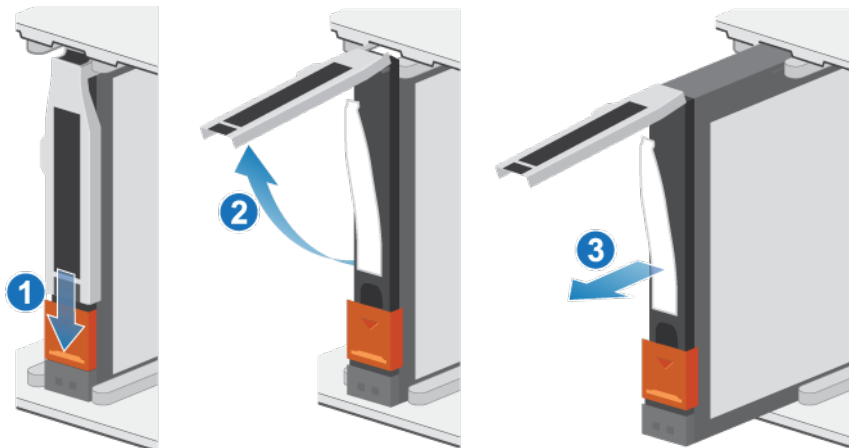

Figure 101. Removing a drive

5. Place the drive on a static-free surface.

Installing a drive

Steps

1. Align the drive with the guides in the slot.
2. With the latch fully opened, gently push the drive into the slot.
The latch begins to rotate downward when it meets the enclosure.
3. Push the orange button until the drive is fully seated in the slot.
4. Push the latch down until it locks into place.

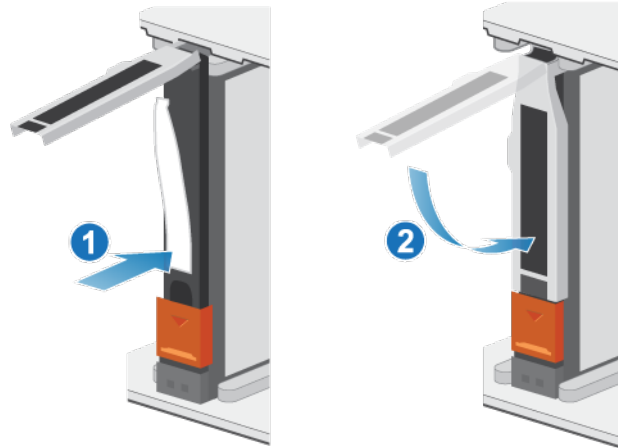

Figure 102. Installing a drive

The activity light flashes to indicate that the spin-up sequence has begun.

Installing the front bezel

Steps

1. Align the bezel with the enclosure.
2. Gently push the bezel into place on the cabinet until it latches.
3. If the bezel has a keylock, lock the bezel with the provided key.

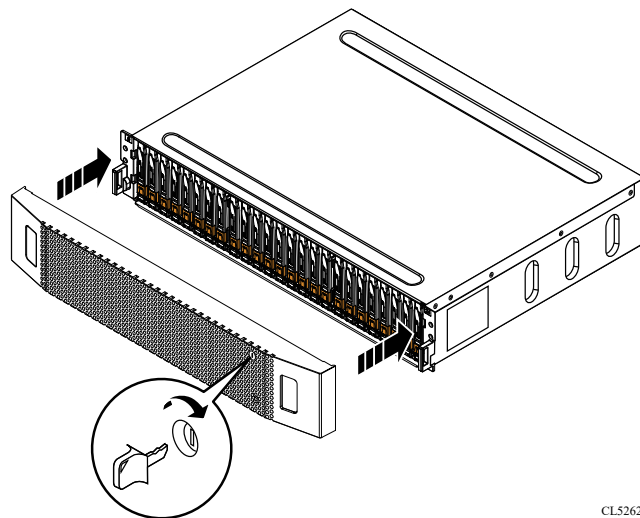

CL5262

Figure 103. Installing the bezel

Verify the operation of a replacement drive

Steps

1. From PowerStore Manager, select **Hardware**.
2. Select the appliance where you replaced the drive.
3. On the **Components** card, under **Drives**, expand **ExpansionEnclosure** and select the drive.
The status of the replacement drive should read `Healthy`. If the status is still `Failed`, wait a few minutes and refresh PowerStore Manager. If the status does not change, ensure that the drive is correctly seated, or contact your service provider.
4. Click **Stop Blink LED**.

Return a faulted part

About this task

For US customers, return defective material within five business days. For International customers, return defective material within 10 business days. The materials required to return your defective part are supplied with the good part shipment.

Steps

1. Package the faulted part in the shipping box that contained the replacement part.
2. Ship the failed part to your service provider as described in the instructions that were included with the replacement part.
3. For more information about returning customer-replaceable parts:
 - a. Open PowerStore Manager.
 - b. Click **Settings** on the upper right of the screen.
 - c. Click **General Support**.
 - d. Under **Drives, Power Supplies, and Other Parts**, click **Return Part**.
 - e. If your screen does not show the Return Part link, contact your service provider for instructions.

Add a drive in an NVMe expansion enclosure

Take the following actions to add a new drive to an NVMe expansion enclosure.

Removing the front bezel

About this task

 **NOTE:** Remove the front bezel of the expansion enclosure to gain access to the drives. The bezel is required for EMI compliance when the enclosure is powered up. Remove it only to replace or add a drive.

Steps

1. If the bezel has a lock, insert the key that shipped with your enclosure into the lock, and turn the key to unlock the bezel.
2. Press the two latch buttons on the bezel surface to release the bezel from the cabinet.
3. Pull the bezel off the cabinet, and put it on a clean, static-free surface.

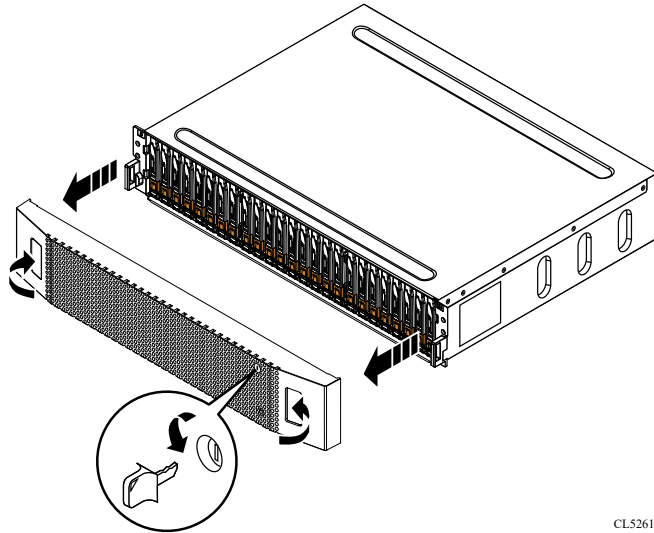

CL5261

Figure 104. Removing the front bezel

Remove a drive filler module

Steps

1. Insert your finger into the cutout on the drive filler module.
2. Pull the filler module out of the slot.

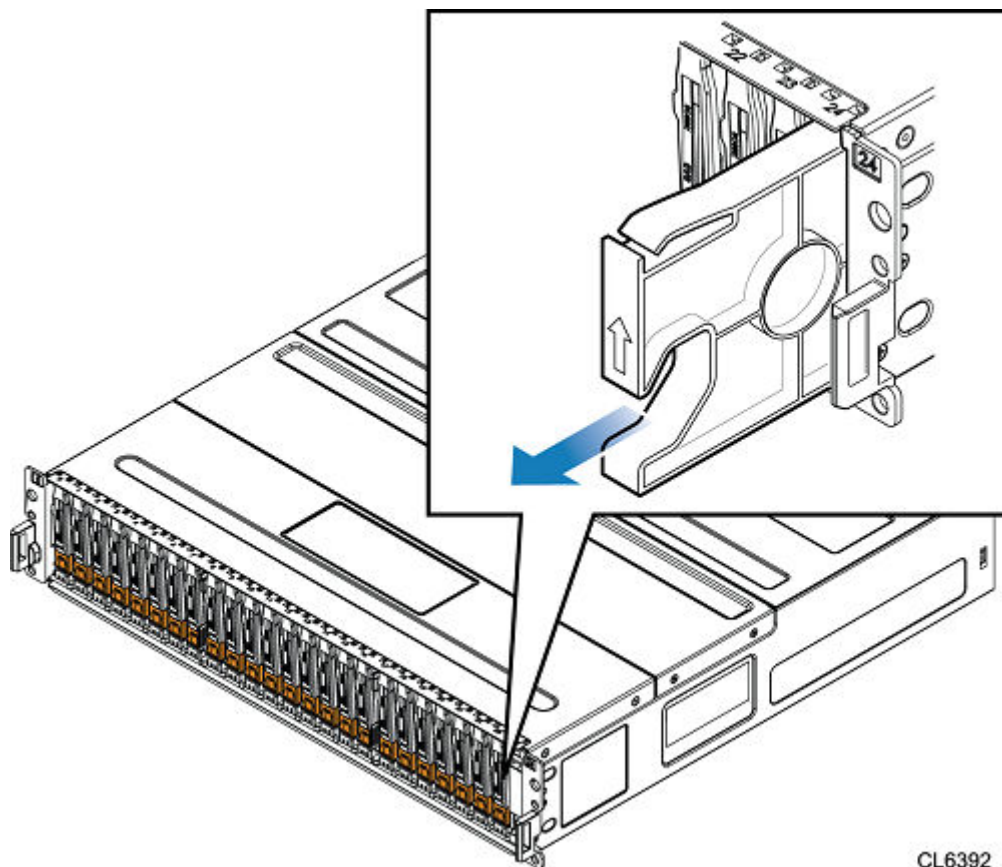

CL6392

Figure 105. Removing a drive filler module

Installing a drive

About this task

NOTE: If you are installing multiple drives in a system that is powered up, wait at least 10 seconds before sliding the next drive into position, but do not exceed 2 minutes. This will allow the system to determine the best RAID width.

NOTE: Drives must be installed from left-to-right starting with the first available slot.

Steps

1. Align the drive with the guides in the slot.
2. With the latch fully opened, gently push the drive into the slot.
The latch begins to rotate downward when it meets the enclosure.
3. Push the orange button until the drive is fully seated in the slot.
4. Push the latch down until it locks into place.

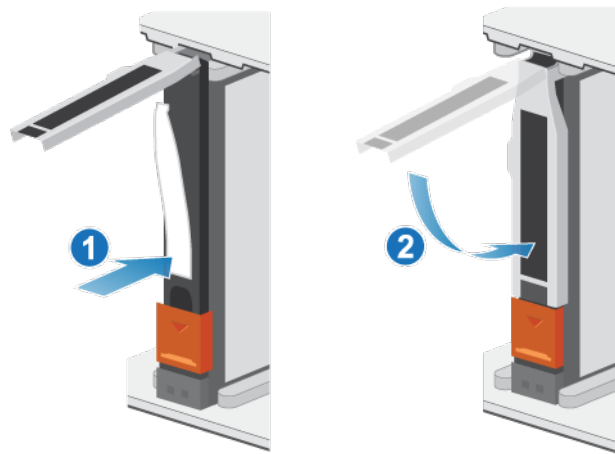

Figure 106. Installing a drive

The activity light flashes to indicate that the spin-up sequence has begun.

Installing the front bezel

Steps

1. Align the bezel with the enclosure.
2. Gently push the bezel into place on the cabinet until it latches.
3. If the bezel has a keylock, lock the bezel with the provided key.

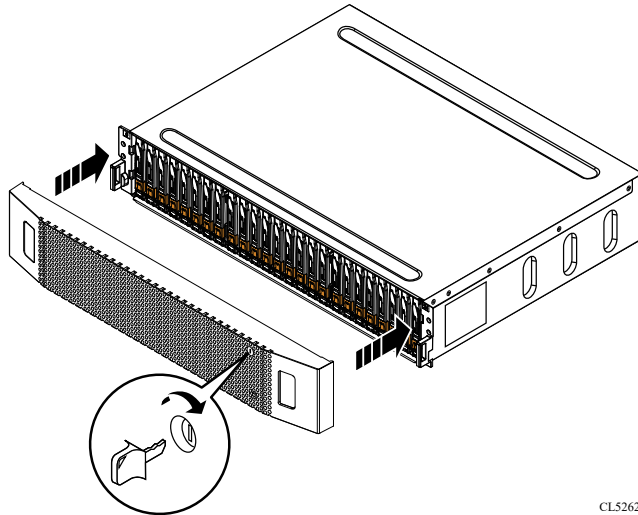

CL5262

Figure 107. Installing the bezel

Verify the operation of an added drive

Steps

1. From PowerStore Manager, select **Hardware**.
2. Select the appliance where you added the drive.
3. On the **Components** card, under **Drives**, expand **ExpansionEnclosure** and select the drive.
The status of the drive should read `Healthy`. If the status is still `Faulted`, wait a few minutes and refresh PowerStore Manager. If the status does not change, ensure that the drive is correctly seated, or contact your service provider.

Replace a power supply module in an NVMe expansion enclosure

Take the following actions to remove the faulted power supply module from the NVMe expansion enclosure and install a replacement power supply.

Identify a faulted power supply from PowerStore Manager

Before you replace a power supply, use PowerStore Manager to identify its location within the system.

Steps

1. From PowerStore Manager, select **Hardware**.
2. Select the appliance that includes the power supply that you need to replace.
3. On the **Components** card, under **Rear View**, expand **ExpansionEnclosure**.
4. Expand the node that includes the power supply, and then select **PSU0**.
Faulted parts appear in red in the image of the system, and report a status of `Faulted` in the **State** field.

NVMe expansion enclosure power supply LEDs

Use the fault LEDs to identify the faulted part.

NOTE: The power supplies in the NVMe expansion enclosure are installed upside down.

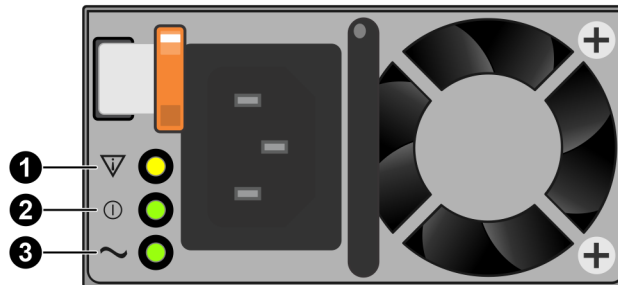

Figure 108. NVMe expansion enclosure power supply LEDs

Table 10. NVMe expansion enclosure power supply LEDs

LED	Location	State	Description
Fault	1	Solid amber	Power supply or backup fault. Check the cable connection.
		Off	No fault.
DC power (output)	2	Green	DC power is on.
		Off	DC power is off. Verify the source power.
AC power (input)	3	Green	AC power is on.
		Off	AC power is off. Verify the source power

Remove a power supply

About this task

The power supplies in the NVMe expansion enclosure are installed upside down.

NOTE: You do not need to power off the system to remove a power supply.

Steps

1. Rotate the power cable retention bail to the left. Remove the power cable from the power supply.

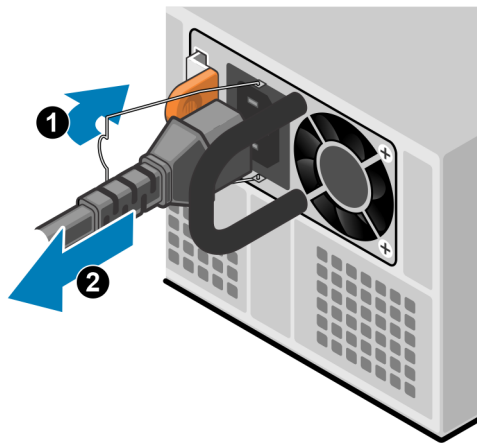

Figure 109. Removing the power cable

2. Push and hold the orange release tab to the left and grasp the power supply by its handle. Remove the power supply by pulling it from the node.

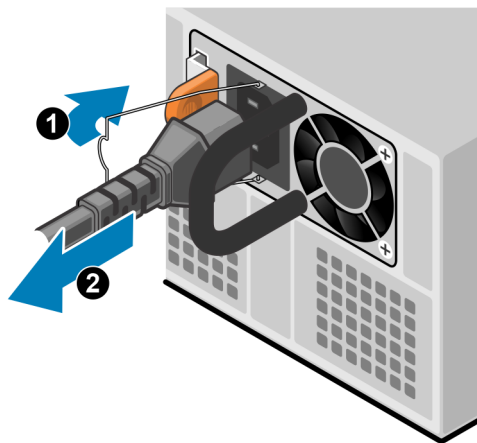

Figure 110. Removing a power supply

Install a power supply

About this task

The power supplies in the NVMe expansion enclosure are installed upside down.

Steps

1. Align the power supply with the slot in the node. The power cable retention bail is on the left.
2. Push the power supply into the node until it clicks into place.

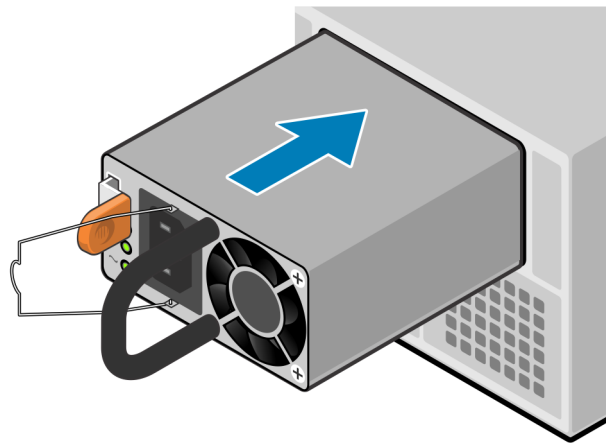

Figure 111. Installing a power supply

3. Connect the power cable to the power supply and secure the cord with the retention bail at the connector.

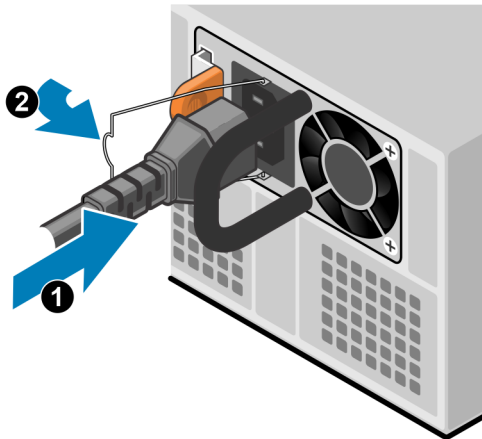

Figure 112. Inserting the power cable

Verify the operation of a replacement power supply

Steps

1. From PowerStore Manager, select **Hardware**.
2. Select the appliance where you replaced the power supply.
3. On the **Components** card, under **Rear View**, expand **ExpansionEnclosure**.
4. Expand the node that includes the power supply, and then select **PSU0**.

The status of the replacement power supply should read `Healthy`. If the status is still `Faulted`, wait a few minutes and refresh PowerStore Manager. If the status does not change, ensure that the power supply is correctly seated, or contact your service provider.

Return a faulted part

About this task

For US customers, return defective material within five business days. For International customers, return defective material within 10 business days. The materials required to return your defective part are supplied with the good part shipment.

Steps

1. Package the faulted part in the shipping box that contained the replacement part.
2. Ship the failed part to your service provider as described in the instructions that were included with the replacement part.
3. For more information about returning customer-replaceable parts:
 - a. Open PowerStore Manager.
 - b. Click **Settings** on the upper right of the screen.
 - c. Click **General Support**.
 - d. Under **Drives, Power Supplies, and Other Parts**, click **Return Part**.
 - e. If your screen does not show the Return Part link, contact your service provider for instructions.

Replace a fan module in an NVMe expansion enclosure

Take the following actions to remove the faulted fan module from the NVMe expansion enclosure and install a replacement fan.

Identify a faulted fan module from PowerStore Manager

Before you replace a fan module, ensure that you have identified its location within the system. Using PowerStore Manager, you can identify and locate a faulted fan module.

Steps

1. From PowerStore Manager, select **Hardware > Appliances**.
2. Select the appliance that includes the fan module that you need to replace.
3. On the **Components** card, under **Internal View**, expand the node that includes the fan module, and then select the relevant **FanModule**.

Faulted parts appear in red in the image of the system, and report a status of `Faulted` in the **State** field.

Remove a fan module

Steps

1. Pull the expansion enclosure from the rack until the system cover is accessible.
2. Lift open the system cover.



CAUTION: Do not leave the system cover open for more than two minutes. If you need more time, close the cover and allow the system temperature to stabilize before proceeding.

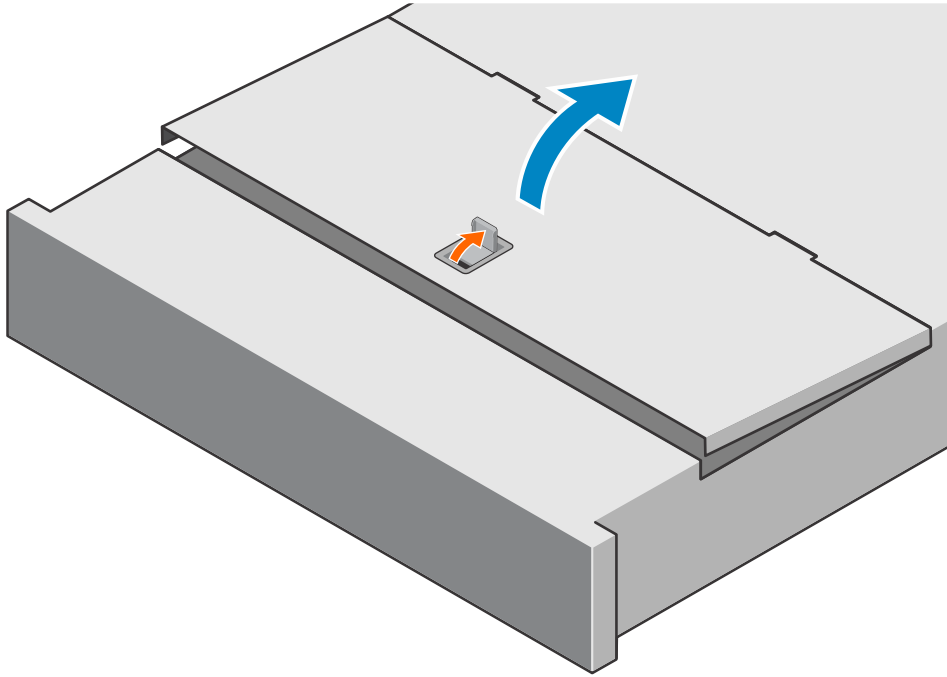

Figure 113. Lifting the system cover

3. Squeeze the orange release tabs on the fan module.
4. Lift the fan module away from the system.

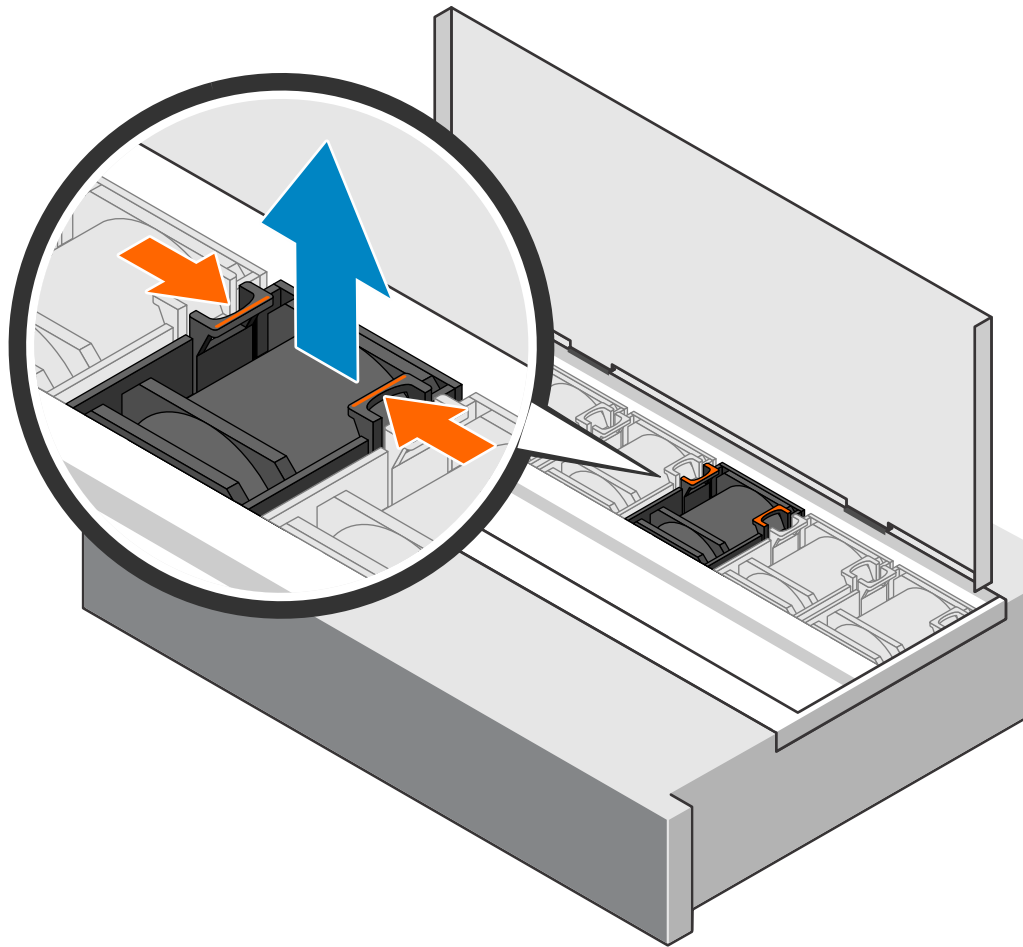

Figure 114. Removing a fan module

Install a fan module

Steps

1. Push the fan module into the empty slot.

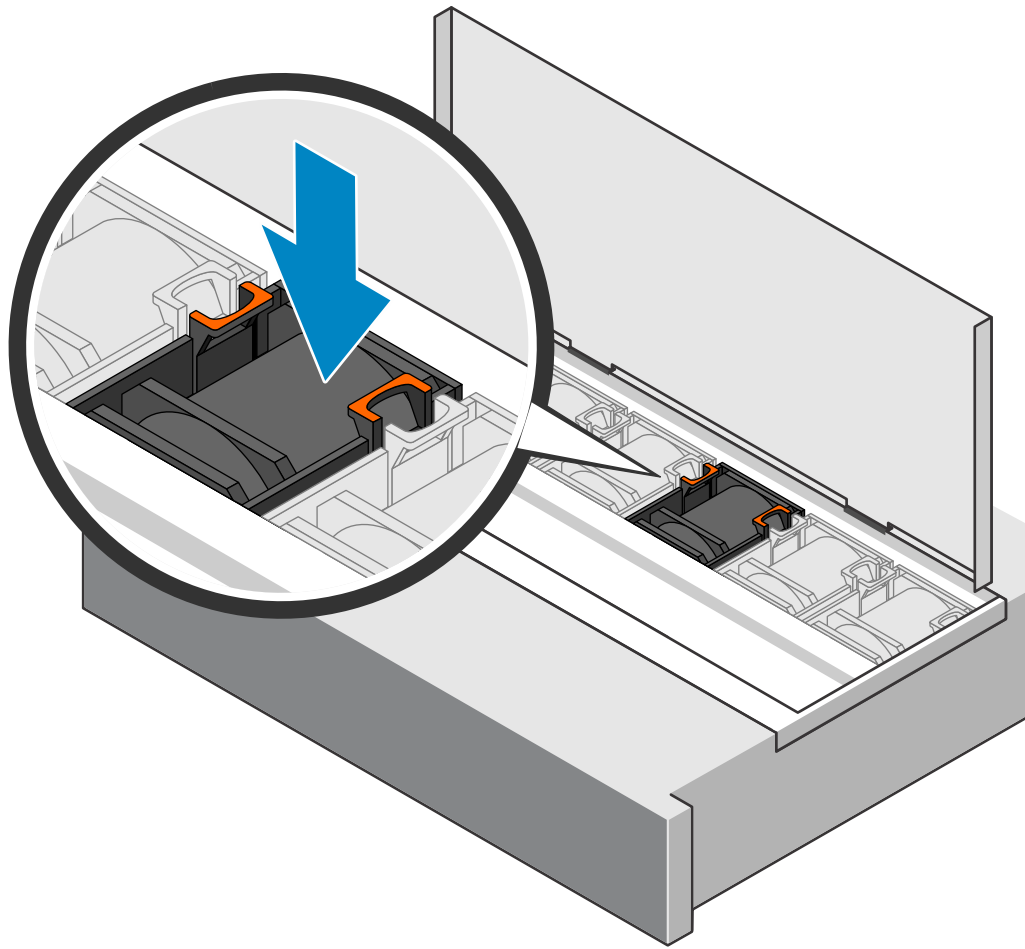

Figure 115. Installing a fan module

2. Close the system cover.

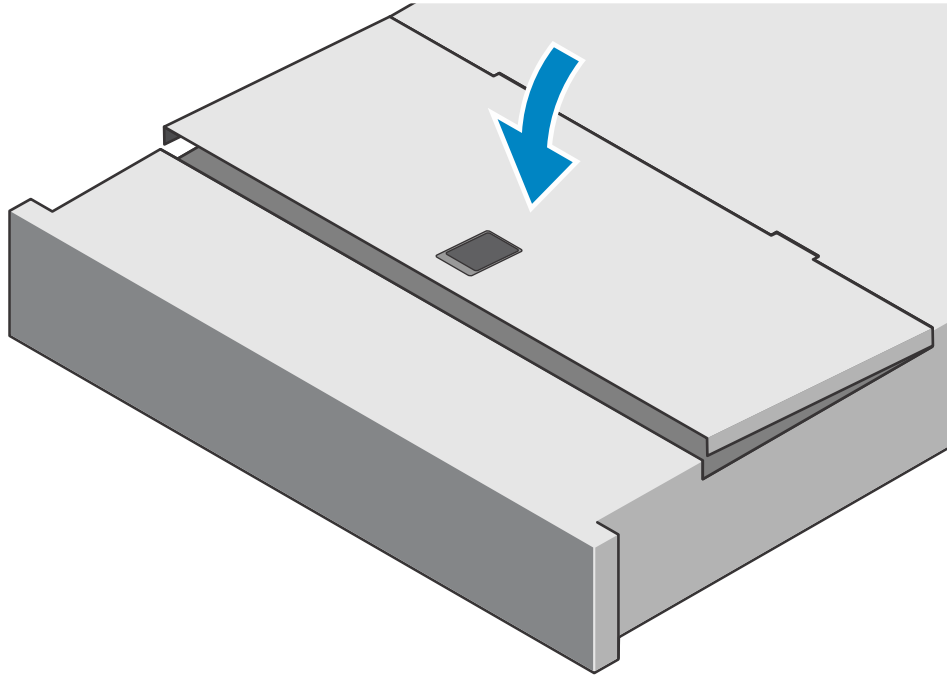

Figure 116. Closing the system cover

3. Push the expansion enclosure into the rack.

Verify the operation of a replacement fan module

Steps

1. From PowerStore Manager, select **Hardware > Appliances**.
2. Select the appliance where you replaced the fan module.
3. On the **Components** card, under **Internal View**, expand the node that includes the fan module, and then select the relevant **FanModule**.

The status of the replacement fan module should read `Healthy`. If the status is still `Faulted`, wait a few minutes and refresh PowerStore Manager. If the status does not change, ensure that the fan module is correctly seated, or contact your service provider.

Return a faulted part

About this task

For US customers, return defective material within five business days. For International customers, return defective material within 10 business days. The materials required to return your defective part are supplied with the good part shipment.

Steps

1. Package the faulted part in the shipping box that contained the replacement part.
2. Ship the failed part to your service provider as described in the instructions that were included with the replacement part.
3. For more information about returning customer-replaceable parts:
 - a. Open PowerStore Manager.
 - b. Click **Settings** on the upper right of the screen.
 - c. Click **General Support**.
 - d. Under **Drives, Power Supplies, and Other Parts**, click **Return Part**.
 - e. If your screen does not show the Return Part link, contact your service provider for instructions.

Replace a Clock Distribution Board in an NVMe expansion enclosure

Take the following actions to remove the faulted Clock Distribution Board from the NVMe expansion enclosure and install a replacement Clock Distribution Board.

Identify a faulted Clock Distribution Board from PowerStore Manager

Before you replace a Clock Distribution Board, ensure that you have identified its location within the system. Using PowerStore Manager, you can identify and locate a faulted Clock Distribution Board.

Steps

1. From PowerStore Manager, select **Hardware**.
2. Select the appliance that contains the Clock Distribution Board that you need to replace.
3. On the **Components** card, under **Rear View**, expand **ExpansionEnclosure**.
4. Select the relevant **CDB**.
Faulted parts appear in red in the image of the system, and report a status of `Failed` in the **State** field.

Remove a Clock Distribution Board.

Steps

1. Pull the expansion enclosure from the rack until the system cover is accessible.
2. Lift open the system cover.



CAUTION: Do not leave the system cover open for more than two minutes. If you need more time, close the cover and allow the system temperature to stabilize before proceeding.

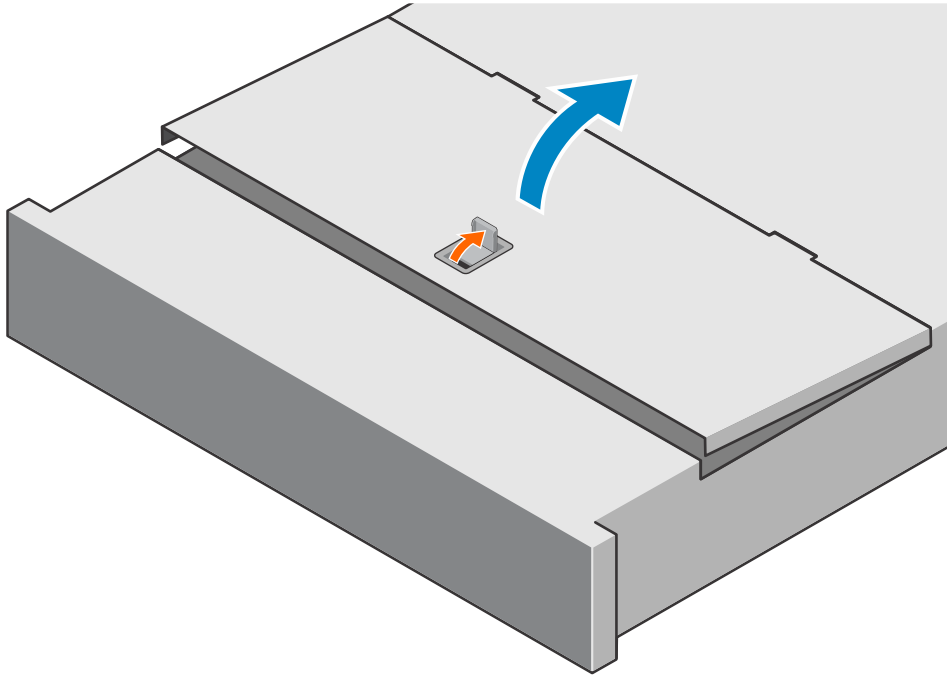

Figure 117. Lifting the system cover

3. Squeeze the orange release tabs on the Clock Distribution Board.
4. Slide the Clock Distribution Board toward the fans and then up out of the system.

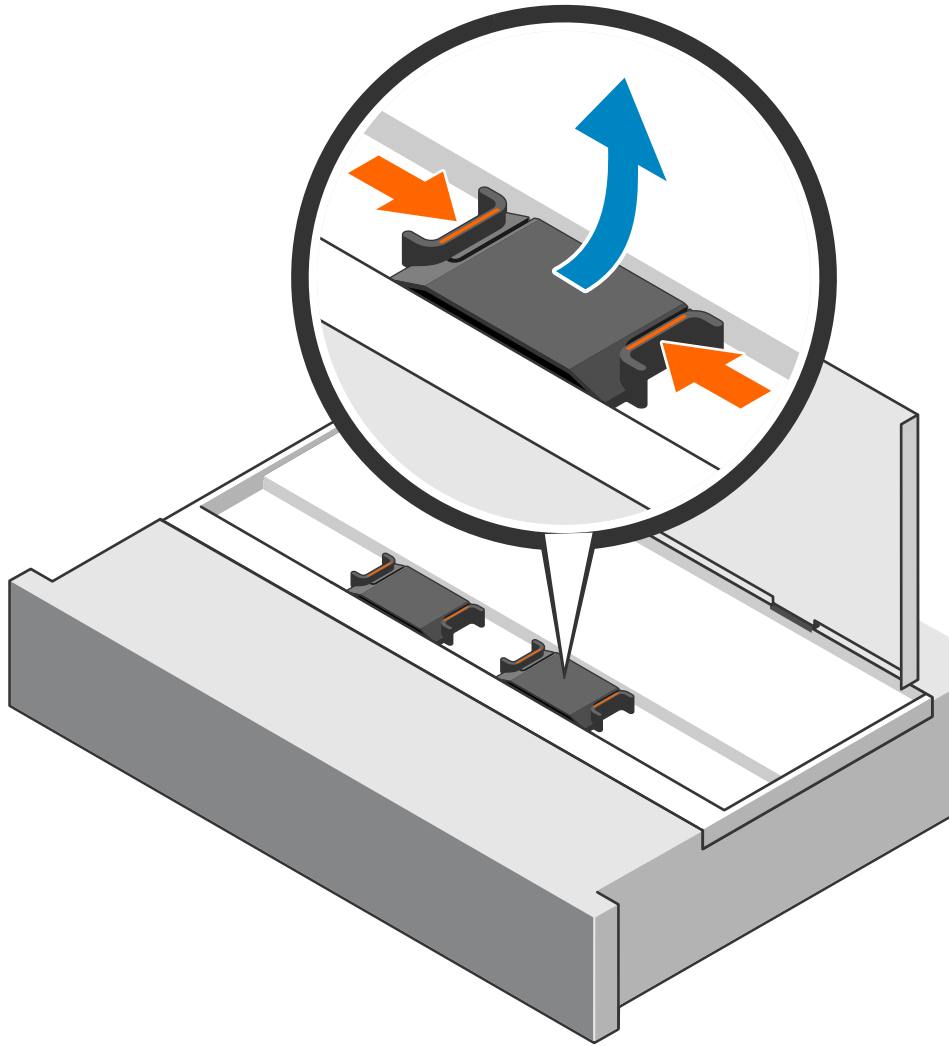

Figure 118. Removing the Clock Distribution Board

Install a Clock Distribution Board

Steps

1. Squeeze the orange tabs and align the Clock Distribution Board with the empty slot.
2. Push the Clock Distribution Board into the empty slot.

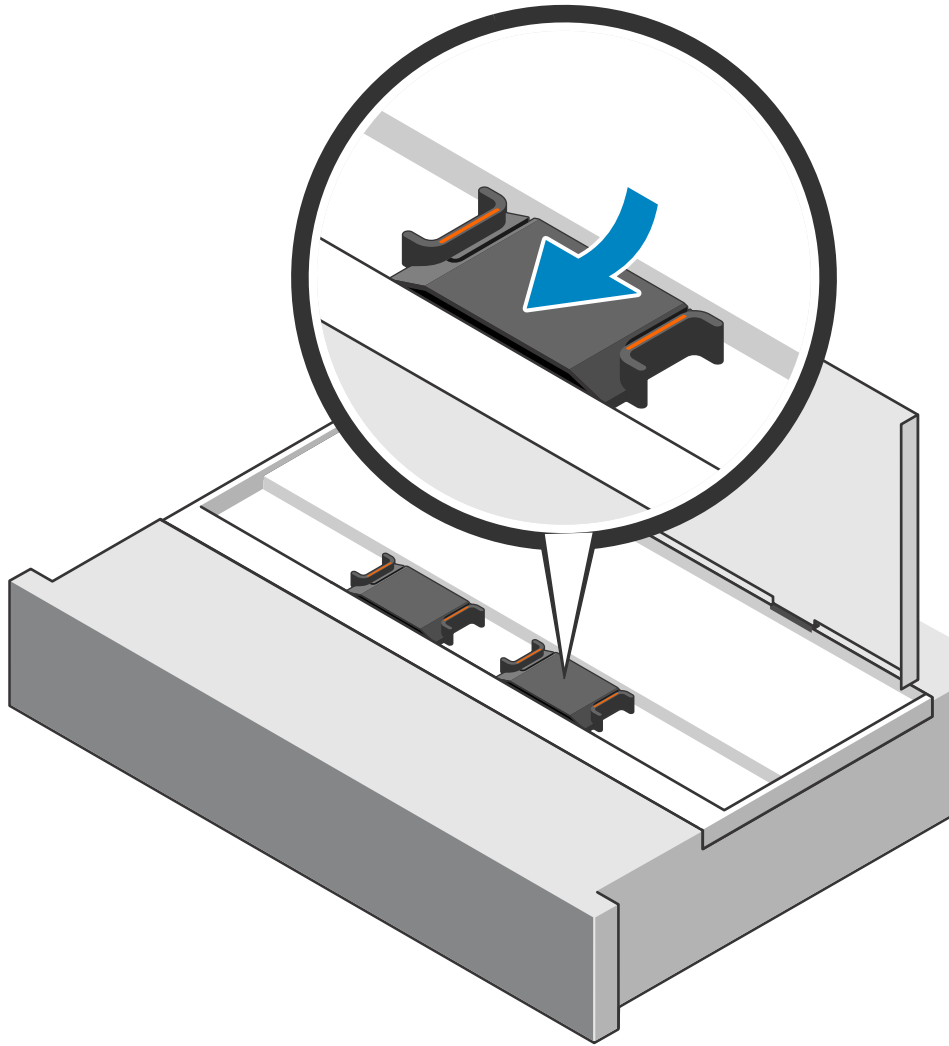

Figure 119. Installing the Clock Distribution Board

3. Close the system cover.

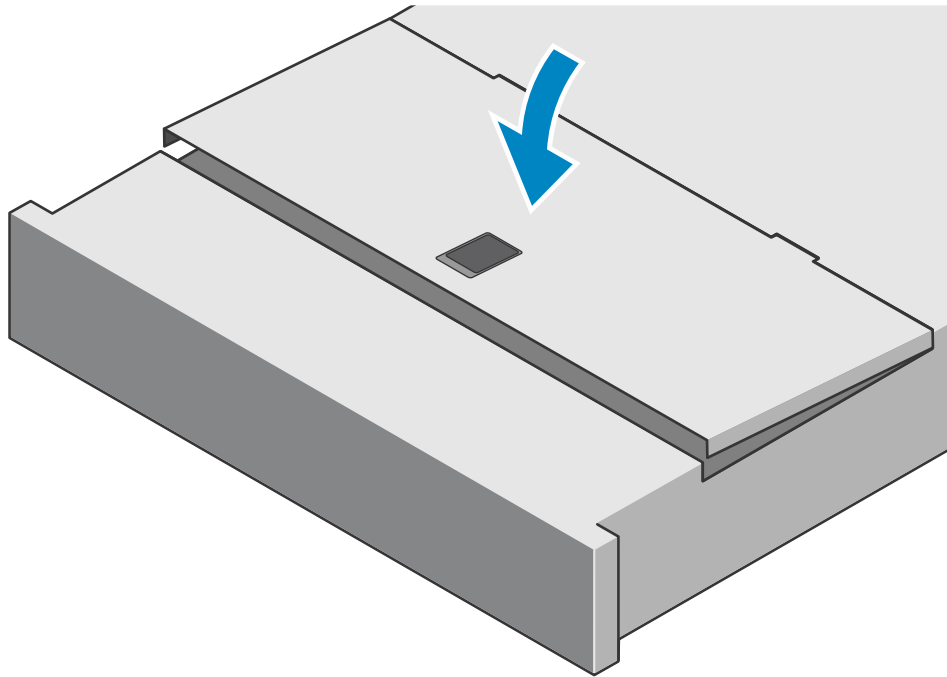

Figure 120. Closing the system cover

4. Push the expansion enclosure into the rack.

Verify the operation of a replacement Clock Distribution Board

Steps

1. From PowerStore Manager, select **Hardware**.
2. Select the appliance where you replaced the Clock Distribution Board.
3. On the **Components** card, under **Rear View**, expand **ExpansionEnclosure**.
4. Select the relevant Clock Distribution Board.

The status of the replacement Clock Distribution Board should read `Healthy`. If the status is still `Failed`, wait a few minutes and refresh PowerStore Manager. If the status does not change, ensure that the Clock Distribution Board is correctly seated, or contact your service provider.

Return a faulted part

About this task

For US customers, return defective material within five business days. For International customers, return defective material within 10 business days. The materials required to return your defective part are supplied with the good part shipment.

Steps

1. Package the faulted part in the shipping box that contained the replacement part.
2. Ship the failed part to your service provider as described in the instructions that were included with the replacement part.
3. For more information about returning customer-replaceable parts:
 - a. Open PowerStore Manager.
 - b. Click **Settings** on the upper right of the screen.
 - c. Click **General Support**.
 - d. Under **Drives, Power Supplies, and Other Parts**, click **Return Part**.
 - e. If your screen does not show the Return Part link, contact your service provider for instructions.

Replace an Access Module in an NVMe expansion enclosure

Take the following actions to remove the faulted Access Module from the NVMe expansion enclosure and install a replacement Access Module.

Identify a faulted Access Module from PowerStore Manager

Before you replace an Access Module, ensure that you have identified its location within the system. Using PowerStore Manager, you can identify and locate a faulted Access Module.

Steps

1. From PowerStore Manager, select **Hardware**.
2. Select the appliance that contains the Access Module that you need to replace.
3. On the **Components** card, under **Rear View**, expand **ExpansionEnclosure**.
4. Select the relevant **Access Module**.
Faulted parts appear in red in the image of the system, and report a status of `Faulted` in the **State** field.

Remove an Access Module

About this task

 **NOTE:** Access Module 1 is on the top of the NVMe expansion enclosure and Access Module 2 is on the bottom.

Steps

1. Label and remove the cables from the Access Module.
2. Press both orange buttons to release the Access Module latches.

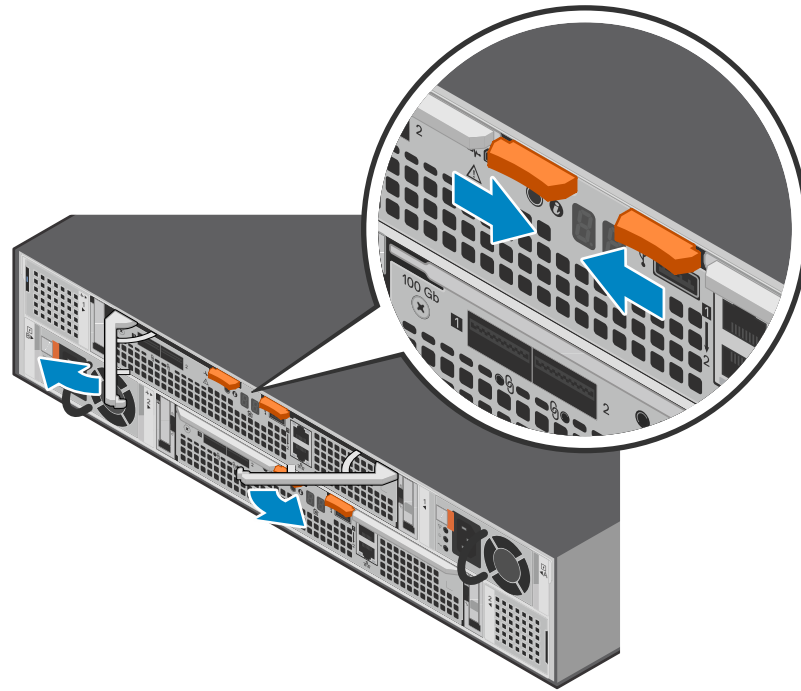

Figure 121. Releasing the Access Module

3. Pull the latches to remove the Access Module from the chassis.

i **NOTE:** The Access Module comes completely out of the chassis. In addition to holding the latches, be prepared to support the Access Module to avoid dropping it.

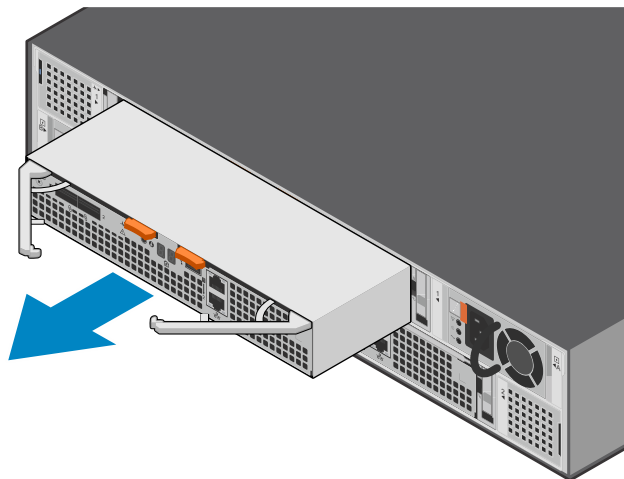

Figure 122. Removing the Access Module

Install an Access Module

Steps

1. Align the Access Module with the empty slot and carefully push it into the slot.

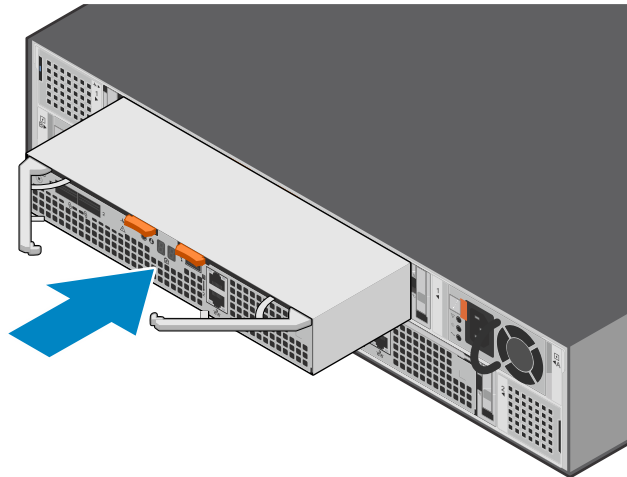

Figure 123. Installing the Access Module

2. Press in on the Access Module latches to lock them into place.

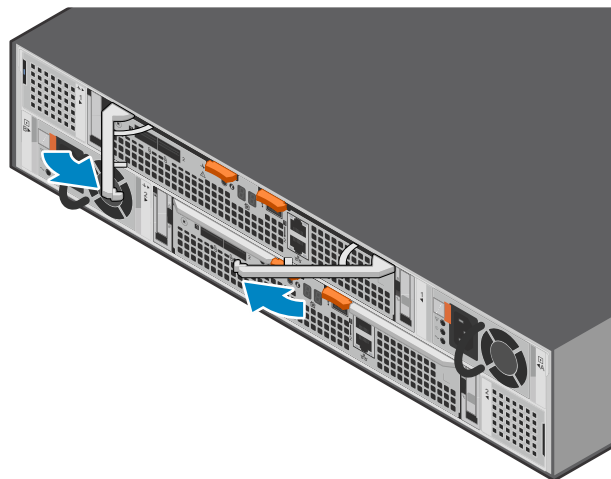

Figure 124. Locking the Access Module into place

3. Connect the cables to the Access Module.

Verify the operation of a replacement Access Module

Steps

1. From PowerStore Manager, select **Hardware**.
2. Select the appliance where you replaced the Access Module.
3. On the **Components** card, under **Rear View**, expand **ExpansionEnclosure**.
4. Select the relevant **Access Module**.

The status of the replacement Access Module should read `Healthy`. If the status is still `Faulted`, wait a few minutes and refresh PowerStore Manager. If the status does not change, ensure that the Access Module is correctly seated, or contact your service provider.

Return a faulted part

About this task

For US customers, return defective material within five business days. For International customers, return defective material within 10 business days. The materials required to return your defective part are supplied with the good part shipment.

Steps

1. Package the faulted part in the shipping box that contained the replacement part.
2. Ship the failed part to your service provider as described in the instructions that were included with the replacement part.
3. For more information about returning customer-replaceable parts:
 - a. Open PowerStore Manager.
 - b. Click **Settings** on the upper right of the screen.
 - c. Click **General Support**.
 - d. Under **Drives, Power Supplies, and Other Parts**, click **Return Part**.
 - e. If your screen does not show the Return Part link, contact your service provider for instructions.

Replace a data interface board in an NVMe expansion enclosure

Take the following actions to remove a faulted data interface board (DIB) from an NVMe expansion enclosure and install a replacement DIB.

Identify a faulted DIB from PowerStore Manager

Before you replace a DIB, ensure that you have identified its location within the system. Using PowerStore Manager, you can identify and locate a faulted DIB.

Steps

1. From PowerStore Manager, select **Hardware**.
2. Select the appliance that contains the DIB that you need to replace.
3. On the **Components** card, under **Rear View**, expand **ExpansionEnclosure**.
4. Select the relevant **DIB**.

Faulted parts appear in red in the image of the system, and report a status of `Faulted` in the **State** field.

Removing a DIB

Steps

1. Remove the Access Module as described in [Remove an Access Module](#).
2. Press down on both orange buttons to release the DIB latches.

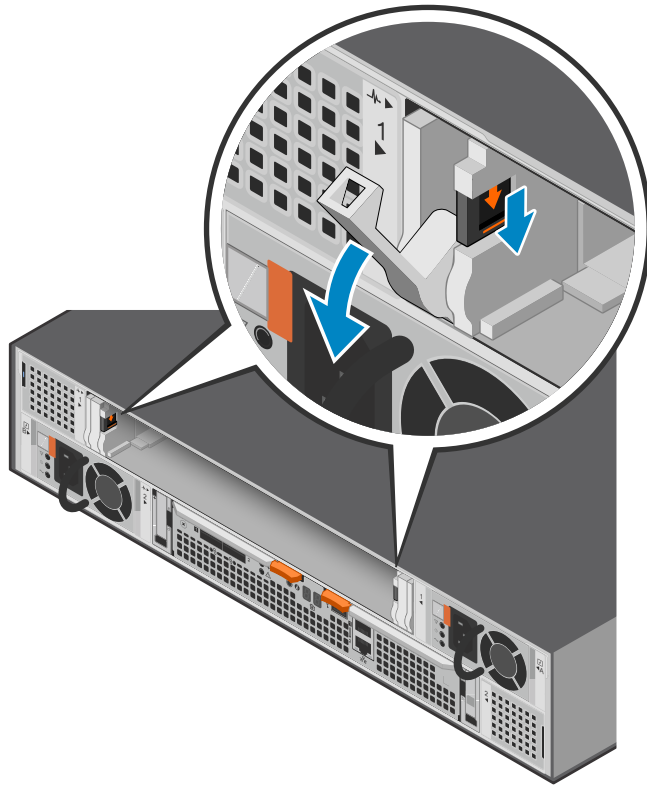

Figure 125. Releasing the DIB

3. Press down firmly on the latches, and then pull the latches to remove the DIB from the chassis.

i **NOTE:** The DIB comes completely out of the chassis. In addition to holding the latches, be prepared to support the DIB to avoid dropping it.

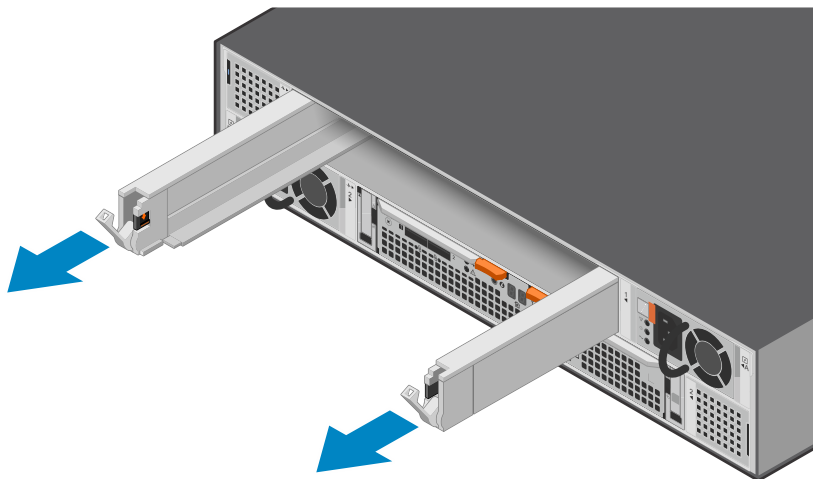

Figure 126. Removing the DIB

Replacing a DIB

Steps

1. Align the DIB with the empty slot and carefully push it into the slot until the latches are engaged and start to rise.

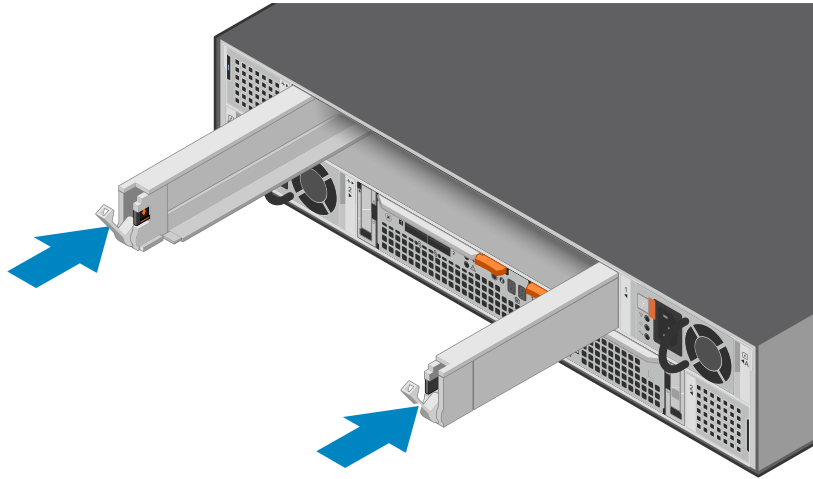

Figure 127. Installing the DIB

2. Press up on the DIB latches to lock them into place.

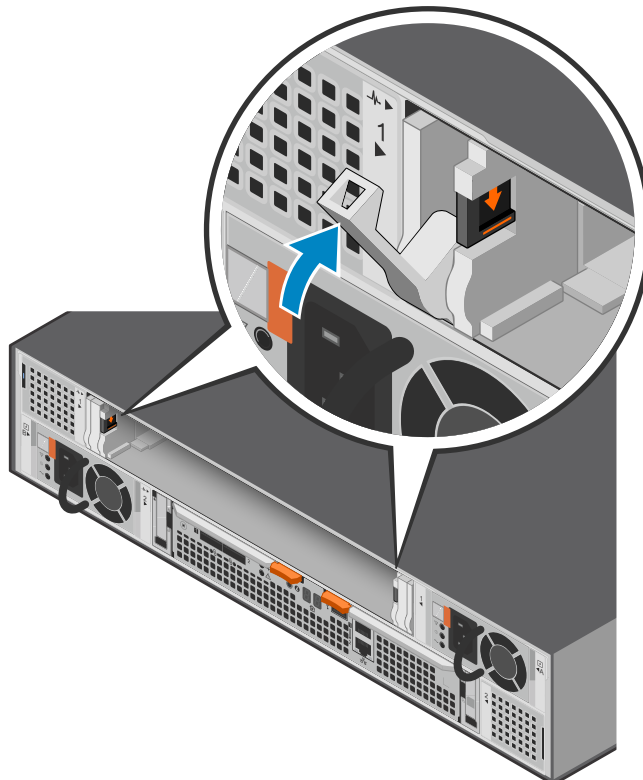

Figure 128. Locking the DIB into place

3. Replace the Access Module as described in [Install an Access Module](#).

Verify the operation of a replacement DIB

Steps

1. From PowerStore Manager, select **Hardware**.
2. Select the appliance where you replaced the DIB.
3. On the **Components** card, under **Rear View**, expand **ExpansionEnclosure**.
4. Select the relevant **DIB**.

The status of the replacement DIB should read `Healthy`. If the status is still `Failed`, wait a few minutes and refresh PowerStore Manager. If the status does not change, ensure that the DIB is correctly seated, or contact your service provider.

Return a faulted part

About this task

For US customers, return defective material within five business days. For International customers, return defective material within 10 business days. The materials required to return your defective part are supplied with the good part shipment.

Steps

1. Package the faulted part in the shipping box that contained the replacement part.
2. Ship the failed part to your service provider as described in the instructions that were included with the replacement part.
3. For more information about returning customer-replaceable parts:
 - a. Open PowerStore Manager.
 - b. Click **Settings** on the upper right of the screen.
 - c. Click **General Support**.
 - d. Under **Drives, Power Supplies, and Other Parts**, click **Return Part**.
 - e. If your screen does not show the Return Part link, contact your service provider for instructions.

Replace a dual inline memory module (DIMM)

Take the following actions to remove the faulted DIMM and install the replacement DIMM into the system.

 **NOTE:** The DIMMs must stay in their original position. Do not move any DIMMs to a different slot.

Identify a faulted DIMM from PowerStore Manager

Before you replace a DIMM, ensure that you have identified its location within the system. Using PowerStore Manager, you can identify and locate a faulted DIMM.

Steps

1. From PowerStore Manager, select **Hardware**.
2. Select the appliance that includes the DIMM that you need to replace.
3. On the **Components** card, under **Internal View**, expand **ExpansionEnclosure**.
4. Select the relevant **DIMM**.

Faulted parts appear in red in the image of the system, and report a status of `Failed` in the **State** field.

5. You can also identify a faulted DIMM by using the following commands:

To display the DIMM information:

```
svc_diag list --expansion_hardware --sub_option dimm
```

To display the status of the NVMe expansion enclosure:

```
svc_diag list --expansion_hardware --sub_option status
```

To display the verbose output of all of the hardware in the NVMe expansion enclosure including health and status.

```
svc_diag list --expansion_hardware
```

NOTE: The `svc_diag list` command takes a few minutes to run.

Remove an Access Module

About this task

NOTE: Access Module 1 is on the top of the NVMe expansion enclosure and Access Module 2 is on the bottom.

Steps

1. Label and remove the cables from the Access Module.
2. Press both orange buttons to release the Access Module latches.

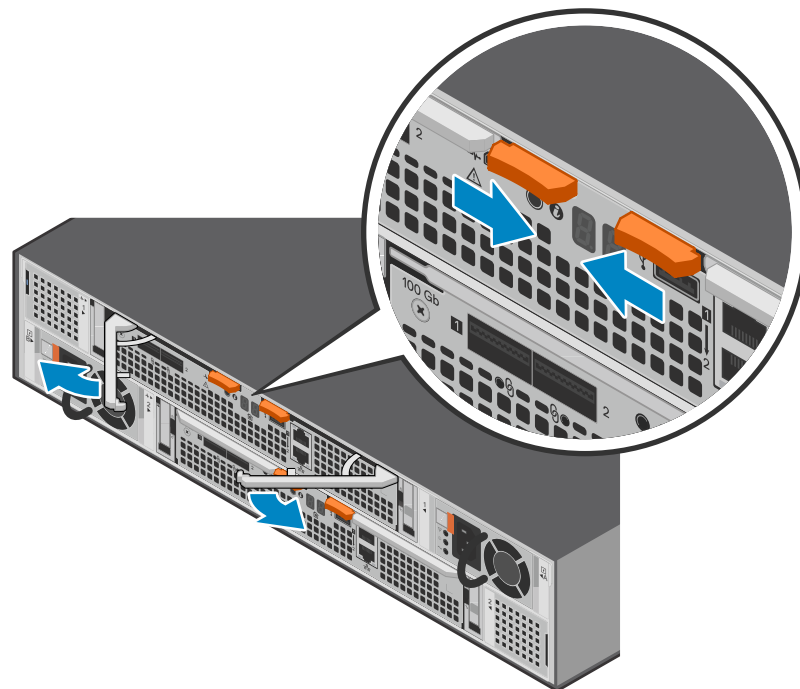

Figure 129. Releasing the Access Module

3. Pull the latches to remove the Access Module from the chassis.

NOTE: The Access Module comes completely out of the chassis. In addition to holding the latches, be prepared to support the Access Module to avoid dropping it.

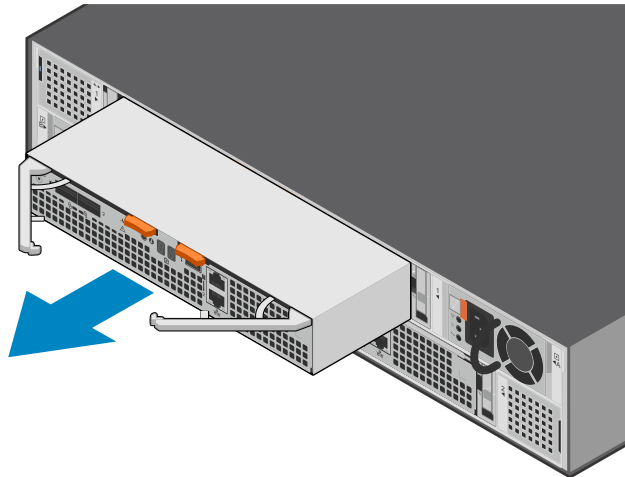

Figure 130. Removing the Access Module

Remove the faulted dual inline memory module

Steps

1. Locate the faulted DIMM in the Access Module by using the figure below as a reference for orientation.

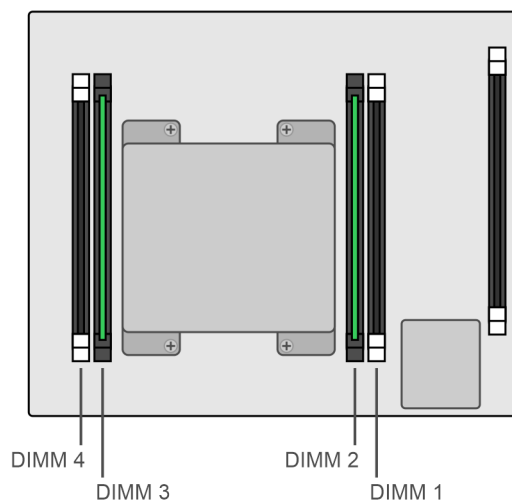

Figure 131. Top view of the Access Module

NOTE: DIMMs are installed in slots 2 and 3.

2. Press the retaining tabs downward to free the DIMM from its slot.
3. Remove the faulted DIMM.

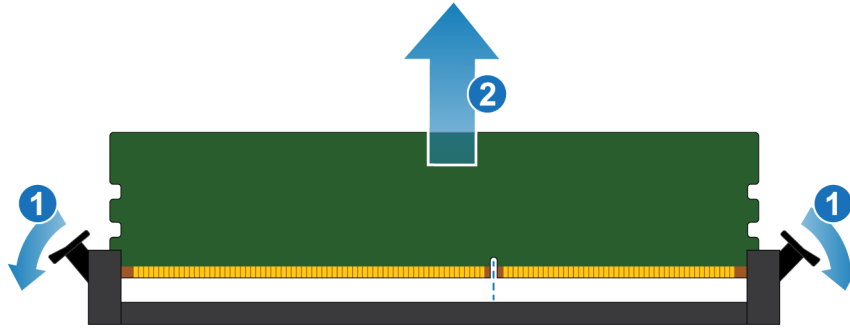

Figure 132. Removing the DIMM

Install the dual inline memory module

Steps

1. Touching only the outside edges of the DIMM, align the DIMM with the connector.
2. Press the DIMM vertically down into the socket using pressure at each end. Keep the leading edge of the DIMM parallel to the connector until it fully seats to the bottom of the socket. When the DIMM engages the contacts in the socket, you will feel resistance, and slightly more force is required to push the module down. During this stage, keep in mind the following precautions:
 - Do not insert the DIMM at an angle.
 - Do not rock the DIMM.
 - Do not insert the DIMM by pushing one end.
 - Do not seat one end of the DIMM and then the other.

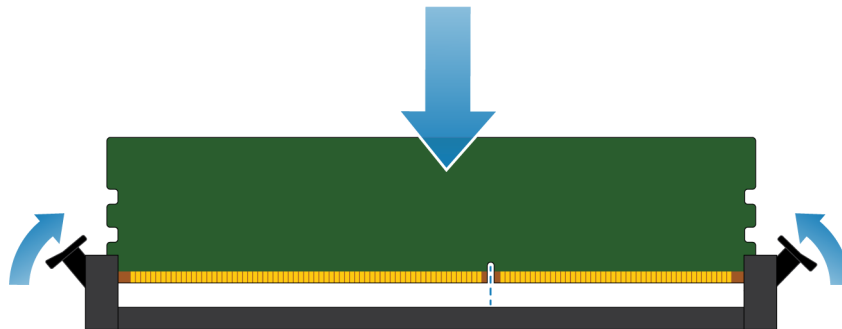

Figure 133. Installing the DIMM

3. Proper DIMM insertion automatically closes the latch ejectors and locks the DIMM into the socket. Verify that the latch ejectors are fully closed and have engaged the notches in the DIMM.

Install an Access Module

Steps

1. Align the Access Module with the empty slot and carefully push it into the slot.

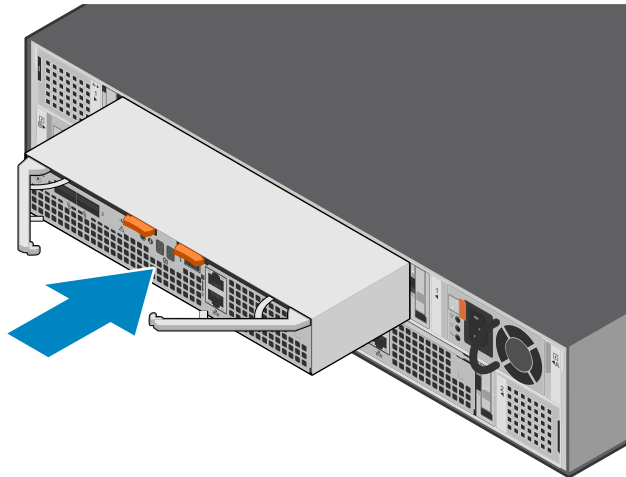

Figure 134. Installing the Access Module

2. Press in on the Access Module latches to lock them into place.

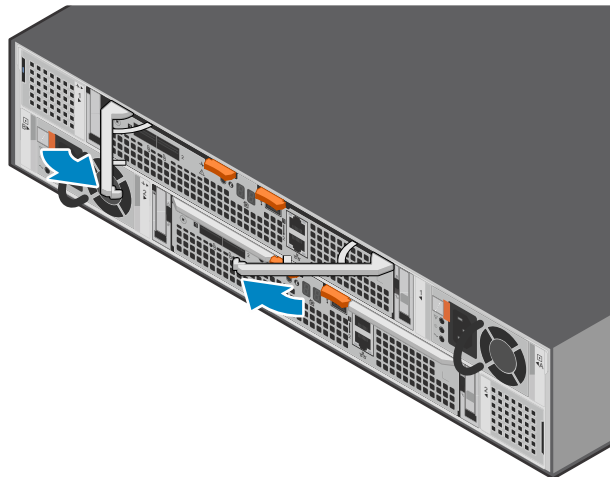

Figure 135. Locking the Access Module into place

3. Connect the cables to the Access Module.

Verify the operation of a replacement DIMM

Steps

1. From PowerStore Manager, select **Hardware**.
2. Select the appliance where you replaced the DIMM.
3. On the **Components** card, under **Internal View**, expand **ExpansionEnclosure**.
4. Select the relevant **DIMM**.

The status of the replacement DIMM should read `Healthy`. If the status is still `Faulted`, wait a few minutes and refresh PowerStore Manager. If the status does not change, ensure that the DIMM is correctly seated, or contact your service provider.

5. You can also verify the operation of a replacement DIMM by using the following commands:

To display the DIMM information:

```
svc_diag list --expansion_hardware --sub_option dimm
```

To display the status of the NVMe expansion enclosure:

```
svc_diag list --expansion_hardware --sub_option status
```

To display the verbose output of all of the hardware in the NVMe expansion enclosure including health and status.

```
svc_diag list --expansion_hardware
```

 **NOTE:** The svc_diag list command takes a few minutes to run.

Return a faulted part

About this task

For US customers, return defective material within five business days. For International customers, return defective material within 10 business days. The materials required to return your defective part are supplied with the good part shipment.

Steps

1. Package the faulted part in the shipping box that contained the replacement part.
2. Ship the failed part to your service provider as described in the instructions that were included with the replacement part.
3. For more information about returning customer-replaceable parts:
 - a. Open PowerStore Manager.
 - b. Click **Settings** on the upper right of the screen.
 - c. Click **General Support**.
 - d. Under **Drives, Power Supplies, and Other Parts**, click **Return Part**.
 - e. If your screen does not show the Return Part link, contact your service provider for instructions.

Safety precautions for handling replaceable units

Review these safety considerations before replacing any parts to avoid damage to your system.

Topics:

- [Handling replaceable units](#)

Handling replaceable units

This section describes the precautions that you must take and the general procedures that you must follow when removing, installing, and storing any replaceable unit.

Avoid electrostatic discharge (ESD) damage

When replacing or installing hardware units, you can inadvertently damage the sensitive electronic circuits in the equipment by simply touching them.

Electrostatic charge that has accumulated on your body discharges through the circuits. If the air in the work area is very dry, run a humidifier in the work area to help decrease the risk of ESD damage.

Follow these procedures to prevent equipment damage:

- Provide enough room to work on the equipment.
- Clear the work site of any unnecessary materials or materials that naturally build up electrostatic charge, such as foam packaging, foam cups, cellophane wrappers, and similar items.
- Do not remove replacement or upgrade units from their antistatic packaging until you are ready to install them.
- Before you begin service, gather the ESD kit and all other materials you need.
- Once servicing begins, avoid moving away from the work site; otherwise, you may build up an electrostatic charge.
- Use ESD anti-static gloves or an ESD wristband (with strap). If using an ESD wristband with a strap:
 - Attach the clip of the ESD wristband to the ESD bracket or bare metal on a cabinet or rack or enclosure.
 - Wrap the ESD wristband around your wrist with the metal button against your skin.
 - If a tester is available, test the wristband.
- If an emergency arises and the ESD kit is not available, follow the procedures in Emergency Procedures (without an ESD kit).

Emergency procedures (without an electrostatic discharge kit)

In an emergency when an electrostatic discharge (ESD) kit is not available, use the following precautions to reduce the possibility of an electrostatic discharge. Ensure that your body and the subassembly are at the same electrostatic potential.

NOTE: These precautions are not a substitute for the use of an ESD kit. Follow them only in an emergency.

- Before touching any unit, touch a bare (unpainted) metal surface of the cabinet, rack, or enclosure.
- Before removing any unit from its anti-static bag, place one hand firmly on a bare metal surface of the cabinet, rack or enclosure, and simultaneously, pick up the unit while it is still sealed in the anti-static bag. Simultaneously, do not move around the room or touch other furnishings, personnel, or surfaces until you have installed the unit.
- When you remove a unit from the anti-static bag, avoid touching any electronic components and circuits on it.
- If you must move around the room or touch other surfaces before installing a unit, first place the unit back in the anti-static bag. When you are ready again to install the unit, repeat these procedures.

Hardware acclimation times

Units must acclimate to the operating environment before applying power. This requires the unpackaged system or component to reside in the operating environment for up to 16 hours in order to thermally stabilize and prevent condensation.

Table 11. Hardware acclimation times

Transit/storage environment		Operating environment temperature	Acclimation time
Temperature	Humidity	-	
Nominal 68-72°F (20-22°C)	Nominal 40-55% RH	Nominal 68-72°F (20-22°C) 40-55% RH	0-1 hour
Cold <68°F (20°C)	Dry <30% RH	<86°F (30°C)	4 hours
Cold <68°F (20°C)	Damp ≥30% RH	<86°F (30°C)	4 hours
Hot >72°F (22°C)	Dry <30% RH	<86°F (30°C)	4 hours
Hot >72°F (22°C)	Humid 30-45% RH	<86°F (30°C)	4 hours
	Humid 45-60% RH	<86°F (30°C)	8 hours
	Humid ≥60% RH	<86°F (30°C)	16 hours
Unknown		<86°F (30°C)	16 hours

- If there are signs of condensation after the recommended acclimation time has passed, allow an additional 8 hours to stabilize.
- Systems and components must not experience changes in temperature and humidity that are likely to cause condensation to form on or in that system or component. Do not exceed the shipping and storage temperature gradient of 45°F/hr (25°C/hr).

Remove, install, or store replaceable units

Use the following precautions when removing, handling, or storing replaceable units:

⚠ WARNING: Some replaceable units have most of their weight in the rear of the component. Ensure that the backend of the replaceable unit is supported while installing or removing it. Dropping a replaceable unit could result in personal injury or damage to the equipment.

⚠ WARNING: A sudden jar drop, or even a moderate vibration can permanently damage some sensitive replaceable units.

i NOTE: For a module that must be installed into a slot in an enclosure, examine the rear connectors on the module for any damage before attempting its installation.

- Do not remove a faulted replaceable unit until you have the replacement available.
- When handling replaceable units, avoid electrostatic discharge (ESD) by wearing ESD anti-static gloves or an ESD wristband with a strap.
- Avoid touching any exposed electronic components and circuits on the replaceable unit.
- Never use excessive force to remove or install a replaceable unit. Take time to read the instructions carefully.
- Store a replaceable unit in the anti-static bag and the specially designed shipping container in which you received it. Use the anti-static bag and special shipping container when you need to return the replaceable unit.

- Replaceable units must acclimate to the operating environment before applying power. This requires the unpackaged component to reside in the operating environment for up to 16 hours in order to thermally stabilize and prevent condensation. Ensure that the replaceable unit has thermally stabilized to the operating environment.
- Front bezels should always be attached to ensure EMI compliance. Ensure that you reattach the bezel after replacing a component.
- Each I/O module or drive slot should contain a component or filler panel to ensure proper air flow throughout the system.

Unpack a part

Use these best practices to unpack a part.

Steps

1. Wear ESD gloves or attach an ESD wristband to your wrist and the enclosure in which you are installing the part.
2. Unpack the part and place it on a static-free surface.
3. If the part is a replacement for a faulted part, save the packing material to return the faulted part.

Power control procedures

Learn how to power down and power up the system.

Topics:

- [Power control procedure considerations](#)
- [Power control procedures preview](#)
- [Powering off procedures for PowerStore node](#)
- [Powering on procedures for PowerStore node](#)
- [Rebooting procedures for a PowerStore node](#)
- [Power off an appliance](#)
- [Power on an appliance](#)
- [Power off a cluster using PowerStore Manager](#)
- [Power on a cluster](#)

Power control procedure considerations

Note the following before you get started:

- Powering off a node, appliance, or cluster can take several minutes to complete.
- In a true emergency power off situation, turn the cabinet power switches to the off position to immediately remove power from the all cabinet components.
- Working with hardware may cause electrostatic discharge that could damage your hardware. Before working with any hardware, take precautions around handling replaceable units. See [Safety precautions for handling replaceable units](#).
- If you are relocating or replacing hardware, to help identify associated enclosures when you are ready to cable and power on:
 - Ensure that you make a note of the cabling between enclosures and the appliances. If you used cable labels at the time of initial installation, reconnecting the cables is easier.
 - Ensure that you also record the Dell Service Tag of each enclosure in your cluster.
- Nodes in the appliance power on into the same mode they were in before the appliance was powered off. If a node powers on in service mode:
 1. Log in to the appliance from an SSH client.
 2. Run the `svc_rescue_state clear` command to clear the boot mode.
 3. Run the `svc_node reboot` command to reboot the node. Once rebooted, the node returns to normal mode. For more information about the service scripts, see the *PowerStore Service Scripts Guide*.
- If both nodes in an appliance reboot in service mode, always return Node A to normal mode first to avoid management software conflicts. After Node A is operating normally, you can return Node B to normal mode.
- Before powering down an appliance with metro volumes, ensure that the role of the metro volumes on the appliance are all set to non-preferred. For information about setting metro volume roles, see the *Protecting Your Data* guide.

Power control procedures preview

CAUTION: Do not power off by pulling cables from the back of the appliance to initiate a shutdown sequence. Use PowerStore Manager or a service script to perform all graceful shutdown operations.

The following table provides a preview of the steps that are required to power off, power on, or reboot the relevant component in your cluster:

Table 12. Power control procedures preview

Component	Action	Procedure
Node	Power off	Use PowerStore Manager or run a service script.

Table 12. Power control procedures preview (continued)

Component	Action	Procedure
	Power on	<ul style="list-style-type: none"> • If the node was removed from the chassis, reseal the node into the chassis, and reconnect its power cable. • If the node was not removed from the chassis, run a service script.
	Reboot	Use PowerStore Manager or run a service script.
Appliance	Power off	Use PowerStore Manager or run a service script.
	Power on	If the nodes or expansion enclosures were removed from the chassis, reseal the expansion enclosures and nodes. Reconnect power cables in the right order.
Cluster	Power off	Use PowerStore Manager or run a service script.
	Power on	If the nodes or expansion enclosures were removed from the chassis, reseal the expansion enclosures and nodes. Reconnect power cables in the right order.

Powering off procedures for PowerStore node

This section includes the following procedures:

- [Power off a node using PowerStore Manager](#)
- [Power off a node using a service script](#)

Power off a node using PowerStore Manager

Prerequisites

Obtain the following information:

- Management IP address of the cluster to log in to PowerStore Manager.
- PowerStore Manager user account credentials with administrator privileges and knowledge of the service account credentials.

NOTE: Do not power off or reboot a node if the peer node is not operating normally. If the peer node is experiencing any major issues, associated alerts and events appear in PowerStore Manager.

Also, to avoid service interruptions, ensure that there are sufficient and healthy paths from all connected hosts to the peer node.

About this task

NOTE: If you are unable to access PowerStore Manager, see [Power off a node using a service script](#).

NOTE: TLC flash drives retain data for up to 90 days while powered off. Data corruption may occur if the drives are powered off for more than 90 days or if they are stored in temperatures above 40° C (104° F).

NOTE: QLC flash drives retain data for up to 30 days while powered off. Data corruption may occur if the drives are powered off for more than 30 days or if they are stored in temperatures above 40° C (104° F).

Steps

1. Under **Hardware**, select the appliance that includes the node you want to power off.
2. On the **Appliance Details** page, select the **Components** card.
3. On the **Components** card, under **Internal View**, select the node that you want to power off.
4. Under **More Actions**, select **Power Down**.
5. On the confirmation prompt, enter the service password, and then click **Power Down**.

Next steps

To verify that the node has powered off, check the status of the LEDs in the rear of the chassis. Other than the LEDs for the power supply unit, management port, and service port, all LEDs on the node must be OFF. The Unsafe to Remove LED on the active or peer node is ON.

Power off a node using a service script

Prerequisites

Obtain the following information:

- Management IP address of the appliance that contains the node. In PowerStore Manager, go to **Settings > Networking > Network IPs > Management**. Review the **Management IPs** table to identify the management IP address associated with the appliance.
- Service account credentials

NOTE: Do not power off or reboot a node, if the peer node is not operating normally. If the peer node is experiencing any major issues, associated alerts and events appear in PowerStore Manager.

Also, to avoid service interruptions, ensure that there are sufficient and healthy paths from all connected hosts to the peer node.

About this task

NOTE: TLC flash drives retain data for up to 90 days while powered off. Data corruption may occur if the drives are powered off for more than 90 days or if they are stored in temperatures above 40° C (104° F).

NOTE: QLC flash drives retain data for up to 30 days while powered off. Data corruption may occur if the drives are powered off for more than 30 days or if they are stored in temperatures above 40° C (104° F).

Steps

1. Launch an SSH client, and connect to the appliance using the management IP address.

NOTE: External SSH management access must be enabled on the appliance.

2. Enter the username and password that is associated with the service account, and log in.

The login prompt indicates the node that you are logged into. For example, the letter "A" in the prompt [SVC:user@DST5467-A~] \$ indicates that you are logged into node A.

3. Based on the node you are logged into, run one of the following commands:
 - `svc_node shutdown local` to power off the node you are logged into.
 - `svc_node shutdown peer` to power off the peer node.

Next steps

To verify that the node has powered off, check the status of the LEDs in the rear of chassis. Other than the LEDs for the power supply unit, management port, and service port, all LEDs on the node must be OFF. The Unsafe to Remove LED on the active or peer node is ON.

Powering on procedures for PowerStore node

This section includes the following procedures:

- [Power on a node using a service script](#)
- [Power on a node by reseating the node](#)

Power on a node using a service script

Prerequisites

Obtain the following information:

- Management IP address of the appliance that contains the node. In PowerStore Manager, go to **Settings > Networking > Network IPs > Management**. Review the **Management IPs** table to identify the management IP address associated with the appliance.
- Service account credentials

About this task

Use the following procedure to power on a node in scenarios such as:

- You are remote and cannot reseal the node.
- The node was not removed from the chassis.
- The embedded module or I/O module were replaced.

Steps

1. Launch an SSH client, and connect to the appliance using the management IP address. Since only the peer node is powered on, you are connected directly to the peer node of the appliance.
2. Enter the username and password that is associated with the service account, and log in.
3. Run the following command:

```
svc_node power_on
```
4. Wait for the node to power on.

 **NOTE:** It may take several minutes for the node to power on.

Power on a node by reseating the node

About this task

Use the following procedure to power on a node after it was removed from the chassis:

Steps

1. Reseat the node into the chassis.
The node powers on automatically.
2. Reconnect the power cable.
3. Wait for the node to complete powering on.

Rebooting procedures for a PowerStore node

This section includes the following procedures:

- [Reboot a node using PowerStore Manager](#)
- [Reboot a node using a service script](#)

Reboot a node using PowerStore Manager

Prerequisites

Obtain the following information:

- Management IP address of the cluster to log in to PowerStore Manager.
- PowerStore Manager user account with administrator privileges.

NOTE: Do not power off or reboot a node if the peer node is not operating normally. If the peer node is experiencing any major issues, associated alerts and events appear in PowerStore Manager.

To avoid service interruptions, ensure that there are sufficient and healthy paths from all connected hosts to the peer node.

About this task

Use the following procedure to reboot a node using PowerStore Manager:

Steps

1. Under **Hardware**, select the appliance that includes the node you want to reboot.
2. On the **Appliance Details** page, select the **Components** card.
3. On the **Components** card, under **Rear View**, expand **Base Enclosure**, and then select the node that you want to reboot.
4. Under **More Actions**, select **Reboot**.
5. On the confirmation prompt, select **Confirm you want to reboot the node**, and then click **Reboot**.

Reboot a node using a service script

Prerequisites

Obtain the following information:

- Management IP address of the appliance that contains the node. In PowerStore Manager, go to **Settings > Networking > Network IPs > Management**. Review the **Management IPs** table to identify the management IP address associated with the appliance.
- Service account credentials

NOTE: Do not power off or reboot a node, if the peer node is not operating normally. If the peer node is experiencing any major issues, associated alerts and events appear in PowerStore Manager.

Also, to avoid service interruptions, ensure that there are sufficient and healthy paths from all connected hosts to the peer node.

About this task

Use the following procedure to reboot a node using a service script:

Steps

1. Launch an SSH client, and connect to the appliance using the management IP address.
2. Enter the username and password for the service account to log in.
The login prompt indicates the node that you are logged into. For example, the letter "A" in the prompt [SVC:user@FNM12345678910-A~]\$ indicates that you are logged into node A.
3. Based on the node you are logged into, run one of the following commands:
 - `svc_node reboot local` to reboot the node you are logged into.
 - `svc_node reboot peer` to reboot the peer node.

For more information, see the *PowerStore Service Scripts Guide*.

Power off an appliance

Prerequisites

- Do not power off the appliance if you are replacing a hardware component. Identify the node that includes the faulted hardware component, and power off only that node. For more information, see [Power off a node using PowerStore Manager](#).
- Powering off an appliance results in the mapped hosts losing access to the data on the appliance. Before you begin, ensure that you temporarily disconnect host access from all storage resources.
- Obtain the following information:

- Management IP address of the appliance. In PowerStore Manager, go to **Settings > Networking > Network IPs > Management**. Review the **Management IPs** table to identify the management IP address associated with the appliance.
- Service account credentials
- Service tags of the appliance

About this task

Use the following procedure to power off a single appliance. To power off all of the appliances in a cluster, see [Power off a cluster using PowerStore Manager](#).

NOTE: TLC flash drives retain data for up to 90 days while powered off. Data corruption may occur if the drives are powered off for more than 90 days or if they are stored in temperatures above 40° C (104° F).

NOTE: QLC flash drives retain data for up to 30 days while powered off. Data corruption may occur if the drives are powered off for more than 30 days or if they are stored in temperatures above 40° C (104° F).

Steps

1. Log in to PowerStore Manager.
2. Determine the primary appliance by going to **Settings > Cluster > Properties**.
3. If the appliance you are shutting down is the primary appliance:
 - a. Launch an SSH client, and connect to the appliance using the management IP address.
 - b. Enter the username and password that is associated with the service account, and log in.
 - c. Run the following command to determine which nodes are eligible to become the new primary node:

```
svc_cluster_management GetClusterStatus
```

- d. Run the following command to specify which appliance you want to become the new primary appliance:

```
svc_cluster_management MovePrimaryAppliance -n <ID number of new primary node>
```

4. In PowerStore Manager, under **Hardware**, select the appliance that you want to power off.
5. Under **More Actions**, select **Power Down**.
The **Validation** window opens.
6. Review any errors, warnings, and recommendations. Once the appliance passes all of the validation checks, click **Next**.
The **Active Objects** window opens.
7. Review the list of objects on the appliance that had I/O activity during the last five minutes.
8. Click **Next**.
The **Confirm** window opens.
9. Enter the service password, and click **Power Down**.
10. Check the status of the LEDs in the rear of chassis to verify that the appliance has powered off. Other than the LEDs for the power supply unit, management port, and service port, all other LEDs on the appliance must be OFF.
11. Wait five minutes, and then disconnect the power cables from the base enclosure.

Power on an appliance

About this task

Use the following procedure to power on an appliance:

Steps

1. If nodes were removed, reseal the nodes into the base enclosure chassis.
2. Reconnect the power cables to node A first, and then node B.
The Node Power LEDs on both nodes turn on when the power cable is connected.

Power off a cluster using PowerStore Manager

Prerequisites

- Powering off a cluster results in the mapped hosts losing access to the data on the cluster. Before you begin, ensure that you temporarily disconnect host access from all storage resources.
- Check if any VMs are using the storage from the cluster. It is recommended to power off the VMs before powering off the cluster.
- When the cluster is powered off, you have no access to the UI, API, or CLI interfaces. Print the power on instructions to ensure that you have the information you require to power on the cluster in a specific order. You can also find these instructions on dell.com/powerstoredocs.
- Obtain the following information:
 - Management IP address of the cluster
 - Service account credentials
 - Site ID
 - Service tags of the appliances

About this task

NOTE: TLC flash drives retain data for up to 90 days while powered off. Data corruption may occur if the drives are powered off for more than 90 days or if they are stored in temperatures above 40° C (104° F).

NOTE: QLC flash drives retain data for up to 30 days while powered off. Data corruption may occur if the drives are powered off for more than 30 days or if they are stored in temperatures above 40° C (104° F).

Steps

1. In PowerStore Manager, select the **Settings** icon, and then select **Power Down** in the **Cluster** section.
2. Click **Power Down Cluster**.
The **Validation** window opens.
3. Click **Perform validation**.
4. Review any errors, warnings, and recommendations. If the cluster passes all the validation checks, click **Next**. If there are remaining errors that can safely be ignored, select **Ignore errors and proceed, regardless of possible data loss**, and then click **Next**.
The **Active Objects** window opens.
5. Review the list of objects on the appliance that had I/O activity during the last five minutes.
6. Click **Next**.
The **Confirm** window opens.
7. Enter the service password, and click **Power Down**.
8. Check the status of the process by looking at the Node Power LEDs. The power off process is complete when the Node Power LEDs for all nodes in the cluster are off.
9. After confirming that the cluster has shut down, disconnect the power cables from both nodes in one of the base enclosures in the cluster, if required. Wait a few seconds and confirm that all remaining LEDs have turned off.
10. If your cluster has more than one appliance, repeat the previous two steps to disconnect power from the remaining appliances in the cluster.

Power on a cluster

About this task

Use the following procedure to power on a cluster:

Steps

1. If nodes were removed, reseal the nodes into the relevant base enclosure chassis.
2. If applicable, for each appliance in the cluster, ensure that expansion enclosures are also reseated into the cabinet.
3. For each appliance, reconnect the power cables to node A first, and then node B.

The Node Power LED on each node turns on when the power cable is connected.

Data collection

Learn how to collect support materials to help troubleshoot the appliances in your system.

Topics:

- [Support materials collection](#)
- [Collect support materials](#)

Support materials collection

You can collect support materials to help troubleshoot the appliances in your system.

Depending on the option you choose, support materials can include system logs, configuration details, and other diagnostic information. Use this information to analyze performance issues, or send it to your service provider so they can diagnose and help you resolve the issues. This process does not collect user data.

You can collect support materials for one or more appliances. When you start a collection, data is always collected at the appliance level. For example, if you request a collection for a volume, the system collects support materials for the appliance that contains the volume. If you request a collection for multiple volumes, the system collects support materials for all appliances that contain the volumes.

You can set a timeframe for collecting support materials. Setting a timeframe can result in smaller and more relevant data collection which is easier to analyze. You can either set a predefined timeframe or set a custom timeframe that suits your needs.

You can also include additional information in the support materials collection from **Advanced collection options**. Collecting additional information can take longer than the default support materials collection, and the size of the resulting data collection is larger. Select this option if your service provider requests it. By default the support materials collection uses the *essentials* profile. Use the `svc_dc` service script to collect support materials for other profiles. See the PowerStore Service Scripts Guide for more information about the `svc_dc` service script and the available profiles.

 **NOTE:** The system can run only one collection job at a time.

You can perform the following actions on a collection of support materials:

- View information about existing collections.
- Upload a collection to support, if remote support through Secure Remote Services is enabled.
- Download a collection to a local client.
- Delete a collection.

 **NOTE:** Some of these operations might not be available if the cluster is operating in a degraded state.

Collect support materials

Steps

1. Select the **Settings** icon, and then select **Gather Support Materials** in the **Support** section.
2. Click **Gather Support Materials**.
3. Type a description of the collection in the **Description** field.
4. Select the timeframe for the data collection.

You can select one of the available options from the **Collection Timeframe** drop-down menu, or select **Custom** and set a timeframe.

 **NOTE:** If you select **Custom** as the timeframe for the data collection, the estimated finish time for the data collection is displayed in the **Collection Timeframe Finish** column of the **Support Materials Library** table.

5. Select the type of support data to collect from the **Object type** drop-down menu.
6. In the **Objects to collect data for:** area, select the check boxes of the appliances from which to collect support data.
7. To send the data collection to support when the job completes, select the **Send materials to Support when finished** check box.
 **NOTE:** This option is available only when Support Connectivity is enabled on the system. You can also send the data collection to support from the **Gather Support Materials** page after the job is completed.
8. Click **Start**.
The data collection is initiated, and the new job appears in the **Support Materials Library** table. You can click the job entry to view its details and progress.

Results

When the job is completed, the job information is updated in the **Support Materials Library** table.

Next steps

After the job is finished, you can download the data collection, send the data collection to support, or delete the data collection.

Maintenance windows

Learn how to enable and disable maintenance windows. During a maintenance window, actions such as unplugging cables and swapping out components will not erroneously alert Customer Support of an outage.

Topics:

- [Enable a maintenance window](#)
- [Disable a maintenance window](#)

Enable a maintenance window

Enable a maintenance window before performing procedures that might erroneously notify Customer Support of problems with the system.

Steps

1. Select the **Settings** icon, and then select **Maintenance Window** in the **Support** section.
2. Select the appliance for which you want to enable a maintenance window and click **Enable/Modify**.
3. In the Maintenance Window Duration field, type the number of days and hours for the maintenance window duration.

 **NOTE:** Specify a time period that is longer than the time it takes to complete the procedure.

4. Click **Apply**.

Results

- The system displays a "Maintenance window was successfully enabled" message that is highlighted in green.
- The Status column shows "Enabled."
- The End Time (Cluster Time) column shows the date and time when the system will re-enable support notifications for the appliance.
- Under **Settings** > **Support**, the system shows "Enabled" next to **Maintenance Window**.

Disable a maintenance window

Disable a maintenance window after completing a procedure that might have erroneously notified Customer Support of problems with the system.

Steps

1. Select the **Settings** icon, and then select **Maintenance Window** in the **Support** section.
2. Select the appliance for which you want to disable the maintenance window and click **Disable**.
3. Click **Apply**.

Results

- The system displays a "Maintenance window was disabled successfully" message that is highlighted in green.
- The Status column shows "Disabled."
- Under **Settings** > **Support**, the system no longer shows "Enabled" next to **Maintenance Window**.

Add appliances to the cluster

Learn how to add appliances to the cluster.

Topics:

- [Add appliances to the cluster](#)

Add appliances to the cluster

Prerequisites

Clusters can include a maximum of four appliances.

Before adding an appliance to the cluster, verify that:

- The management ports for all appliances are connected to the same network.
- The clustering ports are connected to the same cluster network on the native VLAN.
- The cluster is functional and in a healthy state. If any other appliance in the cluster is not operational, you may not be able to add an appliance.
- Ensure that the appliances you are adding are in an unconfigured, original factory setting state.
- You have obtained the Service Tag of the appliance that you want to add.
- You have reserved a minimum of three IP addresses for the management network. One IP address is assigned to each node, and one IP address is assigned to the appliance as a whole. Work with your network administrator to provision and obtain more IP addresses, if necessary. For details, see the *Networking Guide for Storage Services*. To review, or add more IP addresses, select the **Settings** icon, and then select **Network IPs** in the **Networking** section.
- For details about configuring the cluster network on the switch and creating the cluster network in PowerStore Manager, see the *Networking Guide for Storage Services*.
- Review the KB article 000226344 (PowerStore: Supported and Unsupported Cluster Configurations) before adding an appliance to a cluster.

NOTE: The cluster and appliance you are adding must be running the same PowerStoreOS version before the appliance can be added to the cluster. Clusters on PowerStoreOS 3.0.x and later automatically detect if there is a mismatch between operating system versions and provide the option to synchronize during the **Add Appliance** wizard.

For clusters on PowerStoreOS 2.x and earlier where the appliance is running a later version of the PowerStoreOS than the cluster, upgrade the cluster before adding the new appliance.

For clusters on 2.x and earlier where the cluster is running a later version of the PowerStoreOS than the appliance, the appliance should be installed in the same rack and use the same switches as the existing cluster, and configured into its own separate cluster. Then, upgrade the operating system of the separate cluster. See KB article 000133192 (PowerStore Manager prevents "Add an appliance to an existing cluster") for more information.

NOTE: A PowerStore appliance no longer has a System Bond by default. To add an appliance to a PowerStore Cluster, you must create a user-defined bond either before you run the **Add Appliance** wizard or create a bond during the execution of the **Add Appliance** wizard.

NOTE: You can add only one appliance at a time to a PowerStore cluster.

About this task

To add an appliance to the cluster:

Steps

1. Under **Hardware**, click **Add** in the **Appliances** tab.
2. Follow the prompts in the **Add Appliance** wizard to select and add one appliance to your cluster.

NOTE: When this process is running, do not run commands, such as adding external hosts or changing CHAP configurations, which can change the state of the cluster.

NOTE: The PowerStoreOS suspends any operations that you start while the **Add Appliance** process is running until the **Add Appliance** operation is complete.

3. The **Cluster Details** page of the **Add Appliances** wizard displays a list of possible PowerStore appliances that it detects. The **Add Appliances** wizard prompts you to select up to three appliances to the Cluster.
4. If the PowerStoreOS version of the cluster does not match the PowerStoreOS of the appliance being added, you are prompted to synchronize software versions before adding the appliance. Click **Synchronize** to initiate the version synchronization.
When the synchronization is complete, you are returned to the **Add Appliance** wizard. Proceed with the rest of the steps of the wizard.
5. The **Management Network** page of the **Add Appliance** wizard lets you specify three management IP addresses for the appliance that you are adding.
6. The **Clustering Network** page of the **Add Appliance** wizard lets you configure at least two FE ports on each node as members of the clustering bond. If a clustering bond does not yet exist, use the **Create Link Aggregation** button to create a user-defined bond for the cluster. When the clustering bond exists add the FE ports to the clustering bond.
7. Use the **Select Ports for Link Aggregation** button to configure at least two FE ports on each node of the appliance that you are adding as members of the clustering bond.
8. If necessary, upload and install any thin packages that were not installed on the new appliance. See KB article 000226460 (Previously installed thin packages missing following Add Appliance) for more information.

Remove appliances from the cluster

Learn how to remove appliances from the cluster.

Topics:

- [Remove an appliance from a cluster](#)
- [Migrate storage objects from an appliance](#)

Remove an appliance from a cluster

Prerequisites

- Identify the Service Tag of the appliance that you want to remove. For details, see the Hardware Information Guide for PowerStore 1000, 1200, 3000, 3200, 5000, 5200, 7000, 9000, and 9200 or Hardware Information Guide for PowerStore 500T Model .
- If the appliance that you want to remove is not functional, contact your service provider for assistance with removing the appliance.
- Ensure the appliance that you want to remove is not running NAS services.
- Ensure that the appliance is not the only appliance in the cluster.
- Stop and remove all running or scheduled import, migration, or replication jobs on the appliance to remove.
- Before starting the appliance removal process, migrate storage objects from the appliance that you want to remove to another appliance in the cluster. To migrate storage objects, see [Migrate storage objects from an appliance](#).

About this task

A factory reset is performed on an appliance when it is removed from a cluster.

 **NOTE:** When the appliance removal process is running, do not run commands that can change the state of the cluster, such as adding external hosts or changing CHAP configurations.

Steps

1. Disable support notifications on the PowerStore cluster as described in [Enable a maintenance window](#).
2. Under **Hardware**, select **Appliances**, and find the appliance with the Service Tag identified in Prerequisites.
3. If there still are storage objects on the appliance to be removed, use PowerStore Manager to migrate the storage objects to another appliance in the cluster or remove the storage objects from the appliance.
4. Remove the appliance from the cluster in PowerStore Manager.

 **NOTE:** The system resets the appliance to original factory settings and powers it off during the removal process.

- a. Under **Hardware**, select **Appliances**.
- b. Select the checkbox of the appliance to remove.
- c. Click **Remove**.
The **Removing the Appliance** dialog box is displayed.
- d. Click **Remove**.

The appliance is removed from the cluster and reset to its factory default settings. The appliance can be rediscovered and deployed to a new or existing cluster after it is reset to factory default settings.

 **NOTE:** The factory reset of the appliance can take up to 1.5 hours to complete.

Migrate storage objects from an appliance

Use appliance storage object migration to move storage resources to another appliance or multiple appliances in the cluster. This feature is applicable if you want to evacuate space from an appliance, power off an appliance, or remove an appliance from a cluster.

About this task

Volumes, volume groups, and vVols are eligible for migration. When you migrate a storage object, all associated snapshots and thin clones are also migrated.

The following storage objects are not eligible for migration:

Table 13. Storage objects ineligible for migration

Ineligible object	How to make the object eligible
File objects	File objects cannot be migrated.
Volumes or volume groups in an active import session	Wait for the import session to end.
Volumes, volume groups, or vVols in an active internal migration	If the system is migrating objects from the appliance, wait for the migration to end. If the system is migrating objects to the appliance, consider canceling the migration.
Offline volumes	The volume is offline due to metadata inconsistencies. Contact your service provider to bring it online.
vVols with bound snapshots	Interrupt the VMware operation that created the bound snapshot or wait for the process to complete.
vVol bound fast clones	Power off the linked clones of the VM that the vVol belongs to.

You cannot migrate storage objects from an appliance that is out of space and has entered read-only mode. If an appliance is out of space, you must add more storage capacity or delete storage objects until the appliance has at least 16 GB of free space.

To migrate storage objects to another appliance in the cluster:

Steps

1. Under **Hardware**, select the appliance from which you want to migrate storage objects.
2. Under **More Actions**, select **Migrate**.
3. Follow the prompts in the **Migration** wizard to migrate storage objects to another appliance.

 **NOTE:** The maximum number of storage objects that you can select for a single migration action is 4000.

Results

The LUN ID of a volume changes automatically when a volume is migrated from one PowerStore appliance to another appliance in the same cluster.

Follow these guidelines when migrating a boot volume:

- Power off the connected host before migrating the boot volume. Then, change the LUN ID for the boot volume after the migration is performed and power on the host.
- The recommend Host LUN ID for a boot LUN is 0.
- After migrating a boot from SAN volume, the LUN ID can be changed back to 0.

 **NOTE:** For instructions on changing the LUN, see the PowerStore Host Configuration Guide.

Reinitialize the system

Learn how to reset the entire system to the original, default factory settings.

Topics:

- [Reinitialize the system](#)

Reinitialize the system

Reinitializing the system resets the entire system to the original, default factory settings. You can reinitialize the system using service scripts. To use service scripts to reinitialize the system, see the *PowerStore Series Service Scripts Guide*.

 **CAUTION:** Reinitializing the system will result in data loss.

 **NOTE:** Do not disconnect, remove, replace, or swap system parts before or during system reinitializing. Any such changes will cause the reinitialization to fail.