

Dell PowerStore

Hardware Information Guide for PowerStore 500T Model

Version 4.x

Notes, cautions, and warnings

 **NOTE:** A NOTE indicates important information that helps you make better use of your product.

 **CAUTION:** A CAUTION indicates either potential damage to hardware or loss of data and tells you how to avoid the problem.

 **WARNING:** A WARNING indicates a potential for property damage, personal injury, or death.

Additional Resources	4
Chapter 1: Platform overview	5
Description.....	5
Chapter 2: Base enclosure component descriptions	6
Base enclosure component overview.....	6
Base enclosure front view.....	7
System identification tags.....	8
Base enclosure rear view.....	9
Base enclosure embedded modules and 4-port cards.....	10
Base enclosure I/O module types.....	12
Base enclosure AC power supply.....	13
Base enclosure DC power supply.....	14
Node internal components.....	14
Chapter 3: 24 Drive 2.5 Inch NVMe expansion enclosure (ENS24) component descriptions	16
NVMe expansion enclosure.....	16
NVMe expansion enclosure front view.....	16
NVMe expansion enclosure rear view.....	17
NVMe expansion enclosure internal components.....	20
Chapter 4: Technical specifications	23
Dimensions and weight for the PowerStore 500T	23
Dimensions and weight for the NVMe expansion enclosure.....	23
Power requirements for PowerStore 500T.....	24
High ambient temperature shutdown for PowerStore 500T.....	25
Power requirements for the NVMe expansion enclosure.....	25
Considerations for TLC and QLC drives.....	26
Operating environment limits.....	26
Shipping and storage requirements.....	26
Base enclosure airflow.....	26
Environmental recovery.....	27
Air quality requirements.....	27
Fire suppressant disclaimer.....	27
Shock and vibration.....	28

As part of an improvement effort, revisions of the software and hardware are periodically released. Some functions that are described in this document are not supported by all versions of the software or hardware currently in use. The product release notes provide the most up-to-date information about product features. Contact your service provider if a product does not function properly or does not function as described in this document.

Where to get help

Support, product, and licensing information can be obtained as follows:

- **Product information**—For product and feature documentation or release notes, go to the [PowerStore Info Hub](#).
- **Troubleshooting**—For information about products, software updates, licensing, and service go to [Dell Support](#) and locate the appropriate product support page.
- **Technical support**—For technical support and service requests, go to [Dell Support](#) and locate the **Service Requests** page. To open a service request, you must have a valid support agreement. Contact your Sales Representative for details about obtaining a valid support agreement or to answer any questions about your account.

Customer feedback

A feedback button is located at the right side of the PowerStore Manager. Selecting **Feedback** opens a browser window where you can fill and submit a feedback survey.

Platform overview

Topics:

- [Description](#)

Description

PowerStore 500T appliances serve Block and File services, and the software stack is deployed directly on the system.

The PowerStore 500T hardware consists of a 2U, two node storage solution. The enclosure as a whole is called a base enclosure.

Between the front and rear of the enclosure, a mid-plane distributes power and signals to all the enclosure components. On the front of the base enclosure, drives connect to the mid-plane. On the rear of the base enclosure, the nodes and power supply modules connect to the mid-plane. The I/O modules connect directly to the node. Each node contains an internal battery backup module, redundant fan modules, DDR4 memory, and one Intel Cascade Lake 12C processor.

Base enclosure component descriptions

Topics:

- [Base enclosure component overview](#)
- [Base enclosure front view](#)
- [Base enclosure rear view](#)
- [Node internal components](#)

Base enclosure component overview

The 2U, 25-drive base enclosure consists of the following components:

- Slots for 25 2.5-inch NVMe drives
- Midplane
- Two nodes
- Power supply module (AC or DC)
- EMI shielding

Drives

Each drive resides in a drive carrier. The drive carriers are metal and plastic assemblies that provide smooth, reliable contact with the enclosure slot guides and mid-plane connectors. Each carrier has a handle with a latch and spring clips. The latch holds the drive in place to ensure proper connection with the mid-plane. Drive activity and fault LEDs are on the front of the enclosure.

There are two supported drive types:

- NVMe SSD
 - The NVMe SSD drives in the PowerStore 3200Q are QLC-based.
 - The NVMe SSD drives in all other PowerStore models are TLC-based.
- NVMe SCM

You can mix NVMe SSD and NVMe SCM drives in the same base enclosure. If you mix drive types, the system uses the NVMe SCM drives for metadata tiering.

NOTE: A minimum of six NVMe SSD or NVMe SCM drives must be installed in the base enclosure. If the minimum number of drives is not populated, the base enclosure will not initialize.

Midplane

The mid-plane separates the front-facing drives from the rear-facing nodes. It distributes power and signals to all components in the enclosure. The nodes and drives plug directly into the mid-plane.

Nodes

Each base enclosure contains two nodes. The node is the intelligent component providing the compute capability of the base enclosure.

Node power supply module

Each node contains a power supply module that connects the system to an exterior power source. The system supports either AC power or DC power. If one power supply fails, the redundant power supply can keep the entire base enclosure running. The power supplies include LEDs to indicate component status. A latch on the module locks it into place to ensure proper connection.

EMI shielding

EMI compliance requires a properly installed electromagnetic interference (EMI) shield in front of the base enclosure drives. When installed in cabinets that include a front door, the base enclosure includes a simple EMI shield. Other installations require a front bezel that has a locking latch and integrated EMI shield. Remove the bezel or shield to remove and install the drives.

Base enclosure front view

The front of the base enclosure contains the following elements:

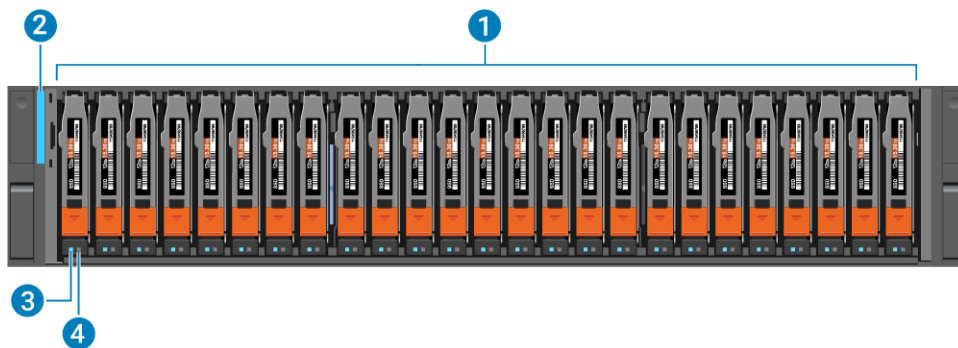

Figure 1. Base enclosure front view

Table 1. Base enclosure component locations

Location	Description
1	SSD or SCM NVMe drives
2	Base enclosure power on LED
3	Drive power and activity LED
4	Drive fault LED



Figure 2. Base enclosure and drive LEDs

Table 2. Base enclosure and drive LEDs

LED	Location	State	Description
Drive fault	1	Amber	Fault has occurred.
		Off	No fault has occurred.
Drive activity	2	Blue	Drive activity.
		Off	The drive is powered off.
Base enclosure power and fault	3	Blue	Power is on. No fault has occurred.
		Amber*	Power is on. Fault has occurred within the enclosure.
		Blue and amber alternating	System not initialized.
		Off	The power is off.

* Failure of the following components results in the amber fault state:

- Fan module
- Power supply
- DIMM
- Internal battery backup module
- Node
- Embedded module
- 4-port card
- I/O module
- Internal M.2 boot module

System identification tags

The Service Tag and World Wide Name Seed are serialized labels for tracking hardware components.

Service Tag

The Service Tag for the 25-slot base enclosure is a black pull-out tag that is located between the drives in slots 16 and 17. The Service Tag includes the following information:

- Quick Resource Locator (QRL)
- Array Model Name
- Dell Service Tag Number (ST) with seven alphanumeric characters
- Express Service Number (EX)

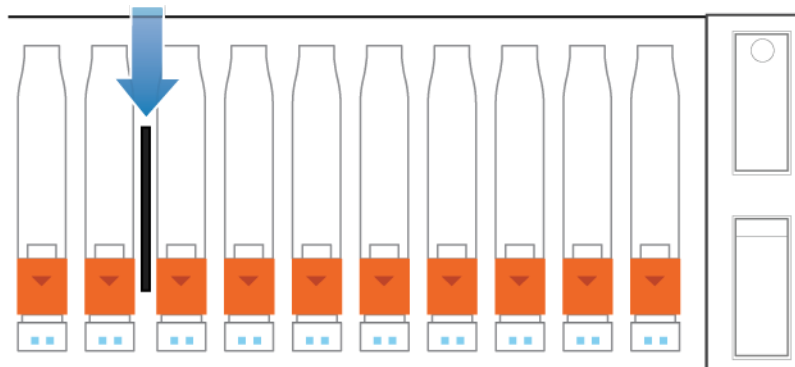

Figure 3. Service Tag location

World Wide Name Seed Tag

The World Wide Name (WWN) Seed Tag is a blue pull-out tag that is located between the drives in slots 7 and 8. The WWN Seed Tag includes the following information:

- Serial Number (SN) that matches the Dell Service Tag Number on the black Service Tag
- Part Number (PN)
- Serial Number (SN) with 14 alphanumeric characters
- WWN Seed

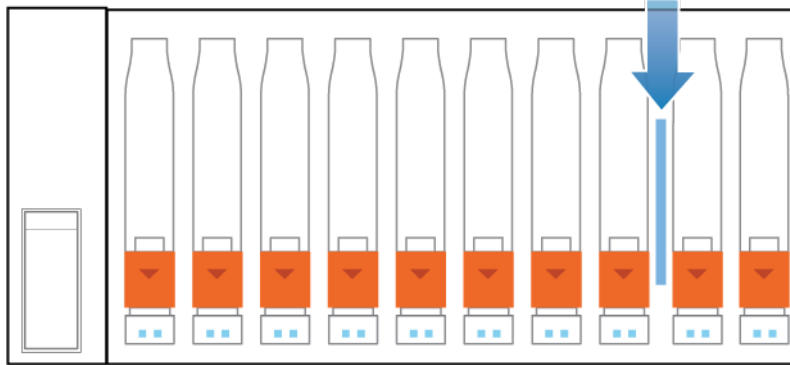

Figure 4. WWN Seed Tag location

Base enclosure rear view

The rear of the base enclosure contains two nodes: node A and node B.

Each node contains the following hardware components:

- One embedded module
- Two optional I/O modules
- One power supply module with either AC power or DC power

NOTE: The figure below shows the AC power supply.

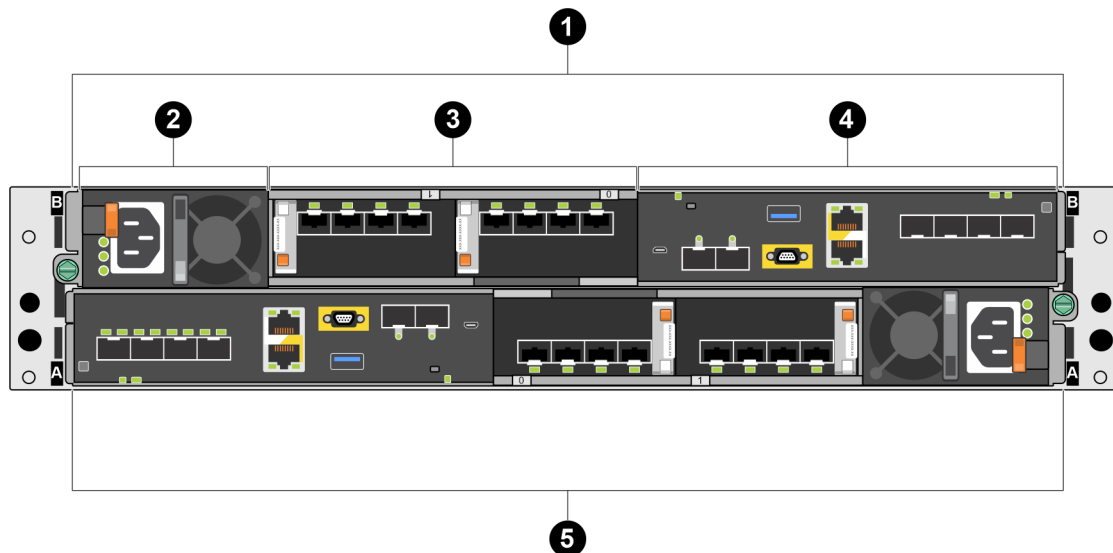

Figure 5. Base enclosure rear view with hardware component locations

Table 3. Base enclosure hardware component locations

Location	Description
1	Node B
2	Power supply module
3	I/O module slots 0 and 1
4	Embedded module
5	Node A

Base enclosure embedded modules and 4-port cards

About embedded modules

Each node contains one embedded module that can hold one 4-port card for front-end connectivity and internal communication between nodes and appliances. The first two ports of the 4-port card on the embedded module connect to a Top-of-Rack (ToR) switch. The second two ports are reserved for backend connectivity to an NVMe expansion enclosure.

The 4-port card is optional if the base enclosure is configured for block-optimized storage and is not part of a cluster.

NOTE: Both nodes must have the same type of embedded modules in the same slots.

The embedded module contains the following components:

- One 4-port card (optional)
- Two fixed 10GbE optical ports
- Two RJ45 LAN connectors
 - System management port (🔌)
 - Service port (🔌)
- One USB port
- One non-maskable interrupt (NMI) button
- One mini-serial port (unused)
- One micro DB9 serial port (service)

NOTE: The following figure shows the location of these components on the embedded module in node A. The locations of the components in node B are mirrored.

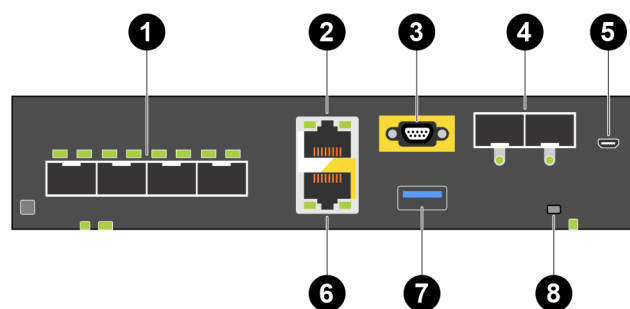

Figure 6. Embedded module rear view with component locations

Table 4. Embedded module component locations

Location	Description
1	4-port card
2	RJ 45 LAN connector - system management port
3	Micro DB9 serial port (service)
4	Fixed 10GbE optical ports

Table 4. Embedded module component locations (continued)

Location	Description
5	Mini serial port (unused)
6	RJ45 LAN connector - service port
7	USB port
8	Non-maskable interrupt (NMI) button

About the 4-port card

The 4-port card is an optional 25GbE SFP-based component that is located within the embedded module. The 4-port card is required for connecting to NVMe expansion enclosures.

The 4-port 25GbE SFP based embedded module supports 10GbE or 25GbE SFP28, 25GbE passive TwinAx, and 10GbE active or passive TwinAx. The ports may be configured individually with TwinAx or any of the supported SFPs.

NOTE: 25GbE SFPs only support 25GbE speeds.

Embedded module and 4-port card LED status

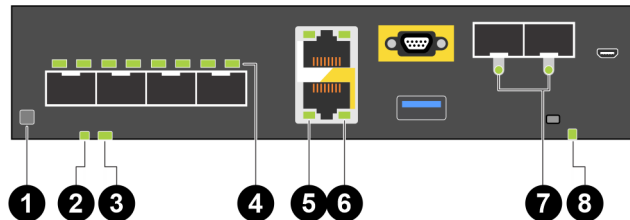

Figure 7. Embedded module LEDs

Table 5. Embedded module LEDs

LED	Location	State	Description
Unsafe to remove	1	White	Do not remove the node. Improper removal could cause data loss.
		Off	Safe to remove the embedded module when the embedded module has been properly prepared.
Node power	2	Green	Node is on (main power).
		Green blinking	Node is initializing a serial over LAN session.
		Off	Node is off.
Node fault	3	Amber	Fault has occurred.
		Blue	Node in Degraded Mode.
		Amber or blue blinking	The system is booting.
		Blue and amber alternating (green for 3 seconds)	System not initialized. A management IP address has not been assigned.
		Blue and amber alternating at one second intervals.	Node in Service Mode.

Table 5. Embedded module LEDs (continued)

LED	Location	State	Description
		Off	No fault has occurred, normal operation.
4-port card port link	4	Green	Link up with high speed.
		Amber	Link up with degraded speed.
		Off	Link down.
Ethernet port activity	5	Amber blinking	Port activity.
		Off	No port activity.
Ethernet port link	6	Green	Link established.
		Off	No link was established.
2-port card port link	7	Green	Link up with high speed.
		Amber	Link up with degraded speed.
		Off	Link down.
Embedded module fault	8	Amber	Embedded module has faulted.
		Off	No fault has occurred, normal operation.

Base enclosure I/O module types

4-port 25GbE SFP based I/O module

The 4-port 25GbE SFP based I/O module is an Ethernet I/O module that is used to serve Ethernet network traffic and iSCSI block protocol to hosts for the platform. The I/O module supports 10GbE SFP, 10GbE active and passive TwinAx, 25GbE SFP28, and 25GbE passive TwinAx.

4-port BaseT I/O module

The 4-port BaseT I/O module can interface at speeds of 1 Gb/s and 10 Gb/s and supports both Ethernet network traffic and iSCSI (Block) on the same node. Ports can be configured as both IP and iSCSI simultaneously. The I/O module comes with four 10-Gb/s RJ-45 ports, one power/fault LED, activity LED, and link LED for each port.

4-port 32Gb Fibre Channel I/O module

The 4-port 32Gb Fibre Channel I/O module is used to serve Fibre Channel block protocol via SAN to hosts for the platform. The I/O module is available with either 16G FC SFP modules or with 32G FC SFP modules. Each port has an optical 16G/32G capable SFP connection to a host or switch port.

I/O module LED status

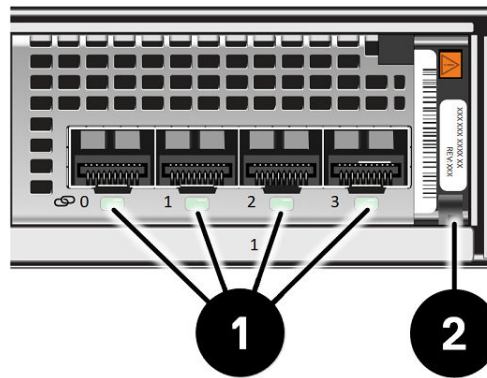

Figure 8. Base enclosure 4-port I/O module LEDs

Table 6. Base enclosure 4-port I/O module LEDs

LED	Location	State	Description
Port link	1	Green or blue	Link up
		Off	Link down
Power fault	2	Green	Power on
		Amber	Power fault

Base enclosure AC power supply

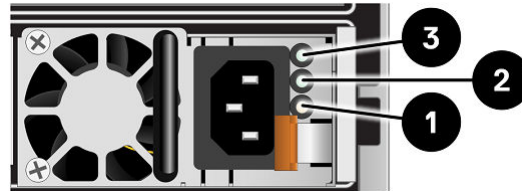

Figure 9. Base enclosure AC power supply LEDs

Table 7. Base enclosure AC power supply LEDs

LED	Location	State	Description
Fault	1	Solid amber	Power supply or backup fault. Check the cable connection.
		Off	No fault.
Supply output status	2	Green	Outputs are normal.
		Off	Outputs are faulted or disabled.
AC power (input)	3	Green	AC power is on.
		Off	AC power is off. Verify the source power.

Base enclosure DC power supply

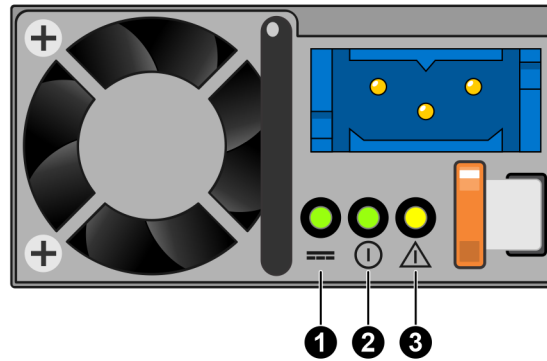

Figure 10. Base enclosure DC power supply LEDs

Table 8. Base enclosure DC power supply LEDs

LED	Location	State	Description
DC power (input)	1	Green	DC power is on.
		Off	DC power is off. Verify the source power.
DC power (output)	2	Green	The power supply is operating normally.
		Off	The power supply is not operating properly.
Fault	3	Amber	Power supply fault. Check the cable connection.
		Amber blinking	Over temperature fault.
		Off	No fault.

Node internal components

Included within the node are the following components:

- Dual inline memory modules (DIMMs)
- Internal battery backup module
- Internal M.2 boot module
- Fan modules

Dual inline memory modules

Six 288-pin DIMM sockets with six 16 GB DDR4 DIMMs for 96 GB of DDR4 memory.

Internal battery backup module

Provides power to the CPU and enables cache vaulting during power loss or node panic. Encrypts and backs up cache data to the internal M.2 boot module.

Internal M.2 boot module

Each node has one 240 GB internal M.2 boot module.

Fan modules

Six redundant fan modules connect to the motherboard within the node. These fan modules provide continuous airflow through the front drives and through the rear of the node to keep the components at optimal operating temperatures. Each fan module contains two fan rotors.

 **NOTE:** If two fan rotors fail within the same node, the system performs a protective thermal shutdown of the node.

24 Drive 2.5 Inch NVMe expansion enclosure (ENS24) component descriptions

Topics:

- [NVMe expansion enclosure](#)

NVMe expansion enclosure

The NVMe expansion enclosure includes slots for 24 2.5-inch NVMe SSD drives. It uses an NVMe interface for communication between the nodes and the NVMe expansion enclosure. The NVMe expansion enclosure uses the RDMA over Converged Ethernet (RoCE) network protocol to enable Remote Direct Memory Access (RDMA). This allows the system to encapsulate RDMA packets over Ethernet, which results in low latency, lower CPU usage, and higher bandwidth. Because PowerStore utilizes an NVMe over Fabric (NVMe/OF) standard, the NVMe expansion enclosure delivers an end-to-end NVMe solution.

NOTE: The NVMe expansion enclosure requires that the base enclosure includes a 25 GbE 4-port card.

NOTE: The NVMe expansion enclosure does not support NVMe SCM drives and is not supported with SCM-only base enclosures.

NVMe expansion enclosure front view

The NVMe expansion enclosure front view includes the following components:

- PCIe NVMe SSD drives in 2.5-inch carriers (hot-swappable)
- Status LEDs

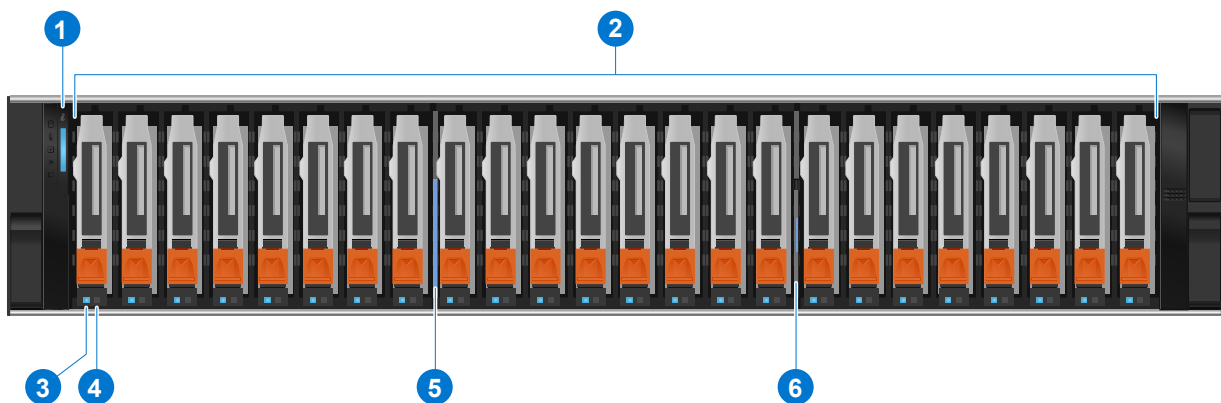

Figure 11. NVMe expansion enclosure front view front view

Table 9. NVMe expansion enclosure front view component locations

Location	Description
1	Expansion enclosure status LEDs
2	2.5-inch NVMe drives
3	Drive status and activity (blue)

Table 9. NVMe expansion enclosure front view component locations (continued)

Location	Description
4	Drive fault LED (amber)
5	World Wide Name (WWN) Seed Tag
6	Service Tag

Table 10. Drive status LEDs

LED	Location	Color	State	Description
Drive power and activity	3	Blue	On	Powering up and powered up
			Blinking	Drive activity
Drive fault	4	Amber	On	Fault
		—	Off	No fault

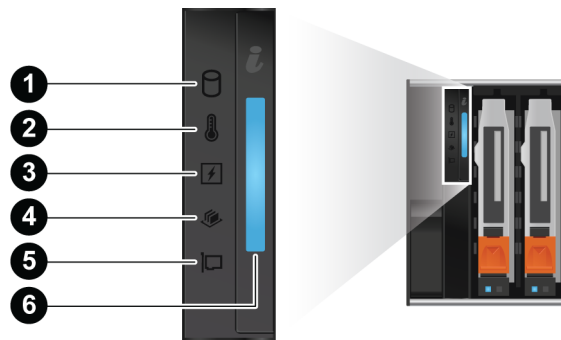

Figure 12. NVMe expansion enclosure front view status LEDs

Table 11. NVMe expansion enclosure front view status LEDs

LED	Location	Color	State	Description
Drive Status	1	Amber	On	Drive fault, unsupported drive, or rebuilding
		Green	On	No fault
Temperature Status	2	Amber	On	Overheating component
		Green	On	No fault
Electrical Status	3	Amber	On	PSU failure or incorrect voltage range
		Green	On	No fault
Memory Status	4	Amber	On	DIMM failure
		Green	On	No fault
Drive Interface Status	5	Amber	On	Clockboard or Ethernet interface failure
		Green	On	No fault
Indication LED	6	—	Off	Powered on and healthy
		Blue	Blinking	System ID mode enabled
		Amber	Blinking	Hardware fault

NVMe expansion enclosure rear view

The rear of the NVMe expansion enclosure includes the following components:

- Two Link Controller Cards (LCCs) that contain the following components:
 - Access Module
 - Drive Interface Board located behind the Access Module
- Two power supply modules

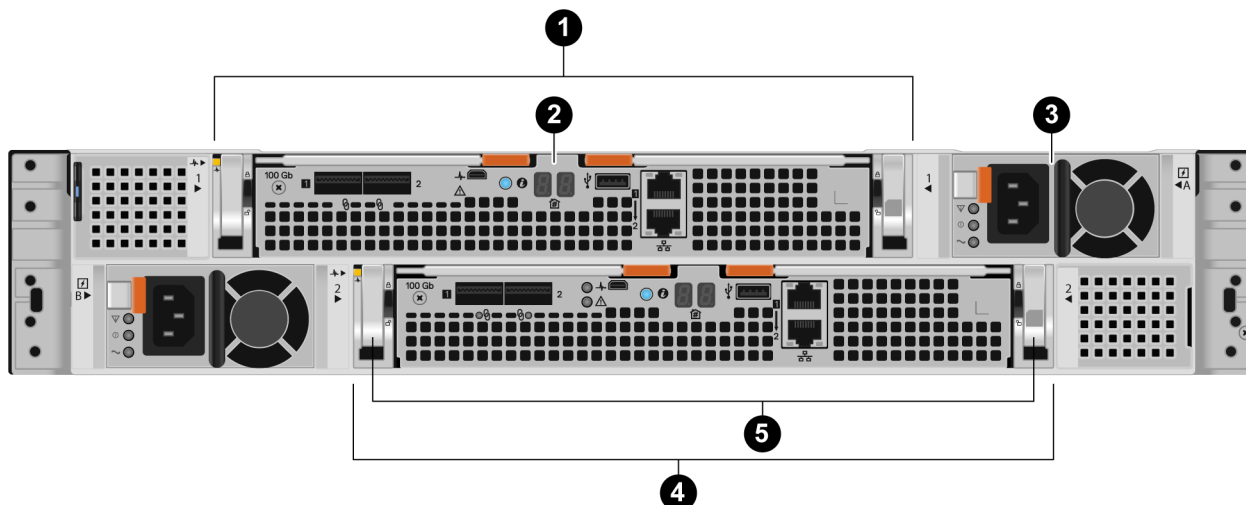

Figure 13. NVMe expansion enclosure rear component locations

Table 12. NVMe expansion enclosure hardware component locations

Location	Description
1	LCC 1
2	Access Module
3	Power supply module
4	LCC 2
5	Drive Interface Board

NVMe expansion enclosure LCC

About LCCs

Each NVMe expansion enclosure contains two LCCs, and each LCC contains an Access Module and a Drive Interface Board that is located behind the Access Module. The Drive Interface Board connects the front-end to the back-end and contains the PCIe switches that connect the drives and the Access Module.

The Access Module manages and reports the environmental conditions of the NVMe expansion enclosure such as power, thermal, status indicators, and component presence. The Access Module employs NVMe-oF (NVMe over Fabrics) technology by using RDMA over Converged Ethernet (RoCE) for Ethernet. This technology allows the Access Module to perform the translation of the persistent storage data received over the Ethernet interfaces and transfer it onto the PCIe connections of the NVMe drives. The Access Module also applies the data protection that is deployed by the system.

The Access Module contains the following components:

- Two 100GbE ports (QSFP28) for connecting the NVMe expansion enclosure to the base enclosure and for daisy chaining additional NVMe expansion enclosures.
- One micro USB port (not used)
- One USB port (not used)
- Two 1GbE RJ45 management ports (for support only)

The following figure shows the location of these components:

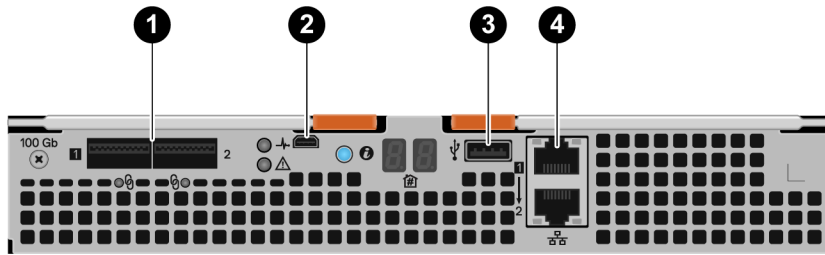

Figure 14. Access Module rear view with component locations

Table 13. Access Module component locations

Location	Description
1	100GbE ports (QSFP28)
2	Micro USB port (not used)
3	USB port (not used)
4	1GbE RJ45 management ports (for support only)

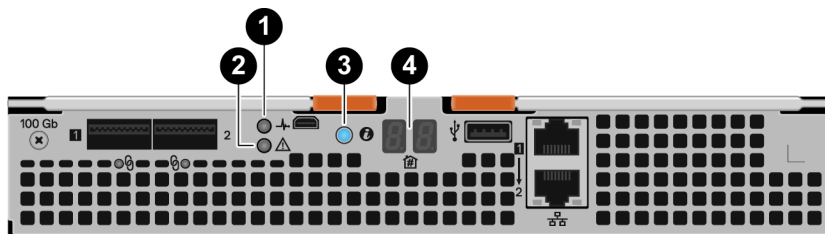

Figure 15. Access Module LEDs

Table 14. Access Module LEDs

LED	Location	State	Description
Power status	1	Green	Power on.
		Off	Power off.
Fault status	2	Amber	Faulted hardware.
		Off	No fault has occurred. Normal operation.
System ID	3	Blinking blue	System ID mode is enabled.
		Off	System ID mode is not enabled.
Daisy chain ID	4	50–52	Identifies where in the daisy chain the expansion enclosure is located: <ul style="list-style-type: none"> 50 - First expansion enclosure 51 - Second expansion enclosure 52 - Third expansion enclosure

NVMe expansion enclosure AC power supply

The NVMe expansion enclosure includes two 1800W AC power supplies.

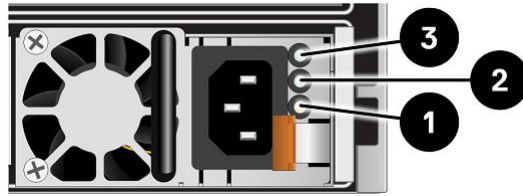

Figure 16. NVMe expansion enclosure AC power supply LEDs

Table 15. NVMe expansion enclosure AC power supply LEDs

LED	Location	State	Description
Fault	1	Solid amber	Power supply or backup fault. Check the cable connection.
		Off	No fault.
DC power (output) - Not supported	2	Green	N/A
		Off	N/A
AC power (input)	3	Green	AC power is on.
		Off	AC power is off. Verify the source power.

NVMe expansion enclosure internal components

Included within the NVMe expansion enclosure are the following components:

Fan modules

Six redundant fan modules provide continuous airflow through the front drives and through the rear of the expansion enclosure to keep the components at optimal operating temperatures. Each fan module contains two fan rotors.

NOTE: If three fan rotors fail in an expansion enclosure, the system performs a protective thermal shutdown of the expansion enclosure.

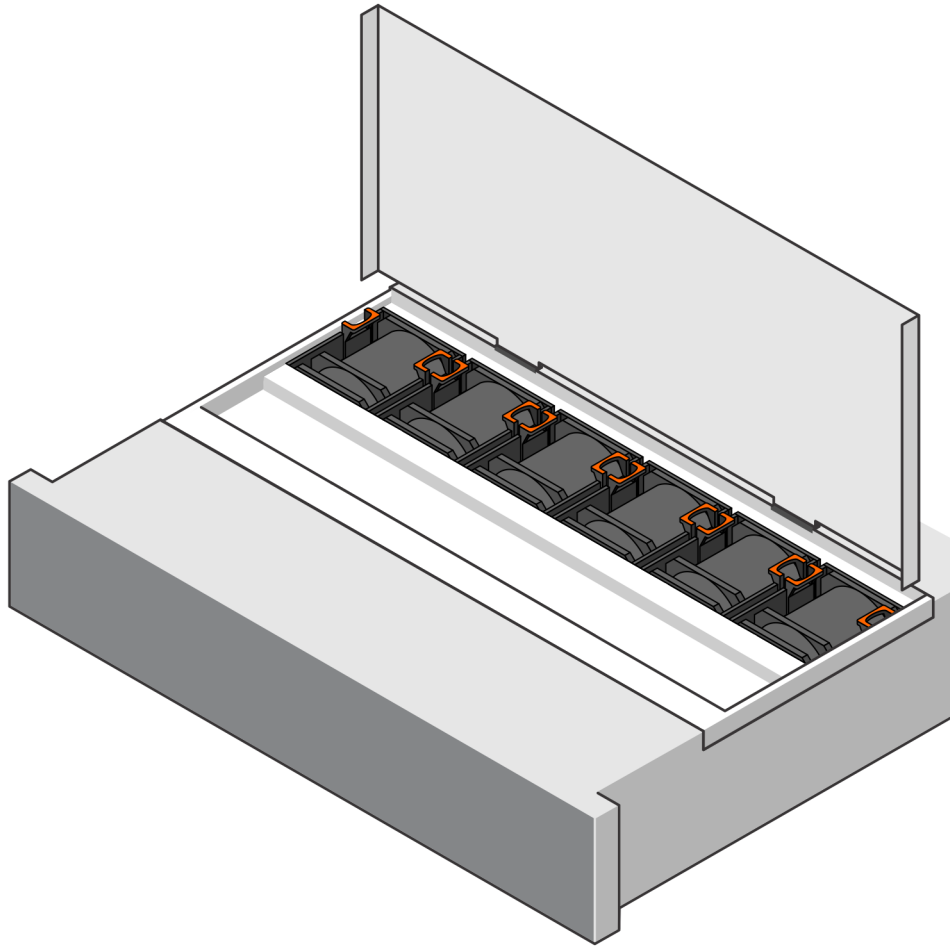

Figure 17. NVMe expansion enclosure fan modules

Clock Distribution Boards

Two Clock Distribution Boards provide a common clock to the drives.

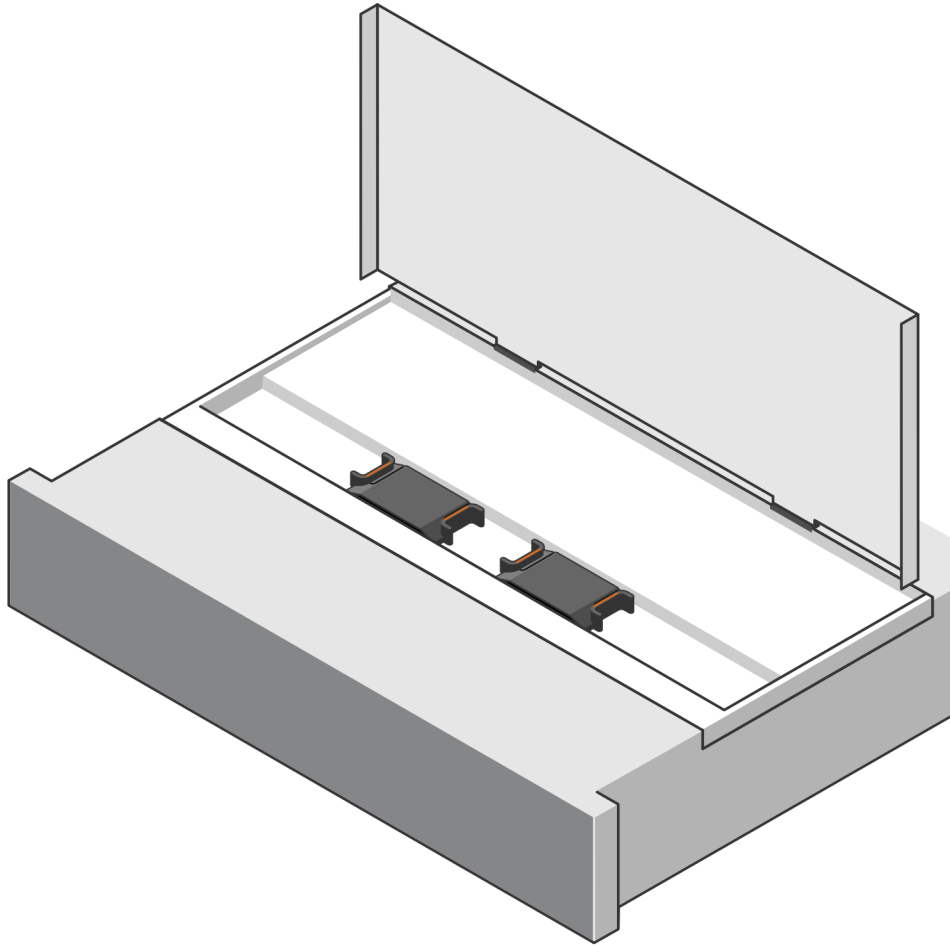

Figure 18. NVMe expansion enclosure Clock Distribution Boards

Dual inline memory modules (DIMMs)

Two 8 GB DDR4 DIMMs provide 16 GB of memory. The DIMMs are located inside the Access Module in slots 2 and 3.

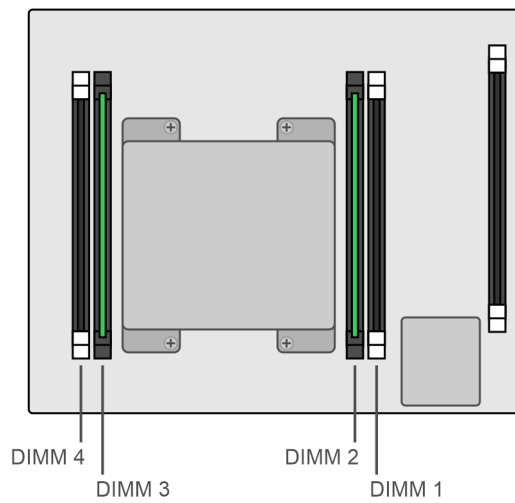

Figure 19. NVMe expansion enclosure DIMMs

Technical specifications

Topics:

- Dimensions and weight for the PowerStore 500T
- Dimensions and weight for the NVMe expansion enclosure
- Power requirements for PowerStore 500T
- High ambient temperature shutdown for PowerStore 500T
- Power requirements for the NVMe expansion enclosure
- Considerations for TLC and QLC drives
- Operating environment limits
- Shipping and storage requirements

Dimensions and weight for the PowerStore 500T

Table 16. Base enclosure dimensions and weight

Dimension	Value
Weight (fully populated)	37.4 kg (82.4 lbs)
Vertical size	Two NEMA units
Height	8.64 cm (3.4 in)
Width	44.45 cm (17.5 in)
Depth	79.5 cm (31.3 in)

NOTE: The weight does not include mounting rails. Allow 3.6 kg (8 lbs) for a rail set.

NOTE: The adjustable mounting rails span 558 mm to 914 mm (22 in to 36 in).

Dimensions and weight for the NVMe expansion enclosure

Table 17. NVMe expansion enclosure dimensions and weight

Dimension	Value
Weight (fully populated)	26.08 kg (57.5 lb) (not including cable management arms or mounting rails)
Vertical size	Two NEMA units
Height	8.89 cm (3.5 in)
Width	43.18 cm (17 in)
Depth	65.30 cm (25.71 in)
Depth with cable management arms	84.86 cm (33.41 in)

Power requirements for PowerStore 500T

Power requirements vary depending on system configuration, loading, and environmental conditions. The table below provides worst case data. To estimate power consumption values for your specific environment, use the [Dell Power Calculator](#).

Table 18. Power requirements for AC power

Requirement	PowerStore 500T
Maximum input power	100 to 240 VAC ± 10%, single phase
AC line current (operating maximum)	10 A max at 100 VAC
	5 A max at 200 VAC
Power consumption (operating maximum at 200 VAC)	1004.1 VA (984 W)
Heat dissipation (operating maximum at 200 VAC)	3.54 x 10 ⁶ J/hr (3,358 Btu/hr)
AC inlet type (high line)	IEC320-C14 appliance coupler per power zone (200 VAC)
AC inlet type (low line)	IEC320-C20 appliance coupler per power zone (100 VAC)
Normal input frequency	47 Hz–63 Hz
Maximum inrush current	45 Apk "cold" per line cord at any line voltage
AC protection	20 A fuse on each power supply, single line
Ride-through time	10 ms min
Current sharing	± 5 percent of full load between power supplies
Startup surge current	120 Apk "hot" per line cord, at any line voltage

Table 19. Power requirements for DC power

Requirement	PowerStore 500T
DC line voltage	-39 to -72 DC
DC line current (operating maximum)	28.2 max at -39 VDC
	22.9 max at -48 VDC
	15.3 max at -72 VDC
Power consumption (operating maximum)	1100 W
Heat dissipation (operating maximum at 200 VAC)	3.96 x 10 ⁶ J/hr (3,753 Btu/hr)
DC inlet type	Positronics PLBH3W3M4B0A1/AA
Maximum inrush current	40 A peak
DC protection	50 A fuse in each power supply
Ride-through time	1 ms min at -50 V input
Current sharing	± 5 percent of full load between power supplies

High ambient temperature shutdown for PowerStore 500T

Table 20. High ambient temperature shutdown for AC

Ambient temperature	Hardware fault	Consequence
At or above 43°C (109°F)	None	The system generates a noncritical warning.
At or above 45°C (113°F)	None	The system generates a critical alert, and shuts down after a five minute timer expires. If the temperature returns to 39° C (102° F) or below, the system powers on.
Any	Two fans fault	The system shuts down after a five minute timer expires.

NOTE: If both nodes reach the critical ambient temperature, the system triggers a delayed shutdown. If the temperatures have not stabilized in 300 seconds, the system shuts down.

Table 21. High ambient temperature shutdown for DC

Ambient temperature	Hardware fault	Consequence
At or above 55°C (131°F)	None	The system generates a noncritical warning.
At or above 58°C (136°F)	None	The system generates a critical alert, and shuts down after a five minute timer expires. If the temperature returns to 39° C (102° F) or below, the system powers on.
Any	Two fans fault	The system shuts down after a five minute timer expires.

NOTE: If both nodes reach the critical ambient temperature, the system triggers a delayed shutdown. If the temperatures have not stabilized in 300 seconds, the system shuts down.

Power requirements for the NVMe expansion enclosure

Power requirements vary depending on system configuration, loading, and environmental conditions. The table below describes the maximum expected power draw. To estimate power consumption values for your specific environment, use the [Dell Power Calculator](#).

Table 22. Power requirements

Requirement	Description
AC line voltage	100 to 240 VAC +/- 10%, single-phase, 47 to 63 Hz
AC line current (operating maximum)	6.49 A max at 100 VAC
	3.31 A max at 200 VAC
Power consumption (operating maximum at 200 VAC)	663 VA (630 W)
Power factor	0.92 minimum at full load 100V/200V
Heat dissipation (operating maximum at 200 VAC)	2.27 x 10 ⁶ J/hr (2,150 Btu/hr)
In-rush current	82A max for 1/2 Line cycle per line cord at 200 VAC

Table 22. Power requirements (continued)

Requirement	Description
Startup surge current	100A Max for up to 125uSec
AC protection	15 A fuse on each power supply, both Line and Neutral
AC inlet type	IEC320-C14 appliance coupler, per power zone
Ride-through time	10-millisecond minimum
Current sharing	+/- 5% of full load between power supplies

Considerations for TLC and QLC drives

TLC drives retain data for up to 90 days while powered off. Data corruption may occur if the drives are powered off for more than 90 days. QLC drives retain data for up to 30 days while powered off. Data corruption may occur if the drives are powered off for more than 30 days. Data corruption may occur for either drive type if they are stored in temperatures above 40° C (104° F).

Operating environment limits

Table 23. Operating environment limits

Limit Type	Limit
Temperature	5°C through 35°C normal, 35°C through 40°C for 10% of the time
Humidity	-12°C DP and 8% to 85% RH (non-condensing)
Temperature Gradient (disk)	20°C/hr
Altitude Compensation	Normal: Lower temp 1°C per 300 M above 950 M
	Improbable: Lower temp 1°C per 175 M above 950 M

Shipping and storage requirements

⚠ CAUTION: Systems and components must not experience changes in temperature and humidity that are likely to cause condensation to form on or in that system or component. Do not exceed the shipping and storage temperature gradient of 45°F per hr (25°C per hr).

Table 24. Shipping and storage requirements

Requirement	Description
Ambient temperature	-40° F to 149°F (-40°C to 65°C)
Temperature gradient	45°F per hr (25°C per hr)
Relative humidity	10% to 90% noncondensing
Elevation	-50 ft to 35,000 ft (-16 m to 10,600 m)
Unpowered storage time	Do not exceed six consecutive months of unpowered storage.

Base enclosure airflow

The base enclosure uses an adaptive cooling algorithm that increases or decreases fan speed as the unit senses changes to the external ambient temperature. Exhaust increases with ambient temperature and fan speed, and is roughly linear within

recommended operating parameters. Note that the information in the table below is typical, and was measured without cabinet front/rear doors that would potentially reduce front-to-back air flow.

Table 25. Base enclosure airflow

Max Airflow CFM	Min Airflow CFM	Max Power Usage (Watts)
165 CFM	50 CFM	850 W

Environmental recovery

If the system exceeds the maximum ambient temperature by approximately 10°C (18°F), the nodes in the system begin an orderly shutdown that saves cached data, and then shut themselves down. Link control cards (LCCs) in each expansion enclosure in the system power down drives but remain powered on.

If the system detects that the temperature has dropped to an acceptable level, it restores power to the base enclosures and the LCCs restore power to their drives.

Air quality requirements

The products are designed to be consistent with the requirements of the American Society of Heating, Refrigeration and Air Conditioning Engineers (ASHRAE) Environmental Standard Handbook and the most current revision of Thermal Guidelines for Data Processing Environments, Second Edition, ASHRAE 2009b.

Cabinets are best suited for Class 1 datacom environments, which consist of tightly controlled environmental parameters, including temperature, dew point, relative humidity and air quality. These facilities house mission-critical equipment and are typically fault-tolerant, including the air conditioners.

The data center should maintain a cleanliness level as identified in ISO 14664-1, class 8 for particulate dust and pollution control. The air entering the data center should be filtered with a MERV 11 filter or better. The air within the data center should be continuously filtered with a MERV 8 or better filtration system. In addition, efforts should be maintained to prevent conductive particles, such as zinc whiskers, from entering the facility.

The allowable relative humidity level is 20 to 80% non condensing, however, the recommended operating environment range is 40 to 55%. For data centers with gaseous contamination, such as high sulfur content, lower temperatures and humidity are recommended to minimize the risk of hardware corrosion and degradation. In general, the humidity fluctuations within the data center should be minimized. It is also recommended that the data center be positively pressured and have air curtains on entry ways to prevent outside air contaminants and humidity from entering the facility.

For facilities below 40% relative humidity, it is recommended to use grounding straps when contacting the equipment to avoid the risk of Electrostatic discharge (ESD), which can harm electronic equipment.

As part of an ongoing monitoring process for the corrosiveness of the environment, it is recommended to place copper and silver coupons (per ISA 71.04-1985, Section 6.1 Reactivity), in airstreams representative of those in the data center. The monthly reactivity rate of the coupons should be less than 300 Angstroms. When monitored reactivity rate is exceeded, the coupon should be analyzed for material species and a corrective mitigation process put in place.

Storage time (unpowered) recommendation: do not exceed 6 consecutive months of unpowered storage.

Fire suppressant disclaimer

Fire prevention equipment in the computer room should always be installed as an added safety measure. A fire suppression system is the responsibility of the customer. When selecting appropriate fire suppression equipment and agents for the data center, choose carefully. An insurance underwriter, local fire marshal, and local building inspector are all parties that you should consult during the selection of a fire suppression system that provides the correct level of coverage and protection.

Equipment is designed and manufactured to internal and external standards that require certain environments for reliable operation. Compatibility claims and recommendations on fire suppression systems are not provided through Dell. It is not recommended to position storage equipment directly in the path of high-pressure gas discharge streams or loud fire sirens to minimize the forces and vibration adverse to system integrity.

NOTE: The previous information is provided on an as-is basis and provides no representations, warranties, guarantees, or obligations on the part of our company. This information does not modify the scope of any warranty set forth in the terms and conditions of the basic purchasing agreement between the customer and the manufacturer.

Shock and vibration

Products have been tested to withstand the shock and random vibration levels.

The levels apply to all three axes and should be measured with an accelerometer on the equipment enclosures within the cabinet and shall not exceed any of the values in this table.

Table 26. Platform Response Levels

Platform condition	Response measurement level
Nonoperational shock	25 Gs for 3-milliseconds
Operational shock	6 Gs for 11-milliseconds
Nonoperational random vibration	0.40 Grms at 5-500 Hz for 30 minutes
Operational random vibration	0.21 Grms at a frequency range between 5-500 Hz for 10 minutes

Systems that are mounted on an approved package have completed transportation testing to withstand shock and vibrations in the vertical direction only. The levels shall not exceed the values in this table.

Table 27. Packaged System Measurement Levels

Packaged system condition	Response measurement level
Transportation shock	10 Gs for 12-milliseconds
Transportation random vibration	0.28 Grms at a frequency range between 1-100 Hz for 4 hours