



Dell PowerEdge T130

Owner's Manual

註、警示與警告

 **註:**「註」表示可以幫助您更有效地使用產品的重要資訊。

 **警示:**「警示」表示有可能會損壞硬體或導致資料遺失，並告訴您如何避免發生此類問題。

 **警告:**「警告」表示有可能會導致財產損失、人身傷害甚至死亡。

2018 - 05

Rev. A06

Contents

1 About the Dell PowerEdge T130 system.....	8
Supported configurations on PowerEdge T130 systems.....	9
Front panel	10
Front panel features and indicators.....	10
Back panel features.....	11
背面板功能和指示燈.....	12
Diagnostic indicators.....	13
Diagnostic indicators on the front panel.....	13
Hard drive indicator codes.....	14
NIC indicator codes.....	15
電源供應器的電源指示燈代碼.....	16
Locating Service Tag of your system.....	16
說明文件對照表.....	17
2 說明文件資源.....	18
3 技術規格.....	20
Chassis dimensions.....	21
Chassis weight.....	21
Processor specifications.....	22
擴充匯流排規格.....	22
Memory specifications.....	22
電源規格.....	22
Storage controller specifications.....	23
磁碟機規格.....	23
Hard drives.....	23
Optical drive.....	23
連接埠和連接器規格.....	23
USB ports.....	23
NIC ports.....	24
iDRAC8.....	24
Serial connector.....	24
VGA ports.....	24
SD vFlash.....	24
Video specifications.....	24
Environmental specifications.....	25
4 Initial system setup and configuration.....	27
Setting up your system.....	27
iDRAC configuration.....	27
Options to set up iDRAC IP address.....	27
Options to install the operating system.....	28

Methods to download firmware and drivers.....	28
5 Pre-operating system management applications.....	30
Navigation keys.....	30
System Setup.....	31
進入系統設定.....	31
System Setup details.....	31
System BIOS Settings details.....	31
System Information details.....	32
Memory Settings details.....	32
Processor Settings details.....	33
SATA Settings details.....	34
Boot Settings details.....	35
Network Settings screen details.....	36
UEFI 設定畫面詳細資訊.....	36
Integrated Devices details.....	36
Serial Communication details.....	37
System Profile Settings details.....	38
System Security Settings details.....	38
Miscellaneous Settings details.....	40
有關 Boot Manager.....	41
Viewing Boot Manager.....	41
Boot Manager main menu.....	41
關於 Dell Lifecycle Controller.....	41
Changing the boot order.....	41
Choosing the 系統 boot mode.....	42
Creating a system or setup password.....	42
Using your 系統 password to secure your 系統.....	43
Deleting or changing 系統 and setup password.....	43
Operating with a setup password enabled.....	43
Embedded systems management.....	44
iDRAC Settings utility.....	44
Entering the iDRAC Settings utility.....	44
Changing the thermal settings.....	44
6 安裝和卸下系統元件.....	45
Safety instructions.....	45
拆裝系統內部元件之前.....	45
拆裝系統內部元件之後.....	45
建議的工具.....	45
System cover.....	46
Removing the system cover.....	46
Installing the system cover.....	47
前蓋.....	48
Removing the bezel.....	48
Installing the bezel.....	49

系統內部.....	50
侵入切換開關.....	50
Removing the intrusion switch.....	50
Installing the intrusion switch.....	51
Control panel.....	52
Removing the control panel assembly.....	52
Installing the control panel assembly.....	54
硬碟.....	55
Removing the hard drive cage.....	55
Installing the hard drive cage.....	56
Removing a hard drive carrier from the hard drive cage.....	57
Installing a hard drive carrier into the hard drive cage.....	59
Removing a hard drive carrier from the hard drive bay.....	60
Installing a hard drive carrier into the hard drive bay.....	61
Removing a hard drive from a hard drive carrier.....	62
Installing a hard drive into a hard drive carrier.....	63
硬碟佈線圖.....	64
設定 4 部 TB 硬碟的散熱風扇速度	65
光碟機.....	66
Removing the optical drive blank and filler.....	66
Installing the optical drive blank and filler.....	68
Removing the optical drive.....	70
Installing the optical drive.....	71
System memory.....	73
一般記憶體模組安裝指引.....	74
Sample memory configurations.....	74
卸下記憶體模組.....	75
安裝記憶體模組.....	76
散熱風扇.....	77
Removing the cooling fan.....	77
Installing the cooling fan.....	79
內部 USB 記憶體鑰匙 (可選).....	80
Replacing the optional internal USB memory key.....	80
擴充卡.....	81
擴充卡安裝指引.....	81
Removing an expansion card.....	82
Installing an expansion card.....	83
SD vFlash card (optional).....	84
Removing the optional SD vFlash card.....	84
Installing an optional SD vFlash card.....	85
iDRAC port card (optional).....	85
Removing the optional iDRAC port card.....	86
Installing the optional iDRAC port card.....	87
Processors and heat sinks.....	88
Removing the heat sink.....	89

Removing the processor.....	90
Installing the processor.....	92
安裝散熱器.....	94
電源供應器.....	96
Removing the power supply unit (PSU).....	96
Installing the power supply unit (PSU).....	97
System battery	98
Replacing the system battery.....	99
主機板.....	100
Removing the system board.....	100
Installing the system board.....	102
使用系統設定輸入系統服務標籤.....	104
Trusted Platform Module.....	104
Installing the Trusted Platform Module.....	105
Initializing the TPM for BitLocker users.....	105
Initializing the TPM for TXT users.....	106
7 Using system diagnostics.....	107
Dell Embedded System Diagnostics.....	107
When to use the Embedded System Diagnostics.....	107
Running the Embedded System Diagnostics from Boot Manager.....	107
Running the Embedded System Diagnostics from the Dell Lifecycle Controller.....	107
系統診斷程式控制.....	108
8 跳線與連接器.....	109
主機板跳線和連接器.....	109
System board jumper settings.....	110
停用忘記的密碼.....	111
9 故障排除您的系統.....	112
人身及系統安全至上.....	112
故障排除 系統 啟動故障.....	112
故障排除外部連線.....	113
故障排除影像子系統.....	113
故障排除 USB 裝置.....	113
故障排除序列輸入和輸出裝置.....	114
故障排除 NIC.....	114
故障排除受潮的系統.....	114
故障排除受損的系統.....	115
故障排除系統電池.....	116
故障排除電源供應器.....	116
故障排除電源問題.....	116
電源供應器問題.....	116
故障排除散熱問題.....	117
故障排除散熱風扇.....	117
故障排除系統記憶體.....	118

故障排除內部 USB 鑰匙.....	119
故障排除 Micro SD 卡.....	119
故障排除光碟機.....	120
故障排除磁碟機 或 SSD.....	120
故障排除儲存控制器.....	121
故障排除擴充卡.....	121
故障排除處理器.....	122
系統訊息.....	122
Warning messages.....	122
Diagnostic messages.....	122
Alert messages.....	123
10 獲得幫助.....	124
Contacting Dell.....	124
使用 QRL 存取系統資訊.....	124

About the Dell PowerEdge T130 system

The Dell PowerEdge T130 is a single socket rack server and supports the following hardware configuration:

Component	Quantity
Processor	The server supports one processor from these product families <ul style="list-style-type: none">• Intel E3-1200 v5 or v6 series• Intel Core i3 6100 series• Intel Celeron G3900 series• Intel Celeron G3930• Intel Pentium G4500 series• Intel Pentium G4600 series
Memory modules	Up to four DIMMS
Hard drives	Up to four 3.5 inch cabled hard drives

Topics:

- [Supported configurations on PowerEdge T130 systems](#)
- [Front panel](#)
- [Back panel features](#)
- [Diagnostic indicators](#)
- [Locating Service Tag of your system](#)
- [說明文件對照表](#)

Supported configurations on PowerEdge T130 systems

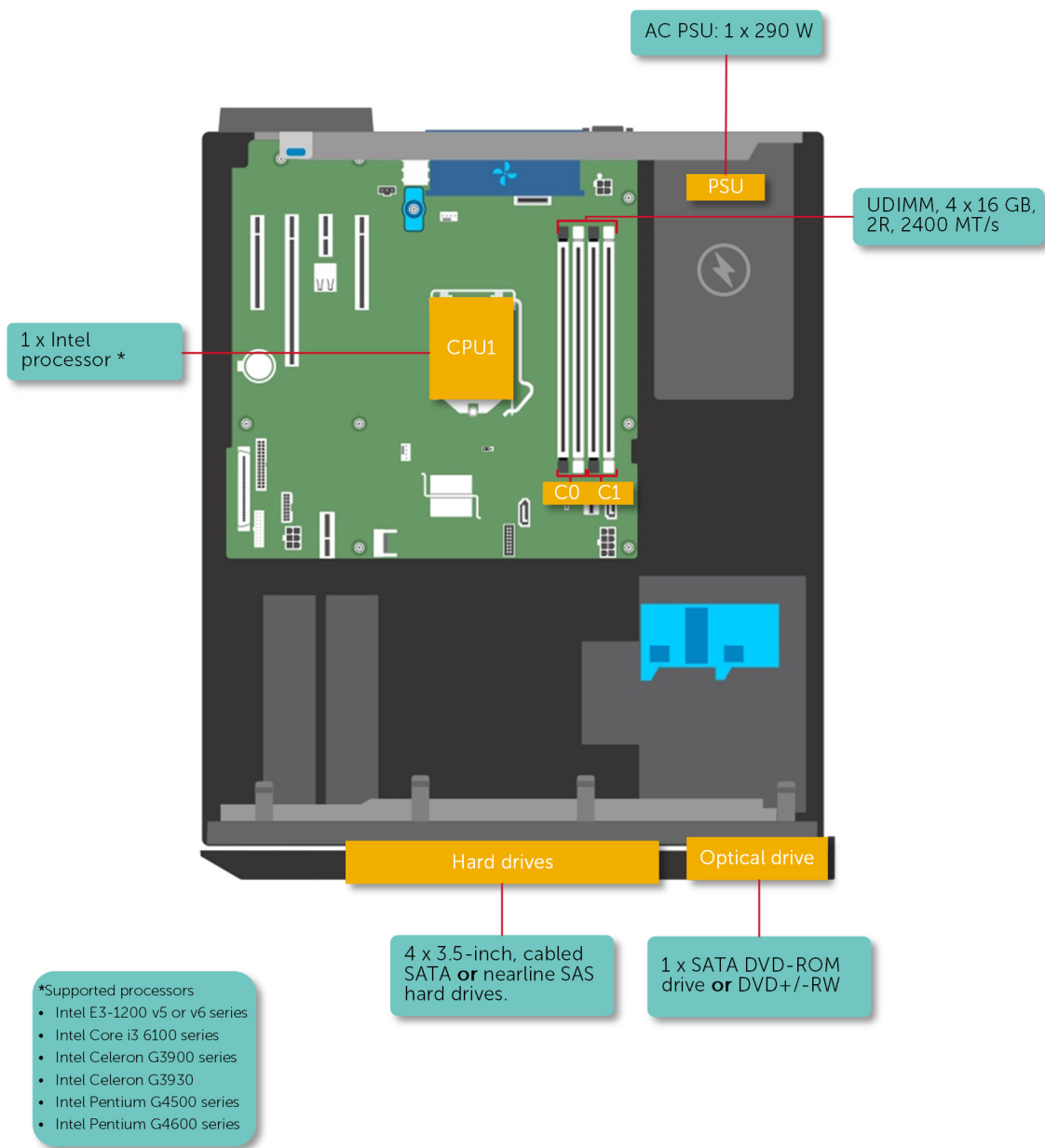

Figure 1. Supported configurations on PowerEdge T130 systems

Front panel

The front panel provides access to the features available on the front of the server, such as the power button, NMI button, system identification tag, system identification button, and USB and VGA ports. The diagnostic LEDs or the LCD panel is prominently located on the front panel. The hot swappable hard drives are accessible from the front panel.

Front panel features and indicators

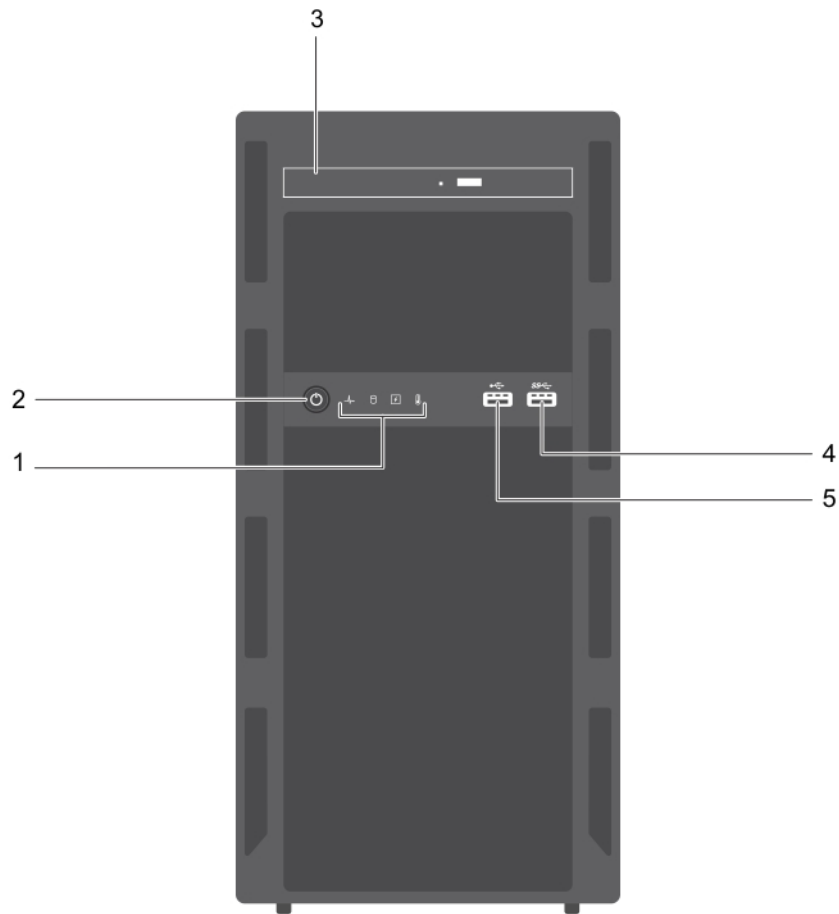





Figure 2. Front panel features and indicators

Table 1. Front panel features and indicators

Item	Indicator, button, or connector	Icon	Description
1	Diagnostic indicators		Enables you to view error status during system startup. The diagnostic indicators are located on the system front panel. For more information, see Diagnostic indicators on the front panel .
2	Power-on indicator, power button		Enables you to know the power status of the system. The power-on indicator glows when the system power is on. The power button controls the power supply output to the system.

Item	Indicator, button, or connector	Icon	Description
			<p>NOTE: On ACPI-compliant operating systems, turning off the system using the power button causes the system to perform a graceful shutdown before power to the system is turned off.</p>
3	Optical drive (optional)		Enables you to install an optional slim SATA DVD-ROM drive or DVD +/-RW drive.
4	USB connector		Enables you to connect USB devices to the system. This port is USB 3.0 compliant.
5	USB connector		Enables you to connect USB devices to the system. This port is USB 2.0 compliant.

Back panel features

The back panel provides access to the features available on the back of the server, such as the system identification button, power supply sockets, cable management arm connectors, iDRAC storage media, NIC ports, and USB and VGA ports. A majority of the expansion card ports can be accessed from the back panel. The hot swappable power supply units, and if installed, the rear accessible hard drives are accessible from the back panel.

背面板功能和指示燈





圖 3. 背面板功能和指示燈

表 2. 背面板功能和指示燈

項目	指示燈、按鈕或連接器	圖示	說明
1	USB 連接器 (6)		可讓您將 USB 裝置連接至系統。有四個 USB 2.0 相容連接埠和兩個 USB 3.0 相容連接埠。
2	乙太網路連接器 (2)		可讓您連接整合式 10/100/1000 Mbps NIC 連接器。
3	系統識別按鈕		<p>可讓您找到特定的系統。按下此按鈕，背面系統狀態指示燈會閃爍，直到再按一次按鈕。</p> <p>若要開啟或關閉系統 ID 指示燈，請按下系統識別按鈕。</p> <p>如果系統在 POST 期間停止回應，請按住系統 ID 按鈕五秒以上，以進入 BIOS 進度模式。</p>

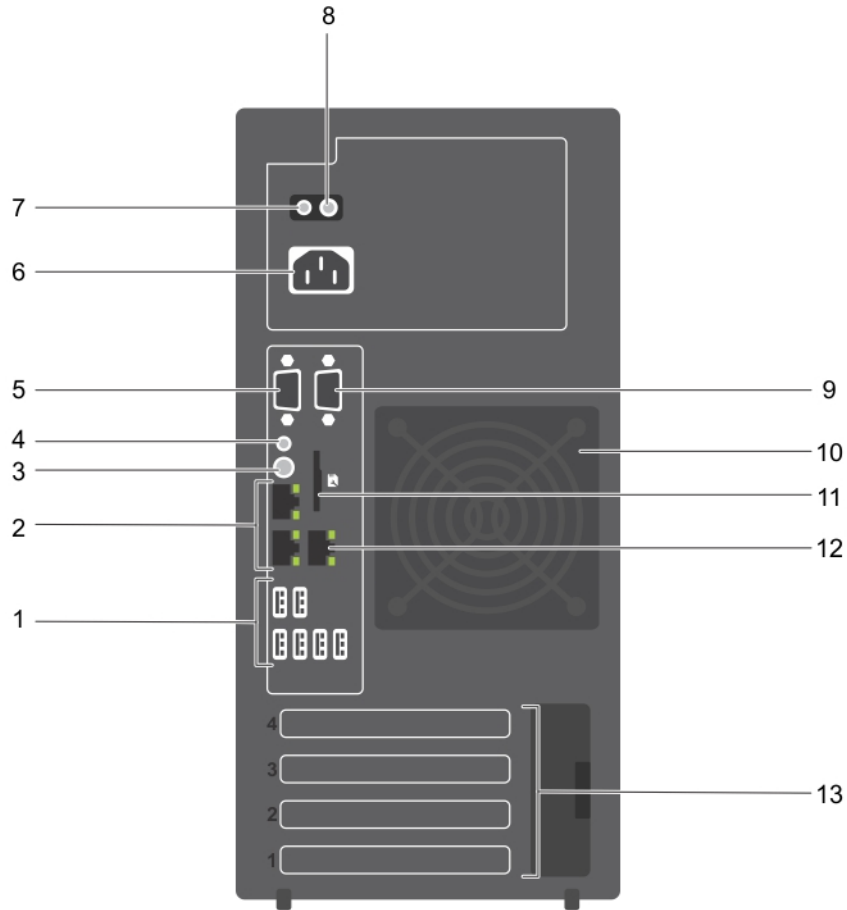
項目	指示燈、按鈕或連接器	圖示	說明
			若要重置 iDRAC (如果未在 F2 iDRAC 設定中停用), 請按住系統識別按鈕 15 秒以上。
4	系統識別連接器		可讓您透過選購的纜線管理臂連接選購的系統狀態指示燈組件。
5	影像連接器		可讓您將 VGA 顯示器連接至系統。
6	電源供應器		可讓您安裝一個 290W 非備援 AC PSU。
7	自我診斷按鈕		可讓您檢查 PSU 的健康狀況。
8	AC 電源供應狀態指示燈		可讓您檢查供應給 PSU 的電源。
9	序列連接器		可讓您將序列裝置連接至系統。
10	散熱風扇		系統散熱風扇。
11	VFlash		可讓您連接 vFlash 卡 (選購) 。
12	乙太網路連接器 (1)		可讓您安裝一個專屬的管理連接埠插卡 (選購) 。
13	擴充卡插槽 (4)		可讓您連接最多四個全高 PCIe 擴充卡。



Diagnostic indicators



The diagnostic indicators on the 系統 indicate operation and error status.

Diagnostic indicators on the front panel

NOTE: No diagnostic indicators are lit when the 系統 is turned off. To start the 系統, plug it into a working power source and press the power button.

Table 3. Diagnostic indicators

Icon	Description	Condition	Corrective action
	Health indicator	<p>The indicator turns solid blue if the 系統 is in good health.</p> <p>The indicator flashes amber:</p> <ul style="list-style-type: none"> When the 系統 is turned on. When the 系統 is in standby. If any error condition exists. For example, a failed fan, PSU, or a hard drive. 	<p>None required.</p> <p>Check the System Event Log or system messages for the specific issue. For more information about error messages, see the <i>Dell Event and Error Messages Reference Guide</i> at Dell.com/openmanagemanuals > OpenManage software.</p> <p>The POST process is interrupted without any video output due to invalid memory configurations. See the Getting help section.</p>
	Hard drive indicator	The indicator flashes amber if there is a hard drive error.	Check the System Event Log to determine the hard drive that has an error. Run the appropriate Online Diagnostics test. Restart the 系統 and run embedded diagnostics (ePSA). If the hard drives are configured in a RAID array,

Icon	Description	Condition	Corrective action
	Electrical indicator	The indicator flashes amber if the 系統 experiences an electrical error (for example, voltage out of range, or a failed power supply unit (PSU) or voltage regulator).	restart the 系統 and enter the host adapter configuration utility program. Check the System Event Log or system messages for the specific issue. If it is due to a problem with the PSU, check the LED on the PSU. Reseat the PSU. If the problem persists, see the Getting help section.
	Temperature indicator	The indicator flashes amber if the 系統 experiences a thermal error (for example, the ambient temperature is out of range or fan failure).	Ensure that none of the following conditions exist: <ul style="list-style-type: none"> • A cooling fan has been removed or has failed. • System cover, memory module blank, or back filler bracket is removed. • Ambient temperature is too high. • External airflow is obstructed. See the Getting help section.
	PCIe indicator	The indicator flashes amber if a PCIe card experiences an error.	Restart the 系統. Update any required drivers for the PCIe card. Reinstall the card. If the problem persists, see the Getting help section.

Hard drive indicator codes

Each hard drive carrier has an activity indicator and a status indicator. The indicators provide information about the current status of the hard drive. The activity LED indicates whether hard drive is currently in use or not. The status LED indicates the power condition of the hard drive.



Figure 4. Hard drive indicators

- | | | | |
|---|-------------------------------|---|-----------------------------|
| 1 | Hard drive activity indicator | 2 | Hard drive status indicator |
| 3 | Hard drive | | |

Table 5. NIC indicators

Convention	Status	Condition
A	Link and activity indicators are off	The NIC is not connected to the network.
B	Link indicator is green	The NIC is connected to a valid network at its maximum port speed (1 Gbps or 10 Gbps).
C	Link indicator is amber	The NIC is connected to a valid network at less than its maximum port speed.
D	Activity indicator is flashing green	Network data is being sent or received.

電源供應器的電源指示燈代碼

按下自我診斷按鈕，執行系統電源供應器 (PSU) 的健全狀況快速檢查。



圖 6. 電源供應器狀態指示燈和自我診斷按鈕

1 自我診斷按鈕

2 電源供應器狀態指示燈

電源供應器狀態 狀況 指示燈

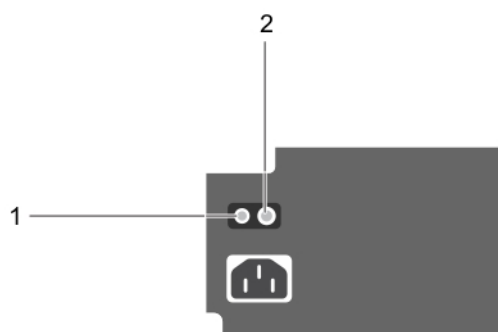
未亮起 電源未連接或電源供應器故障。

綠色 有效的電源來源已連接至電源供應器，同時電源供應器為可運作。

Locating Service Tag of your system

Your system is identified by a unique Express Service Code and Service Tag number. The Express Service Code is and Service Tag are found on the front of the system by pulling out the information tag. Alternatively, the information may be on a sticker on the chassis of the system. This information is used by Dell to route support calls to the appropriate personnel.

Your system is identified by a unique Express Service Code and Service Tag number. The Express Service Code is and Service Tag are found on the front of the system by pulling out the information tag. Alternatively, the information may be on a sticker on the chassis of the system. This information is used by Dell to route support calls to the appropriate personnel.

說明文件對照表

說明文件對照表就您可參考的系統設定與管理文件提供相關資訊。

表 6. 說明文件對照表

若要...	參閱...
將系統安裝至機架中	機架解決方案隨附的機架說明文件
設定系統及了解系統技術規格	系統隨附的 <i>系統入門</i> 或參閱 Dell.com/poweredgemanuals
安裝作業系統	作業系統說明文件位於 Dell.com/operatingsystemmanuals
獲得 Dell Systems Management 產品與服務的概觀	<i>Dell OpenManage Systems Management Overview 指南</i> 位於 Dell.com/openmanagemanuals > OpenManage software
設定及登入 iDRAC、設定受管理的系統與管理系統、了解 iDRAC 功能及使用 iDRAC 排除故障	<i>Integrated Dell Remote Access Controller 使用者指南</i> 位於 Dell.com/idracmanuals
了解 RACADM 子命令與支援的 RACADM 介面	<i>iDRAC 的 RACADM 命令列參考指南</i> 位於 Dell.com/idracmanuals
啟動、啟用及停用 Lifecycle Controller、了解功能、使用 Lifecycle Controller 及排除故障	<i>Dell Lifecycle Controller 使用者指南</i> 位於 Dell.com/idracmanuals
使用 Lifecycle Controller 遠端服務	<i>Dell Lifecycle Controller 快速啟動指南</i> 位於 Dell.com/idracmanuals
設定、使用及故障排除 OpenManage Server Administrator	<i>Dell OpenManage Server Administrator 使用者指南</i> 位於 Dell.com/openmanagemanuals > OpenManage Server Administrator
安裝、使用及故障排除 OpenManage Essentials	<i>Dell OpenManage Essentials 使用者指南</i> 位於 Dell.com/openmanagemanuals > OpenManage Essentials
了解儲存控制器卡的功能、部署控制器卡及管理儲存子系統	儲存控制器說明文件位於 Dell.com/storagecontrollermanuals
查看監視系統元件之系統韌體與代理程式所產生的事件與錯誤訊息	<i>Dell 的事件與錯誤訊息參考指南</i> 位於 Dell.com/openmanagemanuals > OpenManage software

說明文件資源

本節提供有關您系統說明文件資源的資訊。

表 7. 您系統的其他使用說明文件

工作	文件	Location (位置)	
設定您的系統	如需將系統安裝及固定至機架中的詳細資訊，請參閱機架解決方案隨附的機架說明文件。	Dell.com/poweredgemanuals	
	如需有關設定與開啟系統的資訊，請參閱系統隨附的入門指南文件。	Dell.com/poweredgemanuals	
設定您的系統	如需 iDRAC 功能、設定與登入 iDRAC，以及遠端管理系統的相關資訊，請參閱 Integrated Dell Remote Access Controller 使用者指南。	Dell.com/idracmanuals	
	如需有關安裝作業系統的資訊，請參閱作業系統說明文件。	Dell.com/operatingsystemmanuals	
	如需瞭解遠端存取控制器管理員 (RACADM) 子命令，以及受支援 RACADM 介面的相關資訊，請參閱 iDRAC 的 RACADM 命令列參考指南。	Dell.com/idracmanuals	
	如需有關更新驅動程式和韌體的資訊，請參閱本文件中下載韌體和驅動程式方法的章節。	若要下載驅動程式，請至： Dell.com/support/drivers	
管理您的系統	如需有關 Dell 所提供的系統管理軟體之資訊，請參閱 Dell OpenManage 系統管理概觀指南。	Dell.com/openmanagemanuals	
	如需有關設定、使用及 OpenManage 故障排除的資訊，請參閱 Dell OpenManage Server 管理員使用者指南。	Dell.com/openmanagemanuals	
	如需有關安裝、使用及 Dell OpenManage Essentials 故障排除的資訊，請參閱 Dell OpenManage Server 使用者指南。	Dell.com/openmanagemanuals	
	如需有關安裝和使用 Dell SupportAssist 的資訊，請參閱 Dell EMC SupportAssist Enterprise 使用者指南。	Dell.com/serviceabilitytools	
	如需瞭解 Dell Lifecycle Controller 的功能，請參閱 Dell Lifecycle Controller 使用者指南。	Dell.com/idracmanuals	
	如需有關合作夥伴專案企業系統管理的資訊，請參閱 OpenManage Connections 企業系統管理文件。	Dell.com/openmanagemanuals	
	使用 Dell PowerEdge RAID 控制器	如需瞭解 Dell PowerEdge RAID 控制器 (PERC)、Software RAID 控制器，或 BOSS 卡以及如何部	Dell.com/storagecontrollermanuals

工作	文件	Location (位置)
瞭解事件與錯誤訊息	<p>署這些卡的相關資訊，請參閱儲存控制器的說明文件</p> <p>如需監視系統元件之系統韌體和代理程式產生的事件和錯誤訊息的相關資訊，請參閱 Dell 事件與錯誤訊息參考指南。</p>	<p>Dell.com/openmanagemanuals > OpenManage software (OpenManage 軟體)</p>
故障排除您的系統	<p>如需有關識別及對 PowerEdge 伺服器問題進行故障排除的資訊，請參閱伺服器故障排除指南。</p>	<p>Dell.com/poweredgemanuals</p>

技術規格

主題：

- Chassis dimensions
- Chassis weight
- Processor specifications
- 擴充匯流排規格
- Memory specifications
- 電源規格
- Storage controller specifications
- 磁碟機規格
- 連接埠和連接器規格
- Video specifications
- Environmental specifications

Chassis dimensions

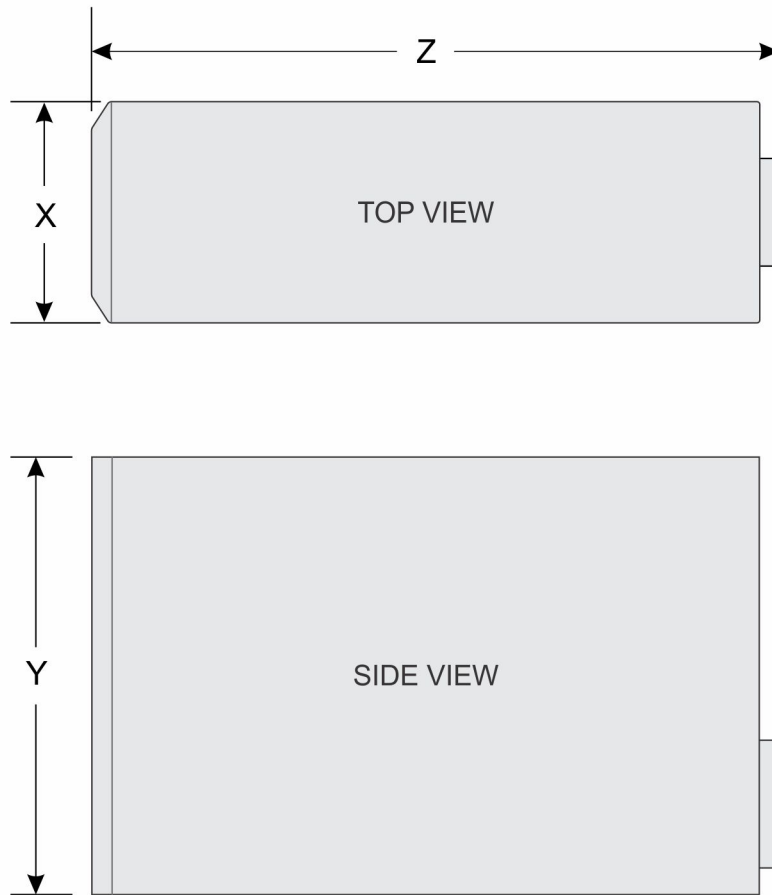

Figure 7. Chassis dimensions of the PowerEdge T130 system

Table 8. Dimensions of the PowerEdge T130 system

X	Y	Z
175.1 mm (6.89 inches)	362.5 mm (14.27 inches) with rubber feet	453.75 mm (17.86 inches)

Chassis weight

Table 9. Chassis weight

System	Maximum weight (with all hard drives)
PowerEdge T130	11.1 kg (24.47 lb)

Processor specifications

Processor	Specification
Type	The PowerEdge T130 supports any one of the processors listed here: <ul style="list-style-type: none">• Intel E3-1200 v5 or v6 series• Intel Core i3 6100 series• Intel Celeron G3900 series• Intel Celeron G3930• Intel Pentium G4500 series• Intel Pentium G4600 series

擴充匯流排規格

PCI Express 擴充插槽	規格
插槽 1	連接至處理器的一個全高、半長 x4 PCIe 第 3 代卡插槽
插槽 2	連接至處理器的一個全高、半長 x8 PCIe 第 3 代卡插槽
插槽 3	連接至平台控制器集線器 (PCH) 的一個全高、全長 x1 PCIe 第 3 代卡插槽
插槽 4	連接至 PCH 的一個全高、全長 x4 PCIe 第 3 代卡插槽

Memory specifications

Memory	Specification
Architecture	1600 MT/s, 1866 MT/s, 2133 MT/s, or 2400 MT/s DDR4 Unbuffered DIMMs Support for advanced ECC or memory optimized operation
Memory module sockets	Four 288-pin sockets
Memory module capacities (UDIMM)	4 GB (single-rank), 8 GB (single- and dual-rank), 16 GB (single- and dual-rank)
Minimum RAM	4 GB
Maximum RAM	64 GB

電源規格

電源供應器	規格
每個電源供應器功率	290W (銅) 交流電 (100–240 V, 50/60 Hz, 5.4 A)
散熱	989BTU/hr 最大 (290W 電源供應器)

 註: 使用電源供應器額定瓦特數計算散熱量。

電源供應器

規格

電壓

100–240 V AC · 自動調整 · 50/60 Hz

 註: 本系統亦可連接 IT 電源系統 · 該系統的相位間電壓不得超過 230 V。

Storage controller specifications

Storage controller

Specification

Storage controller type

PERC H730, PERC H330, PERC H830, PERC S130.

 **NOTE: Your system supports software RAID S130 and a PERC card.**

For more information on software RAID, see the Dell PowerEdge RAID Controller (PERC) documentation at Dell.com/storagecontrollermanuals.

 **NOTE: The upgrade from embedded controller or Software RAID controller to Hardware RAID controller is not supported.**

磁碟機規格

Hard drives

The PowerEdge T130 system supports SAS, SATA, and Nearline SAS hard drives.

Drives

Specification

Four hard drive system

Up to four 3.5-inch, internal, cabled SATA and nearline SAS hard drives.

 **NOTE: NOTE: The PowerEdge T130 does not support hard drives higher than 5 TB.**

Optical drive

The PowerEdge T130 system supports one optional SATA DVD-ROM drive or DVD+/-RW drive.

連接埠和連接器規格

USB ports

The PowerEdge T130 system supports:

- USB 2.0-compliant ports on the front panel
- USB 3.0-compliant and USB 2.0-compliant ports on the back panel
- USB 3.0-compliant internal port

The following table provides more information about the USB specifications:

Table 10. USB specifications

System	Front panel	Back panel	Internal
PowerEdge T130	Two 4-pin, USB 2.0-compliant ports	Two 9-pin, USB 3.0-compliant port Four 4-pin, USB 2.0-compliant port	One 9-pin, USB 3.0-compliant port

NIC ports

The PowerEdge T130 system supports two 10/100/1000 Mbps Network Interface Controller (NIC) ports on the back panel.

iDRAC8

The PowerEdge T130 system supports one optional dedicated 1 GbE Ethernet on the iDRAC Enterprise port card.

Serial connector

The serial connector connects a serial device to the system. The PowerEdge T130 system supports one serial connector on the back panel, which is a 9-pin connector, Data Terminal Equipment (DTE), 16550-compliant.

VGA ports

The Video Graphic Array (VGA) port enables you to connect the system to a VGA display. The PowerEdge T130 system supports one 15-pin VGA port on the back panel.

SD vFlash

The PowerEdge T130 system supports one optional SD vFlash memory card on the iDRAC Enterprise port card.

NOTE: The card slot is available for use only if the iDRAC8 Enterprise license is installed on your system.

Video specifications

The PowerEdge T130 system supports Integrated Matrox G200 with iDRAC8 and 16 MB application memory.

Table 11. Supported video resolution options

Resolution	Refresh Rate (Hz)	Color Depth (bit)
640 x 480	60, 70	8, 16, 24
800 x 600	60, 75, 85	8, 16, 24
1024 x 768	60, 75, 85	8, 16, 24

Resolution	Refresh Rate (Hz)	Color Depth (bit)
1152 x 864	60, 75, 85	8, 16, 24
1280 x 1024	60, 75	8, 16, 24

Environmental specifications

NOTE: For additional information about environmental measurements for specific system configurations, see [Dell.com/environmental_datasheets](https://www.dell.com/environmental_datasheets).

Temperature Specifications

Storage	−40°C to 65°C (−40°F to 149°F)
Continuous operation (for altitude less than 950 m or 3117 ft)	10°C to 35°C (50°F to 95°F) with no direct sunlight on the equipment.
Maximum temperature gradient (operating and storage)	20°C/h (68°F/h)

Relative humidity Specifications

Storage	5% to 95% RH with 33°C (91°F) maximum dew point. Atmosphere must be non-condensing at all times.
Operating	10% to 80% Relative Humidity with 29°C (84.2°F) maximum dew point.

Maximum vibration Specifications

Operating	0.26 G _{rms} at 5 Hz to 350 Hz (operation orientation).
Storage	1.88 G _{rms} at 10 Hz to 500 Hz for 15 min (all six sides tested).

Maximum shock Specifications

Operating	Six consecutively executed shock pulses in the positive and negative x, y, and z axes of 31G for up to 2.6 ms.
Storage	Six consecutively executed shock pulses in the positive and negative x, y, and z axes (one pulse on each side of the system) of 71 G for up to 2 ms.

Maximum altitude Specifications

Operating	m (ft).
Storage	12,000 m (39,370 ft).

Operating temperature de-rating Specifications

Up to 35 °C (95 °F)	Maximum temperature is reduced by 1°C/300 m (33.8°F/984.25 ft) above 950 m (3,117 ft)
---------------------	---

The following section defines the limits to help avoid IT equipment damage and/or failure from particulates and gaseous contamination. If the levels of particulates or gaseous pollution are beyond the specified limits and cause equipment damage or failure, you may need to rectify the environmental conditions. Remediation of environmental conditions is the responsibility of the customer.

Particulate contamination

Specifications

Air filtration

Data center air filtration as defined by ISO Class 8 per ISO 14644-1 with a 95% upper confidence limit.

NOTE: Applies to data center environments only. Air filtration requirements do not apply to IT equipment designed to be used outside a data center, in environments such as an office or factory floor.

NOTE: Air entering the data center must have MERV11 or MERV13 filtration.

Conductive dust

Air must be free of conductive dust, zinc whiskers, or other conductive particles.

NOTE: Applies to data center and non-data center environments.

Corrosive dust

- Air must be free of corrosive dust.
- Residual dust present in the air must have a deliquescent point less than 60% relative humidity.

NOTE: Applies to data center and non-data center environments.

Gaseous contamination

Specifications

Copper coupon corrosion rate

<300 Å/month per Class G1 as defined by ANSI/ISA71.04-1985.

Silver coupon corrosion rate

<200 Å/month as defined by AHSRAE TC9.9.

NOTE: Maximum corrosive contaminant levels measured at ≤50% relative humidity.

Initial system setup and configuration

Setting up your system

Complete the following steps to set up your system:

- 1 Unpack the system.
- 2 Install the system into the rack. For more information about installing the system into the rack, see your system *Rack Installation Placemat* at [Dell.com/poweredge/manuals](https://www.dell.com/poweredge/manuals).
- 3 Connect the peripherals to the system.
- 4 Connect the system to its electrical outlet.
- 5 Turn the system on by pressing the power button or by using iDRAC.
- 6 Turn on the attached peripherals.

iDRAC configuration

The Integrated Dell Remote Access Controller (iDRAC) is designed to make 系統 administrators more productive and improve the overall availability of Dell EMC 系統. iDRAC alerts administrators to 系統 issues, helps them perform remote 系統 management, and reduces the need for physical access to the 系統.

Options to set up iDRAC IP address

You must configure the initial network settings based on your network infrastructure to enable the communication to and from iDRAC. You can set up the IP address by using one of the following interfaces:

Interfaces	Document/Section
iDRAC Settings utility	See <i>Dell Integrated Dell Remote Access Controller User's Guide</i> at Dell.com/idrac/manuals
Dell Deployment Toolkit	See <i>Dell Deployment Toolkit User's Guide</i> at Dell.com/openmanagement/manuals
Dell Lifecycle Controller	See <i>Dell Lifecycle Controller User's Guide</i> at Dell.com/idrac/manuals
Chassis or Server LCD panel	See the LCD panel section

You must use the default iDRAC IP address 192.168.0.120 to configure the initial network settings, including setting up DHCP or a static IP for iDRAC.

- NOTE:** To access iDRAC, ensure that you install the iDRAC port card or connect the network cable to the Ethernet connector 1 on the system board.
- NOTE:** Ensure that you change the default user name and password after setting up the iDRAC IP address.

Log in to iDRAC

You can log in to iDRAC as:

- iDRAC user
- Microsoft Active Directory user
- Lightweight Directory Access Protocol (LDAP) user

The default user name and password are `root` and `calvin`. You can also log in by using Single Sign-On or Smart Card.

NOTE: You must have iDRAC credentials to log in to iDRAC.

For more information about logging in to iDRAC and iDRAC licenses, see the latest Integrated Dell Remote Access Controller User's Guide at [Dell.com/idracmanuals](https://www.dell.com/idracmanuals).

Options to install the operating system

If the system is shipped without an operating system, install the supported operating system by using one of the following resources:

Table 12. Resources to install the operating system

Resources	Location
Dell Systems Management Tools and Documentation media	Dell.com/operatingsystemmanuals
Dell Lifecycle Controller	Dell.com/idracmanuals
Dell OpenManage Deployment Toolkit	Dell.com/openmanagemanuals
Dell certified VMware ESXi	Dell.com/virtualizationsolutions
Supported operating systems on Dell PowerEdge systems	Dell.com/ossupport
Installation and How-to videos for supported operating systems on Dell PowerEdge systems	Supported Operating Systems for Dell PowerEdge Systems

Methods to download firmware and drivers

You can download the firmware and drivers by using any of the following methods:

Table 13. Firmware and drivers

Methods	Location
From the Dell Support site	Dell.com/support/home
Using Dell Remote Access Controller Lifecycle Controller (iDRAC with LC)	Dell.com/idracmanuals
Using Dell Repository Manager (DRM)	Dell.com/openmanagemanuals
Using Dell OpenManage Essentials (OME)	Dell.com/openmanagemanuals
Using Dell Server Update Utility (SUU)	Dell.com/openmanagemanuals
Using Dell OpenManage Deployment Toolkit (DTK)	Dell.com/openmanagemanuals

Downloading the drivers and firmware

Dell recommends that you download and install the latest BIOS, drivers, and systems management firmware on your system.

Prerequisite

Ensure that you clear the web browser cache before downloading the drivers and firmware.

Steps

- 1 Go to Dell.com/support/drivers.
- 2 In the **Drivers & Downloads** section, type the Service Tag of your system in the **Service Tag or Express Service Code** box, and then click **Submit**.

 **NOTE:** If you do not have the Service Tag, select **Detect My Product** to allow the system to automatically detect your Service Tag, or in **General support**, navigate to your product.

- 3 Click **Drivers & Downloads**.
The drivers that are applicable to your selection are displayed.
- 4 Download the drivers to a USB drive, CD, or DVD.

Pre-operating system management applications

You can manage basic settings and features of a 系統 without booting to the operating system by using the 系統 firmware.

Topics:

- Navigation keys
- System Setup
- 有關 Boot Manager
- 關於 Dell Lifecycle Controller
- Changing the boot order
- Choosing the 系統 boot mode
- Creating a system or setup password
- Using your 系統 password to secure your 系統
- Deleting or changing 系統 and setup password
- Operating with a setup password enabled
- Embedded systems management
- iDRAC Settings utility

Navigation keys

The navigation keys can help you quickly access the pre-operating system management applications.

Table 14. Navigation keys

Key	Description
<Page Up>	Moves to the previous screen.
<Page Down>	Moves to the next screen.
Up arrow	Moves to the previous field.
Down arrow	Moves to the next field.
<Enter>	Enables you to type a value in the selected field (if applicable) or follow the link in the field.
Spacebar	Expands or collapses a drop-down list, if applicable.
<Tab>	Moves to the next focus area.
	NOTE: This feature is applicable for the standard graphic browser only.
<Esc>	Moves to the previous page until you view the main screen. Pressing <Esc> in the main screen exits System BIOS or iDRAC Settings/ Device Settings/Service Tag Settings and proceeds with system boot.
<F1>	Displays the System Setup help.

System Setup

By using the **System Setup** screen, you can configure the BIOS settings, iDRAC settings, and device settings of your 系統.

① **NOTE: Help text for the selected field is displayed in the graphical browser by default. To view the help text in the text browser, press F1.**

You can access system setup by using two methods:

- Standard graphical browser — The browser is enabled by default.
- Text browser — The browser is enabled by using Console Redirection.

進入系統設定

- 1 開啟或重新啟動您的系統。
- 2 在看到以下訊息時，立即按下 F2：

F2 = System Setup

如果在您按下 F2 之前，您的作業系統就已開始載入，請讓系統完成啟動，然後再重新啟動系統並重試。

System Setup details

The **System Setup Main Menu** screen details are explained as follows:

Option	Description
System BIOS	Enables you to configure BIOS settings.
iDRAC Settings	Enables you to configure iDRAC settings. The iDRAC settings utility is an interface to set up and configure the iDRAC parameters by using UEFI (Unified Extensible Firmware Interface). You can enable or disable various iDRAC parameters by using the iDRAC settings utility. For more information about this utility, see <i>Integrated Dell Remote Access Controller User's Guide</i> at Dell.com/idracmanuals .
Device Settings	Enables you to configure device settings.

System BIOS Settings details

The **System BIOS Settings** screen details are explained as follows:

Option	Description
System Information	Specifies information about the 系統 such as the 系統 model name, BIOS version, and Service Tag.
Memory Settings	Specifies information and options related to the installed memory.
Processor Settings	Specifies information and options related to the processor such as speed and cache size.
SATA Settings	Specifies options to enable or disable the integrated SATA controller and ports.
Boot Settings	Specifies options to specify the boot mode (BIOS or UEFI). Enables you to modify UEFI and BIOS boot settings.
Network Settings	Specifies options to change the network settings.

Option	Description
Integrated Devices	Specifies options to manage integrated device controllers and ports and specify related features and options.
Serial Communication	Specifies options to manage the serial ports and specify related features and options.
System Profile Settings	Specifies options to change the processor power management settings, memory frequency, and so on.
System Security	Specifies options to configure the system security settings, such as 系統 password, setup password, Trusted Platform Module (TPM) security. It also manages the power and NMI buttons on the 系統.
Miscellaneous Settings	Specifies options to change the 系統 date, time, and so on.

System Information details

The **System Information** screen details are explained as follows:

Option	Description
System Model Name	Specifies the 系統 model name.
System BIOS Version	Specifies the BIOS version installed on the 系統.
System Management Engine Version	Specifies the current version of the Management Engine firmware.
System Service Tag	Specifies the 系統 Service Tag.
System Manufacturer	Specifies the name of the 系統 manufacturer.
System Manufacturer Contact Information	Specifies the contact information of the 系統 manufacturer.
System CPLD Version	Specifies the current version of the 系統 complex programmable logic device (CPLD) firmware.
UEFI Compliance Version	Specifies the UEFI compliance level of the 系統 firmware.

Memory Settings details

The **Memory Settings** screen details are explained as follows:

Option	Description
System Memory Size	Specifies the memory size in the 系統.
System Memory Type	Specifies the type of memory installed in the 系統.
System Memory Speed	Specifies the memory speed.

Option	Description
System Memory Voltage	Specifies the memory voltage.
Video Memory	Specifies the amount of video memory.
System Memory Testing	Specifies whether the memory tests are run during 系統 boot. Options are Enabled and Disabled . This option is set to Disabled by default.
Memory Operating Mode	Specifies the memory operating mode. The available option is Optimizer Mode .

Processor Settings details

The **Processor Settings** screen details are explained as follows:

Option	Description
Logical Processor	Enables or disables the logical processors and displays the number of logical processors. If this option is set to Enabled , the BIOS displays all the logical processors. If this option is set to Disabled , the BIOS displays only one logical processor per core. This option is set to Enabled by default.
GPI Speed	Enables you to control QuickPath Interconnect data rate settings.
Virtualization Technology	Enables or disables the additional hardware capabilities provided for virtualization. This option is set to Enabled by default.
Adjacent Cache Line Prefetch	Optimizes the 系統 for applications that need high utilization of sequential memory access. This option is set to Enabled by default. You can disable this option for applications that need high utilization of random memory access.
Hardware Prefetcher	Enables or disables the hardware prefetcher. This option is set to Enabled by default.
DCU Streamer Prefetcher	Enables or disables the Data Cache Unit (DCU) streamer prefetcher. This option is set to Enabled by default.
DCU IP Prefetcher	Enables or disables the Data Cache Unit (DCU) IP prefetcher. This option is set to Enabled by default.
Configurable TDP	Enables you to reconfigure the processor Thermal Design Power (TDP) levels during POST based on the power and thermal delivery capabilities of the 系統. TDP verifies the maximum heat the cooling 系統 is needed to dissipate. This option is set to Nominal by default. NOTE: This option is only available on certain stock keeping units (SKUs) of the processors.
X2Apic Mode	Enables or disables the X2Apic mode.
Dell Controlled Turbo	Controls the turbo engagement. Enable this option only when System Profile is set to Performance . NOTE: Depending on the number of installed CPUs, there may be up to four processor listings.
Number of Cores per Processor	Controls the number of enabled cores in each processor. This option is set to All by default.
Processor 64-bit Support	Specifies if the processor(s) support 64-bit extensions.
Processor Core Speed	Specifies the maximum core frequency of the processor.
Processor 1	The following settings are displayed for each processor installed in the 系統:

Option	Description
Option	Description
Family-Model-Stepping	Specifies the family, model, and stepping of the processor as defined by Intel.
Brand	Specifies the brand name.
Level 2 Cache	Specifies the total L2 cache.
Level 3 Cache	Specifies the total L3 cache.
Number of Cores	Specifies the number of cores per processor.

SATA Settings details

The **SATA Settings** screen details are explained as follows:

Option	Description
Embedded SATA	Enables the embedded SATA option to be set to Off , AHCI , or RAID modes. This option is set to AHCI by default.
Security Freeze Lock	Sends Security Freeze Lock command to the Embedded SATA drives during POST. This option is applicable only for AHCI mode.
Write Cache	Enables or disables the command for Embedded SATA drives during POST.
Port A	For AHCI or RAID mode, BIOS support is always enabled.

Option	Description
Model	Specifies the drive model of the selected device.
Drive Type	Specifies the type of drive attached to the SATA port.
Capacity	Specifies the total capacity of the hard drive. This field is undefined for removable media devices such as optical drives.

Port B For **AHCI** or **RAID** mode, BIOS support is always enabled.

Option	Description
Model	Specifies the drive model of the selected device.
Drive Type	Specifies the type of drive attached to the SATA port.
Capacity	Specifies the total capacity of the hard drive. This field is undefined for removable media devices such as optical drives.

Port C For **AHCI** or **RAID** mode, BIOS support is always enabled.





Option	Description
Model	Specifies the drive model of the selected device.
Drive Type	Specifies the type of drive attached to the SATA port.
Capacity	Specifies the total capacity of the hard drive. This field is undefined for removable media devices such as optical drives.

Option	Description								
Port D	For AHCI or RAID mode, BIOS support is always enabled.								
	<table border="1"> <thead> <tr> <th>Option</th> <th>Description</th> </tr> </thead> <tbody> <tr> <td>Model</td> <td>Specifies the drive model of the selected device.</td> </tr> <tr> <td>Drive Type</td> <td>Specifies the type of drive attached to the SATA port.</td> </tr> <tr> <td>Capacity</td> <td>Specifies the total capacity of the hard drive. This field is undefined for removable media devices such as optical drives.</td> </tr> </tbody> </table>	Option	Description	Model	Specifies the drive model of the selected device.	Drive Type	Specifies the type of drive attached to the SATA port.	Capacity	Specifies the total capacity of the hard drive. This field is undefined for removable media devices such as optical drives.
Option	Description								
Model	Specifies the drive model of the selected device.								
Drive Type	Specifies the type of drive attached to the SATA port.								
Capacity	Specifies the total capacity of the hard drive. This field is undefined for removable media devices such as optical drives.								

Port E	For AHCI or RAID mode, BIOS support is always enabled.								
	<table border="1"> <thead> <tr> <th>Option</th> <th>Description</th> </tr> </thead> <tbody> <tr> <td>Model</td> <td>Specifies the drive model of the selected device.</td> </tr> <tr> <td>Drive Type</td> <td>Specifies the type of drive attached to the SATA port.</td> </tr> <tr> <td>Capacity</td> <td>Specifies the total capacity of the hard drive. This field is undefined for removable media devices such as optical drives.</td> </tr> </tbody> </table>	Option	Description	Model	Specifies the drive model of the selected device.	Drive Type	Specifies the type of drive attached to the SATA port.	Capacity	Specifies the total capacity of the hard drive. This field is undefined for removable media devices such as optical drives.
Option	Description								
Model	Specifies the drive model of the selected device.								
Drive Type	Specifies the type of drive attached to the SATA port.								
Capacity	Specifies the total capacity of the hard drive. This field is undefined for removable media devices such as optical drives.								

Boot Settings details

The **Boot Settings** screen details are explained as follows:

Option	Description
Boot Mode	<p>Enables you to set the boot mode of the 系統.</p> <p> CAUTION: Switching the boot mode may prevent the 系統 from booting if the operating system is not installed in the same boot mode.</p> <p>If the operating system supports UEFI, you can set this option to UEFI. Setting this field to BIOS allows compatibility with non-UEFI operating systems. This option is set to BIOS by default.</p> <p> NOTE: Setting this field to UEFI disables the BIOS Boot Settings menu. Setting this field to BIOS disables the UEFI Boot Settings menu.</p>
Boot Sequence Retry	Enables or disables the Boot Sequence Retry feature. If this option is set to Enabled and the 系統 fails to boot, the 系統 reattempts the boot sequence after 30 seconds. This option is set to Enabled by default.
Hard-Disk Failover	Specifies the hard drive that is booted in the event of a hard drive failure. The devices are selected in the Hard-Disk Drive Sequence on the Boot Option Setting menu. When this option is set to Disabled , only the first hard drive in the list is attempted to boot. When this option is set to Enabled , all hard drives are attempted to boot in the order selected in the Hard-Disk Drive Sequence . This option is not enabled for UEFI Boot Mode.
Boot Option Settings	Configures the boot sequence and the boot devices.
BIOS Boot Settings	<p>Enables or disables BIOS boot options.</p> <p> NOTE: This option is enabled only if the boot mode is BIOS.</p>
UEFI Boot Settings	<p>Enables or disables UEFI Boot options. The Boot options include IPv4 PXE and IPv6 PXE. This option is set to IPv4 by default.</p> <p> NOTE: This option is enabled only if the boot mode is UEFI.</p>

Network Settings screen details

The **Network Settings** screen details are explained as follows:

Option	Description
PXE Device n (n = 1 to 4)	Enables or disables the device. When enabled, a UEFI boot option is created for the device.
PXE Device n Settings (n = 1 to 4)	Enables you to control the configuration of the PXE device.

UEFI 設定畫面詳細資訊

您可以使用 iSCSI 設定畫面來修改 iSCSI 裝置設定。iSCSI 設定選項僅適用於在 UEFI 啟動模式。BIOS 無法控制 BIOS Boot Mode (啟動模式) 的網路設定。針對 BIOS 開機模式，網路控制器的 ROM 選項處理網路設定。



若要檢視 UEFI iSCSI 設定畫面，按一下 **System Setup Main Menu** (系統設定主選單) > 的系統 BIOS > 網路設定 > UEFI iSCSI 設定。

以下說明 **UEFI iSCSI Settings** (UEFI iSCSI 設定) 畫面的詳細資訊：

選項	說明
iSCSI Initiator 名稱	指定的 iSCSI Initiator 名稱 (iqn 格式)。
iSCSI 裝置 n (n=1 至 4)	啟用或停用 iSCSI 裝置。停用時，iSCSI 裝置的 UEFI 開機選項會自動建立。

Integrated Devices details

The **Integrated Devices** screen details are explained as follows:

Option	Description
User Accessible USB Ports	Enables or disables the USB ports. Selecting Only Back Ports On disables the front USB ports, selecting All Ports Off disables all USB ports. The USB keyboard and mouse operate during boot process in certain operating systems. After the boot process is complete, the USB keyboard and mouse do not work if the ports are disabled.  NOTE: Selecting Only Back Ports On and All Ports Off disables the USB management port and also restricts access to iDRAC features.
Internal USB Port	Enables or disables the internal USB port. This option is set to Enabled by default.
Integrated Network Card 1	Enables or disables the integrated network card.
Embedded NIC1 and NIC2	 NOTE: The Embedded NIC1 and NIC2 options are only available on 系統 that do not have Integrated Network Card 1. Enables or disables the Embedded NIC1 and NIC2 options. If set to Disabled , the NIC may still be available for shared network access by the embedded management controller. The embedded NIC1 and NIC2 options are only available on 系統 that do not have Network Daughter Cards (NDCs). The Embedded NIC1 and NIC2 option is mutually exclusive with the Integrated Network Card 1 option. Configure the Embedded NIC1 and NIC2 option by using the NIC management utilities of the 系統.

Option	Description
I/O Snoop Holdoff Response	Selects the number of cycles PCI I/O can withhold snoop requests from the CPU, to allow time to complete its own write to LLC. This setting can help improve performance on workloads where throughput and latency are critical.
Embedded Video Controller	Enables or disables the Embedded Video Controller option. This option is set to Enabled by default.
Current State of Embedded Video Controller	Displays the current state of the embedded video controller. The Current State of Embedded Video Controller option is a read-only field. If the Embedded Video Controller is the only display capability in the 系統 (that is, no add-in graphics card is installed), then the Embedded Video Controller is automatically used as the primary display even if the Embedded Video Controller setting is set to Disabled .
OS Watchdog Timer	If your 系統 stops responding, this watchdog timer aids in the recovery of your operating system. When this option is set to Enabled , the operating system initializes the timer. When this option is set to Disabled (the default), the timer does not have any effect on the 系統.
Memory Mapped I/O above 4 GB	Enables or disables the support for PCIe devices that need large amounts of memory. This option is set to Enabled by default.
Slot Disablement	Enables or disables the available PCIe slots on your 系統. The slot disablement feature controls the configuration of PCIe cards installed in the specified slot. Slots must be disabled only when the installed peripheral card prevents booting into the operating system or causes delays in 系統 startup. If the slot is disabled, both the Option ROM and UEFI drivers are disabled.

Serial Communication details

The **Serial Communication** screen details are explained as follows:

Option	Description
Serial Communication	Selects serial communication devices (Serial Device 1 and Serial Device 2) in BIOS. BIOS console redirection can also be enabled and the port address can be specified. This option is set to Auto by default.
Serial Port Address	Enables you to set the port address for serial devices. This option is set to Serial Device 1=COM2, Serial Device 2=COM1 by default. <ul style="list-style-type: none"> NOTE: You can use only Serial Device 2 for the Serial Over LAN (SOL) feature. To use console redirection by SOL, configure the same port address for console redirection and the serial device. NOTE: Every time the 系統 boots, the BIOS syncs the serial MUX setting saved in iDRAC. The serial MUX setting can independently be changed in iDRAC. Loading the BIOS default settings from within the BIOS setup utility may not always revert the serial MUX setting to the default setting of Serial Device 1.
External Serial Connector	Enables you to associate the External Serial Connector to Serial Device 1, Serial Device 2, or the Remote Access Device by using this option. <ul style="list-style-type: none"> NOTE: Only Serial Device 2 can be used for Serial Over LAN (SOL). To use console redirection by SOL, configure the same port address for console redirection and the serial device. NOTE: Every time the 系統 boots, the BIOS syncs the serial MUX setting saved in iDRAC. The serial MUX setting can independently be changed in iDRAC. Loading the BIOS default settings from within the BIOS setup utility may not always revert this setting to the default setting of Serial Device 1.
Failsafe Baud Rate	Specifies the failsafe baud rate for console redirection. The BIOS attempts to determine the baud rate automatically. This failsafe baud rate is used only if the attempt fails, and the value must not be changed. This option is set to 115200 by default.
Remote Terminal Type	Sets the remote console terminal type. This option is set to VT 100/VT 220 by default.

Option	Description
Redirection After Boot	Enables or disables the BIOS console redirection when the operating system is loaded. This option is set to Enabled by default.



System Profile Settings details

The **System Profile Settings** screen details are explained as follows:

Option	Description
System Profile	<p>Sets the system profile. If you set the System Profile option to a mode other than Custom, the BIOS automatically sets the rest of the options. You can only change the rest of the options if the mode is set to Custom. This option is set to Performance Per Watt (OS).</p> <p>NOTE: All the parameters on the system profile setting screen are available only when the System Profile option is set to Custom.</p>
CPU Power Management	Sets the CPU power management. This option is set to OS DBPM by default.
Memory Frequency	Sets the speed of the memory. You can select Maximum Performance , Maximum Reliability , or a specific speed.
Turbo Boost	Enables or disables the processor to operate in the turbo boost mode. This option is set to Enabled by default.
C1E	Enables or disables the processor to switch to a minimum performance state when it is idle. This option is set to Enabled by default.
C States	Enables or disables the processor to operate in all available power states. This option is set to Enabled by default.
Memory Refresh Rate	Sets the memory refresh rate to either 1x or 2x. This option is set to 1x by default.
Uncore Frequency	<p>Enables you to select the Processor Uncore Frequency option.</p> <p>Dynamic mode enables the processor to optimize power resources across the cores and uncore during runtime. The optimization of the uncore frequency to either save power or optimize performance is influenced by the setting of the Energy Efficiency Policy option.</p>
Energy Efficient Policy	<p>Enables you to select the Energy Efficient Policy option.</p> <p>The CPU uses the setting to manipulate the internal behavior of the processor and determines whether to target higher performance or better power savings.</p>
Number of Turbo Boot Enabled Cores for Processor 1	Controls the number of turbo boost enabled cores for processor 1. The maximum number of cores is enabled by default.
Monitor/Mwait	<p>Enables the Monitor/Mwait instructions in the processor. This option is set to Enabled for all 系統 profiles, except Custom by default.</p> <p>NOTE: This option can be disabled only if the C States option in the Custom mode is set to disabled.</p> <p>NOTE: When C States is set to Enabled in the Custom mode, changing the Monitor/Mwait setting does not impact the 系統 power or performance.</p>

System Security Settings details

The **System Security Settings** screen details are explained as follows:

Option	Description
Intel AES-NI	Improves the speed of applications by performing encryption and decryption by using the Advanced Encryption Standard Instruction Set (AES-NI). This option is set to Enabled by default.
System Password	Sets the 系統 password. This option is set to Enabled by default and is read-only if the password jumper is not installed in the 系統.
Setup Password	Sets the setup password. This option is read-only if the password jumper is not installed in the 系統.
Password Status	Locks the 系統 password. This option is set to Unlocked by default.
TPM Security	<p> NOTE: The TPM menu is available only when the TPM module is installed.</p> <p>Enables you to control the reporting mode of the TPM. The TPM Security option is set to Off by default. You can only modify the TPM Status, TPM Activation, and Intel TXT fields if the TPM Status field is set to either On with Pre-boot Measurements or On without Pre-boot Measurements.</p>
TPM Information	Changes the operational state of the TPM. This option is set to No Change by default.
TPM Status	Specifies the TPM status.
TPM Command	<p> CAUTION: Clearing the TPM results in the loss of all keys in the TPM. The loss of TPM keys may affect booting to the operating system.</p> <p>Clears all the contents of the TPM. The TPM Clear option is set to No by default.</p>
Intel TXT	Enables or disables the Intel Trusted Execution Technology (TXT) option. To enable the Intel TXT option, virtualization technology and TPM Security must be enabled with Pre-boot measurements. This option is set to Off by default.
Power Button	Enables or disables the power button on the front of the 系統. This option is set to Enabled by default.
NMI Button	Enables or disables the NMI button on the front of the 系統. This option is set to Disabled by default.
AC Power Recovery	Sets how the 系統 behaves after AC power is restored to the 系統. This option is set to Last by default.
AC Power Recovery Delay	Sets the time delay for the 系統 to power up after AC power is restored to the 系統. This option is set to Immediate by default.
User Defined Delay (60s to 240s)	Sets the User Defined Delay option when the User Defined option for AC Power Recovery Delay is selected.
UEFI Variable Access	Provides varying degrees of securing UEFI variables. When set to Standard (the default), UEFI variables are accessible in the operating system per the UEFI specification. When set to Controlled , selected UEFI variables are protected in the environment and new UEFI boot entries are forced to be at the end of the current boot order.
Secure Boot Policy	When Secure Boot policy is set to Standard , the BIOS uses the 系統 manufacturer's key and certificates to authenticate pre-boot images. When Secure Boot policy is set to Custom , the BIOS uses the user-defined key and certificates. Secure Boot policy is set to Standard by default.
Secure Boot Policy Summary	Specifies the list of certificates and hashes that secure boot uses to authenticate images.

Secure Boot (安全啟動) 自訂原則設定畫面的詳細資訊

當 **Secure Boot Policy (安全啟動原則)** 設為 **Custom (自訂)** 時，會顯示 **Secure Boot Custom Policy Settings (安全啟動自訂政策設定)**。

要檢視安全啟動自訂政策設定畫面，按一下 **System Setup Main Menu (系統設定主選單)** > 的 **系統 BIOS** > 的 **系統安全性的** > **安全啟動自訂政策設定**。



以下說明 **Secure Boot Custom Policy Settings (安全啟動自訂原則設定)** 畫面的詳細資訊：

選項	說明
Platform Key	匯入、匯出、刪除或還原平台金鑰 (PK)。

選項	說明
Key Exchange Key Database	可讓您匯入、匯出、刪除或還原金鑰交換金鑰 (KEK) 資料庫中的項目。
Authorized Signature Database	匯入、匯出、刪除或還原 Authorized Signature Database (授權簽章資料庫) (db) 中的項目。
Forbidden Signature Database	匯入、匯出、刪除或還原 Forbidden Signature Database (禁止簽章資料庫) (db) 中的項目。

Miscellaneous Settings details

The **Miscellaneous Settings** screen details are explained as follows:

Option	Description
System Time	Enables you to set the time on the 系統.
System Date	Enables you to set the date on the 系統.
Asset Tag	Specifies the asset tag and enables you to modify it for security and tracking purposes.
Keyboard NumLock	Enables you to set whether the 系統 boots with the NumLock enabled or disabled. This option is set to On by default.  NOTE: This option does not apply to 84-key keyboards.
F1/F2 Prompt on Error	Enables or disables the F1/F2 prompt on error. This option is set to Enabled by default. The F1/F2 prompt also includes keyboard errors.
Load Legacy Video Option ROM	Enables you to determine whether the system BIOS loads the legacy video (INT 10H) option ROM from the video controller. Selecting Enabled in the operating system does not support UEFI video output standards. This field is available only for UEFI boot mode. You cannot set the option to Enabled if UEFI Secure Boot mode is enabled.
In-System Characterization	Enables or disables In-System Characterization . This option is set to Disabled by default. The two other options are Enabled and Enabled - No Reboot .  NOTE: The default setting for In-System Characterization is subject to change in future BIOS releases. When enabled, In-System Characterization (ISC) executes during POST upon detecting relevant changes in 系統 configuration to optimize 系統 power and performance. ISC takes about 20 seconds to execute, and 系統 reset is needed for ISC results to be applied. The Enabled - No Reboot option executes ISC and continues without applying ISC results until the next time 系統 reset occurs. The Enabled option executes ISC and forces an immediate 系統 reset so that ISC results can be applied. It takes the 系統 longer to be ready due to the forced 系統 reset. When disabled, ISC does not execute.

有關 Boot Manager

Boot Manager 可讓您新增、刪除和排列開機選項。您也可以使用系統設定和啟動選項而不重新啟動系統。

Viewing Boot Manager

To enter **Boot Manager**:

- 1 Turn on, or restart your 系統.
- 2 Press F11 when you see the following message:

```
F11 = Boot Manager
```

If your operating system begins to load before you press F11, allow the 系統 to complete the booting, and then restart your 系統 and try again.

Boot Manager main menu

Menu item	Description
Continue Normal Boot	The 系統 attempts to boot to devices starting with the first item in the boot order. If the boot attempt fails, the 系統 continues with the next item in the boot order until the boot is successful or no more boot options are found.
One-shot Boot Menu	Enables you to access boot menu, where you can select a one-time boot device to boot from.
Launch System Setup	Enables you to access System Setup.
Launch Lifecycle Controller	Exits the Boot Manager and invokes the Dell Lifecycle Controller program.
System Utilities	Enables you to launch System Utilities menu such as System Diagnostics and UEFI shell.

關於 Dell Lifecycle Controller

Dell Lifecycle Controller 可讓您執行一些工作，例如配置 BIOS 與硬體設定、部署作業系統、更新驅動程式，變更 RAID 設定、及儲存硬體設定檔。如需 Dell Lifecycle Controller 的更多資訊，請參閱 Dell.com/idracmanuals 上的說明文件。

Changing the boot order

About this task

You may have to change the boot order if you want to boot from a USB key or an optical drive. The following instructions may vary if you have selected **BIOS** for **Boot Mode**.

Steps

- 1 On the **System Setup Main Menu** screen, click **System BIOS > Boot Settings**.
- 2 Click **Boot Option Settings > Boot Sequence**.
- 3 Use the arrow keys to select a boot device, and use the plus (+) and minus (-) sign keys to move the device down or up in the order.
- 4 Click **Exit**, and then click **Yes** to save the settings on exit.

Choosing the 系統 boot mode

System Setup enables you to specify one of the following boot modes for installing your operating system:

- BIOS boot mode (the default) is the standard BIOS-level boot interface.
- Unified Extensible Firmware Interface (UEFI) (the default) boot mode is an enhanced 64-bit boot interface. If you have configured your 系統 to boot to UEFI mode, it replaces the system BIOS.

- 1 From the **System Setup Main Menu**, click **Boot Settings**, and select **Boot Mode**.
- 2 Select the boot mode you want the 系統 to boot into.

 **CAUTION: Switching the boot mode may prevent the 系統 from booting if the operating system is not installed in the same boot mode.**

- 3 After the 系統 boots in the specified boot mode, proceed to install your operating system from that mode.

NOTE:

- Operating systems must be UEFI-compatible to be installed from the UEFI boot mode. DOS and 32-bit operating systems do not support UEFI and can only be installed from the BIOS boot mode.
- For the latest information about supported operating systems, go to Dell.com/ossupport.

Creating a system or setup password

Prerequisites

Ensure that the password jumper setting is enabled. The password jumper enables or disables the system password and setup password features. For more information about the password jumper settings, see [主機板跳線和連接器](#)

Ensure that password status is unlocked in the **System Security Settings** screen. For more information, see [System Security Settings details](#)

 **NOTE: If the password jumper setting is disabled, the existing system password and setup password are deleted and you need not provide the system password to boot the system.**

Steps

- 1 To enter system setup, press F2 immediately after turning on or restarting the system.
- 2 On the **System Setup Main Menu** screen, click **System BIOS > System Security**.
- 3 On the **System Security** screen, verify that **Password Status** is set to **Unlocked**.
- 4 In the **System Password** field, type your system password, and then press Enter or Tab.

Use the following guidelines to assign the system password:

- A password can have up to 32 characters.
- The password can contain the numbers 0 through 9.
- Only the following special characters are allowed: space, ("), (+), (,), (-), (.), (/), (:), ([), (\), (]), (^).

A message prompts you to reenter the system password.

- 5 Reenter the system password, and click **OK**.
- 6 In the **Setup Password** field, type your system password, and then press Enter or Tab.
A message prompts you to reenter the setup password.
- 7 Reenter the setup password, and click **OK**.
- 8 Press Esc to return to the **System BIOS** screen. Press Esc again.
A message prompts you to save the changes.

 **NOTE: Password protection does not take effect until the system reboots.**

Using your 系統 password to secure your 系統

About this task

If you have assigned a setup password, the 系統 accepts your setup password as an alternate 系統 password.

Steps

- 1 Turn on or reboot your 系統.
- 2 Type the 系統 password and press Enter.

Next step

When **Password Status** is set to **Locked**, type the 系統 password and press Enter when prompted at reboot.

NOTE: If an incorrect 系統 password is typed, the 系統 displays a message and prompts you to reenter your password. You have three attempts to type the correct password. After the third unsuccessful attempt, the 系統 displays an error message that the 系統 has stopped functioning and must be turned off. Even after you turn off and restart the 系統, the error message is displayed until the correct password is entered.

Deleting or changing 系統 and setup password

Prerequisite

NOTE: You cannot delete or change an existing 系統 or setup password if the **Password Status** is set to **Locked**.

Steps

- 1 To enter System Setup, press F2 immediately after turning on or restarting your 系統.
- 2 On the **System Setup Main Menu** screen, click **System BIOS > System Security**.
- 3 On the **System Security** screen, ensure that **Password Status** is set to **Unlocked**.
- 4 In the **System Password** field, alter or delete the existing 系統 password, and then press Enter or Tab.
- 5 In the **Setup Password** field, alter or delete the existing setup password, and then press Enter or Tab.
If you change the 系統 and setup password, a message prompts you to reenter the new password. If you delete the 系統 and setup password, a message prompts you to confirm the deletion.
- 6 Press Esc to return to the **System BIOS** screen. Press Esc again, and a message prompts you to save the changes.

Operating with a setup password enabled

If **Setup Password** is set to **Enabled**, type the correct setup password before modifying the 系統 setup options.

If you do not type the correct password in three attempts, the 系統 displays the following message:

```
Invalid Password! Number of unsuccessful password attempts: <x> System Halted! Must power down.
```

Even after you turn off and restart the 系統, the error message is displayed until the correct password is typed. The following options are exceptions:

- If **System Password** is not set to **Enabled** and is not locked through the **Password Status** option, you can assign a 系統 password. For more information, see the System Security Settings screen section.
- You cannot disable or change an existing 系統 password.

NOTE: You can use the password status option with the setup password option to protect the 系統 password from unauthorized changes.

Embedded systems management

The Dell Lifecycle Controller provides advanced embedded systems management throughout the lifecycle of the 系統. The Dell Lifecycle Controller can be started during the boot sequence and can function independently of the operating system.

① | **NOTE: Certain platform configurations may not support the full set of features provided by the Dell Lifecycle Controller.**

For more information about setting up the Dell Lifecycle Controller, configuring hardware and firmware, and deploying the operating system, see the Dell Lifecycle Controller documentation at Dell.com/idracmanuals.

iDRAC Settings utility

The iDRAC settings utility is an interface to set up and configure the iDRAC parameters by using UEFI. You can enable or disable various iDRAC parameters by using the iDRAC settings utility.

① | **NOTE: Accessing some of the features on the iDRAC settings utility needs the iDRAC Enterprise License upgrade.**

For more information about using iDRAC, see *Dell Integrated Dell Remote Access Controller User's Guide* at Dell.com/idracmanuals.

Entering the iDRAC Settings utility

- 1 Turn on or restart the managed 系統.
- 2 Press F2 during Power-on Self-test (POST).
- 3 On the **System Setup Main Menu** page, click **iDRAC Settings**.
The **iDRAC Settings** screen is displayed.

Changing the thermal settings

The iDRAC settings utility enables you to select and customize the thermal control settings for your 系統.

- 1 Click **iDRAC Settings > Thermal**.
- 2 Under **SYSTEM THERMAL PROFILE > Thermal Profile**, select one of the following options:
 - Default Thermal Profile Settings
 - Maximum Performance (Performance Optimized)
 - Minimum Power (Performance per Watt Optimized)
- 3 Under **USER COOLING OPTIONS**, set the **Fan Speed Offset**, **Minimum Fan Speed**, and **Custom Minimum Fan Speed**.
- 4 Click **Back > Finish > Yes**.

安裝和卸下系統元件

Safety instructions

⚠ **WARNING:** 需要抬起系統時，請尋求他人協助。為避免受傷，請勿嘗試靠自己一人抬起系統。

⚠ **WARNING:** Opening or removing the 系統 cover while the 系統 is powered on may expose you to a risk of electric shock.

⚠ **CAUTION:** Do not operate the 系統 without the cover for a duration exceeding five minutes.

⚠ **CAUTION:** 許多維修僅可由獲得認可的維修技術人員來完成。您只能依照產品說明文件中的授權說明或在線上或電話服務和支援團隊的指導下，執行故障排除和簡單的維修。由未經 Dell 授權的維修造成的損壞不在保固範圍之內。請閱讀並遵循產品隨附的安全說明。

① **NOTE:** 建議在操作系統內的元件時，隨時使用抗靜電墊和抗靜電手環。

① **NOTE:** To ensure proper operation and cooling, all bays in the 系統 and 系統 fans must be populated always with either a component or with a blank.

拆裝系統內部元件之前

事前準備作業

請確定您遵循 [Safety instructions](#)。

步驟

- 1 關閉系統及任何連接的周邊裝置。
- 2 從電源插座拔下系統電源線，並拔下周邊裝置。
- 3 將系統側面朝下放好。
- 4 卸下系統機箱蓋。

相關連結

[Removing the system cover](#)

拆裝系統內部元件之後

- 1 安裝系統機箱蓋。
- 2 讓系統底部朝下，直立於平坦且穩固的平面上。
- 3 重新連接周邊裝置並將系統連接至電源插座。
- 4 關閉系統，包括任何已連接的周邊裝置。

相關連結

[Installing the system cover](#)

建議的工具

您需要下列工具來進行卸下和安裝程序：

- Phillips 2 號螺絲起子

- 塑膠劃線器
- 將接地腕帶接地

System cover

The system cover protects the components inside the system and helps in maintaining air flow inside the system. Removing the system cover activates the intrusion switch.

Removing the system cover

Prerequisites

- 1 Ensure that you follow the [Safety instructions](#).
- 2 Turn off the system and any attached peripherals.
- 3 Disconnect the system from the electrical outlet and disconnect the peripherals.
- 4 Lay the system on its side.

Step

Lift the cover release latch and remove the cover away from the system.

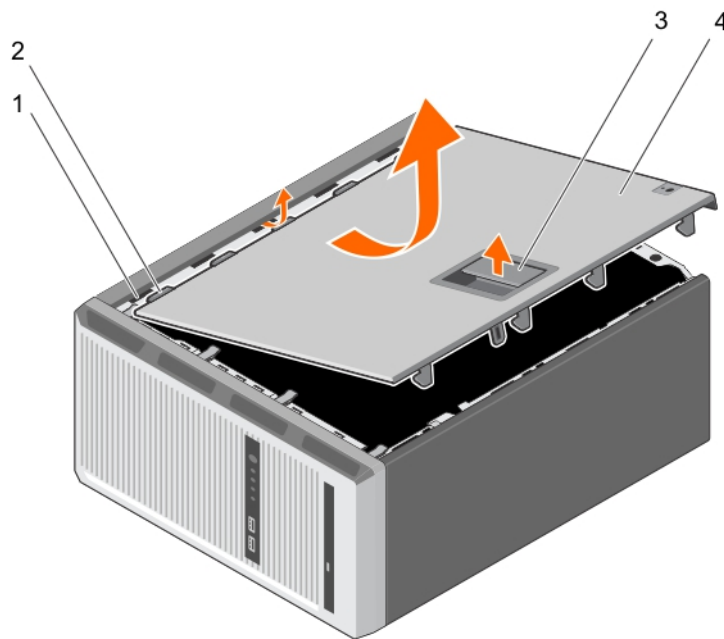

Figure 8. Removing the system cover

- | | | | |
|---|---------------------|---|--------------|
| 1 | slots | 2 | tabs |
| 3 | cover release latch | 4 | system cover |

Next steps

- 1 Install the system cover.
- 2 Place the system upright on its feet on a flat and stable surface.
- 3 Reconnect the peripherals and connect the system to the electrical outlet.
- 4 Turn the system on, including any attached peripherals.

Related links

[Installing the system cover](#)

Installing the system cover

Prerequisites

- 1 Ensure that you follow the [Safety instructions](#).
- 2 Follow the procedure listed in [拆裝系統內部元件之前](#).
- 3 Ensure that all internal cables are connected and placed out of the way and that no tools or extra parts are left inside the system.

Steps

- 1 Align the tabs on the system cover with the corresponding slots on the system chassis.
- 2 Lower the system cover onto the chassis until it clicks into place.

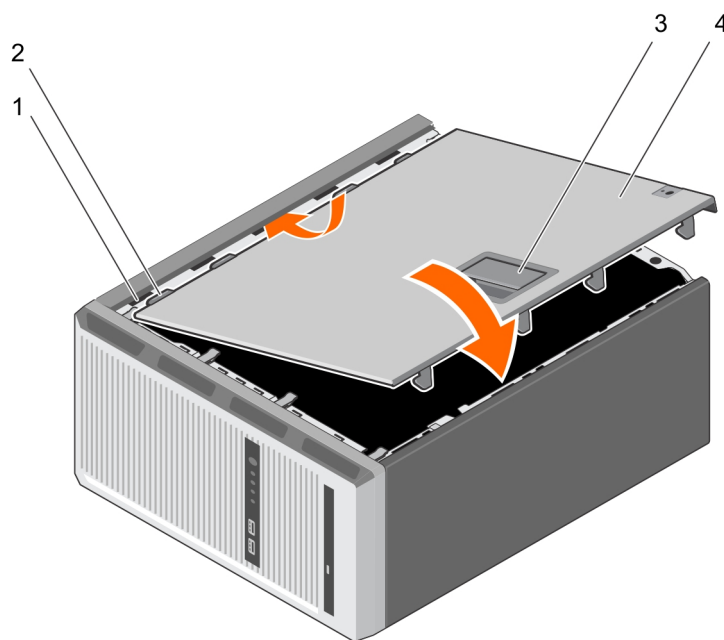

Figure 9. Installing the system cover

- | | |
|-----------------------|----------------|
| 1 slots | 2 tabs |
| 3 cover release latch | 4 system cover |

Next steps

- 1 Place the system upright on its feet on a flat and stable surface.
- 2 Reconnect the peripherals and connect the system to the electrical outlet
- 3 Turn the system on, including any attached peripherals.

前蓋

將前蓋連接至伺服器前側，並防止卸下硬碟或按下重設或電源按鈕時發生事故。也可以鎖定前蓋以提高高安全性。

Removing the bezel

Prerequisites

- 1 Ensure that you follow the [Safety instructions](#).
- 2 Follow the procedure listed in [拆裝系統內部元件之前](#).

Steps

- 1 Lift the retention clips at the edge of the bezel.
- 2 Lift the bezel and pull it away from the system.

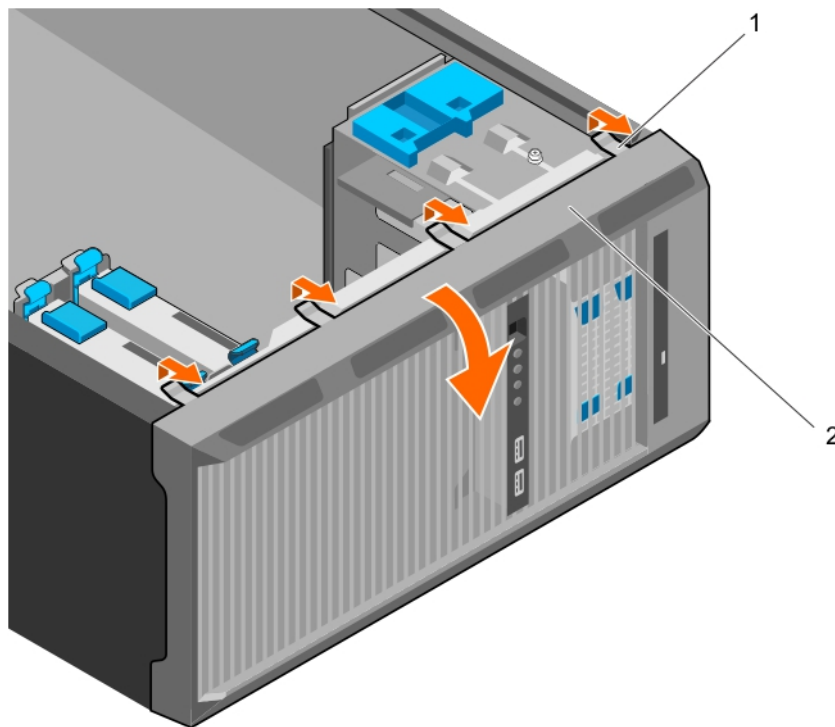

Figure 10. Removing the bezel

1 retention clips (4)

2 bezel

Next steps

- 1 Install the bezel.
- 2 Follow the procedure listed in [拆裝系統內部元件之後](#).

Related links

[Installing the bezel](#)

Installing the bezel

Prerequisites

- 1 Ensure that you follow the [Safety instructions](#).
- 2 Follow the procedure listed in [拆裝系統內部元件之前](#).

Steps

- 1 Insert the bezel tabs into the bezel tab slots on the chassis.
- 2 Press the bezel into the chassis until the retention clips lock into place.

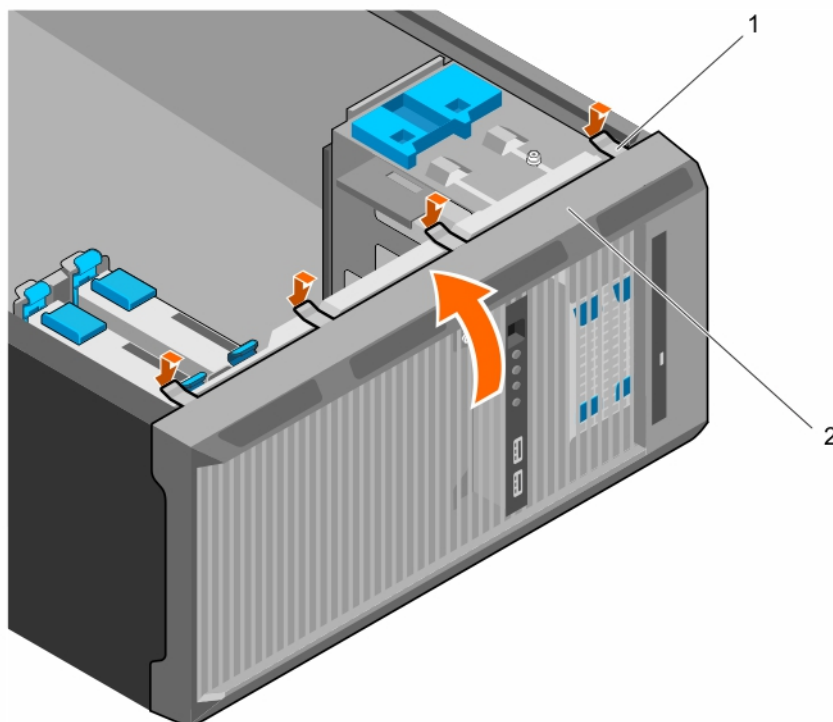

Figure 11. Installing the bezel

1 retention clips (4)

2 bezel

Next step

- 1 Follow the procedure listed in [拆裝系統內部元件之後](#).

系統內部



圖 12. 系統內部

- | | | | |
|---|-----------|---|-------------|
| 1 | 硬碟 | 2 | 處理器 |
| 3 | 擴充卡固定門鎖 | 4 | PCIe 插槽 (4) |
| 5 | 系統風扇 | 6 | 電源供應器 |
| 7 | 記憶體插槽 (4) | 8 | 硬碟固定框架 |
| 9 | 硬碟固定框架門鎖 | | |

侵入切換開關

Removing the intrusion switch

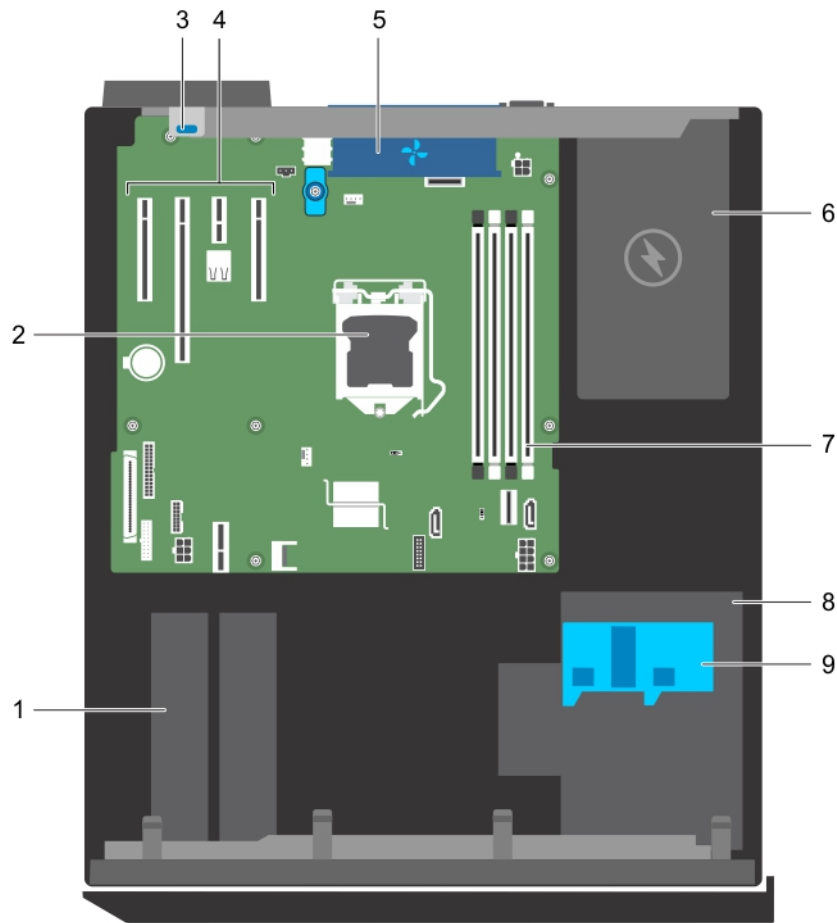
Prerequisites

△ CAUTION: 許多維修僅可由獲得認可的維修技術人員來完成。您只能依照產品說明文件中的授權說明或在線上或電話服務和支援團隊的指導下，執行故障排除和簡單的維修。由未經 Dell 授權的維修造成的損壞不在保固範圍之內。請閱讀並遵循產品隨附的安全說明。

- 1 Ensure that you follow the [Safety instructions](#).
- 2 Follow the procedure listed in [拆裝系統內部元件之前](#).

Steps

- 1 Disconnect the intrusion switch cable from the system board.
- 2 Slide the intrusion switch and push it out of the slot on the chassis.

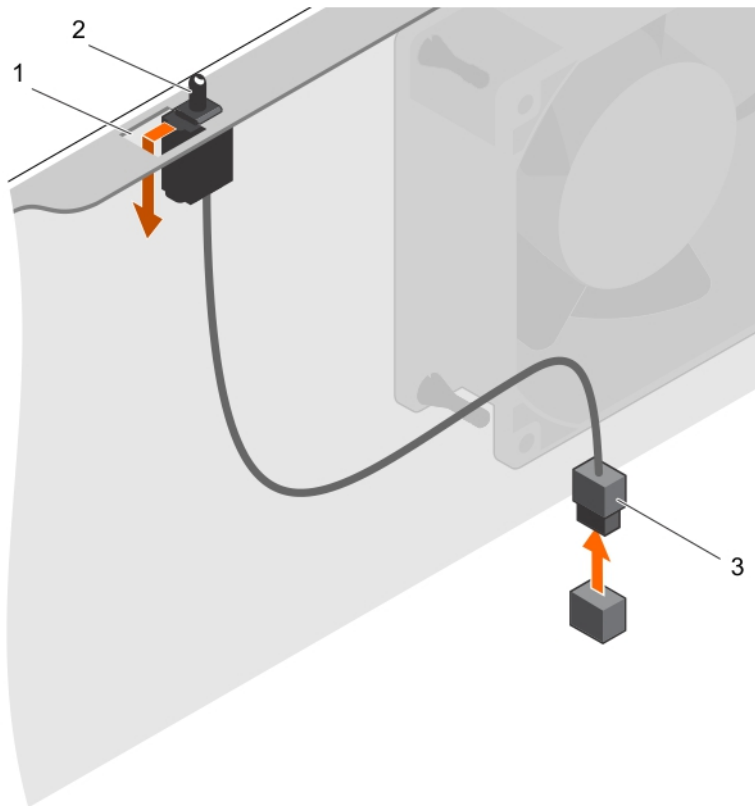

Figure 13. Removing the intrusion switch

- | | | | |
|---|------------------------|---|------------------|
| 1 | intrusion switch slot | 2 | intrusion switch |
| 3 | intrusion switch cable | | |

Next steps

- 1 Install the intrusion switch.
- 2 Follow the procedure listed in [拆裝系統內部元件之後](#).

Related links

[Installing the intrusion switch](#)

Installing the intrusion switch

Prerequisites

△ CAUTION: 許多維修僅可由獲得認可的維修技術人員來完成。您只能依照產品說明文件中的授權說明或在線上或電話服務和支援團隊的指導下，執行故障排除和簡單的維修。由未經 **Dell** 授權的維修造成的損壞不在保固範圍之內。請閱讀並遵循產品隨附的安全說明。

- 1 Ensure that you follow the [Safety instructions](#).

- 2 Follow the procedure listed in [拆裝系統內部元件之前](#).

Steps

- 1 To install the intrusion switch, insert the intrusion switch into the intrusion switch slot and slide the switch into place.
- 2 Connect the intrusion switch cable to the system board.

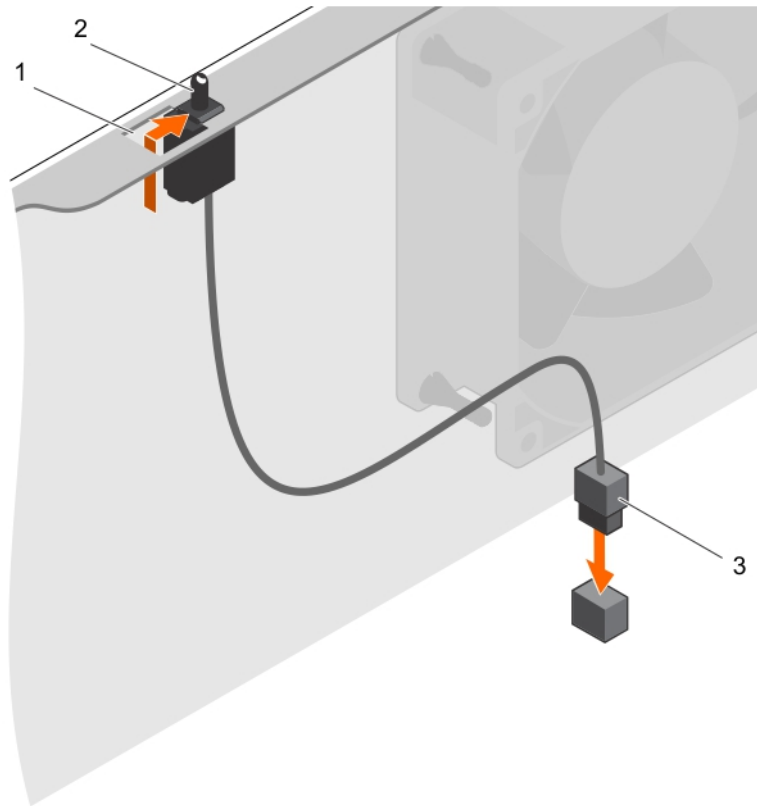

Figure 14. Installing the intrusion switch

- | | |
|--------------------------|--------------------|
| 1 intrusion switch slot | 2 intrusion switch |
| 3 intrusion switch cable | |

Next step

Follow the procedure listed in [拆裝系統內部元件之後](#).

Control panel

The control panel contains the power button, the diagnostic indicators, and the front USB ports.

Removing the control panel assembly

Prerequisites

CAUTION: 許多維修僅可由獲得認可的維修技術人員來完成。您只能依照產品說明文件中的授權說明或在線上或電話服務和支援團隊的指導下，執行故障排除和簡單的維修。由未經 **Dell** 授權的維修造成的損壞不在保固範圍之內。請閱讀並遵循產品隨附的安全說明。

- 1 Ensure that you follow the [Safety instructions](#).
- 2 Follow the procedure listed in [拆裝系統內部元件之前](#).

- 3 Disconnect all peripherals connected to the control panel assembly.
- 4 Remove the bezel.
- 5 Keep the Phillips #2 screwdriver ready.

Steps

- 1 Disconnect the control panel and USB data cables from the system board.
- 2 Remove the screws securing the control panel assembly to the system.
- 3 Slide the control panel assembly upward to release it.
- 4 Pull the control panel assembly along with the cables out of the system.

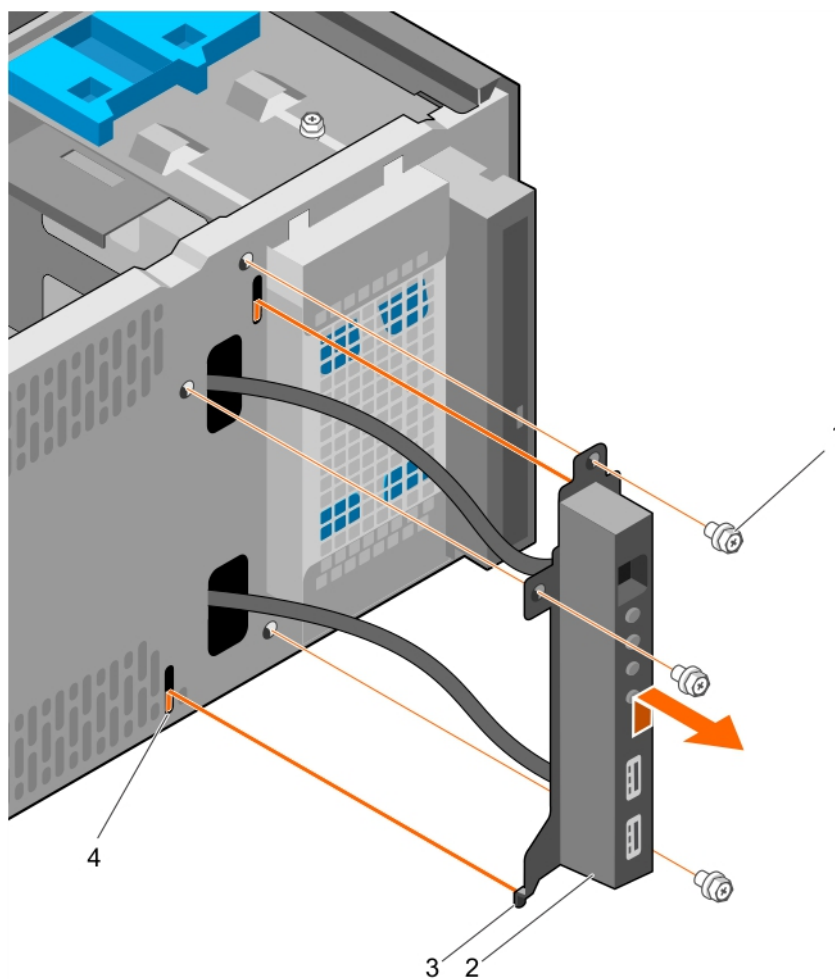

Figure 15. Removing the control panel assembly

- | | | | |
|---|----------------------------------|---|---------------------------------------|
| 1 | screw (3) | 2 | control panel assembly |
| 3 | control panel assembly guide (2) | 4 | control panel assembly guide slot (2) |

Next steps

- 1 Install the control panel assembly.
- 2 Install the bezel.
- 3 Follow the procedure listed in [拆裝系統內部元件之後](#).

Related links

- [Removing the bezel](#)
- [Installing the control panel assembly](#)
- [Installing the bezel](#)

Installing the control panel assembly

Prerequisites

CAUTION: 許多維修僅可由獲得認可的維修技術人員來完成。您只能依照產品說明文件中的授權說明或在線上或電話服務和支援團隊的指導下，執行故障排除和簡單的維修。由未經 Dell 授權的維修造成的損壞不在保固範圍之內。請閱讀並遵循產品隨附的安全說明。

- 1 Ensure that you follow the [Safety instructions](#).
- 2 Follow the procedure listed in [拆裝系統內部元件之前](#).
- 3 Remove the bezel.
- 4 Keep the Phillips #2 screwdriver ready.

Steps

- 1 Insert the control panel assembly into the guide slot and slide it downward to lock the assembly into place.
- 2 To secure the control panel, insert and tighten the screws to the chassis.
- 3 Route the control panel and USB data cables through the chassis clip.
- 4 Connect the control panel and USB data cables to the system board.

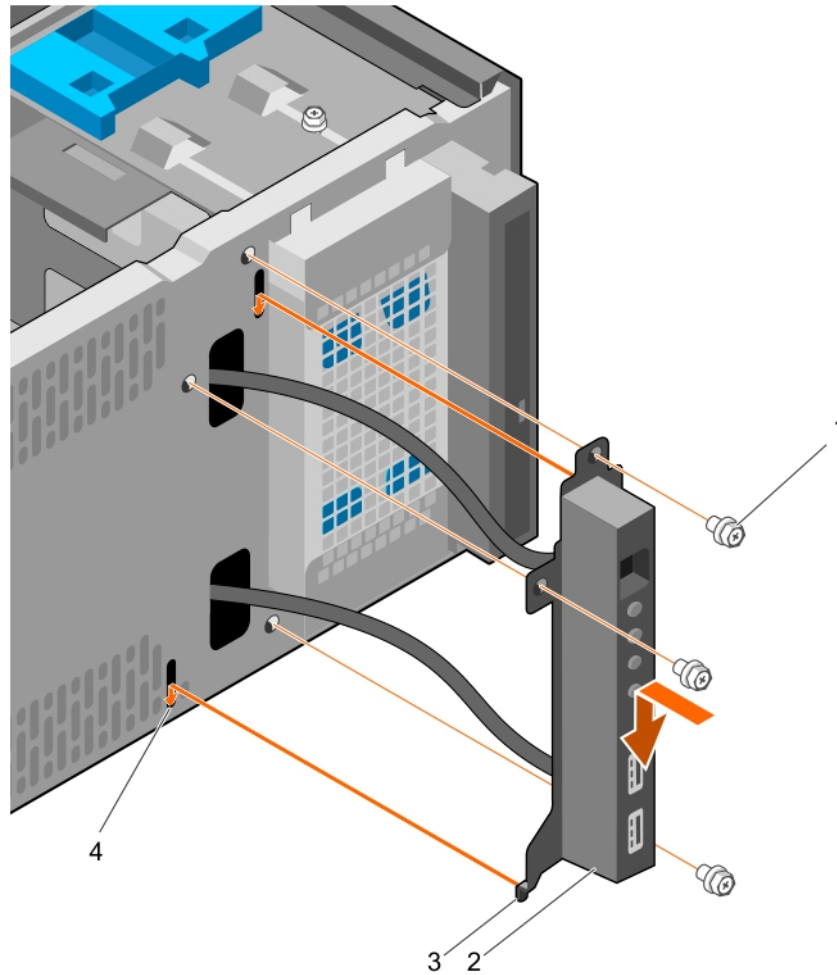

Figure 16. Installing the control panel assembly

1 screw (3)

2 control panel assembly

Next steps

- 1 Install the bezel.
- 2 Reconnect the disconnected peripherals from the control panel assembly.
- 3 Follow the procedure listed in [拆裝系統內部元件之後](#).

Related links

- [Removing the bezel](#)
- [Installing the bezel](#)

硬碟

△ 警告: 當硬碟正在格式化時，請勿關閉或重新啟動系統。否則可能會導致硬碟故障。

ⓘ 註: 請勿混用企業級硬碟和入門型硬碟。

您的系統支援四個 3.5 英寸的入門級硬碟和企業級硬碟。入門硬碟的設計目的是為了 8X5 作業環境，而企業級的硬碟是專為 24X7 的作業環境。二個硬碟位於可拆卸式硬碟固定框架，而二個硬碟位於固定硬碟的凹槽中。

依據使用模式選擇正確類型的硬碟。不當使用入門硬碟（工作負載等級超過 55TB / 年）會導致明顯風險，並增加磁碟機故障率。由於產業進步，在某些情況下，較大容量磁碟機已變更到較大的磁區大小。較大磁區大小會影響作業系統和應用程式。如需更多關於這些硬碟的資訊，請參閱 *512e* 和 *4Kn* 磁碟格式白皮書和 *4K 區 HDD 常見問題集文件*，位於 Dell.com/poweredgemanuals。

所有硬碟均透過硬碟背板連接至主機板，硬碟承載器附在裝在硬碟插槽中的熱插拔硬碟托架中。

當您格式化硬碟時，請保留足夠的時間讓格式化作業完成。請注意，大容量硬碟可能需要花費數小時的時間完成格式化。

Removing the hard drive cage

Prerequisites

△ CAUTION: 許多維修僅可由獲得認可的維修技術人員來完成。您只能依照產品說明文件中的授權說明或在線上或電話服務和支援團隊的指導下，執行故障排除和簡單的維修。由未經 Dell 授權的維修造成的損壞不在保固範圍之內。請閱讀並遵循產品隨附的安全說明。

- 1 Ensure that you follow the [Safety instructions](#).
- 2 Follow the procedure listed in [拆裝系統內部元件之前](#).
- 3 Disconnect all peripherals connected to the control panel assembly.
- 4 Remove the bezel.
- 5 If connected, disconnect the power and data cables from the hard drives and the optical drive in the hard drive cage.

Step

Slide and hold the hard drive cage latch and pull the hard drive cage out of the system.

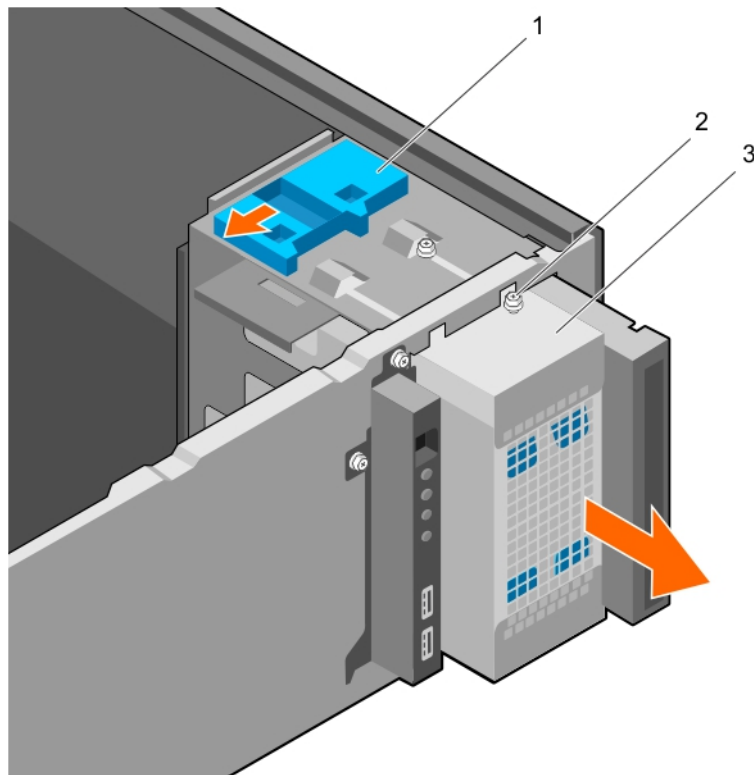

Figure 17. Removing the hard drive cage

- | | | | |
|---|-----------------------|---|---------------------------------|
| 1 | hard drive cage latch | 2 | hard drive cage guide screw (2) |
| 3 | hard drive cage | | |

Next steps

- 1 Install the hard drive cage.
- 2 If disconnected, connect the power and data cables to the hard drives and the optical drive in the hard drive cage.
- 3 Install the bezel.
- 4 Reconnect the peripherals disconnected from the control panel assembly.
- 5 Follow the procedure listed in [拆裝系統內部元件之後](#).

Related links

- [Removing the bezel](#)
- [Installing the hard drive cage](#)
- [Installing the bezel](#)

Installing the hard drive cage

Prerequisites

- 1 Ensure that you follow the [Safety instructions](#).
- 2 Follow the procedure listed in [拆裝系統內部元件之前](#).
- 3 Disconnect all peripherals connected to the control panel assembly.
- 4 Remove the bezel.

CAUTION: 許多維修僅可由獲得認可的維修技術人員來完成。您只能依照產品說明文件中的授權說明或在線上或電話服務和支援團隊的指導下，執行故障排除和簡單的維修。由未經 Dell 授權的維修造成的損壞不在保固範圍之內。請閱讀並遵循產品隨附的安全說明。

Step

Insert the hard drive cage into the system until it clicks into place.

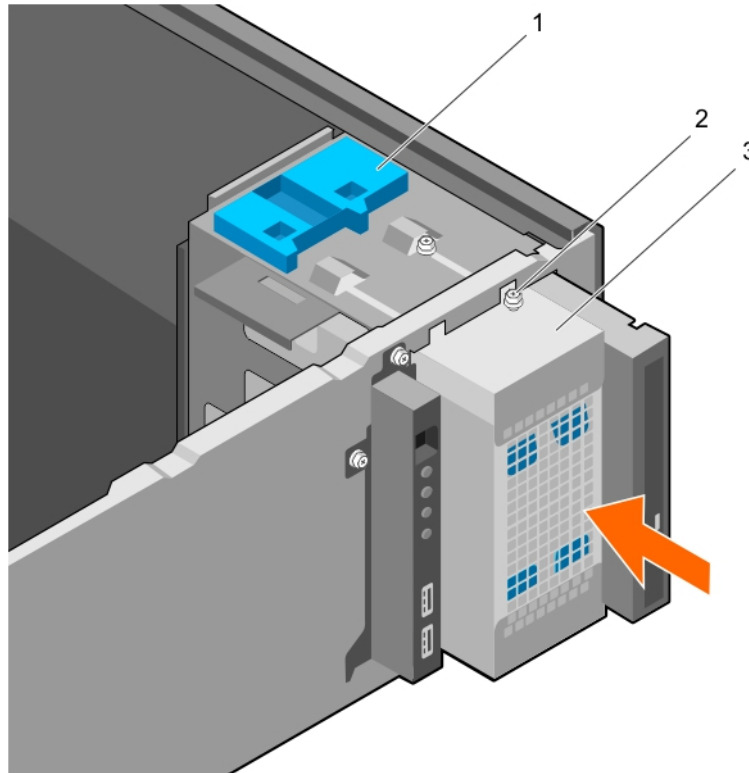

Figure 18. Installing the hard drive cage

- 1 hard drive cage latch
- 2 hard drive cage guide screw (2)
- 3 hard drive cage

Next steps

- 1 If disconnected, reconnect the power and data cables to the hard drives and optical drive in the hard drive cage.
- 2 Install the bezel.
- 3 Reconnect the peripherals disconnected from the control panel assembly.
- 4 Follow the procedure listed in [拆裝系統內部元件之後](#).

Related links

- [Removing the bezel](#)
- [Installing the bezel](#)

Removing a hard drive carrier from the hard drive cage

Prerequisites

CAUTION: 許多維修僅可由獲得認可的維修技術人員來完成。您只能依照產品說明文件中的授權說明或在線上或電話服務和支援團隊的指導下，執行故障排除和簡單的維修。由未經 Dell 授權的維修造成的損壞不在保固範圍之內。請閱讀並遵循產品隨附的安全說明。

- 1 Ensure that you follow the [Safety instructions](#).
- 2 Follow the procedure listed in [拆裝系統內部元件之前](#).
- 3 Disconnect all peripherals connected to the control panel assembly.
- 4 Remove the bezel.
- 5 Remove the power and data cables from the hard drives and optical drive in the hard drive cage.
- 6 Remove the hard drive cage.

Step

Press the retention clips inward and pull the hard drive out of the hard drive cage.

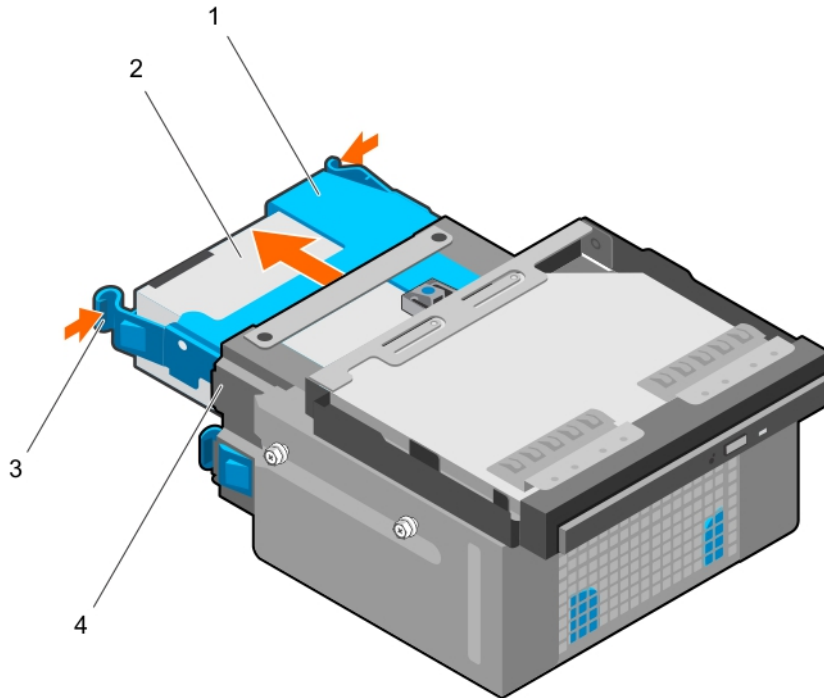

Figure 19. Removing hard drive carrier from the hard drive cage

- | | | | |
|---|---------------------|---|-----------------|
| 1 | hard drive carrier | 2 | hard drive |
| 3 | retention clips (2) | 4 | hard drive cage |

Next steps

- 1 Install the hard drive carrier into the hard drive cage.
- 2 Install the hard drive cage.
- 3 Reconnect the power and data cables to the hard drives and optical drive in the hard drive cage.
- 4 Install the bezel.
- 5 Reconnect the peripherals disconnected from the control panel assembly.
- 6 Follow the procedure listed in [拆裝系統內部元件之後](#).

Related links

- [Removing the bezel](#)
- [Removing the hard drive cage](#)
- [Installing a hard drive carrier into the hard drive cage](#)
- [Installing the hard drive cage](#)
- [Installing the bezel](#)

Installing a hard drive carrier into the hard drive cage

Prerequisites

CAUTION: 許多維修僅可由獲得認可的維修技術人員來完成。您只能依照產品說明文件中的授權說明或在線上或電話服務和支援團隊的指導下，執行故障排除和簡單的維修。由未經 Dell 授權的維修造成的損壞不在保固範圍之內。請閱讀並遵循產品隨附的安全說明。

- 1 Ensure that you follow the [Safety instructions](#).
- 2 Follow the procedure listed in [拆裝系統內部元件之前](#).
- 3 Disconnect all peripherals connected to the control panel assembly.
- 4 Remove the bezel.
- 5 Remove the power and data cables from the hard drives and optical drive in the hard drive cage.
- 6 Remove the hard drive cage.

Step

Insert the hard drive carrier into the hard drive cage until it clicks into place.

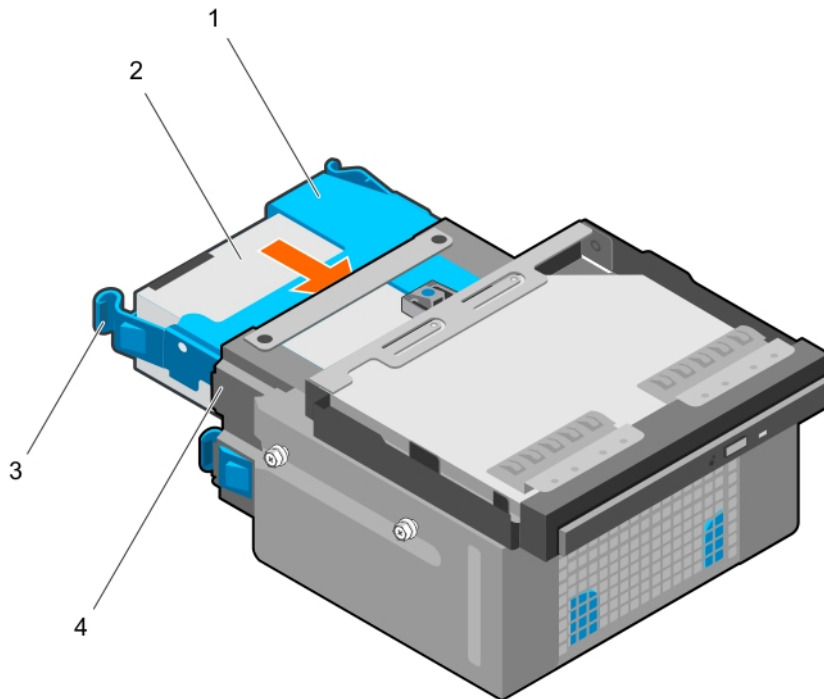

Figure 20. Installing a hard drive carrier into the hard drive cage

- | | | | |
|---|---------------------|---|-----------------|
| 1 | hard drive carrier | 2 | hard drive |
| 3 | retention clips (2) | 4 | hard drive cage |

Next steps

- 1 Install the hard drive cage.
- 2 Reconnect the power and data cables to the hard drives and optical drive in the hard drive cage.
- 3 Install the bezel.
- 4 Reconnect the peripherals disconnected from the control panel assembly.

- 5 Follow the procedure listed in [拆裝系統內部元件之後](#).

Related links

- [Removing the bezel](#)
- [Removing the hard drive cage](#)
- [Installing the hard drive cage](#)
- [Installing the bezel](#)

Removing a hard drive carrier from the hard drive bay

Prerequisites

△ CAUTION: 許多維修僅可由獲得認可的維修技術人員來完成。您只能依照產品說明文件中的授權說明或在線上或電話服務和支援團隊的指導下，執行故障排除和簡單的維修。由未經 **Dell** 授權的維修造成的損壞不在保固範圍之內。請閱讀並遵循產品隨附的安全說明。

- 1 Ensure that you follow the [Safety instructions](#).
- 2 Follow the procedure listed in [拆裝系統內部元件之前](#).
- 3 If connected, disconnect the power and data cables from the hard drive in the hard drive bay.

Step

Press the retention clips inward and lift the hard drive carrier from the hard drive bay.

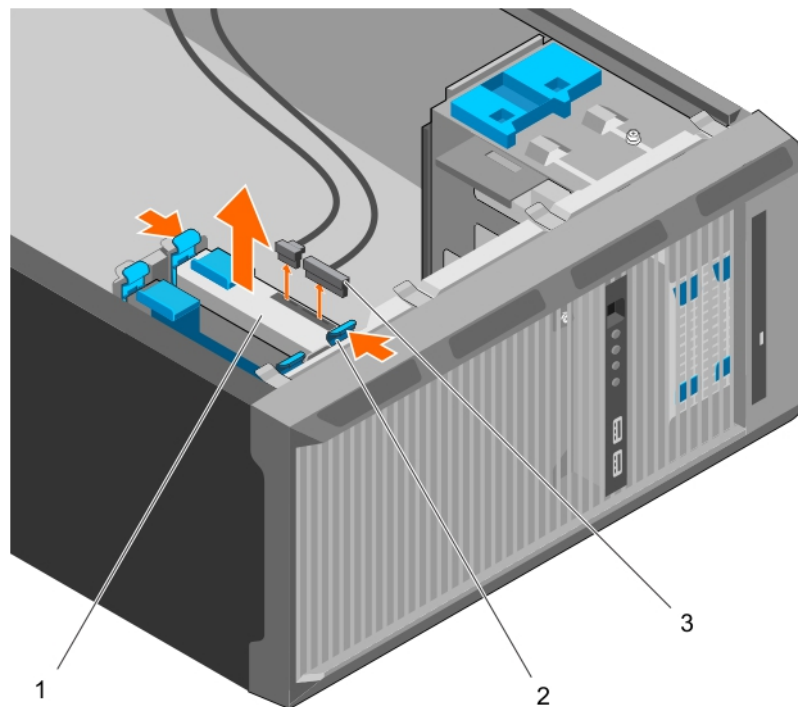

Figure 21. Removing a hard drive carrier from the hard drive bay

1 hard drive

2 retention clips on hard drive carrier (2)

- 3 hard drive power and data cables (2)

Next steps

- 1 Install the hard drive carrier into the hard drive bay.
- 2 If disconnected, connect the power and data cables to the hard drives in the hard drive bay.
- 3 Follow the procedure listed in [拆裝系統內部元件之後](#).

Related links

[Installing a hard drive carrier into the hard drive bay](#)

Installing a hard drive carrier into the hard drive bay

Prerequisites

△ CAUTION: 許多維修僅可由獲得認可的維修技術人員來完成。您只能依照產品說明文件中的授權說明或在線上或電話服務和支援團隊的指導下，執行故障排除和簡單的維修。由未經 Dell 授權的維修造成的損壞不在保固範圍之內。請閱讀並遵循產品隨附的安全說明。

- 1 Ensure that you follow the [Safety instructions](#).
- 2 Follow the procedure listed in [拆裝系統內部元件之前](#).

Step

Insert the hard drive carrier into the hard drive bay until it clicks into place.

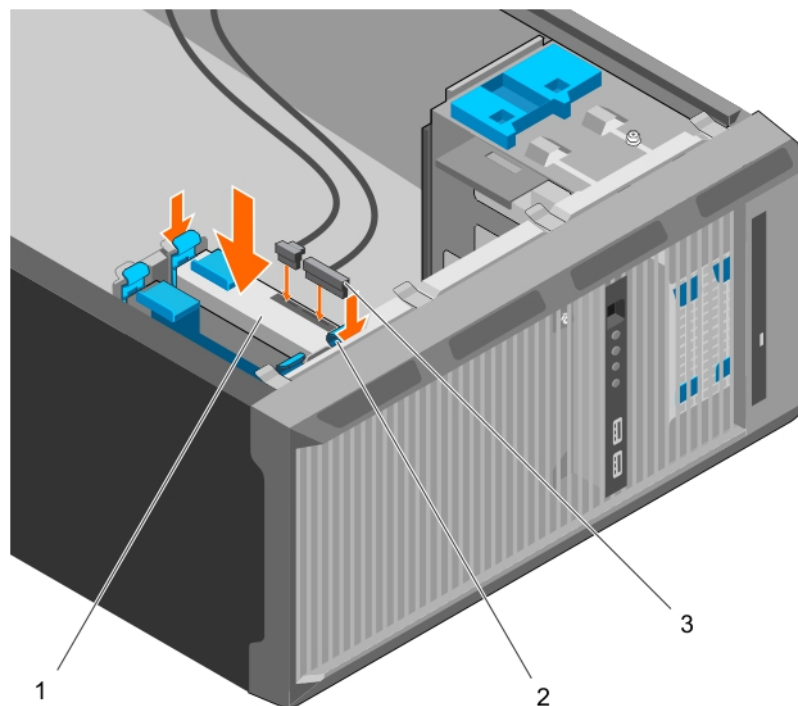

Figure 22. Installing a hard drive carrier into the hard drive bay

- 1 hard drive
- 2 retention clips on hard drive carrier (2)
- 3

- 3 hard drive power and data cables (2)

Next steps

- 1 If disconnected, connect the power and data cables to the hard drive in the hard drive bay.
- 2 Follow the procedure listed in [拆裝系統內部元件之後](#).

Removing a hard drive from a hard drive carrier

Prerequisites

△ CAUTION: 許多維修僅可由獲得認可的維修技術人員來完成。您只能依照產品說明文件中的授權說明或在線上或電話服務和支援團隊的指導下，執行故障排除和簡單的維修。由未經 **Dell** 授權的維修造成的損壞不在保固範圍之內。請閱讀並遵循產品隨附的安全說明。

- 1 Ensure that you follow the [Safety instructions](#).
- 2 Follow the procedure listed in [拆裝系統內部元件之前](#).
- 3 Depending on your requirement, remove the hard drive carrier from the hard drive cage or the hard drive bay.

Step

To release the hard drive, flex the sides of the hard drive carrier.

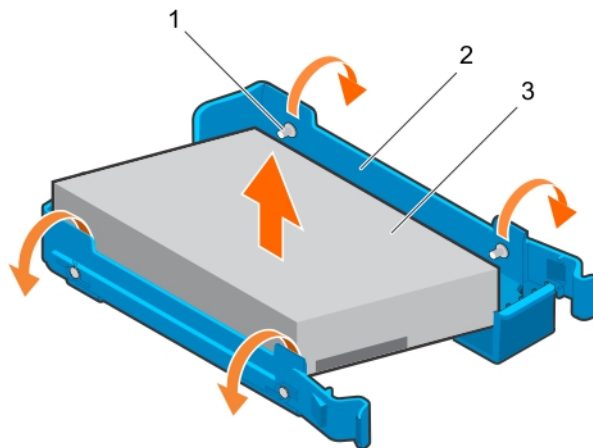

Figure 23. Removing and installing a hard drive from a hard drive carrier

- | | |
|--------------|----------------------|
| 1 pins (4) | 2 hard drive carrier |
| 3 hard drive | |

Next steps

- 1 Install the hard drive into the hard drive carrier.
- 2 Follow the procedure listed in [拆裝系統內部元件之後](#).

Related links

[Removing a hard drive carrier from the hard drive bay](#)
[Removing a hard drive carrier from the hard drive cage](#)
[Installing a hard drive into a hard drive carrier](#)

Installing a hard drive into a hard drive carrier

Prerequisites

CAUTION: 許多維修僅可由獲得認可的維修技術人員來完成。您只能依照產品說明文件中的授權說明或在線上或電話服務和支援團隊的指導下，執行故障排除和簡單的維修。由未經 Dell 授權的維修造成的損壞不在保固範圍之內。請閱讀並遵循產品隨附的安全說明。

- 1 Ensure that you follow the [Safety instructions](#).
- 2 Follow the procedure listed in [拆裝系統內部元件之前](#).
- 3 Depending on your requirement, remove the hard drive carrier from the hard drive cage or the hard drive bay.

Steps

- 1 Orient the hard drive so that the screw holes on one side of the hard drive align with the pins on the carrier.
- 2 Flex the other side of the hard drive carrier, and press the hard drive into the hard drive carrier to secure it.

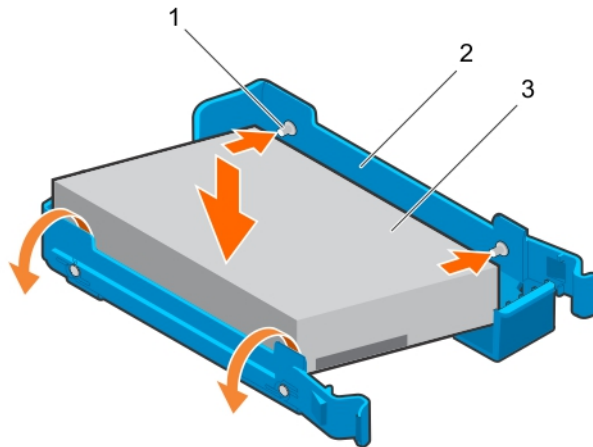

Figure 24. Installing a hard drive into a hard drive carrier

- | | |
|--------------|----------------------|
| 1 pins (4) | 2 hard drive carrier |
| 3 hard drive | |

Next steps

- 1 Depending on your requirement, install the hard drive carrier in the hard drive cage or the hard drive bay.
- 2 Follow the procedure listed in [拆裝系統內部元件之後](#).

硬碟佈線圖



圖 25. 光碟機以及從 PERC 卡的四個 3.5 吋 SATA 硬碟的佈線圖

- | | | | |
|---|--------------------|---|----------------|
| 1 | 主機板 | 2 | 主機板上的 SATA 連接器 |
| 3 | 光碟機上的 SATA 連接器 | 4 | 光碟機 |
| 5 | 硬碟 | 6 | 硬碟上的 SATA 連接器 |
| 7 | PERC 卡上的 SAS A 連接器 | 8 | PERC 卡 |

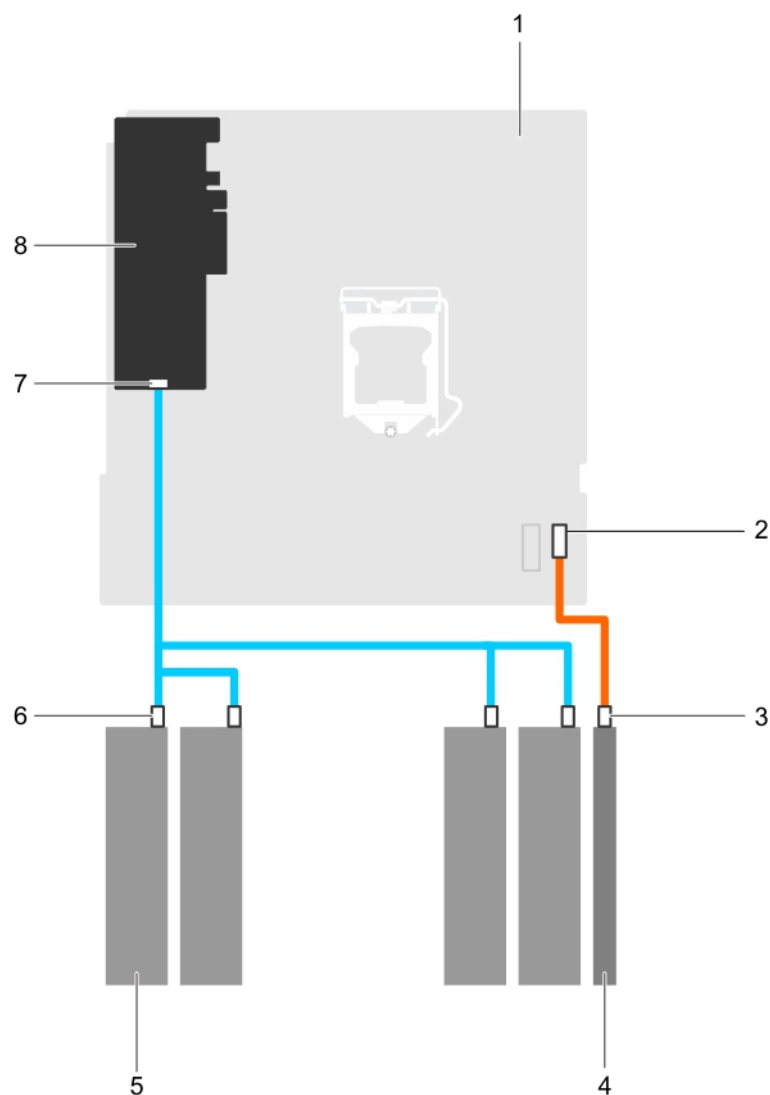

圖 26. 從主機板上連接四個 3.5 吋 SATA 硬碟的佈線圖

- | | | | |
|---|--------------------|---|-------------------|
| 1 | 主機板 | 2 | 主機板上的 SATA 光碟機連接器 |
| 3 | 主機板上的 mini SAS 連接器 | 4 | 光碟機上的 SATA 光碟機連接器 |
| 5 | 光碟機 | 6 | 硬碟 |
| 7 | 硬碟上的 SATA 連接器 | | |

設定 4 部 TB 硬碟的散熱風扇速度

① | 註: Dell 建議僅將 4 部 TB 硬碟用於搭載 PERC 控制器的系統。

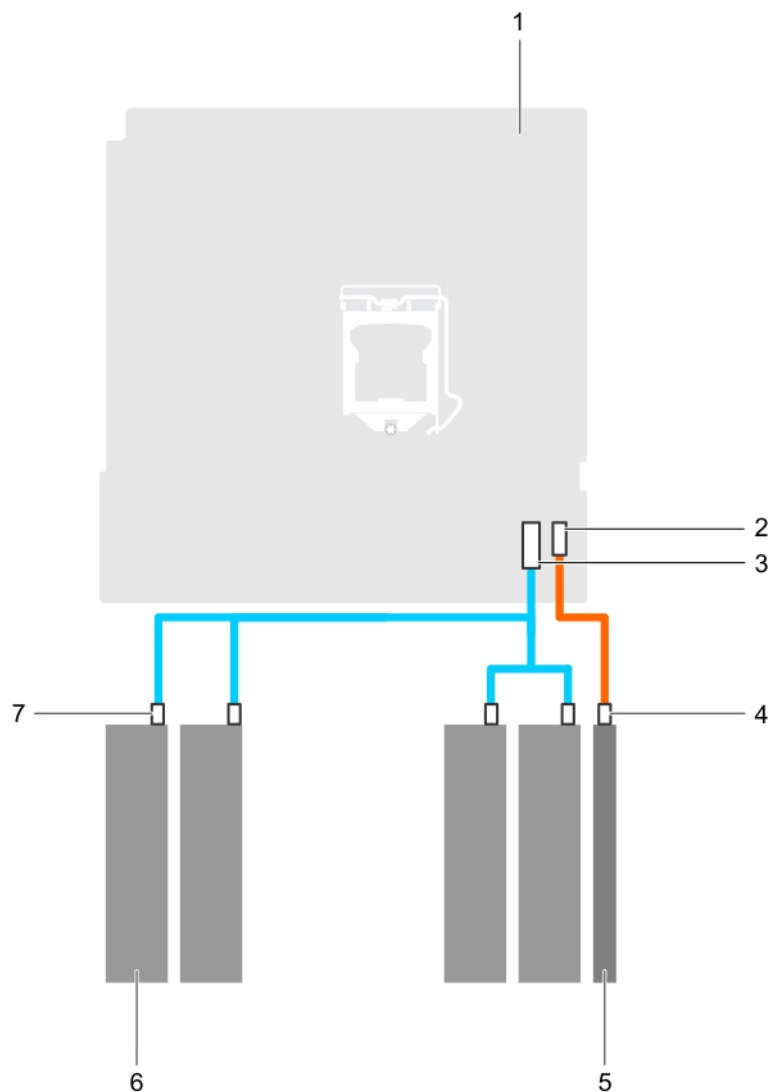
△ | 警告: 在沒有 PERC 控制器的系統中使用 4 部 TB 硬碟可能會導致硬碟 1 在過度工作負載過熱，導致硬碟可能因此故障。

關於此工作

當在沒有 PERC 控制器的系統中使用 4 部 TB 硬碟時，必須以手動方式調整散熱風扇的速度，以防止硬碟過熱。

步驟

- 1 若要進入 iDRAC 功能選單，請在 POST 期間按下 F2 或 F11。
- 2 選取 iDRAC 設定。
- 3 選取**散熱**部分。
- 4 選取**風扇設定程式**設定。
- 5 在**風扇速度偏移**部分，選擇**低風扇速度偏移 (+15%)**。

光碟機

Removing the optical drive blank and filler

The optical drive blank is on the bezel and the optical drive filler is located in the optical drive slot on the hard drive cage.

Prerequisites

- 1 Ensure that you follow the [Safety instructions](#).
- 2 Follow the procedure listed in [拆裝系統內部元件之前](#).
- 3 Disconnect all peripherals connected to the control panel assembly.
- 4 Remove the bezel.
- 5 If connected, disconnect the power and data cable from the optical drive and hard drives.
- 6 Remove the hard drive cage.

Steps

- 1 On the bezel, press down on the retention clip of the optical drive blank and pull the blank out of the bezel.

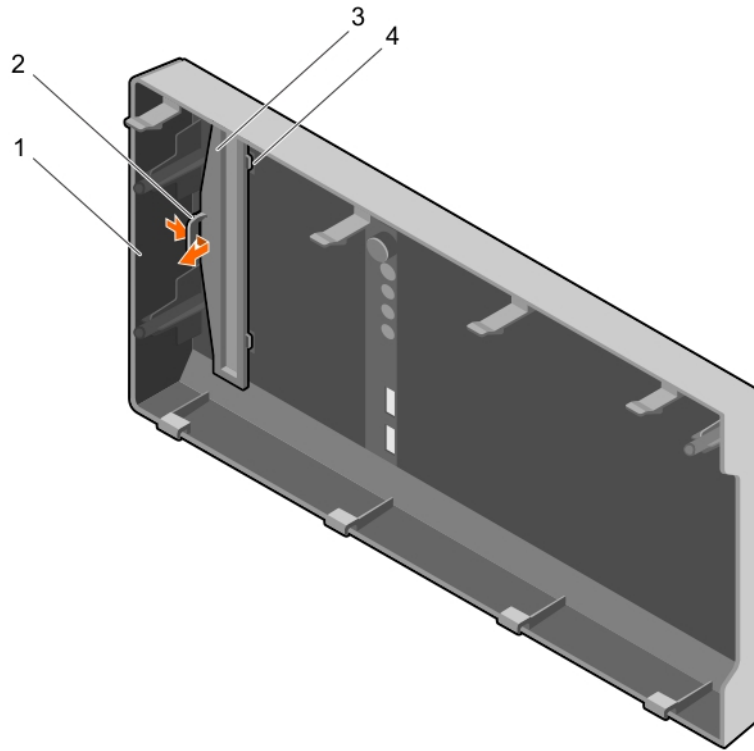

Figure 27. Removing the optical drive blank from the bezel

1 bezel

3 optical drive blank

2 retention clip

4 optical drive blank locking tab (2)

- 2 On the hard drive cage, hold the tabs on the optical drive filler and remove the optical drive filler from the hard drive cage.

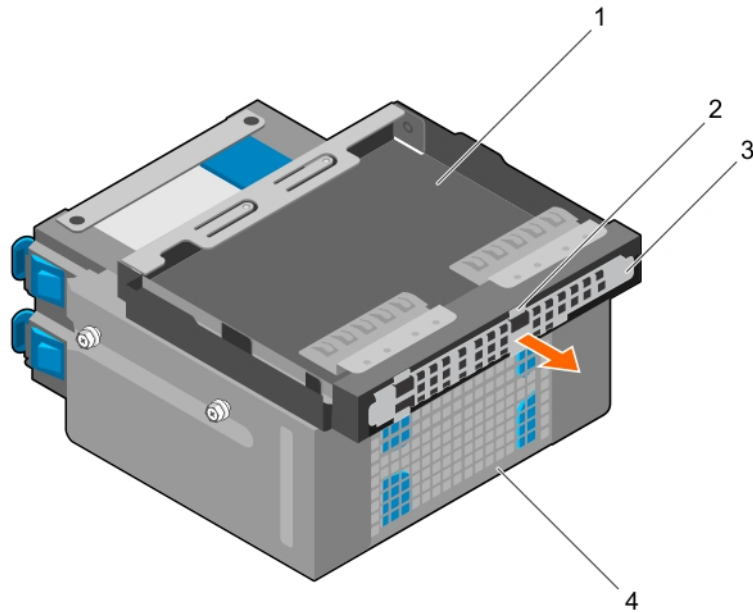

Figure 28. Removing the optical drive filler

- | | | | |
|---|----------------------|---|-----------------|
| 1 | optical drive bay | 2 | tabs (4) |
| 3 | optical drive filler | 4 | hard drive cage |

Next steps

- 1 Install the hard drive cage.
- 2 Reconnect the disconnected data and power cables to the hard drives and optical drive.
- 3 Install the bezel.
- 4 Reconnect all peripherals disconnected from the control panel assembly.
- 5 Follow the procedure listed in [拆裝系統內部元件之後](#).

Related links

- [Removing the bezel](#)
- [Removing the hard drive cage](#)
- [Installing the hard drive cage](#)
- [Installing the bezel](#)

Installing the optical drive blank and filler

The optical drive blank is on the bezel and the optical drive filler is located in the optical drive slot on the hard drive cage.

Prerequisites

- 1 Ensure that you follow the [Safety instructions](#).
- 2 Follow the procedure listed in [拆裝系統內部元件之前](#).
- 3 Disconnect all peripherals connected to the control panel assembly.
- 4 Remove the bezel.
- 5 If connected, disconnect the power and data cable from the optical drive and hard drives.
- 6 Remove the hard drive cage.

7 Remove the optical drive.

Steps

1 On the bezel, insert the tabs on optical drive blank into the slots on the bezel and push the blank until it locks into place.

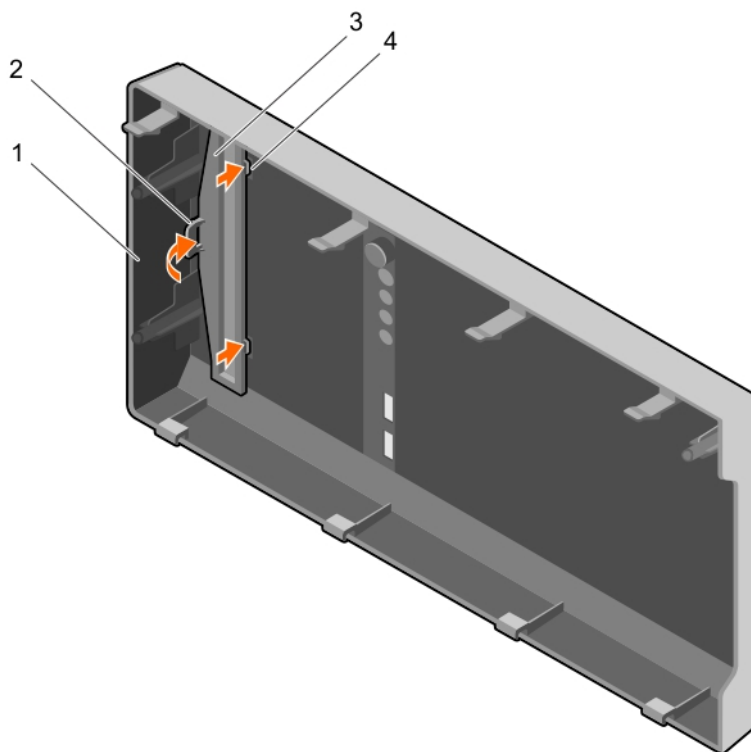

Figure 29. Installing the optical drive blank in the bezel

1 bezel

2 retention clip

3 optical drive blank

4 optical drive blank locking tab (2)

2 On the hard drive cage, hold the tabs on the optical drive filler and insert the optical drive filler into the slot on the hard drive cage.

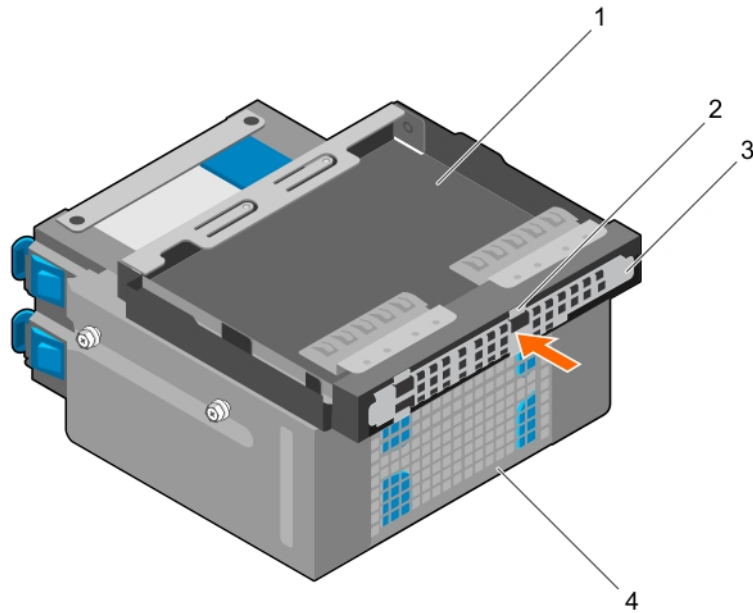

Figure 30. Installing the optical drive filler

- | | | | |
|---|----------------------|---|-----------------|
| 1 | optical drive bay | 2 | tabs (4) |
| 3 | optical drive filler | 4 | hard drive cage |

Next steps

- 1 Install the hard drive cage.
- 2 Reconnect the disconnected data and power cables to the hard drives and optical drive.
- 3 Install the bezel.
- 4 Reconnect all peripherals disconnected from the control panel assembly.
- 5 Follow the procedure listed in [拆裝系統內部元件之後](#).

Removing the optical drive

Prerequisites

△ CAUTION: 許多維修僅可由獲得認可的維修技術人員來完成。您只能依照產品說明文件中的授權說明或在線上或電話服務和支援團隊的指導下，執行故障排除和簡單的維修。由未經 **Dell** 授權的維修造成的損壞不在保固範圍之內。請閱讀並遵循產品隨附的安全說明。

- 1 Ensure that you follow the [Safety instructions](#).
- 2 Follow the procedure listed in [拆裝系統內部元件之前](#).
- 3 Disconnect all peripherals connected to the I/O module.
- 4 Remove the bezel.
- 5 If connected, disconnect the power and data cables from the optical drive and hard drives.
- 6 Remove the hard drive cage.

Step

Press down and push the blue release tab and push the optical drive out of the hard drive cage.

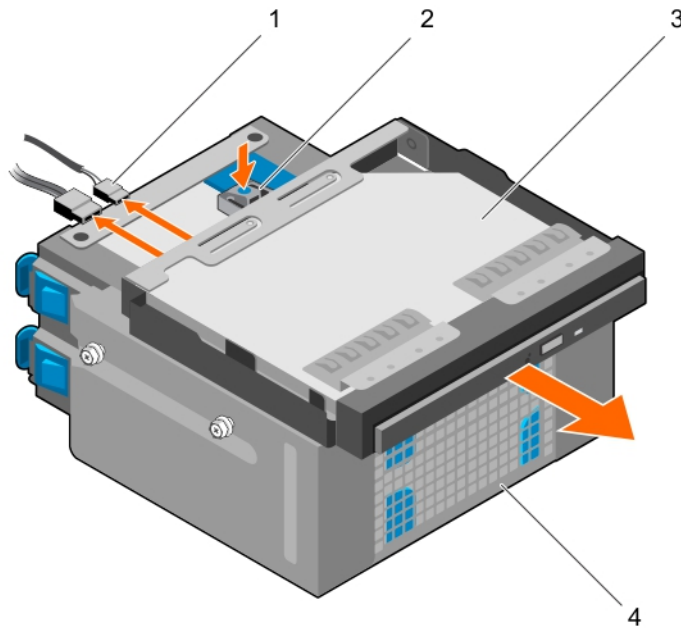

Figure 31. Removing the optical drive

- | | | | |
|---|----------------------|---|-----------------|
| 1 | SATA and power cable | 2 | release tab |
| 3 | optical drive | 4 | hard drive cage |

Next steps

- 1 Install the optical drive.
- 2 Install the hard drive cage.
- 3 Reconnect the disconnected data and power cables to the hard drives and optical drive.
- 4 Install the bezel.
- 5 Reconnect the peripherals disconnected from the control panel assembly.
- 6 Follow the procedure listed in [拆裝系統內部元件之後](#).

Related links

- [Removing the bezel](#)
- [Removing the hard drive cage](#)
- [Installing the optical drive](#)
- [Installing the hard drive cage](#)
- [Installing the bezel](#)

Installing the optical drive

Only slim 9.5 mm SATA DVD-ROM drive or DVD+/-RW drive can be installed in your system. External optical drives can be connected through USB ports.

Prerequisites

△ CAUTION: 許多維修僅可由獲得認可的維修技術人員來完成。您只能依照產品說明文件中的授權說明或在線上或電話服務和支援團隊的指導下，執行故障排除和簡單的維修。由未經 **Dell** 授權的維修造成的損壞不在保固範圍之內。請閱讀並遵循產品隨附的安全說明。

- 1 Ensure that you follow the [Safety instructions](#).

- 2 Follow the procedure listed in [拆裝系統內部元件之前](#).
- 3 Disconnect all peripherals connected to the I/O module.
- 4 Remove the bezel.
- 5 If connected, disconnect the power and data cables from the optical drive and hard drives.
- 6 Remove the hard drive cage.
- 7 If installed, remove the optical drive blank from the bezel and the optical drive filler from the hard drive cage.

Steps

- 1 Align the optical drive with the optical drive slot on the front of the chassis.
- 2 Slide the optical drive into the slot until the release tab locks into place.
- 3 Connect the power and data cables to the optical drive.
- 4 Route the power and data cables through the cable routing guides on the system chassis.

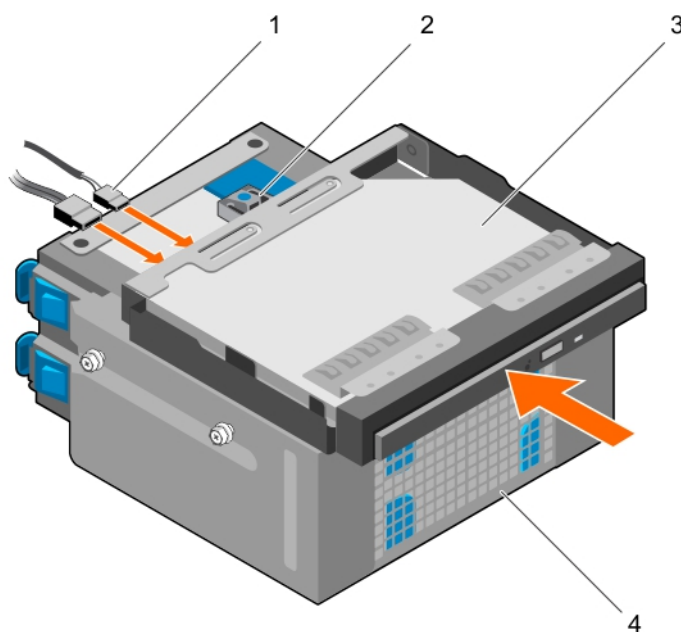

Figure 32. Installing the optical drive

- | | | | |
|---|----------------------|---|-----------------|
| 1 | SATA and power cable | 2 | release tab |
| 3 | optical drive | 4 | hard drive cage |

Next steps

- 1 Install the hard drive cage.
- 2 If disconnected, reconnect the disconnected data and power cables to the hard drives and optical drive.
- 3 Install the bezel.
- 4 Reconnect the peripherals disconnected from the control panel assembly.
- 5 Follow the procedure listed in [拆裝系統內部元件之後](#).

Related links

- [Removing the bezel](#)
- [Removing the hard drive cage](#)
- [Removing the optical drive blank and filler](#)
- [Installing the optical drive](#)
- [Installing the hard drive cage](#)
- [Installing the bezel](#)

System memory

Your system supports DDR4 ECC unbuffered DIMMs (UDIMMs).

NOTE: MT/s indicates memory module speed in Mega Transfers per second.

Memory bus operating frequency can be 1600 MT/s, 1866 MT/s, 2133 MT/s, or 2400 MT/s depending on the following factors:

- System profile selected (for example, Performance Optimized, Custom, or Dense Configuration Optimized)
- Maximum supported memory module frequency of the processors

The system contains four memory sockets — two sets of 2-sockets each. Each 2-socket set is organized into one channel. In each 2-socket set, the first socket release lever is marked white and the second socket release lever is marked black.

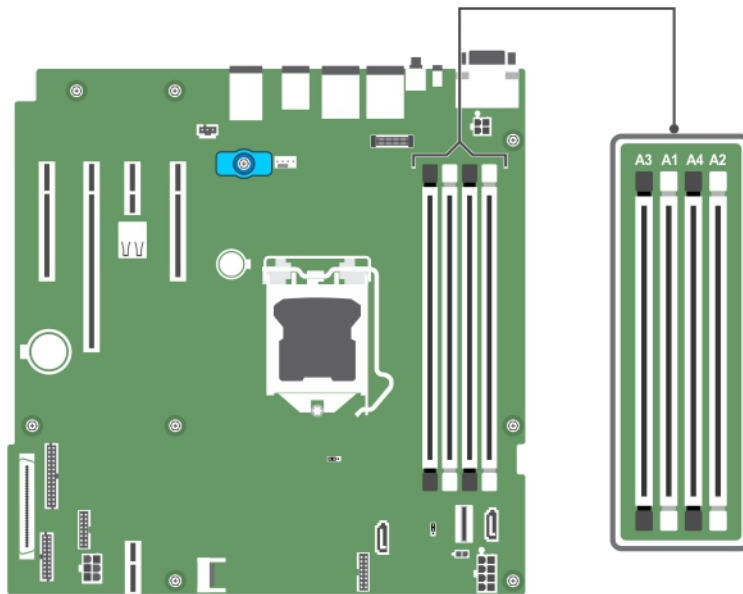

Figure 33. Memory socket locations on the system board

Memory channels are organized as follows:

- Processor 1**
- channel 0: memory sockets A1 and A3
 - channel 1: memory sockets A2 and A4

The following table shows the memory populations and operating frequencies for the supported configurations:

Table 15. Memory populations and operating frequencies for the supported configurations

Memory module type	Memory modules populated per channel	Operating frequency (in MT/s)	Maximum memory module ranks per channel
		1.2 V	
ECC (UDIMM)	1	1600, 1866, 2133, 2400	Dual rank or single rank
	2	1600, 1866, 2133, 2400	Dual rank or single rank

一般記憶體模組安裝指引

您的系統支援彈性記憶體組態，可讓系統在任何有效的晶片組架構組態中組態及運作。以下是安裝記憶體模組的建議指引：

- x4 和 x8 DRAM 型 DIMM 可以混用。
- 每個通道最多可安裝三個雙排或單排 RDIMM。
- 僅在安裝一個處理器的時候填入 DIMM 插槽。在單處理器系統上，A1 至 A4 插槽均為可用。
- 先填入所有附白色釋放拉桿的插槽，然後是所有附黑色釋放拉桿的插槽。
- 混用不同容量的記憶體模組時，先將容量最高的記憶體模組裝入插槽。例如，若要混用 4 GB 和 8 GB DIMM，請將 8 GB DIMM 裝入具有白色釋放拉桿的插槽，然後將 4 GB DIMM 裝入具有黑色釋放拉桿的插槽。
- 在遵循其他記憶體規則的情況下，可以混用不同容量的記憶體模組（例如，可以混用 4 GB 和 8 GB 記憶體模組）。
- 不支援在系統中混用超過兩種 DIMM 容量。
- 一次填充每個處理器的四個 DIMM（每通道一個 DIMM），以發揮最大效能。

Sample memory configurations

The following table shows sample memory configurations for a single processor configuration.

NOTE: 1R and 2R in the following table indicate single and dual-rank memory modules respectively.

Table 16. Memory configurations—single processor

Populated system capacity (in GB)	Memory module size (in GB)	Number of memory modules	Memory module rank, organization, and frequency	memory module slot population
4	4	1	1R, x8, 2400 MT/s	A1
			1R, x8, 2133 MT/s	
			1R, x8, 1866 MT/s	
8	4	2	1R, x8, 2400 MT/s	A1, A2
			2R, x8, 2400 MT/s	
	8	1	1R, x8, 2400 MT/s	A1
			1R, x8, 2133 MT/s	
			2R, x8, 2133 MT/s	
			1R, x8, 1866 MT/s	

Populated system capacity (in GB)	Memory module size (in GB)	Number of memory modules	Memory module rank, organization, and frequency	memory module slot population	
16	4	4	2R, x8, 1866 MT/s	A1, A2, A3, A4	
			1R, x8, 2400 MT/s		
			2R, x8, 2400 MT/s		
	8	2	1R, x8, 2400 MT/s		A1, A2
			1R, x8, 2133 MT/s		
			2R, x8, 2133 MT/s		
32	16	1	2R, x8, 2400 MT/s	A1	
			1R, x8, 1866 MT/s		
			2R, x8, 1866 MT/s		
	8	4	1R, x8, 2400 MT/s	A1, A2, A3, A4	
			2R, x8, 2400 MT/s		
			16	2	2R, x8, 2400 MT/s
1R, x8, 2133 MT/s					
64	16	4	2R, x8, 2400 MT/s	A1, A2, A3, A4	
			1R, x8, 2133 MT/s		
			2R, x8, 2133 MT/s		
			1R, x8, 1866 MT/s		
			2R, x8, 1866 MT/s		
			2R, x8, 1866 MT/s		

卸下記憶體模組

警告: 許多維修僅可由獲得認可的維修技術人員來完成。您只能依照產品說明文件中的授權說明或在線上或電話服務和支援團隊的指導下，執行故障排除和簡單的維修。由未經 **Dell** 授權的維修造成的損壞不在保固範圍之內。請閱讀並遵循產品隨附的安全說明。

- 請確定您遵循 [Safety instructions](#)。
- 請遵循 [拆裝系統內部元件之前](#) 中的程序進行操作。

警告: 即使系統已關機經過一段時間，記憶體模組有時溫度仍可能很高，因此不該觸碰。請待記憶體模組冷卻後，再進行後續處理。請握住記憶體模組插卡邊緣，並避免碰觸其元件或金屬觸點。

步驟

1 找到適當的記憶體模組插槽。

△ 警告: 請從邊緣拿起記憶體模組，確定不要碰到記憶體模組中央或金屬接點。

2 若要從插槽鬆開記憶體模組，請同時壓下記憶體模組插槽兩端的退出拉桿。

3 將記憶體模組從機箱取出。



圖 34. 卸下一個記憶體模組

1 記憶體模組

2 記憶體模組插槽

3 記憶體模組插槽退出拉桿 (2)

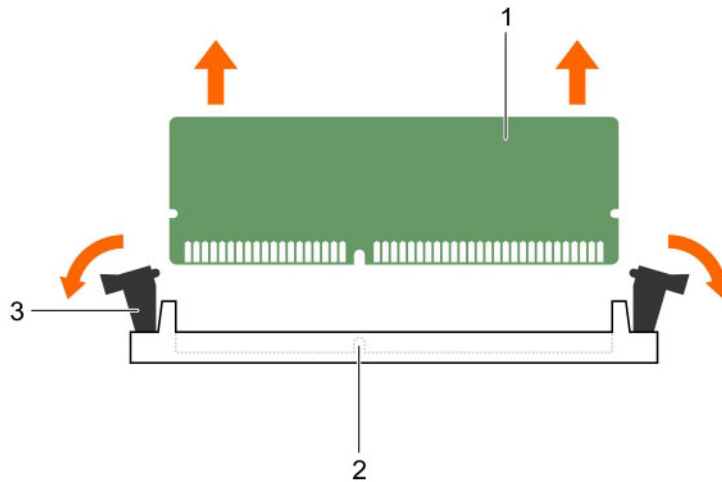
1 安裝記憶體模組。

2 請遵循[拆裝系統內部元件之後](#)中的程序進行操作。

相關連結

[安裝記憶體模組](#)

安裝記憶體模組

△ 警告: 許多維修僅可由獲得認可的維修技術人員來完成。您只能依照產品說明文件中的授權說明或在線上或電話服務和支援團隊的指導下，執行故障排除和簡單的維修。由未經 **Dell** 授權的維修造成的損壞不在保固範圍之內。請閱讀並遵循產品隨附的安全說明。

1 請確定您遵循 [Safety instructions](#)。

2 請遵循[拆裝系統內部元件之前](#)中的程序進行操作。

△ 警告: 即使系統已關機經過一段時間，記憶體模組有時溫度仍可能很高，因此不該觸碰。請待記憶體模組冷卻後，再進行後續處理。請握住記憶體模組插卡邊緣，並避免碰觸其元件或金屬觸點。

步驟

1 找到適當的記憶體模組插槽。

△ 警告: 請從邊緣拿起記憶體模組，確定不要碰到記憶體模組中央或金屬接點。

- △ **警告:** 在安裝期間，為避免損壞記憶體模組或記憶體模組插槽，請勿彎折或彎曲記憶體模組；同時插入記憶體模組的兩端。
- 2 將記憶體模組的邊緣連接器與記憶體模組插槽的對準點對齊，然後將記憶體模組插入插槽中。
- ① **註:** 對齊金鑰可讓您只能以單一方向插槽中安裝記憶體模組。
- △ **警告:** 請勿用力按壓記憶體模組中央；請平均施力按壓記憶體模組兩端。
- 3 用拇指按壓記憶體模組，直到插槽拉桿穩固地卡入到位。



圖 35. 安裝記憶體模組

- 1 記憶體模組
- 2 對準點
- 3 記憶體模組插槽退出拉桿 (2)

- 1 請遵循 [拆裝系統內部元件之後](#) 中的程序進行操作。
- 2 按 F2 進入 **System Setup (系統設定)**，然後檢查 System Memory (系統記憶體) 設定。
系統記憶體大小應反映已安裝的記憶體。
- 3 如果值不正確，一或多個記憶體模組可能無法正確安裝。請確定記憶體模組均已穩固地插入插槽。
- 4 執行系統診斷程式中的系統記憶體測試。請參閱 [Dell 嵌入式系統診斷程式](#)。

散熱風扇

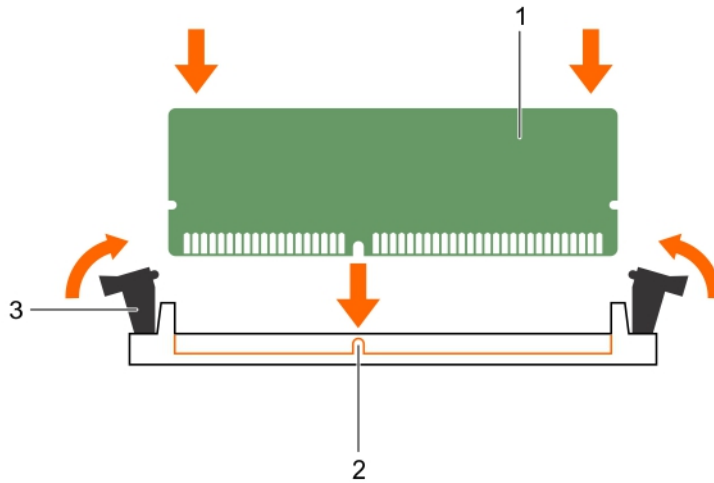
您的系統只支援一個散熱風扇。

Removing the cooling fan

Prerequisites

- △ **CAUTION:** 許多維修僅可由獲得認可的維修技術人員來完成。您只能依照產品說明文件中的授權說明或在線上或電話服務和支援團隊的指導下，執行故障排除和簡單的維修。由未經 Dell 授權的維修造成的損壞不在保固範圍之內。請閱讀並遵循產品隨附的安全說明。

△ **CAUTION:** Do not remove or install the cooling fan by holding the blades.

△ **CAUTION:** Never operate your system with the system fan removed. System can overheat and result in shutdown of the system and loss of data.

- 1 Ensure that you follow the [Safety instructions](#).
- 2 Follow the procedure listed in [拆裝系統內部元件之前](#).

Steps

- 1 Disconnect the cooling fan power cable from the system board.
- 2 To ease removal of the cooling fan, stretch the grommets securing the fan to the chassis.
- 3 Hold the cooling fan by the sides, and slide it out of the grommet.
- 4 Repeat steps 2 and 3 to release the fan from the remaining grommets.

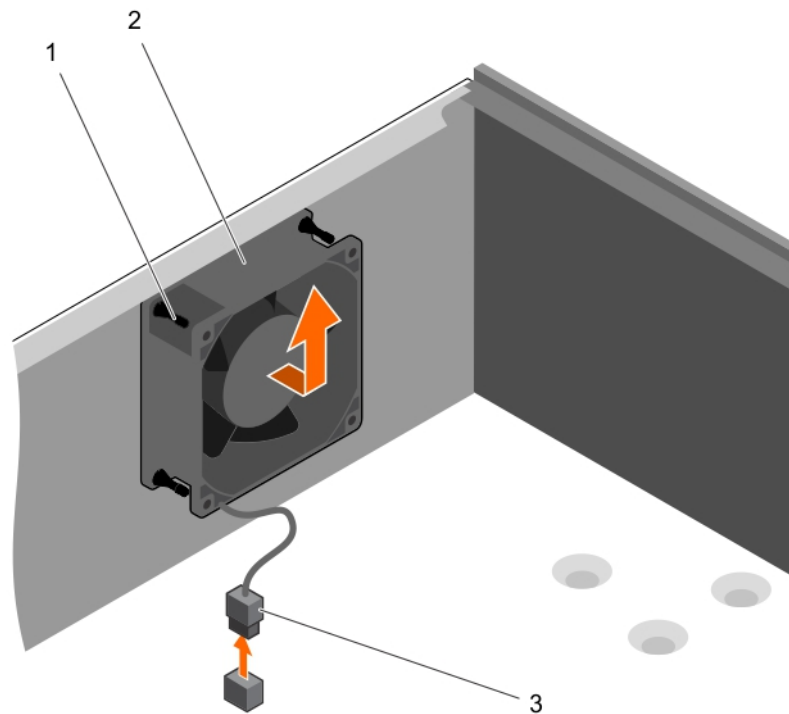

Figure 36. Removing the cooling fan

- | | | | |
|---|-------------------------|---|-------------|
| 1 | grommets (4) | 2 | cooling fan |
| 3 | cooling fan power cable | | |

Next steps

- 1 Install the cooling fan.
- 2 Follow the procedure listed in [拆裝系統內部元件之後](#).

Related links

[Installing the cooling fan](#)

Installing the cooling fan

Prerequisites

△ **CAUTION:** 許多維修僅可由獲得認可的維修技術人員來完成。您只能依照產品說明文件中的授權說明或在線上或電話服務和支援團隊的指導下，執行故障排除和簡單的維修。由未經 Dell 授權的維修造成的損壞不在保固範圍之內。請閱讀並遵循產品隨附的安全說明。

△ **CAUTION:** Do not remove or install the system fan by holding the blades.

- 1 Ensure that you follow the [Safety instructions](#).
- 2 Follow the procedure listed in [拆裝系統內部元件之前](#).

① **NOTE:** Install the lower two grommets first.

Steps

- 1 Hold the cooling fan by the sides with the cable end facing the bottom of the chassis.
- 2 Align the four grommets on the chassis with the four holes on the sides of the cooling fan.
- 3 Pass the grommets through the corresponding holes on the cooling fan.
- 4 Stretch the grommets and slide the cooling fan toward the chassis until it locks into place.
- 5 Connect the cooling fan power cable to the connector on the system board.

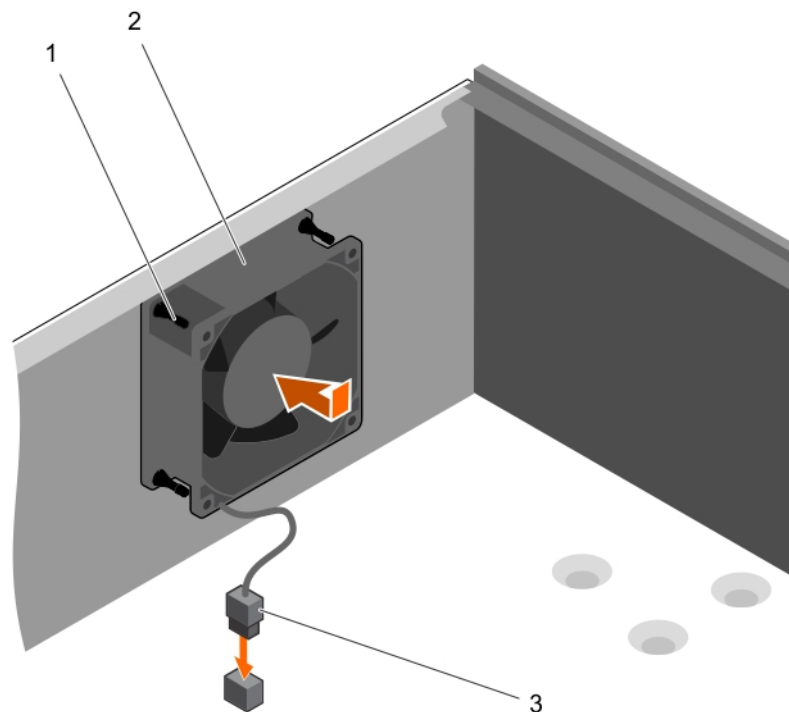

Figure 37. Installing the cooling fan

- | | | | |
|---|-------------------------|---|-------------|
| 1 | grommets (4) | 2 | cooling fan |
| 3 | cooling fan power cable | | |

Next step

Follow the procedure listed in [拆裝系統內部元件之後](#).

內部 USB 記憶體鑰匙 (可選)

安裝在系統內部的選用 USB 記憶體鑰匙可做為啟動裝置、安全金鑰，或大量儲存裝置。USB 連接器必須在系統設定中內建裝置畫面的內部 USB 連接埠選項啟用。

如要從 USB 記憶體鑰匙啟動，請設定有開機影像的 USB 記憶體鑰匙，然後在系統設定的啟動順序中指定 USB 記憶體鑰匙。

① 註：如要找到主機板上的 USB (INT_USB) 連接器，請參閱主機板跳線和連接器。

Replacing the optional internal USB memory key

Prerequisites

△ **CAUTION:** 許多維修僅可由獲得認可的維修技術人員來完成。您只能依照產品說明文件中的授權說明或在線上或電話服務和支援團隊的指導下，執行故障排除和簡單的維修。由未經 Dell 授權的維修造成的損壞不在保固範圍之內。請閱讀並遵循產品隨附的安全說明。

- 1 Follow the safety guidelines listed in the Safety instructions section.
- 2 Follow the procedure listed in the Before working inside your system section.

Steps

- 1 Locate the USB connector or USB memory key on the system board.

① **NOTE:** To locate the internal USB connector on the system board, see the System board connectors section.

- 2 If installed, remove the USB memory key from the USB connector.
- 3 Insert the replacement USB memory key into the USB connector.

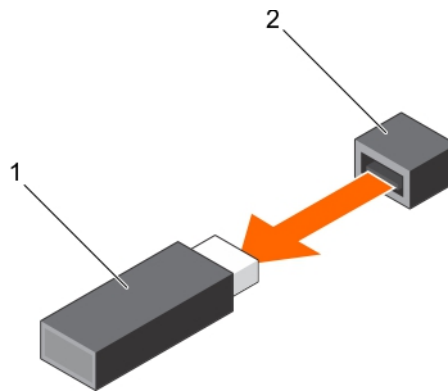

Figure 38. Removing the internal USB memory key

1 USB memory key

2 USB port

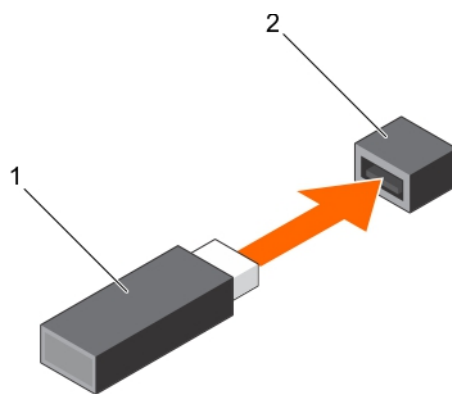

Figure 39. Installing the internal USB memory key

1 USB memory key

2 USB port

Next steps

- 1 Follow the procedure listed in the After working inside your system section.
- 2 While booting, press F2 to enter System Setup and verify that the USB memory key is detected by the system.

擴充卡

① 註: 如果擴充卡不受支援或遺失，會記錄 SEL 事件。它不會防止您的系統開啟，同時不會顯示 BIOS POST 訊息或 F1/F2 暫停。

擴充卡安裝指引

您的系統支援第 3 代插卡，下表列出支援的擴充卡：

表 17. PCI Express 第 3 代擴充卡支援

PCIe 插槽	處理器連接	高度	長度	連結寬度	插槽寬度
1	處理器	全高	半長	X4	x8
2	處理器	全高	半長	x8	x16
3	平台控制器集線器	全高	半長	X1	X1
4	平台控制器集線器	全高	半長	X4	x8

① 註: 所有插槽支援第 3 代 PCIe 擴充卡。

① 註: 擴充卡並非熱插拔。

下表提供安裝擴充卡的指南，以確保適當的冷卻且符合機械性。遵循下列插卡的優先順序及插槽優先順序安裝擴充卡，如下圖所示。

表 18. 擴充卡安裝順序

插卡優先順序	插卡類型	規格尺寸	插槽優先順序	最大允許
1	PowerEdge RAID 控制器 (PERC) H730	全高	4, 2, 1	1

	PERC H330	全高	4, 2, 1	1
	PERC H830	全高	2, 1, 4	2
2	1 GB NICs 四連接埠 (Intel)	全高	1, 2, 4	3
	1G NICs 四連接埠 (Broadcom)	全高	1, 2, 4	3
	1GB NICs 雙連接埠 (Intel)	全高	1, 2, 4	3
	1G NICs 雙連接埠 (Broadcom)	全高	3, 1, 4, 2	3
3	12 Gb SAS HBA	全高	2, 1, 4	3

Removing an expansion card

Prerequisites

△ CAUTION: 許多維修僅可由獲得認可的維修技術人員來完成。您只能依照產品說明文件中的授權說明或在線上或電話服務和支援團隊的指導下，執行故障排除和簡單的維修。由未經 **Dell** 授權的維修造成的損壞不在保固範圍之內。請閱讀並遵循產品隨附的安全說明。

- 1 Ensure that you follow the [Safety instructions](#).
- 2 Follow the procedure listed in [Before working inside your 系統](#).

Steps

- 1 Disconnect all the cables from the expansion card.
- 2 Press and push out the expansion card release latch.
- 3 Holding the card by its edge, pull the card to disengage it from the connector and lift the card out of the chassis.
- 4 If you are removing the card permanently, install an expansion card blank in the empty card slot.
The steps for installing or removing an expansion card blank are similar to installing or removing an expansion card.

ⓘ NOTE: Expansion card blanks must be installed into empty expansion card slots to maintain FCC certification of the system. The blanks also keep dust and dirt out of the system and aid in proper cooling and airflow inside the system.

- 5 Push the expansion card latch toward the system until it clicks into place.

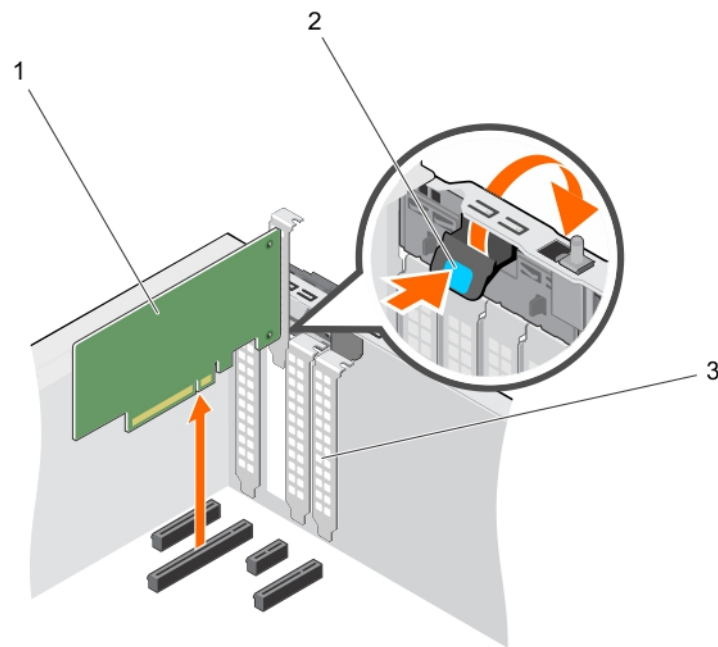

Figure 40. Removing an expansion card

- | | |
|--|--|
| <ol style="list-style-type: none"> 1 expansion card 3 expansion card blank | <ol style="list-style-type: none"> 2 expansion card latch |
|--|--|

Next steps

- 1 Install an expansion card.
- 2 Follow the procedure listed in [After working inside your 系統](#).

Related links

[Installing an expansion card](#)

Installing an expansion card

Prerequisites

△ CAUTION: 許多維修僅可由獲得認可的維修技術人員來完成。您只能依照產品說明文件中的授權說明或在線上或電話服務和支援團隊的指導下，執行故障排除和簡單的維修。由未經 **Dell** 授權的維修造成的損壞不在保固範圍之內。請閱讀並遵循產品隨附的安全說明。

- 1 Ensure that you follow the [Safety instructions](#).
- 2 Follow the procedure listed in [Before working inside your 系統](#).

Steps

- 1 Unpack the expansion card and prepare it for installation.
For instructions, see the documentation accompanying the card.
- 2 Press and push out the expansion card release latch to open it.
- 3 Remove the expansion card blank if you are installing a new expansion card.
The steps for installing or removing an expansion card blank are similar to installing or removing an expansion card.

NOTE: Keep the expansion card blank for future use. Expansion card blank must be installed into empty expansion card slots to maintain FCC certification of the system. The blanks also keep dust and dirt out of the system and aid in proper cooling and airflow inside the system.

- 4 Holding the expansion card by its edges, position the card so that the card-edge connector aligns with the expansion card connector.
- 5 Push the expansion card into the expansion card slot until the expansion card is fully seated.
- 6 Press the expansion card latch down toward the system until it clicks into place.

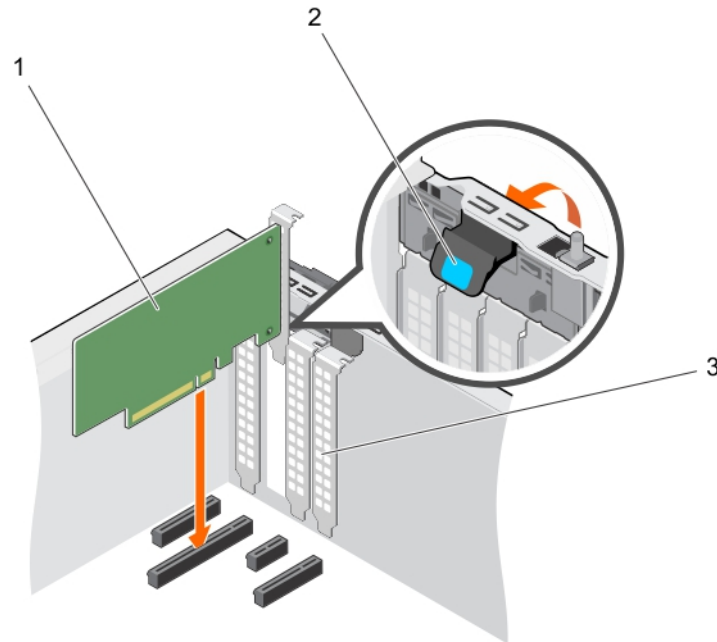

Figure 41. Installing an expansion card

- | | | | |
|---|----------------------|---|----------------------|
| 1 | expansion card | 2 | expansion card latch |
| 3 | expansion card blank | | |

Next step

Follow the procedure listed in [After working inside your 系統](#).

SD vFlash card (optional)

An SD vFlash card is a Secure Digital (SD) card that plugs into the SD vFlash card slot in the iDRAC port card. It provides persistent on-demand local storage and a custom deployment environment that enables automation of server configuration, scripts, and imaging. It emulates USB device(s). For more information, see the Integrated Dell Remote Access Controller User's Guide at Dell.com/idracmanuals.

Removing the optional SD vFlash card

- 1 Follow the safety guidelines listed in the Safety instructions section.
- 2 Locate the SD vFlash card slot at the back of the chassis.

To remove the SD vFlash card, push the SD vFlash card inward to release it, and pull the SD vFlash card from the SD vFlash card slot.

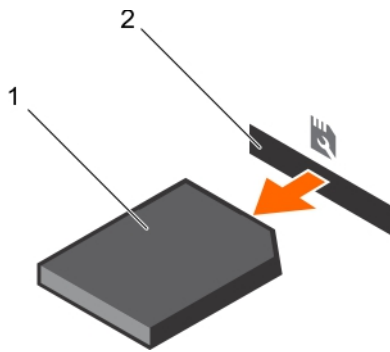

42. Removing the optional SD vFlash card

1 SD vFlash card

2 SD vFlash card slot

Installing an optional SD vFlash card

Prerequisites

- 1 Follow the safety guidelines listed in the Safety instructions section.
- 2 Locate the SD vFlash card slot at the back of the chassis.

Steps

- 1 Install a the SD vFlash card by inserting the contact-pin end of the SD vFlash card into the SD vFlash card slot on the iDRAC port card module.

NOTE: The slot is keyed to ensure correct insertion of the SD vFlash card.

- 2 Press the SD vFlash card inward to lock it into the SD vFlash card slot.

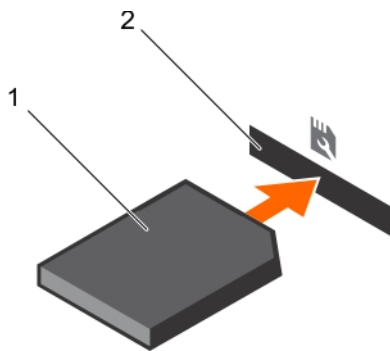

Figure 43. Installing an optional SD vFlash card

iDRAC port card (optional)

The iDRAC port card consists of a SD vFlash card slot and an iDRAC port. The iDRAC port card is used for advanced management of the system. An SD vFlash card is a Secure Digital (SD) card that plugs into the SD vFlash card slot in the system. It provides persistent on-demand local storage and a custom deployment environment that allows automation of server configuration, scripts, and imaging. It emulates USB device(s). For more information, see the Integrated Dell Remote Access Controller User's Guide at Dell.com/esmanuals.

The iDRAC port card consists of the SD vFlash card slot and an iDRAC port. The iDRAC port card features a dedicated NIC port and is used for remote, advanced management of the system through the network.

An SD vFlash card is a Secure Digital (SD) card that plugs into the SD vFlash card slot in the iDRAC port card. It provides persistent on-demand local storage and a custom deployment environment that enables automation of server configuration, scripts, and imaging. It emulates a USB device. For more information, see the Integrated Dell Remote Access Controller User's Guide at Dell.com/idracmanuals.

Removing the optional iDRAC port card

Prerequisites

CAUTION: 許多維修僅可由獲得認可的維修技術人員來完成。您只能依照產品說明文件中的授權說明或在線上或電話服務和支援團隊的指導下，執行故障排除和簡單的維修。由未經 **Dell** 授權的維修造成的損壞不在保固範圍之內。請閱讀並遵循產品隨附的安全說明。

- 1 Follow the safety guidelines listed in the Safety instructions section.
- 2 Follow the procedure listed in the Before working inside your system section.
- 3 Keep the Phillips #2 screwdriver ready.
- 4 If connected, disconnect the network cable from the iDRAC port card.

Steps

- 1 Loosen the screw securing the iDRAC port card holder to the system board.
- 2 Pull the iDRAC port card to disengage it from the iDRAC port card connector on the system board, and remove the card from the chassis.

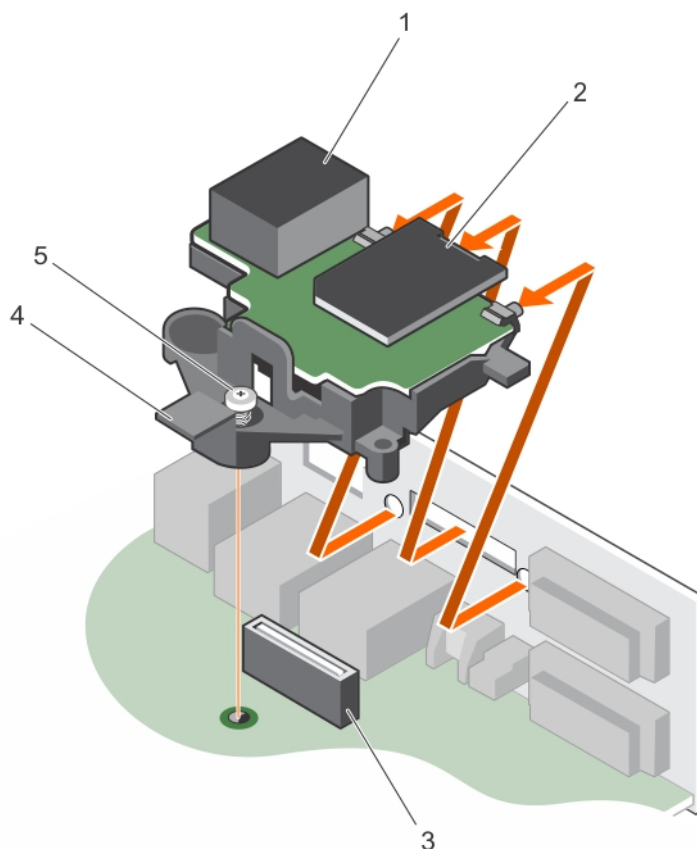

Figure 44. Removing the iDRAC port card

1 iDRAC port

2 SD vFlash media card slot

- 3 iDRAC port card connector
- 5 captive screw

- 4 iDRAC port card holder

Next steps

- 1 Install the iDRAC port card.
- 2 If disconnected, reconnect the network cable.
- 3 Follow the procedure listed in the After working inside your system section.

Related links

[Installing the optional iDRAC port card](#)

Installing the optional iDRAC port card

Prerequisites

⚠ CAUTION: 許多維修僅可由獲得認可的維修技術人員來完成。您只能依照產品說明文件中的授權說明或在線上或電話服務和支援團隊的指導下，執行故障排除和簡單的維修。由未經 **Dell** 授權的維修造成的損壞不在保固範圍之內。請閱讀並遵循產品隨附的安全說明。

- 1 Ensure that you follow the safety guidelines listed in the Safety instructions section.
- 2 Follow the procedure listed in the Before working inside your system section.
- 3 Keep the Phillips #2 screwdriver ready.

Steps

- 1 Align and insert the tabs on the iDRAC port card into the slots on the chassis.
- 2 Insert the iDRAC port card into the connector on the system board.
- 3 Tighten the screw that secures the iDRAC port card holder to the system board.

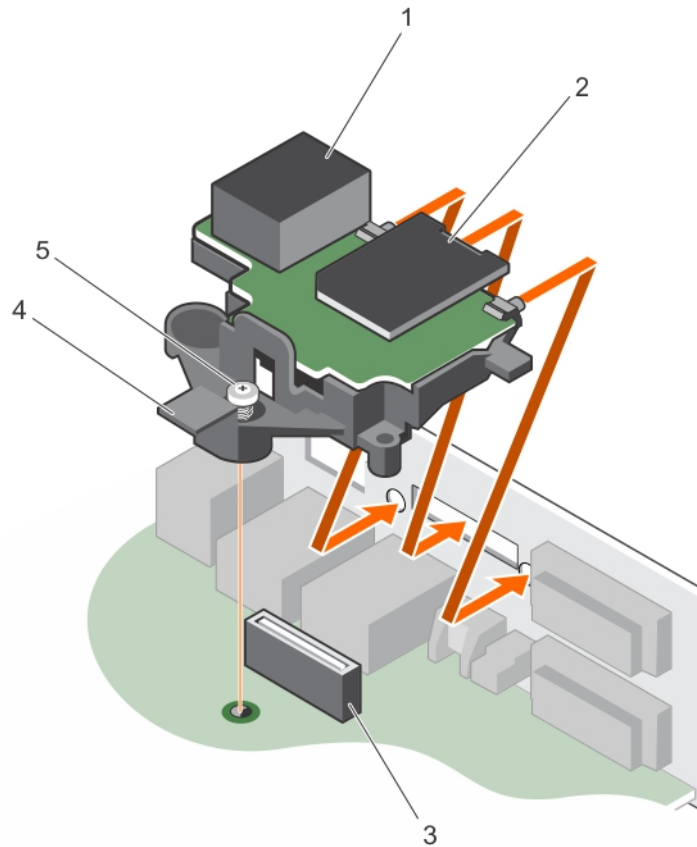

Figure 45. Installing the iDRAC port card

- | | | | |
|---|---------------------------|---|---------------------------|
| 1 | iDRAC port | 2 | SD vFlash media card slot |
| 3 | iDRAC port card connector | 4 | iDRAC port card board |
| 5 | screw | | |

Next steps

- 1 If disconnected, reconnect the network cable.
- 2 Follow the procedure listed in the After working inside your system section.

Processors and heat sinks

Use the following procedures when:

- Removing and installing a heat sink
- Installing an additional processor
- Replacing a processor

NOTE: To ensure proper cooling, you must install a processor blank in any empty processor socket.

Removing the heat sink

Prerequisites

⚠ CAUTION: 許多維修僅可由獲得認可的維修技術人員來完成。您只能依照產品說明文件中的授權說明或在線上或電話服務和支援團隊的指導下，執行故障排除和簡單的維修。由未經 **Dell** 授權的維修造成的損壞不在保固範圍之內。請閱讀並遵循產品隨附的安全說明。

⚠ CAUTION: 除非打算卸下處理器，否則請勿將散熱片從處理器上拆下。散熱器是維持正常散熱條件的必要零件。

ⓘ NOTE: This is a Field Replaceable Unit (FRU). Removal and installation procedures should be performed only by Dell certified service technicians.

- 1 Ensure that you follow the safety guidelines listed in the Safety instructions section.
- 2 Keep the Phillips #2 screwdriver ready.
- 3 Follow the procedure listed in the Before working inside your system section.
- 4 Disconnect the heat sink cooling fan power cable connector from the connector on the system board.

⚠ WARNING: 即使系統已關機經過一段時間，散熱器和處理器有時溫度仍可能很高，因此不該觸碰。請待散熱器和處理器冷卻後，再進行後續處理。

Steps

- 1 Loosen one of the screws that secure the heat sink to the system board.
Allow some time (around 30 seconds) for the heat sink to loosen from the processor.
- 2 Loosen the screw that is diagonally opposite the screw you first removed.
- 3 Repeat the procedure for the remaining two screws.
- 4 Lift the heat sink away from the system.

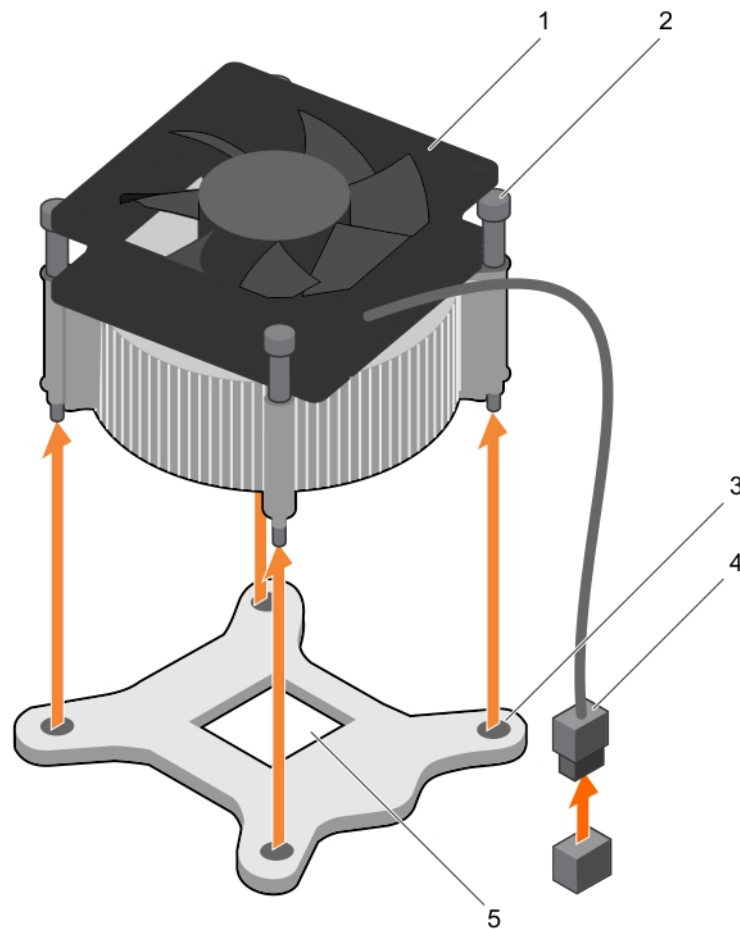

Figure 46. Removing and installing a heat sink

- | | | | |
|---|------------------|---|---|
| 1 | heat sink | 2 | captive screw (4) |
| 3 | slot (4) | 4 | heat sink cooling fan power cable connector |
| 5 | processor socket | | |

Next steps

- 1 If you are removing only a faulty heat sink, install the replacement heat sink, if not, remove the processor.
- 2 Follow the procedure listed in the After working inside your system section.

Related links

- [安裝散熱器](#)
- [Removing the processor](#)

Removing the processor

Prerequisites

- △ CAUTION:** 許多維修僅可由獲得認可的維修技術人員來完成。您只能依照產品說明文件中的授權說明或在線上或電話服務和支援團隊的指導下，執行故障排除和簡單的維修。由未經 **Dell** 授權的維修造成的損壞不在保固範圍之內。請閱讀並遵循產品隨附的安全說明。

NOTE: This is a Field Replaceable Unit (FRU). Removal and installation procedures should be performed only by Dell certified service technicians.

- 1 Follow the safety guidelines listed in the Safety instructions section.
- 2 If you are upgrading your system, download the latest system BIOS version from [Dell.com/support](https://www.dell.com/support) and follow the instructions included in the compressed download file to install the update on your system.

NOTE: You can update the system BIOS by using the Dell Lifecycle Controller.

- 3 Follow the procedure listed in the Before working inside your system section.
- 4 Remove the heat sink.
- 5 Keep the Phillips #2 screwdriver ready.

WARNING: The processor will be hot to touch for some time after the system has been powered down. Allow the processor to cool before removing it.

CAUTION: The processor is held in its socket under strong pressure. Be aware that the release lever can spring up suddenly if not firmly held.

Steps

- 1 Release the socket lever by pushing the lever down and out from under the tab on the processor shield.
- 2 Lift the lever upward until the processor shield lifts.

CAUTION: The processor socket pins are fragile and can be permanently damaged. Be careful not to bend the pins in the processor socket when removing the processor out of the socket.

- 3 Lift the processor out of the socket.

NOTE: After removing the processor, place it in an antistatic container for reuse, return, or temporary storage. Do not touch the bottom of the processor to avoid damage to the processor contacts. Touch only the side edges of the processor.

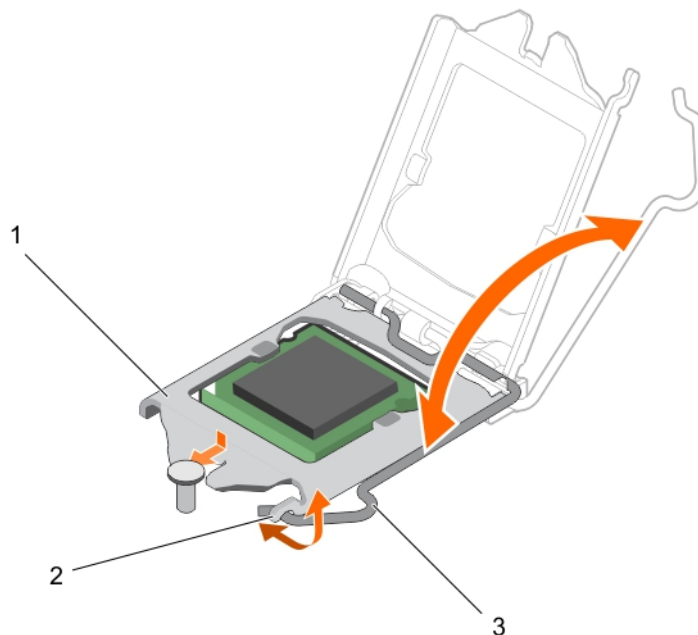

Figure 47. Opening and closing the processor shield

- 1 processor shield
- 3 socket lever

- 2 tab on the processor shield

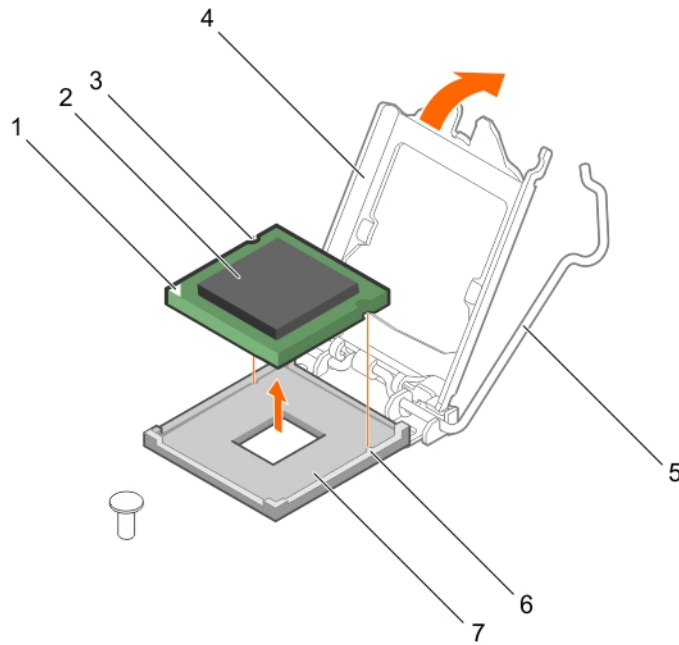

Figure 48. Removing and installing a processor

- | | | | |
|---|------------------------------|---|------------------|
| 1 | pin-1 indicator of processor | 2 | processor |
| 3 | slot (2) | 4 | processor shield |
| 5 | socket lever | 6 | socket keys (2) |
| 7 | socket | | |

Next steps

- 1 Install the processor.
- 2 Install the heat sink.
- 3 Follow the procedure listed in the After working inside your system section.

Related links

- [Removing the heat sink](#)
- [Installing the processor](#)

Installing the processor

Prerequisites

⚠ CAUTION: 許多維修僅可由獲得認可的維修技術人員來完成。您只能依照產品說明文件中的授權說明或在線上或電話服務和支援團隊的指導下，執行故障排除和簡單的維修。由未經 Dell 授權的維修造成的損壞不在保固範圍之內。請閱讀並遵循產品隨附的安全說明。

ⓘ NOTE: This is a Field Replaceable Unit (FRU). Removal and installation procedures should be performed only by Dell certified service technicians.

- 1 Ensure that you follow the [Safety instructions](#).
- 2 If you are upgrading your system, download the latest system BIOS version from Dell.com/support and follow the instructions included in the compressed download file to install the update on your system.

NOTE: You can update the system BIOS by using the Dell Lifecycle Controller.

- 3 Follow the procedure listed in [拆裝系統內部元件之前](#).
- 4 Remove the cooling shroud.

Steps

- 1 Unpack the new processor.

If the processor has previously been used in a system, remove any remaining thermal grease from the processor by using a lint free cloth.

- 2 Locate the processor socket.

CAUTION: While removing or reinstalling the processor, wipe your hands of any contaminants. Contaminants on the processor contacts such as thermal grease or oil can damage the processor.

- 3 Align the processor with the socket keys.

CAUTION: 請勿用力固定處理器，只要處理器的位置正確，即可輕易放入插槽。

CAUTION: 若處理器安裝位置不正確，可能使主機板或處理器永久損壞。請小心不要折彎插槽上的針腳。

- 4 Align the pin-1 indicator of the processor with the triangle on the socket.

- 5 Place the processor on the socket such that the slots on the processor align with the socket keys.

- 6 Close the processor shield by sliding it under the retention screw.

- 7 Lower the socket lever and push it under the tab to lock it.

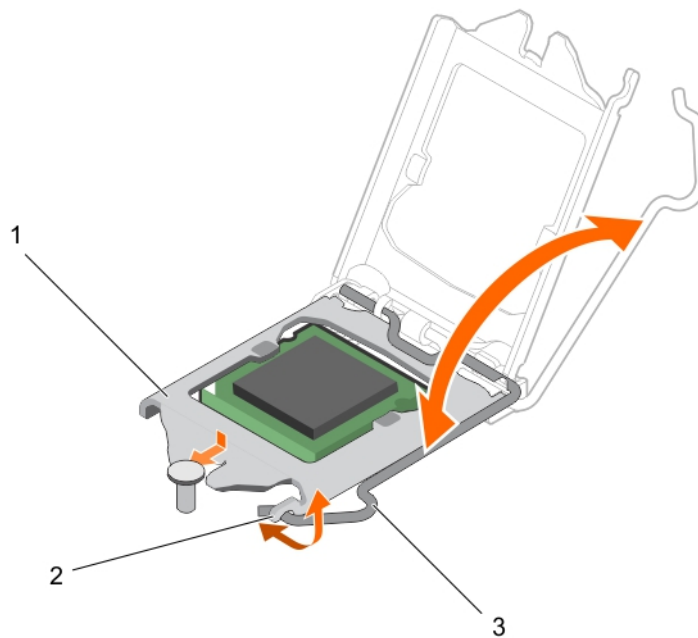

Figure 49. Opening and closing the processor shield

- | | | | |
|---|------------------|---|-----------------------------|
| 1 | processor shield | 2 | tab on the processor shield |
| 3 | socket lever | | |

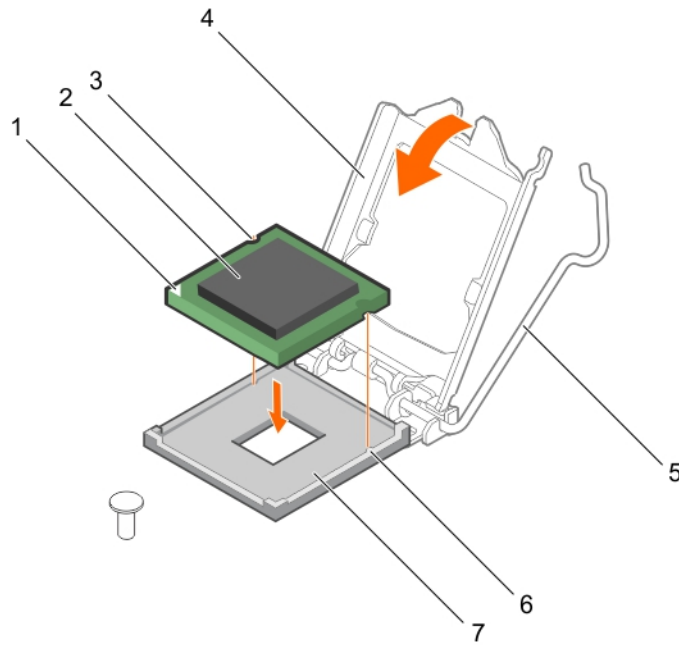

Figure 50. Installing a processor

- | | | | |
|---|------------------------------|---|------------------|
| 1 | pin-1 indicator of processor | 2 | processor |
| 3 | slot (2) | 4 | processor shield |
| 5 | socket lever | 6 | socket keys (2) |
| 7 | socket | | |

Next steps

NOTE: Ensure that you install the heat sink after you install the processor. The heat sink is necessary to maintain proper thermal conditions.

- 1 Install the heat sink.
- 2 Follow the procedure listed in [拆裝系統內部元件之後](#).
- 3 While booting, press F2 to enter System Setup and check that the processor information matches the new system configuration.
- 4 Run the system diagnostics to verify that the new processor operates correctly.

Related links

[安裝散熱器](#)

安裝散熱器

警告: 許多維修僅可由獲得認可的維修技術人員來完成。您只能依照產品說明文件中的授權說明或在線上或電話服務和支援團隊的指導下，執行故障排除和簡單的維修。由未經 **Dell** 授權的維修造成的損壞不在保固範圍之內。請閱讀並遵循產品隨附的安全說明。

註: 這是現場可更換單元 (FRU)。只能由 **Dell** 認可的維修技術人員執行拆卸和安裝程序。

- 1 請確定您遵循[安全說明](#)。
- 2 準備 Phillips 2 號螺絲起子。

- 3 按照中的程序進行操作。[拆裝系統內部元件之前](#)。
- 4 安裝處理器。

步驟

- 1 如果您要使用現有的散熱片，使用乾淨的無纖維布擦掉散熱片上的散熱膏。
- 2 使用處理器套件包含的散熱膏注射器，以在處理器上方的細長螺紋注射散熱膏，如下圖所示。

△ 警告：塗抹過多的散熱膏可能使散熱膏流出，接觸或污染處理器插槽。

ⓘ 註：散熱膏僅供一次性使用。在使用注射器後，請將它丟棄。



圖 51. 在處理器頂部塗上散熱膏

- | | |
|----------|-------|
| 1 處理器 | 2 散熱膏 |
| 3 散熱膏注射器 | |

- 3 將散熱器置於處理器上。
- 4 鎖緊四顆將散熱器固定在主機板上的螺絲中的其中一顆。
- 5 鎖緊與您鎖緊的第一顆螺絲處於對角的螺絲。

ⓘ 註：在安裝散熱器時，請勿將散熱器固定螺絲鎖得過緊。要避免鎖附過緊，鎖緊固定螺絲直到感覺到阻礙。螺絲張力不得超過 **6 in-lb (6.9 kg-cm)**。

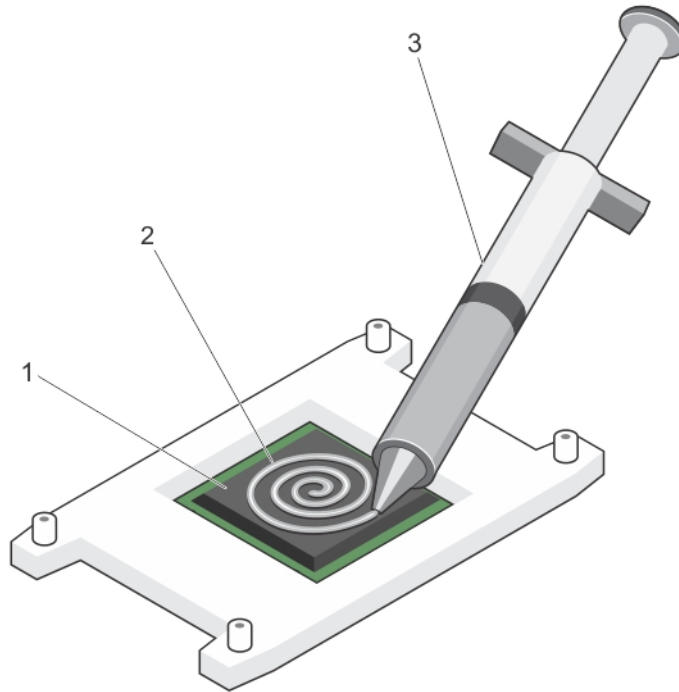
- 6 對剩下的兩顆螺絲重複此程序。

- 1 按照中的程序進行操作。[拆裝系統內部元件之後](#)。
- 2 在啟動期間，按下 F2 以進入 System Setup (系統設定)，然後檢查處理器資訊與新的系統組態是否相符。
- 3 執行系統診斷程式，以確認新的處理器能夠正常運作。

電源供應器

您的系統支援 290 W AC 電源供應器裝置。

Removing the power supply unit (PSU)

Prerequisites

△ CAUTION: 許多維修僅可由獲得認可的維修技術人員來完成。您只能依照產品說明文件中的授權說明或在線上或電話服務和支援團隊的指導下，執行故障排除和簡單的維修。由未經 **Dell** 授權的維修造成的損壞不在保固範圍之內。請閱讀並遵循產品隨附的安全說明。

- 1 Ensure that you follow the [Safety instructions](#).
- 2 Follow the procedure listed in [拆裝系統內部元件之前](#).
- 3 Keep the Phillips #2 screwdriver ready.

Steps

- 1 Disconnect all the power cables from the PSU to the system board.
- 2 Remove the screws securing the PSU to the chassis.
- 3 Press the release tab beside the PSU, and slide the PSU toward the front of the system.
- 4 Lift the PSU out of the chassis.

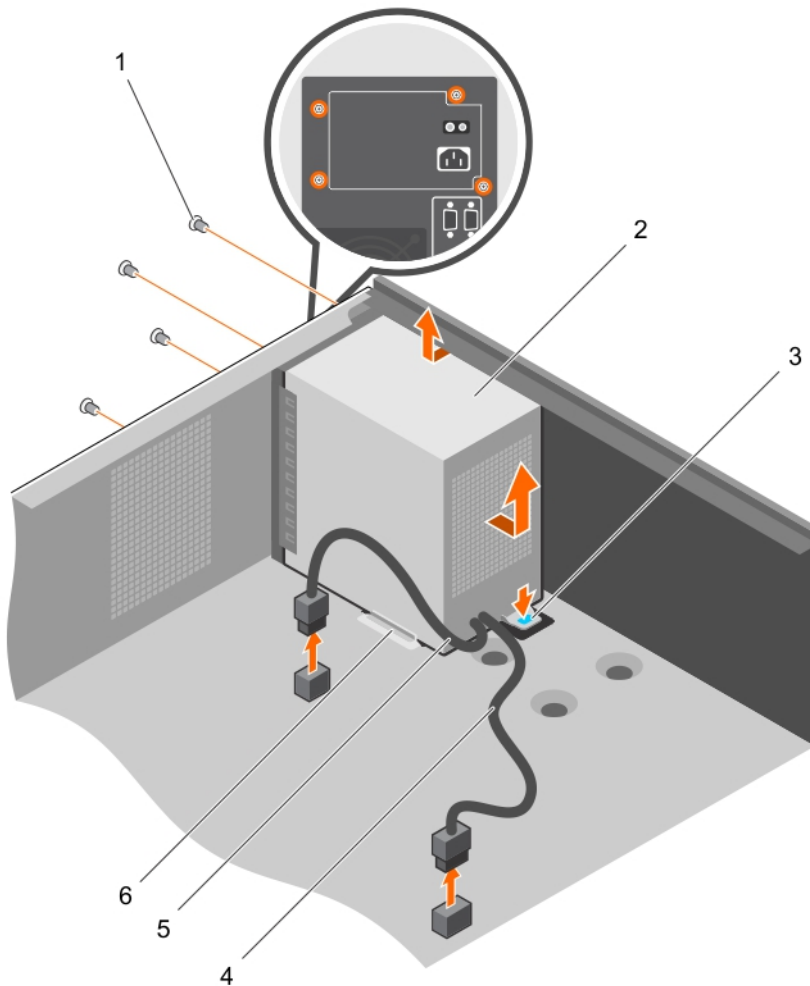

Figure 52. Removing the PSU

- | | | | |
|---|----------------|---|-------------------|
| 1 | screws (4) | 2 | PSU |
| 3 | release tab | 4 | P1 power cable |
| 5 | P2 power cable | 6 | PSU support guide |

Next steps

- 1 Install the PSU.
- 2 Follow the procedure listed in [拆裝系統內部元件之後](#).

Related links

[Installing the power supply unit \(PSU\)](#)

Installing the power supply unit (PSU)

Prerequisites

CAUTION: 許多維修僅可由獲得認可的維修技術人員來完成。您只能依照產品說明文件中的授權說明或在線上或電話服務和支援團隊的指導下，執行故障排除和簡單的維修。由未經 **Dell** 授權的維修造成的損壞不在保固範圍之內。請閱讀並遵循產品隨附的安全說明。

- 1 Ensure that you follow the [Safety instructions](#).
- 2 Follow the procedure listed in [拆裝系統內部元件之前](#).
- 3 Keep the Phillips #2 screwdriver ready.

Steps

- 1 Place the PSU in the chassis and slide it toward the back of the chassis.
- 2 To secure the PSU to the chassis, insert and tighten the screws on the back of the chassis.
- 3 Connect the power cables to the system board connectors.

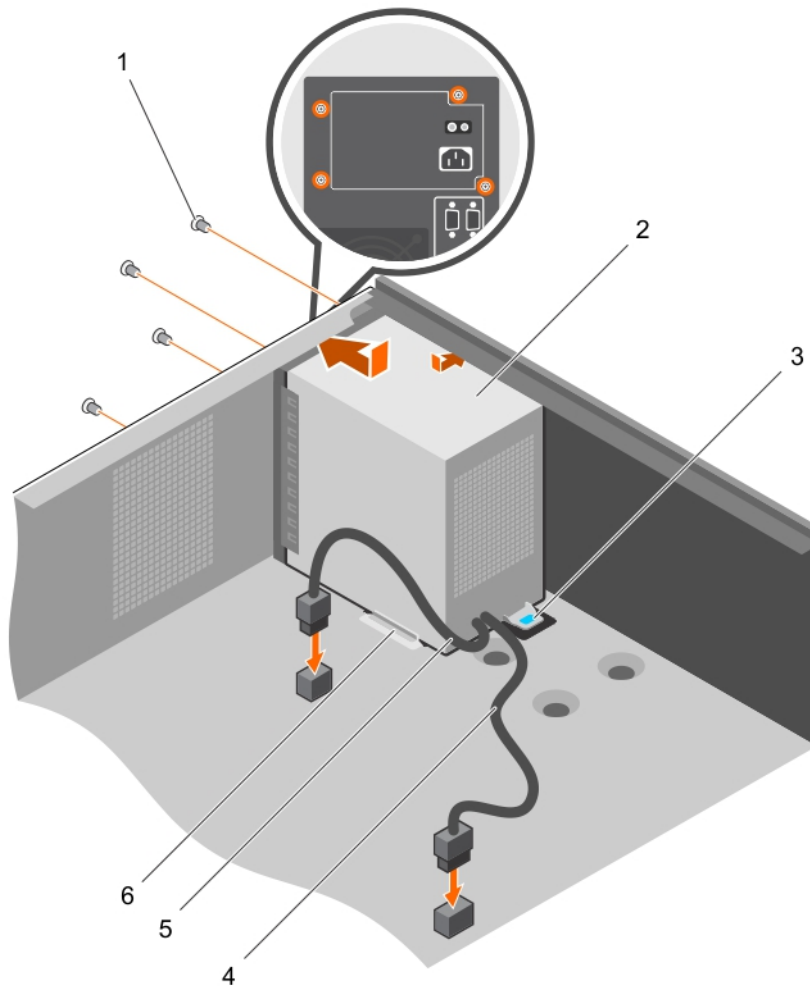

Figure 53. Installing the PSU

- | | | | |
|---|----------------|---|-------------------|
| 1 | screws (4) | 2 | PSU |
| 3 | release tab | 4 | P1 power cable |
| 5 | P2 power cable | 6 | PSU support guide |

Next step

Follow the procedure listed in [拆裝系統內部元件之後](#).

System battery

The system battery is used to power the real-time clock and storing the BIOS settings of the 系統.

Replacing the system battery

Prerequisites

- 1 Follow the safety guidelines listed in safety instructions section.
- 2 Follow the procedure listed in the Before working in your system section.
- 3 Keep the plastic scribe ready.

⚠ WARNING: 如果新電池安裝不正確，可能會有爆炸的危險。請僅以相同或由製造廠商建議的同類型電池來更換原有的電池。有關更多資訊，請參閱系統隨附的安全資訊。

⚠ CAUTION: 許多維修僅可由獲得認可的維修技術人員來完成。您只能依照產品說明文件中的授權說明或在線上或電話服務和支援團隊的指導下，執行故障排除和簡單的維修。由未經 Dell 授權的維修造成的損壞不在保固範圍之內。請閱讀並遵循產品隨附的安全說明。

ⓘ NOTE: This is a Field Replaceable Unit (FRU). Removal and installation procedures must be performed only by Dell certified service technicians.

Steps

- 1 Locate the battery socket. For more information, see the System board connectors section.

⚠ CAUTION: 為避免損壞電池連接器，安裝或卸下電池時，必須穩固地固定連接器。

- 2 Use a plastic scribe to pry out the system battery as shown in the following illustration:

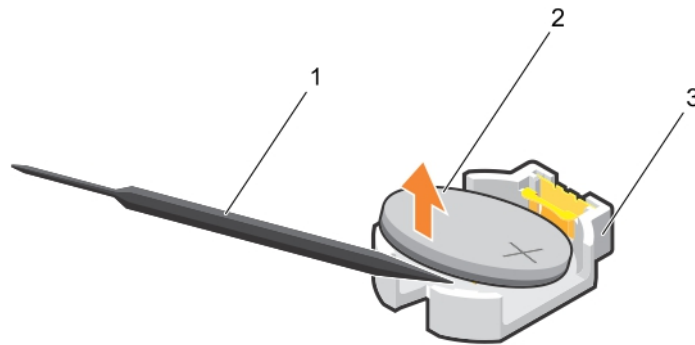

Figure 54. Removing the system battery

- 1 plastic scribe
 - 2 positive side of the battery connector
 - 3 securing tabs
- 3 Install a new system battery by holding the battery with the "+" sign facing up and slide it under the securing tabs.
 - 4 Press the battery into the connector until it snaps into place.

- c heat sink and processor
- d iDRAC port card, if installed

Steps

- 1 Disconnect all cables from the system board.

CAUTION: Take care not to damage the system identification button while removing the system board from the chassis.

- 2 Remove the screws on the system board, and slide the system board toward the front of the chassis.

- 3 Hold the system board by the touch points and lift it out of the chassis.

CAUTION: To prevent damage to the system board, do not lift the system board by holding a memory module, processor, or other components; hold the system board by its edges only.

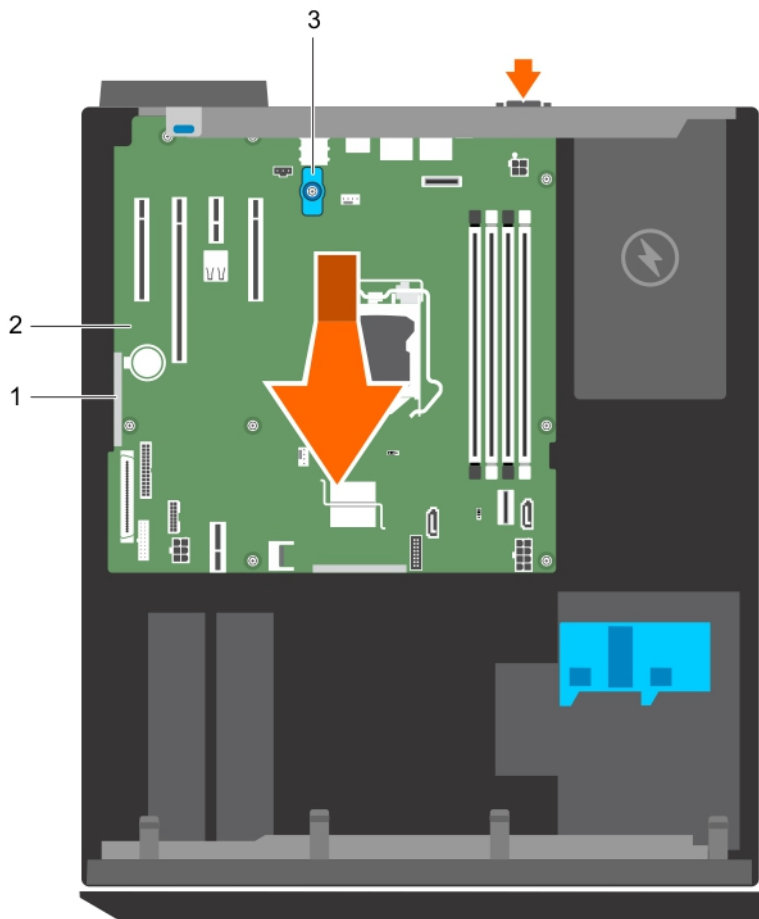

Figure 56. Removing the system board

- 1 touch point (2)
- 2 system board
- 3 system board t-handle post

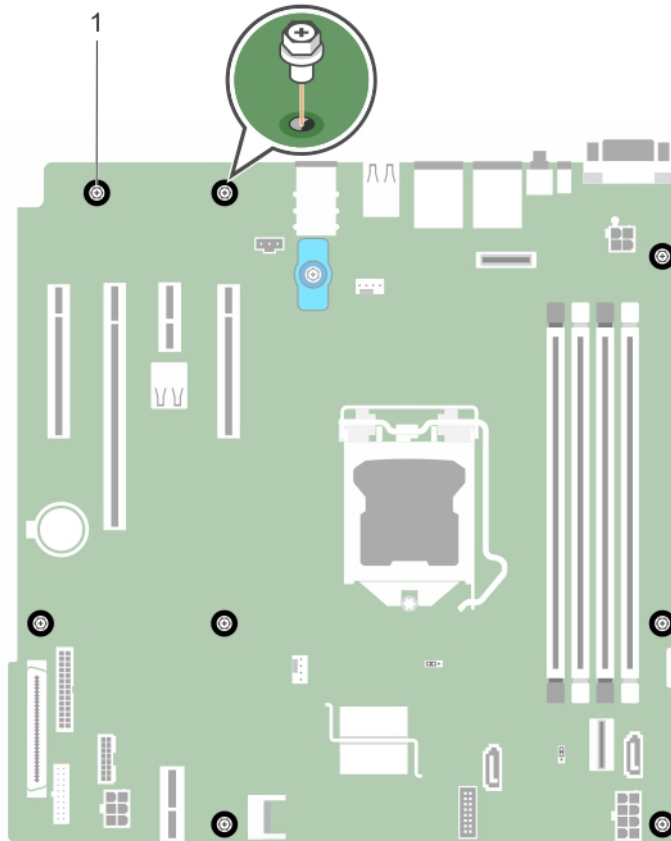

Figure 57. Removing the screws on the system board

- 1 screw (8)

Next steps

- 1 Install the system board.
- 2 Follow the procedure listed in the After working inside your system section.

Related links

- [卸下記憶體模組](#)
- [Removing an expansion card](#)
- [Removing the heat sink](#)
- [Removing the processor](#)
- [Removing the optional iDRAC port card](#)

Installing the system board

Prerequisites

- △ CAUTION:** 許多維修僅可由獲得認可的維修技術人員來完成。您只能依照產品說明文件中的授權說明或在線上或電話服務和支援團隊的指導下，執行故障排除和簡單的維修。由未經 Dell 授權的維修造成的損壞不在保固範圍之內。請閱讀並遵循產品隨附的安全說明。

NOTE: This is a Field Replaceable Unit (FRU). Removal and installation procedures must be performed only by Dell certified service technicians.

CAUTION: 要拿起主機板時，請勿握住記憶體模組、處理器或其他元件。

CAUTION: Take care not to damage the system identification button while placing the system board into the chassis.

- 1 Follow the safety guidelines listed in Safety instructions section.
- 2 Follow the procedure listed in the Before working inside your system section.
- 3 Keep the Phillips #2 screwdriver ready.

Steps

- 1 Hold the system board by its edges, and orient it toward the back of the chassis.
- 2 Lower the system board into the chassis until the connectors at the back of the system board align with the slots on the back of the chassis.
- 3 Tighten the screws that secure the system board to the chassis.

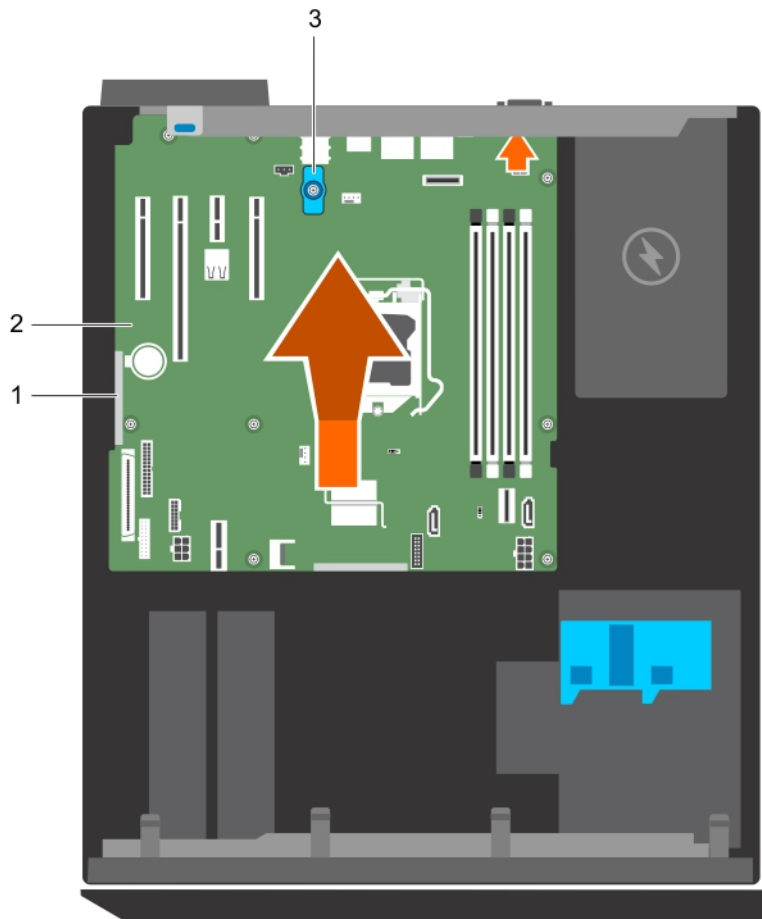

Figure 58. Install the system board

- | | |
|------------------------------|----------------|
| 1 touch point (2) | 2 system board |
| 3 system board t-handle post | |

Next steps

- 1 If required, install the Trusted Platform Module (TPM). See, the Installing the Trusted Platform Module section.

- 2 Reinstall the following components:
 - a memory modules
 - b heat sink and processor
 - c iDRAC port card, if removed
- 3 Reconnect all cables to the system board.

NOTE: Ensure that the cables inside the system are routed through the cable routing latch.
- 4 Follow the procedure listed in the After working inside your system section.
- 5 Import your new or existing iDRAC Enterprise license. For more information, see the Integrated Dell Remote Access Controller User's Guide, at Dell.com/idracmanuals.
- 6 Ensure that you perform the following steps:
 - a If the service tag is not backed up in the backup flash device, enter the system service tag manually. See the Entering the system service tag by using System Setup section.
 - b Update the BIOS and iDRAC versions.
 - c Re-enable the Trusted Platform Module (TPM). See the Re-enabling the TPM for BitLocker users section.

Related links

[安裝記憶體模組](#)

[Installing the processor](#)

[安裝散熱器](#)

[Installing the optional iDRAC port card](#)

使用系統設定輸入系統服務標籤

- 1 開啟系統。
- 2 按 F2 進入 System Setup (系統設定)。
- 3 按一下 **Service Tag Settings (服務標籤設定)**。
- 4 輸入服務標籤。

註: 只有在 **Service Tag (服務標籤)** 欄位空白時，才可以輸入服務標籤。請務必輸入正確的服務標籤。一旦輸入服務標籤，即無法更新或變更。
- 5 按一下**確定**。
- 6 匯入您的全新或現有的 iDRAC Enterprise 授權。

如需更多資訊，請參閱 *Integrated Dell Remote Access Controller 使用指南*，網址是：Dell.com/idracmanuals。

Trusted Platform Module

Trusted Platform Module (TPM) is a dedicated microprocessor designed to secure hardware by integrating cryptographic keys into devices. A software can use a Trusted Platform Module to authenticate hardware devices. As each TPM chip has a unique and secret RSA key burned in as it is produced, it can perform the platform authentication.

CAUTION: 請勿嘗試從主機板卸下可信賴平台模組 (TPM)。安裝 TPM 後，此模組便會透過密碼編譯繫結至該特定主機板。任何嘗試卸下已安裝 TPM 的動作都會導致密碼編譯繫結中斷，而無法重新安裝或再安裝到其他主機板上。

NOTE: This is a Field Replaceable Unit (FRU). Removal and installation procedures must be performed only by Dell certified service technicians.

Installing the Trusted Platform Module

Prerequisites

CAUTION: 許多維修僅可由獲得認可的維修技術人員來完成。您只能依照產品說明文件中的授權說明或在線上或電話服務和支援團隊的指導下，執行故障排除和簡單的維修。由未經 Dell 授權的維修造成的損壞不在保固範圍之內。請閱讀並遵循產品隨附的安全說明。

NOTE: This is a Field Replaceable Unit (FRU). Removal and installation procedures should be performed only by Dell certified service technicians.

- 1 Follow the safety guidelines listed in the Safety instructions section.
- 2 Follow the procedure listed in the Before working inside your 系統 section.

Steps

- 1 Locate the TPM connector on the system board.

NOTE: To locate the TPM connector on the system board, see the System board connectors section.

- 2 Align the edge connectors on the TPM with the slot on the TPM connector.
- 3 Insert the TPM into the TPM connector such that the plastic rivet aligns with the slot on the system board.
- 4 Press the plastic rivet until the rivet snaps into place.

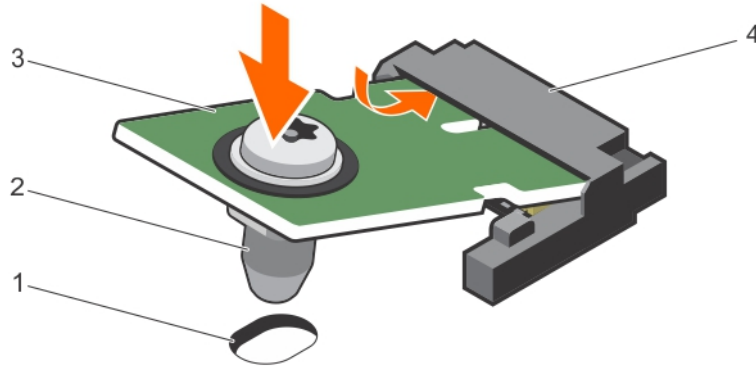

Figure 59. Installing the TPM

- | | |
|----------------------------------|-----------------|
| 1 rivet slot on the system board | 2 plastic rivet |
| 3 TPM | 4 TPM connector |

Next steps

- 1 Install the system board.
- 2 Follow the procedure listed in the After working inside your 系統 section.

Initializing the TPM for BitLocker users

Initialize the TPM.

For more information about initializing the TPM, see <http://technet.microsoft.com/en-us/library/cc753140.aspx>.

The **TPM Status** changes to **Enabled, Activated**.

Initializing the TPM for TXT users

- 1 While booting your 系統, press F2 to enter System Setup.
- 2 On the **System Setup Main Menu** screen, click **System BIOS > System Security Settings**.
- 3 From the **TPM Security** option, select **On with Pre-boot Measurements**.
- 4 From the **TPM Command** option, select **Activate**.
- 5 Save the settings.
- 6 Restart your 系統.
- 7 Enter **System Setup** again.
- 8 On the **System Setup Main Menu** screen, click **System BIOS > System Security Settings**.
- 9 From the **Intel TXT** option, select **On**.

Using system diagnostics

If you experience a problem with your 系統, run the system diagnostics before contacting Dell for technical assistance. The purpose of running system diagnostics is to test your 系統 hardware without using additional equipment or risking data loss. If you are unable to fix the problem yourself, service and support personnel can use the diagnostics results to help you solve the problem.

Dell Embedded System Diagnostics

① | **NOTE: The Dell Embedded System Diagnostics is also known as Enhanced Pre-boot System Assessment (ePSA) diagnostics.**

The Embedded System Diagnostics provides a set of options for particular device groups or devices allowing you to:

- Run tests automatically or in an interactive mode
- Repeat tests
- Display or save test results
- Run thorough tests to introduce additional test options to provide extra information about the failed device(s)
- View status messages that inform you if tests are completed successfully
- View error messages that inform you of problems encountered during testing

When to use the Embedded System Diagnostics

Run the Embedded System Diagnostics (ePSA) if your system does not boot.

Running the Embedded System Diagnostics from Boot Manager

Prerequisite

Run the Embedded System Diagnostics (ePSA) if your 系統 does not boot.

Steps

- 1 When the 系統 is booting, press F10.
- 2 Use the up arrow and down arrow keys to select **System Utilities > Launch Diagnostics**.
The **ePSA Pre-boot System Assessment** window is displayed, listing all devices detected in the 系統. The diagnostics starts executing the tests on all the detected devices.

Running the Embedded System Diagnostics from the Dell Lifecycle Controller

- 1 As the 系統 boots, press F10.
- 2 Select **Hardware Diagnostics** → **Run Hardware Diagnostics**.

The **ePSA Pre-boot System Assessment** window is displayed, listing all devices detected in the 系統. The diagnostics starts executing the tests on all the detected devices.

系統診斷程式控制

功能表	說明
Configuration	顯示所有偵測到的裝置的組態和狀態資訊。
Results	顯示所有已執行的測試結果。
System health	提供目前的系統效能概觀。
Event log	顯示在系統上執行的所有測試結果時間戳記。如果至少已記錄一個事件，則會顯示此事件記錄。

跳線與連接器

主題：

- 主機板跳線和連接器
- System board jumper settings
- 停用忘記的密碼

主機板跳線和連接器



圖 60. 主機板跳線和連接器

表 19. 主機板跳線和連接器



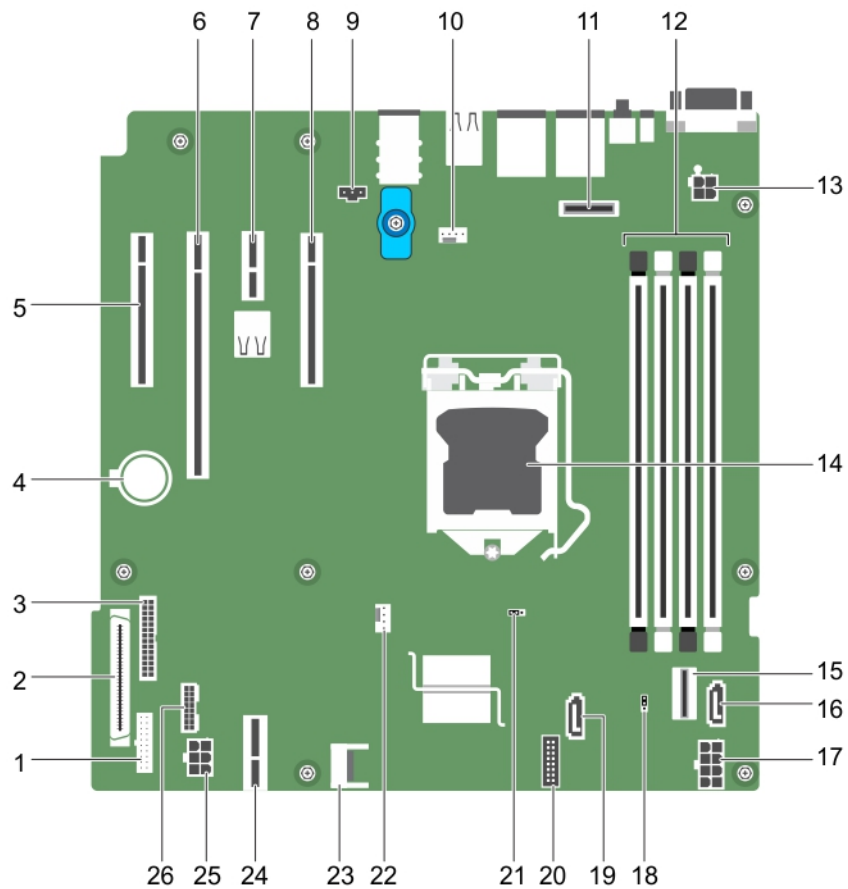

項目	連接器	說明
1	FP_USB	前面板 USB 連接器
2	CTRL_PNL	控制面板
3	PIB_CONN	PIB 連接器
4	電池	系統電池
5	插槽 1 PCIE_G3_X4 CPU	PCIe 卡連接器 1
6	插槽 2 PCIE_G3_X8 CPU	PCIe 卡連接器 2
7	插槽 3 PCIE_G3_X1 CPU	PCIe 卡連接器 3
8	插槽 4 PCIE_G3_X4 CPU	PCIe 卡連接器 4
9	J_INTRU2	侵入連接器
10	MB / 風扇 1	散熱風扇連接器
11	J_AMEA1	iDRAC 連接埠卡連接器
12	A1、A2、A3、A4	記憶體模組插槽
13	CPU_PWR	CPU 電源連接器 P2
14	CPU	處理器插槽
15	SATA 0–3/SATAe	Mini SAS 連接器
16	SATA_ODD/SSD	光學磁碟機連接器
17	SYS_PWR	系統電源連接器 P1
18	PWRD_EN	密碼跳線
19	J_SATA_2	SATA 連接器 (2)
20	CTRL_PNL	控制面板連接器
21	NVRAM_CLR	NVRAM 密碼跳線
22	CPU_FAN	CPU 風扇連接器
23	TPM	可信賴平台模組連接器
24	IDSMD	內部雙 SD 模組連接器
25	HDD/ODD_PWR	硬碟電源連接器
26	BP_SIG	背板訊號連接器

System board jumper settings

⚠ CAUTION: Many repairs may only be done by a certified service technician. You should only perform troubleshooting and simple repairs as authorized in your product documentation, or as directed by the online or telephone service and support team. Damage due to servicing that is not authorized by Dell is not covered by your warranty. Read and follow the safety instructions that came with the product.

For information about resetting the password jumper to disable a password, see the Disabling A Forgotten Password section.

Table 20. System Board Jumper settings

Jumper	Setting	Description
PWRD_EN	 1 2 3 (default)	The password feature is enabled (pins 1–2).
	 1 2 3	The password feature is disabled (pins 2–3).
NVRAM_CLR	 1 2 3 (default)	The configuration settings are retained at system boot (pins 2–3).
	 1 2 3	The configuration settings are cleared at the next system boot. (pins 1–2).

停用忘記的密碼

系統的軟體安全性功能包括系統密碼與設定密碼。密碼跳線會停用目前使用中的任何密碼。PASSWORD 跳線可啟用或停用這些密碼功能並清除目前使用中的密碼。

事前準備作業

警告: 許多維修僅可由獲得認可的維修技術人員來完成。您只能依照產品說明文件中的授權說明或在線上或電話服務和支援團隊的指導下，執行故障排除和簡單的維修。由未經 **Dell** 授權的維修造成的損壞不在保固範圍之內。請閱讀並遵循產品隨附的安全說明。

步驟

- 1 關閉系統，包括任何連接的周邊裝置，然後從電源插座拔下系統電源線。
- 2 卸下系統機箱蓋。
- 3 將主機板上的跳線從插腳 2 和 3 移至插腳 1 和 2。
- 4 安裝系統機箱蓋。
必須等到跳線在插腳 1 和 2 之下重新啟動系統後，才會停用（清除）現有的密碼。但是您必須將跳線移回插腳 2 和 3，才能指定新的系統及 / 或設定密碼。

註: 如果您在跳線在插腳 1 和 2 之下指定新的系統及 / 或設定密碼，在下次電腦開機時，系統將會停用新密碼。

- 5 將系統重新接上電源插座，然後啟動系統以及所有連接的周邊裝置。
- 6 關閉系統，包括任何連接的周邊裝置，然後從電源插座拔下系統電源線。
- 7 卸下系統機箱蓋。
- 8 將主機板上的跳線從插腳 1 和 2 移至插腳 2 和 3。
- 9 安裝系統機箱蓋。
- 10 將系統重新接上電源插座，然後啟動系統以及所有連接的周邊裝置。
- 11 指定新的系統密碼及 / 或設定密碼。

故障排除您的系統

人身及系統安全至上

警告: 許多維修僅可由獲得認可的維修技術人員來完成。您只能依照產品說明文件中的授權說明或在線上或電話服務和支援團隊的指導下，執行故障排除和簡單的維修。由未經 **Dell** 授權的維修造成的損壞不在保固範圍之內。請閱讀並遵循產品隨附的安全說明。

註: 解決方案驗證是以出廠隨附的硬體組態執行。

主題：

- 故障排除 系統 啟動故障
- 故障排除外部連線
- 故障排除影像子系統
- 故障排除 USB 裝置
- 故障排除序列輸入和輸出裝置
- 故障排除 NIC
- 故障排除受潮的系統
- 故障排除受損的系統
- 故障排除系統電池
- 故障排除電源供應器
- 故障排除散熱問題
- 故障排除散熱風扇
- 故障排除系統記憶體
- 故障排除內部 USB 鑰匙
- 故障排除 Micro SD 卡
- 故障排除光碟機
- 故障排除磁碟機 或 SSD
- 故障排除儲存控制器
- 故障排除擴充卡
- 故障排除處理器
- 系統訊息

故障排除 系統 啟動故障

從 UEFI Boot Manager 安裝作業系統之後，如果您啟動系統，使系統進入 BIOS 啟動模式時，系統卻停止回應。若要避免此問題，您必須以和安裝作業系統時相同的啟動模式啟動系統。

針對所有其他的啟動問題，請記下出現在畫面中的系統訊息。

故障排除外部連線

在進行任何外接式裝置的故障排除之前，請先確定所有外接式纜線都已穩固連接到您的系統上的外接式連接器。

故障排除影像子系統

事前準備作業

① 註：請確定已在 iDRAC 圖形使用者介面 (GUI) 的 **Virtual Console (虛擬主控台)** 下方選取 **Local Server Video Enabled (啟用本機伺服器視訊)** 選項。如未選取此選項，本機視訊便將停用。

步驟

- 1 檢查監視器的纜線連接 (電源及顯示器)。
- 2 檢查從系統接到顯示器的影像介面纜線連接。
- 3 執行適當的診斷測試。

如果測試成功執行，則問題與視訊硬體無關。

後續步驟

如果測試失敗，請參閱「取得說明」一節。

故障排除 USB 裝置

事前準備作業

① 註：請按照步驟 1 至 5 來進行 USB 鍵盤或滑鼠的故障排除。在其他 USB 裝置方面，請至步驟 6。

步驟

- 1 從系統拔下鍵盤和 / 或滑鼠纜線，然後再重新連接。
- 2 如果問題仍然存在，將鍵盤和 / 或滑鼠連接至系統上的另一個 USB 連接埠。
- 3 如果問題已解決，請重新啟動系統，進入 System Setup (系統設定)，並檢查無功能的 USB 連接埠是否已啟用。
- 4 在 **IDRAC Settings Utility (IDRAC 設定公用程式)** 中，確定 **USB Management Port Mode (USB 管理連接埠模式)** 已設定為 **Automatic (自動)** 或 **Standard OS Use (標準作業系統使用)**。
- 5 如果問題還是沒有解決，以已知可正常運作的鍵盤或滑鼠替換鍵盤和 / 或滑鼠。
如果問題未解決，請繼續執行步驟 6，替系統連接的其他 USB 裝置排除故障。
如果問題未解決，請繼續執行連接到系統的其他 USB 裝置的故障排除。
- 6 關閉所有連接的 USB 裝置，然後從系統拔下其連線。
- 7 重新啟動系統。
- 8 如果您的鍵盤功能正常，請進入 System Setup (系統設定)，確認所有 USB 連接埠在 **Integrated Devices (整合裝置)** 畫面上啟用。
如果您的鍵盤無法正常運作，請使用遠端存取，以啟用或停用 USB 選項。
- 9 如果無法存取系統，請重設系統內部的 NVRAM_CLR 跳線，然後將 BIOS 還原為預設設定。請參閱「主機板跳線設定」一節
- 10 在 **IDRAC Settings Utility (IDRAC 設定公用程式)** 中，確定 **USB Management Port Mode (USB 管理連接埠模式)** 已設定為 **Automatic (自動)** 或 **Standard OS Use (標準作業系統使用)**。
- 11 逐一重新連接並啟動 USB 裝置。
- 12 如果某個 USB 裝置造成相同的問題，請關閉裝置，將 USB 纜線更換成已知功能正常纜線，然後啟動裝置。

後續步驟

如果故障排除失敗，請參閱「取得說明」一節。

故障排除序列輸入和輸出裝置

事前準備作業

步驟

- 1 關閉系統和連接到序列埠的任何周邊裝置。
- 2 將序列介面纜線替換成正常的作業纜線，然後啟動系統和 I/O 序列裝置。
如果問題已解決，請將介面纜線更換為正常的作業纜線。
- 3 關閉系統和 I/O 序列裝置，並將序列裝置替換為相容的裝置。
- 4 啟動系統和 I/O 序列裝置。

後續步驟

如果無法解決問題，請參閱「取得說明」一節。

故障排除 NIC

步驟

- 1 執行適當的診斷測試。如需更多資訊，請參閱「使用系統診斷」一節，瞭解有哪些診斷測試可用。
- 2 重新啟動系統，並檢查與 NIC 控制器有關的任何系統訊息。
- 3 檢查 NIC 控制器上適當的指示燈。
 - 如果連結指示燈未亮起，則纜線連接可能鬆脫。
 - 如果活動指示燈未亮起，表示網路驅動程式檔案可能損壞或遺失。
如有必要，請安裝或更換驅動程式。如需詳細資訊，請參閱 NIC 說明文件。
 - 嘗試使用另一已知良好的網路纜線。
 - 如果問題仍然存在，請使用交換器或集線器上的其他連接器。
- 4 確定已安裝適當的驅動程式，且已繫結通訊協定。如需詳細資訊，請參閱 NIC 說明文件。
- 5 進入 System Setup (系統設定)，並在 **Integrated Devices (整合裝置)** 畫面上確認已啟用 NIC 連接埠。
- 6 確定網路上的 NIC、集線器和交換器全都設定為相同的資料傳輸速度和雙工。如需詳細資訊，請參閱各個網路裝置的說明文件。
- 7 確定網路上的 NIC 和交換器全都設定為相同的資料傳輸速度和雙工。如需詳細資訊，請參閱各個網路裝置的說明文件。
- 8 確定所有網路纜線都是正確的類型，且未超過最大長度。

後續步驟

如果無法解決問題，請參閱「取得說明」一節。

故障排除受潮的系統

事前準備作業

△ 警告：許多維修僅可由獲得認可的維修技術人員來完成。您只能依照產品說明文件中的授權說明或在線上或電話服務和支援團隊的指導下，執行故障排除和簡單的維修。由未經 **Dell** 授權的維修造成的損壞不在保固範圍之內。請閱讀並遵循產品隨附的安全說明。

步驟

- 1 關閉系統和連接的周邊裝置，然後從電源插座上拔下電源線。
- 2 卸下系統機箱蓋。
- 3 從系統卸下以下元件 (如果已安裝)：
 - 電源供應器
 - 光碟機

- 硬碟機
 - 硬碟背板
 - USB 記憶體鑰匙
 - 硬碟托架
 - 散熱護罩
 - 擴充卡提升板 (如果已安裝)
 - 擴充卡
 - 散熱風扇組件 (如果已安裝)
 - 散熱風扇
 - 記憶體模組
 - 處理器和散熱器
 - 主機板
- 4 讓系統徹底晾乾至少 24 小時。
 - 5 除擴充卡外，重新安裝您在步驟 3 中移除的元件。
 - 6 安裝系統機箱蓋。
 - 7 開啟系統和連接的周邊裝置。
如果無法解決問題，請參閱「取得說明」一節。
 - 8 如果系統正確啟動，請將系統關閉，並且重新安裝您已移除的所有擴充卡。
 - 9 執行適當的診斷測試。如需詳細資訊，請參閱「使用系統診斷」一節。

後續步驟

如果測試失敗，請參閱「取得說明」一節。

故障排除受損的系統

事前準備作業

△ 警告：許多維修僅可由獲得認可的維修技術人員來完成。您只能依照產品說明文件中的授權說明或在線上或電話服務和支援團隊的指導下，執行故障排除和簡單的維修。由未經 **Dell** 授權的維修造成的損壞不在保固範圍之內。請閱讀並遵循產品隨附的安全說明。

步驟

- 1 關閉系統和連接的周邊裝置，然後從電源插座上拔下電源線。系統
- 2 卸下系統機箱蓋。
- 3 確定已正確安裝下列元件：
 - 散熱護罩
 - 擴充卡提升板 (如果已安裝)
 - 擴充卡
 - 電源供應器
 - 散熱風扇組件 (如果已安裝)
 - 散熱風扇
 - 處理器和散熱器
 - 記憶體模組
 - 硬碟機承載器或固定框架
- 4 確定所有纜線都已正確連接。
- 5 安裝系統機箱蓋。
- 6 執行適當的診斷測試。如需詳細資訊，請參閱「使用系統診斷」一節。

後續步驟

如果無法解決問題，請參閱「取得說明」一節。

故障排除系統電池

警告: 許多維修僅可由獲得認可的維修技術人員來完成。您只能依照產品說明文件中的授權說明或在線上或電話服務和支援團隊的指導下，執行故障排除和簡單的維修。由未經 **Dell** 授權的維修造成的損壞不在保固範圍之內。請閱讀並遵循產品隨附的安全說明。

註: 如果系統長時間關閉 (長達幾週或幾個月)，**NVRAM** 可能會遺失其系統組態資訊。造成此狀況的原因是電池故障。

註: 部分轉體可能會導致系統時間加快或變慢。如果系統在除 **System Setup** (系統設定) 中記錄的時間以外均運作正常，則造成問題的原因可能是軟體，而非電池故障。

步驟

- 1 在 System Setup (系統設定) 中重新輸入時間和日期。
- 2 關閉系統，然後從電源插座上拔下電源線至少一個小時。
- 3 將系統重新接上電源插座，然後啟動系統。
- 4 進入系統設定。
如果在系統設定程式中顯示的日期和時間不正確，請檢查系統電池訊息的系統錯誤日誌 (SEL)。

後續步驟

如果無法解決問題，請參閱「取得說明」一節。

故障排除電源供應器

警告: 許多維修僅可由獲得認可的維修技術人員來完成。您只能依照產品說明文件中的授權說明或在線上或電話服務和支援團隊的指導下，執行故障排除和簡單的維修。由未經 **Dell** 授權的維修造成的損壞不在保固範圍之內。請閱讀並遵循產品隨附的安全說明。

以下章節提供了有關故障排除電源和電源供應器的問題。

故障排除電源問題

- 1 按下電源按鈕，確保您的系統已開啟。如果按下電源按鈕時電源指示燈未亮起，請用力按下電源按鈕。
- 2 插上其他正常的電源供應器，確認主機板並未故障。
- 3 確定沒有連線鬆脫的狀況。
例如，電源線鬆脫。
- 4 確定電源符合適行標準。
- 5 確定沒有短路的現象。
- 6 請合格的技師檢查線路電壓，確定電壓符合所需的規格。

電源供應器問題

- 1 確定沒有連線鬆脫的狀況。
例如，電源線鬆脫。
- 2 確定電源供應器把手/LED 顯示電源供應器運作正常。
若要獲得有關電源供應器指示燈的更多資訊，請參閱 [電源供應器的電源指示燈代碼](#)。

- 3 如果您最近曾升級系統，請確定電源供應器有足夠的電源可支援新系統。
- 4 如果您具有備援電源供應器組態，請確定兩個電源供應器都有相同的類型和瓦特數。
- 5 確定您只使用背面貼有 Extended Power Performance (EPP) 標籤的電源供應器。
- 6 重新裝回電源供應器。

ⓘ 註: 安裝電源供應器之後，請等待幾秒鐘時間，讓系統辨識電源供應器並判斷是否運作正常。

如果問題仍然存在，請參閱[取得協助](#)。

故障排除散熱問題

⚠ 警告: 許多維修僅可由獲得認可的維修技術人員來完成。您只能依照產品說明文件中的授權說明或在線上或電話服務和支援團隊的指導下，執行故障排除和簡單的維修。由未經 **Dell** 授權的維修造成的損壞不在保固範圍之內。請閱讀並遵循產品隨附的安全說明。

確定已存在以下條件：

- System 護蓋、散熱護罩、EMI 填充面板、記憶體模組擋片、或背填充托架未卸下。
- 環境溫度不高於系統特定環境溫度。
- 外部空氣流通未受阻。
- 散熱風扇未卸下或未故障。
- 已遵循擴充卡安裝指引。

可使用以下其中一種方式新增額外的散熱效果：

從 iDRAC Web GUI：

- 1 按一下 **Hardware (硬體) > Fans (風扇) > Setup (設定)**。
- 2 從 **Fan Speed Offset (風扇轉速偏移)** 下拉式清單，選取需要的散熱等級，或是將最低風扇轉速設為自訂值。

從 F2 System Setup (系統設定)：

- 1 選取 **iDRAC Settings (iDRAC 設定) > Thermal (散熱)**，然後從風扇轉速偏移或最小風扇轉速設定較高的風扇轉速。

從 RACADM 命令：

- 1 執行命令 `racadm help system.thermalsettings`

如需更多資訊，請瀏覽網站 Dell.com/idracmanuals 參閱 Integrated Dell Remote Access Controller 使用者指南。

故障排除散熱風扇

⚠ 警告: 許多維修僅可由獲得認可的維修技術人員來完成。您只能依照產品說明文件中的授權說明或在線上或電話服務和支援團隊的指導下，執行故障排除和簡單的維修。由未經 **Dell** 授權的維修造成的損壞不在保固範圍之內。請閱讀並遵循產品隨附的安全說明。

ⓘ 註: 系統管理軟體會參考風扇號碼。如果特定風扇發生問題，您只需留意風扇散熱風扇組件上的號碼，便可輕易識別並進行更換。

- 1 請遵循「安全指示」一節列出的安全指南。
- 2 請遵循「拆裝系統內部元件之前」一節列出的程序。

步驟

- 1 重新安裝風扇或風扇的電源線。
- 2 重新啟動系統。

- 1 請遵循「拆裝系統內部元件之後」一節列出的程序。
- 2 如果無法解決問題，請參閱「取得說明」一節。

故障排除系統記憶體

事前準備作業

警告：許多維修僅可由獲得認可的維修技術人員來完成。您只能依照產品說明文件中的授權說明或在線上或電話服務和支援團隊的指導下，執行故障排除和簡單的維修。由未經 **Dell** 授權的維修造成的損壞不在保固範圍之內。請閱讀並遵循產品隨附的安全說明。

步驟

- 1 如果系統可正常作業，請執行適當的診斷測試。請參閱「使用系統診斷」一節，瞭解有哪些診斷測試可用。
如果診斷測試表示故障，請遵循診斷測試所修正動作操作。
- 2 如果系統無法正常作業，請關閉系統和連接的周邊裝置，然後從電源插座上拔下電源線。系統請等待至少 10 秒鐘，然後再重新連接系統電源。
- 3 開啟系統和連接的周邊裝置，並記下螢幕上顯示的訊息。
如果螢幕上顯示錯誤訊息，指出特定記憶體模組發生故障，請移往步驟 12。
- 4 進入 System Setup (系統設定)，然後檢查系統記憶體設定。如有需要，請變更記憶體設定。
如果記憶體設定與安裝的記憶體相符，但問題仍然存在，請移往步驟 12。
- 5 關閉系統和連接的周邊裝置，然後從電源插座上拔下電源線。系統
- 6 卸下系統機箱蓋。
- 7 檢查記憶體通道，並確定其已正確填充。
註：請查看系統事件記錄或系統訊息，瞭解故障記憶體模組的位置。請重新安裝記憶體裝置。
- 8 在插槽中重設記憶體模組。
- 9 安裝系統機箱蓋。
- 10 進入 System Setup (系統設定)，然後檢查系統記憶體設定。
如果問題未解決，請執行步驟 11。
- 11 卸下系統機箱蓋。
- 12 如果診斷測試或錯誤訊息指出特定記憶體模組發生故障，請將該模組替換或更換為已知功能正常的記憶體模組。
- 13 若要對未指定的故障記憶體模組進行故障排除，請將第一個 DIMM 插槽中的記憶體模組更換為相同類型和容量的模組。
如果螢幕上顯示錯誤訊息，可能表示安裝的 DIMM 類型出現問題、DIMM 未正確安裝，或是 DIMM 故障。請按照螢幕上的指示來解決問題。
- 14 安裝系統機箱蓋。
- 15 在系統啟動期間，觀察顯示的任何錯誤訊息以及系統正面的診斷指示燈。
- 16 如果記憶體問題仍然存在，請對每個已安裝的記憶體模組重複步驟 12 到步驟 15。

後續步驟

如果無法解決問題，請參閱「取得說明」一節。

故障排除內部 USB 鑰匙

事前準備作業

警告: 許多維修僅可由獲得認可的維修技術人員來完成。您只能依照產品說明文件中的授權說明或在線上或電話服務和支援團隊的指導下，執行故障排除和簡單的維修。由未經 Dell 授權的維修造成的損壞不在保固範圍之內。請閱讀並遵循產品隨附的安全說明。

步驟

- 1 進入 System Setup (系統設定)，並在 **Integrated Devices (整合裝置)** 畫面上確認已啟用 **USB key port (USB 鑰匙連接埠)**。
- 2 關閉系統和連接的周邊裝置，然後從電源插座上拔下電源線。
- 3 卸下系統機箱蓋。
- 4 找到 USB 金鑰並重新接插。
- 5 安裝系統機箱蓋。
- 6 開啟系統和連接的周邊裝置，並檢查 USB 鑰匙是否正常運作。
- 7 如果問題未解決，請重複步驟 2 和步驟 3。
- 8 插入一個已知的功能正常的 USB 金鑰。
- 9 安裝系統機箱蓋。

後續步驟

如果無法解決問題，請參閱「取得說明」一節。

故障排除 Micro SD 卡

事前準備作業

註: 某些 Micro SD 卡上有實體防寫保護開關。如果防寫保護開關已啟動，Micro SD 卡便無法寫入。

步驟

- 1 進入 System Setup (系統設定)，並確定已啟用 **Internal SD Card Port (內部 SD 卡連接埠)**。
- 2 關閉系統，包括任何連接的周邊裝置，然後從電源插座上拔下電源線。系統
- 3 卸下系統機箱蓋。

註: 當 SD 卡發生故障時，內部雙 SD 模組控制器會通知系統。在下次重新啟動時，系統便會顯示訊息，指出該項故障。若 SD 卡故障時已啟用備援，系統將會記錄嚴重警報，且機箱效能狀況將會降低。
- 4 使用新的 Micro SD 卡更換發生故障的 Micro SD 卡。
- 5 安裝系統機箱蓋。
- 6 將系統重新接上電源插座，然後啟動系統以及所有連接的周邊裝置。
- 7 進入 System Setup (系統設定)，確定 **Internal SD Card Port (內部 SD 卡連接埠)** 和 **Internal SD Card Redundancy (內部 SD 卡備援)** 模式已設定為所需的模式。
確認正確的 SD 插槽已設定為 **Primary SD Card (主要 SD 卡)**。
- 8 檢查 Micro SD 卡是否正常運作。
- 9 在 SD 卡發生故障時 **Internal SD Card Redundancy (內部 SD 卡備援)** 選項設定為 **Enabled (已啟用)**，系統將會提示您執行重建。

註: 重建始終是來自主要 SD 卡至次要 SD 卡。

故障排除光碟機

事前準備作業

警告: 許多維修僅可由獲得認可的維修技術人員來完成。您只能依照產品說明文件中的授權說明或在線上或電話服務和支援團隊的指導下，執行故障排除和簡單的維修。由未經 **Dell** 授權的維修造成的損壞不在保固範圍之內。請閱讀並遵循產品隨附的安全說明。

步驟

- 1 嘗試使用不同的 CD 或 DVD。
- 2 如果問題還是沒有解決，進入系統設定，並確定整合的 SATA 控制器和 SATA 連接埠的磁碟機已啟用。
- 3 執行適當的診斷測試。
- 4 關閉系統和連接的周邊裝置，然後從電源插座上拔下電源線。
- 5 卸下前蓋 (如已安裝)。
- 6 卸下系統機箱蓋。
- 7 確定介面纜線已牢固地連接至光碟機和控制器。
- 8 確定電源線已正確連接至光碟機。
- 9 安裝系統機箱蓋。

後續步驟

如果無法解決問題，請參閱「取得說明」一節。

故障排除磁碟機 或 SSD

警告: 此故障排除程序可以清除儲存在磁碟機的資料。請備份磁碟機的所有檔案再繼續。

警告: 許多維修僅可由獲得認可的維修技術人員來完成。您只能依照產品說明文件中的授權說明或在線上或電話服務和支援團隊的指導下，執行故障排除和簡單的維修。由未經 **Dell** 授權的維修造成的損壞不在保固範圍之內。請閱讀並遵循產品隨附的安全說明。

步驟

- 1 執行適當的診斷測試。請參閱「使用系統診斷」一節。
依據診斷測試的結果，視需要繼續完成下列步驟。
- 2 如果您的系統具有 RAID 控制器，且磁碟機設定為 RAID 陣列，請執行下列步驟：
 - a 重新啟動系統，並在系統啟動期間按下 F10，以執行 Dell Lifecycle Controller，然後執行硬體組態精靈來檢查 RAID 組態。
如需有關 RAID 組態的資訊，請參閱 Dell Lifecycle Controller 的說明文件或線上說明。
 - b 確保磁碟機已正確設為 RAID 陣列。
 - c 使磁碟機離線並重新安裝磁碟機。
 - d 結束組態公用程式，並讓系統啟動至作業系統。
- 3 確定您已正確安裝及設定控制卡所需的裝置驅動程式。如需更多資訊，請參閱作業系統說明文件。
- 4 重新啟動系統並進入系統設定。
- 5 確認控制器已啟用，且磁碟機顯示在 System Setup (系統設定) 中。

後續步驟

如果無法解決問題，請參閱「取得說明」一節。

故障排除儲存控制器

警告: 許多維修僅可由獲得認可的維修技術人員來完成。您只能依照產品說明文件中的授權說明或在線上或電話服務和支援團隊的指導下，執行故障排除和簡單的維修。由未經 **Dell** 授權的維修造成的損壞不在保固範圍之內。請閱讀並遵循產品隨附的安全說明。

註: 故障排除控制器時，請參閱作業系統和控制器的說明文件。

- 1 執行適當的診斷測試。請參閱「使用系統診斷」一節。
- 2 關閉系統和連接的周邊裝置，然後從電源插座上拔下電源線。系統
- 3 卸下系統機箱蓋。
- 4 確認已安裝的擴充卡與擴充卡安裝規範相容。
- 5 確定每個擴充卡都已穩固地插入連接器。
- 6 安裝系統機箱蓋。
- 7 將系統重新接上電源插座，然後開啟系統和連接的周邊裝置。
- 8 如果問題未解決，請關閉系統和連接的周邊裝置，然後從電源插座上拔下電源線。系統
- 9 卸下系統機箱蓋。
- 10 卸下安裝在系統中的所有擴充卡。
- 11 安裝系統機箱蓋。
- 12 將系統重新接上電源插座，然後開啟系統和連接的周邊裝置。
- 13 執行適當的診斷測試。請參閱「使用系統診斷」一節。如果測試失敗，請參閱「取得說明」一節。
- 14 對您在步驟 10 卸下的每個擴充卡執行下列步驟：
 - a 關閉系統和連接的周邊裝置，然後從電源插座上拔下電源線。系統
 - b 卸下系統機箱蓋。
 - c 重新安裝其中一個擴充卡。
 - d 安裝系統機箱蓋。
 - e 執行適當的診斷測試。請參閱「使用系統診斷」一節。

如果無法解決問題，請參閱「取得說明」一節。

故障排除擴充卡

警告: 許多維修僅可由獲得認可的維修技術人員來完成。您只能依照產品說明文件中的授權說明或在線上或電話服務和支援團隊的指導下，執行故障排除和簡單的維修。由未經 **Dell** 授權的維修造成的損壞不在保固範圍之內。請閱讀並遵循產品隨附的安全說明。

註: 對擴充卡進行故障排除時，請參閱作業系統和擴充卡的說明文件。

步驟

- 1 執行適當的診斷測試。請參閱「使用系統診斷」一節。
- 2 關閉系統和連接的周邊裝置，然後從電源插座上拔下電源線。系統
- 3 卸下系統機箱蓋。
- 4 確定每個擴充卡都已穩固地插入連接器。
- 5 安裝系統機箱蓋。
- 6 開啟系統和連接的周邊裝置。
- 7 如果問題未解決，請關閉系統和連接的周邊裝置，然後從電源插座上拔下電源線。系統
- 8 卸下系統機箱蓋。

- 9 卸下安裝在系統中的所有擴充卡。
- 10 安裝系統機箱蓋。
- 11 執行適當的診斷測試。請參閱「使用系統診斷」一節。
如果測試失敗，請參閱「取得說明」一節。
- 12 對您在步驟 8 卸下的每個擴充卡執行下列步驟：
 - a 關閉系統和連接的周邊裝置，然後從電源插座上拔下電源線。系統
 - b 卸下系統機箱蓋。
 - c 重新安裝其中一個擴充卡。
 - d 安裝系統機箱蓋。
 - e 執行適當的診斷測試。請參閱「使用系統診斷」一節。

後續步驟

如果無法解決問題，請參閱「取得說明」一節。

故障排除處理器

事前準備作業

警告：許多維修僅可由獲得認可的維修技術人員來完成。您只能依照產品說明文件中的授權說明或在線上或電話服務和支援團隊的指導下，執行故障排除和簡單的維修。由未經 **Dell** 授權的維修造成的損壞不在保固範圍之內。請閱讀並遵循產品隨附的安全說明。

步驟

- 1 執行適當的診斷測試。請參閱「使用系統診斷」一節。
- 2 關閉系統和連接的周邊裝置，然後從電源插座上拔下電源線。系統
- 3 卸下系統機箱蓋。
- 4 確定已正確安裝處理器和散熱器。
- 5 安裝系統機箱蓋。
- 6 執行適當的診斷測試。請參閱「使用系統診斷」一節。
- 7 如果無法解決問題，請參閱「取得說明」一節。

系統訊息

如需監視系統元件之系統軟體和代理程式產生的事件和錯誤訊息清單，請參閱 Dell 事件與錯誤訊息參考指南，位於 [Dell.com/openmanagemanuals > OpenManage software](https://www.dell.com/support/manuals)。

Warning messages

A warning message alerts you to a possible problem and prompts you to respond before the system continues a task. For example, before you format a hard drive, a message warns you that you may lose all data on the hard drive. Warning messages usually interrupt the task and need you to respond by typing y (yes) or n (no).

NOTE: 警告訊息是由應用程式或作業系統產生。如需更多資訊，請參閱作業系統或應用程式隨附的說明文件。

Diagnostic messages

The system diagnostic utility generates messages if there are errors detected when you run diagnostic tests on your system. For more information about system diagnostics, see the Using system diagnostics section.

Alert messages

The systems management software generates alert messages for your system. Alert messages include information, status, warning, and failure messages for drive, temperature, fan, and power conditions. For more information, see the systems management software documentation links listed in the Documentation resources section of this manual.

獲得幫助

主題：

- [Contacting Dell](#)
- [使用 QRL 存取系統資訊](#)

Contacting Dell

Dell provides several online and telephone based support and service options. If you do not have an active internet connection, you can find contact information about your purchase invoice, packing slip, bill, or Dell product catalog. Availability varies by country and product, and some services may not be available in your area. To contact Dell for sales, technical assistance, or customer service issues:

- 1 Go to [Dell.com/support](#).
- 2 Select your country from the drop-down menu on the lower right corner of the page.
- 3 For customized support:
 - a Enter your system Service Tag in the **Enter your Service Tag** field.
 - b Click **Submit**.The support page that lists the various support categories is displayed.
- 4 For general support:
 - a Select your product category.
 - b Select your product segment.
 - c Select your product.The support page that lists the various support categories is displayed.
- 5 For contact details of Dell Global Technical Support:
 - a Click [Global Technical Support](#).
 - b The **Contact Technical Support** page is displayed with details to call, chat, or e-mail the Dell Global Technical Support team.

使用 QRL 存取系統資訊

您可以使用快速資源定位器 (QRL) 以立即存取您系統的相關資訊。

事前準備作業

請確保您的智慧型手機或平板電腦有安裝 QR 碼掃描器。

關於此工作

QRL 包含下列有關您系統的資訊：

- 教學影像
- 參考資料，包括擁有者手冊、LCD 診斷和機械概觀
- 您的系統服務標籤，以便快速存取您的特定硬體組態及保固資訊
- 直接連結到 Dell 聯絡技術支援和銷售團隊

步驟

- 1 移至 [Dell.com/QRL](#) 並導覽至您的特定產品或
- 2 使用您的智慧型手機或平板電腦掃描位於下列影像、或在 Dell PowerEdge 系統上的特定型號快速資源 (QR) 碼：



Quick Resource Locator



www.dell.com/QRL/Server/PET130