

Dell EMC PowerEdge RAID Controller (PERC) 10 User's Guide

Notes, cautions, and warnings

 **NOTE:** A NOTE indicates important information that helps you make better use of your product.

 **CAUTION:** A CAUTION indicates either potential damage to hardware or loss of data and tells you how to avoid the problem.

 **WARNING:** A WARNING indicates a potential for property damage, personal injury, or death.

Copyright © 2017 Dell Inc. or its subsidiaries. All rights reserved. Dell, EMC, and other trademarks are trademarks of Dell Inc. or its subsidiaries. Other trademarks may be trademarks of their respective owners.

Contents

1 Overview	7
Supported operating systems	7
PERC card specifications	7
Management applications for PERC cards	8
Comprehensive embedded management	8
Dell OpenManage Storage Management	9
Related documentation	9
2 Getting Started	10
3 Features	12
Controller features	12
FastPath	12
Disk roaming	13
1 MB IO	13
Physical disk power management	13
Secure firmware update	14
PERC H840 enclosure support	14
Virtual disk features	15
Virtual disk write cache policies	16
Virtual disk read cache policies	16
Virtual disk migration	17
Virtual disk initialization	17
Reconfiguration of virtual disks	18
Background operations	20
Hard drive features	20
Self-Encrypting Disks	20
ISE	21
4 KB sector disk drives	21
Fault tolerance	21
The SMART feature	21
Patrol Read	22
Physical disk failure detection	22
Using persistent hot spare slots	22
Physical disk hot swapping	23
Using replace member and revertible hot spares	23
Controller cache preservation	23
Battery Transparent Learn Cycle	24
4 Deploying the PERC card	25
Removing the PERC H740P adapter	25
Installing the PERC H740P adapter	26

Removing the PERC H740P mini monolithic.....	27
Installing the PERC H740P mini monolithic.....	28
Removing the PERC H840 card.....	29
Installing the PERC H840 card.....	30
5 Driver installation.....	31
Creating the device driver media.....	31
Downloading drivers from the Dell support website.....	31
Downloading drivers from the Dell systems service and diagnostic tools media	32
Windows driver installation.....	32
Installing the driver during a Windows Server 2012 R2 and newer installation.....	32
Installing the driver after Windows Server 2012 R2 and newer installation	32
Updating PERC 10 driver for existing Windows Server 2012 R2 and newer.....	33
Linux driver installation.....	33
Installing or updating the RPM driver package with KMOD support.....	34
Installing or updating the RPM driver package with KMP support.....	34
Loading the driver during operating system installation.....	34
6 Firmware.....	36
Installing the firmware using DUP.....	36
7 HII configuration utility.....	37
Entering the HII configuration utility.....	37
Exiting the HII configuration utility.....	37
Navigating to Dell PERC 10 configuration utility.....	37
HII Configuration utility Dashboard View options.....	38
Configuration management.....	39
Creating the virtual disks.....	39
Configuring virtual disk parameters.....	39
Creating profile based virtual disk.....	40
Viewing Disk Group Properties.....	41
Deleting Configurations.....	41
Controller management.....	41
Clearing controller events.....	41
Saving controller events.....	41
Saving debug log.....	41
Managing link speed.....	42
Restoring factory default settings.....	42
Advanced controller properties.....	42
Virtual disk management.....	45
Viewing virtual disk properties.....	45
Viewing physical disks associated with a virtual disk.....	46
Configuring virtual disk policies.....	46
Performing break mirror operation.....	47
Performing expand virtual disk operation.....	47
Performing consistency check.....	48

Physical disk management.....	48
Viewing physical disk properties.....	48
Secure erase.....	49
Cryptographic erase.....	50
Physical disk erase.....	50
Assigning global hot spare.....	51
Assigning dedicated hot spare.....	51
Hardware components.....	51
Viewing battery properties.....	51
Viewing physical disks associated with an enclosure.....	52
8 Security key and RAID management.....	53
Security key implementation.....	53
Security key management in the HII configuration utility.....	53
Local Key Management (LKM).....	53
Creating security key.....	53
Changing security key.....	54
Disabling security key.....	54
Creating secured virtual disk.....	54
Securing pre-existing virtual disk.....	55
Importing secure virtual disk.....	55
9 Troubleshooting.....	56
Adapter at baseport not responding error message.....	56
BIOS disabled error message.....	56
Configured disks removed or not accessible error message.....	57
Dirty cache data error message.....	57
Discovery error message.....	57
Drive Configuration Changes Error Message.....	57
Windows operating system installation errors	58
Firmware fault state error message.....	58
Extra enclosure error message.....	58
Foreign configuration found error message.....	58
Foreign configuration not found in HII error message.....	58
Degraded state of virtual disks.....	59
Memory errors.....	59
Preserved Cache State.....	59
Security key errors.....	59
Secured foreign import errors.....	59
Failure to select or configure non Self-Encrypting Disks (non-SED).....	60
Failure to delete security key.....	60
Failure to secure erase task on physical disks.....	60
General issues.....	60
PERC card has yellow bang in device manager.....	60
PERC card not seen in device manager.....	60
Physical disk issues.....	61

Physical disk in failed state.....	61
Unable to rebuild a fault tolerant virtual disk.....	61
Fatal error or data corruption reported.....	61
Physical disk displayed as blocked.....	61
Multiple disks become inaccessible.....	61
Rebuilding a failed physical disk.....	62
Virtual disk fails during rebuild using a global hot spare.....	62
Virtual disk fails during rebuild using a dedicated hot spare.....	62
Physical disk fails during reconstruction on redundant virtual disk.....	62
Virtual disk fails rebuild using a dedicated hot spare.....	62
Physical disk takes a long time to rebuild.....	63
SMART errors.....	63
Smart error detected on a physical disk in a redundant virtual disk.....	63
Smart error detected on a physical disk in a non-redundant virtual disk.....	63
Replace member errors.....	64
Source disk fails during replace member operation.....	64
Target disk fails.....	64
General disk fails.....	64
Linux operating system errors.....	64
Virtual disk policy is assumed as write-through error message.....	64
Unable to register SCSI device error message.....	65
Disk carrier LED indicators.....	65
HII error messages.....	66
Unhealthy Status of the Drivers.....	66
10 Appendix: RAID description.....	67
Summary of RAID levels.....	67
RAID terminology.....	68
Disk striping.....	68
Disk mirroring.....	68
Spanned RAID levels.....	69
Parity data.....	69
11 Getting help.....	70
Contacting Dell.....	70
Documentation feedback.....	70

Overview

The PowerEdge RAID Controller (PERC) 10 Series of cards consist of the H740P and H840 cards. The PERC 10 family of storage controller cards has the following characteristics:

- Complies with serial-attached SCSI (SAS) 3.0 providing up to 12 Gb/sec throughput.
- Supports Dell-qualified serial-attached SCSI (SAS) hard drives, SATA hard drives, and solid-state drives (SSDs).
 - ① **NOTE: Mixing SAS and SATA drives within a virtual disk is not supported. Also, mixing hard drives and SSDs within a virtual disk is not supported.**
 - ① **NOTE: Mixing disks of different speed (7,200 rpm, 10,000 rpm, or 15,000 rpm) and bandwidth (3 Gbps or 6 Gbps) PCIe while maintaining the same drive type (SAS or SATA) and technology (HDD or SSD) is supported.**
- Offers RAID control capabilities which include support for RAID levels 0, 1, 5, 6, 10, 50, and 60.
- Provides reliability, high performance, and fault-tolerant disk subsystem management.

Topics:

- [Supported operating systems](#)
- [PERC card specifications](#)
- [Management applications for PERC cards](#)
- [Related documentation](#)

Supported operating systems

The PERC 10 series cards support the following operating systems:

- Microsoft Windows Server 2012 R2
- Microsoft Windows Server 2016
- VMware ESXi 6.5
- VMware ESXi 6.0 Update 3

① **NOTE: The PERC 10 driver for VMware ESXi is bundled with the VMware ISO image available from Dell. For more information, see Dell.com/virtualizationsolutions.**

- Red Hat Enterprise Linux version 6.9
- Red Hat Enterprise Linux version 7.3
- SUSE Linux Enterprise Server version 12.2

① **NOTE: For the latest list of supported operating systems and driver installation instructions, see the system documentation at Dell.com/support/manuals. For specific operating system service pack requirements, see the Drivers and Downloads section at Dell.com/support/manuals.**

PERC card specifications

The table below lists and describes the different PERC cards that comprise the PERC 10 series and their specifications:

Table 1. PERC cards

Feature	PERC H740P	PERC H840
RAID Levels	0, 1, 5, 6, 10, 50, 60	0, 1, 5, 6, 10, 50, 60
Enclosures per port	Not applicable	1
Processor	Dell Adapter SAS RAID-on-Chip, 8-port with LSI 3508 chipset	Dell Adapter SAS RAID-on-Chip, 8-port with LSI 3508 chipset
Battery Backup Unit	Yes	Yes
Non-Volatile cache	Yes	Yes
Cache memory	8 GB DDR4 2133 Mhz cache	8 GB DDR4 2133 Mhz cache
Cache function	Write Back, Write Through, No Read Ahead, and Read Ahead	Write Back, Write Through, No Read Ahead, and Read Ahead
Maximum number of virtual disks	64	64
Maximum number of virtual disks per disk group	16	16
Hot swap devices supported	Yes	Yes
Hardware XOR Engine	Yes	Yes
Online capacity expansion	Yes	Yes
Dedicated and global hot spare	Yes	Yes
Drives Types	3 Gbps SATA, 6 Gbps SATA/SAS, and 12 Gbps SAS	6 Gbps SAS, and 12 Gbps SAS
PCIe Support	Gen 3	Gen 3
Non-RAID or pass through mode	No	No

Management applications for PERC cards

Dell OpenManage Storage Management applications enable you to manage and configure the RAID system, create and manage multiple disk groups, control and monitor multiple RAID systems, and provide online maintenance. The management applications for all PERC cards include:

- Comprehensive Embedded Management
- Dell OpenManage Storage Management
- Human Interface Infrastructure (HII) Configuration Utility
- PERC CLI

NOTE: The BIOS configuration utility <Ctrl> <R> is not supported on the PERC 10 cards.

Comprehensive embedded management

Comprehensive Embedded Management (CEM) is a storage management solution for Dell systems that enables you to effectively monitor the RAID and network controllers installed on the system using iDRAC without an OS installed on the system.

Using CEM enables you to perform the following:

- Monitor devices without an OS installed on the system.
- Provide a specific location to access monitored data of the storage devices and network cards.
- Allows controller configuration for all the PERC 10 cards (H740P and H840).

NOTE: If you boot the system to HII (F2) or Lifecycle Controller (F10), then you cannot view the PERC cards on the CEM GUI. The PERC cards are displayed on the CEM GUI only after the system boot is complete.

Dell OpenManage Storage Management

The Dell OpenManage Storage Management is a storage management application for Dell systems that provides enhanced features for configuring a system's locally-attached RAID disk storage. The Dell OpenManage storage management application enables you to perform controller and enclosure functions for all supported RAID controllers and enclosures from a single graphical or command-line interface. The graphical user interface (GUI) is wizard-driven with features for novice and advanced users, and detailed online help. Using the Dell OpenManage storage management application, you can protect your data by configuring data-redundancy, assigning hot spares, or rebuilding failed physical disks. The command line interface available on selected operating systems to perform RAID management tasks is fully featured and scriptable.

NOTE: For more information, see the *Dell OpenManage Storage Management User's Guide* at Dell.com/openmanagemanuals.

Related documentation

NOTE:

- For all storage controllers and PCIe SSD documents, go to Dell.com/storagecontrollermanuals.
- For all Dell OpenManage documents, go to Dell.com/openmanagemanuals.
- For all operating system documents, go to Dell.com/operatingsystemmanuals.
- For all PowerEdge documentation, go to Dell.com/poweredgemanuals.
- For all PowerVault documentation, go to Dell.com/powervaultmanuals.

Getting Started

The Dell PowerEdge RAID Controller (PERC) 10 Series of cards consist of the H740P and H840 cards.

- **PERC H740P:** The PERC H740P is the performance RAID solution card consisting of 8 GB Non-Volatile Cache and is available in the Adapter (low profile and full height) and Mini Monolithic form factors for internal storage.

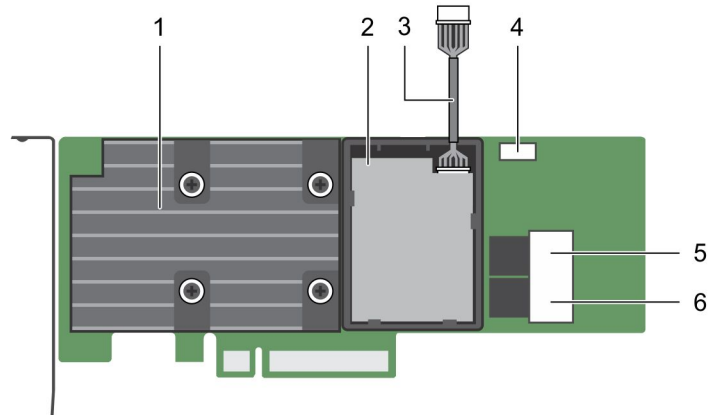

Figure 1. Features of PERC H740P adapter

- | | |
|----------------------|---------------------------|
| 1 PERC H740P adapter | 2 battery |
| 3 battery cable | 4 battery cable connector |
| 5 port B | 6 port A |

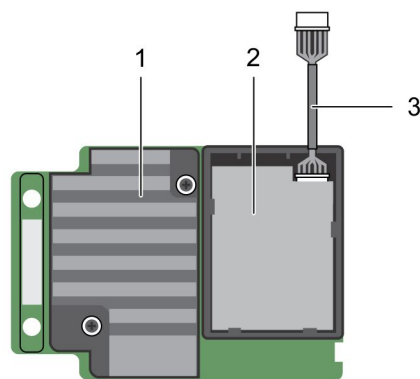

Figure 2. Features of PERC H740P mini monolithic card

- | | |
|-----------------------------------|-----------|
| 1 PERC H740P mini monolithic card | 2 battery |
|-----------------------------------|-----------|

3 battery cable

- **PERC H840:** The PERC H840 is similar to the H740P solution, except that it supports external storage. The PERC H840 is only available in the Adapter (low profile and full height) form factor.

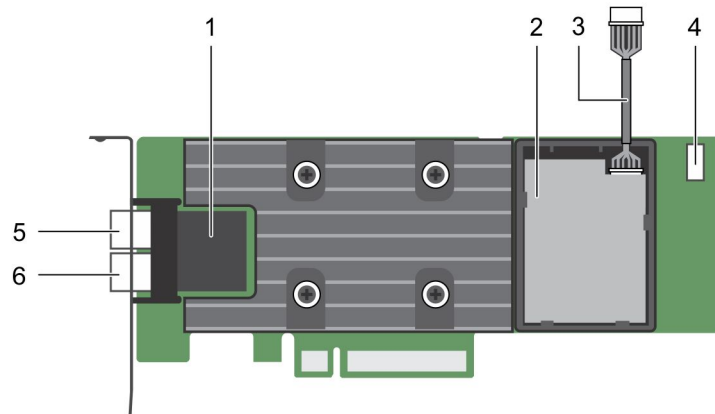

Figure 3. Features of PERC H840 adapter card

- | | |
|---------------------|---------------------------|
| 1 PERC H840 adapter | 2 battery |
| 3 battery cable | 4 battery cable connector |
| 5 port A/0 | 6 port B/1 |

Controller features

This section lists the following controller features supported on PowerEdge RAID Controller (PERC) 10 cards in detail:

- FastPath
- Disk roaming
- 1 MB IO
- Physical disk power management
- Secure firmware update
- Redundant path support for PERC H840

FastPath

FastPath is a feature that improves application performance by delivering high I/O per second (IOPs) for Solid State Drives (SSD). The Dell PowerEdge RAID Controller (PERC) 10 series supports FastPath.

To enable **FastPath** on a virtual disk the Dell PowerEdge RAID Controller (PERC) 10 series cache policies need to be set to **Write-Through** and **No Read Ahead**. This enables **FastPath** to use the proper data path through the controller based on command (read/write), IO size, and RAID type.

Configuring Virtual Disks

When configuring the virtual disks, you should consider the workload intended; RAID1: for simple boot disk; RAID5 or 6: for file or web servers (sequential reads/writes of files); RAID10: for transactional database (small random reads and writes).

Virtual disks configured on hard drives should use the controller default cache setting of Write Back and Read Ahead.

Virtual disks configured on SSDs can use the same controller defaults settings as hard drives. Most users perform a copy of OS files or a data base to the new array. This setting provides optimum performance in this configuration.

Once the copy is complete, the array can be used as it is depending on the number and type of SSDs. It is recommended to enable FastPath by changing the controller's Write cache policy to Write Through and the Read cache policy to No Read Ahead. FastPath is developed to achieve the best random read/write performance from SSDs.

Only IO block sizes smaller than the virtual disk's stripe size are eligible for FastPath. In addition, there should be no background operations (rebuild, initialization) running on the virtual disks. FastPath is disabled if there is active background operation.

NOTE: RAID 50, and RAID 60 virtual disks cannot use FastPath.

NOTE: The Physical Disk Power Management feature is not applicable to FastPath-capable virtual disks.

Disk roaming

Disk roaming is moving the physical disks from one cable connection or backplane slot to another on the same controller. The controller automatically recognizes the relocated physical disks and logically places them in the virtual disks that are part of the disk group. You can perform disk roaming only when the system is turned off.

⚠ CAUTION: Do not attempt disk roaming during RAID level migration (RLM) or online capacity expansion (OCE). This causes loss of the virtual disk.

Using disk roaming

Perform the following steps to use disk roaming:

- 1 Turn off the power to the system, physical disks, enclosures, and system components.
- 2 Disconnect power cables from the system.
- 3 Move the physical disks to desired positions on the backplane or the enclosure.
- 4 Perform a safety check. Make sure the physical disks are inserted properly.
- 5 Turn on the system.

The controller detects the RAID configuration from the configuration data on the physical disks.

1 MB IO

The H740P and H840 controllers support 1 MB IO feature. If the capacity of IO frame is greater than 1 MB, the IO frame is broken into smaller chunks.

ⓘ NOTE: You can enable or disable the Large IO support feature using HII or PERC CLI. By default, the Large IO support option is enabled for the PERC 10 series of cards.

Physical disk power management

Physical disk power management is a power-saving feature of the PERC 10 series cards. The feature allows disks to be spun down based on disk configuration and I/O activity. The feature is supported on all rotating SAS and SATA disks and includes unconfigured, configured, and hot-spare disks. The physical disk power management feature is disabled by default. The feature can be enabled in the Dell Open Manage Storage Management application or **Human Interface Infrastructure (HII) Configuration** utility. For more information, see the Dell OpenManage documentation at Dell.com/openmanagemanuals.

There are four power-saving modes:

- | | |
|--|--|
| No Power Savings
(<i>default mode</i>) | All power savings features are disabled. |
| Balanced Power Savings | Spin down is enabled only for unconfigured and hot spare disks. |
| Maximum Power Savings | Spin down is enabled for configured, unconfigured, and hot spare disks. |
| Customized Power Savings | All power savings features are customizable. You can specify a Quality of Service window during which the configured disks are excluded from spin-down. |

Secure firmware update

This feature provides a cryptographic method of updating the firmware using RSA encryption-decryption algorithm.

Only Dell certified firmware is supported on your PERC controller.

PERC H840 enclosure support

The H840 card is an external card. The H840 card supports:

- up to one enclosure using multipath configuration.
- up to two enclosures using single path configuration.

To set up a configuration with redundant paths, both ports on a controller must be cabled to the ports of a single enclosure.

NOTE: The PERC H840 card supports redundant paths when used with Dell PowerVault MD14XX series disk storage enclosures.

To set up an enclosure on the PERC H840 card:

- To connect single enclosure, cable the ports such that the enclosure is connected to both the ports on the controller card.

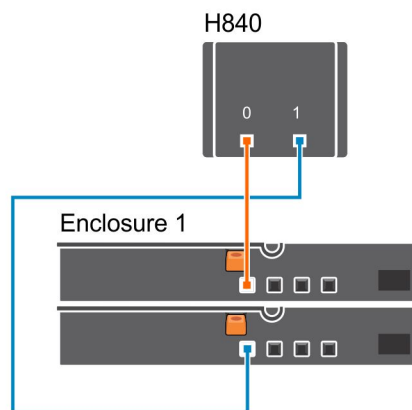

Figure 4. PERC H840 card ports — Single enclosure with multipath configuration

- To connect multiple enclosures, cable the ports such that the first and second enclosures are connected to ports 0 and 1 on the card respectively.

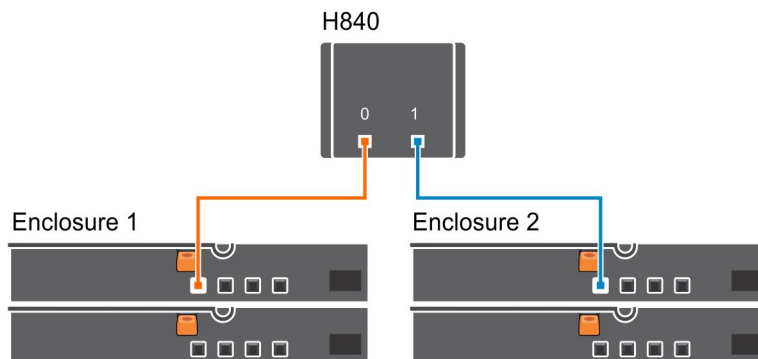

Figure 5. PERC H840 card ports — Two enclosures with single path configuration

Redundant path support for PERC H840

The PERC H840 adapter can detect and use redundant paths to disks contained in enclosures. This provides the ability to connect two SAS cables between a controller and an enclosure for path redundancy. The controller is able to tolerate the failure of a cable or Enclosure Management Module (EMM) by utilizing the remaining path. When redundant paths exist, the controller automatically balances I/O load through both paths to each disk. Load balancing increases throughput to virtual disks in storage enclosures and is automatically turned on when redundant paths are detected. To set up your hardware to support redundant paths, see [Setting up redundant path support on the PERC H840 adapter](#).

NOTE: This is applicable for PERC H840 only.

NOTE: This support for redundant paths refers to path redundancy only and not to controller redundancy.

Setting up redundant path support on the PERC H840 adapter

The PERC H840 card can detect and use redundant paths to disks contained in enclosures. With redundant paths to the same device, if one path fails, another path can be used to communicate between the controller and the device.

To connect single enclosure, cable the ports such that the enclosure is connected to both the ports on the controller card.

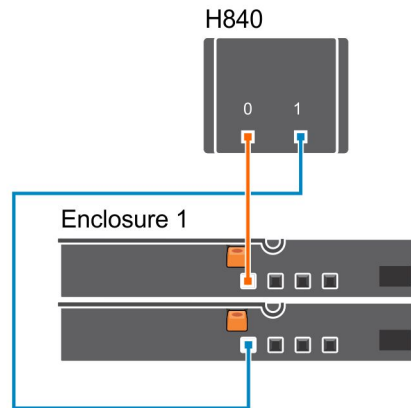

Figure 6. PERC H840 card ports — Single enclosure with multipath configuration

Virtual disk features

This section lists the following virtual disk features supported on PowerEdge RAID Controller (PERC) 10 cards in detail:

- Virtual disk write cache policy
- Virtual disk read cache policy
- Virtual disk migration
- Virtual disk Initialization
- Reconfiguration of virtual disk
- Background operations

Virtual disk write cache policies

The write cache policy of a virtual disk determines how the controller handles writes to the virtual disk.

Table 2. Write cache policies

Write-Back

The controller sends a data transfer completion signal to the host when the controller cache has received all the data in a transaction. The controller then writes the cached data to the storage device in the background.

NOTE: The default cache setting for virtual disks is **Write-Back caching**. Write-back caching is also supported for single drive RAID 0 virtual disks.

Write-Through

The controller sends a data transfer completion signal to the host system when the disk subsystem has received all the data in a transaction.

All RAID volumes are presented as **Write-Through** to the operating system (Windows and Linux) independent of the actual write cache policy of the virtual disk. The PERC cards manage the data in cache independently of the operating system or any applications.

NOTE: Certain data patterns and configurations perform better with a **Write-Through** cache policy.

NOTE: Use the Dell OpenManage storage management application or the HII Configuration Utility to view and manage virtual disk cache settings.

Conditions under which write-back is employed

Write-Back caching is used under all conditions in which the battery is present and in good condition.

Conditions under which forced write-back with no battery is employed

CAUTION: It is recommended that you use a power backup system when forcing **Write-Back** to ensure there is no loss of data if the system suddenly loses power.

Write-Back mode is available when you select **Force WB with no battery**. When **Forced Write-Back** mode is selected, the virtual disk is in **Write-Back** mode even if the battery is not present.

Virtual disk read cache policies

The read policy of a virtual disk determines how the controller handles reads to that virtual disk.

Table 3. Read policies

Read Ahead

Allows the controller to read sequentially ahead of requested data and to store the additional data in cache memory, anticipating that

the data is required soon. This speeds up reads for sequential data, but there is little improvement when accessing random data.

Disables the **Read-Ahead** capability.

No Read Ahead

Virtual disk migration

The PERC 10 series supports migration of virtual disks from one controller to another without taking the target controller offline. The controller can import RAID virtual disks in optimal, degraded, or partially degraded states. You cannot import a virtual disk that is offline. Disk migration pointers:

- Supports migration of virtual disks from PERC H330, H730, H730P, and H830 to PERC 10 series
- Supports migration of volumes created within PERC 10 series
- Does not support migration from PERC 10 series to H310, H710, H710P, H810

NOTE: The source controller must be offline prior to performing the disk migration.

NOTE: Importing non-RAID drives and uneven span RAID 10 virtual disks from PERC 9 to PERC 10 are not supported.

NOTE: Disks cannot be migrated to older generations of the PERC cards.

NOTE: Importing secured virtual disks is supported as long as the appropriate Local Key Management (LKM) is supplied or configured.

When a controller detects a configured physical disk, it flags the physical disk as foreign, and generates an alert indicating that a foreign disk was detected.

CAUTION: Do not attempt disk migration during RLM or online capacity expansion (OCE). This causes loss of the virtual disk.

Virtual disk initialization

PERC 10 series supports two types of virtual disk initialization:

- Full Initialization
- Fast Initialization

CAUTION: Initializing virtual disks erases files and file systems while keeping the virtual disk configuration intact.

Full initialization

Performing a full initialization on a virtual disk overwrites all blocks and destroys any data that previously existed on the virtual disk. Full initialization of a virtual disk eliminates the need for the virtual disk to undergo a Background initialization (BGI). Full initialization can be performed after the virtual disk is created.

During full initialization, the host cannot access the virtual disk. You can start a full initialization on a virtual disk by using the **Slow Initialize** option in the Dell OpenManage storage management application. For more information on using the **HII Configuration Utility** to perform a full initialization, see [Configuring virtual disk parameters](#).

NOTE: If the system reboots during a full initialization, the operation aborts and a BGI begins on the virtual disk.

Fast initialization

A fast initialization on a virtual disk overwrites the first and last 8 MB of the virtual disk, clearing any boot records or partition information. The operation takes only 2–3 seconds to complete, but it is followed by BGI, which takes a longer time to complete. To perform a fast initialization using the **HII Configuration Utility**, see [Configuring virtual disk parameters](#).

Reconfiguration of virtual disks

An online virtual disk can be reconfigured in ways that expands its capacity and/or change its RAID level.

NOTE: Spanned virtual disks such as RAID 50 and 60 cannot be reconfigured.

NOTE: Reconfiguring Virtual Disks typically impacts disk performance until the reconfiguration operation is complete.

Online Capacity Expansion (OCE) can be done in two ways:

- If there is a single virtual disk in a disk group and free space is available, the virtual disk's capacity can be expanded within that free space. If multiple virtual disks exist within a common disk group, those virtual disk's capacities cannot be expanded.
- If a virtual disk is created and it does not use the maximum size of the disk group, free space is available.

Free space is also available when a disk group's physical disks are replaced by larger disks using the **Replace Member** feature. A virtual disk's capacity can also be expanded by performing an OCE operation to add more physical disks.

RAID Level Migration (RLM) refers to changing a virtual disk's RAID level. Both RLM and OCE can be done at the same time so that a virtual disk can simultaneously have its RAID level changed and its capacity increased. When a RLM/OCE operation is complete, a reboot is not required. The source RAID level column indicates the virtual disk RAID level before the RLM/OCE operation and the target RAID level column indicates the RAID level after the RLM/OCE operation.

NOTE: If the controller already contains the maximum number of virtual disks, you cannot perform a RAID level migration or capacity expansion on any virtual disk.

NOTE: The controller changes the write cache policy of all virtual disks undergoing a RLM/OCE operation to Write-Through until the RLM/OCE operation is complete.

See the following table for a list of RLM/OCE possibilities.

Table 4. RAID level migration

Source RAID Level	Target RAID Level	Number of Physical Disks (Beginning)	Number of Physical Disks (End)	Capacity Expansion Possible	Description
RAID 0	RAID 0	1	2 or more	Yes	Increases capacity by adding disks.
RAID 0	RAID 1	1	2	No	Converts a non-redundant virtual disk into a mirrored virtual disk by adding one disk.
RAID 0	RAID 5	1 or more	3 or more	Yes	At least one disk needs to be added for distributed parity data.

Source RAID Level	Target RAID Level	Number of Physical Disks (Beginning)	Number of Physical Disks (End)	Capacity Expansion Possible	Description
RAID 0	RAID 6	1 or more	4 or more	Yes	At least two disks need to be added for dual distributed parity data.
RAID 1	RAID 0	2	2 or more	Yes	Removes redundancy while increasing capacity.
RAID 1	RAID 5	2	3 or more	Yes	Maintains redundancy while doubling capacity.
RAID 1	RAID 6	2	4 or more	Yes	Two disks required to be added for distributed parity data.
RAID 5	RAID 0	3 or more	3 or more	Yes	Converts to a non-redundant virtual disk and reclaims disk space used for distributed parity data.
RAID 5	RAID 5	3 or more	4 or more	Yes	Increases capacity by adding disks.
RAID 5	RAID 6	3 or more	4 or more	Yes	At least one disk needs to be added for dual distributed parity data.
RAID 6	RAID 0	4 or more	4 or more	Yes	Converts to a non-redundant virtual disk and reclaims disk space used for distributed parity data.
RAID 6	RAID 5	4 or more	4 or more	Yes	Removes one set of parity data and reclaims disk space used for it.
RAID 6	RAID 6	4 or more	5 or more	Yes	Increases capacity by adding disks
RAID 10	RAID 10	Less than 32	32	Yes	Increases capacity by adding disks

NOTE: The total number of physical disks in a disk group cannot exceed 32. You cannot perform RAID level migration and expansion on RAID levels 50 and 60.

Background operations

Background initialization

Background Initialization (BGI) is an automated process that writes the parity or mirror data on newly created virtual disks. BGI does not run on RAID 0 virtual disks. You can control the BGI rate in the Dell OpenManage storage management application. Any change in the BGI rate does not take effect until the next BGI run.

NOTE: You cannot disable BGI permanently. If you cancel BGI, it automatically restarts within five minutes.

NOTE: Unlike full or fast initialization of virtual disks, background initialization does not clear data from the physical disks.

NOTE: Consistency Check (CC)/BGI typically causes some loss in performance until the operation completes.

Consistency Check (CC) and BGI perform similar functions in that they both correct parity errors. However, CC reports data inconsistencies through an event notification, but BGI does not. You can start CC manually, but not BGI.

Consistency checks

Consistency Check (CC) is a background operation that verifies and corrects the mirror or parity data for fault tolerant virtual disks. It is recommended that you periodically run a consistency check on virtual disks.

You can manually start a CC using the **HII Configuration Utility** or the Dell OpenManage storage management application. You can schedule a CC to run on virtual disks using the Dell OpenManage storage management application. To start a CC using the **HII Configuration Utility**, see [Performing consistency check](#).

NOTE: CC/BGI typically causes some loss in performance until the operation completes.

Consistency Check (CC) and BGI both correct parity errors. However, CC reports data inconsistencies through an event notification, but BGI does not. You can start CC manually, but not BGI.

Hard drive features

This section lists the following hard drive features supported on PowerEdge RAID Controller (PERC) 10 cards in detail:

- Self-Encrypting Disks (SED)
- Instant Secure Erase (ISE)
- 4KB block size disk drives

Self-Encrypting Disks

The Dell PowerEdge RAID Controller (PERC) 10 series of cards support Self-Encrypting Disks (SED) for protection of data against loss or theft of SEDs. Protection is achieved by the use of encryption technology on the drives. There is one security key per controller. You can manage the security key under Local Key Management (LKM). The security key is used by the controller to lock and unlock access to encryption-capable physical disks. In order to take advantage of this feature, you must:

- Have SEDs in your system.
- Create a security key.

For more information, see the [Security key and RAID management](#) section.

NOTE: You cannot enable SED on non-optimal virtual disks.

ISE

ISE drives use the same encryption technology as SED drives but do not allow the encryption key to be secured. The encryption technology allows the drive to be re-purposed and securely erased using the Cryptographic erase function.

NOTE: ISE drives do not provide protection against theft.

4 KB sector disk drives

PERC H740P and H840 cards support 4 KB sector disk drives, which enable you to efficiently use the storage space. Before installing Windows on 4 KB sector drives, refer [Windows operating system installation errors](#) .

NOTE:

- Mixing 512-byte native and 512-byte emulated drives in a virtual disk is allowed, but mixing 512-byte and 4 KB native drives in a virtual disk is not allowed.
- You can only boot from a 4 KB sector drive in UEFI mode.
- 4K is only supported in UEFI mode and not legacy BIOS

Fault tolerance

The PERC 10 series supports the following:

- Self Monitoring and Reporting Technology (SMART)
- Patrol Read
- Physical disk failure detection
- Physical disk rebuild using hot spares
- Controller cache preservation
- Battery and non-volatile cache backup of controller cache to protect data
- Detection of batteries with low charge after boot up

The next sections describe some methods to achieve fault tolerance.

The SMART feature

The SMART feature monitors certain physical aspects of all motors, heads, and physical disk electronics to help detect predictable physical disk failures. Data on SMART-compliant physical disks can be monitored to identify changes in values and determine whether the values are within threshold limits. Many mechanical and electrical failures display some degradation in performance before failure.

A SMART failure is also referred to as predicted failure. There are numerous factors that are predicted physical disk failures, such as a bearing failure, a broken read/write head, and changes in spin-up rate. In addition, there are factors related to read/write surface failure, such as seek error rate and excessive bad sectors.

NOTE: For detailed information on SCSI interface specifications, see t10.org and for detailed information on SATA interface specifications, see t13.org.

Automatic replace member with predicted failure

A **Replace Member** operation can occur when there is a SMART predictive failure reporting on a physical disk in a virtual disk. The automatic **Replace Member** is initiated when the first SMART error occurs on a physical disk that is part of a virtual disk. The target disk needs to be a hot spare that qualifies as a rebuild disk. The physical disk with the SMART error is marked as **failed** only after the successful completion of the **Replace Member**. This prevents the array from reaching degraded state.

If an automatic **Replace Member** occurs using a source disk that was originally a hot spare (that was used in a rebuild), and a new disk added for the **Replace Member** operation as the target disk, the hot spare reverts to the hot spare state after a successful **Replace Member** operation.

NOTE: To enable the automatic **Replace Member**, use the Dell OpenManage storage management application.

Patrol Read

The **Patrol Read** feature is designed as a preventative measure to ensure physical disk health and data integrity. **Patrol Read** scans and resolves potential problems on configured physical disks. The Dell OpenManage storage management application can be used to start **Patrol Read** and change its behavior.

The following is an overview of **Patrol Read** behavior:

- **Patrol Read** runs on all disks on the controller that are configured as part of a virtual disk, including hot spares.
- **Patrol Read** does not run on physical disks that are not part of a virtual disk or are in **Ready** state.
- **Patrol Read** adjusts the amount of controller resources dedicated to **Patrol Read** operations based on outstanding disk I/O. For example, if the system is busy processing I/O operation, then **Patrol Read** uses fewer resources to allow the I/O to take a higher priority.
- **Patrol Read** does not run on any disks involved in any of the following operations:
 - Rebuild
 - Replace Member
 - Full or Background Initialization
 - CC
 - RLM or OCE

NOTE: By default, **Patrol Read** automatically runs every seven days on configured SAS and SATA hard drives. **Patrol Read** is not necessary on SSD and is disabled by default.

For more information on **Patrol Read**, see the Dell OpenManage documentation at Dell.com/support/manuals.

Physical disk failure detection

Failed physical disks are detected and rebuilds automatically start to new disks that are inserted into the same slot. Automatic rebuilds can also occur with hot spares. If you have configured hot spares, the controllers automatically try to use them to rebuild failed physical disks.

Using persistent hot spare slots

NOTE: The persistent hot spare slot feature is disabled by default.

The PERC 10 series can be configured so that the system backplane or storage enclosure disk slots are dedicated as hot spare slots. This feature can be enabled using the Dell OpenManage storage management application.

Once enabled, any slots with hot spares configured automatically become persistent hot spare slots. If a hot spare disk fails or is removed, a replacement disk that is inserted into the same slot automatically becomes a hot spare with the same properties as the one it is replacing. If the replacement disk does not match the disk protocol and technology, it does not become a hot spare.

For more information on persistent hot spares, see the Dell OpenManage documentation at Dell.com/support/manuals.

Physical disk hot swapping

NOTE: To check if the backplane supports hot swapping, see the Owner's Manual of your system.

Hot swapping is the manual replacement of a disk while the PERC 10 series cards are online and performing their normal functions. The following requirements must be met before hot swapping a physical disk:

- The system backplane or enclosure must support hot swapping for the PERC 10 series cards to support hot swapping.
- The replacement disk must be of the same protocol and disk technology. For example, only a SAS hard drive can replace a SAS hard drive and only a SATA SSD can replace a SATA SSD.

Using replace member and revertible hot spares

The **Replace Member** functionality allows a previously commissioned hot spare to revert to a usable hot spare. When a disk failure occurs within a virtual disk, an assigned hot spare (dedicated or global) is commissioned and begins rebuilding until the virtual disk is optimal. After the failed disk is replaced (in the same slot) and the rebuild to the hot spare is complete, the controller automatically starts to copy data from the commissioned hot spare to the newly-inserted disk. After the data is copied, the new disk is a part of the virtual disk and the hot spare is reverted to being a ready hot spare. This allows hot spares to remain in specific enclosure slots. While the controller is reverting the hot spare, the virtual disk remains optimal.

NOTE: The controller automatically reverts a hot spare only if the failed disk is replaced with a new disk in the same slot. If the new disk is not placed in the same slot, a manual Replace Member operation can be used to revert a previously commissioned hot spare.

NOTE: A Replace Member operation typically causes a temporary impact to disk performance. Once the operation completes, performance returns to normal.

Controller cache preservation

The controller is capable of preserving its cache in the event of a system power outage or improper system shutdown. The PERC 10 Series controller is attached to a Battery Backup Unit (BBU) that provides backup power during system power loss to preserve the controller's cache data.

Cache Preservation With NVC

The Non-Volatile Cache (NVC) allows controller cache data to be stored indefinitely. If the controller has data in the cache memory during a power outage or improper system shutdown, a small amount of power from the battery is used to transfer the cache data to a non-volatile flash storage where it remains until power is restored and the system is booted.

Recovering cache data

If a system power loss or improper system shutdown has occurred:

- 1 Restore the system power.
- 2 Boot the system.
- 3 To enter the **HII Configuration Utility**, select **Managed Preserved Cache** in the controller menu. For more information, see [Entering the HII configuration utility](#).

If there are no virtual disks listed, all preserved cache data has been written to the disk successfully.

Battery Transparent Learn Cycle

A transparent learn cycle is a periodic operation that calculates the charge that is remaining in the battery to ensure there is sufficient energy. The operation runs automatically, and causes no impact to the system or controller performance.

The controller automatically performs the Transparent Learn Cycle (TLC) on the battery to calibrate and gauge its charge capacity once every 90 days. The operation can be performed manually, if required.

NOTE: Virtual disks stay in Write Back mode, if enabled, during transparent learn cycle. When the TLC completes, the controller sets the next TLC to +90 days.

TLC time frame

The time frame for completion of a learn cycle is a function of the battery charge capacity and the discharge and charge currents used.

Conditions for replacing the battery

The PERC battery is marked **Failed** when the state or health of the battery is declared bad. If battery is declared failed then the firmware runs learn cycles in subsequent reboots until the battery is replaced. The virtual disk then transitions to **Write Back** mode.

Deploying the PERC card

This document provides a set of high-level installation and removal instructions for the following Dell PowerEdge RAID Controllers (PERC) 10 series:

- 1 PERC H740P Adapter
- 2 PERC H740P Mini Monolithic
- 3 PERC H840 Adapter

NOTE: For detailed information on cabling the PERC 10 cards, see the system documentation at Dell.com/poweredge manuals.

Topics:

- [Removing the PERC H740P adapter](#)
- [Installing the PERC H740P adapter](#)
- [Removing the PERC H740P mini monolithic](#)
- [Installing the PERC H740P mini monolithic](#)
- [Removing the PERC H840 card](#)
- [Installing the PERC H840 card](#)

Removing the PERC H740P adapter

CAUTION: Many repairs may only be done by a certified service technician. You should only perform troubleshooting and simple repairs as authorized in your product documentation, or as directed by the online or telephone service and support team. Damage due to servicing that is not authorized by Dell is not covered by your warranty. Read and follow the safety instructions that are shipped with your product.

- 1 Turn off the system, including any attached peripherals, and disconnect the system from the electrical outlet and peripherals.

NOTE: It is recommended that you always use a static mat and static strap while working on components in the interior of the system.

- 2 Open the system.
- 3 Locate the PERC card on the system board.

CAUTION: To prevent damage to the card, you must hold the card by its edges only.

- 4 Lift the card to remove it from the connector on the system board.
- 5 Disconnect the SAS cables connected to the card:
 - a Press down and hold the metal tab on the SAS cable connector.
 - b Pull the SAS cable out of the connector.
- 6 Replace the storage controller card and connect the cable. For more information on installing the card, see [Installing the PERC H740P adapter](#).
- 7 Close the system.
- 8 Reconnect the system to its electrical outlet and turn the system on, including any attached peripherals.

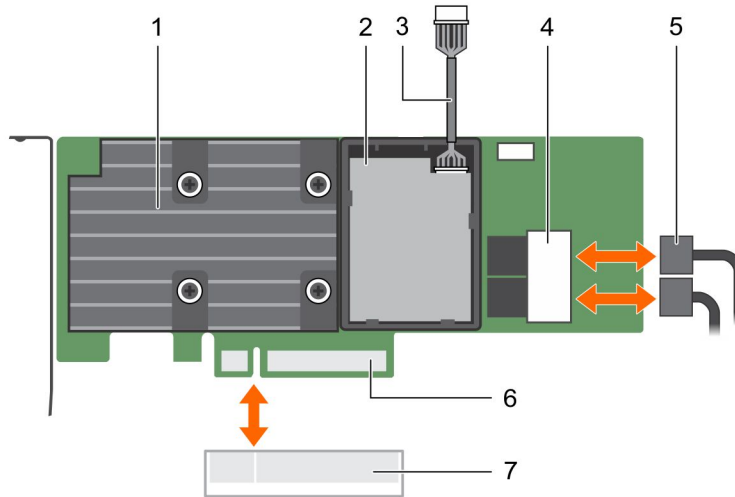

Figure 7. Removing and installing the PERC H740P Adapter

- | | | | |
|---|------------------------------------|---|--------------------------|
| 1 | PERC H740P adapter | 2 | battery |
| 3 | battery cable | 4 | SAS cable connectors (2) |
| 5 | SAS cables (2) | 6 | PERC card connector |
| 7 | card connector on the system board | | |

Installing the PERC H740P adapter

CAUTION: Many repairs may only be done by a certified service technician. You should only perform troubleshooting and simple repairs as authorized in your product documentation, or as directed by the online or telephone service and support team. Damage due to servicing that is not authorized by Dell is not covered by your warranty. Read and follow the safety instructions that are shipped with your product.

- Turn off the system, including any attached peripherals, and disconnect the system from the electrical outlet.

NOTE: It is recommended that you always use a static mat and static strap while working on components in the interior of the system.

- Open the system.
- Align the card-edge connector with the connector on the system board.
To prevent damage to the card, you must hold the card by its edges only.
- Press the card-edge down until the card is fully seated.
- Align the PERC card connector with the card connector on the system board and push the PERC card towards the connector to seat it firmly.
- Connect the SAS data cable connectors to the card.

NOTE: Ensure that you connect the cable according to the connector labels on the cable. The cable does not function properly if reversed.

- Route the SAS data cable through the clip on the card and through the channel on the inner side of the chassis.
- Attach the connector labeled "SAS A" to connector SAS A on the backplane, and attach the connector labeled "SAS B" to connector SAS B on the backplane.
- Close the system.
- Reconnect the system to its electrical outlet and turn the system on, including any attached peripherals.

Removing the PERC H740P mini monolithic

⚠ CAUTION: Many repairs may only be done by a certified service technician. You should only perform troubleshooting and simple repairs as authorized in your product documentation, or as directed by the online or telephone service and support team. Damage due to servicing that is not authorized by Dell is not covered by your warranty. Read and follow the safety instructions that are shipped with your product.

1 Turn off the system, including any attached peripherals, and disconnect the system from the electrical outlet and peripherals.

ⓘ NOTE: It is recommended that you always use a static mat and static strap while working on components in the interior of the system.

2 Open the system.

3 Locate the PERC card on the system board.

⚠ CAUTION: To prevent damage to the card, you must hold the card by its edges only.

4 Loosen the screws that secure the controller cable to the card connector on the system board.

5 Lift the controller cable away from the card.

6 Lift one end of the card and angle it to disengage the card from the card holder on the system board.

7 Lift the card out of the system.

8 Close the system.

9 Reconnect the system to its electrical outlet and turn the system on, including any attached peripherals.

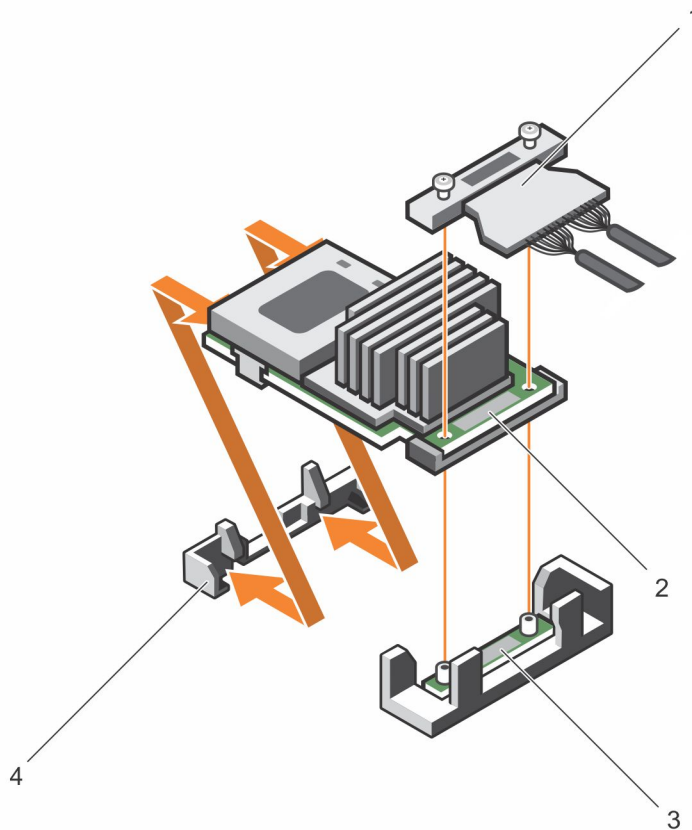

Figure 8. Removing and installing the PERC H740P mini monolithic card

- | | | | |
|---|------------------------------------|---|---------------------------------|
| 1 | cable | 2 | PERC H740P mini monolithic card |
| 3 | card connector on the system board | 4 | card holder |

Installing the PERC H740P mini monolithic

CAUTION: Many repairs may only be done by a certified service technician. You should only perform troubleshooting and simple repairs as authorized in your product documentation, or as directed by the online or telephone service and support team. Damage due to servicing that is not authorized by Dell is not covered by your warranty. Read and follow the safety instructions that are shipped with your product.

1 Turn off the system, including any attached peripherals, and disconnect the system from the electrical outlet.

NOTE: It is recommended that you always use a static mat and static strap while working on components in the interior of the system.

2 Open the system.

3 Align the end of the card with the card connector on the system board.

4 Lower the connector side of the card into the card connector on the system board.

NOTE: Ensure that the tabs on the system board align with the screw holes on the card.

5 Align the screws on the card cable with the screw holes on the connector.

6 Tighten the screws to secure the card cable with the card connector on the system board.

7 Close the system.

- 8 Reconnect the system to its electrical outlet and turn the system on, including any attached peripherals.

Removing the PERC H840 card

CAUTION: Many repairs may only be done by a certified service technician. You should only perform troubleshooting and simple repairs as authorized in your product documentation, or as directed by the online or telephone service and support team. Damage due to servicing that is not authorized by Dell is not covered by your warranty. Read and follow the safety instructions that are shipped with your product.

- 1 Turn off the system, including any attached peripherals, and disconnect the system from the electrical outlet and peripherals.

NOTE: It is recommended that you always use a static mat and static strap while working on components in the interior of the system.

- 2 Open the system.

- 3 Locate the PERC card on the system board.

CAUTION: To prevent damage to the card, you must hold the card by its edges only.

- 4 Disconnect the SAS cables connected to the card:

- a Press down and hold the metal tab on the SAS cable connector.
- b Pull the SAS cable out of the connector.

- 5 Lift the card to remove it from the connector on the system board.

- 6 Replace the storage controller card and connect the cable. For more information on installing the card, see [Installing the PERC H840 card](#).

- 7 Close the system.

- 8 Reconnect the system to its electrical outlet and turn the system on, including any attached peripherals.

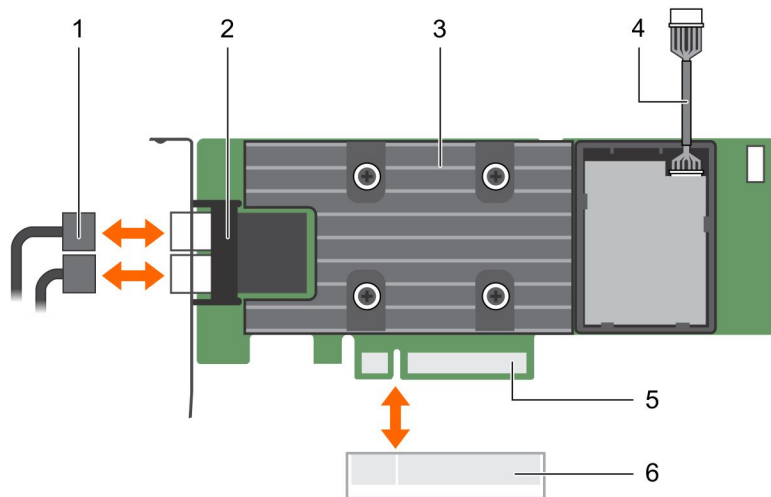

Figure 9. Removing and installing the PERC H840 adapter

- | | |
|-----------------------|--------------------------------------|
| 1 SAS cables (2) | 2 SAS cable connectors (2) |
| 3 PERC H840 adapter | 4 battery |
| 5 PERC card connector | 6 card connector on the system board |

Installing the PERC H840 card

⚠ CAUTION: Many repairs may only be done by a certified service technician. You should only perform troubleshooting and simple repairs as authorized in your product documentation, or as directed by the online or telephone service and support team. Damage due to servicing that is not authorized by Dell is not covered by your warranty. Read and follow the safety instructions that are shipped with your product.

1 Turn off the system, including any attached peripherals, and disconnect the system from the electrical outlet.

① NOTE: It is recommended that you always use a static mat and static strap while working on components in the interior of the system.

2 Open the system.

3 Align the card-edge connector with the connector on the system board.

To prevent damage to the card, you must hold the card by its edges only.

4 Press the card-edge down until the card is fully seated.

5 Align the PERC card connector with the card connector on the system board and push the PERC card towards the connector to seat it firmly.

6 Connect the SAS data cable connectors to the card.

① NOTE: Ensure that you connect the cable according to the connector labels on the cable. The cable does not function properly if reversed.

7 Close the system.

8 Reconnect the system to its electrical outlet and turn the system on, including any attached peripherals.

Driver installation

The Dell PowerEdge RAID Controller (PERC) 10 series of cards require software drivers to operate with the supported operating systems. This chapter contains the procedures for installing the drivers for the PERC 10 cards.

NOTE: The drivers for PERC 10 for VMware ESXi is packaged within the VMware ESXi ISO image downloaded from Dell. For more information, see the VMware documentation at Dell.com/virtualizationsolutions. It is not recommended to have drivers from controllers prior to PERC 10 on the same system.

The two methods for installing a driver discussed in this chapter are:

- **Installing a driver during operating system installation:** Use this method if you are performing a new installation of the operating system and want to include the drivers.
- **Updating existing drivers:** Use this method if the operating system and the PERC 10 family of controllers are already installed and you want to update to the latest drivers.

Topics:

- [Creating the device driver media](#)
- [Windows driver installation](#)
- [Installing the driver during a Windows Server 2012 R2 and newer installation](#)
- [Installing the driver after Windows Server 2012 R2 and newer installation](#)
- [Updating PERC 10 driver for existing Windows Server 2012 R2 and newer](#)
- [Linux driver installation](#)

Creating the device driver media

Use one of the following two methods to create the device driver media:

- [Downloading Drivers From The Dell Systems Service And Diagnostic Tools Media](#)
- [Downloading Drivers From The Dell Support Website](#)

Downloading drivers from the Dell support website

To download drivers from the Dell Support website:

- 1 Go to **Dell.com/support**.
- 2 Enter the service tag of your system in the **Choose by Service Tag to get started** field or select **Choose from a list of all Dell products**.
- 3 Select the **System Type**, **Operating System**, and **Category** from the drop-down list.
The drivers that are applicable to your selection are displayed.
- 4 Download the drivers that you require to a USB drive, CD, or DVD.
- 5 During the operating system installation, use the media that you created with the **Load Driver** option to load mass storage drivers. For more information on reinstalling the operating system, see the relevant section for your operating system below.

Downloading drivers from the Dell systems service and diagnostic tools media

To download drivers from the *Dell Systems Service and Diagnostic Tools* media:

- 1 Insert the *Dell Systems Service and Diagnostics Tools* media in your system.
The **Welcome to Dell Service and Diagnostic Utilities** screen is displayed.
- 2 Select your system model and operating system.
- 3 Click **Continue**.
- 4 From the list of drivers displayed, select the driver you require.
- 5 Select the self-extracting zip file and click **Run**.
- 6 Copy the driver to a CD, DVD, or USB drive.
- 7 Repeat this procedure for all the drivers you require.

Windows driver installation

Before you install the Windows driver for PERC 10, you must first create a device driver media.

- Read the Microsoft *Getting Started* document that shipped with your operating system.
- Ensure that your system has the latest BIOS, firmware, and driver updates. If required, download the latest BIOS, firmware, and driver updates from **Dell.com/support**.
- Create a device driver media using one of the methods listed below:
 - USB drive
 - CD
 - DVD

Installing the driver during a Windows Server 2012 R2 and newer installation

To install the driver:

- 1 Boot the system using the Windows Server 2012 R2, or newer media.
- 2 Follow the on-screen instructions until you reach **Where do you want to install Windows Server 2012 R2 or newer** window and then select **Load driver**.
- 3 The system prompts you to insert the media. Insert the installation media and browse to the appropriate location.
- 4 Select a PERC 10 series card from the list.
- 5 Click **Next** and continue installation.

Installing the driver after Windows Server 2012 R2 and newer installation

Perform the following steps to configure the driver for the RAID controller on a system that already has Windows installed:

- 1 Turn off the system.
- 2 Install the new RAID controller in the system.
For detailed instructions on installing the RAID controller in the system, see [Deploying the PERC card](#).
- 3 Turn on the system.

The **Found New Hardware Wizard** screen displays the detected hardware device.

- 4 Click **Next**.
- 5 On the **Locate device driver** screen, select **Search for a suitable driver for my device** and click **Next**.
- 6 Browse and select the drivers from the **Locate Driver Files** screen.
- 7 Click **Next**.

The wizard detects and installs the appropriate device drivers for the new RAID controller.

- 8 Click **Finish** to complete the installation.
- 9 Reboot the system when prompted.

Updating PERC 10 driver for existing Windows Server 2012 R2 and newer

NOTE: Close all applications on your system before you update the driver.

- 1 Insert the media (CD, DVD, or USB drive) containing the driver.
- 2 Select **Start > Settings > Control Panel > System**.
The **System Properties** screen is displayed.

NOTE: The path to **System** might vary depending on the operating system family.

- 3 Click on the **Hardware** tab.
- 4 Click **Device Manager**.

The **Device Manager** screen is displayed.

NOTE: The path to **Device Manager** might vary depending on the operating system family.

- 5 Expand **SCSI and RAID Controllers** by double-clicking the entry or by clicking on the plus symbol next to **SCSI and RAID Controller**.

NOTE: In Windows Server 2012 R2, the PERC 10 series of cards are listed under **Storage Controllers**.

- 6 Double-click the RAID controller for which you want to update the driver.
- 7 Click the **Driver** tab and click **Update Driver**.
The screen to update the device driver wizard is displayed.
- 8 Select **Install from a list or specific location**.
- 9 Click **Next**.
- 10 Follow the steps in the wizard and browse to the location of the driver files.
- 11 Select the INF file from the driver media (CD, DVD, or other media).
- 12 Click **Next** and continue the installation steps in the wizard.
- 13 Click **Finish** to exit the wizard and reboot the system for the changes to take place.

NOTE: Dell provides the Dell Update Package (DUP) to update drivers on systems running Windows Server 2012 R2 and newer operating system. DUP is an executable application that updates drivers for specific devices. DUP supports command line interface and silent execution. For more information, see Dell.com/support.

Linux driver installation

NOTE: PERC 10 series of drivers support PERC 9 family controllers and do not require separate driver installations.

NOTE: The driver update disk (DUD) images are created only for those operating system releases in which the native (in-box) driver is insufficient for installation. In the event that an operating system is being installed with a corresponding DUD image, follow the instructions below.

NOTE: To view the complete list of boot loader options, see the installation guide of your operating system.

Installing or updating the RPM driver package with KMOD support

NOTE: This procedure is applicable for Red Hat Enterprise Linux 7.3.

Perform the following steps to install the RPM package with KMOD support:

- 1 Uncompress the gzipped tarball driver release package.
- 2 Install the driver package using the command: `rpm -ihv kmodmegaraid_ sas-<version>.rpm`.

NOTE: Use `rpm -Uvh <package name>` when upgrading an existing package.

- 3 If the previous device driver is in use, you must reboot the system for the updated driver to take effect.
- 4 Verify that the driver is loaded with the following system commands: `modinfo megaraid_sas`.

Installing or updating the RPM driver package with KMP support

NOTE: This procedure is applicable for SUSE Enterprise Linux 12.2.

Perform the following steps to install the RPM package with KMP support:

- 1 Uncompress the gzipped tarball driver release package.
- 2 Install the driver package using the command: `rpm -ihv kmpmegaraid_ sas- <version>.rpm`.

NOTE: Use `rpm -Uvh <package name>` when updating an existing package.

- 3 If the previous device driver is in use, you must reboot the system for the updated driver to take effect.
- 4 Verify that the driver is loaded with the following system commands: `modinfo megaraid_sas`.

Loading the driver during operating system installation

- 1 Navigate to the installer.
- 2 In the Installation screen, press E.
- 3 Perform the following operation:
 - If the operating system is RHEL, the CLI displays the syntax `quiet`. Enter `inst.dd`.
For example, when you are prompted with the command `linuxefi/images/pxeboot/vmlinuz inst.stage2=hd:LABEL=RHEL-7.3\x20Server.x86_64` `quiet`, enter `inst.dd`.
 - If the operating system is SLES, the CLI displays the syntax `silent`. Enter `dud=1`.
For example, when you are prompted with the command `linuxefi/boot/x86_64/loader/linux splash=silent dud=1`, enter `dud=1`.
- 4 Attach the driver media.
- 5 Press F10 to boot to the OS.
A screen is displayed prompting you to select the driver media (USB, CD, ISO, and so on).
- 6 Select the driver.

NOTE: Ensure that the driver is selected with an X.

- 7 Press C to load the driver.
- 8 Disconnect the driver media.

 **NOTE:** Ensure that you disconnect the driver media so that the drivers are loaded successfully.

- 9 Press C or exit to continue with the installation.

Firmware

This section provides information about downloading and installing the firmware using Dell Update Package (DUP).

Installing the firmware using DUP

- 1 Navigate to **Dell.com/support**.
- 2 Locate your controller.
- 3 Download the DUP.
 - a For Window/iDRAC update, download Windows executable file.
 - b For Linux update, download `.bin` file.
- 4 Install the DUP.
 - a For Windows, run the executable in Windows environment.
 - b For Linux, run `.bin` file in Linux environment.
 - c For iDRAC, navigate to **system iDRAC > Maintenance > System Update**, upload Windows executable, and then install.

HII configuration utility

The Human Interface Infrastructure (HII) configuration utility is a storage management application integrated into the System BIOS <F2>. It is used to configure and manage RAID disk groups, virtual disks, and physical disks. This utility is independent of the operating system.

Topics:

- [Entering the HII configuration utility](#)
- [Exiting the HII configuration utility](#)
- [Navigating to Dell PERC 10 configuration utility](#)
- [HII Configuration utility Dashboard View options](#)
- [Configuration management](#)
- [Controller management](#)
- [Virtual disk management](#)
- [Physical disk management](#)
- [Hardware components](#)

Entering the HII configuration utility

Perform the following steps to boot to the HII configuration utility:

- 1 Turn on the system.
- 2 While the system startup, press <F2> to enter **System Setup**.
Displays the list of menu in the **System Setup Main Menu** screen.
- 3 Click **Device Settings**.
Device Settings screen lists all the RAID controllers in the system.
To access the management menu for the controller, use the arrow keys or the mouse.

NOTE: For more information in all the options, click **Help** that is available on the top right-hand corner of the browser screen. Help information for individual option menus can also be viewed by scrolling down on each option.

NOTE: Some of the options within the HII configuration utility are not present if the controller does not support the corresponding feature. Options may also be grayed out if the feature is supported in existing configuration.

Exiting the HII configuration utility

To exit the HII configuration utility, perform the following steps:

- 1 Click **Finish** at the bottom-right corner on the **System Setup Main Menu** screen.
Displays a warning message to confirm your choice.
- 2 Click **Yes** to exit the HII configuration utility.

Navigating to Dell PERC 10 configuration utility

- 1 Enter the UEFI configuration Utility. See [Entering the HII configuration utility](#).

The **Device Settings** screen displays a list of NIC ports and the Dell PERC 10 configuration utility.

- 2 To enter PERC 10 configuration utility, click **Dell PERC 10 Configuration Utility**.

The **Dashboard view** screen is displayed.

HII Configuration utility Dashboard View options

The first screen that is displayed when you access the HII Configuration Utility is the **Dashboard View** screen. The following table provides detailed information about the options available on the **Dashboard View** screen.

Table 5. Dashboard View screen

Dashboard View options	Description
Main Menu	Displays the following configuration options: <ul style="list-style-type: none">• Configuration Management• Controller Management• Virtual Disk Management• Physical Disk Management• Hardware Components
Help	Provides context sensitive help message.
Properties	Displays the following information about the controller: <ul style="list-style-type: none">• Status — displays the status of the controller.• Backplane — displays information about the number of backplanes connected to the controller.• BBU — displays information about the availability of Battery Backup Unit (BBU).• Enclosure — displays information about the number of enclosures connected to the controller.• Physical Disks — displays information about the number of physical disks connected to the controller.• Disk Groups — displays information about the number of disk groups connected to the controller.• Virtual Disks — displays information about the number of virtual disks connected to the controller.
View Server Profile	Displays HII Spec version supported on the system and also displays the following menu options for controller components: <ul style="list-style-type: none">• Controller Management• Hardware Components• Physical Disk Management• Virtual Disk Management
Actions	Displays the following options: <ul style="list-style-type: none">• Configure — displays configuration options that are supported by the controller.• Set Factory Defaults — restore factory default values for all controller properties.
Background Operations	Displays if virtual disk or physical disk operations are in progress.

Configuration management

Creating the virtual disks

- 1 Enter the **Dell PERC 10 Configuration Utility**. See [Navigating to Dell PERC 10 configuration utility](#).
- 2 Click **Main Menu > Configuration Management > Create Virtual Disk**.

The following list of options are displayed for you to define the virtual disk parameters:

- Select RAID level — allows you to choose the RAID level of your choice.
- Secure Virtual Disk — If you want to create a secured virtual disk, select **Secure Virtual Disk**.

NOTE: The Secure Virtual Disk option is enabled and selected by default, only if the security key has been configured. Only SED physical disks are listed.

- Select Physical Disks From — allows you to select one of the physical disk capacities:
 - **Unconfigured Capacity:** creates a virtual disk on unconfigured physical disks.
 - **Free Capacity:** utilizes unused physical disk capacity that is already part of a virtual disk.
 - Select Physical Disks — If you want to select the physical disks from which the virtual disks are being created, click **Select Physical Disks**. This option is displayed if you select **Unconfigured Capacity** as your physical disk capacity.
 - Select Disk Groups — If you want to select the disk groups from which the virtual disks are being created, click **Select Disk Group**. This option is displayed if you select **Free Capacity** as your physical disk capacity.
 - Configure Virtual Disk Parameters — allows you to set the virtual disk parameters when creating the virtual disk. For more information, see [Configuring virtual disk parameters](#).
- 3 Click **Create Virtual Disk**.

The virtual disk is created successfully.

Configuring virtual disk parameters

- 1 Create a virtual disk, see [Creating the virtual disks](#).
The **CONFIGURE VIRTUAL DISK PARAMETERS** section is displayed on the **Create Virtual Disk** screen.
- 2 In the **CONFIGURE VIRTUAL DISK PARAMETERS** section, you can set the following virtual disk parameters:

Table 6. Configuring virtual disk parameters

Virtual Disk Name	allows you to enter the name for the virtual disk. NOTE: Allowed characters are A-Z, a-z, 0-9, underscore (_), and hyphen (-) only.
Virtual Disk Size	displays the maximum capacity available for the virtual disk.
Virtual Disk Size Unit	displays the virtual disk storage space in megabytes, gigabytes, and terabytes.
Strip Element Size	allows you to select the strip element size. The disk striping involves partitioning each physical disk storage space in stripes of the following sizes: 64 KB, 128 KB, 256 KB, 512 KB, and 1 MB. By default, the strip element size is set to 256 KB.
Read Policy	displays the controller read policy. You can set the read policy to: <ul style="list-style-type: none">• No Read Ahead — specifies that the controller does not use read ahead for the current virtual disk.

- **Read Ahead** — specifies that the controller uses Read-Ahead for the current virtual disk. Read-Ahead capability allows the controller to read sequentially ahead of requested data and store the additional data in the cache memory, anticipating that the data is required soon.

By default, the read cache policy is set to Read Ahead.

displays the controller write cache policy. You can set the write policy to:

- **Write through** — the controller sends a data transfer completion signal to the host when the disk subsystem has received all the data in a transaction.
- **Write back** — the controller sends a data transfer completion signal to the host when the controller cache has received all the data in a transaction.

By default, the write policy is set to Write Back.

Write Policy

Disk Cache

allows you to set the disk cache policy to Default, Enable, or Disable.

By default, the disk cache is set to Default.

Default Initialization

displays the virtual disk initialization options. You can set the **Default Initialization** to:

- **No** — The virtual disk is not initialized.
- **Fast** — The first 8 MB of the virtual disk is initialized.
- **Full** — The entire virtual disk is initialized.

For more information, see [Virtual disk initialization](#).

By default, the default initialization is set to No.

Creating profile based virtual disk

- 1 Enter the **Dell PERC 10 Configuration Utility**. See [Navigating to Dell PERC 10 configuration utility](#).
- 2 Click **Main Menu > Configuration Management > Creating Profile Based Virtual Disk**.

The following list of RAID modes are displayed:

- Generic RAID 0
- Generic RAID 1
- Generic RAID 5
- Generic RAID 6
- File Server
- Web/Generic Server
- Database

- 3 Based on the RAID mode selected, one or more the physical disk selection criteria is displayed.
- 4 From the **Physical Disk Selection Criteria** drop-down box, select a criteria based your requirement. The Profile Parameters of the selected option is displayed.
- 5 Click **Create Virtual Disk**.
- 6 Select **Confirm** and click **Yes** to continue.

The virtual disk is created with the parameters of the profile selected.

Viewing Disk Group Properties

- 1 Enter the **Dell PERC 10 Configuration Utility**. See [Navigating to Dell PERC 10 configuration utility](#).
- 2 Click **Main Menu > Configuration Management > View Disk Group Properties**.

The list of Disk Group # properties are displayed:

- Capacity Allocation — displays all the virtual disks associated with the specific disk group. It also provides information about the available free space.
- Secured — displays whether the disk group is secured or not.

Deleting Configurations

- 1 Enter the **Dell PERC 10 Configuration Utility**. See [Navigating to Dell PERC 10 configuration utility](#).
- 2 Click **Main Menu > Configuration Management > Clear Configuration**.

A screen is displayed asking if you are sure you want to perform the operation.

- 3 Select **Confirm** and click **Yes** to continue.

The virtual disks and hot spare disks available on the controller are deleted successfully.

Controller management

Clearing controller events

- 1 Enter the **Dell PERC 10 Configuration Utility**. See [Navigating to Dell PERC 10 configuration utility](#).
- 2 Click **Main Menu > Controller Management > Advanced Controller Management**.
- 3 Click **Clear Controller Events**.

A screen is displayed indicating that the operation is completed successfully.

- 4 Click **Ok**.

Saving controller events

- 1 Enter the **Dell PERC 10 Configuration Utility**. See [Navigating to Dell PERC 10 configuration utility](#).
- 2 Click **Main Menu > Controller Management > Advanced Controller Management**.
- 3 Click **Save Controller Events**.

A screen is displayed indicating that the operation is completed successfully.

- 4 Click **Ok**.

Saving debug log

- 1 Enter the **Dell PERC 10 Configuration Utility**. See [Navigating to Dell PERC 10 configuration utility](#).
- 2 Click **Main Menu > Controller Management > Advanced Controller Management**.
- 3 Click **Save Debug Log**.

A screen is displayed indicating that the operation is completed successfully.

- 4 Click **Ok**.

Managing link speed

- 1 Enter the **Dell PERC 10 Configuration Utility**. See [Navigating to Dell PERC 10 configuration utility](#).
- 2 Click **Main Menu > Controller Management > Advanced Controller Management**.
- 3 Click **Manage Link Speed**.

You can view/change the physical disk settings for the controller, if required. The possible options are:

- Auto
- 3 Gbps
- 6 Gbps
- 12 Gbps

- 4 Click **Ok** to save the changes.

NOTE: To reflect the changes, perform an AC power cycle that is disconnecting and reconnecting the power source.

Restoring factory default settings

- 1 Enter the **Dell PERC 10 Configuration Utility**. See [Navigating to Dell PERC 10 configuration utility](#).
- 2 Click **Main Menu > Set Factory Defaults**.
A screen is displayed asking you to confirm the operation.
- 3 Select **Confirm** and click **Yes** to continue.

Advanced controller properties

Clearing the cache memory

- 1 Enter the **Dell PERC 10 Configuration Utility**. See [Navigating to Dell PERC 10 configuration utility](#).
- 2 Click **Main Menu > Controller Management > Advanced Controller Properties**.
- 3 Click **Cache and Memory > Discard Preserved Cache**.
The preserved cache is cleared successfully.

Setting patrol read

- 1 Enter the **Dell PERC 10 Configuration Utility**. See [Navigating to Dell PERC 10 configuration utility](#).
- 2 Click **Main Menu > Controller Management > Advanced Controller Properties**.
- 3 Click **Patrol Read**.
The following options are displayed:
 - **Start** — Starts patrol read for the selected controller.
 - **Suspend** — Suspends the ongoing patrol read operation on the controller.
 - **Resume** — Resumes the suspended patrol read operation.
 - **Stop** — Stops patrol read for the selected controller.
- 4 Set the **Mode** to **Auto**, **Manual**, or **Disabled**.
- 5 Click **Apply Changes**.

Enabling physical disk power management

- 1 Enter the **Dell PERC 10 Configuration Utility**. See [Navigating to Dell PERC 10 configuration utility](#).
- 2 Click **Main Menu > Controller Management > Advanced Controller Properties**.
- 3 Click **Physical Disk Power Management**.

The following list of options are displayed:

- Power Saving mode — allows the user to specify the physical disk power saving mode. The possible available options are:
 - No Power Savings
 - Balanced Power Savings
 - Maximum Power Savings
 - Customized Power Savings
 - Configured Spin Down Delay — allows the user to specify the delay time before a configured disk is spun down.
 - Spin Down Hot Spare — allows you to enable or disable the spin down of hot spare disks.
 - Spin Down Unconfigured Good — spin down of un-configured disks.
 - Automatic Disk Power Savings — allows the user to enable or disable the idle-C timer. When Idle-C is enabled, all disks in the system that are idle-C compliant will have Idle-C enabled, based on the power saving mode.
 - QoS Window — allows the user to enable or disable the quality of service window for configured disks.
 - QoS Window Start Time — allows the user to specify the QoS windows start time.
 - QoS Windows End Time — allows the user to specify the QoS windows end time.
- 4 Select the applicable options and click **Apply Changes**.

The changes made are saved successfully.

Configuring hot spare

- 1 Enter the **Dell PERC 10 Configuration Utility**. See [Navigating to Dell PERC 10 configuration utility](#).
- 2 Click **Main Menu > Controller Management > Advanced Controller Properties**.
- 3 Click **Spare**.

The following list of options are displayed:

- Persistent Hot Spare — allows you to enable or disable the ability to have same system backplane or storage enclosure disk slots dedicated as hot spare slots.
 - Allow Replace Member with Revertible Hot Spare — allows you to enable or disable the option to copy the data form a hot spare disk to physical disk.
 - Auto Replace Member on Predictive Failure — allows you to enable or disable the option to start a Replace Member operation if a predictive failure error is detected on a physical disk.
- 4 Select the applicable option and click **Apply Changes**.

The changes made are saved successfully.

Setting task rates

- 1 Enter the **Dell PERC 10 Configuration Utility**. See [Navigating to Dell PERC 10 configuration utility](#).
- 2 Click **Main Menu > Controller Management > Advanced Controller Properties**.
- 3 Click **Task Rates**.

The following options are displayed:

- Background Initialization (BGI) Rate
- Consistency Check Rate
- Rebuild Rate

- Reconstruction Rate
- 4 You can make the necessary changes and then click **Apply Changes**.
The task rates operation is completely successfully.

Enabling auto import

- 1 Enter the **Dell PERC 10 Configuration Utility**. See [Navigating to Dell PERC 10 configuration utility](#).
- 2 Click **Main Menu > Controller Management > Advanced Controller Properties**.
- 3 In the **Controller Properties** section, set the **Auto Import Foreign Configuration** option to **Enabled**.
- 4 Click **Apply Changes**.
The auto import is enabled successfully.

Disabling auto import

- 1 Enter the **Dell PERC 10 Configuration Utility**. See [Navigating to Dell PERC 10 configuration utility](#).
- 2 Click **Main Menu > Controller Management > Advanced Controller Properties**.
- 3 In the **Controller Properties** section, set the **Auto Import Foreign Configuration** option to **Disabled**.
- 4 Click **Apply Changes**.
The auto import is disabled successfully.

Selecting the boot mode

- 1 Enter the **Dell PERC 10 Configuration Utility**. See [Navigating to Dell PERC 10 configuration utility](#).
- 2 Click **Main Menu > Controller Management > Advanced Controller Properties**.
- 3 In the **CONTROLLER PROPERTIES** section, select the boot mode from the **Boot Mode** drop-down box.
The following list of boot mode options are displayed:
 - Stop on errors
 - Pause on errors
 - Ignore errors
 - Safe mode on errors

NOTE: Note: By default, the boot mode option is set to Pause on errors.

- 4 Click **Apply Changes**.
The boot mode operation is completed successfully.

Aborting the consistency check

- 1 Enter the **Dell PERC 10 Configuration Utility**. See [Navigating to Dell PERC 10 configuration utility](#).
- 2 Click **Main Menu > Controller Management > Advanced Controller Properties**.
- 3 In the **Controller Properties** section, set the **Abort Consistency Check on Error** option to **Enabled**.
- 4 Click **Apply Changes**.
The option to abort the consistency check operation on a redundant virtual disk is enabled, if there is any inconsistency found in the data.

Enabling boot support

- 1 Enter the **Dell PERC 10 Configuration Utility**. See [Navigating to Dell PERC 10 configuration utility](#).
- 2 Click **Main Menu > Controller Management**.
- 3 From the **Select Boot Device** drop-down box, select the primary bootable device.

① **NOTE:** You cannot view the 4K drives option. The 4K boot support is only available in UEFI mode and managed by the Boot loader.

① **NOTE:** In **Select Boot Device**, you may not be able to view all the virtual disks that you have created. To view all the virtual disks created, navigate to **Virtual Disk Management** screen in HII. For more information, see the section [Virtual disk management](#).

- 4 Click **Apply Changes**.
The boot support is enabled for the selected controller.

Enabling large I/O support

- 1 Enter the **Dell PERC 10 Configuration Utility**. See [Navigating to Dell PERC 10 configuration utility](#).
- 2 Click **Main Menu > Controller Management > Advanced Controller Properties**.
- 3 In the **Controller Properties** section, set the **Large IO Support** option to **Enabled**.
- 4 Click **Apply Changes**.

The changes made are saved successfully.

Virtual disk management

Viewing virtual disk properties

- 1 Enter the **Dell PERC 10 Configuration Utility**. See [Navigating to Dell PERC 10 configuration utility](#).
- 2 Click **Main Menu > Virtual Disk Management**.
All the virtual disks associated with the RAID controller are displayed.
- 3 To view the properties, click on the virtual disk. You can view the following properties of the Virtual disk:

Option	Description
Operation	Displays the lists of operations you can perform on the selected virtual disk. The options are: <ul style="list-style-type: none">• Blink• Unblink• Delete Virtual Disk• Reconfigure Virtual Disks• Fast Initialization• Slow Initialization• Secure Virtual Disk
	① NOTE: The Secure Virtual Disk option is enabled only for the SED physical disks by default, only if the security key has been configured.
	<ul style="list-style-type: none">• Break Mirror• Expand Virtual Disk• Consistency Check

Option	Description
Name	Indicates the name of the virtual disk.
Status Property	Indicates the status of the virtual disk. The possible options are: <ul style="list-style-type: none"> • Optimal • Degraded • Offline • Failed
RAID level	Indicates the RAID level of the virtual disk.
Size	Indicates the size of the virtual disk.

- 4 Click **Advanced...**
You can view the following additional properties of the virtual disk:

Table 7. Advanced properties of the virtual disk

Option	Description
Logical Sector Size	Indicates the logical sector size of this virtual disk.
Strip Element Size	Indicates the strip element size for the virtual disk.
Status	Indicates the status of the virtual disk.
Secured	Indicates whether the virtual disk is secured or not.
Bad Blocks	Indicates whether the virtual disk has corrupted blocks.

Viewing physical disks associated with a virtual disk

- 1 Enter the **Dell PERC 10 Configuration Utility**. See [Navigating to Dell PERC 10 configuration utility](#).
- 2 Click **Main Menu > Virtual Disk Management**.
All the virtual disks associated with the RAID controller are displayed.
- 3 Click on a virtual disk.
The properties of the virtual disk are displayed.
- 4 Click **View Associated Physical Disks**.
All the physical disks that are associated with the virtual disk are displayed.
- 5 From the **Associated Physical Disks** section, select the physical disk.
- 6 Click **View Physical Disk Properties** to view the physical disk properties.

Configuring virtual disk policies

- 1 Enter the **Dell PERC 10 Configuration Utility**. See [Navigating to Dell PERC 10 configuration utility](#).
- 2 Click **Main Menu > Virtual Disk Management**.
All the virtual disks associated with the RAID controller are displayed.
- 3 Click **Advanced...**
You can view the following virtual disk policies:

Table 8. Virtual disk policies

Option	Description
Current write cache	Indicates the current write cache policy for the virtual disk.
Default write cache	Allows you to select the write cache policy for the virtual disk. The possible options are: <ul style="list-style-type: none">• Write Through• Write Back• Force Write Back
Read Cache policy	Allows you to select the read cache policy for the virtual disk. The possible options are: <ul style="list-style-type: none">• No Read Ahead• Read Ahead
Disk Cache	Allows you to select the disk cache policy for the virtual disk. The possible options are: <ul style="list-style-type: none">• Default• Enable• Disable

- 4 Click **Apply Changes**.
The changes made are saved successfully.

Performing break mirror operation

The RAID 1 virtual disk that you wish to split must be in an optimal state, and it cannot be running any other background tasks.

To use the Break Mirror feature from the HII Configuration Utility, perform the following steps:

- 1 Enter the **Dell PERC 10 Configuration Utility**. See [Navigating to Dell PERC 10 configuration utility](#).
- 2 Click **Main Menu > Virtual Disk Management** .
The list of virtual disks are displayed.
- 3 Select the RAID 1 virtual disk.
NOTE: The Break Mirror operation can be performed only on RAID 1 virtual disks.
- 4 From the **Operations** drop-down menu, select **Break Mirror**.
- 5 Click **Go**.
A screen is displayed asking if you are sure you want to perform the operation.
- 6 Select the **Confirm** option.
- 7 Click **Yes**.
The break mirror operation is completed successfully.

Performing expand virtual disk operation

To enable expand virtual disk feature from the HII Configuration Utility, perform the following steps:

- 1 Enter the **Dell PERC 10 Configuration Utility**. See [Navigating to Dell PERC 10 configuration utility](#).
- 2 Click **Main Menu > Virtual Disk Management** .

The list of virtual disks are displayed.

- 3 Select the virtual disk.
- 4 From the **Operations** drop-down menu, select **Expand Virtual Disk**.

NOTE: You can view the **Expand Virtual Disk** feature only if there is free space available in the associated disk group.

- 5 Click **Go**.
- 6 To expand virtual disk, enter the percentage of available capacity, and then click **Ok**.
A screen is displayed asking if you are sure you want to perform the operation.
- 7 Select the **Confirm** option.
- 8 Click **Yes**.
The expand virtual disk operation is completed successfully.

Performing consistency check

To enable consistency check from the HLL Configuration Utility, perform the following steps:

- 1 Enter the **Dell PERC 10 Configuration Utility**. See [Navigating to Dell PERC 10 configuration utility](#).
- 2 Click **Main Menu > Virtual Disk Management**.
The list of virtual disks are displayed.
- 3 Select the virtual disk.

NOTE: You cannot run consistency check on RAID 0 virtual disks.

- 4 From the **Operations** drop-down menu, select **Check Consistency**.
- 5 Click **Go**.
A screen is displayed asking if you are sure you want to perform the operation.
- 6 Select the **Confirm** option.
- 7 Click **Yes**.
The consistency check operation is completed successfully.

Physical disk management

Viewing physical disk properties

- 1 Enter the **Dell PERC 10 Configuration Utility**. See [Navigating to Dell PERC 10 configuration utility](#).
- 2 Click **Main Menu > Physical Disk Management**.
All the physical disks associated with the RAID controller are displayed.
- 3 To view the properties, click on the physical disk. You can view the following properties of the physical disk:

Option	Description
Operation	Displays the lists of operations you can perform on the selected physical disk. The options are: <ul style="list-style-type: none">• Blink• Unblink• Force Offline• Replace Member• Erase Options• Global and Dedicated hotspare
Physical Disk ID	Indicates the unique identifier of the physical disk.

Option	Description
Status	Indicates the status of the physical disk.
Size	Indicates the size of the physical disk.
Type	Indicates the type of the physical disk.
Model	Indicates the model of the physical disk.
Part Number	Indicates the part number of the physical disk.
Serial Number	Indicates the serial of the physical disk.
Manufacturing Date	Indicates the date on which the physical disk has been manufactured
Associated Virtual Disks	Displays the virtual disks associated with the physical disk.

4 Click **Advanced...**

You can view the following additional properties of the physical disk:

Table 9. Advanced physical disk properties

Option	Description
Logical Sector Size	Indicates the logical sector size of the selected physical disk.
Physical Sector Size	Indicates the physical sector size of the selected physical disk.
SMART Status	Indicates the SMART status of a physical disk.
Revision	Indicates the firmware version of the physical disk.
SAS Address	Indicates the SAS address of the physical disk.
Physical Disk Power State	Indicates the power condition (On or Power Save) of the physical disk.
Disk Cache Settings	Indicates the disk cache settings.
Hard Disk Drive RPM	Indicates the RPM of the hard drive.
Available Space	Indicates the available size of the physical disk.
Used Space	Indicates the configured space of the physical disk.
Disk protocol	Indicates the type of hard disk used.
Device Speed	Indicates the speed of the physical disk.
Negotiated Link Speed	Indicates the negotiated link speed of the device.
Encryption Capable	Indicates whether the physical disk is encryption capable or not.
Secured	Indicates whether the physical disk is secured or not.
Cryptographic Erase Capable	Indicates whether the physical disk is cryptographic erase capable or not.

NOTE: When you select the Patrol Read option in the **Advanced...** section, an error message may be displayed. The error message can be safely ignored.

Secure erase

NOTE: Secure erase feature is supported only on the SED drives.

1 Enter the **Dell PERC 10 Configuration Utility**. See [Navigating to Dell PERC 10 configuration utility](#).

2 Click **Main Menu > Physical Disk Management**.

The list of virtual disks is displayed.

- 3 Select a virtual disk.
- 4 From the **Operations** drop-down menu, select **Secure Erase**.
ⓘ | NOTE: If the drive installed is SED capable, then only the Secure Erase option is displayed.
- 5 Click **Go**.
A screen is displayed asking if you are sure you want to perform the operation.
- 6 Select the **Confirm** option.
- 7 Click **Yes**.
The secure erase operation is completed successfully.

Cryptographic erase

ⓘ | NOTE: Crypto erase feature is supported only on the ISE drives.

- 1 Enter the **Dell PERC 10 Configuration Utility**. See [Navigating to Dell PERC 10 configuration utility](#).
- 2 Click **Main Menu > Physical Disk Management**.
The list of virtual disks is displayed.
- 3 Select a virtual disk.
- 4 From the **Operations** drop-down menu, select **Cryptographic Erase**.
ⓘ | NOTE: If the drive installed is ISE capable, then only the Cryptographic Erase option is displayed.
- 5 Click **Go**.
A screen is displayed asking if you are sure you want to perform the operation.
- 6 Select the **Confirm** option.
- 7 Click **Yes**.
The cryptographic erase operation is completed successfully.

Physical disk erase

To use the Physical Disk Erase feature from the HLL Configuration Utility, perform the following steps:

- 1 Enter the **Dell PERC 10 Configuration Utility**. See [Navigating to Dell PERC 10 configuration utility](#).
- 2 Click **Main Menu > Physical Disk Management**.
The list of virtual disks is displayed.
- 3 Select a virtual disk.
- 4 From the **Operations** drop-down menu, select **Physical Disk Erase**.
ⓘ | NOTE: If the drive installed is neither SED or ISE capable, then only the Physical Disk Erase option is displayed.
- 5 Click **Go**.
A screen is displayed asking if you are sure you want to perform the operation.
- 6 Select the **Confirm** option.
- 7 Click **Yes**.
The physical disk erase operation is completed successfully.

Assigning global hot spare

To assign a global hot spare from the HII Configuration Utility, perform the following steps:

- 1 Enter the **Dell PERC 10 Configuration Utility**. See [Navigating to Dell PERC 10 configuration utility](#).
- 2 Click **Main Menu > Physical Disk Management**.
The list of physical disks is displayed.
- 3 Select the physical disk.
- 4 From the **Operations** drop-down menu, select **Assign Global Hot Spare**.
- 5 Click **Go**.
A screen is displayed asking if you are sure you want to perform the operation.
- 6 Select the **Confirm** option.
- 7 Click **Yes**.
The global hot spare disk is created successfully.

Assigning dedicated hot spare

To assign a dedicated hot spare from the HII Configuration Utility, perform the following steps:

- 1 Enter the **Dell PERC 10 Configuration Utility**. See [Navigating to Dell PERC 10 configuration utility](#).
- 2 Click **Main Menu > Physical Disk Management**.
The list of physical disks is displayed.
- 3 Select the physical disk.
- 4 From the **Operations** drop-down menu, select **Assign Dedicated Hot Spare**.
- 5 Click **Go**.
A screen is displayed asking if you are sure you want to perform the operation.
- 6 Select the **Confirm** option.
- 7 Click **Yes**.
The dedicated hot spare disk is created successfully.

Hardware components

Viewing battery properties

- 1 Enter the **Dell PERC 10 Configuration Utility**. See [Navigating to Dell PERC 10 configuration utility](#).
- 2 Click **Main Menu > Hardware Components > Battery Management**.
The battery and capacity information are displayed.
- 3 You can view the following properties of the battery:

Field	Description
Type	Indicates the type of battery available.
Status	Indicates the current status of the battery.
Temperature	Indicates the current temperature of the battery and also indicates whether the temperature is Normal or High .
Charge	Indicates the available charge of the battery in percentage.

- 4 Click **Advanced...**.
The additional advanced properties of the physical battery are displayed.

- 5 You can view the following advanced properties of the battery:

Field	Description
Status	Indicates whether the current status of the battery is Learning, Degraded, or Failed.
Voltage	Indicates whether the voltage status of the battery is normal or high.
Current	Indicates power consumption of the battery in milliamps (mA).
Full Capacity	Indicates the maximum charge capacity of the battery.
Remaining Capacity	Indicates the current charge capacity of the battery.
Expected Margin of Error	Indicates expected margin of error.
Completed Discharge Cycles	Indicates the completed discharge cycles.
Learn Mode	Indicates the condition of the battery. The learn cycle is a periodic operation that calculates the charge that is remaining in the battery to ensure there is sufficient energy.

Viewing physical disks associated with an enclosure

- 1 Enter the **Dell PERC 10 Configuration Utility**. See [Navigating to Dell PERC 10 configuration utility](#).
- 2 Click **Main Menu > Hardware Components > Enclosure Management**.
- 3 From the **Select Enclosure** field, choose the enclosure for which you need to view the physical disks.
All the physical disks that are associated with the virtual disk are displayed.
- 4 Click the **Attached Physical Disks** drop-down box.
All the physical disks that are associated with the selected enclosure are displayed.

Security key and RAID management

Security key implementation

The Dell PowerEdge RAID Controller (PERC) 10 series of cards support Self-Encrypting Disks (SED) for protection of data against loss or theft of SEDs. Protection is achieved by the use of encryption technology on the drives. There is one security key per controller. You can manage the security key under Local Key Management (LKM). The key can be escrowed in to a file using Dell OpenManage storage management application. The security key is used by the controller to lock and unlock access to encryption-capable physical disks. In order to take advantage of this feature, you must:

- 1 Have SEDs in your system.
- 2 Create a security key.

Security key management in the HII configuration utility

The Dell OpenManage storage management application and the **HII Configuration Utility** of the controller allow security keys to be created and managed as well as create secured virtual disks. The following section describes the menu options specific to security key management and provide detailed instructions to perform the configuration tasks. The contents in the following section apply to the **HII Configuration Utility**. For more information on the management applications, see [Management applications for PERC cards](#).

- The Virtual Disk Management screen, **VD Mgmt**, displays physical disk information and action menus. The following are security-related actions you can perform through the virtual disk management menu:
 - **Security Key Management**—Creates, changes, or deletes the security settings on a controller.
 - **Secure Disk Group**—Secures all virtual disks in disk group.
- The Physical Disk Management screen, **PD Mgmt**, displays physical disk information and action menus. The following are security-related actions you can perform through the physical disk management menu:
 - **Secure Erase**—Permanently erases all data on an encryption-capable physical disk and resets the security attributes.

For more information on the Physical Disk Management screen and the Virtual Disk Management screen, see [Physical disk management](#) and [Virtual disk management](#) respectively.

Local Key Management (LKM)

You can use LKM to generate the key ID and the passphrase required to secure the virtual disk. You can secure virtual disks, change security keys, and manage secured foreign configurations using this security mode.

NOTE: Under LKM, you are prompted for a passphrase when you create the key.

Creating security key

NOTE: There is no passphrase backup option when you create a security key; you need to remember your passphrase.

- 1 Enter the **Dell PERC 10 Configuration Utility**. See [Navigating to Dell PERC 10 configuration utility](#).
- 2 Click **Main Menu > Controller Management > Advanced Controller Management > Enable Security**.
- 3 Select the **Security Key Management** mode as **Local Key Management**.

- 4 Click **Ok**.
- 5 In the **Security Key Identifier** field, enter an identifier for your security key.
NOTE: The Security Key Identifier is a user supplied clear text label used to associate the correct security key with the controller.
- 6 If you want to use the passphrase generated by the controller, click **Suggest Passphrase**.
Assigns a passphrase suggested by the controller automatically.
- 7 In the **Passphrase** field, enter the passphrase.
NOTE: Passphrase is case-sensitive. You must enter minimum 8 or maximum 32 characters. Ensure that the characters contain at least one number, one lower case letter, one upper case letter, and one non-alphanumeric character.
- 8 In the **Confirm** field, re-enter the passphrase to confirm.
NOTE: If the Passphrase entered in the Passphrase and Confirm fields do not match, then you are prompted with an error message to enter the passphrase again.
- 9 Select the **I recorded the Security Settings for Future Reference** option.
- 10 Click **Enable Security**.
The Security Key is created successfully.

Changing security key

- 1 Enter the **Dell PERC 10 Configuration Utility**. See [Navigating to Dell PERC 10 configuration utility](#).
- 2 Click **Main Menu > Controller Management > Advanced Controller Management > Change Passphrase**.
- 3 Select the **Change Current Security Settings** option.
- 4 Click **Ok**.
- 5 Select the **Use the existing Security Key Identifier** option.
- 6 Enter the existing passphrase.
- 7 Select the **Use the existing passphrase** option.
- 8 Enter the new passphrase.
- 9 Re-enter the new passphrase to confirm.
- 10 Select the **I recorded the Security Settings for Future Reference** option.
- 11 Click **Change Passphrase**.
The new passphrase entered is saved successfully.

Disabling security key

- NOTE:** Disabling Security Key is active if there is a security key present on the controller.
- NOTE:** After the Disabling Security Key operation, all unconfigured, secured SEDs are secure-erased.

- 1 Enter the **Dell PERC 10 Configuration Utility**. See [Navigating to Dell PERC 10 configuration utility](#).
- 2 Click **Main Menu > Controller Management > Advanced Controller Management > Disable Security**.
You are prompted to confirm whether you want to continue.
- 3 Select the **Confirm** option.
- 4 Click **Yes**.
The security key is disabled successfully.

Creating secured virtual disk

To create a secured virtual disk, the controller must have a security key established first. See [Creating security key](#).

NOTE: Combining SAS and SATA hard drives within a virtual disk is not supported. Also, combining hard drives and solid state drives (SSDs) within a virtual disk is not supported.

After the security key is established, perform the following steps:

- 1 Enter the **Dell PERC 10 Configuration Utility**. See [Navigating to Dell PERC 10 configuration utility](#).
- 2 Click **Main Menu > Configuration Management > Create Virtual Disk**.
For more information, see [Creating the virtual disks](#).
- 3 Select the **Secure Virtual Disk** option.
- 4 Click **Create Virtual Disk**.
The secure virtual disk is created successfully.

Securing pre-existing virtual disk

- 1 Enter the **Dell PERC 10 Configuration Utility**. See [Navigating to Dell PERC 10 configuration utility](#).
- 2 Click **Main Menu > Virtual Disk Management**.
The list of virtual disks is displayed.
- 3 Select a virtual disk.
- 4 From the **Operations** drop-down menu, select **Secure Virtual Disk**.

NOTE: The virtual disks can be secured only when the virtual disks are in Optimal state.

Importing secure virtual disk

NOTE: The controller must have an existing security key before importing secured foreign virtual disk.

- 1 Enter the **Dell PERC 10 Configuration Utility**. See [Navigating to Dell PERC 10 configuration utility](#).
- 2 Click **Main Menu > Configuration Management > Manage Foreign Configurations > Preview Foreign Configurations**.
- 3 Click **Import Foreign Configuration**.
A screen is displayed asking if you are sure you want to perform the operation.
- 4 Enter **Passphrase** if importing virtual disk with a different passphrase.
- 5 Select the **Confirm** option.
- 6 Click **Yes**.
The foreign configuration is imported successfully.

Troubleshooting

To get help with your Dell PowerEdge RAID Controller (PERC) 10 series of cards, you can contact your Dell Technical Service representative or see [Dell.com/support](https://www.dell.com/support).

Topics:

- [Adapter at baseport not responding error message](#)
- [BIOS disabled error message](#)
- [Configured disks removed or not accessible error message](#)
- [Dirty cache data error message](#)
- [Discovery error message](#)
- [Drive Configuration Changes Error Message](#)
- [Windows operating system installation errors](#)
- [Firmware fault state error message](#)
- [Extra enclosure error message](#)
- [Foreign configuration found error message](#)
- [Foreign configuration not found in HII error message](#)
- [Degraded state of virtual disks](#)
- [Memory errors](#)
- [Preserved Cache State](#)
- [Security key errors](#)
- [General issues](#)
- [Physical disk issues](#)
- [SMART errors](#)
- [Replace member errors](#)
- [Linux operating system errors](#)
- [Disk carrier LED indicators](#)
- [HII error messages](#)

Adapter at baseport not responding error message

Error Message: Adapter at Baseport xxxx is not responding, where xxxx is the baseport of the controller.

Corrective Action: Contact Dell Technical Support.

BIOS disabled error message

Error Message: BIOS Disabled. No Logical Drives Handled by BIOS.

Probable Cause: This warning message is displayed after you disable the **ROM** option in the configuration utility. When the **ROM** option is disabled, the BIOS cannot boot to Int 13h and cannot provide the ability to boot from the virtual disk. Int 13h is an interrupt signal that supports numerous commands that are sent to the BIOS and then passed to the

physical disk. The commands include actions you can perform with a physical disk, such as reading, writing, and formatting.

Corrective Action: Enable the **ROM** option.

Configured disks removed or not accessible error message

Error Message: Some configured disks have been removed from your system or are no longer accessible. Check your cables and ensure all disks are present. Press any key or 'C' to continue.

Probable Cause: The message indicates that some configured disks were removed. If the disks were not removed, they are no longer accessible. The SAS cables for your system might be improperly connected.

Corrective Action: Check the cable connections and fix issues if any. Restart the system. If there are no cable problems, press any key or <C> to continue.

Dirty cache data error message

Error Message: The following virtual disks are missing: (x). If you proceed (or load the configuration utility), these virtual disks will be removed from your configuration. If you wish to use them at a later time, they will have to be imported. If you believe these virtual disks should be present, please power off your system and check your cables to ensure all disks are present. Press any key to continue, or 'C' to load the configuration utility. The cache contains dirty data, but some virtual disks are missing or will go offline, so the cached data cannot be written to disk. If this is an unexpected error, then please power off your system and check your cables to ensure all disks are present. If you continue, the data in cache will be permanently discarded. Press 'X' to acknowledge and permanently destroy the cached data.

Probable Cause: The controller preserves the dirty cache from a virtual disk if the disk becomes offline or is deleted because of missing physical disks. This message indicates that some configured disks were removed. If the disks were not removed, they are no longer accessible. The SAS cables for your system might be improperly connected.

Corrective Action: Check the cable connections and fix any problems. Restart the system. Use the HII configuration utility to import the virtual disk or discard the preserved cache. For the steps to discard the preserved cache, see [Clearing the cache memory](#).

Discovery error message

Error Message: A discovery error has occurred, please power cycle the system and all the enclosures attached to this system.

Probable Cause: This message indicates that discovery did not complete within 120 seconds. The SAS cables for your system might be improperly connected.

Corrective Action: Check the cable connections and fix any problems. Restart the system.

Drive Configuration Changes Error Message

Error Message: Entering the configuration utility in this state will result in drive configuration changes. Press 'Y' to continue loading the configuration utility

or please power off your system and check your cables to ensure all disks are present and reboot.

Probable Cause: The message is displayed after another HII warning indicating there are problems with previously configured disks and you have chosen to accept any changes and continue. The SAS cables for your system might be improperly connected.

Corrective Action: Check the cable connections and fix any problems before restarting the system. If there are no cable problems, press any key or <Y> to continue.

Windows operating system installation errors

Ensure to perform the following steps before installing Windows on 4 KB sector drives:

- 1 Read and understand about the updates to the version of Windows that you have installed. You can find this information in the Microsoft help.
- 2 Refer [Release Notes: Important Issues in Windows Server](#).

Firmware fault state error message

Error Message: Firmware is in Fault State.

Corrective Action: Contact Dell Technical Support.

Extra enclosure error message

Error Message: There are X enclosures connected to connector Y, but only maximum of 4 enclosures can be connected to a single SAS connector. Please remove the extra enclosures then restart your system.

Probable Cause: This message is displayed when the HII detects more than four enclosures connected to a single SAS connector.

Corrective Action: You must remove all additional enclosures and restart your system.

Foreign configuration found error message

Error Message: Foreign configuration(s) found on adapter. Press any key to continue, or 'C' to load the configuration utility or 'F' to import foreign configuration(s) and continue.

Probable Cause: When a controller firmware detects a physical disk with existing foreign metadata, it flags the physical disk as *foreign* and generates an alert indicating that a foreign disk was detected.

Corrective Action: Press <F> at this prompt to import the configuration (if all member disks of the virtual disk are present) without loading the **HII Configuration Utility**. Or press <C> to enter the **HII Configuration Utility** and either import or clear the foreign configuration.

Foreign configuration not found in HII error message

Error Message: The foreign configuration message is present during POST but no foreign configurations are present in the foreign view page in HII configuration utility. All virtual disks are in an optimal state.

Corrective Action: Ensure all your PDs are present and all VDs are in optimal state. Clear the foreign configuration using **HII configuration utility** or **Dell OpenManage Server Administrator Storage Management**.

 **CAUTION:** The physical disk goes to Ready state when you clear the foreign configuration.

If you insert a physical disk that was previously a member of a virtual disk in the system, and that disk's previous location has been taken by a replacement disk through a rebuild, you must manually remove the foreign configuration flag of the newly inserted disk.

Degraded state of virtual disks

A redundant virtual disk is in a degraded state when one or more physical disks have failed or are inaccessible. For example, if a RAID 1 virtual disk consists of two physical disks and one of them fails or become inaccessible, the virtual disk become degraded.

To recover a virtual disk from a degraded state, you must replace the failed physical disk and rebuild it. Once the rebuilding process is complete, the virtual disk state changes from degraded to optimal.

Memory errors

Memory errors can corrupt cached data, so the controllers are designed to detect and attempt to recover from the memory errors. Single-bit memory errors can be handled by the controller and do not disrupt normal operation. A notification is sent if the number of single-bit errors exceeds a threshold value.

Multi-bit errors are more serious as they result in corrupted data and data loss. The following are the actions that occur in the case of multi-bit errors:

- If a multi-bit error occurs while accessing data in the cache when the controller is started with dirty cache, the controller discards the cache contents. The controller generates a warning message to the system console to indicate that the cache was discarded and generates an event.
- If a multi-bit error occurs at run-time either in code/data or in the cache, the controller stops.
- The controller logs an event to the controller's internal event log and a message during POST is displayed indicating a multi-bit error has occurred.

 **NOTE:** In case of a multi-bit error, contact Dell Technical Support.

Preserved Cache State

The controller preserves the dirty cache from a virtual disk if the virtual disk becomes offline or is deleted because of missing physical disks. This preserved dirty cache is called pinned cache and is preserved until you import the virtual disk or discard the cache.

Use the **HII Configuration Utility** to select whether to import the virtual disk or discard the preserved cache.

Security key errors

Secured foreign import errors

A foreign configuration is a RAID configuration that already exists on a replacement physical disk that you install in a system. A secured foreign configuration is a RAID configuration that was created under a different security key.

There are two scenarios in which a secured foreign import fails:

- **The passphrase authentication fails**—A virtual disk secured with a security key different from the current controller security key cannot be imported without authentication of the original passphrase used to secure them. Supply the correct passphrase to import the secured foreign configuration. If you have lost or forgotten the passphrase, the secured foreign disks remain locked (inaccessible) until the appropriate passphrase is entered or if they are secure erased.
- **The secured virtual disk is in an offline state after supplying the correct passphrase**—You must check to determine why the virtual disk failed and correct the problem.

Failure to select or configure non Self-Encrypting Disks (non-SED)

A virtual disk can be either secured or unsecured depending on how it was configured when created. In order to create a secured virtual disk, the controller must have a security key present and must contain SEDs only. In order to select/configure non-SED, you must create an unsecured virtual disk. You can create an unsecured virtual disk even if there is a security key. Select the **Secure VD** option as **No** in the **Create New VD** menu. For steps on how to create an unsecured virtual disk, see [Creating the virtual disks](#).

Failure to delete security key

A security key is used to lock or unlock access to a security-enabled component. This key is not utilized in the actual encryption of data. If a security key is present, both secured and unsecured virtual disks may exist.

To delete the security key, you must have a previously established security key present on the controller and there cannot be any configured secured disks. If there are configured secured virtual disks, remove or delete them.

Failure to secure erase task on physical disks

Secure Erase is the process of securely erasing all data permanently on an encryption-capable physical disk and resetting the security attributes. It is used in a couple of scenarios such as deleting a foreign configuration in the event of a forgotten or lost passphrase or unlocking a disk that had been previously locked.

Secure Erase can be executed only on encryption-capable disks as long as the disks are not hot spares and are not configured (part of a virtual disk). Ensure that the conditions are met and see [Secure erase](#).

General issues

PERC card has yellow bang in device manager

Issue: The device is displayed in **Device Manager** but has a yellow bang (exclamation mark).

Corrective Action: Reinstall the driver. For more information on reinstalling drivers, see [Driver installation](#).

PERC card not seen in device manager

Issue: The device does not appear in the **Device Manager**.

Corrective Action: Turn off the system and reseal the controller.
For more information, see [Deploying the PERC card](#).

Physical disk issues

Physical disk in failed state

- Issue:** One of the physical disks in the disk array is in the failed state.
- Corrective Action:** Update the PERC cards to the latest firmware available on [Dell.com/support](https://www.dell.com/support) and replace the drive.

Unable to rebuild a fault tolerant virtual disk

- Issue:** Cannot rebuild a fault tolerant virtual disk. For more information, see the alert log for virtual disks.
- Corrective Action:** The replacement disk is too small or not compatible with the virtual disk. Replace the failed disk with a compatible good physical disk with equal or greater capacity.

Fatal error or data corruption reported

- Issue:** Fatal error(s) or data corruption(s) are reported when accessing virtual disks.
- Corrective Action:** Contact Dell Technical Support.

Physical disk displayed as blocked

- Issue:** One or more physical disks is displayed as **Blocked** and cannot be configured.
- Corrective Action:** Update the PERC cards to the latest firmware available on [Dell.com/support](https://www.dell.com/support). Replace the drive and ensure not to use the blocked drive.

Multiple disks become inaccessible

- Issue:** Rebuilding the physical disks after multiple disks become simultaneously inaccessible.
- Corrective Action:** Multiple physical disk errors in a single array typically indicate a failure in cabling or connection and could involve the loss of data. You can recover the virtual disk after multiple physical disks become simultaneously inaccessible. Perform the following steps to recover the virtual disk:

 **CAUTION: Follow the safety precautions to prevent electrostatic discharge.**

- 1 Turn off the system, check cable connections, and reseal physical disks.
- 2 Ensure that all the disks are present in the enclosure.
- 3 Turn on the system and enter the **HII Configuration Utility**.
- 4 Import the foreign configuration.
- 5 Press <F> at the prompt to import the configuration, or press <C> to enter the **HII Configuration Utility** and either import or clear the foreign configuration.

If the virtual disk is redundant and transitioned to **Degraded** state before going **Offline**, a rebuild operation starts automatically after the configuration is imported. If the virtual disk has gone directly to the **Offline** state due to a cable pull or power loss situation, the virtual disk is imported in its **Optimal** state without a rebuild occurring.

NOTE: You can use the HII Configuration Utility or Dell OpenManage storage management application to perform a manual rebuild of multiple physical disks.

Rebuilding a failed physical disk

Issue: Rebuilding a physical disk that is in a failed state.

Corrective Action: If you have configured hot spares, the PERC card automatically tries to use one of the hot spares to rebuild a physical disk that is in a failed state. Manual rebuild is necessary if no hot spares with enough capacity to rebuild the failed physical disks are available. You must insert a physical disk with enough storage in the subsystem before rebuilding the physical disk.

NOTE: You can use the HII Configuration Utility or Dell OpenManage storage management application to perform a manual rebuild of an individual physical disk.

Virtual disk fails during rebuild using a global hot spare

Issue: A virtual disk fails during rebuild while using a global hot spare.

Description: The global hot spare reverts to **Hotspare** state and the virtual disk is in **Failed** state.

Virtual disk fails during rebuild using a dedicated hot spare

Issue: A virtual disk fails during rebuild while using a dedicated hot spare.

Description: You must manually rebuild or add a new drive to system and start rebuilding.

Physical disk fails during reconstruction on redundant virtual disk

Issue: A physical disk fails during a reconstruction process on a redundant virtual disk that has a hot spare.

Description: The dedicated hot spare reverts to **Ready** state and the virtual disk goes to **Failed** state.

Virtual disk fails rebuild using a dedicated hot spare

Issue: A virtual disk fails during rebuild while using a dedicated hot spare.

Description: The dedicated hot spare is in **Ready** state and the virtual disk is in **Failed** state.

Physical disk takes a long time to rebuild

- Issue:** A physical disk is taking longer than expected to rebuild.
- Description:** A physical disk takes longer to rebuild when under high stress. There is only one rebuild I/O operation for every five host I/O operations.
- Corrective Action:** If possible, reduce stress on the physical disk.

SMART errors

SMART monitors the internal performance of all motors, heads, and physical disk electronics and detects predictable physical disk failures.

NOTE: For information about where to find reports of SMART errors that could indicate hardware failure, see the Dell OpenManage storage management documentation at Dell.com/support/manuals.

Smart error detected on a physical disk in a redundant virtual disk

- Issue:** A SMART error is detected on a physical disk in a redundant virtual disk.
- Corrective Action:** Perform the following steps:
- 1 Back up your data.
 - 2 Force the physical disk offline.
NOTE: If a hot spare is present, the rebuild starts with the hot spare after the disk is forced offline.
 - 3 Replace the disk with a new physical disk of equal or higher capacity.
 - 4 Perform the **Replace Member** operation.
NOTE: The Replace Member operation allows you to copy data from a source physical disk of a virtual disk to a target physical disk that is not a part of the virtual disk. For more information about the Replace Member feature, see the topic [Configuring hot spare](#).

Smart error detected on a physical disk in a non-redundant virtual disk

- Issue:** A SMART error is detected on a physical disk in a non-redundant virtual disk.
- Corrective Action:** Perform the following steps:
- 1 Back up your data.
 - 2 Use **Replace Member** or set up a global hot spare to replace the disk automatically.
NOTE: For more information about the Replace Member feature, see the topic [Configuring hot spare](#).
 - 3 Replace the affected physical disk with a new physical disk of equal or higher capacity.
 - 4 Restore from the backup.

Replace member errors

① | **NOTE:** For more information about the **Replace Member** features, see [Configuring hot spare](#).

Source disk fails during replace member operation

- Issue:** The source disk fails during the **Replace Member** operation.
- Corrective Action:** If the source data is available from other disks in the virtual disk, the rebuild begins automatically on the target disk, using the data from the other disks.

Target disk fails

- Issue:** The target disk fails.
- Corrective Action:** If the target disk fails, the **Replace Member** operation aborts.

General disk fails

- Issue:** A general disk fails.
- Corrective Action:** If the target disk fails and the **Replace Member** operation aborts but the source data is still available, then the **Replace Member** operation continues as **Replace Member**.

Linux operating system errors

Virtual disk policy is assumed as write-through error message

- Error:** `<Date:Time> <HostName> kernel: sdb: asking for cache data failed<Date:Time>
<HostName> kernel: sdb: assuming drive cache: write through`
- Corrective Action:** The error message is displayed when the Linux Small Computer System Interface (SCSI) mid-layer asks for physical disk cache settings. The controller firmware manages the virtual disk cache settings on a per controller and a per virtual disk basis, so the firmware does not respond to this command. The Linux SCSI mid-layer assumes that the virtual disk's cache policy is **Write-Through**. SDB is the device node for a virtual disk. This value changes for each virtual disk.
- For more information about **Write-Through** cache, see [Virtual Disk Write Cache Policies](#).
- Except for this message, there is no effect of this behavior on normal operation. The cache policy of the virtual disk and the I/O throughput are not affected by this message. The cache policy settings for the PERC SAS RAID system remain unchanged.

Unable to register SCSI device error message

Error: smartd[smartd[2338] Device: /dev/sda, Bad IEC (SMART) mode page, err=-5, skip device smartd[2338] Unable to register SCSI device /dev/sda at line 1 of file /etc/smartd.conf.

Corrective Action: This is a known issue. An unsupported command is entered through the user application. User applications attempt to direct Command Descriptor Blocks to RAID volumes. The error message does not affect the feature functionality. The **Mode Sense/Select** command is supported by firmware on the controller. However, the Linux kernel **daemon** issues the command to the virtual disk instead of to the driver **IOCTL** node. This action is not supported.

Disk carrier LED indicators

Each hard drive carrier has an activity indicator and a status indicator. The indicators provide information about the current status of the hard drive. The activity LED indicates whether hard drive is currently in use or not. The status LED indicates the power condition of the hard drive.

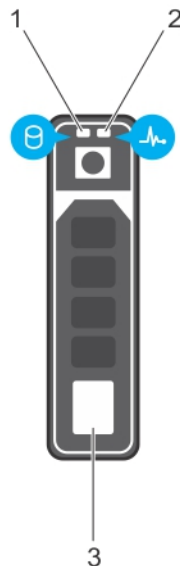

Figure 10. Hard drive indicators

- 1 activity LED
- 2 status LED
- 3 hard drive

NOTE: If the hard drive is in the Advanced Host Controller Interface (AHCI) mode, the status indicator (on the right side) does not turn on.

Table 10. Hard drive indicator codes

Drive status indicator pattern	Condition
Flashes green twice per second	Identifying drive or preparing for removal.
Off	Drive ready for insertion or removal.
Flashes green, amber, and then turns off	Predicted drive failure.

Drive status indicator pattern	Condition
Flashes amber four times per second	Drive failed.
Flashes green slowly	Drive rebuilding.
Steady green	Drive online.
Flashes green for three seconds, amber for three seconds, and then turns off after six seconds	Rebuild stopped.

HII error messages

Unhealthy Status of the Drivers

Error: One or more boot driver(s) have reported issues. Check the Driver Health Menu in Boot Manager for details.

Probable Cause: This message might indicate that the cables are not connected, the disks might be missing, or the UEFI driver might require configuration changes.

- Corrective Action:**
- 1 Check if the cables are connected properly, or replace missing hard drives, if any and then restart the system.
 - 2 Press any key to load the driver health manager to display the configurations. The Driver Health Manager displays the driver(s), which requires configuration.
 - 3 Alternately, if the UEFI driver requires configuration, press any key to load the Configuration Utility.

Appendix: RAID description

RAID is a group of independent physical disks that provides high performance by increasing the number of disks used for saving and accessing data.

⚠ CAUTION: In the event of a physical disk failure, a RAID 0 virtual disk fails, resulting in data loss.

A RAID disk subsystem offers the following benefits:

- Improved I/O performance and data availability.
- Improved data throughput because several disks are accessed simultaneously. The physical disk group appears either as a single storage unit or multiple logical units to the host system.
- Improved data storage availability and fault tolerance. Data loss caused by a physical disk failure can be recovered by rebuilding missing data from the remaining physical disks containing data or parity.

Topics:

- [Summary of RAID levels](#)
- [RAID terminology](#)

Summary of RAID levels

Following is the RAID levels supported by PERC 10 series of cards:

- RAID 0 uses disk striping to provide high data throughput, especially for large files in an environment that requires no data redundancy.
- RAID 1 uses disk mirroring so that data written to one physical disk is simultaneously written to another physical disk. RAID 1 is good for small databases or other applications that require small capacity and complete data redundancy.
- RAID 5 uses disk striping and parity data across all physical disks (distributed parity) to provide high data throughput and data redundancy, especially for small random access.
- RAID 6 is an extension of RAID 5 and uses an additional parity block. RAID 6 uses block-level striping with two parity blocks distributed across all member disks. RAID 6 provides protection against double disk failures, and failures while a single disk is rebuilding. If you are using only one array, deploying RAID 6 is more effective than deploying a hot spare disk.
- RAID 10 is a combination of RAID 0 and RAID 1, uses disk striping across mirrored disks. It provides high data throughput and complete data redundancy.
- RAID 50 is a combination of RAID 0 and RAID 5 where a RAID 0 array is striped across RAID 5 elements. RAID 50 requires at least six disks.
- RAID 60 is a combination of RAID 0 and RAID 6 where a RAID 0 array is striped across RAID 6 elements. RAID 60 requires at least eight disks.

The following table lists the minimum and maximum disks supported on each RAID levels.

Table 11. Minimum and maximum disks supported on each RAID levels

RAID Level	Minimum disk	Maximum disk
0	1	32
1	2	2
5	3	32

RAID Level	Minimum disk	Maximum disk
6	4	32
10	4	64
50	6	64
60	8	64

RAID terminology

Disk striping

Disk striping allows you to write data across multiple physical disks instead of just one physical disk. Disk striping involves partitioning each physical disk storage space in stripes of the following sizes: 64 KB, 128 KB, 256 KB, 512 KB, and 1 MB. The stripes are interleaved in a repeated sequential manner. The part of the stripe on a single physical disk is called a stripe element.

For example, in a four-disk system using only disk striping (used in RAID 0), segment 1 is written to disk 1, segment 2 is written to disk 2, and so on. Disk striping enhances performance because multiple physical disks are accessed simultaneously, but disk striping does not provide data redundancy.

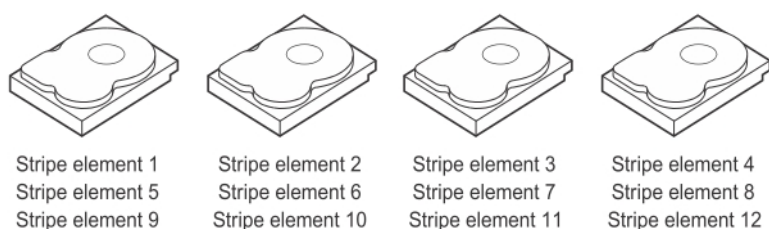

Figure 11. Example of disk striping (RAID 0)

Disk mirroring

With mirroring (used in RAID 1), data written to one disk is simultaneously written to another disk. If one disk fails, the contents of the other disk can be used to run the system and rebuild the failed physical disk. The primary advantage of disk mirroring is that it provides complete data redundancy. Both disks contain the same data at all times. Either of the physical disks can act as the operational physical disk.

Disk mirroring provides complete redundancy, but is an expensive option because each physical disk in the system must be duplicated.

NOTE: Mirrored physical disks improve read performance by read load balance.

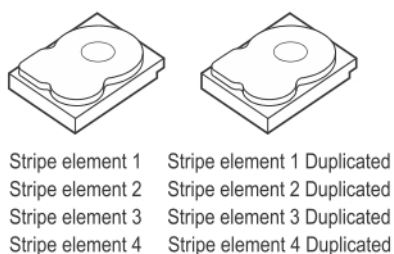

Figure 12. Example of Disk Mirroring (RAID 1)

Spanned RAID levels

Spanning is a term used to describe the way in which RAID levels 10, 50, and 60 are constructed from multiple sets of basic, or simple RAID levels. For example, a RAID 10 has multiple sets of RAID 1 arrays where each RAID 1 set is considered a span. Data is then striped (RAID 0) across the RAID 1 spans to create a RAID 10 virtual disk. Similarly, RAID 50 and RAID 60 combine multiple sets of RAID 5 or RAID 6 respectively with striping.

Parity data

Parity data is redundant data that is generated to provide fault tolerance within certain RAID levels. In the event of a disk failure, the parity data can be used by the controller to regenerate user data. Parity data is present for RAID 5, 6, 50, and 60.

The parity data is distributed across all the physical disks in the system. If a single physical disk fails, it can be rebuilt from the parity and the data on the remaining physical disks. RAID level 5 combines distributed parity with disk striping. Parity provides redundancy for one physical disk failure without duplicating the contents of the entire physical disks.

RAID 6 combines dual distributed parity with disk striping. This level of parity allows for two disk failures without duplicating the contents of entire physical disks.

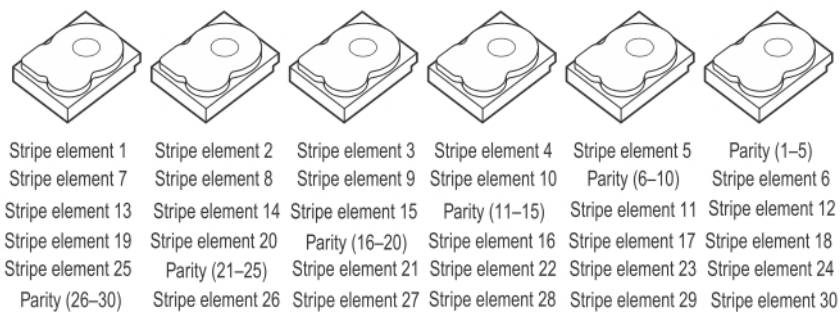

Figure 13. Example of Distributed Parity (RAID 5)

NOTE: Parity is distributed across multiple physical disks in the disk group.

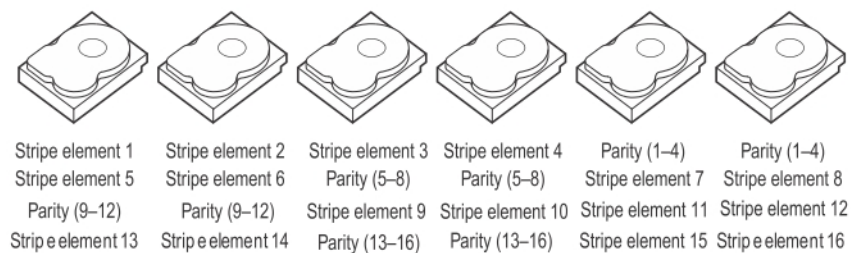

Figure 14. Example of Dual Distributed Parity (RAID 6)

NOTE: Parity is distributed across all disks in the array.

Getting help

You can get help with your Dell product by contacting Dell, or send feedback on product documentation.

Contacting Dell

Dell provides several online and telephone based support and service options. If you do not have an active internet connection, you can find contact information about your purchase invoice, packing slip, bill, or Dell product catalog. Availability varies by country and product, and some services may not be available in your area. To contact Dell for sales, technical assistance, or customer service issues:

- 1 Go to Dell.com/support.
- 2 Select your country from the drop-down menu on the lower right corner of the page.
- 3 For customized support:
 - a Enter your system Service Tag in the **Enter your Service Tag** field.
 - b Click **Submit**.The support page that lists the various support categories is displayed.
- 4 For general support:
 - a Select your product category.
 - b Select your product segment.
 - c Select your product.The support page that lists the various support categories is displayed.
- 5 For contact details of Dell Global Technical Support:
 - a Click [Global Technical Support](#).
 - b The **Contact Technical Support** page is displayed with details to call, chat, or e-mail the Dell Global Technical Support team.

Documentation feedback

Click the **Feedback** link in any of the Dell documentation pages, fill out the form, and click **Submit** to send your feedback.