

Dell EMC PowerEdge R740xd2

Technical Specifications

Notes, cautions, and warnings

 **NOTE:** A NOTE indicates important information that helps you make better use of your product.

 **CAUTION:** A CAUTION indicates either potential damage to hardware or loss of data and tells you how to avoid the problem.

 **WARNING:** A WARNING indicates a potential for property damage, personal injury, or death.

Chapter 1: Technical specifications.....	4
Chassis dimensions.....	5
System weight.....	5
Processor specifications.....	6
Supported operating systems.....	6
PSU specifications.....	6
Cooling fans specifications.....	7
System battery specifications.....	7
PCIe Expansion card riser specifications.....	7
Memory specifications.....	8
Storage controller specifications.....	8
Drives.....	8
Ports and connectors specifications.....	10
USB ports specifications.....	10
NIC ports specifications.....	10
Serial connector specifications.....	10
VGA ports specifications.....	10
IDSMD module.....	10
Video specifications.....	11
Environmental specifications.....	11
Standard operating temperature.....	12
Thermal restrictions.....	12
Particulate and gaseous contamination specifications	14

Technical specifications

The technical and environmental specifications of your system are outlined in this section.

Topics:

- Chassis dimensions
- System weight
- Processor specifications
- Supported operating systems
- PSU specifications
- Cooling fans specifications
- System battery specifications
- PCIe Expansion card riser specifications
- Memory specifications
- Storage controller specifications
- Drives
- Ports and connectors specifications
- Video specifications
- Environmental specifications

Chassis dimensions

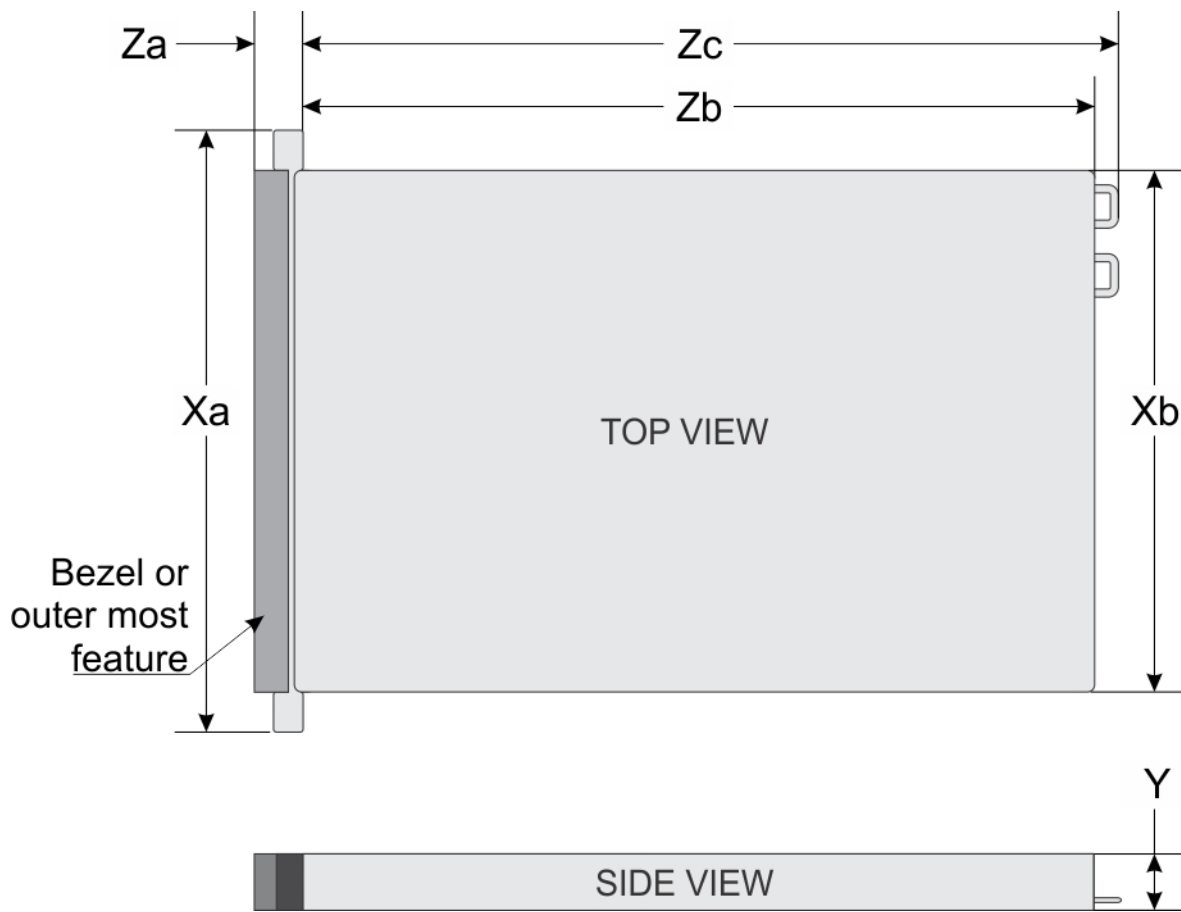

Figure 1. Chassis dimensions

Table 1. Dell EMC PowerEdge R740xd2 chassis dimensions

Xa	Xb	Y	Za	Zb*	Zc
482.0 mm (18.9 inches)	448.0 mm (17.63 inches)	86.8 mm (3.41 inches)	With bezel: 35.93 mm (1.41 inches) Without bezel: 22.0 mm (0.866 inches)	810.264 mm (31.9 inches)	844.826mm (33.260 inches)

NOTE: * - Zb refers to the nominal rear wall external surface, where the system board I/O connectors are located.

System weight

Table 2. Dell EMC PowerEdge R740xd2 system weight

System configuration	Maximum weight (with all drives/SSDs)
24+2 x 3.5-inch drives	40 kg (88.2 lb)

Processor specifications

Table 3. Dell EMC PowerEdge R740xd2 processor specifications

Supported processor	Number of supported processors
2 nd generation Intel Xeon Scalable Processor	Two

Supported operating systems

The Dell EMC PowerEdge R740xd2 supports the following operating systems:

- Canonical Ubuntu LTS
- Citrix XenServer
- Microsoft Windows Server
- Red Hat Enterprise Linux
- SUSE Linux Enterprise Server
- VMware ESXi

PSU specifications

The Dell EMC PowerEdge R740xd2 system supports up to two AC or DC power supply units (PSUs).

Table 4. PSU specifications

PSU	Class	Heat dissipation (maximum)	Frequency	Voltage	AC		DC	Current
					High line 100–240 V	Low line 100–120 V		
1100 W AC	Platinum	4100 BTU/hr	50/60 Hz	100–240 V AC, autoranging	1100 W	1050 W	NA	12 A–6.5 A
1100 W Mixed Mode HVDC (for China and Japan only)	Platinum	4416 BTU/hr	50/60 Hz	100–240 V AC, autoranging	1100 W	NA	NA	12 A–6.5 A
	Platinum	4416 BTU/hr	NA	200–380 V DC, autoranging	NA	NA	1100 W	6.4 A–3.2 A
750 W AC	Platinum	2891 BTU/hr	50/60 Hz	100–240 V AC, autoranging	750 W	NA	NA	10 A–5 A
750 W Mixed Mode	Platinum	2902 BTU/hr/	50/60 Hz	100–240 V AC, autoranging	750 W	NA	NA	10 A–5 A
	Platinum (For China only)	2902 BTU/hr/	NA	240 V DC, autoranging	NA	NA	750 W	5 A
750 W Mixed Mode HVDC (for China only)	Platinum	2902 BTU/hr/	50/60 Hz	100–240 V AC, autoranging	750 W	NA	NA	10 A–5 A
	Platinum	2902 BTU/hr	NA	240 V DC, autoranging	NA	NA	750 W	4.5 A

NOTE: Heat dissipation is calculated using the PSU wattage rating.

NOTE: This system is also designed to connect to the IT power systems with a phase-to-phase voltage not exceeding 240 V.

Cooling fans specifications

The Dell EMC PowerEdge R740xd2 system supports up to six high performance cooling fans.

NOTE: When selecting or upgrading the system configuration, to ensure optimum power utilization, verify the system power consumption with the Dell Energy Smart Solution Advisor available at Dell.com/ESSA.

Table 5. Dell EMC PowerEdge R740xd2 fan support matrix

Storage	PSU type	Processor count	Fan 1	Fan 2	Fan 3	Fan 4	Fan 5	Fan 6
24+2 x 3.5-inch or 24 x 3.5-inch.	Redundant PSUs only	1	Required	Required	Required	Required	Required	Required
		2	Required	Required	Required	Required	Required	Required

NOTE: Each fan is listed in the systems management software, referenced by the respective fan number. If there is a problem with a particular fan, you can easily identify and replace the proper fan by noting the fan numbers on the cooling fan assembly.

System battery specifications

The Dell EMC PowerEdge R740xd2 system supports CR 2032 3.0-V lithium coin cell system battery.

PCIe Expansion card riser specifications

The Dell EMC PowerEdge R740xd2 system supports up to three PCI express (PCIe) generation expansion cards that can be installed on the system board and expansion card risers.

Table 6. Expansion card slots supported on the system board

PCIe slots on the riser	Card support	Processor 1					Processor 2		PCH
		Riser 2 (LOM riser)	Right riser	Butterfly riser	On Planar	Internal riser	Left riser	On Planar	On Planar
PCIe slot-1	Unique to Dell	x8							
PCIe slot-2	Low profile-half length		x16						
PCIe slot-2	Full height-half length		x16	x8 or x16					
PCIe slot-3	Low profile-half length			x8			x16		
PCIe slot-4	Low profile-half length							x16	
PCIe slot-5	Low profile-half length				x4				

NOTE: PCIe slot 5 has open backend and bigger PCIe card

Table 6. Expansion card slots supported on the system board (continued)

PCIe slots on the riser	Card support	Processor 1					Processor 2		PCH
		Riser 2 (LOM riser)	Right riser	Butterfly riser	On Planar	Internal riser	Left riser	On Planar	On Planar
connection s can be inserted in this slot.									
PCIe slot-6	Low profile-half length								x4

NOTE: The expansion-card slots are not hot-swappable.

Memory specifications

The Dell EMC PowerEdge R740xd2 system supports 16 DDR4 registered DIMM (RDIMMs) slots. Supported memory bus frequencies are 1866 MT/s, 2133 MT/s, 2400 MT/s, and 2666 MT/s.

Table 7. Memory specifications

DIMM type	DIMM rank	DIMM capacity	Single processor		Dual processors	
			Minimum RAM	Maximum RAM	Minimum RAM	Maximum RAM
RDIMM	Single rank	8 GB	8 GB	80 GB	16 GB	128 GB
	Dual rank	16 GB	16 GB	160 GB	32 GB	256 GB
	Dual rank	32 GB	32 GB	320 GB	64 GB	512 GB

Storage controller specifications

The PowerEdge R740xd2 system supports the following controller cards.

Table 8. Dell EMC PowerEdge R740xd2 system controller cards

Internal controllers	External controllers
<ul style="list-style-type: none"> PERC H740P PERC H730P PERC H330 HBA330 S140 HBA350i,MMLP-B 	<ul style="list-style-type: none"> 12 Gbps SAS HBA PERC H840 PERC HBA355e

Drives

The Dell EMC PowerEdge R740xd2 system supports:

Table 9. Drive specification

Chassis options	Configurations
Twenty-four drive chassis	Up to twenty-four 3.5-inch (SATA or Nearline SAS drives) front accessible drives in slots 0 through 23 and

Table 9. Drive specification (continued)

Chassis options	Configurations
	Up to eight 2.5-inch (SAS, SATA SSDs) front accessible drives can be installed from slots 16 through 23.
Twenty-four front + two rear drive chassis	Up to twenty-four 3.5 inch (SATA or Nearline SAS drives) front accessible drives in slots 0 through 23 and up to two 3.5-inch SAS/SATA rear accessible drives.  NOTE: For single PERC configuration, it is slot 24 to slot 25. For dual PERC configuration including S140 software RAID, it is slot 0 to slot 1.

 **NOTE:** 2.5-inch drives in 3.5-inch carriers are supported for SAS, and SATA SSD drives.

Hard drives configurations

Table 10. Hard drives configurations

Chassis options	Configurations
Twenty-four 3.5-inch (12+12 with single PERC)	<ul style="list-style-type: none"> ● Drive Bay 1 physical slot number 0 through 11 <ul style="list-style-type: none"> ○ Logically numbered 0 through 11 ● Drive Bay 2 physical slot number 12 through 23 <ul style="list-style-type: none"> ○ Logically numbered 12 through 23
Twenty-four 3.5-inch front + two 3.5-inch rear (12 + 12 + 2 with single PERC)	<ul style="list-style-type: none"> ● Drive Bay 1 physical slot number 0 through 11 <ul style="list-style-type: none"> ○ Logically numbered 0 through 11 ● Drive Bay 2 physical slot number 12 through 23 <ul style="list-style-type: none"> ○ Logically numbered 12 through 23 ● Drive Bay 0 slot numbers 24 and 25 <ul style="list-style-type: none"> ○ Two drives in the rear chassis with logically numbered 24 and 25.
Twenty-four 3.5-inch front + two 3.5-inch rear (12 + 12 + 2 rear chipset SATA)	<ul style="list-style-type: none"> ● Drive Bay 1 physical slot number 0 through 11 <ul style="list-style-type: none"> ○ Logically numbered 0 through 11 ● Drive Bay 2 physical slot number 12 through 23 <ul style="list-style-type: none"> ○ Logically numbered 12 through 23 ● Drive Bay 0 slot numbers 24 and 25 <ul style="list-style-type: none"> ○ With this configuration, two drives in the rear chassis will be logically numbered 0 and 1.
Twenty-four 3.5-inch front + two 3.5-inch rear (Dual PERC: Bay 1 and 2 on first PERC, Bay 0 on second PERC)	<ul style="list-style-type: none"> ● Drive Bay 1 physical slot number 0 through 11 <ul style="list-style-type: none"> ○ Logically numbered 0 through 11 ● Drive Bay 2 physical slot number 12 through 23 <ul style="list-style-type: none"> ○ Logically numbered 12 through 23 ● Drive Bay 0 slot numbers 24 and 25 <ul style="list-style-type: none"> ○ With this configuration, two drives in the rear chassis will be logically numbered 0 and 1

Ports and connectors specifications

USB ports specifications

Table 11. Dell EMC PowerEdge R740xd2 system USB specifications

Front		Rear		Internal	
USB port type	No. of ports	USB port type	No. of ports	USB port type	No. of ports
USB 2.0-compliant port	One	USB 3.0-compliant ports	Two	Internal USB 3.0-compliant port	One
Micro USB 2.0-compliant port for iDRAC Direct NOTE: The micro USB 2.0 compliant port can only be used as an iDRAC Direct or a management port.	One				

NIC ports specifications

The Dell EMC PowerEdge R740xd2 system supports up to two Network Interface Controller (NIC) ports on the back panel, which have two 1 Gbps configuration.

NOTE: You can install up to six PCIe add-on NIC cards

Serial connector specifications

The Dell EMC PowerEdge R740xd2 system supports one serial connector on the back panel, which is a 9-pin connector, Data Terminal Equipment (DTE), 16550-compliant.

VGA ports specifications

The Dell EMC PowerEdge R740xd2 system supports one 15-pin VGA ports, on the rear of the system.

IDSDM module

The Dell EMC PowerEdge R740xd2 system supports optional Internal Dual SD module (IDSDM) module.

The module supports three microSD cards; two cards for IDSDM and one card for vFlash. In 14th generation of PowerEdge servers, the IDSDM or vFlash module is combined into a single card module, and is available in the following configurations:

- vFlash or
- vFlash and IDSDM

Table 12. Supported microSD card storage capacity

IDSDM card	vFlash card
<ul style="list-style-type: none"> • 16 GB • 32 GB • 64 GB 	<ul style="list-style-type: none"> • 16 GB

NOTE: There are two dip switches on the IDSDM or vFlash module for write-protection.

NOTE: One IDSDM card slot is dedicated for redundancy.

NOTE: Use Dell EMC branded microSD cards that are associated with the IDSDM or vFlash configured systems.

Video specifications

The Dell EMC PowerEdge R740xd2 system supports integrated Matrox G200eW3 graphics controller with 16 MB of video frame buffer.

Table 13. Supported video resolution options

Resolution	Refresh rate (Hz)	Color depth (bits)
1024 x 768	60	8, 16, 32
1280 x 800	60	8, 16, 32
1280 x 1024	60	8, 16, 32
1360 x 768	60	8, 16, 32
1440 x 900	60	8, 16, 32
1600 x 900	60	8, 16, 32
1600 x 1200	60	8, 16, 32
1680 x 1050	60	8, 16, 32
1920 x 1080	60	8, 16, 32
1920 x 1200	60	8, 16, 32

NOTE: 1920 x 1080 and 1920 x 1200 resolutions are only supported in reduced blanking mode.

Environmental specifications

NOTE: <https://www.dell.com/idracmanuals>

Table 14. Temperature specifications

Temperature	Specifications
Storage	-40–65°C (-40–149°F)
Continuous operation (for altitude less than 950 m or 3117 ft)	10–30°C (50–86°F) with no direct sunlight on the equipment
Fresh air	For information about fresh air, see the Expanded operating temperature section.
Maximum temperature gradient (operating and storage)	20°C/h (36°F/h)

Table 15. Relative humidity specifications

Relative humidity	Specifications
Storage	5% to 95% RH with 33°C (91°F) maximum dew point. Atmosphere must be noncondensing at all times.
Operating	10% to 80% RH with 29°C (84.2°F) maximum dew point.

Table 16. Maximum vibration specifications

Maximum vibration	Specifications
Operating	0.26 G _{rms} at 5 Hz to 350 Hz (all operation orientations)
Storage	1.88 G _{rms} at 10 Hz to 500 Hz for 15 minutes (all six sides tested)

Table 17. Maximum shock pulse specifications

Maximum shock pulse	Specifications
Operating	Six consecutively executed shock pulses in the positive and negative x, y, and z axis of 6 G for up to 11 ms.
Storage	Six consecutively executed shock pulses in the positive and negative x, y, and z axis (one pulse on each side of the system) of 71 G for up to 2 ms.

Table 18. Maximum altitude specifications

Maximum altitude	Specifications
Operating	3048 m (10,000 ft)
Storage	12,000 m (39,370 ft)

Table 19. Operating temperature derating specifications

Operating temperature derating	Specifications
Up to 30°C (86°F)	Maximum temperature is reduced by 1°C/300 m (1°F/547 ft), above 950 m (3,117 ft).
30–40°C (86–104°F)	Maximum temperature is reduced by 1°C/175 m (1°F/319 ft), above 950 m (3,117 ft).
40–45°C (104–113°F)	Maximum temperature is reduced by 1°C/125 m (1°F/228 ft), above 950 m (3,117 ft).

Standard operating temperature

Table 20. Standard operating temperature specifications

Standard operating temperature	Specifications
Continuous operation (for altitude less than 950 m or 3117 ft)	10°C to 30°C (50°F to 86°F) with no direct sunlight on the equipment.

Thermal restrictions

- System must operate at temperature below 30°C.
- All fans installed in the system must be from the same manufacturer.
- Fresh air condition is not supported.
- 140W processors are not supported in rear drive configuration.
- Non Dell qualified or certified processors are not supported.
- LRDIMM is not supported.
- 10 GbE / 25 GbE OCPs require PCIe shroud with rear drive configuration if there is no PCIe card installed.
- Butterfly without riser configuration cannot support 10GbE / 25GbE OCP because PCIe shroud cannot be installed.
- Drive bays should not be in service position for more than 5 minutes because of thermal concerns. When the drive bay is open for more than five minutes, the cooling fans spin at a higher speed to provide extra cooling to the system. Thus system health status changes from the normal to critical state, and system event The BP1 drive bay is kept open for an extended period of time is logged.
- GPGPU card is not supported.
- Non Dell certified peripheral cards are not supported.
- Expansion card and riser installation must follow specific Expansion card installation guidelines.
- Mellanox CX-5 dual port 100G - QSPF PCIe adapter cable is restricted to Dell NW QSPF28 Direct attach cables and Finisar 100G 85C optic cables. Non Dell certified cables are not supported.

Table 21. Thermal limitation standard

Configuration		Maximum no.of processors supported		DIMM blanks	Heat Sink	Type of Air shroud	Fan
		Quantity	Model				
Butterfly Configuration	No riser	1 or 2 processors	<=140 W	Required	Processor 1 : Standard heat sink Processor 2: 1.5 U HPR heatsink	2U Air shroud	6 x High Performance fans
	With Butterfly Riser						
Rear Module Configuration	Right Riser for 1x FH adapter card	1 or 2 processors	<=125 W		Processor 1 : Standard heat sink Processor 2: 1 U HPR heatsink	2U Air shroud for Rear 3.5" X 2 HDD	
	Right Riser + Left Riser for 2x LP adapter cards						

Table 22. Expansion cards thermal limitation

Thermal Cooling Tier level	Bus width	Full height Cards	Application Restriction (Configuration Type / PCIe slot)	Half height Cards	Application Restriction (Configuration Type / PCIe slot)
5	x8	-	Rear HDD Module Configuration / Slot# 2	QLOGIC 10G Dual port BT, QLOGIC 25G Dual port SFP	<ol style="list-style-type: none"> 1. Butterfly Riser Configuration / Slot# 3, 4, 5 2. Rear HDD Module Configuration / Slot# 2, 3 3. No Riser, No Rear HDD Module / Slot# 5
6		Mellanox 40G Dual Port CXP, QSFP, Solarflare 10G Dual Port SF852P, Solarflare 10G Dual Port SF852X		Mellanox 40G Dual Port CXP QSF, Solarflare 10G Dual Port SF852X, Solarflare 10G Dual Port SF852P	<ol style="list-style-type: none"> 1. Butterfly Riser Configuration / Slot# 3, 4, 5 2. Rear HDD Module Configuration / Slot# 2, 3
		Mellanox 40G Dual Port CXP, QSFP			<ol style="list-style-type: none"> 1. Butterfly Riser Configuration Slot# 3, 4 2. Rear HDD Module Configuration / Slot# 2,3
10		QLOGIC 10G Quad port QLGX		QLOGIC 10G Quad port QLGX	<ol style="list-style-type: none"> 1. Butterfly Riser Configuration / Slot# 3, 4 2. Rear HDD Module Configuration / Slot# 2, 3

Table 22. Expansion cards thermal limitation (continued)

Thermal Cooling Tier level	Bus width	Full height Cards	Application Restriction (Configuration Type / PCIe slot)	Half height Cards	Application Restriction (Configuration Type / PCIe slot)
8	x4	-	-	Intel NVME P4800X	Butterfly Riser Configuration / Slot# 3

Particulate and gaseous contamination specifications

The following table defines the limitations that help avoid any equipment damage or failure from particulates and gaseous contamination. If the levels of particulates or gaseous pollution exceed the specified limitations and result in equipment damage or failure, you may need to rectify the environmental conditions. Re-mediation of environmental conditions is the responsibility of the customer.

Table 23. Particulate contamination specifications

Particulate contamination	Specifications
Air filtration	Data center air filtration as defined by ISO Class 8 per ISO 14644-1 with a 95% upper confidence limit. <i>i</i> NOTE: This condition applies to data center environments only. Air filtration requirements do not apply to IT equipment designed to be used outside a data center, in environments such as an office or factory floor. <i>i</i> NOTE: Air entering the data center must have MERV11 or MERV13 filtration.
Conductive dust	Air must be free of conductive dust, zinc whiskers, or other conductive particles. <i>i</i> NOTE: This condition applies to data center and non-data center environments.
Corrosive dust	<ul style="list-style-type: none"> Air must be free of corrosive dust. Residual dust present in the air must have a deliquescent point less than 60% relative humidity. <i>i</i> NOTE: This condition applies to data center and non-data center environments.

Table 24. Gaseous contamination specifications

Gaseous contamination	Specifications
Copper coupon corrosion rate	<300 Å/month per Class G1 as defined by ANSI/ISA71.04-1985.
Silver coupon corrosion rate	<200 Å/month as defined by AHSRAE TC9.9.

i **NOTE:** Maximum corrosive contaminant levels measured at ≤50% relative humidity.