

Dell PowerEdge M630 Systems (VRTX Enclosure)

Owner's Manual

Notes, cautions, and warnings

 **NOTE:** A NOTE indicates important information that helps you make better use of your computer.

 **CAUTION:** A CAUTION indicates either potential damage to hardware or loss of data and tells you how to avoid the problem.

 **WARNING:** A WARNING indicates a potential for property damage, personal injury, or death.

© 2016 Dell Inc. All rights reserved. This product is protected by U.S. and international copyright and intellectual property laws. Dell and the Dell logo are trademarks of Dell Inc. in the United States and/or other jurisdictions. All other marks and names mentioned herein may be trademarks of their respective companies.

Contents

1 Dell PowerEdge M630p overview	7
Supported configurations for the PowerEdge M630p system.....	7
Front panel.....	8
2.5-inch hard drive or SSD system.....	9
1.8-inch SSD system.....	10
Diagnostic Indicators.....	11
iDRAC Direct LED indicator codes.....	11
Using USB diskette or USB DVD or CD drives.....	12
Hard drive or SSD indicator patterns.....	12
Locating Service Tag of your system.....	13
2 Documentation resources.....	14
3 Technical specifications.....	16
Chassis dimensions.....	16
Chassis weight.....	16
Processor specifications.....	16
System battery specifications	17
Memory specifications	17
RAID controllers.....	17
PCIe mezzanine card slots.....	17
Driver specification.....	17
Hard drives.....	17
SSDs.....	17
Optical drive.....	18
Flash drive.....	18
Ports and connectors specifications	18
USB ports.....	18
Internal Dual SD Module	18
Video specifications	18
Environmental specifications	18
Particulate and gaseous contamination specifications	20
Expanded operating temperature	21
Expanded operating temperature restrictions.....	21
4 Initial system setup and configuration.....	22
Setting up your system.....	22
iDRAC configuration.....	22
Options to set up iDRAC IP address.....	22
Options to install the operating system.....	23
Methods to download firmware and drivers.....	23

5 Pre-operating system management applications.....	25
Options to manage the pre-operating system applications.....	25
System Setup.....	25
Viewing System Setup.....	25
System Setup details.....	26
System BIOS.....	26
iDRAC Settings utility.....	46
Device Settings.....	47
Dell Lifecycle Controller.....	47
Embedded system management.....	47
Boot Manager.....	47
Viewing Boot Manager.....	47
Boot Manager main menu.....	48
PXE boot.....	48
6 Installing and removing server module components.....	49
Safety instructions.....	49
Before working inside your system.....	49
After working inside your system.....	50
Recommended tools.....	50
Installing and removing a server module.....	50
Removing a server module.....	50
Installing a server module.....	52
System cover.....	54
Removing the system cover.....	54
Installing the system cover.....	55
Inside the server module.....	57
System memory.....	57
General memory module installation guidelines.....	59
Mode-specific guidelines.....	60
Sample memory configurations.....	61
Removing memory modules.....	62
Installing memory modules.....	63
Cooling shroud.....	65
Removing the cooling shroud.....	65
Installing the cooling shroud.....	66
Processor blank and DIMM blank.....	66
Removing a processor or DIMM blank.....	67
Installing a processor or DIMM blank.....	68
PCIe mezzanine cards.....	69
Removing the PCIe mezzanine card.....	69
Installing the PCIe mezzanine card.....	70
Internal dual SD module (optional).....	71
Replacing an SD card.....	71
Internal USB key.....	73

Removing the optional IDSDM card.....	75
Installing the optional IDSDM card.....	76
rSPI card (optional).....	77
Removing the optional rSPI card.....	77
Installing the optional rSPI card.....	78
SD vFlash card.....	79
Replacing the SD vFlash card.....	80
Network Daughter Card.....	81
Removing the Network Daughter Card.....	81
Installing the Network Daughter Card.....	83
Processors.....	84
Removing a heat sink.....	84
Removing a processor.....	85
Installing a processor.....	88
Installing a heat sink.....	89
Hard drives or SSDs.....	91
Hard drive or SSD bay numbering.....	91
Hard drive or SSD installation guidelines.....	92
Removing a hard drive or SSD.....	92
Installing a hard drive or SSD.....	93
Removing a hard drive or SSD blank.....	94
Installing a hard drive or SSD blank.....	96
Shutdown procedure for servicing a hard drive.....	97
Configuring the boot drive.....	97
Removing a 2.5-inch hard drive or SSD from a 2.5-inch hard drive or SSD carrier.....	97
Installing a 2.5-inch hard drive or SSD in a 2.5-inch hard drive or SSD carrier.....	98
Removing a 1.8-inch SSD from a 1.8-inch SSD carrier.....	99
Installing a 1.8-inch SSD in a 1.8-inch SSD carrier.....	100
Removing the hard drive or SSD cage.....	101
Installing the hard drive or SSD cage.....	102
Hard drive or SSD backplane.....	104
Removing the hard drive or SSD backplane.....	104
Installing the hard drive or SSD backplane.....	106
Storage controller card.....	108
Removing the PCIe extender or storage controller card.....	108
Installing the PCIe extender or storage controller card.....	110
System board.....	111
Removing the system board.....	111
Installing the system board.....	114
Trusted Platform Module.....	117
NVRAM backup battery.....	119
Replacing the NVRAM backup battery.....	119
7 Using system diagnostics.....	122
Dell Embedded System Diagnostics.....	122
Running the Embedded System Diagnostics.....	122

Running embedded system diagnostics from an external media.....	122
System diagnostics controls.....	123
8 Jumpers and connectors	124
System board jumper settings.....	124
System board connectors.....	125
Disabling a forgotten password.....	126
9 Troubleshooting your system.....	127
Safety first — for you and your system.....	127
Troubleshooting system memory.....	127
Troubleshooting hard drives.....	128
Troubleshooting Solid State Drives.....	129
Troubleshooting USB devices.....	129
Troubleshooting an Internal SD Card.....	130
Troubleshooting processors.....	130
Troubleshooting the system board.....	131
Troubleshooting the NVRAM backup battery.....	131
10 Getting help.....	133
Contacting Dell.....	133
Accessing system information by using QRL.....	133
Quick Resource Locator for M630p.....	134

Dell PowerEdge M630p overview

The Dell PowerEdge M630p is a half-height server module supported on the PowerEdge M1000e and PowerEdge VRTX enclosure and support up to:

- One or two Intel Xeon E5-2600 v3 or E5-2600 v4 processors
- 24 DIMMs
- Single processor: Up to two 2.5-inch hard drives
- Single processor: Up to four 1.8-inch SSDs
- Dual processor: Up to two 2.5-inch hard drives
- Dual processor: Up to four 1.8-inch SSDs

Topics:

- [Supported configurations for the PowerEdge M630p system](#)
- [Front panel](#)
- [Diagnostic Indicators](#)
- [Locating Service Tag of your system](#)

Supported configurations for the PowerEdge M630p system

The Dell PowerEdge M630p system supports the following configurations:

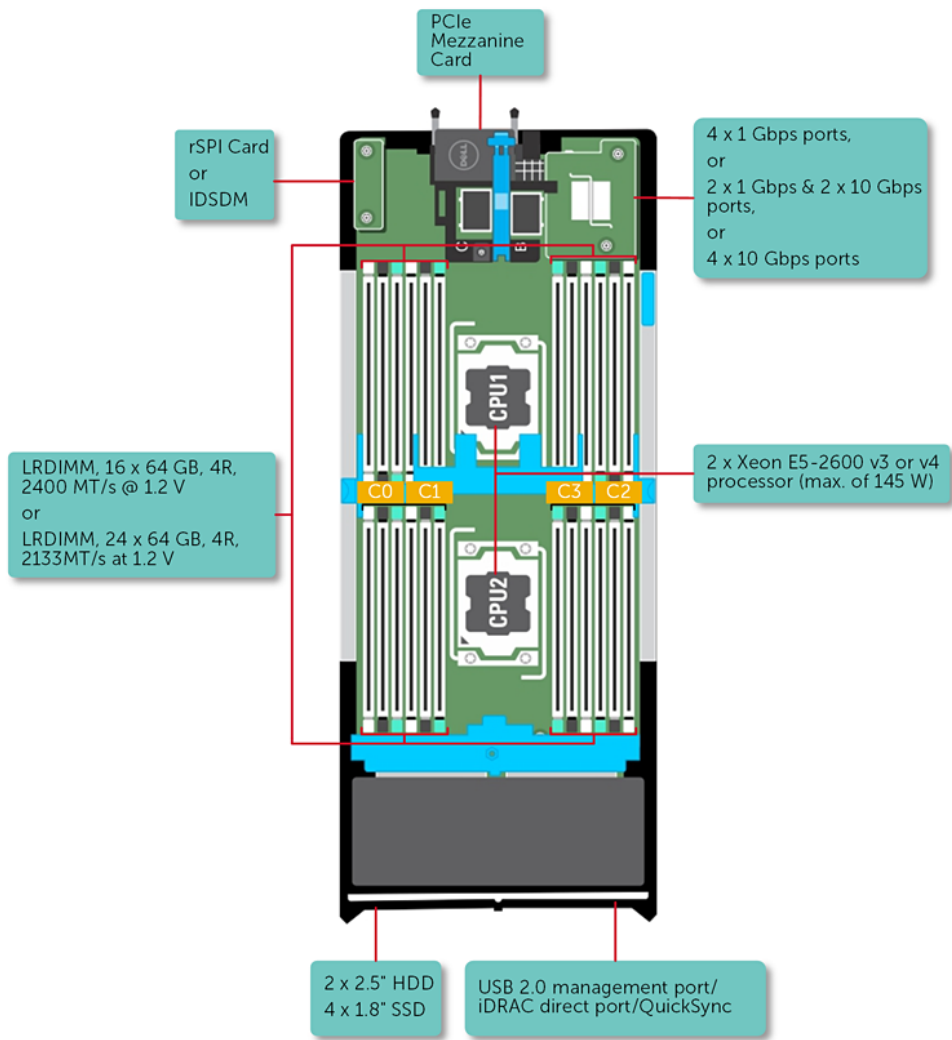

Figure 1. M630p configuration overview

Front panel

The features on the front panel include USB management port, iDRAC Direct LED indicator, sled handle and status indicator.

2.5-inch hard drive or SSD system

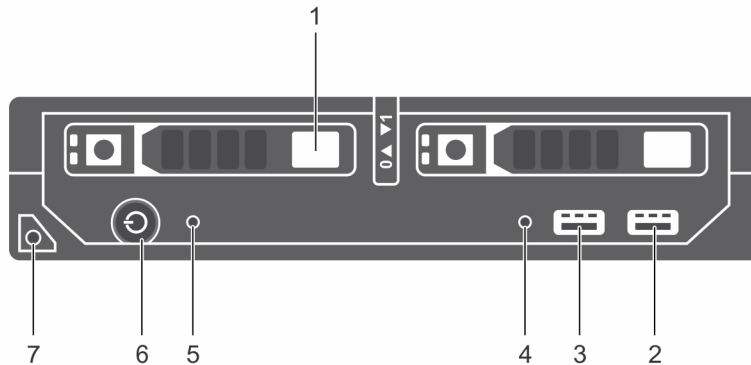





Figure 2. Front panel features — 2.5-inch hard drive or SSD system

- | | | | |
|---|-----------------------------------|---|--|
| 1 | Hard drives or SSDs | 2 | USB 3.0 port |
| 3 | USB 2.0 or iDRAC managed USB port | 4 | Management indicator |
| 5 | Status indicator | 6 | server module power-on indicator, power button |
| 7 | server module handle | | |

Table 1. Front panel features — 2.5-inch hard drive or SSDs system

Item	Indicator, Button, or Connector	Icon	Description
1	Hard drives or SSDs		2.5-inch hard drive system Two 2.5-inch hot-swap SAS or SATA or PCIe SSDs or SAS or SATA hard drives.
2	USB 3.0 port		A USB device to be connected to the system.
3	USB 2.0 or iDRAC managed USB port		The USB management port can function as a regular USB port or provide access to the iDRAC features. For more information, see the <i>Dell Integrated Dell Remote Access Controller User's Guide</i> at Dell.com/idracmanuals .
4	Management indicator		The indicator turns on when iDRAC controls the USB port for management functions.
5	Status indicator		Provides information about the status of the system.
6	server module power-on indicator, power button		The power indicator turns on when the server module power is on. The power button controls the power supply output to the system.
7	server module handle		Used to slide the server module out of the enclosure.

1.8-inch SSD system

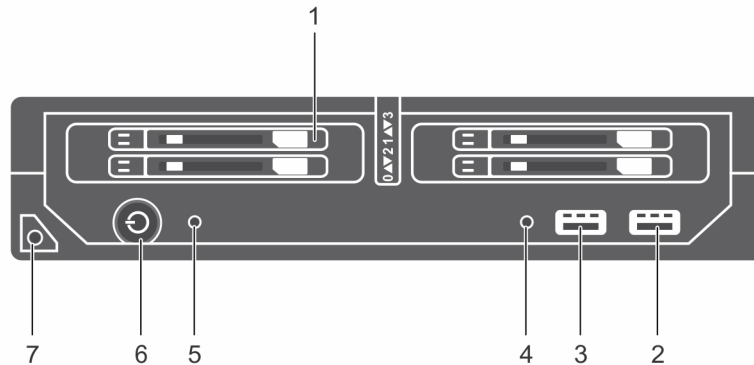





Figure 3. Front panel features — 1.8-inch SSD system

- | | | | |
|---|-----------------------------------|---|--|
| 1 | Hard drives or SSDs | 2 | USB 3.0 port |
| 3 | USB 2.0 or iDRAC managed USB port | 4 | Management indicator |
| 5 | Status indicator | 6 | server module power-on indicator, power button |
| 7 | server module handle | | |

Table 2. Front panel features — 1.8-inch SSD system

Item	Indicator, Button, or Connector	Icon	Description
1	Hard drives or SSDs		1.8-inch SSD system Four 1.8-inch hot-swap SATA SSDs.
2	USB 3.0 port		A USB device to be connected to the system.
3	USB 2.0 or iDRAC managed USB port		The USB management port can function as a regular USB port or provide access to the iDRAC features. For more information, see the <i>Dell Integrated Dell Remote Access Controller User's Guide</i> at Dell.com/idracmanuals .
4	Management indicator		The indicator turns on when iDRAC controls the USB port for management functions.
5	Status indicator		Provides information about the status of the system.
6	server module power-on indicator, power button		The power indicator turns on when the server module power is on. The power button controls the power supply output to the system.
7	server module handle		Used to slide the server module out of the enclosure.

Diagnostic Indicators

The diagnostic indicators on the system front panel display error status during system startup.

iDRAC Direct LED indicator codes

NOTE: The iDRAC Direct LED indicator does not turn on for the USB mode.

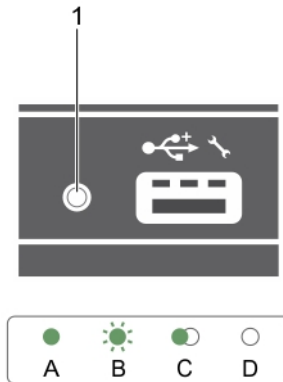

Figure 4. iDRAC Direct LED indicator

1 iDRAC Direct status indicator

Table 3. iDRAC Direct LED indicators

Convention	iDRAC Direct LED indicator pattern	Condition
A	Green	Turns green for a minimum of two seconds at the starting and end of a file transfer.
B	Flashing green	Indicates file transfer or any operation tasks.
C	Green and turns off	Indicates that the file transfer is complete.
D	Not lit	Indicates that the USB is ready to be removed or that a task is complete.

The following table describes iDRAC Direct activity when configuring iDRAC Direct by using your laptop and cable (Laptop Connect).

Table 4. iDRAC Direct LED indicator patterns

iDRAC Direct LED indicator pattern	Condition
Solid green for two seconds	Indicates that the laptop is connected.
Flashing green (on for two seconds and off for two seconds)	Indicates that the laptop connected is recognized.
Turns off	Indicates that the laptop is unplugged.

Using USB diskette or USB DVD or CD drives

The server module has USB ports on the front which allows you to connect a USB diskette drive, USB flash drive, USB DVD or CD drive, keyboard, or mouse. The USB drives can be used to configure the server module.

To designate the USB diskette drive as the boot drive:

- 1 connect the USB drive
- 2 restart the system
- 3 enter the System Setup
- 4 set the drive as first in the boot sequence

The USB device is displayed in the boot order setup screen only if it is attached to the system before you run the System Setup. You can also select the boot device by pressing F11 during system start-up and selecting a boot device for the current boot sequence.

Hard drive or SSD indicator patterns

The hard drive or SSD (Solid-State Drives) indicators display different patterns as drive events occur in the system.

NOTE: The server module must have a hard drive or SSD or a hard drive blank installed in each drive bay.

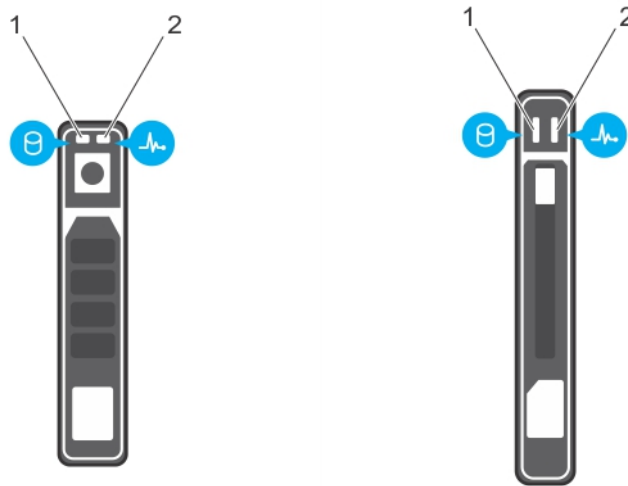

Figure 5. Hard drive or SSD indicators

- 1 drive activity indicator (green)
- 2 drive status indicator (green and amber)

NOTE: If the drive is in Advanced Host Controller Interface (AHCI) mode, the status LED (on the right side) does not function and remains off.

Drive-Status Indicator Pattern	Condition
Flashes green twice per second	Identifying drive or preparing for removal

Drive-Status Indicator Pattern	Condition
--------------------------------	-----------

Off	Drive ready for insertion or removal
-----	--------------------------------------

i **NOTE:** The drive status indicator remains off until all drives are initialized after system power is applied. Drives are not ready for insertion or removal during this time.

Flashes green, amber, and then turns off	Drive predicted failure
--	-------------------------

Flashes amber four times per second	Drive failed
-------------------------------------	--------------

Flashes green slowly	Drive rebuilding
----------------------	------------------

Steady green	Drive online
--------------	--------------

Flashes green for three seconds, amber for three seconds, and turns off after six seconds	Rebuild stopped
---	-----------------

Locating Service Tag of your system

Your system is identified by a unique Express Service Code and Service Tag number. The Express Service Code and Service Tag are found on the front of the system by pulling out the information tag. Alternatively, the information may be on a sticker on the chassis of the system. This information is used by Dell to route support calls to the appropriate personnel.

Documentation resources

This section provides information about the documentation resources for your system.

Table 5. Documentation resources for system

Task	Document	Location
Setting up your system	For information about installing the system into a rack, see the Rack documentation included with your rack solution.	Dell.com/poweredgemanuals
	For information about turning on the system and the technical specifications of your system, see the <i>Getting Started With Your System</i> that shipped with your system.	Dell.com/poweredgemanuals
	For information about <i>Getting Started With Your System</i> that shipped with your system or the Technical specifications section in this document.	Dell.com/poweredgemanuals
Configuring your system	For information about iDRAC features, configuring and logging in to iDRAC, and managing your system remotely, see the Integrated Dell Remote Access Controller User's Guide.	Dell.com/idracmanuals
	For information about installing the operating system, see the operating system documentation.	Dell.com/operatingsystemmanuals
	For information about understanding Remote Access Controller Admin (RACADM) subcommands and supported RACADM interfaces, see the RACADM Command Line Reference Guide for iDRAC.	Dell.com/idracmanuals
	For information about updating drivers and firmware, see the Download firmware and drivers section in this document.	Dell.com/support/drivers
Managing your system	For information about the features of the Dell OpenManage Systems Management, see the Dell OpenManage Systems Management Overview Guide.	Dell.com/openmanagemanuals
	For information about setting up, using, and troubleshooting OpenManage, see the Dell OpenManage Server Administrator User's Guide.	Dell.com/openmanagemanuals
	For information about installing, using, and troubleshooting Dell OpenManage Essentials, see the Dell OpenManage Essentials User's Guide.	Dell.com/openmanagemanuals

Task	Document	Location
	For information about installing and using Dell System E-Support Tool (DSET), see the Dell System E-Support Tool (DSET) User's Guide.	Dell.com/DSET
	For information about installing and using Active System Manager (ASM), see the Active System Manager User's Guide.	Dell.com/asmdocs
	For understanding the features of Dell Lifecycle Controller (LCC), see the Dell Lifecycle Controller User's Guide.	Dell.com/idracmanuals
	For information about partner programs enterprise systems management, see the OpenManage Connections Enterprise Systems Management documents.	Dell.com/omconnectionsenterprisesystemsmanagement
	For information about connections and client systems management, see the OpenManage Connections Client Systems Management documentation.	Dell.com/dellclientcommandsuitemanuals
	For information about viewing inventory, performing configuration and monitoring tasks, remotely turning on or off servers, and enabling alerts for events on servers and components using the Dell Chassis Management Controller (CMC), see the CMC User's Guide.	Dell.com/esmmanuals
Working with Dell PowerEdge RAID controllers	For information about understanding the features of the Dell PowerEdge RAID controllers (PERC) and deploying the PERC cards, see the Storage controller documentation.	Dell.com/storagecontrollermanuals
Understanding event and error messages	For information about checking the event and error messages generated by the system firmware and agents that monitor system components, see the Dell Event and Error Messages Reference Guide.	Dell.com/openmanagemanuals > OpenManage software

Technical specifications

The technical and environmental specifications of your system are outlined in this section.

Chassis dimensions

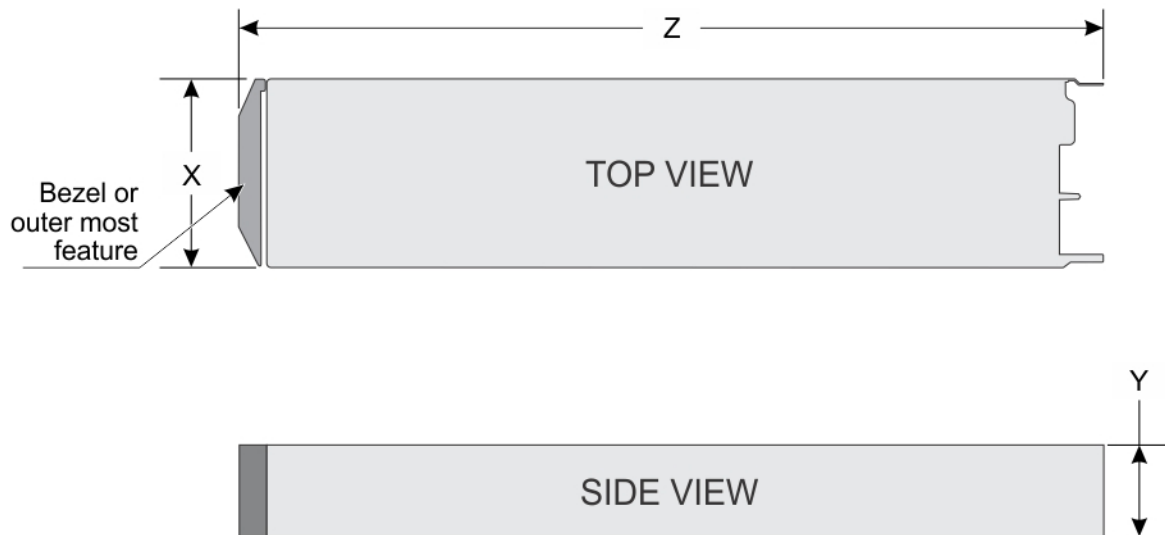

Figure 6. Chassis dimensions

Table 6. Chassis dimensions of the Dell PowerEdge M630p system

System	X	Y	Z
PowerEdge M630p	192.3 mm	50.3 mm	544.3 mm

Chassis weight

Table 7. Chassis weight

System	Maximum weight
PowerEdge M630p	6.8 kg (14.99 lb)

Processor specifications

The PowerEdge M630p system supports up one or two Intel Xeon E5-2600 v3 or E5-2600 v4 product family processors.

⚠ CAUTION: For processors of 105 W, 120 W, or 135 W, use heat sinks of 68 mm width.

⚠ CAUTION: For processors of 135 W (four cores, six cores, or eight cores) or 145 W, use heat sinks of 86 mm width.

📌 NOTE: Mixing processors of different wattages is not supported.

System battery specifications

The PowerEdge M630p system supports CR 2032 3.0-V lithium coin cell system battery.

Memory specifications

The PowerEdge M630p system supports DDR4 registered DIMMs (RDIMMs) and load-reduced DIMMs (LRDIMMs).

Table 8. Memory specifications

Memory module sockets	Memory capacity	Minimum RAM	Maximum RAM	Speed
PowerEdge M630p	64 GB quad rank (LRDIMMs)	4 GB with single processor	<ul style="list-style-type: none">Up to 768 GB with a single processorUp to 1536 GB with a dual processor	2400 MT/s, 2133 MT/s, or 1866 MT/s, DDR4 DIMMs
	32 GB quad rank (LRDIMMs)			2133 MT/s, or 1866 MT/s, DDR4 DIMMs
	4 GB, 8 GB, 16 GB or 32 GB single rank (RDIMMs)			2400 MT/s, 2133 MT/s, or 1866 MT/s, DDR4 DIMMs
	8 GB, 16 GB and 32 GB dual rank (RDIMMs)			2400 MT/s, 2133 MT/s, or 1866 MT/s, DDR4 DIMMs

RAID controllers

The PowerEdge M630p system supports PERC H330, PERC H730P, and PERC H730.

PCIe mezzanine card slots

The PowerEdge M630p system supports Two PCIe x8 Gen 2 slots that support PCIe mezzanine cards

Driver specification

Hard drives

The PowerEdge M630p system supports:

- Up to two 2.5-inch, hot-swappable SAS, SATA hard drives or SAS or SATA or PCIe SSDs

SSDs

The PowerEdge M630p system supports:

- Up to four 1.8-inch, hot-swappable SATA SSDs

Optical drive

The PowerEdge M630p system supports external optional USB DVD and one optional SATA DVD-ROM drive or DVD+/-RW drive.

Flash drive

The PowerEdge M630p system supports internal optional USB, internal optional SD card and optional vFlash card (with integrated iDRAC8 Enterprise).

Ports and connectors specifications

USB ports

The PowerEdge M630p system supports:

- One USB 2.0-compliant and one USB 3.0-compliant port on the front panel
- Internal USB 2.0-compliant port

The following table provides more information about the USB specifications:

Table 9. USB specifications

System	Front panel	Internal
PowerEdge M630p	One 4-pin, USB 2.0-compliant and one 4-pin, USB 3.0-compliant	<ul style="list-style-type: none">• Two internal SD cards dedicated for the hypervisor• One SD card dedicated for future vFlash support

Internal Dual SD Module

The PowerEdge M630p system supports two SD card slots and a USB interface dedicated for the embedded hypervisor. This card offers the following features:

- Dual card operation — maintains a mirrored configuration by using SD cards in both slots and provides redundancy.
- Single card operation — single card operation is supported, but without redundancy.

Video specifications

The PowerEdge M630p system supports Matrox G200 VGA controller integrated with iDRAC and 2 GB shared with iDRAC application memory.

Environmental specifications

NOTE: For additional information about environmental measurements for specific system configurations, see Dell.com/environmental_datasheets.

Table 10. Temperature specifications

Temperature	Specifications
Storage	-40°C to 65°C (-40°F to 149°F)
Continuous operation (for altitude less than 950 m or 3117 ft)	10°C to 35°C (50°F to 95°F) with no direct sunlight on the equipment.
Fresh air	For information about fresh air, see Expanded Operating Temperature section.
Maximum temperature gradient (operating and storage)	20°C/h (36°F/h)

Table 11. Relative humidity specifications

Relative humidity	Specifications
Storage	5% to 95% RH with 33°C (91°F) maximum dew point. Atmosphere must be noncondensing always.
Operating	10% to 80% Relative Humidity with 29°C (84.2°F) maximum dew point.

Table 12. Maximum vibration specifications

Maximum vibration	Specifications
Operating	0.26 Grms at 5 Hz to 350 Hz (all operation orientations).
Storage	1.88 Grms at 10 Hz to 500 Hz for 15 min (all six sides tested).

Table 13. Maximum shock specifications

Maximum shock	Specifications
Operating	Six consecutively run shock pulses in the positive and negative x, y, and z axes of 40 G for up to 2.3 ms.
Storage	Six consecutively run shock pulses in the positive and negative x, y, and z axes (one pulse on each side of the system) of 71 G for up to 2 ms.

Table 14. Maximum altitude specifications

Maximum altitude	Specifications
Operating	3048 m (10,000 ft).
Storage	12,000 m (39,370 ft).

Table 15. Operating temperature derating specifications

Temperature	Specifications
Up to 35 °C (95 °F)	Maximum temperature is reduced by 1°C/300 m (1°F/547 ft) above 950 m (3,117 ft).
35 °C to 40 °C (95 °F to 104 °F)	Maximum temperature is reduced by 1°C/175 m (1°F/319 ft) above 950 m (3,117 ft).
40 °C to 45 °C (104 °F to 113 °F)	Maximum temperature is reduced by 1°C/125 m (1°F/228 ft) above 950 m (3,117 ft).

Particulate and gaseous contamination specifications

The following table defines the limitations that help avoid any equipment damage or failure from particulates and gaseous contamination. If the levels of particulates or gaseous pollution exceed the specified limitations and result in equipment damage or failure, you may need to rectify the environmental conditions. Remediation of environmental conditions is the responsibility of the customer.

Table 16. Particulate contamination specifications

Particulate contamination	Specifications
Air filtration	<p>Data center air filtration as defined by ISO Class 8 per ISO 14644-1 with a 95% upper confidence limit.</p> <p>NOTE: This condition applies only to data center environments. Air filtration requirements do not apply to IT equipment designed to be used outside a data center, in environments such as an office or factory floor.</p> <p>NOTE: Air entering the data center must have MERV11 or MERV13 filtration.</p>
Conductive dust	<p>Air must be free of conductive dust, zinc whiskers, or other conductive particles.</p> <p>NOTE: This condition applies to data center and nondata center environments.</p>
Corrosive dust	<ul style="list-style-type: none"> Air must be free of corrosive dust. Residual dust present in the air must have a deliquescent point less than 60% relative humidity. <p>NOTE: This condition applies to data center and nondata center environments.</p>

Table 17. Gaseous contamination specifications

Gaseous contamination	Specifications
Copper coupon corrosion rate	<300 Å/month per Class G1 as defined by ANSI/ISA71.04-1985.
Silver coupon corrosion rate	<200 Å/month as defined by AHSRAE TC9.9.

NOTE: Maximum corrosive contaminant levels measured at ≤50% relative humidity.

Expanded operating temperature

Table 18. Expanded operating temperature specifications

Expanded operating temperature	Specifications
Continuous operation	<p>5°C to 40°C at 5% to 85% RH with 29°C dew point.</p> <p>NOTE: Outside the standard operating temperature (10°C to 35°C), the system can operate continuously in temperatures as low as 5°C and as high as 45°C.</p> <p>For temperatures between 35°C and 40°C, derate maximum allowable temperature by 1°C per 175 m above 950 m (1°F per 319 ft).</p>
< 1% of annual operating hours	<p>–5°C to 45°C at 5% to 90% RH with 29°C dew point.</p> <p>NOTE: Outside the standard operating temperature (10°C to 35°C), the system can operate down to –5°C or up to 45°C for a maximum of 1% of its annual operating hours.</p> <p>For temperatures between 40°C and 45°C, de-rate maximum allowable temperature by 1°C per 125 m above 950 m (1°F per 228 ft).</p>

NOTE: When operating in the expanded temperature range, system performance may be impacted.

NOTE: When operating in the expanded temperature range, ambient temperature warnings may be reported on the LCD panel and in the System Event Log.

Expanded operating temperature restrictions

- Do not perform a cold startup below 5°C.
- 135 W (4 core, 6 core, or 8 core) and 145 W processors are not supported.
- Non-Dell qualified peripheral cards and/or peripheral cards greater than 25 W are not supported.
- PCIeSSD is not supported.
- When populating the server module slots in the PowerEdge VRTX enclosure with only PowerEdge M630 server modules:
 - Install 86 mm width heat sink for processors of 120 W or more
 - Install 68 mm width heat sink for processors of less than 120 W.
 - If you install a blade with two processors in the M1000e enclosure, all blade slots in the enclosure must have PowerEdge M630 blades with the same configuration (PowerEdge M630 blades with two processors). However, vacant blade slots in the enclosure can be installed with blade blanks.

Initial system setup and configuration

Setting up your system

Complete the following steps to set up your system:

- 1 Unpack the server module.
- 2 Remove the I/O connector cover from the server module connectors.

 **CAUTION:** While installing the server module, ensure that it is properly aligned with the slot on the enclosure to prevent damage to the server module connectors.

- 3 Install the server module in the enclosure.
- 4 Turn on the enclosure.

 **NOTE:** Wait for the chassis to initialize before you press the power button.

- 5 Turn on the server module by pressing the power button on the server module.

Alternatively, you can also turn on the server module by using:

- The server module iDRAC. For more information, see the Log in to iDRAC section.
- The enclosure Chassis Management Controller (CMC), after the server module iDRAC is configured on the CMC. For more information, see the *CMC User's Guide* at Dell.com/idracmanuals.

Related links

[Log in to iDRAC](#)

[Installing a server module](#)

iDRAC configuration

The Integrated Dell Remote Access Controller (iDRAC) is designed to make system administrators more productive and improve the overall availability of Dell systems. iDRAC alerts administrators to system issues, helps them perform remote system management, and reduces the need for physical access to the system.

Options to set up iDRAC IP address

You must configure the initial network settings based on your network infrastructure to enable the communication to and from iDRAC. You can set up the IP address by using one of the following interfaces:

Interfaces	Document/Section
iDRAC Settings utility	See <i>Dell Integrated Dell Remote Access Controller User's Guide</i> at Dell.com/idracmanuals
Dell Deployment Toolkit	See <i>Dell Deployment Toolkit User's Guide</i> at Dell.com/openmanagemanuals
Dell Lifecycle Controller	See <i>Dell Lifecycle Controller User's Guide</i> at Dell.com/idracmanuals
CMC Web interface	See <i>Dell Chassis Management Controller Firmware User's Guide</i> at Dell.com/esmmanuals

You must use the default iDRAC IP address 192.168.0.120 to configure the initial network settings, including setting up DHCP or a static IP for iDRAC.

- ① **NOTE:** To access iDRAC, ensure that you install the iDRAC port card or connect the network cable to the Ethernet connector 1 on the system board.
- ① **NOTE:** Ensure that you change the default user name and password after setting up the iDRAC IP address.
- ① **NOTE:** In case of server module, you can configure the network setting by using the Chassis LCD panel only during initial configuration of CMC. After the chassis is deployed, you cannot reconfigure iDRAC by using the Chassis LCD panel.

Log in to iDRAC

You can log in to iDRAC as:

- iDRAC user
- Microsoft Active Directory user
- Lightweight Directory Access Protocol (LDAP) user

The default user name and password are `root` and `calvin`. You can also log in by using Single Sign-On or Smart Card.

- ① **NOTE:** You must have iDRAC credentials to log in to iDRAC.

For more information about logging in to iDRAC and iDRAC licenses, see the *Integrated Dell Remote Access Controller User's Guide* at Dell.com/idracmanuals.

Options to install the operating system

If the system is shipped without an operating system, install the supported operating system by using one of the following resources:

Table 19. Resources to install the operating system

Resources	Location
Dell Systems Management Tools and Documentation media	Dell.com/operatingsystemmanuals
Dell Lifecycle Controller	Dell.com/idracmanuals
Dell OpenManage Deployment Toolkit	Dell.com/openmanagemanuals
Dell certified VMware ESXi	Dell.com/virtualizationsolutions
Supported operating systems on Dell PowerEdge systems	Dell.com/ossupport
Installation and How-to videos for supported operating systems on Dell PowerEdge systems	Supported Operating Systems for Dell PowerEdge Systems

Methods to download firmware and drivers

You can download the firmware and drivers by using the following methods:

Table 20. Firmware and drivers

Methods	Location
From the Dell Support site	Dell.com/support/home
Using Dell Remote Access Controller Lifecycle Controller (iDRAC with LC)	Dell.com/idracmanuals
Using Dell Repository Manager (DRM)	Dell.com/openmanagemanuals
Using Dell OpenManage Essentials (OME)	Dell.com/openmanagemanuals
Using Dell Server Update Utility (SUU)	Dell.com/openmanagemanuals
Using Dell OpenManage Deployment Toolkit (DTK)	Dell.com/openmanagemanuals

Downloading the drivers and firmware

Dell recommends that you download and install the latest BIOS, drivers, and systems management firmware on your system.

Prerequisite

Ensure that you clear the web browser cache before downloading the drivers and firmware.

Steps

- 1 Go to **Dell.com/support/drivers**.
- 2 Under the **Drivers & Downloads** section, type the Service Tag of your system in the **Service Tag or Express Service Code** box.

 **NOTE:** If you do not have the Service Tag, select **Detect My Product** to allow the system to automatically detect your Service Tag, or under **General support**, navigate to your product.

- 3 Click **Drivers & Downloads**.
The drivers that are applicable to your selection are displayed.
- 4 Download the drivers you need to a USB drive, CD, or DVD.

Pre-operating system management applications

You can manage basic settings and features of a system without booting to the operating system by using the system firmware.

Options to manage the pre-operating system applications

Your system has the following options to manage the pre-operating system applications:

- System Setup
- Boot Manager
- Dell Lifecycle Controller
- Preboot Execution Environment (PXE)

Related links

- [System Setup](#)
- [Boot Manager](#)
- [Dell Lifecycle Controller](#)
- [PXE boot](#)

System Setup

By using the **System Setup** screen, you can configure the BIOS settings, iDRAC settings, and device settings of your system.

NOTE: Help text for the selected field is displayed in the graphical browser by default. To view the help text in the text browser, press F1.

You can access system setup by using two methods:

- Standard graphical browser—The browser is enabled by default.
- Text browser—The browser is enabled by using Console Redirection.

Related links

- [System Setup details](#)
- [Viewing System Setup](#)

Viewing System Setup

To view the **System Setup** screen, perform the following steps:

- 1 Turn on, or restart your system.
- 2 Press F2 immediately after you see the following message:
F2 = System Setup

NOTE: If your operating system begins to load before you press F2, wait for the system to finish booting, and then restart your system and try again.

Related links

- [System Setup](#)
- [System Setup details](#)
- [System BIOS](#)
- [iDRAC Settings utility](#)
- [Device Settings](#)

System Setup details

The **System Setup Main Menu** screen details are explained as follows:

Option	Description
System BIOS	Enables you to configure BIOS settings.
iDRAC Settings	Enables you to configure iDRAC settings. The iDRAC settings utility is an interface to set up and configure the iDRAC parameters by using UEFI (Unified Extensible Firmware Interface). You can enable or disable various iDRAC parameters by using the iDRAC settings utility. For more information about this utility, see <i>Integrated Dell Remote Access Controller User's Guide</i> at Dell.com/idracmanuals .
Device Settings	Enables you to configure device settings.

Related links

- [System Setup](#)
- [Viewing System Setup](#)

System BIOS

You can use the **System BIOS** screen to edit specific functions such as boot order, system password, setup password, set the RAID mode, and enable or disable USB ports.

Related links

- [System BIOS Settings details](#)
- [Boot Settings](#)
- [Network Settings](#)
- [System Security](#)
- [System Information](#)
- [Memory Settings](#)
- [Processor Settings](#)
- [SATA Settings](#)
- [Integrated Devices](#)
- [Serial Communication](#)
- [System Profile Settings](#)
- [Miscellaneous Settings](#)
- [iDRAC Settings utility](#)
- [Device Settings](#)
- [Viewing System BIOS](#)

Viewing System BIOS

To view the **System BIOS** screen, perform the following steps:

- 1 Turn on, or restart your system.
- 2 Press F2 immediately after you see the following message:

F2 = System Setup

NOTE: If your operating system begins to load before you press F2, wait for the system to finish booting, and then restart your system and try again.

- 3 On the **System Setup Main Menu** screen, click **System BIOS**.

Related links

[System BIOS](#)

[System BIOS Settings details](#)

System BIOS Settings details

The **System BIOS Settings** screen details are explained as follows:

Option	Description
System Information	Specifies information about the system such as the system model name, BIOS version, and Service Tag.
Memory Settings	Specifies information and options related to the installed memory.
Processor Settings	Specifies information and options related to the processor such as speed and cache size.
SATA Settings	Specifies options to enable or disable the integrated SATA controller and ports.
Boot Settings	Specifies options to specify the boot mode (BIOS or UEFI). Enables you to modify UEFI and BIOS boot settings.
Network Settings	Specifies options to change the network settings.
Integrated Devices	Specifies options to manage integrated device controllers and ports and specify related features and options.
Serial Communication	Specifies options to manage the serial ports and specify related features and options.
System Profile Settings	Specifies options to change the processor power management settings, memory frequency, and so on.
System Security	Specifies options to configure the system security settings, such as system password, setup password, Trusted Platform Module (TPM) security. It also manages the power and NMI buttons on the system.
Miscellaneous Settings	Specifies options to change the system date, time, and so on.

Related links

[System BIOS](#)

[Viewing System BIOS](#)

Boot Settings

You can use the **Boot Settings** screen to set the boot mode to either **BIOS** or **UEFI**. It also enables you to specify the boot order.

Related links

- [Boot Settings details](#)
- [System BIOS](#)
- [Viewing Boot Settings](#)
- [Choosing the system boot mode](#)
- [Changing the boot order](#)

Viewing Boot Settings

To view the **Boot Settings** screen, perform the following steps:

- 1 Turn on, or restart your system.
- 2 Press F2 immediately after you see the following message:

F2 = System Setup

NOTE: If your operating system begins to load before you press F2, wait for the system to finish booting, and then restart your system and try again.

- 3 On the **System Setup Main Menu** screen, click **System BIOS**.
- 4 On the **System BIOS** screen, click **Boot Settings**.

Related links

- [Boot Settings](#)
- [Boot Settings details](#)
- [Choosing the system boot mode](#)
- [Changing the boot order](#)

Boot Settings details

The **Boot Settings** screen details are explained as follows:

Option	Description
Boot Mode	<p>Enables you to set the boot mode of the system.</p> <p>CAUTION: Switching the boot mode may prevent the system from booting if the operating system is not installed in the same boot mode.</p> <p>If the operating system supports UEFI, you can set this option to UEFI. Setting this field to BIOS allows compatibility with non-UEFI operating systems. This option is set to BIOS by default.</p> <p>NOTE: Setting this field to UEFI disables the BIOS Boot Settings menu. Setting this field to BIOS disables the UEFI Boot Settings menu.</p>
Boot Sequence Retry	<p>Enables or disables the Boot Sequence Retry feature. If this option is set to Enabled and the system fails to boot, the system reattempts the boot sequence after 30 seconds. This option is set to Enabled by default.</p>
Hard-Disk Failover	<p>Specifies the hard drive that is booted in the event of a hard drive failure. The devices are selected in the Hard-Disk Drive Sequence on the Boot Option Setting menu. When this option is set to Disabled, only the first hard drive in the list is attempted to boot. When this option is set to Enabled, all hard drives are attempted to boot in the order selected in the Hard-Disk Drive Sequence. This option is not enabled for UEFI Boot Mode.</p>
Boot Option Settings	<p>Configures the boot sequence and the boot devices.</p>

Related links

- [Boot Settings](#)
- [Viewing Boot Settings](#)
- [Choosing the system boot mode](#)
- [Changing the boot order](#)

Choosing the system boot mode

System Setup enables you to specify one of the following boot modes for installing your operating system:

- BIOS boot mode (the default) is the standard BIOS-level boot interface.
- Unified Extensible Firmware Interface (UEFI) boot mode is an enhanced 64-bit boot interface. If you have configured your system to boot to UEFI mode, it replaces the system BIOS.

- 1 From the **System Setup Main Menu**, click **Boot Settings**, and select **Boot Mode**.
- 2 Select the boot mode you want the system to boot into.

 **CAUTION:** Switching the boot mode may prevent the system from booting if the operating system is not installed in the same boot mode.

- 3 After the system boots in the specified boot mode, proceed to install your operating system from that mode.

 **NOTE:** Operating systems must be UEFI-compatible to be installed from the UEFI boot mode. DOS and 32-bit operating systems do not support UEFI and can only be installed from the BIOS boot mode.

 **NOTE:** For the latest information about supported operating systems, go to Dell.com/ossupport.

Related links

- [Boot Settings](#)
- [Boot Settings details](#)
- [Viewing Boot Settings](#)

Changing the boot order

You may have to change the boot order if you want to boot from a USB key or an optical drive. The following instructions may vary if you have selected **BIOS** for **Boot Mode**.

- 1 On the **System Setup Main Menu** screen, click **System BIOS > Boot Settings**.
- 2 Click **Boot Option Settings > Boot Sequence**.
- 3 Use the arrow keys to select a boot device, and use the plus (+) and minus (-) sign keys to move the device down or up in the order.
- 4 Click **Exit**, and then click **Yes** to save the settings on exit.

Related links

- [Boot Settings](#)
- [Boot Settings details](#)
- [Viewing Boot Settings](#)

Network Settings

You can use the **Network Settings** screen to modify PXE device settings. The network settings option is available only in the UEFI mode.

 **NOTE:** The BIOS does not control network settings in the BIOS mode. For the BIOS boot mode, the optional Boot ROM of the network controllers handles the network settings.

Related links

- [Network Settings screen details](#)
- [System BIOS](#)
- [Viewing Network Settings](#)

Viewing Network Settings

To view the **Network Settings** screen, perform the following steps:

- 1 Turn on, or restart your system.
- 2 Press F2 immediately after you see the following message:

F2 = System Setup

NOTE: If your operating system begins to load before you press F2, wait for the system to finish booting, and then restart your system and try again.

- 3 On the **System Setup Main Menu** screen, click **System BIOS**.
- 4 On the **System BIOS** screen, click **Network Settings**.

Related links

[Network Settings](#)

[Network Settings screen details](#)

Network Settings screen details

The **Network Settings** screen details are explained as follows:

Option	Description
PXE Device n (n = 1 to 4)	Enables or disables the device. When enabled, a UEFI boot option is created for the device.
PXE Device n Settings (n = 1 to 4)	Enables you to control the configuration of the PXE device.

Related links

[Network Settings](#)

[Viewing Network Settings](#)

System Security

You can use the **System Security** screen to perform specific functions such as setting the system password, setup password and disabling the power button.

Related links

[System Security Settings details](#)

[Operating with a setup password enabled](#)

[System BIOS](#)

[Viewing System Security](#)

[Creating a system and setup password](#)

[Using your system password to secure your system](#)

[Deleting or changing system and setup password](#)

Viewing System Security

To view the **System Security** screen, perform the following steps:

- 1 Turn on, or restart your system.
- 2 Press F2 immediately after you see the following message:

F2 = System Setup

NOTE: If your operating system begins to load before you press F2, wait for the system to finish booting, and then restart your system and try again.

- 3 On the **System Setup Main Menu** screen, click **System BIOS**.
- 4 On the **System BIOS** screen, click **System Security**.

Related links

- [System Security](#)
- [System Security Settings details](#)

System Security Settings details

The **System Security Settings** screen details are explained as follows:

Option	Description
Intel AES-NI	Improves the speed of applications by performing encryption and decryption by using the Advanced Encryption Standard Instruction Set (AES-NI). This option is set to Enabled by default.
System Password	Sets the system password. This option is set to Enabled by default and is read-only if the password jumper is not installed in the system.
Setup Password	Sets the setup password. This option is read-only if the password jumper is not installed in the system.
Password Status	Locks the system password. This option is set to Unlocked by default.
TPM Security	<p>NOTE: The TPM menu is available only when the TPM module is installed.</p> <p>Enables you to control the reporting mode of the TPM. The TPM Security option is set to Off by default. You can only modify the TPM Status, TPM Activation, and Intel TXT fields if the TPM Status field is set to either On with Pre-boot Measurements or On without Pre-boot Measurements.</p>
TPM Information	Changes the operational state of the TPM. This option is set to No Change by default.
TPM Status	Specifies the TPM status.
TPM Command	<p>CAUTION: Clearing the TPM results in the loss of all keys in the TPM. The loss of TPM keys may affect booting to the operating system.</p> <p>Clears all the contents of the TPM. The TPM Clear option is set to No by default.</p>
Intel TXT	Enables or disables the Intel Trusted Execution Technology (TXT) option. To enable the Intel TXT option, virtualization technology and TPM Security must be enabled with Pre-boot measurements. This option is set to Off by default.
Power Button	Enables or disables the power button on the front of the system. This option is set to Enabled by default.
AC Power Recovery	Sets how the system behaves after AC power is restored to the system. This option is set to Last by default.
UEFI Variable Access	Provides varying degrees of securing UEFI variables. When set to Standard (the default), UEFI variables are accessible in the operating system per the UEFI specification. When set to Controlled , selected UEFI variables are protected in the environment and new UEFI boot entries are forced to be at the end of the current boot order.
Secure Boot	Enables Secure Boot, where the BIOS authenticates each pre-boot image by using the certificates in the Secure Boot Policy. Secure Boot is disabled by default.
Secure Boot Policy	When Secure Boot policy is set to Standard , the BIOS uses the system manufacturer's key and certificates to authenticate pre-boot images. When Secure Boot policy is set to Custom , the BIOS uses the user-defined key and certificates. Secure Boot policy is set to Standard by default.
Secure Boot Policy Summary	Specifies the list of certificates and hashes that secure boot uses to authenticate images.

Related links

- [System Security](#)
- [Viewing System Security](#)

Secure Boot Custom Policy Settings

Secure Boot Custom Policy Settings is displayed only when **Secure Boot Policy** is set to **Custom**.

Viewing Secure Boot Custom Policy Settings

To view the **Secure Boot Custom Policy Settings** screen, perform the following steps:

- 1 Turn on, or restart your system.
- 2 Press F2 immediately after you see the following message:

F2 = System Setup

NOTE: If your operating system begins to load before you press F2, wait for the system to finish booting, and then restart your system and try again.

- 3 On the **System Setup Main Menu** screen, click **System BIOS**.
- 4 On the **System BIOS** screen, click **System Security**.
- 5 On the **System Security** screen, click **Secure Boot Custom Policy Settings**.

Secure Boot Custom Policy Settings details

The **Secure Boot Custom Policy Settings** screen details are explained as follows:

Option	Description
Platform Key	Imports, exports, deletes, or restores the platform key (PK).
Key Exchange Key Database	Enables you to import, export, delete, or restore entries in the Key Exchange Key (KEK) Database.
Authorized Signature Database	Imports, exports, deletes, or restores entries in the Authorized Signature Database (db).
Forbidden Signature Database	Imports, exports, deletes, or restores entries in the Forbidden Signature Database (dbx).

Creating a system and setup password

Prerequisite

Ensure that the password jumper is enabled. The password jumper enables or disables the system password and setup password features. For more information, see the System board jumper settings section.

NOTE: If the password jumper setting is disabled, the existing system password and setup password are deleted and you need not provide the system password to boot the system.

Steps

- 1 To enter System Setup, press F2 immediately after turning on or rebooting your system.
- 2 On the **System Setup Main Menu** screen, click **System BIOS > System Security**.
- 3 On the **System Security** screen, verify that **Password Status** is set to **Unlocked**.
- 4 In the **System Password** field, type your system password, and press Enter or Tab.

Use the following guidelines to assign the system password:

- A password can have up to 32 characters.
- The password can contain the numbers 0 through 9.
- Only the following special characters are allowed: space, ("), (+), (,), (-), (.), (/), (:), ([), (\), (]), (`).

A message prompts you to reenter the system password.

- 5 Reenter the system password, and click **OK**.

- In the **Setup Password** field, type your setup password and press Enter or Tab.
A message prompts you to reenter the setup password.
- Reenter the setup password, and click **OK**.
- Press Esc to return to the System BIOS screen. Press Esc again.
A message prompts you to save the changes.

NOTE: Password protection does not take effect until the system reboots.

Related link

[System Security](#)

Using your system password to secure your system

If you have assigned a setup password, the system accepts your setup password as an alternate system password.

Steps

- Turn on or reboot your system.
- Type the system password and press Enter.

Next step

When **Password Status** is set to **Locked**, type the system password and press Enter when prompted at reboot.

NOTE: If an incorrect system password is typed, the system displays a message and prompts you to reenter your password. You have three attempts to type the correct password. After the third unsuccessful attempt, the system displays an error message that the system has stopped functioning and must be turned off. Even after you turn off and restart the system, the error message is displayed until the correct password is entered.

Related link

[System Security](#)

Deleting or changing system and setup password

Prerequisite

NOTE: You cannot delete or change an existing system or setup password if the **Password Status** is set to **Locked**.

Steps

- To enter System Setup, press F2 immediately after turning on or restarting your system.
- On the **System Setup Main Menu** screen, click **System BIOS > System Security**.
- On the **System Security** screen, ensure that **Password Status** is set to **Unlocked**.
- In the **System Password** field, alter or delete the existing system password, and then press Enter or Tab.
- In the **Setup Password** field, alter or delete the existing setup password, and then press Enter or Tab.
If you change the system and setup password, a message prompts you to reenter the new password. If you delete the system and setup password, a message prompts you to confirm the deletion.
- Press Esc to return to the **System BIOS** screen. Press Esc again, and a message prompts you to save the changes.

Related link

[System Security](#)

Operating with a setup password enabled

If **Setup Password** is set to **Enabled**, type the correct setup password before modifying the system setup options.

If you do not type the correct password in three attempts, the system displays the following message:

```
Invalid Password! Number of unsuccessful password attempts: <x> System Halted! Must power down.
```

Even after you turn off and restart the system, the error message is displayed until the correct password is typed. The following options are exceptions:

- If **System Password** is not set to **Enabled** and is not locked through the **Password Status** option, you can assign a system password. For more information, see the System Security Settings screen section.
- You cannot disable or change an existing system password.

NOTE: You can use the password status option with the setup password option to protect the system password from unauthorized changes.

Related link

[System Security](#)

System Information

You can use the **System Information** screen to view system properties such as Service Tag, system model name, and the BIOS version.

Related links

[System Information details](#)

[System BIOS](#)

[Viewing System Information](#)

Viewing System Information

To view the **System Information** screen, perform the following steps:

- 1 Turn on, or restart your system.
- 2 Press F2 immediately after you see the following message:

F2 = System Setup

NOTE: If your operating system begins to load before you press F2, wait for the system to finish booting, and then restart your system and try again.

- 3 On the **System Setup Main Menu** screen, click **System BIOS**.
- 4 On the **System BIOS** screen, click **System Information**.

Related link

[System Information](#)

System Information details

The **System Information** screen details are explained as follows:

Option	Description
System Model Name	Specifies the system model name.
System BIOS Version	Specifies the BIOS version installed on the system.
System Management Engine Version	Specifies the current version of the Management Engine firmware.
System Service Tag	Specifies the system Service Tag.
System Manufacturer	Specifies the name of the system manufacturer.

Option	Description
System Manufacturer Contact Information	Specifies the contact information of the system manufacturer.
System CPLD Version	Specifies the current version of the system complex programmable logic device (CPLD) firmware.
UEFI Compliance Version	Specifies the UEFI compliance level of the system firmware.

Related links

- [System Information](#)
- [System Information details](#)
- [Viewing System Information](#)

Memory Settings

You can use the **Memory Settings** screen to view all the memory settings and enable or disable specific memory functions, such as system memory testing and node interleaving.

Related links

- [Memory Settings details](#)
- [System BIOS](#)
- [Viewing Memory Settings](#)

Viewing Memory Settings

To view the **Memory Settings** screen, perform the following steps:

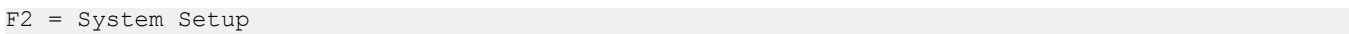
- 1 Turn on, or restart your system.
- 2 Press F2 immediately after you see the following message:

- 3 On the **System Setup Main Menu** screen, click **System BIOS**.
- 4 On the **System BIOS** screen, click **Memory Settings**.

NOTE: If your operating system begins to load before you press F2, wait for the system to finish booting, and then restart your system and try again.

Related links

- [Memory Settings](#)
- [Memory Settings details](#)

Memory Settings details

The **Memory Settings** screen details are explained as follows:

Option	Description
System Memory Size	Specifies the memory size in the system.
System Memory Type	Specifies the type of memory installed in the system.
System Memory Speed	Specifies the system memory speed.

Option	Description
System Memory Voltage	Specifies the system memory voltage.
Video Memory	Specifies the amount of video memory.
System Memory Testing	Specifies whether the system memory tests are run during system boot. Options are Enabled and Disabled . This option is set to Disabled by default.
Memory Operating Mode	Specifies the memory operating mode. The options available are Optimizer Mode , Advanced ECC Mode , Mirror Mode , Spare Mode , Spare with Advanced ECC Mode , Dell Fault Resilient Mode and Dell NUMA Fault Resilient Mode . This option is set to Optimizer Mode by default. <p>NOTE: The Memory Operating Mode option can have different default and available options based on the memory configuration of your system.</p> <p>NOTE: The Dell Fault Resilient Mode option establishes an area of memory that is fault resilient. This mode can be used by an operating system that supports the feature to load critical applications or enables the operating system kernel to maximize system availability.</p>
Node Interleaving	Specifies if Non-Uniform Memory architecture (NUMA) is supported. If this field is set to Enabled , memory interleaving is supported if a symmetric memory configuration is installed. If the field is set to Disabled , the system supports NUMA (asymmetric) memory configurations. This option is set to Disabled by default.
Snoop Mode	Specifies the Snoop Mode options. The Snoop Mode options available are Home Snoop , Early Snoop , and Cluster on Die . This option is set to Early Snoop by default. This field is available only when the Node Interleaving is set to Disabled .

Related links

- [Memory Settings](#)
- [Viewing Memory Settings](#)

Processor Settings

You can use the **Processor Settings** screen to view the processor settings, and perform specific functions such as enabling virtualization technology, hardware prefetcher, and logical processor idling.

Related links

- [Processor Settings details](#)
- [System BIOS](#)
- [Viewing Processor Settings](#)

Viewing Processor Settings

To view the **Processor Settings** screen, perform the following steps:

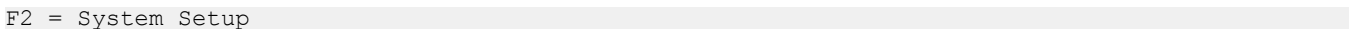
- 1 Turn on, or restart your system.
- 2 Press F2 immediately after you see the following message:

NOTE: If your operating system begins to load before you press F2, wait for the system to finish booting, and then restart your system and try again.





- 3 On the **System Setup Main Menu** screen, click **System BIOS**.
- 4 On the **System BIOS** screen, click **Processor Settings**.

Related links

- [Processor Settings](#)
- [Processor Settings details](#)

Processor Settings details

The **Processor Settings** screen details are explained as follows:

Option	Description
Logical Processor	Enables or disables the logical processors and displays the number of logical processors. If this option is set to Enabled , the BIOS displays all the logical processors. If this option is set to Disabled , the BIOS displays only one logical processor per core. This option is set to Enabled by default.
QPI Speed	Enables you to control QuickPath Interconnect data rate settings.
Alternate RTID (Requestor Transaction ID) Setting	Modifies Requestor Transaction IDs, which are QPI resources. This option is set to Disabled by default.  NOTE: Enabling this option may negatively impact the overall system performance.
Virtualization Technology	Enables or disables the additional hardware capabilities provided for virtualization. This option is set to Enabled by default.
Address Translation Service (ATS)	Defines the Address Translation Cache (ATC) for devices to cache the DMA transactions. This option provides an interface between CPU and DMA Memory Management to a chipset's Address Translation and Protection Table to translate DMA addresses to host addresses. This option is set to Enabled by default.
Adjacent Cache Line Prefetch	Optimizes the system for applications that need high utilization of sequential memory access. This option is set to Enabled by default. You can disable this option for applications that need high utilization of random memory access.
Hardware Prefetcher	Enables or disables the hardware prefetcher. This option is set to Enabled by default.
DCU Streamer Prefetcher	Enables or disables the Data Cache Unit (DCU) streamer prefetcher. This option is set to Enabled by default.
DCU IP Prefetcher	Enables or disables the Data Cache Unit (DCU) IP prefetcher. This option is set to Enabled by default.
Execute Disable	Enables you to run the disable memory protection technology. This option is set to Enabled by default.
Logical Processor Idling	Enables you to improve the energy efficiency of a system. It uses the operating system core parking algorithm and parks some of the logical processors in the system which in turn allows the corresponding processor cores to transition into a lower power idle state. This option can only be enabled if the operating system supports it. It is set to Disabled by default.
Configurable TDP	Enables you to reconfigure the processor Thermal Design Power (TDP) levels during POST based on the power and thermal delivery capabilities of the system. TDP verifies the maximum heat the cooling system is needed to dissipate. This option is set to Nominal by default.  NOTE: This option is only available on certain stock keeping units (SKUs) of the processors.
X2Apic Mode	Enables or disables the X2Apic mode.
Dell Controlled Turbo	Controls the turbo engagement. Enable this option only when System Profile is set to Performance .  NOTE: Depending on the number of installed CPUs, there may be up to four processor listings.
Number of Cores per Processor	Controls the number of enabled cores in each processor. This option is set to All by default.
Processor 64-bit Support	Specifies if the processor(s) support 64-bit extensions.
Processor Core Speed	Specifies the maximum core frequency of the processor.
Processor 1	 NOTE: Depending on the number of CPUs, there may be up to four processors listed.

Option

Description

The following settings are displayed for each processor installed in the system:

Option	Description
Family-Model-Stepping	Specifies the family, model, and stepping of the processor as defined by Intel.
Brand	Specifies the brand name.
Level 2 Cache	Specifies the total L2 cache.
Level 3 Cache	Specifies the total L3 cache.
Number of Cores	Specifies the number of cores per processor.

Related links

- [Processor Settings](#)
- [Viewing Processor Settings](#)

SATA Settings

You can use the **SATA Settings** screen to view the SATA settings of SATA devices and enable RAID on your system.

Related links

- [SATA Settings details](#)
- [System BIOS](#)
- [Viewing SATA Settings](#)

Viewing SATA Settings

To view the **SATA Settings** screen, perform the following steps:

- 1 Turn on, or restart your system.
- 2 Press F2 immediately after you see the following message:
F2 = System Setup

NOTE: If your operating system begins to load before you press F2, wait for the system to finish booting, and then restart your system and try again.

- 3 On the **System Setup Main Menu** screen, click **System BIOS**.
- 4 On the **System BIOS** screen, click **SATA Settings**.

Related links

- [SATA Settings](#)
- [SATA Settings details](#)

SATA Settings details

The **SATA Settings** screen details are explained as follows:

Option

Description

Embedded SATA

Enables the embedded SATA option to be set to **Off**, **ATA**, **AHCI**, or **RAID** modes. This option is set to **AHCI** by default.

Security Freeze Lock

Sends Security Freeze Lock command to the Embedded SATA drives during POST. This option is applicable only for ATA and AHCI modes.

Write Cache

Enables or disables the command for Embedded SATA drives during POST.

Option **Description**

Port A Sets the drive type of the selected device. For **Embedded SATA settings** in **ATA** mode, set this field to **Auto** to enable BIOS support. Set it to **OFF** to turn off BIOS support.
For **AHCI** or **RAID** mode, BIOS support is always enabled.

Option	Description
Model	Specifies the drive model of the selected device.
Drive Type	Specifies the type of drive attached to the SATA port.
Capacity	Specifies the total capacity of the hard drive. This field is undefined for removable media devices such as optical drives.

Port B Sets the drive type of the selected device. For **Embedded SATA settings** in **ATA** mode, set this field to **Auto** to enable BIOS support. Set it to **OFF** to turn off BIOS support.
For **AHCI** or **RAID** mode, BIOS support is always enabled.

Option	Description
Model	Specifies the drive model of the selected device.
Drive Type	Specifies the type of drive attached to the SATA port.
Capacity	Specifies the total capacity of the hard drive. This field is undefined for removable media devices such as optical drives.

Port C Sets the drive type of the selected device. For **Embedded SATA settings** in **ATA** mode, set this field to **Auto** to enable BIOS support. Set it to **OFF** to turn off BIOS support.
For **AHCI** or **RAID** mode, BIOS support is always enabled.

Option	Description
Model	Specifies the drive model of the selected device.
Drive Type	Specifies the type of drive attached to the SATA port.
Capacity	Specifies the total capacity of the hard drive. This field is undefined for removable media devices such as optical drives.

Port D Sets the drive type of the selected device. For **Embedded SATA settings** in **ATA** mode, set this field to **Auto** to enable BIOS support. Set it to **OFF** to turn off BIOS support.
For **AHCI** or **RAID** mode, BIOS support is always enabled.

Option	Description
Model	Specifies the drive model of the selected device.
Drive Type	Specifies the type of drive attached to the SATA port.
Capacity	Specifies the total capacity of the hard drive. This field is undefined for removable media devices such as optical drives.

Port E Sets the drive type of the selected device. For **Embedded SATA settings** in **ATA** mode, set this field to **Auto** to enable BIOS support. Set it to **OFF** to turn off BIOS support.
For **AHCI** or **RAID** mode, BIOS support is always enabled.

Option	Description
Model	Specifies the drive model of the selected device.

Option	<table border="0"> <tr> <td style="vertical-align: top;">Description</td> <td></td> </tr> <tr> <td style="vertical-align: top;">Option</td> <td style="vertical-align: top;">Description</td> </tr> <tr> <td style="vertical-align: top;">Drive Type</td> <td>Specifies the type of drive attached to the SATA port.</td> </tr> <tr> <td style="vertical-align: top;">Capacity</td> <td>Specifies the total capacity of the hard drive. This field is undefined for removable media devices such as optical drives.</td> </tr> </table>	Description		Option	Description	Drive Type	Specifies the type of drive attached to the SATA port.	Capacity	Specifies the total capacity of the hard drive. This field is undefined for removable media devices such as optical drives.
Description									
Option	Description								
Drive Type	Specifies the type of drive attached to the SATA port.								
Capacity	Specifies the total capacity of the hard drive. This field is undefined for removable media devices such as optical drives.								
Port F	<p>Sets the drive type of the selected device. For Embedded SATA settings in ATA mode, set this field to Auto to enable BIOS support. Set it to OFF to turn off BIOS support.</p> <p>For AHCI or RAID mode, BIOS support is always enabled.</p> <table border="0"> <tr> <td style="vertical-align: top;">Option</td> <td style="vertical-align: top;">Description</td> </tr> <tr> <td style="vertical-align: top;">Model</td> <td>Specifies the drive model of the selected device.</td> </tr> <tr> <td style="vertical-align: top;">Drive Type</td> <td>Specifies the type of drive attached to the SATA port.</td> </tr> <tr> <td style="vertical-align: top;">Capacity</td> <td>Specifies the total capacity of the hard drive. This field is undefined for removable media devices such as optical drives.</td> </tr> </table>	Option	Description	Model	Specifies the drive model of the selected device.	Drive Type	Specifies the type of drive attached to the SATA port.	Capacity	Specifies the total capacity of the hard drive. This field is undefined for removable media devices such as optical drives.
Option	Description								
Model	Specifies the drive model of the selected device.								
Drive Type	Specifies the type of drive attached to the SATA port.								
Capacity	Specifies the total capacity of the hard drive. This field is undefined for removable media devices such as optical drives.								
Port G	<p>Sets the drive type of the selected device. For Embedded SATA settings in ATA mode, set this field to Auto to enable BIOS support. Set it to OFF to turn off BIOS support.</p> <p>For AHCI or RAID mode, BIOS support is always enabled.</p> <table border="0"> <tr> <td style="vertical-align: top;">Option</td> <td style="vertical-align: top;">Description</td> </tr> <tr> <td style="vertical-align: top;">Model</td> <td>Specifies the drive model of the selected device.</td> </tr> <tr> <td style="vertical-align: top;">Drive Type</td> <td>Specifies the type of drive attached to the SATA port.</td> </tr> <tr> <td style="vertical-align: top;">Capacity</td> <td>Specifies the total capacity of the hard drive. This field is undefined for removable media devices such as optical drives.</td> </tr> </table>	Option	Description	Model	Specifies the drive model of the selected device.	Drive Type	Specifies the type of drive attached to the SATA port.	Capacity	Specifies the total capacity of the hard drive. This field is undefined for removable media devices such as optical drives.
Option	Description								
Model	Specifies the drive model of the selected device.								
Drive Type	Specifies the type of drive attached to the SATA port.								
Capacity	Specifies the total capacity of the hard drive. This field is undefined for removable media devices such as optical drives.								
Port H	<p>Sets the drive type of the selected device. For Embedded SATA settings in ATA mode, set this field to Auto to enable BIOS support. Set it to OFF to turn off BIOS support.</p> <p>For AHCI or RAID mode, BIOS support is always enabled.</p> <table border="0"> <tr> <td style="vertical-align: top;">Option</td> <td style="vertical-align: top;">Description</td> </tr> <tr> <td style="vertical-align: top;">Model</td> <td>Specifies the drive model of the selected device.</td> </tr> <tr> <td style="vertical-align: top;">Drive Type</td> <td>Specifies the type of drive attached to the SATA port.</td> </tr> <tr> <td style="vertical-align: top;">Capacity</td> <td>Specifies the total capacity of the hard drive. This field is undefined for removable media devices such as optical drives.</td> </tr> </table>	Option	Description	Model	Specifies the drive model of the selected device.	Drive Type	Specifies the type of drive attached to the SATA port.	Capacity	Specifies the total capacity of the hard drive. This field is undefined for removable media devices such as optical drives.
Option	Description								
Model	Specifies the drive model of the selected device.								
Drive Type	Specifies the type of drive attached to the SATA port.								
Capacity	Specifies the total capacity of the hard drive. This field is undefined for removable media devices such as optical drives.								
Port I	<p>Sets the drive type of the selected device. For Embedded SATA settings in ATA mode, set this field to Auto to enable BIOS support. Set it to OFF to turn off BIOS support.</p> <p>For AHCI or RAID mode, BIOS support is always enabled.</p> <table border="0"> <tr> <td style="vertical-align: top;">Option</td> <td style="vertical-align: top;">Description</td> </tr> <tr> <td style="vertical-align: top;">Model</td> <td>Specifies the drive model of the selected device.</td> </tr> <tr> <td style="vertical-align: top;">Drive Type</td> <td>Specifies the type of drive attached to the SATA port.</td> </tr> <tr> <td style="vertical-align: top;">Capacity</td> <td>Specifies the total capacity of the hard drive. This field is undefined for removable media devices such as optical drives.</td> </tr> </table>	Option	Description	Model	Specifies the drive model of the selected device.	Drive Type	Specifies the type of drive attached to the SATA port.	Capacity	Specifies the total capacity of the hard drive. This field is undefined for removable media devices such as optical drives.
Option	Description								
Model	Specifies the drive model of the selected device.								
Drive Type	Specifies the type of drive attached to the SATA port.								
Capacity	Specifies the total capacity of the hard drive. This field is undefined for removable media devices such as optical drives.								

Option	Description
Port J	Sets the drive type of the selected device. For Embedded SATA settings in ATA mode, set this field to Auto to enable BIOS support. Set it to OFF to turn off BIOS support. For AHCI or RAID mode, BIOS support is always enabled.
Option	Description
Model	Specifies the drive model of the selected device.
Drive Type	Specifies the type of drive attached to the SATA port.
Capacity	Specifies the total capacity of the hard drive. This field is undefined for removable media devices such as optical drives.

Related links

- [SATA Settings](#)
- [Viewing SATA Settings](#)

Integrated Devices

You can use the **Integrated Devices** screen to view and configure the settings of all integrated devices including the video controller, integrated RAID controller, and the USB ports.

Related links

- [Integrated Devices details](#)
- [System BIOS](#)
- [Viewing Integrated Devices](#)

Viewing Integrated Devices

To view the **Integrated Devices** screen, perform the following steps:

- 1 Turn on, or restart your system.
- 2 Press F2 immediately after you see the following message:
F2 = System Setup

NOTE: If your operating system begins to load before you press F2, wait for the system to finish booting, and then restart your system and try again.

- 3 On the **System Setup Main Menu** screen, click **System BIOS**.
- 4 On the **System BIOS** screen, click **Integrated Devices**.

Related links

- [Integrated Devices](#)
- [Integrated Devices details](#)

Integrated Devices details

The **Integrated Devices** screen details are explained as follows:

Option	Description
USB 3.0 Setting	Enables or disables the USB 3.0 support. Enable this option only if your operating system supports USB 3.0. If you disable this option, devices operate at USB 2.0 speed. USB 3.0 is enabled by default.
User Accessible USB Ports	Enables or disables the USB ports. Selecting Only Back Ports On disables the front USB ports, selecting All Ports Off disables all USB ports. The USB keyboard and mouse operate during boot process in certain operating systems. After the boot process is complete, the USB keyboard and mouse do not work if the ports are disabled.

Option	Description
	 NOTE: Selecting Only Back Ports On and All Ports Off disables the USB management port and also restricts access to iDRAC features.
Internal USB Port	Enables or disables the internal USB port. This option is set to Enabled by default.
Integrated RAID Controller	Enables or disables the integrated RAID controller. This option is set to Enabled by default.
Integrated Network Card 1	Enables or disables the integrated network card.
I/OAT DMA Engine	Enables or disables the I/OAT option. Enable only if the hardware and software support the feature.
Embedded Video Controller	Enables or disables the Embedded Video Controller option. This option is set to Enabled by default.
SR-IOV Global Enable	Enables or disables the BIOS configuration of Single Root I/O Virtualization (SR-IOV) devices. This option is set to Disabled by default.
OS Watchdog Timer	If your system stops responding, this watchdog timer aids in the recovery of your operating system. When this option is set to Enabled , the operating system initializes the timer. When this option is set to Disabled (the default), the timer does not have any effect on the system.
Memory Mapped I/O above 4 GB	Enables or disables the support for PCIe devices that need large amounts of memory. This option is set to Enabled by default.
Mezzanine Slot Disablement	The Slot Disablement feature controls the configuration of mezzanine cards installed in the specified slots. Only mezzanine card slots that are present on your system are available for control.

Related links

- [Integrated Devices](#)
- [Viewing Integrated Devices](#)

Serial Communication

You can use the **Serial Communication** screen to view the properties of the serial communication port.

Related links

- [Serial Communication details](#)
- [System BIOS](#)
- [Viewing Serial Communication](#)

Viewing Serial Communication

To view the **Serial Communication** screen, perform the following steps:

- 1 Turn on, or restart your system.
- 2 Press F2 immediately after you see the following message:

 **NOTE:** If your operating system begins to load before you press F2, wait for the system to finish booting, and then restart your system and try again.

- 3 On the **System Setup Main Menu** screen, click **System BIOS**.
- 4 On the **System BIOS** screen, click **Serial Communication**.

Related links

- [Serial Communication](#)
- [Serial Communication details](#)

Serial Communication details

The **Serial Communication** screen details are explained as follows:

Option	Description
Serial Communication	Enables the COM port or Console Redirection options. This option is set to Off by default.
Serial Port Address	Enables you to set the port address for serial devices. This option is set to Serial Device 1=COM2, Serial Device 2=COM1 by default. NOTE: You can use only Serial Device 2 for the Serial Over LAN (SOL) feature. To use console redirection by SOL, configure the same port address for console redirection and the serial device.
External Serial Connector	Enables you to associate the External Serial Connector to Serial Device 1.
Failsafe Baud Rate	Specifies the failsafe baud rate for console redirection. The BIOS attempts to determine the baud rate automatically. This failsafe baud rate is used only if the attempt fails, and the value must not be changed. This option is set to 115200 by default.
Remote Terminal Type	Sets the remote console terminal type. This option is set to VT 100/VT 220 by default.
Redirection After Boot	Enables or disables the BIOS console redirection when the operating system is loaded. This option is set to Enabled by default.

Related links

[Serial Communication](#)

[Viewing Serial Communication](#)

System Profile Settings

You can use the **System Profile Settings** screen to enable specific system performance settings such as power management.

Related links

[System Profile Settings details](#)

[System BIOS](#)

[Viewing System Profile Settings](#)

Viewing System Profile Settings

To view the **System Profile Settings** screen, perform the following steps:

- 1 Turn on, or restart your system.
- 2 Press F2 immediately after you see the following message:

F2 = System Setup

NOTE: If your operating system begins to load before you press F2, wait for the system to finish booting, and then restart your system and try again.

- 3 On the **System Setup Main Menu** screen, click **System BIOS**.
- 4 On the **System BIOS** screen, click **System Profile Settings**.



Related links

[System Profile Settings](#)

[System Profile Settings details](#)

System Profile Settings details

The **System Profile Settings** screen details are explained as follows:

Option	Description
System Profile	<p>Sets the system profile. If you set the System Profile option to a mode other than Custom, the BIOS automatically sets the rest of the options. You can only change the rest of the options if the mode is set to Custom. This option is set to Performance Per Watt Optimized (DAPC) by default. DAPC is Dell Active Power Controller.</p> <p> NOTE: All the parameters on the system profile setting screen are available only when the System Profile option is set to Custom.</p>
CPU Power Management	<p>Sets the CPU power management. This option is set to System DBPM (DAPC) by default. DBPM is Demand-Based Power Management.</p>
Memory Frequency	<p>Sets the speed of the system memory. You can select Maximum Performance, Maximum Reliability, or a specific speed.</p>
Turbo Boost	<p>Enables or disables the processor to operate in the turbo boost mode. This option is set to Enabled by default.</p>
Energy Efficient Turbo	<p>Enables or disables the Energy Efficient Turbo option.</p> <p>Energy Efficient Turbo (EET) is a mode of operation where a processor's core frequency is adjusted to be within the turbo range based on workload.</p>
C1E	<p>Enables or disables the processor to switch to a minimum performance state when it is idle. This option is set to Enabled by default.</p>
C States	<p>Enables or disables the processor to operate in all available power states. This option is set to Enabled by default.</p>
Collaborative CPU Performance Control	<p>Enables or disables the CPU power management option. When set to Enabled, the CPU power management is controlled by the OS DBPM and the System DBPM (DAPC). This option is set to Disabled by default.</p>
Memory Patrol Scrub	<p>Sets the memory patrol scrub frequency. This option is set to Standard by default.</p>
Memory Refresh Rate	<p>Sets the memory refresh rate to either 1x or 2x. This option is set to 1x by default.</p>
Uncore Frequency	<p>Enables you to select the Processor Uncore Frequency option.</p> <p>Dynamic mode enables the processor to optimize power resources across the cores and uncore during runtime. The optimization of the uncore frequency to either save power or optimize performance is influenced by the setting of the Energy Efficiency Policy option.</p>
Energy Efficient Policy	<p>Enables you to select the Energy Efficient Policy option.</p> <p>The CPU uses the setting to manipulate the internal behavior of the processor and determines whether to target higher performance or better power savings.</p>
Number of Turbo Boot Enabled Cores for Processor 1	<p> NOTE: If there are two processors installed in the system, you see an entry for Number of Turbo Boost Enabled Cores for Processor 2.</p> <p>Controls the number of turbo boost enabled cores for processor 1. The maximum number of cores is enabled by default.</p>
Monitor/Mwait	<p>Enables the Monitor/Mwait instructions in the processor. This option is set to Enabled for all system profiles, except Custom by default.</p> <p> NOTE: This option can be disabled only if the C States option in the Custom mode is set to disabled.</p>

Option	Description
	NOTE: When C States is set to Enabled in the Custom mode, changing the Monitor/Mwait setting does not impact the system power or performance.

Related links

- [System Profile Settings](#)
- [Viewing System Profile Settings](#)

Miscellaneous Settings

You can use the **Miscellaneous Settings** screen to perform specific functions such as updating the asset tag and changing the system date and time.

Related links

- [Miscellaneous Settings details](#)
- [System BIOS](#)
- [Viewing Miscellaneous Settings](#)

Viewing Miscellaneous Settings

To view the **Miscellaneous Settings** screen, perform the following steps:

- 1 Turn on, or restart your system.
- 2 Press F2 immediately after you see the following message:
F2 = System Setup

NOTE: If your operating system begins to load before you press F2, wait for the system to finish booting, and then restart your system and try again.

- 3 On the **System Setup Main Menu** screen, click **System BIOS**.
- 4 On the **System BIOS** screen, click **Miscellaneous Settings**.

Related links

- [Miscellaneous Settings](#)
- [Miscellaneous Settings details](#)

Miscellaneous Settings details

The **Miscellaneous Settings** screen details are explained as follows:

Option	Description
System Time	Enables you to set the time on the system.
System Date	Enables you to set the date on the system.
Asset Tag	Specifies the asset tag and enables you to modify it for security and tracking purposes.
Keyboard NumLock	Enables you to set whether the system boots with the NumLock enabled or disabled. This option is set to On by default. NOTE: This option does not apply to 84-key keyboards.
F1/F2 Prompt on Error	Enables or disables the F1/F2 prompt on error. This option is set to Enabled by default. The F1/F2 prompt also includes keyboard errors.
Load Legacy Video Option ROM	Enables you to determine whether the system BIOS loads the legacy video (INT 10H) option ROM from the video controller. Selecting Enabled in the operating system does not support UEFI video output standards. This field is available only for UEFI boot mode. You cannot set the option to Enabled if UEFI Secure Boot mode is enabled.

Option	Description
In-System Characterization	<p>Enables or disables In-System Characterization. This option is set to Disabled by default. The two other options are Enabled and Enabled - No Reboot.</p> <p>NOTE: The default setting for In-System Characterization is subject to change in future BIOS releases.</p> <p>When enabled, In-System Characterization (ISC) executes during POST upon detecting relevant change(s) in system configuration to optimize system power and performance. ISC takes about 20 seconds to execute, and system reset is needed for ISC results to be applied. The Enabled - No Reboot option executes ISC and continues without applying ISC results until the next time system reset occurs. The Enabled option executes ISC and forces an immediate system reset so that ISC results can be applied. It takes the system longer to be ready due to the forced system reset. When disabled, ISC does not execute.</p>

Related links

- [Miscellaneous Settings](#)
- [Viewing Miscellaneous Settings](#)

iDRAC Settings utility

The iDRAC settings utility is an interface to set up and configure the iDRAC parameters by using UEFI. You can enable or disable various iDRAC parameters by using the iDRAC settings utility.

NOTE: Accessing some of the features on the iDRAC settings utility needs the iDRAC Enterprise License upgrade.

For more information about using iDRAC, see *Dell Integrated Dell Remote Access Controller User's Guide* at Dell.com/idracmanuals.

Related links

- [Device Settings](#)
- [System BIOS](#)
- [Entering the iDRAC Settings utility](#)
- [Changing the thermal settings](#)

Entering the iDRAC Settings utility

- 1 Turn on or restart the managed system.
- 2 Press F2 during Power-on Self-test (POST).
- 3 On the **System Setup Main Menu** page, click **iDRAC Settings**.
The **iDRAC Settings** screen is displayed.

Related link

- [iDRAC Settings utility](#)

Changing the thermal settings

The iDRAC settings utility enables you to select and customize the thermal control settings for your system.

- 1 Click **iDRAC Settings > Thermal**.
- 2 Under **SYSTEM THERMAL PROFILE > Thermal Profile**, select one of the following options:
 - Default Thermal Profile Settings
 - Maximum Performance (Performance Optimized)
 - Minimum Power (Performance per Watt Optimized)
- 3 Under **USER COOLING OPTIONS**, set the **Fan Speed Offset**, **Minimum Fan Speed**, and **Custom Minimum Fan Speed**.

4 Click **Back** > **Finish** > **Yes**.

Related link

[iDRAC Settings utility](#)

Device Settings

Device Settings enables you to configure device parameters.

Related link

[System BIOS](#)

Dell Lifecycle Controller

Dell Lifecycle Controller (LC) provides advanced embedded systems management capabilities including system deployment, configuration, update, maintenance, and diagnosis. LC is delivered as part of the iDRAC out-of-band solution and Dell system embedded Unified Extensible Firmware Interface (UEFI) applications.

Related link

[Embedded system management](#)

Embedded system management

The Dell Lifecycle Controller provides advanced embedded systems management throughout the system's lifecycle. The Dell Lifecycle Controller can be started during the boot sequence and can function independently of the operating system.

NOTE: Certain platform configurations may not support the full set of features provided by the Dell Lifecycle Controller.

For more information about setting up the Dell Lifecycle Controller, configuring hardware and firmware, and deploying the operating system, see the Dell Lifecycle Controller documentation at Dell.com/idracmanuals.

Related link

[Dell Lifecycle Controller](#)

Boot Manager

The **Boot Manager** screen enables you to select boot options and diagnostic utilities.

Related links

[Boot Manager main menu](#)

[System BIOS](#)

[Viewing Boot Manager](#)

Viewing Boot Manager

To enter **Boot Manager**:

- 1 Turn on, or restart your system.
- 2 Press F11 when you see the following message:

```
F11 = Boot Manager
```

If your operating system begins to load before you press F11, allow the system to complete the booting, and then restart your system and try again.

Related links

- [Boot Manager](#)
- [Boot Manager main menu](#)

Boot Manager main menu

Menu item	Description
Continue Normal Boot	The system attempts to boot to devices starting with the first item in the boot order. If the boot attempt fails, the system continues with the next item in the boot order until the boot is successful or no more boot options are found.
One-shot Boot Menu	Enables you to access boot menu, where you can select a one-time boot device to boot from.
Launch System Setup	Enables you to access System Setup.
Launch Lifecycle Controller	Exits the Boot Manager and invokes the Dell Lifecycle Controller program.
System Utilities	Enables you to launch System Utilities menu such as System Diagnostics and UEFI shell.

Related links

- [Boot Manager](#)
- [Viewing Boot Manager](#)

One-shot BIOS boot menu

One-shot BIOS boot menu enables you to select a one-shot boot device to boot from the following options:

- Launch Diagnostics
- BIOS Update File Explorer
- Reboot System

Related link

- [Boot Manager](#)

System Utilities

System Utilities contains the following utilities that can be launched:

- Launch Diagnostics
- BIOS Update File Explorer
- Reboot System

Related link

- [Boot Manager](#)

PXE boot

The Preboot Execution Environment (PXE) is an industry standard client or interface that allows networked computers that are not yet loaded with an operating system to be configured and booted remotely by an administrator.

Installing and removing server module components

This section provides information about installing and removing the server module components. For information about installing and removing the enclosure components, see the enclosure Owner's Manual at [Dell.com/poweredgemanuals](https://www.dell.com/poweredge/manuals).

Topics:

- Safety instructions
- Recommended tools
- Installing and removing a server module
- System cover
- Inside the server module
- System memory
- Cooling shroud
- Processor blank and DIMM blank
- PCIe mezzanine cards
- Internal dual SD module (optional)
- rSPI card (optional)
- SD vFlash card
- Network Daughter Card
- Processors
- Hard drives or SSDs
- Hard drive or SSD backplane
- Storage controller card
- System board
- NVRAM backup battery

Safety instructions

⚠ CAUTION: Many repairs may only be done by a certified service technician. You should only perform troubleshooting and simple repairs as authorized in your product documentation, or as directed by the online or telephone service and support team. Damage due to servicing that is not authorized by Dell is not covered by your warranty. Read and follow the safety instructions that are shipped with your product.

ⓘ NOTE: Dell recommends that you always use an antistatic mat and antistatic wrist strap while working on components inside the system.

ⓘ NOTE: To ensure proper operation and cooling, all bays in the system must be populated always with either a system component or with a blank.

Before working inside your system

Prerequisite

Follow the safety guidelines listed in safety instructions section.

Steps

- 1 Turn off the server module by using the Chassis Management Controller (CMC).
- 2 Remove the server module from the enclosure.
- 3 Install the I/O connector cover.
- 4 Remove the system cover.

Related links

- [Safety instructions](#)
- [Removing the system cover](#)

After working inside your system

Prerequisite

Follow the safety guidelines listed in safety instructions section.

Steps

- 1 Install the system cover.
- 2 Install the server module in the enclosure.
- 3 Turn on the server module.

Related links

- [Safety instructions](#)
- [Installing the system cover](#)

Recommended tools

You may need the following items to perform the procedures in this section:

- Phillips #1 and #2 screwdrivers
- T8 and T10 Torx drivers
- Wrist grounding strap
- Hex nut driver-5 mm

Installing and removing a server module

NOTE: Server modules that are specifically configured for the PowerEdge VRTX enclosure, can be identified by a label marked **PCIe on the server module**.

NOTE: Ensure that you have downloaded the latest BIOS on the server module(s) from Dell.com/support/home.

Removing a server module

Prerequisites

CAUTION: Many repairs may only be done by a certified service technician. You should only perform troubleshooting and simple repairs as authorized in your product documentation, or as directed by the online or telephone service and support team. **Damage due to servicing that is not authorized by Dell is not covered by your warranty. Read and follow the safety instructions that came with the product.**

- 1 Follow the safety guidelines listed in safety instructions section.
- 2 If installed, remove the front bezel from the PowerEdge VRTX enclosure.
- 3 Turn off the server module using the operating system commands or the CMC, and ensure that the server module is powered off.

When a server module is powered off, its front panel power indicator is off.

Steps

- 1 Press the release button on the server module handle.

CAUTION: If you are permanently removing the server module, install a server module blank(s). Operating the system for extended periods of time without a server module blank installed can cause the enclosure to overheat.

- 2 Pull the server module handle to unlock the server module from the enclosure.

CAUTION: To prevent damage to the I/O connectors, do not touch connectors or the connector pins.

CAUTION: To protect the I/O connector pins, install the I/O connector covers every time a server module is removed from the enclosure.

- 3 Slide the server module out of the enclosure.

- 4 Install the I/O connector cover over the I/O connector.

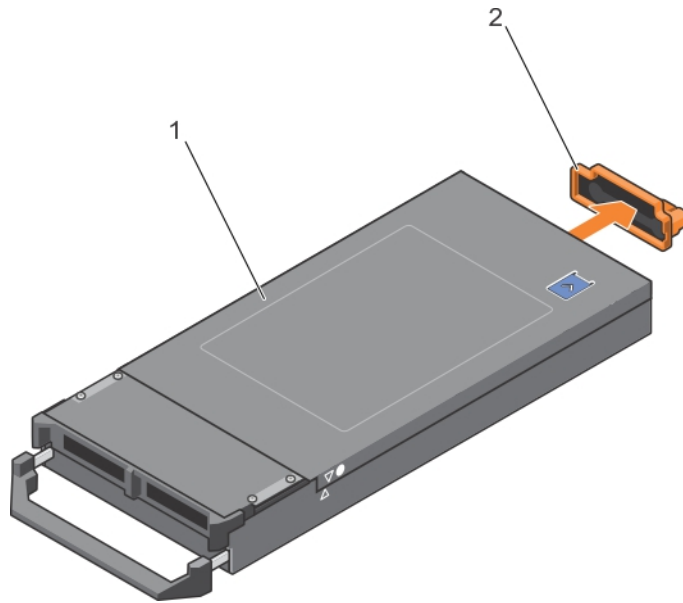

Figure 7. Removing the I/O connector cover

1 server module cover

2 I/O connector cover

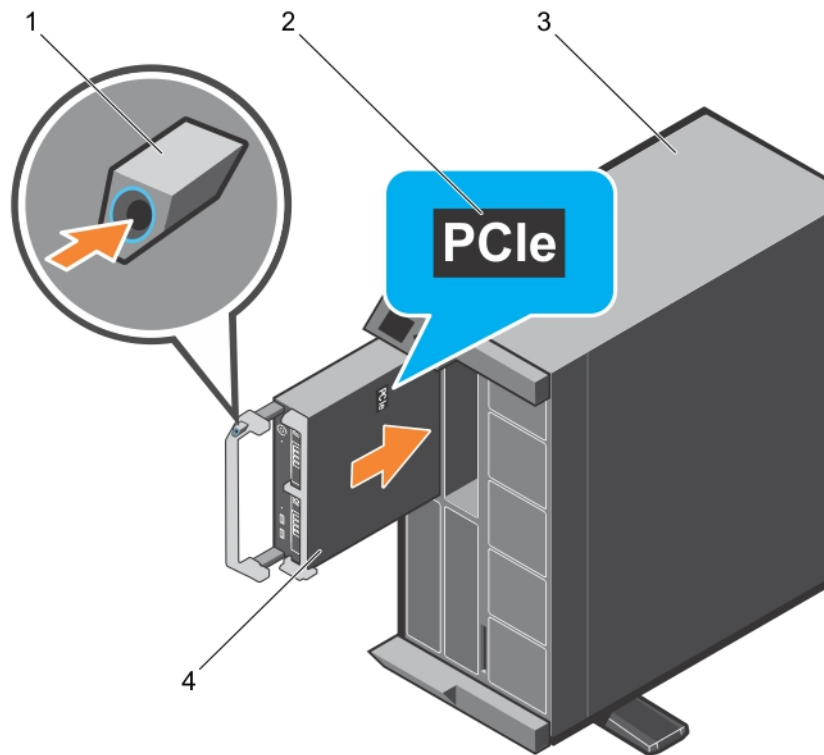

Figure 8. Removing a server module

1 release button

2 PCIe label on server module

3 VRTX enclosure

4 server module

NOTE: This label indicates that the server module is configured specifically for the VRTX enclosure.

Related links

[Safety instructions](#)

[Installing a server module](#)

Installing a server module

Prerequisites

Follow the safety guidelines listed in safety instructions section.

CAUTION: Many repairs may only be done by a certified service technician. You should only perform troubleshooting and simple repairs as authorized in your product documentation, or as directed by the online or telephone service and support team. Damage due to servicing that is not authorized by Dell is not covered by your warranty. Read and follow the safety instructions that came with the product.

CAUTION: To prevent damage to the I/O connectors, do not touch connectors or the connector pins.

NOTE: Before installing the server modules, place the chassis in the location that you want.

NOTE: Install the server module partitions to install half-height server module(s). For more information, see the *Dell PowerEdge VRTX Enclosure Owner's Manual* at Dell.com/poweredge/manuals.

Steps

- 1 If you are installing a new server module, remove the plastic cover from the I/O connector(s) and save for future use.
- 2 Orient the server module so that the module handle is on the left side of the server module.

⚠ CAUTION: While installing the server modules, ensure that they are properly aligned with the slots, to prevent damage to the server module connectors.

- 3 Align the server module with the server module slot and guide rails on the enclosure.
- 4 Slide the server module into the enclosure until the module release handle engages and the server module is locked in place.

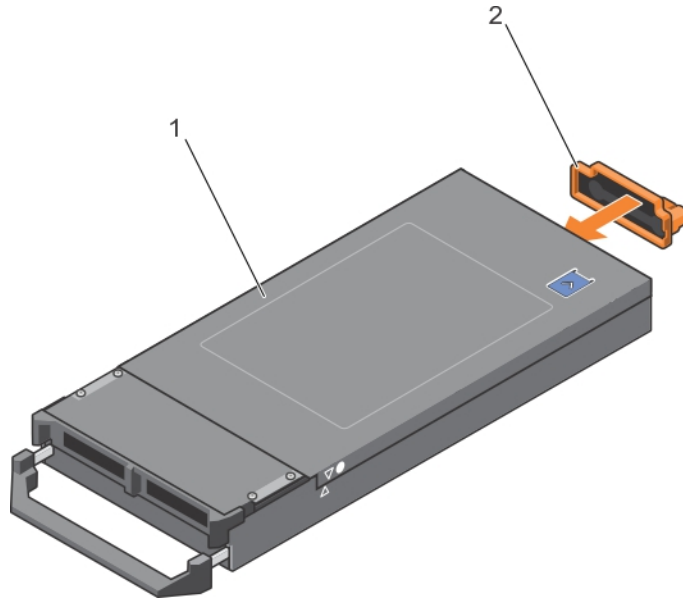

Figure 9. Installing the I/O connector cover

1 server module cover

2 I/O connector cover

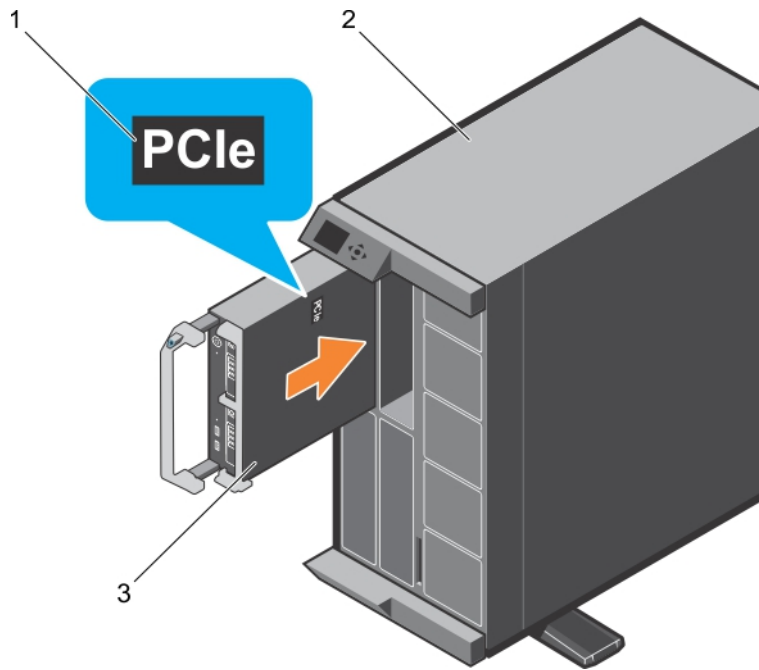

Figure 10. Installing a server module

- 1 PCIe label on server module
- 2 VRTX enclosure

NOTE: This label indicates that the server module is configured specifically for the VRTX enclosure.

- 3 server module

Next steps

- 1 Turn on the server module.
- 2 If applicable, install the front bezel of the PowerEdge VRTX enclosure.

Related links

- [Safety instructions](#)
- [Removing a server module](#)

System cover

The system cover protects the innards of the server, while also help maintaining proper flow of air inside the server. The removal of the system cover also actuate the intrusion switch and this aids in maintaining system security.

Removing the system cover

Prerequisites

- 1 Follow the safety guidelines listed in safety instructions section.
- 2 Turn off the server module by using CMC.
- 3 Remove the server module from the enclosure.
- 4 Install the I/O connector cover.

Steps

- 1 Press the release button and slide the cover toward the back of the server module.
- 2 Lift the cover away from the server module.

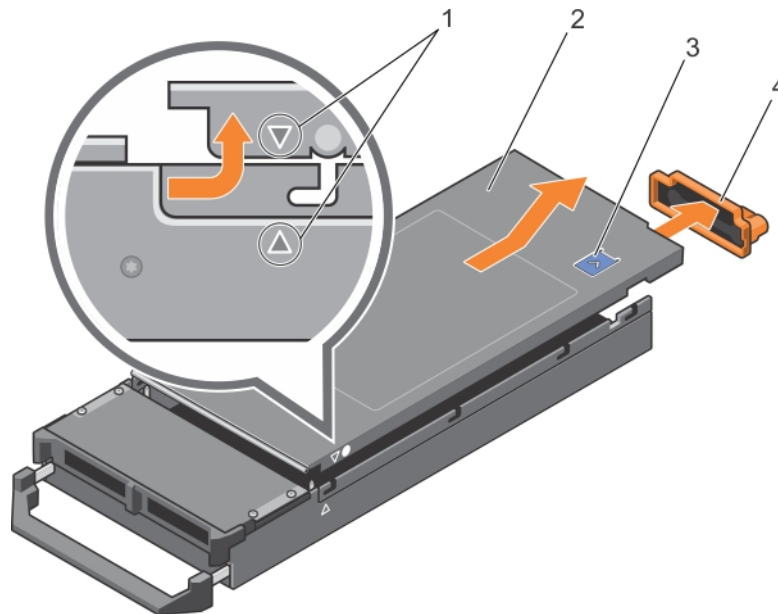

Figure 11. Removing the system cover

- | | | | |
|---|--|---|---------------------|
| 1 | alignment guides on the system cover and the chassis | 2 | system cover |
| 3 | release button | 4 | I/O connector cover |

Related links

- [Safety instructions](#)
- [Installing the system cover](#)

Installing the system cover

Prerequisites

- ⚠ CAUTION:** Many repairs may only be done by a certified service technician. You should only perform troubleshooting and simple repairs as authorized in your product documentation, or as directed by the online or telephone service and support team. Damage due to servicing that is not authorized by Dell is not covered by your warranty. Read and follow the safety instructions that came with the product.

- 1 Follow the safety guidelines listed in safety instructions section.
- 2 Ensure that no tools or parts are left inside the server module.

Steps

- 1 Align the alignment guide on the system cover with the alignment guide on the chassis.
- 2 Lower the cover onto the chassis.
- 3 Slide the cover until it clicks into position.
A properly seated cover is flush with the surface of the chassis.

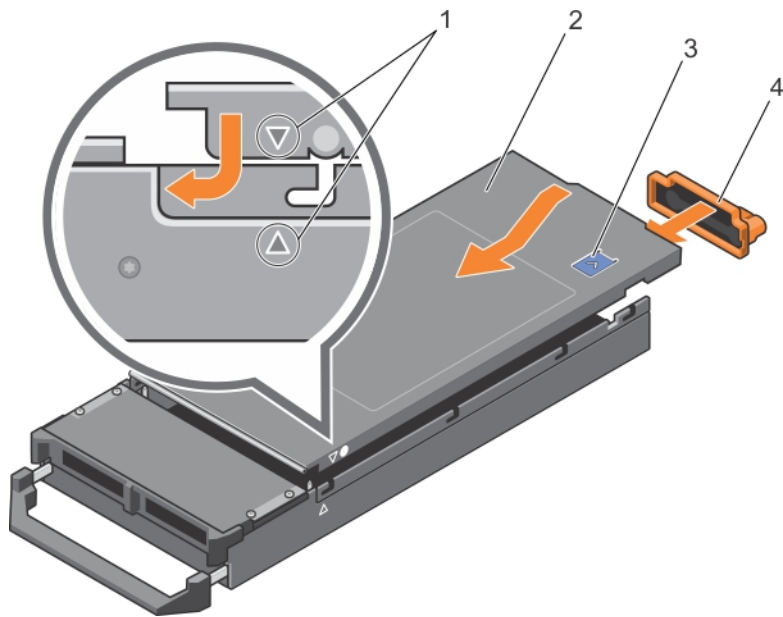

Figure 12. Installing the system cover

- | | | | |
|---|--|---|---------------------|
| 1 | alignment guides on the system cover and the chassis | 2 | system cover |
| 3 | release button | 4 | I/O connector cover |

Next step

Follow the procedure listed in the After working inside your system section.

Related links

- [Safety instructions](#)
- [Removing the system cover](#)

Inside the server module

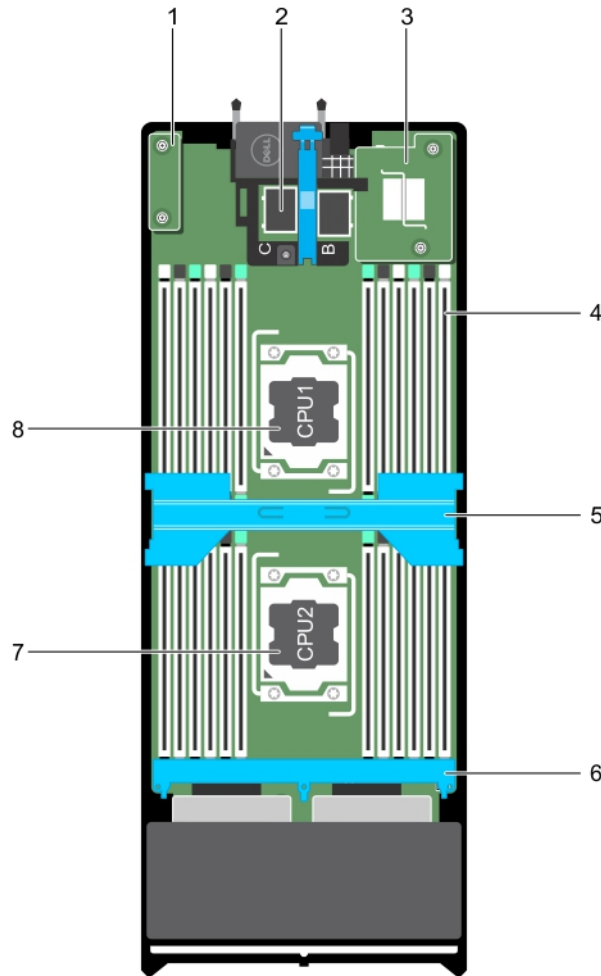

Figure 13. Inside the server module

- | | | | |
|---|----------------|---|-----------------------------------|
| 1 | rSPI card | 2 | PCIe mezzanine card connector (2) |
| 3 | NDC | 4 | Memory module (24) |
| 5 | Cooling shroud | 6 | Hard drive or SSD backplane |
| 7 | Processor 2 | 8 | Processor 1 |

System memory

Your system supports DDR4 registered DIMMs (RDIMMs) and load reduced DIMMs (LRDIMMs). It supports DDR4 voltage specifications.

NOTE: MT/s indicates DIMM speed in MegaTransfers per second.

Memory bus operating frequency can be 2400 MT/s, 2133 MT/s, or 1866 MT/s depending on:

- Number of DIMMs populated per channel
- System profile selected (for example, Performance Optimized, Custom, or Dense Configuration Optimized)
- Maximum supported DIMM frequency of the processors

The system contains 24 memory sockets split into two sets of 12 sockets, one set per processor. Each 12-socket set is organized into four channels. In each channel, the release levers of the first socket are marked white, the second socket black, and the third socket green.

NOTE: DIMMs in sockets A1 to A12 are assigned to processor 1 and DIMMs in sockets B1 to B12 are assigned to processor 2.

The following table shows the memory populations and operating frequencies for the supported configurations.

Table 21. Memory population — operating frequency for supported configuration

DIMM Type	DIMMs Populated Per Channel	Voltage	Operating Frequency (in MT/s)	Maximum DIMM Rank Per Channel
RDIMM	1	1.2 V	2400, 2133, 1866	Single rank or dual rank
	2		2400, 2133, 1866	
	3		1866	
LRDIMM	1	1.2 V	2400, 2133, 1866	Quad rank
	2		2400, 2133, 1866	
	3		2133, 1866	

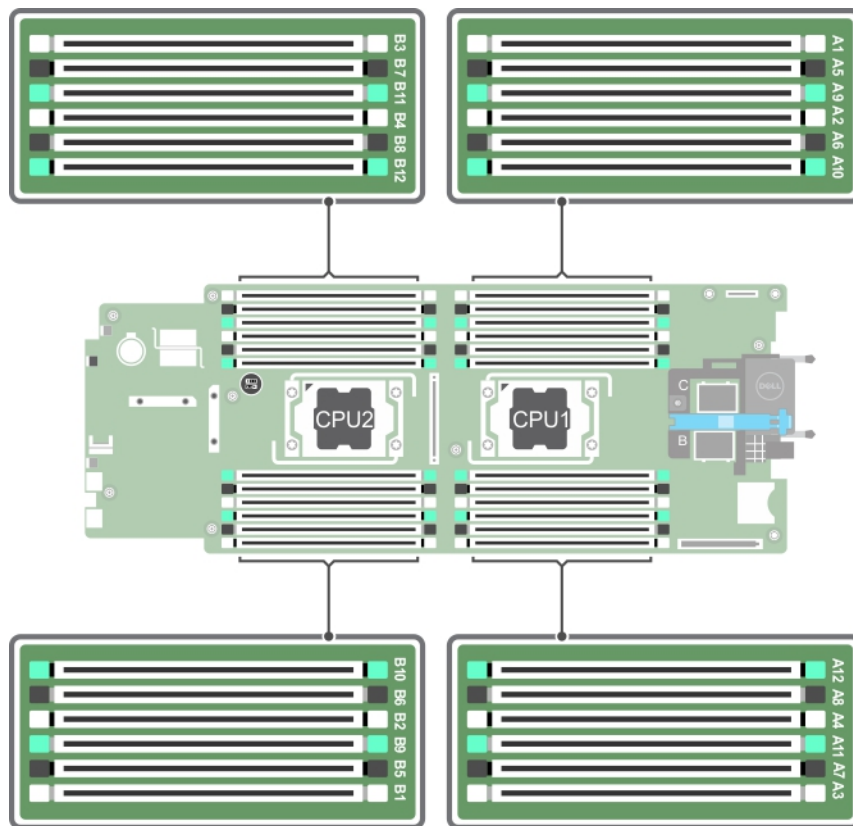

Figure 14. Memory socket locations

Memory channels are organized as follows:

Processor 1 channel 0: memory sockets A1, A5, and A9

channel 1: memory sockets A2, A6, and A10

channel 2: memory sockets A3, A7, and A11

channel 3: memory sockets A4, A8, and A12

Processor 2

channel 0: memory sockets B1, B5, and B9

channel 1: memory sockets B2, B6, and B10

channel 2: memory sockets B3, B7, and B11

channel 3: memory sockets B4, B8, and B12

General memory module installation guidelines

Your system supports Flexible Memory Configuration, enabling the system to be configured and run in any valid chipset architectural configuration. The following are the recommended guidelines for best performance:

- LRDIMMs, and RDIMMs must not be mixed.
- x4 and x8 DRAM based DIMMs can be mixed. For more information, see the Mode-specific guidelines section.
- A maximum of three single- or dual-rank RDIMMs can be populated in a channel.
- Populate DIMM sockets only if a processor is installed. For single-processor systems, sockets A1 to A12 are available. For dual-processor systems, sockets A1 to A12 and sockets B1 to B12 are available.
- Populate all sockets with white release tabs first, black, and then green.
- Populate the sockets by highest capacity DIMM in the following order - first in sockets with white release levers and then black. For example, if you want to mix 16 GB and 8 GB DIMMs, populate 16 GB DIMMs in the sockets with white release tabs and 8 GB DIMMs in the sockets with black release tabs.
- In a dual-processor configuration, the memory configuration for each processor must be identical. For example, if you populate socket A1 for processor 1, then populate socket B1 for processor 2, and so on.
- Memory modules of different sizes can be mixed provided that other memory population rules are followed (for example, 4 GB and 8 GB memory modules can be mixed).
- Depending on mode-specific guidelines, populate four DIMMs per processor (one DIMM per channel) at a time to maximize performance. For more information, see the Mode-specific guidelines section.

Table 22. Heat sink — processor configurations

Processor Configuration	Processor Type (in Watts)	Heat Sink Width	Number of DIMMs	
			Maximum System Capacity	Reliability, Availability, and Serviceability (RAS) Features
Single processor	105 W, 120 W or 135 W	68 mm	12	12
Single processor	135 W (four cores, six cores, or eight cores), 145 W, or 105 W (for acoustic configuration)	86 mm	10 (Three DIMMs in channel 0 and channel 2 and two DIMMs in channel 1 and channel 3)	8 (Two DIMMs per channel)
NOTE: When using an 86 mm wide heat sink for a single processor, the memory module sockets A10 and A12 are not available for population.				
Dual processor	105 W, 120 W or 135 W	68 mm	24	24
Dual processor	135 W (four cores, six cores, or eight cores), 145 W, or 105 W (for acoustic configuration)	86 mm	20 (Three DIMMs in channel 0 and channel 2 and two DIMMs in channel 1 and channel 3)	16 (Two DIMMs per channel)

Related link

[Mode-specific guidelines](#)

Mode-specific guidelines

Four memory channels are allocated to each processor. The allowable configurations depend on the memory mode selected.

Advanced Error Correction Code (lockstep)

Advanced Error Correction Code (ECC) mode extends SDDC from x4 DRAM based DIMMs to both x4 and x8 DRAMs. This protects against single DRAM chip failures during normal operation.

The installation guidelines for memory modules are as follows:

- Memory modules must be identical in size, speed, and technology.
- DIMMs installed in memory sockets with white release levers must be identical and the same rule applies for sockets with black release levers. This ensures that identical DIMMs are installed in matched pair—for example, A1 with A2, A3 with A4, A5 with A6, and so on.

Memory optimized (independent channel) mode

This mode supports Single Device Data Correction (SDDC) only for memory modules that use x4 device width. It does not impose any specific slot population requirements.

Memory sparing

NOTE: To use memory sparing, this feature must be enabled in System Setup.

In this mode, one rank per channel is reserved as a spare. If persistent correctable errors are detected on a rank, the data from this rank is copied to the spare rank, and the failed rank is disabled.

With memory sparing enabled, the system memory available to the operating system is reduced by one rank per channel. For example, in a dual-processor configuration with sixteen 4 GB single-rank memory modules, the available system memory is: $3/4$ (ranks/channel) \times 16 (memory modules) \times 4 GB = 48 GB, and not 16 (memory modules) \times 4 GB = 64 GB.

NOTE: Memory sparing does not offer protection against a multi-bit uncorrectable error.

NOTE: Both Advanced ECC/Lockstep and Optimizer modes support memory sparing.

Memory mirroring

Memory mirroring offers the strongest memory module reliability mode compared to all other modes, providing improved uncorrectable multi-bit failure protection. In a mirrored configuration, the total available system memory is one half of the total installed physical memory. Half of the installed memory is used to mirror the active memory modules. In the event of an uncorrectable error, the system switches over to the mirrored copy. This ensures SDDC and multi-bit protection.

The installation guidelines for memory modules are as follows:

- Memory modules must be identical in size, speed, and technology.
- Memory modules installed in memory module sockets with white release levers must be identical and the same rule applies for sockets with black and green release tabs. This ensures that identical memory modules are installed in matched pairs—for example, A1 with A2, A3 with A4, A5 with A6, and so on.

Table 23. Processor configuration

Processor	Configuration	Memory population rules	Memory population information
Single CPU	Memory population order	{1,2}, {3,4}	See Memory mirroring note

Sample memory configurations

The following tables show sample memory configurations that follow the appropriate memory guidelines stated in this section.

NOTE: 1R, 2R, and 4R in the following tables indicate single-, dual-, and quad-rank DIMMs respectively.

NOTE: When using an 86 mm wide heat sink for single processor, the memory module sockets A10 and A12 are not available for population.

Table 24. Memory configurations – single processor

System Capacity (in GB)	DIMM Size (in GB)	Number of DIMMs	Organization and Speed	DIMM Slot Population
16	4	4	1R x8, 2133 MT/s	A1, A2, A3, A4
			1R x8, 2400 MT/s	
			2R x8, 2400 MT/s	
24	4	6	1R x8, 2133 MT/s	A1, A2, A3, A4, A5, A6
48	8	6	2R x8, 2133 MT/s	A1, A2, A3, A4, A5, A6
96	16	6	2R x4, 2133 MT/s	A1, A2, A3, A4, A5, A6
128	16	8	2R x4, 2133 MT/s	A1, A2, A3, A4, A5, A6, A7, A8
256	32	8	4R x4, 2133 MT/s	A1, A2, A3, A4, A5, A6, A7, A8
768	64	12	4R x4, 2400 MT/s	A1, A2, A3, A4, A5, A6, A7, A8, A9, A10, A11, A12

NOTE: When using an 86 mm wide heat sink for single processor, the memory module sockets A10 and A12 are not available for population.

Table 25. Memory configurations – two processors

System Capacity (in GB)	DIMM Size (in GB)	Number of DIMMs	Organization and Speed	DIMM Slot Population
32	4	8	1R x8, 2133 MT/s	A1, A2, A3, A4, B1, B2, B3, B4
			1R x8, 2400 MT/s	
			2R x8, 2400 MT/s	
64	4	16	1R x8, 2133 MT/s	A1, A2, A3, A4, A5, A6, A7, A8, B1, B2, B3, B4, B5, B6, B7, B8
64	8	8	2R x8, 2133 MT/s	A1, A2, A3, A4, B1, B2, B3, B4

System Capacity (in GB)	DIMM Size (in GB)	Number of DIMMs	Organization and Speed	DIMM Slot Population
96	8	12	2R x8, 2133 MT/s	A1, A2, A3, A4, A5, A6, B1, B2, B3, B4, B5, B6
128	8	16	2R x8, 2133 MT/s	A1, A2, A3, A4, A5, A6, A7, A8, B1, B2, B3, B4, B5, B6, B7, B8
128	16	8	2R x4, 2133 MT/s	A1, A2, A3, A4, B1, B2, B3, B4
160	16 and 8	12	2R x4, 2133 MT/s	A1, A2, A3, A4, A5, A6, B1, B2, B3, B4, B5, B6
<div style="display: flex; align-items: center;"> <div style="margin-right: 10px;">  </div> <div> <p>NOTE: 16 GB DIMMs must be installed in the slots numbered A1, A2, A3, A4, B1, B2, B3, and B4 and 8 GB DIMMs must be installed in slots A5, A6, B5 and B6.</p> </div> </div>				
192	16	12	2R x4, 2133 MT/s	A1, A2, A3, A4, A5, A6, B1, B2, B3, B4, B5, B6
256	16	16	2R x4, 2133 MT/s	A1, A2, A3, A4, A5, A6, A7, A8, B1, B2, B3, B4, B5, B6, B7, B8
512	32	16	4R x4, 2133 MT/s	A1, A2, A3, A4, A5, A6, A7, A8, B1, B2, B3, B4, B5, B6, B7, B8
1536	64	24	4R x4, 2400 MT/s	A1, A2, A3, A4, A5, A6, A7, A8, A9, A10, A11, A12, B1, B2, B3, B4, B5, B6, B7, B8, B9, B10, B11, B12

Removing memory modules

Prerequisites

- ⚠ **WARNING:** The memory modules are hot to touch for some time after the system has been powered down. Allow time for the memory modules to cool before handling them. Handle the memory modules by the card edges and avoid touching the components or metallic contacts on the memory module.
- ⚠ **CAUTION:** Many repairs may only be done by a certified service technician. You should only perform troubleshooting and simple repairs as authorized in your product documentation, or as directed by the online or telephone service and support team. Damage due to servicing that is not authorized by Dell is not covered by your warranty. Read and follow the safety instructions that are shipped with your product.
- ⚠ **CAUTION:** To ensure proper system cooling, memory module blanks must be installed in any memory socket that is not occupied. Remove memory module blanks only if you intend to install memory modules in those sockets.

- 1 Follow the safety guidelines listed in safety instructions section.
- 2 Follow the procedure listed in the Before working inside your system section.
- 3 Remove the cooling shroud.

Steps

- 1 Locate the appropriate memory module socket(s).
- 2 To release the memory module from the socket, simultaneously press the ejectors on both ends of the memory module socket.

CAUTION: Handle each memory module only by the card edges, ensuring not to touch the middle of the memory module or metallic contacts.

- 3 Remove the memory module from the socket.

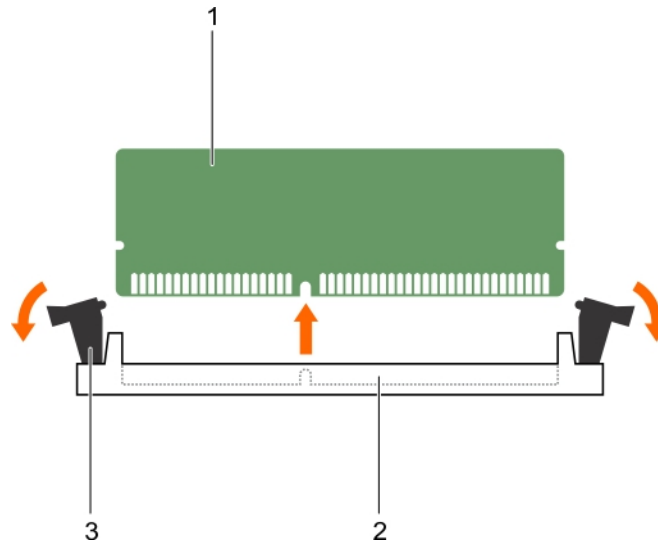

Figure 15. Removing the memory module

- | | | | |
|---|---------------------------|---|----------------------|
| 1 | memory module | 2 | memory module socket |
| 3 | memory module ejector (2) | | |

Next steps

- 1 If you are removing the memory module permanently, install a memory module blank. If you are installing a new memory module, see the Installing the Memory Module section.
- 2 Follow the procedure listed in the After working inside your system section.

Related links

[Safety instructions](#)
[Installing memory modules](#)
[Before working inside your system](#)
[After working inside your system](#)

Installing memory modules

Prerequisites

CAUTION: Many repairs may only be done by a certified service technician. You should only perform troubleshooting and simple repairs as authorized in your product documentation, or as directed by the online or telephone service and support team. Damage due to servicing that is not authorized by Dell is not covered by your warranty. Read and follow the safety instructions that are shipped with your product.

NOTE: You must remove a memory module to upgrade a memory module or replace a faulty memory module.

- 1 Follow the safety guidelines listed in safety instructions section.
- 2 Follow the procedure listed in the Before working inside your system section.
- 3 If installed, remove the memory module or the memory module blank.

⚠ WARNING: The memory modules are hot to touch for some time after the system has been powered down. Allow time for the memory modules to cool before handling them. Handle the memory modules by the card edges and avoid touching the components or metallic contacts on the memory module.

Steps

- 1 Locate the appropriate memory module socket.
- 2 Press the ejectors on the memory module socket outward to allow the memory module to be inserted into the socket.
 - ⚠ **CAUTION:** Handle each memory module only on either card edge, making sure not to touch the middle of the memory module.
- 3 Align the edge connector on the memory module with the alignment key on the memory module socket, and insert the memory module in the socket.
 - ⓘ **NOTE:** The memory module socket has an alignment key that allows you to install the memory module in the socket in only one orientation.
 - ⚠ **CAUTION:** To prevent damage to the memory module socket during installation, apply pressure at both ends of the memory module evenly. Do not apply pressure to the center of the memory module.
- 4 Press down on the memory module with your thumbs to lock the memory module into the socket.
 - ⓘ **NOTE:** When the memory module is properly seated in the socket, the ejectors on the memory module socket align with the ejectors on the other sockets that have memory modules installed.
- 5 Repeat step 4 through step 7 of this procedure to install the remaining memory modules.

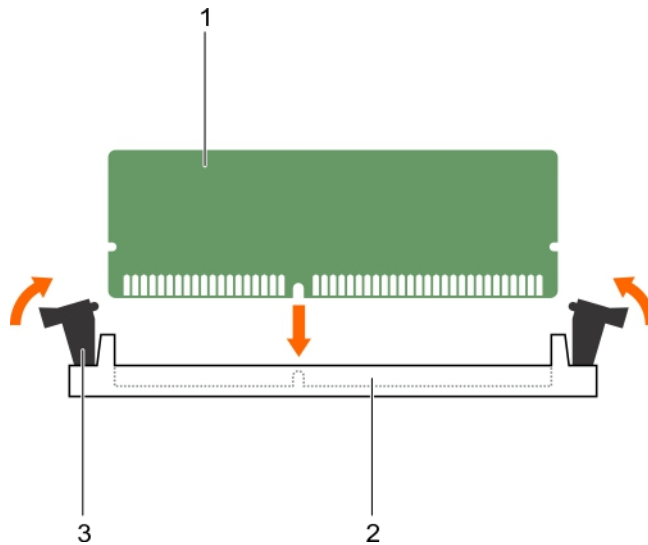

Figure 16. Installing the memory module

- | | | | |
|---|---------------------------|---|----------------------|
| 1 | memory module | 2 | memory module socket |
| 3 | memory module ejector (2) | | |

Next steps

- 1 Follow the procedure listed in the After working inside your system section.
- 2 (Optional) Press F2 to enter the System Setup, and check the **System Memory** setting.

The system should have already changed the value to reflect the newly installed memory.

ⓘ **NOTE:** If the value is incorrect, one or more of the memory modules may not be installed properly. Check to ensure that the memory modules are firmly seated in their sockets.

- 3 Run the system memory test in the system diagnostics.

Related links

- [Safety instructions](#)
- [Before working inside your system](#)
- [After working inside your system](#)

Cooling shroud

The cooling shroud has aerodynamically placed openings that directs the airflow across the entire system. The airflow passes through all the critical parts of the system, where the vacuum that pulls air across the entire surface area of the processor and heat sink allowing increased cooling.

Removing the cooling shroud

Prerequisites

- CAUTION:** Many repairs may only be done by a certified service technician. You should only perform troubleshooting and simple repairs as authorized in your product documentation, or as directed by the online or telephone service and support team. Damage due to servicing that is not authorized by Dell is not covered by your warranty. Read and follow the safety instructions that came with the product.
- CAUTION:** Never operate your system with the cooling shroud removed. The system may get overheated quickly, resulting in shutdown and loss of data.

- 1 Follow the safety guidelines listed in safety instructions section.
- 2 Follow the procedure listed in the Before working inside your system section.

Step

Hold the cooling shroud at both ends and lift it up and away from the system.

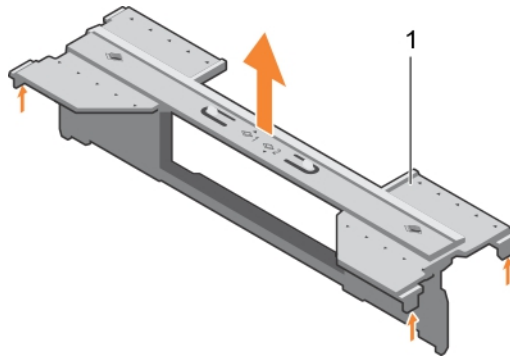

Figure 17. Removing the cooling shroud

- 1 cooling shroud

Next steps

- 1 Install the cooling shroud.
- 2 Follow the procedure listed in the After working inside your system section.

Related links

- [Safety instructions](#)
- [Installing the cooling shroud](#)
- [Before working inside your system](#)
- [After working inside your system](#)

Installing the cooling shroud

Prerequisites

CAUTION: Many repairs may only be done by a certified service technician. You should only perform troubleshooting and simple repairs as authorized in your product documentation, or as directed by the online or telephone service and support team. Damage due to servicing that is not authorized by Dell is not covered by your warranty. Read and follow the safety instructions that came with the product.

NOTE: You must remove the cooling shroud to service other components inside the system.

- 1 Follow the safety guidelines listed in safety instructions section.
- 2 Follow the procedure listed in the Before working inside your system section.
- 3 Ensure that the cooling shroud is removed.

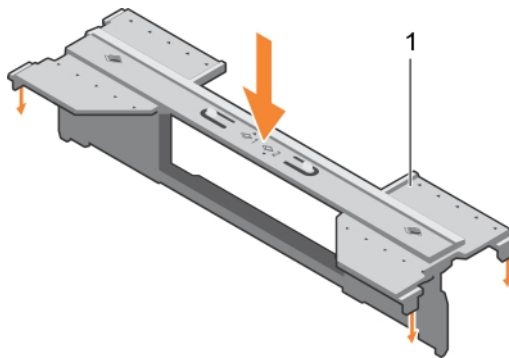

Figure 18. Installing the cooling shroud

1 cooling shroud

Step

Lower the cooling shroud into the chassis until it is firmly seated.

Next step

Follow the procedure listed in the After working inside your system section.

Related links

- [Safety instructions](#)
- [Removing the cooling shroud](#)
- [Before working inside your system](#)
- [After working inside your system](#)

Processor blank and DIMM blank

The processor blank and DIMM blank supplied with your system aids in directing airflow over the unused processor sockets and DIMM slots.

CAUTION: If you are permanently removing a processor, you must install a socket protective cap and a processor blank and DIMM blank in the vacant socket to ensure proper system cooling. The processor blank and DIMM blank covers the vacant sockets for the DIMMs and the processor.

Removing a processor or DIMM blank

Prerequisites

CAUTION: Many repairs may only be done by a certified service technician. You should only perform troubleshooting and simple repairs as authorized in your product documentation, or as directed by the online or telephone service and support team. Damage due to servicing that is not authorized by Dell is not covered by your warranty. Read and follow the safety instructions that came with the product.

- 1 Follow the safety guidelines listed in safety instructions section.
- 2 Follow the procedure listed in the Before working inside your system section.

Step

Hold the processor/DIMM blank by its edges and lift it away from the system.

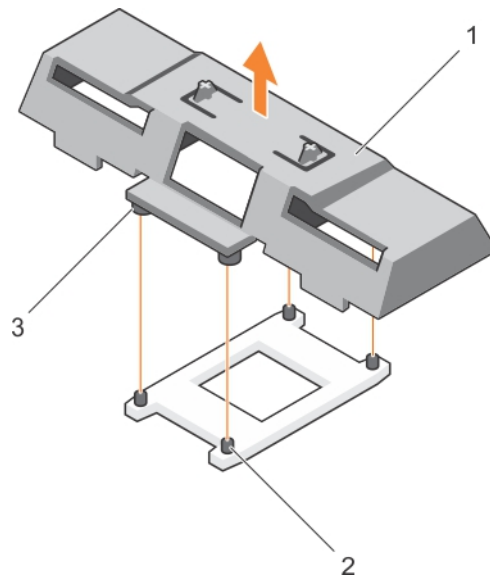

Figure 19. Removing a processor or DIMM blank

- | | | | |
|---|-------------------------|---|--------------------------------|
| 1 | processor or DIMM blank | 2 | heat sink retention socket (4) |
| 3 | standoff (4) | | |

Next steps

- 1 Install the processor and the heat sink.
- 2 Ensure that you install the processor or DIMM blank when you have removed a processor permanently.
- 3 Follow the procedure listed in the After working inside your system section.

Related links

- [Safety instructions](#)
- [Installing a processor](#)
- [Installing a processor or DIMM blank](#)
- [Before working inside your system](#)
- [After working inside your system](#)

Installing a processor or DIMM blank

Prerequisites

CAUTION: Many repairs may only be done by a certified service technician. You should only perform troubleshooting and simple repairs as authorized in your product documentation, or as directed by the online or telephone service and support team. Damage due to servicing that is not authorized by Dell is not covered by your warranty. Read and follow the safety instructions that came with the product.

NOTE: You must remove processor or DIMM blank when installing two processors or to service other components inside the system.

- 1 Follow the safety guidelines listed in safety instructions section.
- 2 Follow the procedure listed in the Before working inside your system section.
- 3 Your system does not have processor or heat sink installed.

Steps

- 1 Align the standoffs on the processor or DIMM blank with the heat sink retention sockets on the processor socket.
- 2 Lower the processor or DIMM blank onto the system until the standoffs on the processor or DIMM blank engages with the heat sink retention sockets.

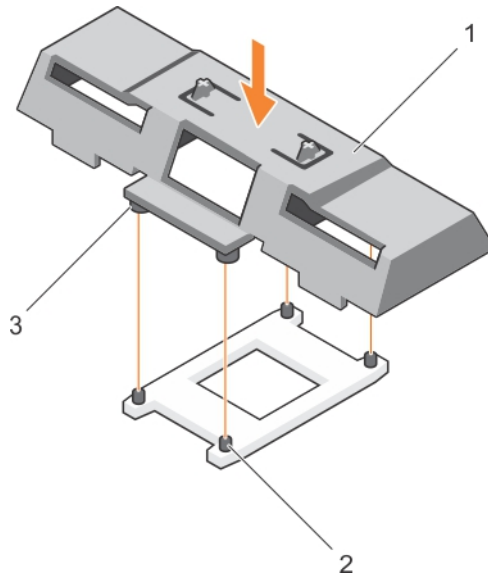

Figure 20. Installing a processor/DIMM blank

- | | | | |
|---|-------------------------|---|--------------------------------|
| 1 | processor or DIMM blank | 2 | heat sink retention socket (4) |
| 3 | standoff (4) | | |

Next step

Follow the procedure listed in the After working inside your system section.

Related links

- [Safety instructions](#)
- [Installing a processor](#)
- [Removing a processor or DIMM blank](#)
- [Before working inside your system](#)
- [After working inside your system](#)

PCIe mezzanine cards

The server module supports two x8 PCIe Gen 2 mezzanine cards. No other mezzanine cards, such as Ethernet, Fibre Channel, or InfiniBand are supported on server modules configured for the PowerEdge VRTX enclosure.

The PCIe mezzanine cards provide an interface between server modules and the PCIe switches in the enclosure.

NOTE: You cannot operate the system with a single PCIe mezzanine card. Two PCIe mezzanine cards are required per server module to support the PCIe expansion cards and PERC card-based shared storage on the enclosure.

NOTE: For proper operation, make sure that both PCIe mezzanine cards are set to Enabled in the System Setup.

Removing the PCIe mezzanine card

Prerequisites

CAUTION: Many repairs may only be done by a certified service technician. You should only perform troubleshooting and simple repairs as authorized in your product documentation, or as directed by the online or telephone service and support team. Damage due to servicing that is not authorized by Dell is not covered by your warranty. Read and follow the safety instructions that came with the product.

- 1 Follow the safety guidelines listed in safety instructions section.
- 2 Follow the procedure listed in the Before working inside your system section.

Steps

- 1 Open the retention latch by pressing the ridged area on the retention latch, and lifting the latch up.

CAUTION: To prevent damage to the PCIe mezzanine card, you must hold the card only by its edges.

- 2 Lift the PCIe mezzanine card up and away from the system.
- 3 Close the retention latch.

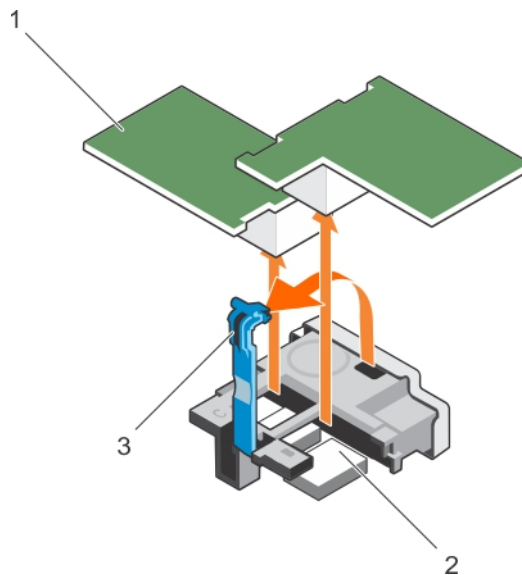

Figure 21. Removing the PCIe mezzanine card

- | | | | |
|---|------------------------------------|---|---------------|
| 1 | PCIe mezzanine card (2) | 2 | connector (2) |
| 3 | ridged area on the retention latch | | |

Next steps

- 1 Install the PCIe mezzanine card.
- 2 Follow the procedure listed in the After working inside your system section.

Related links

- [Safety instructions](#)
- [Installing the PCIe mezzanine card](#)
- [Before working inside your system](#)
- [After working inside your system](#)

Installing the PCIe mezzanine card

Prerequisites

⚠ CAUTION: Many repairs may only be done by a certified service technician. You should only perform troubleshooting and simple repairs as authorized in your product documentation, or as directed by the online or telephone service and support team. Damage due to servicing that is not authorized by Dell is not covered by your warranty. Read and follow the safety instructions that came with the product.

ⓘ NOTE: You must remove the PCIe mezzanine card to replace a faulty PCIe mezzanine card or service other components inside the system.

- 1 Follow the safety guidelines listed in safety instructions section.
- 2 Remove the PCIe mezzanine card.

Steps

- 1 Open the retention latch by pressing the ridged area on the retention latch with your thumb and lifting the end of the latch.
- 2 If present, remove the connector cover from the PCIe mezzanine card bay.

⚠ CAUTION: To prevent damage to the PCIe mezzanine card, you must hold the card only by its edges.

- 3 Rotate the card to align the connector on the bottom of the PCIe mezzanine card with the corresponding socket on the system board.
- 4 Lower the card into place until it is fully seated and the plastic clip on the outer edge of the card engages over the side of the server module chassis.
- 5 Close the retention latch to secure the PCIe mezzanine card.

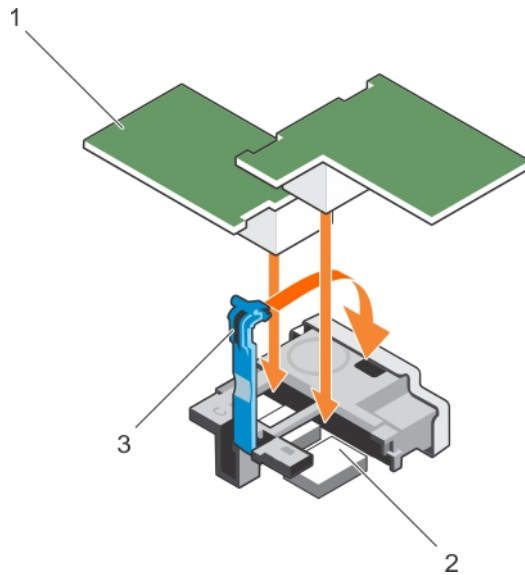

Figure 22. Installing the PCIe mezzanine card

- | | |
|--|---|
| <ol style="list-style-type: none"> 1 PCIe mezzanine card (2) 3 ridge area on the retention latch | <ol style="list-style-type: none"> 2 connector (2) |
|--|---|

Next step

Follow the procedure listed in the After working inside your system section.

Related links

- [Safety instructions](#)
- [Removing the PCIe mezzanine card](#)
- [Before working inside your system](#)
- [After working inside your system](#)

Internal dual SD module (optional)

The Internal Dual SD module (IDSDM) provides you with a redundant SD card solution. You can configure the IDSDM for storage or as the OS boot partition. In modular servers, you can choose either a redundant SD module mode or share one slot with the iDRAC module and the remaining slot can be used for storage or as the OS partition.

The Internal Dual SD Module (IDSDM) card provides two SD card slots and a USB interface dedicated for the embedded hypervisor. This card offers the following features:

- Dual card operation—maintains a mirrored configuration by using SD cards in both slots and provides redundancy.
- Single card operation—single card operation is supported, but without redundancy.

Replacing an SD card

Prerequisites

⚠ CAUTION: Many repairs may only be done by a certified service technician. You should only perform troubleshooting and simple repairs as authorized in your product documentation, or as directed by the online or telephone service and support team. Damage due to servicing that is not authorized by Dell is not covered by your warranty. Read and follow the safety instructions that are shipped with your product.

- 1 Follow the safety guidelines listed in safety instructions section.

- 2 Follow the procedure listed in the Before working inside your system section.
- 3 Enter the System Setup and ensure that the **Internal SD Card Port** is enabled.

⚠ CAUTION: When an SD card failure occurs, and the Internal SD Card Redundancy option in the Integrated Devices screen of the System Setup is set to Mirror Mode, there may be loss of data. To avoid data loss, follow step 4 through step 6 of the Troubleshooting an internal SD card section.

① NOTE: The SD card in the lower card slot is the primary card (SD1) and the SD card in the upper card slot is the secondary card (SD2).

① NOTE: When an SD card failure occurs, the Internal SD Card Redundancy option in the System Setup is set to Disabled and the internal dual SD module controller notifies the system. On the next reboot, the system displays a message indicating the failure.

① NOTE: If the Internal SD Card Redundancy option is set to Disabled, replace the failed SD card with a new SD card.

Steps

- 1 Locate the SD card slot on the internal dual SD module (IDSDM) card.
- 2 Press inward on the card to release it from the slot, and remove the card.

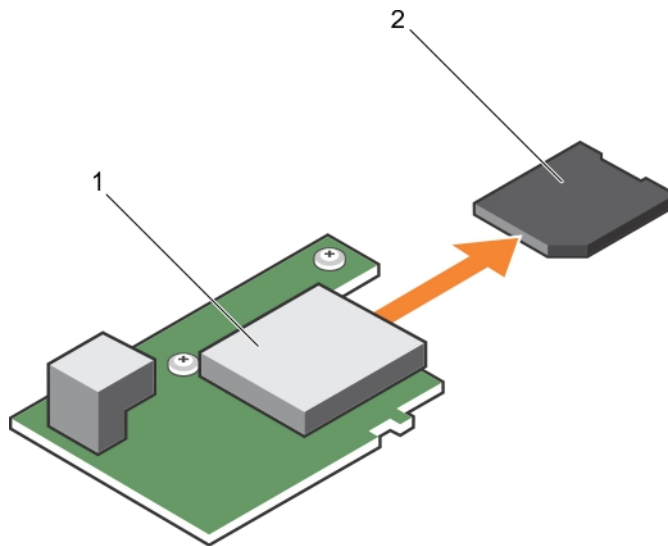

Figure 23. Replacing an SD card

1 IDSDM card

2 SD card

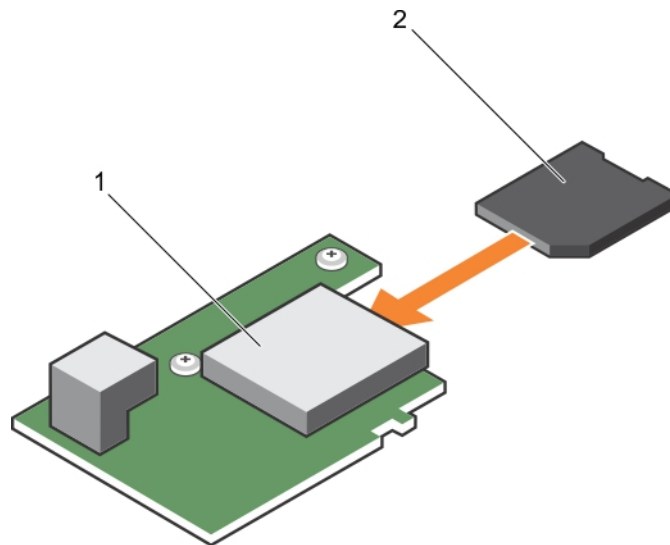

Figure 24. Installing an SD card

1 IDSDM card

2 SD card

Next steps

- 1 Follow the procedure listed in the After working inside your system section.
- 2 Enter the System Setup and ensure that the **Internal SD Card Port** and **Internal SD Card Redundancy** mode is enabled.
- 3 Check if the new SD card is functioning properly. If the problem persists, see the Getting help section.

Related links

- [Getting help](#)
- [Safety instructions](#)
- [Before working inside your system](#)
- [Troubleshooting an Internal SD Card](#)
- [After working inside your system](#)

Internal USB key

The server module provides an internal USB connector for a USB flash memory key. The USB memory key can be used as a boot device, security key, or mass storage device. To use the internal USB connector, the **Internal USB Port** option must be enabled in the **Integrated Devices** screen of the System Setup.

To boot from the USB memory key, you must configure the USB memory key with a boot image, and then specify the USB memory key in the boot sequence in the System Setup. For information on creating a bootable file on the USB memory key, see the user documentation that shipped with the USB memory key.

Replacing the internal USB key

Prerequisites

- CAUTION:** Many repairs may only be done by a certified service technician. You should only perform troubleshooting and simple repairs as authorized in your product documentation, or as directed by the online or telephone service and support team. Damage due to servicing that is not authorized by Dell is not covered by your warranty. Read and follow the safety instructions that came with the product.

CAUTION: To avoid interference with other components in the server module, the maximum permissible dimensions of the USB key are 15.9 mm wide x 57.15 mm long x 7.9 mm high.

- 1 Follow the safety guidelines listed in safety instructions section.
- 2 Follow the procedure listed in the Before working inside your system section.

Steps

- 1 Locate the USB connector/USB key.
- 2 If installed, remove the USB key.
- 3 Insert the new USB memory key into the USB connector.

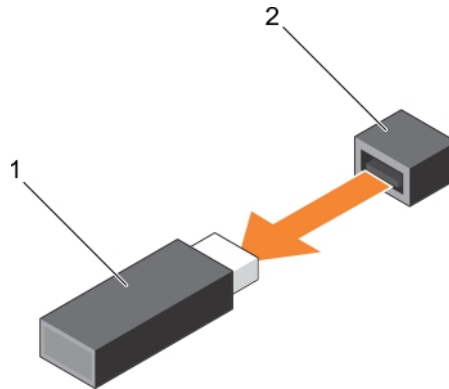

Figure 25. Replacing the USB memory key

1 USB memory key

2 USB memory key connector

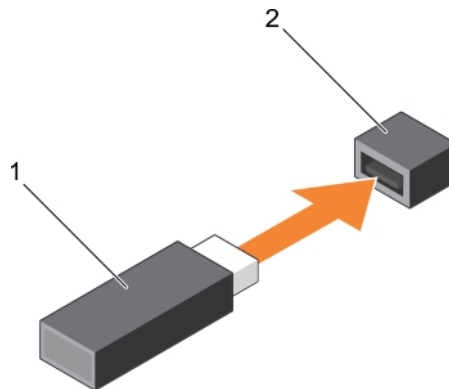

Figure 26. Installing the USB memory key

1 USB memory key

2 USB memory key connector

Next steps

- 1 Follow the procedure listed in the After working inside your system section.
- 2 Enter the System Setup and ensure that the USB key is detected by the system.

Related links

- [Safety instructions](#)
- [Before working inside your system](#)
- [After working inside your system](#)

Removing the optional IDSDM card

Prerequisites

CAUTION: Many repairs may only be done by a certified service technician. You should only perform troubleshooting and simple repairs as authorized in your product documentation, or as directed by the online or telephone service and support team. Damage due to servicing that is not authorized by Dell is not covered by your warranty. Read and follow the safety instructions that came with the product.

- 1 Follow the safety guidelines listed in safety instructions section.
- 2 Keep the Phillips #2 screwdriver ready.
- 3 Follow the procedure listed in After working inside your system.
- 4 If installed, remove the internal USB key.
- 5 If installed, remove the SD card(s).

Steps

- 1 Remove the two screws securing the IDSDM card to the system board.
- 2 Remove the SD card slot bracket.

CAUTION: To prevent damage to the IDSDM card, you must hold the card only by its edges.

- 3 Lift the card up and away from the system.

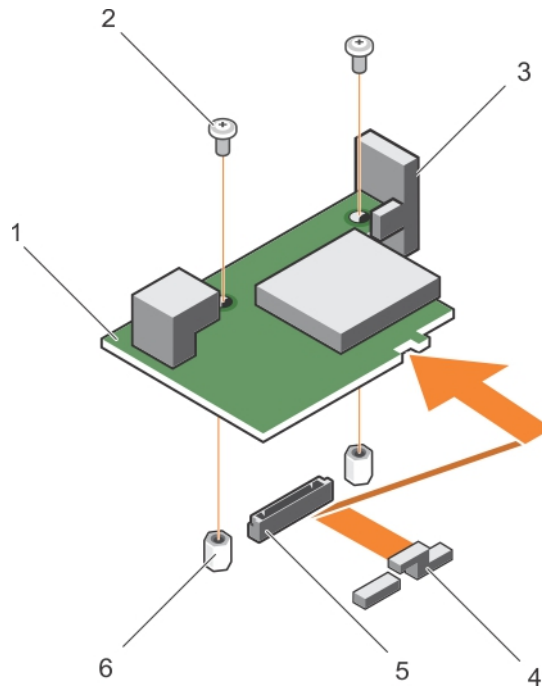

Figure 27. Removing the optional IDSDM card

- | | | | |
|---|--|---|-------------------------------------|
| 1 | IDSDM card | 2 | screw (2) |
| 3 | SD card slot bracket | 4 | PCIe mezzanine card support bracket |
| 5 | IDSDM card connector on the system board | 6 | standoff (2) |

Next steps

- 1 Install the IDSDM card.

- 2 Follow the procedure listed in the After working inside your system section.

Related links

- [Safety instructions](#)
- [Installing the optional IDSDM card](#)
- [Before working inside your system](#)
- [Replacing the internal USB key](#)
- [Replacing an SD card](#)
- [After working inside your system](#)

Installing the optional IDSDM card

Prerequisites

⚠ CAUTION: Many repairs may only be done by a certified service technician. You should only perform troubleshooting and simple repairs as authorized in your product documentation, or as directed by the online or telephone service and support team. Damage due to servicing that is not authorized by Dell is not covered by your warranty. Read and follow the safety instructions that came with the product.

ℹ NOTE: You must remove the IDSDM card to replace a faulty IDSDM card or service other components inside the system.

- 1 Follow the safety guidelines listed in safety instructions section.
- 2 Keep the Phillips #2 screwdriver ready.
- 3 Remove the SD card.
- 4 Remove the IDSDM card.

⚠ CAUTION: To prevent damage to the IDSDM card, you must hold the card only by its edges.

Steps

- 1 Align the following:
 - The slot on the card edge with the projection tabs on the PCIe mezzanine card support.
 - The two screw holes on the IDSDM card with the standoffs on the system board.
 - The hole on the SD card slot bracket with the screw hole on the IDSDM card.
- 2 Install the two screws to secure the SD card slot bracket and IDSDM card to the system board.

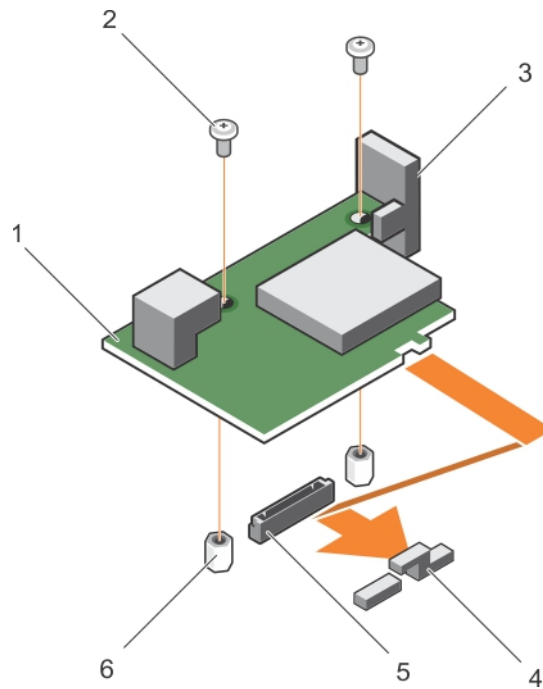

Figure 28. Installing the optional IDSDM card

- | | | | |
|---|--|---|-------------------------------------|
| 1 | IDSDM card | 2 | screw (2) |
| 3 | SD card slot bracket | 4 | PCIe mezzanine card support bracket |
| 5 | IDSDM card connector on the system board | 6 | standoff (2) |

Next steps

- 1 If applicable, install the SD card(s) and the internal USB key.
- 2 Follow the procedure listed in the After working inside your system section.

Related links

- [Safety instructions](#)
- [Removing the optional IDSDM card](#)
- [Replacing an SD card](#)
- [Replacing the internal USB key](#)
- [After working inside your system](#)

rSPI card (optional)

rSPI (restore Serial Peripheral Interface) is a SPI flash device to store information about the system Service Tag, system configuration, or iDRAC license.

Removing the optional rSPI card

Prerequisites

- ⚠ CAUTION:** Many repairs may only be done by a certified service technician. You should only perform troubleshooting and simple repairs as authorized in your product documentation, or as directed by the online or telephone service and support team. Damage due to servicing that is not authorized by Dell is not covered by your warranty. Read and follow the safety instructions that came with the product.

- 1 Follow the safety guidelines listed in safety instructions section.
- 2 Keep the Phillips #2 screwdriver ready.
- 3 Follow the procedure listed in the Before working inside your system section.

Steps

- 1 Remove the two screws securing the rSPI card to the system board.

△ CAUTION: To prevent damage to the rSPI card, you must hold the card only by its edges.

- 2 Lift the card up and away from the system.

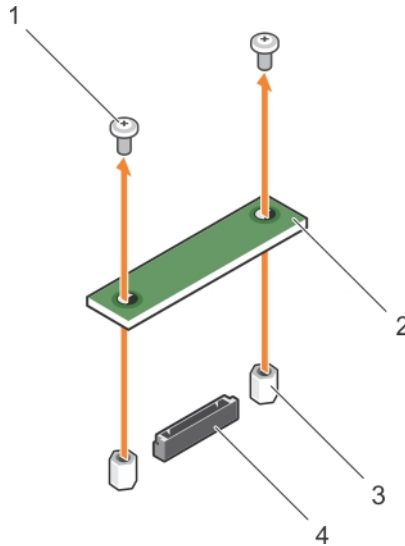

Figure 29. Removing the optional rSPI card

- | | | | |
|---|--------------|---|-----------|
| 1 | screw (2) | 2 | rSPI card |
| 3 | standoff (2) | 4 | connector |

Next steps

- 1 Install the rSPI card.
- 2 Follow the procedure listed in the After working inside your system section.

Related links

- [Safety instructions](#)
- [Before working inside your system](#)
- [Installing the optional rSPI card](#)
- [After working inside your system](#)

Installing the optional rSPI card

Prerequisites

△ CAUTION: Many repairs may only be done by a certified service technician. You should only perform troubleshooting and simple repairs as authorized in your product documentation, or as directed by the online or telephone service and support team. Damage due to servicing that is not authorized by Dell is not covered by your warranty. Read and follow the safety instructions that came with the product.

① NOTE: You must remove the rSPI card to replace a faulty rSPI card or service other components inside the system.

⚠ CAUTION: To prevent damage to the rSPI card, you must hold the card only by its edges.

- 1 Follow the safety guidelines listed in safety instructions section.
- 2 Keep the Phillips #2 screwdriver ready.
- 3 Remove the rSPI card.

Steps

- 1 Align the two screw holes on the rSPI card with the standoffs on the system board.
- 2 Install the two screws to secure the rSPI card to the system board.

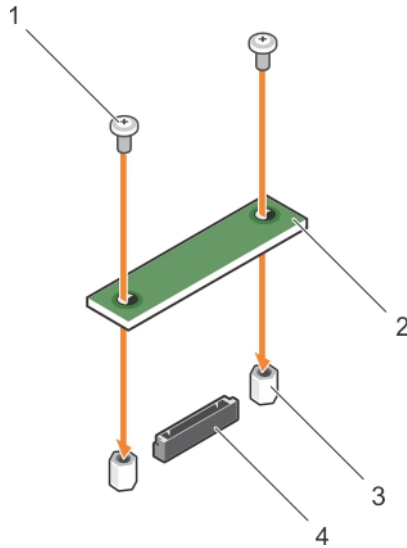

Figure 30. Installing the optional rSPI card

- | | | | |
|---|--------------|---|-----------|
| 1 | screw (2) | 2 | rSPI card |
| 3 | standoff (2) | 4 | connector |

Next step

Follow the procedure listed in the After working inside your system section.

Related links

- [Safety instructions](#)
- [Before working inside your system](#)
- [Removing the optional rSPI card](#)
- [After working inside your system](#)

SD vFlash card

A vFlash SD card is a Secure Digital (SD) card that plugs into the vFlash SD card slot in the system. It provides persistent on-demand local storage and a custom deployment environment that allows automation of server configuration, scripts, and imaging. It emulates USB devices. For more information, see the *Integrated Dell Remote Access Controller User's Guide* at **Dell.com/idracmanuals**.

You can use an SD vFlash card with your system. The card slot is on the IDSDM card. You can remove and install the SD vFlash card.

Replacing the SD vFlash card

Prerequisites

⚠ CAUTION: Many repairs may only be done by a certified service technician. You should only perform troubleshooting and simple repairs as authorized in your product documentation, or as directed by the online or telephone service and support team. Damage due to servicing that is not authorized by Dell is not covered by your warranty. Read and follow the safety instructions that came with the product.

- 1 Follow the safety guidelines listed in safety instructions section.
- 2 Follow the procedure listed in the Before working inside your system section.

Steps

- 1 If installed, remove the SD vFlash card from the card slot.

① NOTE: The SD vFlash card slot is near below the NDC.

- 2 Insert the contact-pin end of the SD card into the card slot on the vFlash media unit.

① NOTE: The slot is keyed to ensure correct insertion of the card.

- 3 Press inward on the card to lock it into the slot.

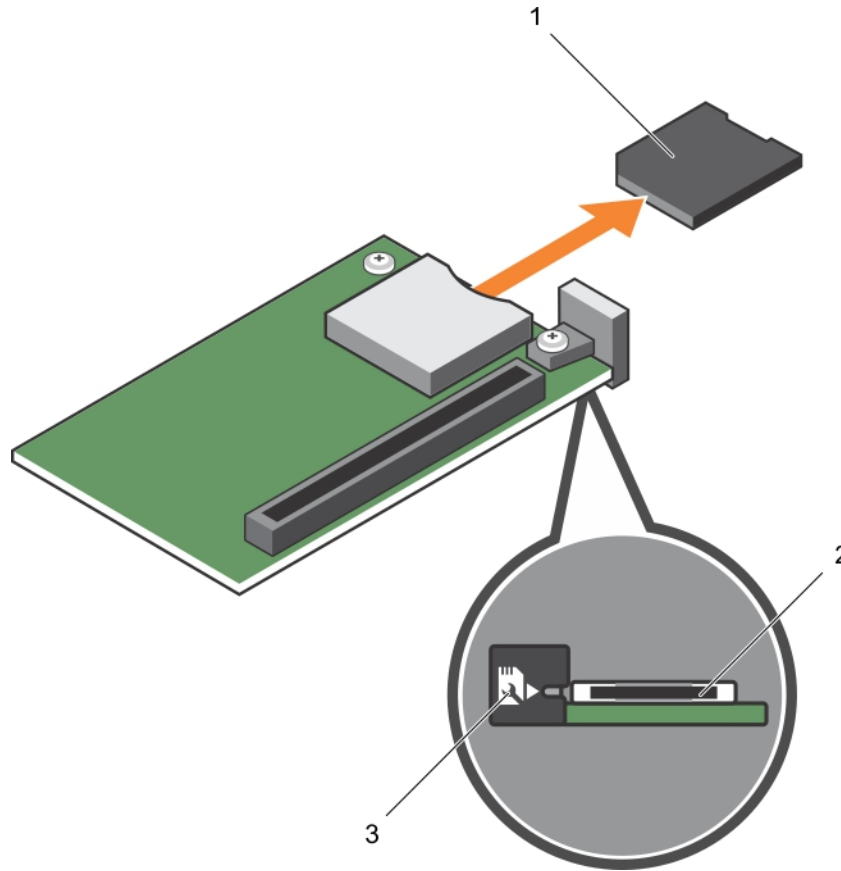

Figure 31. Replacing the SD vFlash card

- | | | | |
|---|--|---|---------------------|
| 1 | SD vFlash card | 2 | SD vFlash card slot |
| 3 | SD vFlash card slot identification label | | |

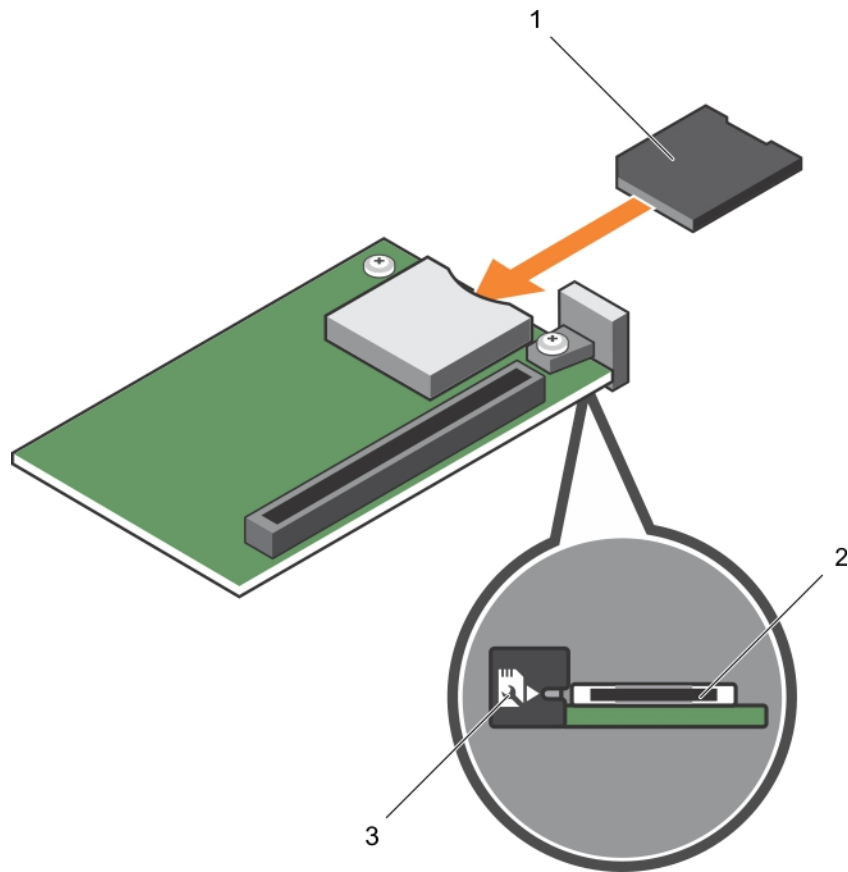

Figure 32. Installing the SD vFlash card

- 1 SD vFlash card
- 2 SD vFlash card slot
- 3 SD vFlash card slot identification label

Next step

Follow the procedure listed in the After working inside your system section.

Related links

- [Safety instructions](#)
- [Before working inside your system](#)
- [After working inside your system](#)

Network Daughter Card

The Network Daughter Card (NDC) is a small, removable mezzanine card. The NDC provides you with a flexibility of choosing different network connectivity option, for example—4 x 1GbE, 2 x 10GbE or 2 x Converged Network Adapter.

Removing the Network Daughter Card

Prerequisites

CAUTION: Many repairs may only be done by a certified service technician. You should only perform troubleshooting and simple repairs as authorized in your product documentation, or as directed by the online or telephone service and support team. Damage due to servicing that is not authorized by Dell is not covered by your warranty. Read and follow the safety instructions that came with the product.

- 1 Follow the safety guidelines listed in safety instructions section.
- 2 Keep the Phillips #2 screwdriver ready.
- 3 Follow the procedure listed in the Before working inside your system section.
- 4 Remove the PCIe mezzanine card.

Steps

- 1 Remove the two screws that secure the Network Daughter Card (NDC) to the system board.

⚠ CAUTION: To prevent damage to the NDC, you must hold the card only by its edges.

- 2 Lift the card from the system board.

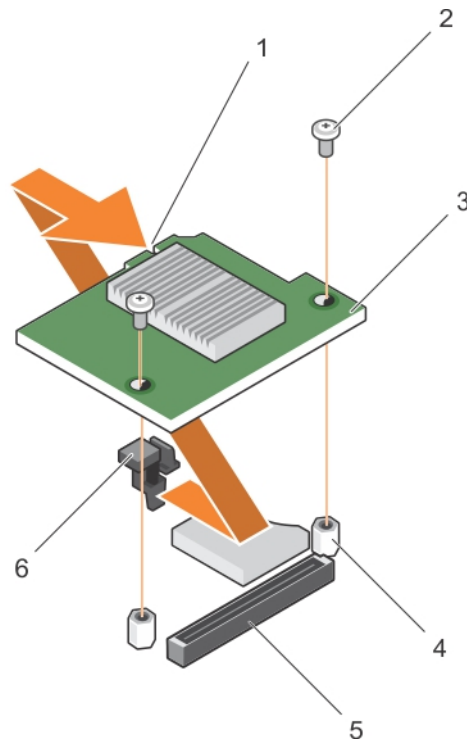

Figure 33. Removing the NDC

- | | |
|-------------------|-------------------|
| 1 slot on the NDC | 2 screw (2) |
| 3 NDC | 4 standoff (2) |
| 5 connector | 6 tab projections |

Next steps

- 1 Install the NDC.
- 2 Install the PCIe mezzanine card.
- 3 Follow the procedure listed in the After working inside your system section.

Related links

- [Safety instructions](#)
- [Before working inside your system](#)
- [Removing the PCIe mezzanine card](#)
- [Installing the Network Daughter Card](#)
- [Installing the PCIe mezzanine card](#)
- [After working inside your system](#)

Installing the Network Daughter Card

Prerequisites

CAUTION: Many repairs may only be done by a certified service technician. You should only perform troubleshooting and simple repairs as authorized in your product documentation, or as directed by the online or telephone service and support team. Damage due to servicing that is not authorized by Dell is not covered by your warranty. Read and follow the safety instructions that came with the product.

NOTE: You must remove the NDC to replace a faulty NDC card or service other components inside the system.

CAUTION: To prevent damage to the NDC, you must hold the card only by its edges.

- 1 Follow the safety guidelines listed in safety instructions section.
- 2 Keep the Phillips #2 screwdriver ready.
- 3 Remove the PCIe mezzanine card.
- 4 Remove the NDC.

Steps

- 1 Align the following:
 - a The slots on the card edge with the projection tabs on the plastic bracket covering the PCIe mezzanine card slots.
 - b Screw holes on the card with the standoffs on the system board.
- 2 Lower the card into place until the card connector fits into the corresponding connector on the system board.
- 3 Secure the card with the two screws.

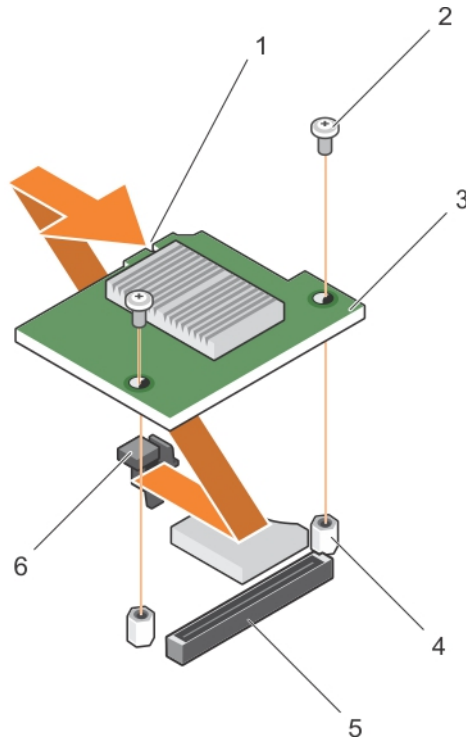

Figure 34. Installing the Network Daughter Card

- | | | | |
|---|-----------------|---|--------------|
| 1 | slot on the NDC | 2 | screw (2) |
| 3 | NDC | 4 | standoff (2) |

Next steps

- 1 Install the PCIe mezzanine card.
- 2 Follow the procedure listed in the After working inside your system section.

Related links

- [Safety instructions](#)
- [Removing the PCIe mezzanine card](#)
- [Removing the Network Daughter Card](#)
- [Installing the PCIe mezzanine card](#)
- [After working inside your system](#)

Processors

Your system supports one or two Intel Xeon E5-2600 v3 or E5-2600 v4 product family processors.

⚠ CAUTION: For processors of 105 W, 120 W, or 135 W, use heat sinks of 68 mm width.

ℹ NOTE: Mixing processors of different wattages is not supported.

Use the following procedure when:

- Removing and installing a heat sink
- Installing an additional processor
- Replacing a processor

ℹ NOTE: To ensure proper system cooling, you must install a processor blank in any empty processor socket.

Related links

- [Removing a heat sink](#)
- [Removing a processor](#)
- [Installing a processor](#)
- [Installing a heat sink](#)

Removing a heat sink

Prerequisites

⚠ CAUTION: Many repairs may only be done by a certified service technician. You should only perform troubleshooting and simple repairs as authorized in your product documentation, or as directed by the online or telephone service and support team. Damage due to servicing that is not authorized by Dell is not covered by your warranty. Read and follow the safety instructions that came with the product.

⚠ CAUTION: Never remove the heat sink from a processor unless you intend to remove the processor. The heat sink is necessary to maintain proper thermal conditions.

ℹ NOTE: The processor and heat sink can become extremely hot. Be sure the processor has had sufficient time to cool before handling.

- 1 Follow the safety guidelines listed in safety instructions section.
- 2 Keep the Phillips #2 screwdriver ready.
- 3 Follow the procedure listed in the Before working inside your system section.
- 4 Remove the cooling shroud.

Steps

- 1 Loosen the first screw that secures the heat sink to the system board.
Allow some time (around 30 seconds) for the heat sink to loosen from the processor.
- 2 Loosen the screw that is diagonally opposite the screw you first removed.
- 3 Repeat the procedure for the remaining two screws.
- 4 Remove the heat sink.

① **NOTE:** Set the heat sink upside down on the work surface to avoid contaminating the thermal grease.

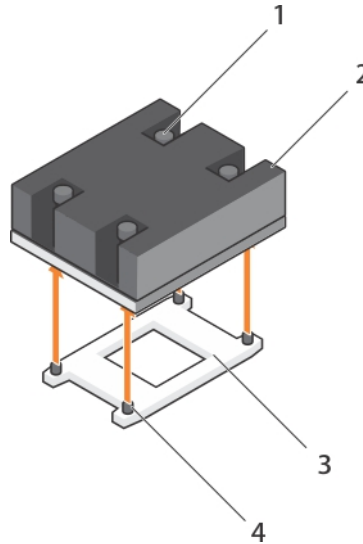

Figure 35. Removing a heat sink

- | | | | |
|---|---------------------|---|--------------------------------|
| 1 | retention screw (4) | 2 | heat sink |
| 3 | processor socket | 4 | heat sink retention socket (4) |

Next steps

- 1 Replace the heat sink(s) and processor(s).
- 2 Follow the procedure listed in the After working inside your system section.

Related links

[Safety instructions](#)
[Before working inside your system](#)
[After working inside your system](#)
[Removing the cooling shroud](#)
[Installing a heat sink](#)
[Installing a processor](#)

Removing a processor

Prerequisites

⚠ **CAUTION:** Many repairs may only be done by a certified service technician. You should only perform troubleshooting and simple repairs as authorized in your product documentation, or as directed by the online or telephone service and support team. Damage due to servicing that is not authorized by Dell is not covered by your warranty. Read and follow the safety instructions that came with the product.

CAUTION: Never remove the heat sink from a processor unless you intend to remove the processor. The heat sink is necessary to maintain proper thermal conditions.

NOTE: The processor and heat sink can become extremely hot. Be sure that the processor has had sufficient time to cool before handling.

- 1 Follow the safety guidelines listed in safety instructions section.
- 2 Keep the Phillips #2 screwdriver ready.
- 3 Follow the procedure listed in the Before working inside your system section.
- 4 Remove the cooling shroud.

Steps

- 1 Use a clean, lint-free cloth to remove any thermal grease from the surface of the processor shield.

CAUTION: The processor is held in its socket under strong pressure. The release lever can spring up suddenly if not firmly grasped.

- 2 Position your thumb firmly over the socket-release lever1 and lever 2 of the processor and release both the levers simultaneously from the locked position by pushing down and out from under the tab.

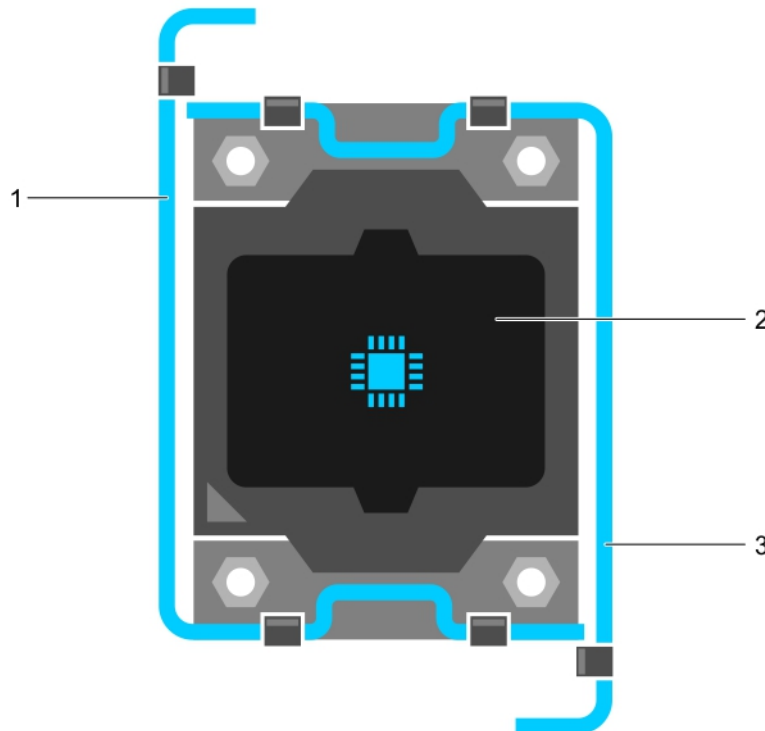

Figure 36. Processor shield opening and closing lever sequence

- | | | | |
|---|------------------------|---|-----------|
| 1 | socket-release lever 1 | 2 | processor |
| 3 | socket-release lever 2 | | |

- 3 Hold the tab on the processor shield and rotate the shield upward and out of the way.
- 4 Lift the processor out of the socket and leave the release lever up so that the socket is ready for the new processor.

CAUTION: If you are permanently removing a processor, you must install a socket protective cap and a processor/DIMM blank in the vacant socket to ensure proper system cooling. The processor/DIMM blank covers the vacant sockets for the DIMMs and the processor.

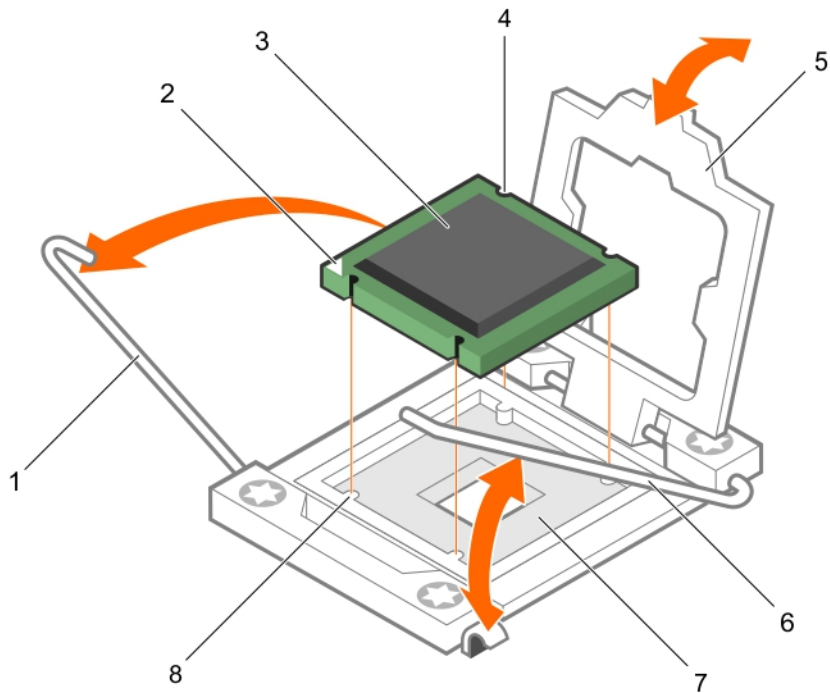

Figure 37. Installing and removing a processor

- | | | | |
|---|------------------------|---|-------------------------------|
| 1 | socket-release lever 1 | 2 | pin-1 corner of the processor |
| 3 | processor | 4 | slot (4) |
| 5 | processor shield | 6 | socket-release lever 2 |
| 7 | processor socket | 8 | tab (4) |

Example

Enter an example that illustrates the current task (optional).

Next steps

- 1 Replace the processor(s).
- 2 Install the heat sink.
- 3 Reinstall the cooling shroud.
- 4 Follow the procedure listed in the After working inside your system section.

Related links

- [Safety instructions](#)
- [Before working inside your system](#)
- [Installing the cooling shroud](#)
- [Removing a heat sink](#)
- [Installing a processor](#)
- [Installing a heat sink](#)
- [Removing the cooling shroud](#)
- [After working inside your system](#)

Installing a processor

Prerequisites

CAUTION: Many repairs may only be done by a certified service technician. You should only perform troubleshooting and simple repairs as authorized in your product documentation, or as directed by the online or telephone service and support team. Damage due to servicing that is not authorized by Dell is not covered by your warranty. Read and follow the safety instructions that came with the product.

NOTE: If you are installing just one processor, it must be installed in socket CPU1.

NOTE: You must remove a processor to upgrade a processor or replace a faulty processor.

- 1 Follow the safety guidelines listed in safety instructions section.
- 2 Keep the Phillips #2 screwdriver ready.
- 3 Follow the procedure listed in the Before working inside your system section.
- 4 Remove the processor or processor blank or DIMM blank.

Steps

- 1 Unlatch and rotate the socket-release levers 90 degrees upward and ensure that the socket-release lever is fully open.
- 2 Hold the tab on the processor shield and rotate the shield upward and out of the way.

NOTE: It is recommended that you install or remove the socket protective cap from the processor shield with the processor shield in the open position.

- 3 If installed, remove the socket protective cap from the processor shield. To remove the socket protective cap, push the cap from the inside of the processor shield and move it away from the socket pins.

CAUTION: Positioning the processor incorrectly can permanently damage the system board or the processor. Be careful not to bend the pins in the socket.

CAUTION: Do not use force to seat the processor. When the processor is positioned correctly, it engages easily into the socket.

- 4 Install the processor in the socket:
 - a Identify the pin-1 corner of the processor by locating the tiny gold triangle on one corner of the processor. Place this corner in the same corner of the ZIF socket identified by a corresponding triangle on the system board.
 - b Align the pin-1 corner of the processor with the pin-1 corner of the system board.
 - c Set the processor lightly in the socket.

Because the system uses a ZIF processor socket, do not use force. When the processor is positioned correctly, it drops down into the socket with minimal pressure.
 - d Close the processor shield.
 - e Rotate the socket-release lever 1 and lever 2 simultaneously until it is locked in position.

Next steps

- 1 Install the heat sink.
- 2 While booting, press F2 to enter System Setup and verify that the processor information matches the new system configuration.
- 3 Run the system diagnostics to verify that the new processor operates correctly.

Related links

- [Safety instructions](#)
- [Before working inside your system](#)
- [Removing the cooling shroud](#)
- [Installing a heat sink](#)
- [After working inside your system](#)

Installing a heat sink

Prerequisites

CAUTION: Many repairs may only be done by a certified service technician. You should only perform troubleshooting and simple repairs as authorized in your product documentation, or as directed by the online or telephone service and support team. Damage due to servicing that is not authorized by Dell is not covered by your warranty. Read and follow the safety instructions that came with the product.

NOTE: If you are installing just one processor, it must be installed in socket CPU1.

NOTE: You must remove a processor to upgrade a processor or replace a faulty processor.

- 1 Follow the safety guidelines listed in safety instructions section.
- 2 Keep the Phillips #2 screwdriver ready.
- 3 Follow the procedure listed in the Before working inside your system section.
- 4 Remove the cooling shroud
- 5 Remove the processor or processor blank/DIMM blank.

About this task

Enter the context of your task here (optional). This is where introductory content goes.

Step

To install the heat sink:

- a If applicable, remove the existing thermal grease from the heat sink by using a clean lint-free cloth.
- b Apply thermal grease on the top of the processor. Use the thermal-grease syringe included with your processor kit to apply the grease in a thin spiral on the top of the processor as shown in the figure.

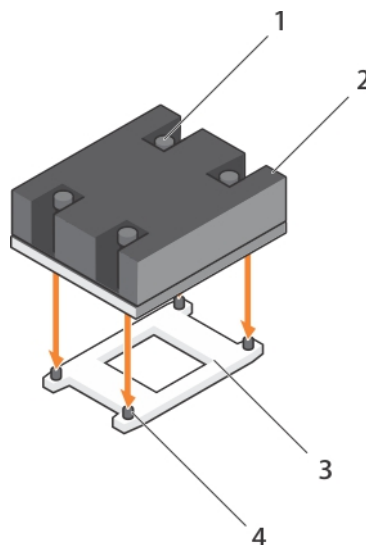

Figure 38. Installing a heat sink

- 1 retention screw (4)
- 3 processor socket

- 2 heat sink
- 4 heat sink retention socket (4)

CAUTION: Applying too much thermal grease can result in excess grease coming in contact with and contaminating the processor socket.

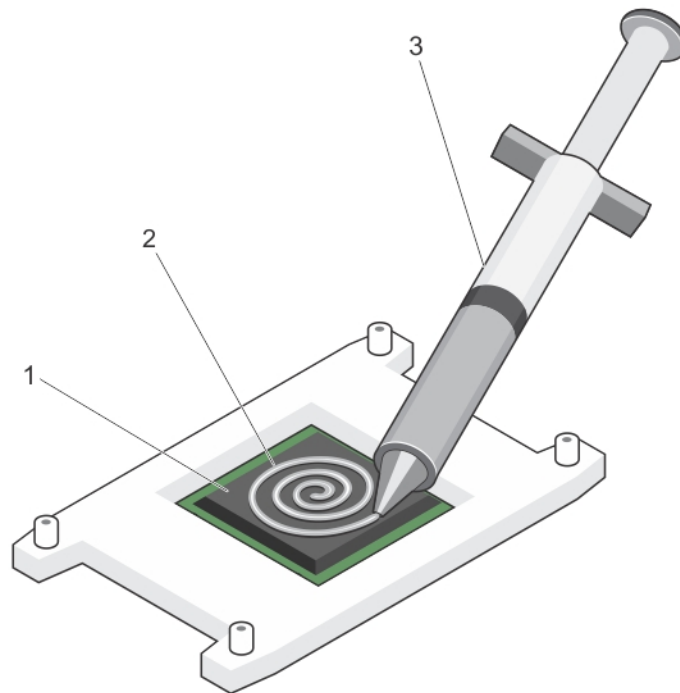

Figure 39. Applying thermal grease on the top of the processor

- 1 processor
- 2 thermal grease
- 3 thermal-grease syringe

NOTE: The thermal-grease is intended for one-time use only. Dispose of the syringe after you use it.

- c Place the heat sink onto the processor.
- d Tighten the four screws to secure the heat sink to the system board.

NOTE: Tighten the screws diagonally opposite to each other. Do not over-tighten the heat sink retention screws when installing the heat sink. To prevent over-tightening, tighten the retention screw until resistance is felt, and stop after the screw is seated. The screw tension should be no more than 6 in-lb (6.9 kg-cm).

Next steps

- 1 Install the cooling shroud.
- 2 Follow the procedure listed in the After working inside your system section.

As the system boots, it detects the presence of the new processor and automatically changes the system configuration information in the System Setup.

- 3 Press F2 to enter the System Setup and check that the processor information matches the new system configuration.
- 4 Run the system diagnostics to verify that the new processor operates correctly.
- 5 Update the system BIOS.

Related links

- [Safety instructions](#)
- [Before working inside your system](#)
- [Removing the cooling shroud](#)
- [Installing a processor](#)
- [Installing the cooling shroud](#)
- [After working inside your system](#)

Hard drives or SSDs

A hard disk drive (HDD), is a data storage device used for storing and retrieving digital information using one or more rigid rapidly rotating disks coated with magnetic material. A solid-state drive (SSD), is a solid-state storage device that uses integrated circuit assemblies as memory to store data persistently. SSDs have no moving components. SSDs are typically more resistant to physical shock, run silently, have lower access time, and less latency.

Your system supports up to two 2.5-inch SAS or SATA or PCIe SSDs or SAS or SATA hard drives and four 1.8-inch SATA SSDs. The hard drives or SSDs are supplied in special hot-swappable drive carriers that fit in the drive bays and these drives connect to the system board through the hard drive backplane board.

NOTE: Mixing of SSD or SAS or SATA hard drives is not supported.

Hard drive or SSD bay numbering

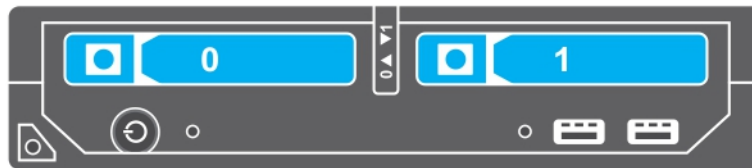

Figure 40. Hard drive or SSD bay numbering — 2.5-inch hard drive or SSD system

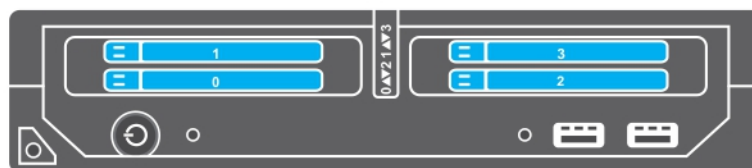

Figure 41. SSD bay numbering — 1.8-inch SSD system

Hard drive or SSD installation guidelines

For single hard drive configuration, a hard drive blank must be installed in the other drive bay to maintain proper cooling airflow.

Removing a hard drive or SSD

Prerequisites

CAUTION: Many repairs may only be done by a certified service technician. You should only perform troubleshooting and simple repairs as authorized in your product documentation, or as directed by the online or telephone service and support team. Damage due to servicing that is not authorized by Dell is not covered by your warranty. Read and follow the safety instructions that came with the product.

- 1 Follow the safety guidelines listed in safety instructions section.
- 2 Take the hard drive or SSD offline and wait until the hard drive or SSD indicator codes on the drive carrier stop blinking.

When all indicators stop blinking, the drive is ready for removal. See your operating system documentation for more information about taking the hard drive or SSD offline.

NOTE: All operating systems do not support hot-swappable drive installation. See the documentation supplied with your operating system.

Steps

- 1 Press the release button to open the hard drive or SSD carrier handle.
- 2 Slide the hard drive or SSD carrier out until it is free of the hard drive or SSD slot.
- 3 Slide the hard drive or SSD out until it is free of the hard drive or SSD bay.

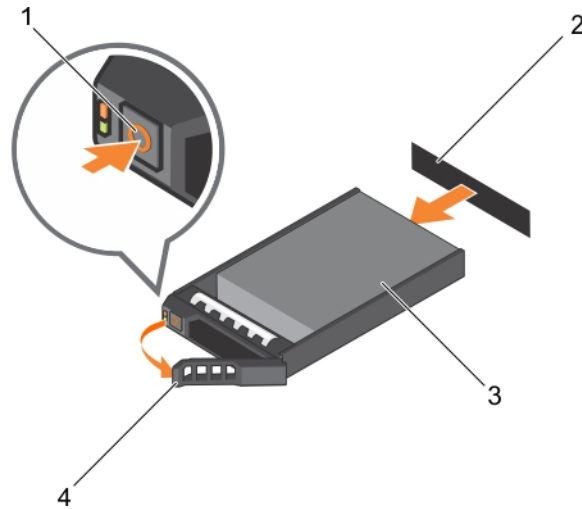

Figure 42. Removing a hard drive

- | | | | |
|---|-------------------|---|--|
| 1 | release button | 2 | hard drive or SSD connector (on backplane) |
| 3 | hard drive or SSD | 4 | hard drive or SSD carrier handle |

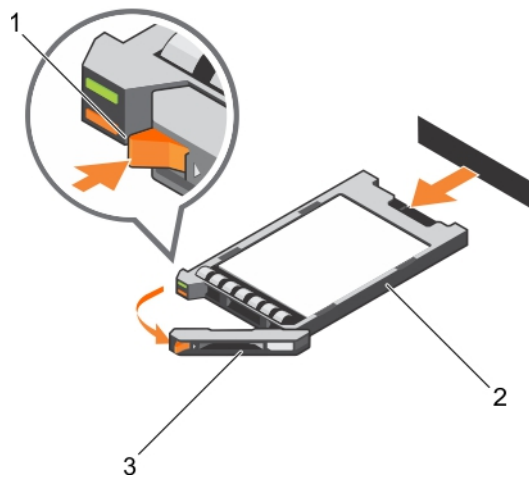

Figure 43. Removing a SSD

- 1 release button
- 2 SSD
- 3 SSD carrier handle

Next step

- 1 If you are removing a hard drive or SSD permanently, install the hard drive or SSD blank. If you are installing a new hard drive or SSD, see the Installing the hard drive or SSD section.

Related links

- [Safety instructions](#)
- [Installing a hard drive or SSD](#)
- [Hard drive or SSD indicator patterns](#)

Installing a hard drive or SSD

Prerequisites

⚠ CAUTION: When a replacement hot-swappable hard drive or SSD is installed and the server module is turned on, the hard drive or SSD automatically begins to rebuild. Make absolutely sure that the replacement hard drive or SSD is blank or contains data that you wish to have over-written. Any data on the replacement hard drive or SSD is immediately lost after the hard drive or SSD is installed.

ⓘ NOTE: You must remove a hard drive or SSD to upgrade a hard drive or SSD or replace a faulty hard drive or SSD.

- 1 Follow the safety guidelines listed in safety instructions section.
- 2 Remove the hard drive or SSD or hard drive or SSD blank.

ⓘ NOTE: All operating systems do not support hot-swappable drive installation. See the documentation supplied with your operating system.

Steps

- 1 Press the release button to open the hard drive or SSD carrier handle.
- 2 Slide the hard drive or SSD carrier into the drive bay. Carefully align the channel on the hard drive or SSD carrier with the appropriate drive slot on the server module.
- 3 Push the drive carrier into the slot until the handle makes contact with the server module.
- 4 Rotate the carrier handle to the closed position while pushing the carrier into the slot until it locks into place.
The status LED indicator displays a steady green light if the drive is installed correctly. The drive carrier LED green indicator flashes as the drive rebuilds.

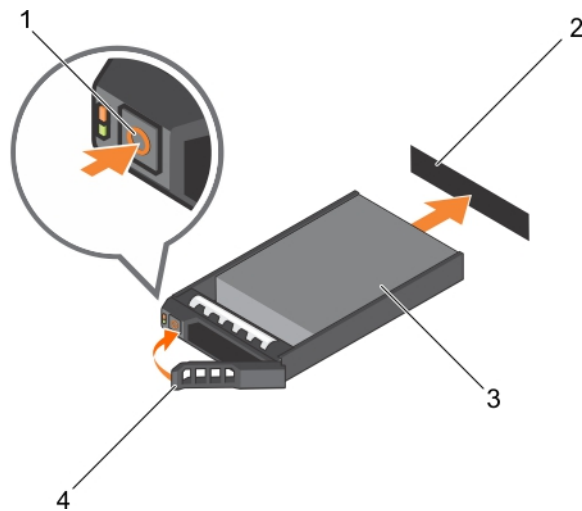

Figure 44. Installing a hard drive

- | | | | |
|---|----------------|---|---------------------------|
| 1 | release button | 2 | hard drive(on backplane) |
| 3 | hard drive | 4 | hard drive carrier handle |

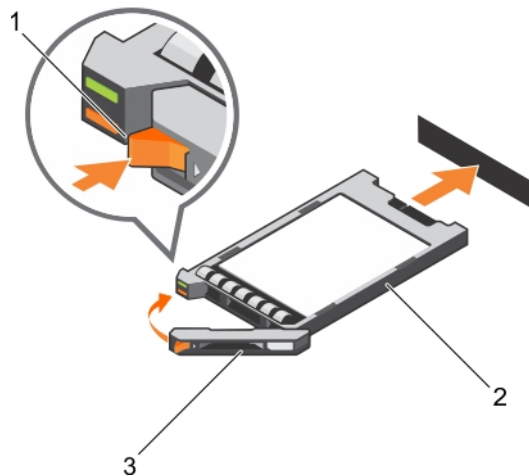

Figure 45. Installing a SSD

- | | | | |
|---|--------------------|---|-----|
| 1 | release button | 2 | SSD |
| 3 | SSD carrier handle | | |

Related link

[Safety instructions](#)

Removing a hard drive or SSD blank

Prerequisites

⚠ CAUTION: Many repairs may only be done by a certified service technician. You should only perform troubleshooting and simple repairs as authorized in your product documentation, or as directed by the online or telephone service and support team. Damage due to servicing that is not authorized by Dell is not covered by your warranty. Read and follow the safety instructions that came with the product.

⚠ CAUTION: To maintain proper system cooling, all empty hard drive or SSD slots must have hard drive or SSD blanks installed.

- 1 Follow the safety guidelines listed in safety instructions section.

Step

Press the release latch and slide the hard drive or SSD blank out of the hard drive or SSD slot.

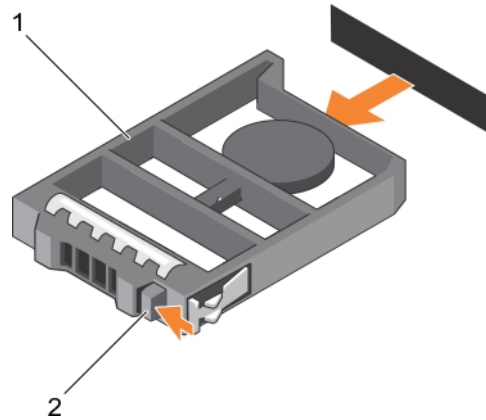

Figure 46. Removing a 2.5-inch hard drive

1 hard drive or SSD blank

2 release latch

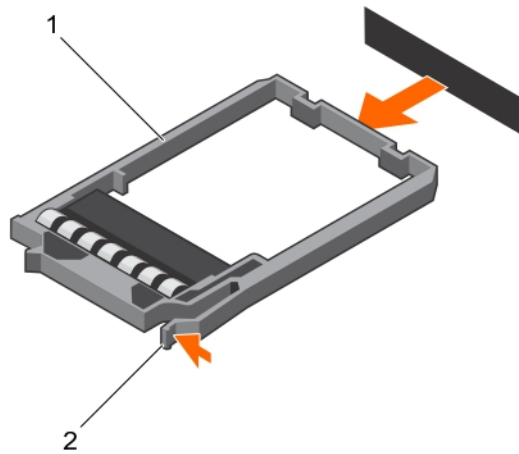

Figure 47. Removing a 1.8-inch SSD blank

1 SSD blank

2 release latch

Next step

- 1 Install the hard drive or SSD.

Related links

- [Safety instructions](#)
- [Installing a hard drive or SSD](#)

Installing a hard drive or SSD blank

Prerequisites

- 1 Follow the safety guidelines listed in safety instructions section.
- 2 Remove a hard drive or SSD.

Step

Insert the hard drive or SSD blank into the hard drive or SSD slot until the release latch clicks into place.

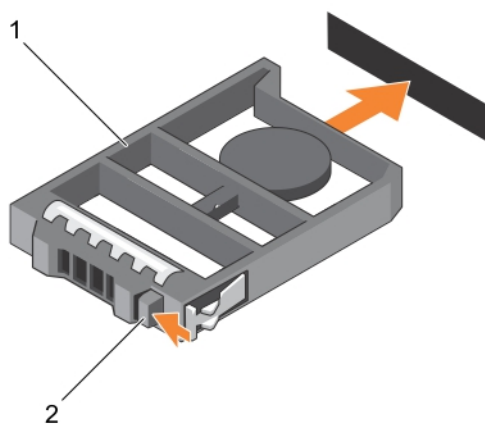

Figure 48. Installing a 2.5-inch hard drive blank

1 hard drive or SSD blank

2 release latch

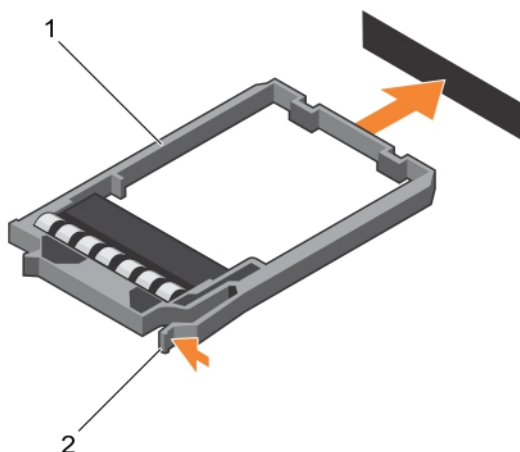

Figure 49. Installing a 1.8-inch SSD blank

1 SSD blank

2 release latch

Related links

[Safety instructions](#)

[Removing a hard drive or SSD](#)

Shutdown procedure for servicing a hard drive

NOTE: This section applies only to situations where the server module must be turned off to service a hard drive. In many situations, the hard drive can be serviced while the server module is turned on.

If you need to turn off the server module to service a hard drive, wait 30 seconds after the server module power indicator turns off before removing the hard drive. Otherwise, the hard drive may not be recognized after it is reinstalled and the server module is turned on again.

Configuring the boot drive

The drive or device from which the system boots is determined by the boot order specified in the System Setup.

Removing a 2.5-inch hard drive or SSD from a 2.5-inch hard drive or SSD carrier

Prerequisite

CAUTION: Many repairs may only be done by a certified service technician. You should only perform troubleshooting and simple repairs as authorized in your product documentation, or as directed by the online or telephone service and support team. Damage due to servicing that is not authorized by Dell is not covered by your warranty. Read and follow the safety instructions that came with the product.

1 Follow the safety guidelines listed in safety instructions section.

- 2 Keep the Phillips #1 screwdriver ready.

Steps

- 1 Remove the four screws from the slide rails on the hard drive or SSD carrier.
- 2 Slide the hard drive or SSD out of the hard drive or SSD carrier.

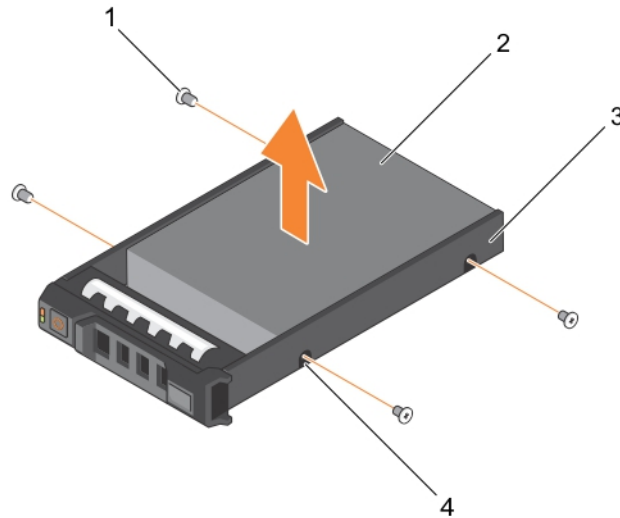

Figure 50. Removing a 2.5-inch hard drive or SSD in a 2.5-inch hard drive or SSD carrier

- | | | | |
|---|---------------------------|---|-------------------|
| 1 | screw (4) | 2 | hard drive or SSD |
| 3 | hard drive or SSD carrier | 4 | screw hole (4) |

Next step

Install a new 2.5-inch hard drive or SSD in a 2.5-inch hard drive or SSD carrier.

Related links

- [Safety instructions](#)
- [Installing a 2.5-inch hard drive or SSD in a 2.5-inch hard drive or SSD carrier](#)

Installing a 2.5-inch hard drive or SSD in a 2.5-inch hard drive or SSD carrier

Prerequisites

- ⚠ CAUTION:** Many repairs may only be done by a certified service technician. You should only perform troubleshooting and simple repairs as authorized in your product documentation, or as directed by the online or telephone service and support team. Damage due to servicing that is not authorized by Dell is not covered by your warranty. Read and follow the safety instructions that came with the product.

NOTE: You must remove the hard drive or SSD from a hard drive or SSD carrier to replace a faulty hard drive or SSD from a hard drive or SSD carrier.

- 1 Follow the safety guidelines listed in safety instructions section.
- 2 Keep the Phillips #1 screwdriver ready.
- 3 Remove the 2.5-inch hard drive or SSD from the 2.5-inch hard drive or SSD carrier.

Steps

- 1 Slide the hard drive or SSD into the hard drive or SSD carrier.
- 2 Align the screw holes on the hard drive or SSD with the holes on the hard drive or SSD carrier.

CAUTION: To avoid damaging the drive or the carrier, do not overtighten the screws.

- 3 Fasten the four screws to secure the hard drive or SSD to the hard drive or SSD carrier.

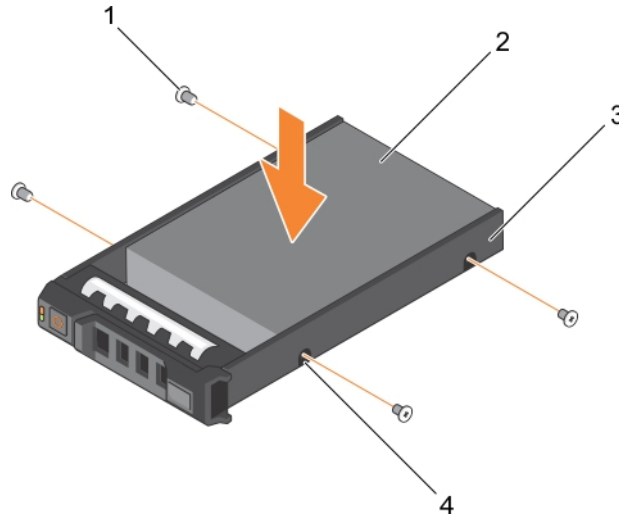

Figure 51. Installing a 2.5-inch hard drive or SSD in a 2.5-inch hard drive or SSD carrier

- | | | | |
|---|---------------------------|---|-------------------|
| 1 | screw (4) | 2 | hard drive or SSD |
| 3 | hard drive or SSD carrier | 4 | screw hole (4) |

Related links

[Safety instructions](#)

[Removing a 2.5-inch hard drive or SSD from a 2.5-inch hard drive or SSD carrier](#)

Removing a 1.8-inch SSD from a 1.8-inch SSD carrier

Prerequisite

CAUTION: Many repairs may only be done by a certified service technician. You should only perform troubleshooting and simple repairs as authorized in your product documentation, or as directed by the online or telephone service and support team. Damage due to servicing that is not authorized by Dell is not covered by your warranty. Read and follow the safety instructions that came with the product.

Follow the safety guidelines listed in safety instructions section.

Step

Pull the rails on the side of the carrier and lift the SSD out of the carrier.

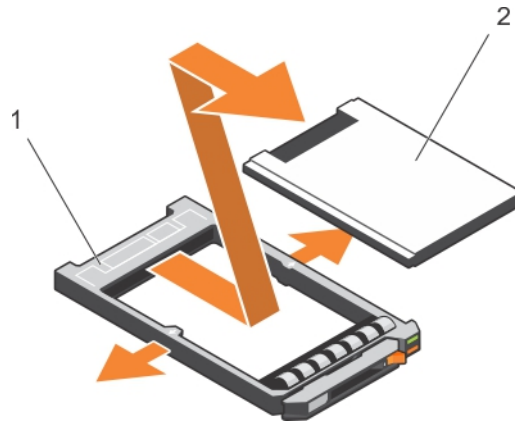

Figure 52. Removing a 1.8-inch SSD in a 1.8-inch SSD carrier

1 SSD carrier

2 SSD

Next step

Install a 1.8-inch SSD in a 1.8-inch SSD carrier.

Related links

[Safety instructions](#)

[Installing a 1.8-inch SSD in a 1.8-inch SSD carrier](#)

Installing a 1.8-inch SSD in a 1.8-inch SSD carrier

Prerequisites

⚠ CAUTION: Many repairs may only be done by a certified service technician. You should only perform troubleshooting and simple repairs as authorized in your product documentation, or as directed by the online or telephone service and support team. Damage due to servicing that is not authorized by Dell is not covered by your warranty. Read and follow the safety instructions that came with the product.

ℹ NOTE: You must remove the SSD from a SSD carrier to replace a faulty SSD from a SSD carrier.

- 1 Follow the safety guidelines listed in safety instructions section.
- 2 Remove a 1.8-inch SSD from a 1.8-inch SSD carrier.

Step

Insert the SSD into the SSD carrier with the connector end of the SSD toward the back. When aligned correctly, the back of the SSD is flush with the back of the SSD carrier.

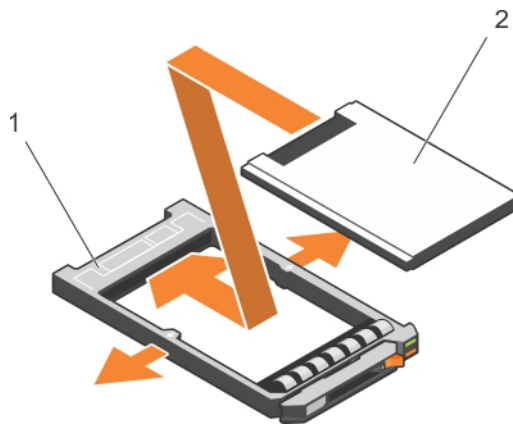

Figure 53. Installing a 1.8-inch SSD in a 1.8-inch SSD carrier

1 SSD carrier

2 SSD

Related links

[Safety instructions](#)

[Removing a 1.8-inch SSD from a 1.8-inch SSD carrier](#)

Removing the hard drive or SSD cage

Prerequisites

⚠ CAUTION: Many repairs may only be done by a certified service technician. You should only perform troubleshooting and simple repairs as authorized in your product documentation, or as directed by the online or telephone service and support team. Damage due to servicing that is not authorized by Dell is not covered by your warranty. Read and follow the safety instructions that came with the product.

- 1 Follow the safety guidelines listed in safety instructions section.
- 2 Keep the Phillips #1 screwdriver ready.
- 3 Follow the procedure listed in the Before working inside your system section.
- 4 Remove the hard drive(s) or SSD(s).
- 5 Remove the hard drive or SSD backplane.

Steps

- 1 Remove the four screws securing the hard drive or SSD cage to the chassis.
- 2 Holding the hard drive or SSD cage by its edges, lift it up and away from the system.

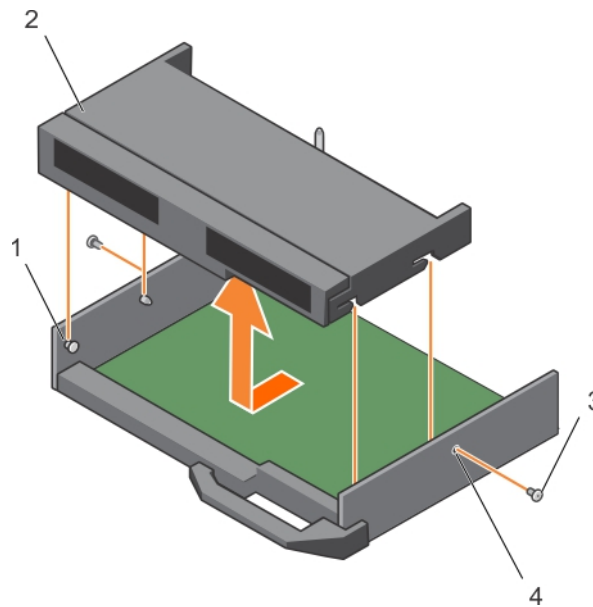

Figure 54. Removing a hard drive or SSD cage

- | | | | |
|---|--------------|---|------------------------|
| 1 | standoff (4) | 2 | hard drive or SSD cage |
| 3 | screw (2) | 4 | screw hole (2) |

Next steps

- 1 Install the hard drive or SSD cage.
- 2 Install the hard drive or SSD backplane.
- 3 Install the hard drive(s) or SSD(s).
- 4 Follow the procedure listed in the After working inside your system section.

Related links

- [Safety instructions](#)
- [Removing the hard drive or SSD backplane](#)
- [Installing the hard drive or SSD cage](#)
- [After working inside your system](#)
- [Removing a hard drive or SSD](#)

Installing the hard drive or SSD cage

Prerequisites

- ⚠ CAUTION:** Many repairs may only be done by a certified service technician. You should only perform troubleshooting and simple repairs as authorized in your product documentation, or as directed by the online or telephone service and support team. Damage due to servicing that is not authorized by Dell is not covered by your warranty. Read and follow the safety instructions that came with the product.
- ℹ NOTE:** You must remove the hard drive or SSD cage to replace a faulty hard drive or SSD cage or service other components inside the system.

- 1 Follow the safety guidelines listed in safety instructions section.
- 2 Keep the Phillips #1 screwdriver ready.
- 3 Remove the hard drive or SSD cage.

Steps

- 1 Align the screw holes on the hard drive or SSD cage with the screw holes on the chassis.
- 2 Lower the hard drive or SSD cage into the chassis until it is seated firmly in place.
- 3 Install the four screws to secure the hard drive or SSD cage to the chassis.

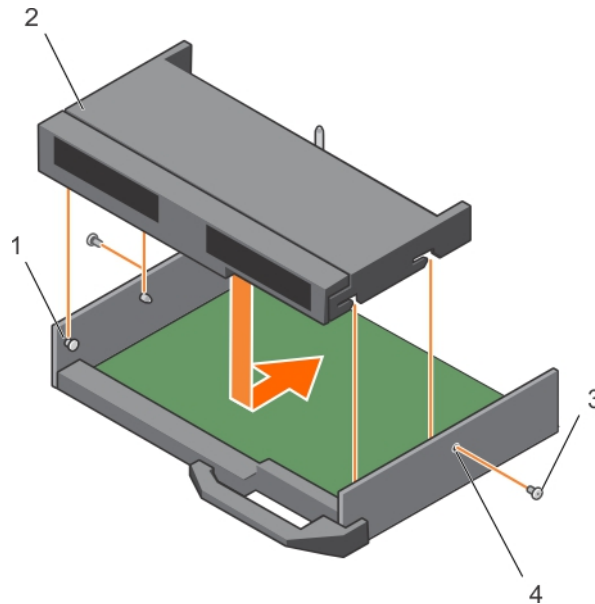

Figure 55. Installing a hard drive or SSD cage

- | | | | |
|---|--------------|---|------------------------|
| 1 | standoff (4) | 2 | hard drive or SSD cage |
| 3 | screw (2) | 4 | screw hole (2) |

Next steps

- 1 Install the hard drive or SSD backplane.
- 2 Install the hard drive or SSDs.
- 3 Follow the procedure listed in the After working inside your system section.

Related links

- [Safety instructions](#)
- [Removing the hard drive or SSD cage](#)
- [Installing the hard drive or SSD backplane](#)
- [After working inside your system](#)
- [Installing a hard drive or SSD](#)

Hard drive or SSD backplane

Systems use a backplane to attach hot-swappable hard drives. A backplane has pins that pass directly into hard drive sockets without cables. They may have single connector to connect one disk array controller or multiple connectors that can be connected to one or more controllers.

Removing the hard drive or SSD backplane

Prerequisites

- △ **CAUTION:** Many repairs may only be done by a certified service technician. You should only perform troubleshooting and simple repairs as authorized in your product documentation, or as directed by the online or telephone service and support team. Damage due to servicing that is not authorized by Dell is not covered by your warranty. Read and follow the safety instructions that came with the product.
- △ **CAUTION:** To prevent damage to the hard drives or SSDs and the hard drive or SSD backplane, you must remove the hard drives or SSDs from the server module before removing the hard drive or SSD backplane.
- △ **CAUTION:** Note the number of each hard drive or SSD and temporarily label them before removal so that you can replace them in the same locations.

- 1 Follow the safety guidelines listed in safety instructions section.
- 2 Keep the Phillips #2 screwdriver ready.
- 3 Follow the procedure listed in the Before working inside your system section.
- 4 Remove the hard drive(s) or SSD(s).

Steps

- 1 Pressing the release latches, hold both the edges of the backplane near the server module chassis and lift it up and away from the system.
- 2 Remove the hard drive or SSD cage.
- 3 Loosen the two retention screws securing the hard drive or SSD backplane cable connector to the system board connector.
- 4 Lift the hard drive or SSD backplane up and away from the system.

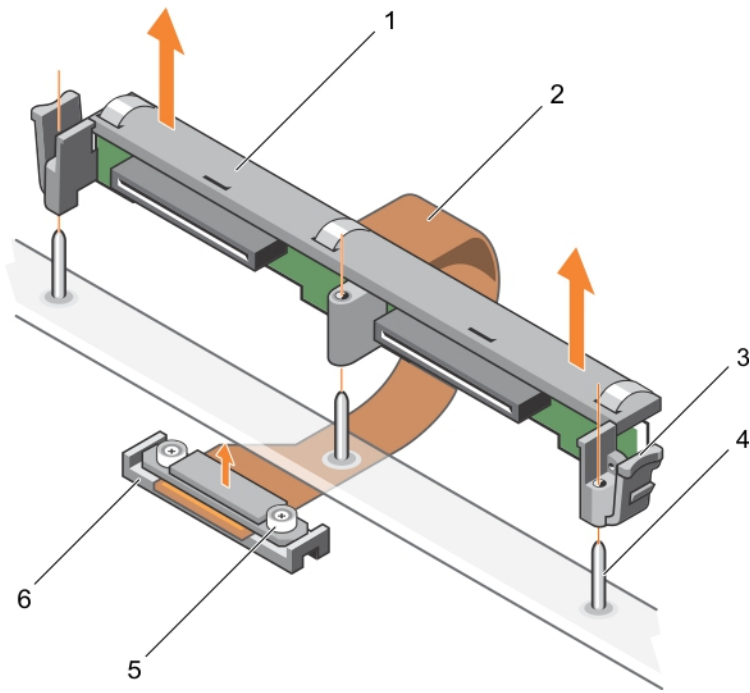

Figure 56. Removing the 2.5-inch (x2) hard drive or SSD backplane

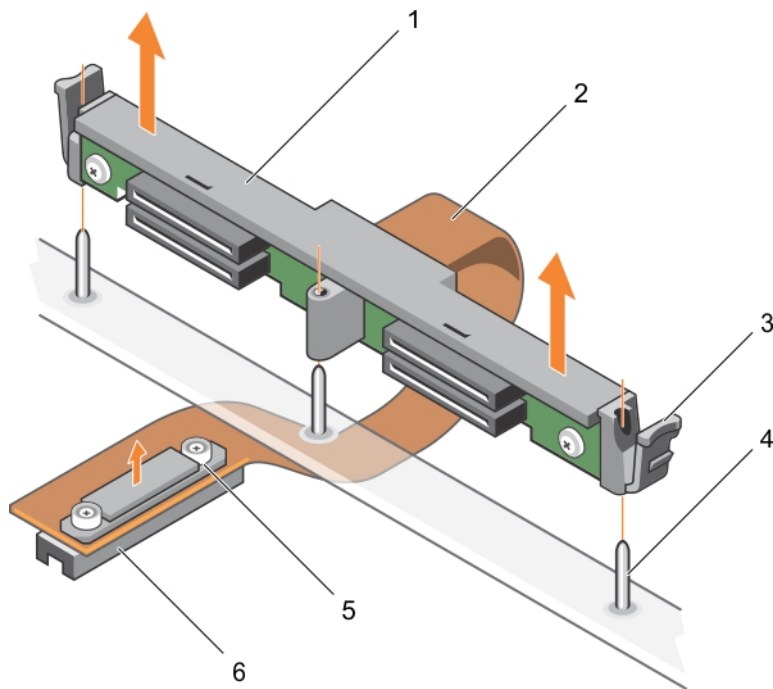

Figure 57. Removing the 1.8-inch (x4) SSD backplane

- | | | | |
|---|--|---|-----------------------------------|
| 1 | hard drive or SSD backplane | 2 | hard drive or SSD backplane cable |
| 3 | release latch (2) | 4 | guide pin (3) |
| 5 | retention screw on the backplane cable connector (2) | 6 | connector on system board |

Next steps

- 1 Install the hard drive or SSD backplane.
- 2 Install the hard drive or SSD.
- 3 Follow the procedure listed in the After working inside your system section.

Related links

- [Safety instructions](#)
- [Before working inside your system](#)
- [Installing the hard drive or SSD backplane](#)
- [Removing a hard drive or SSD](#)
- [Removing the hard drive or SSD cage](#)
- [After working inside your system](#)

Installing the hard drive or SSD backplane

Prerequisites

⚠ CAUTION: Many repairs may only be done by a certified service technician. You should only perform troubleshooting and simple repairs as authorized in your product documentation, or as directed by the online or telephone service and support team. Damage due to servicing that is not authorized by Dell is not covered by your warranty. Read and follow the safety instructions that came with the product.

ℹ NOTE: You must remove the hard drive or SSD backplane to replace a faulty hard drive or SSD backplane or service other components inside the system.

- 1 Follow the safety guidelines listed in safety instructions section.
- 2 Keep the Phillips #2 screwdriver ready.
- 3 Remove the hard drive or SSD. .
- 4 Remove the hard drive or SSD backplane.

Steps

- 1 Align the retention screws on the hard drive or SSD backplane cable connector with the screw holes on the system board connector.
- 2 Tighten the two retention screws to secure the backplane cable connector on the system board.
- 3 Install the hard drive or SSD cage.
- 4 Align the guides on the hard drive or SSD backplane with the guide pins on the hard drive or SSD cage.
- 5 Pressing the release latches, lower the hard drive or SSD backplane into the system until it is firmly seated, and the latches engage with the chassis.

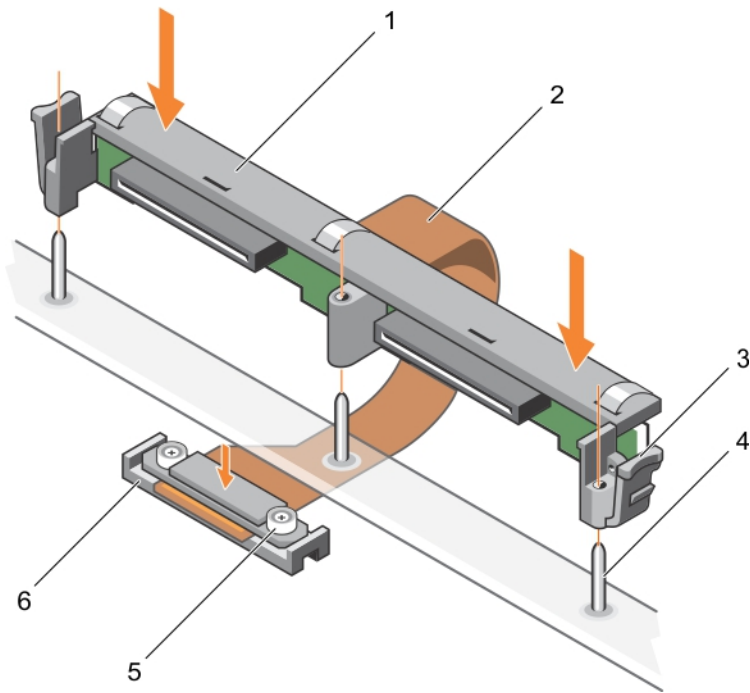

Figure 58. Installing the 2.5-inch (x2) hard drive or SSD backplane

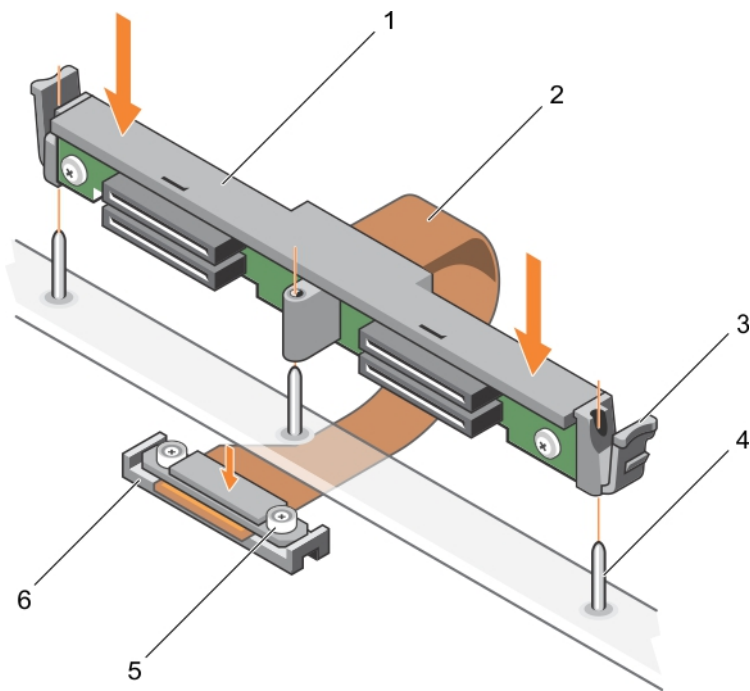

Figure 59. Installing the 1.8-inch (x4) SSD backplane

- | | | | |
|---|--|---|-----------------------------------|
| 1 | hard drive or SSD backplane | 2 | hard drive or SSD backplane cable |
| 3 | release latch (2) | 4 | guide pin (3) |
| 5 | retention screw on the backplane cable connector (2) | 6 | connector on system board |

Next steps

- 1 Install the hard drives or SSDs in their original locations.
- 2 Follow the procedure listed in the After working inside your system section.

Related links

- [Safety instructions](#)
- [Removing a hard drive or SSD](#)
- [Removing the hard drive or SSD backplane](#)
- [After working inside your system](#)
- [Installing the hard drive or SSD cage](#)
- [Installing a hard drive or SSD](#)

Storage controller card

Your system includes a dedicated expansion card slot on the server module system board for a storage controller card that provides the integrated storage subsystem for your system's hard drives. The storage controller card supports SAS HDDs, SATA HDDs, and PCIe SSDs.

 **NOTE:** The storage controller card is located underneath the hard drive bays.

Removing the PCIe extender or storage controller card

Prerequisites

 **CAUTION:** Many repairs may only be done by a certified service technician. You should only perform troubleshooting and simple repairs as authorized in your product documentation, or as directed by the online or telephone service and support team. Damage due to servicing that is not authorized by Dell is not covered by your warranty. Read and follow the safety instructions that are shipped with your product.

 **NOTE:** PCIe extender or storage controller card is supported on systems with the SAS backplanes.

- 1 Follow the safety guidelines listed in safety instructions section.
- 2 Keep the Phillips #2 screwdriver ready.
- 3 Follow the procedure listed in the Before working inside your system section..
- 4 Remove the following:
 - a Hard drives or SSDs
 - b Hard drive or SSD backplane
 - c Hard drive or SSD cage

Steps

- 1 Loosen the two retention screws on the hard drive or SSD backplane cable connector and lift it away from the PCIe extender or storage controller card.

 **CAUTION:** To prevent damage to the PCIe extender or storage controller card, you must hold the card only by its edges.

- 2 Lift the PCIe extender or storage controller card up and away from the system.

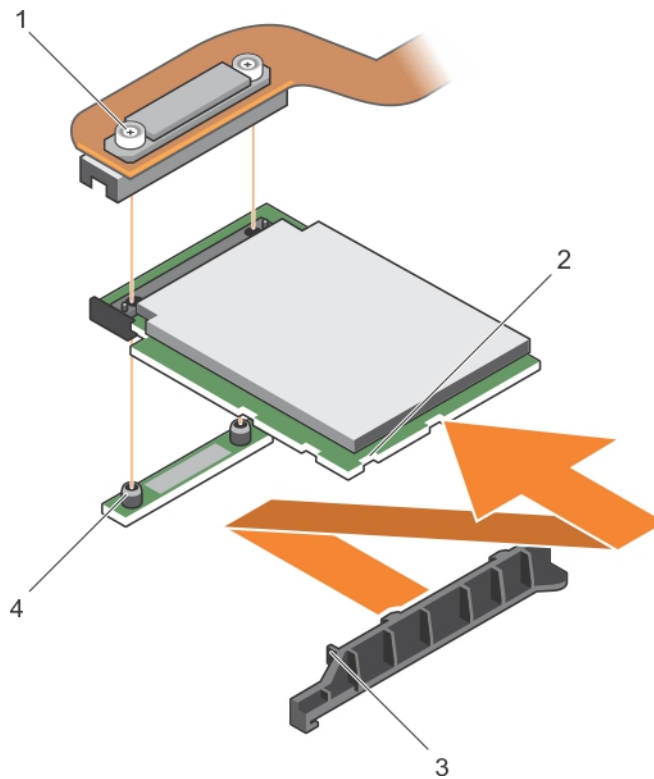

Figure 60. Removing the PCIe extender or storage controller card

- | | | | |
|---|---|---|--|
| 1 | retention screw (2) | 2 | slot on the PCIe extender or storage controller card |
| 3 | tab on the PCIe extender or storage controller card support bracket | 4 | standoff (2) |

Next steps

- 1 Install the PCIe extender or storage controller card.
- 2 Install the following:
 - a Hard drive or SSD cage
 - b Hard drive or SSD backplane
 - c Hard drives or SSDs
- 3 Follow the procedure listed in the After working inside your system section.

Related links

- [Safety instructions](#)
- [Before working inside your system](#)
- [Installing the PCIe extender or storage controller card](#)
- [After working inside your system](#)
- [Removing a hard drive or SSD](#)
- [Removing the hard drive or SSD cage](#)
- [Removing the hard drive or SSD backplane](#)

Installing the PCIe extender or storage controller card

Prerequisites

⚠ CAUTION: Many repairs may only be done by a certified service technician. You should only perform troubleshooting and simple repairs as authorized in your product documentation, or as directed by the online or telephone service and support team. Damage due to servicing that is not authorized by Dell is not covered by your warranty. Read and follow the safety instructions that came with the product.

ⓘ NOTE: PCIe extender or storage controller card is supported on systems with the SAS backplanes.

ⓘ NOTE: You must remove the PCIe extender or storage controller card to replace a faulty PCIe extender or storage controller card or service other components inside the system.

- 1 Follow the safety guidelines listed in safety instructions section.
- 2 Keep the Phillips #2 screwdriver ready.
- 3 Remove the PCIe extender or storage controller card.

Steps

- 1 Align the slots on the PCIe extender or storage controller card edge with the tabs on the support bracket.

⚠ CAUTION: To prevent damage to the PCIe extender or storage controller card, you must hold the card only by its edges.

- 2 Lower the PCIe extender or storage controller card on to the connector on the system board.
- 3 Tighten the two retention screws on the hard drive or SSD backplane cable connector to secure the card on to the system board.

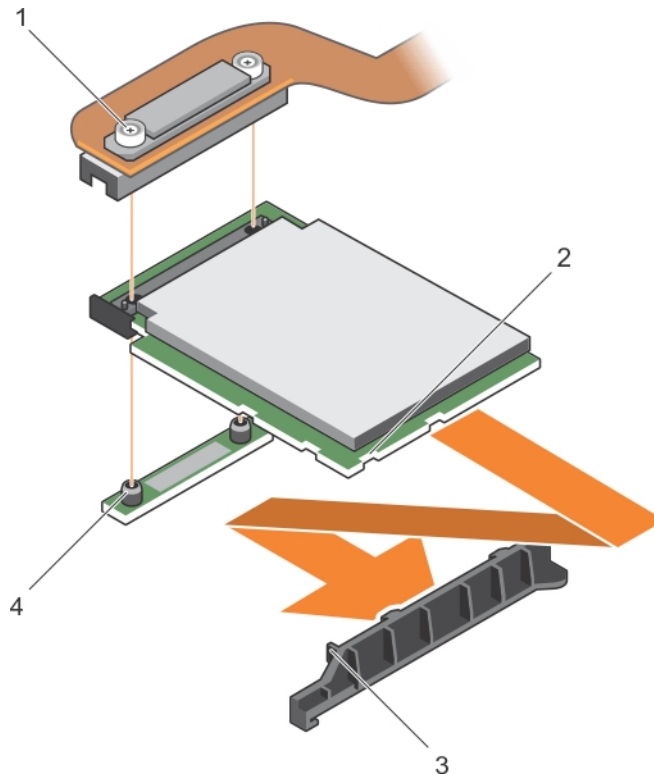

Figure 61. Installing the PCIe extender or storage controller card

1 retention screw (2)

2 slot on the PCIe extender or storage controller card

3 tab on the PCIe extender or storage controller card support bracket

4 standoff (2)

Next steps

- 1 Install the following:
 - a Hard drives or SSDs
 - b Hard drive or SSD backplane
 - c Hard drive or SSD cage
- 2 Follow the procedure listed in the After working inside your system section..

Related links

[Safety instructions](#)
[Removing the PCIe extender or storage controller card](#)
[After working inside your system](#)
[Installing the hard drive or SSD cage](#)
[Installing the hard drive or SSD backplane](#)
[Installing a hard drive or SSD](#)

System board

A system board (also known as the motherboard) is the main printed circuit board found in computers. The system board allows communication between many of the crucial electronic components of the computer, such as the central processing unit (CPU) and memory, and also provides connectors for other peripherals. Unlike a backplane, a system board contains significant number subsystems such as the processor expansion cards, and other components.

Removing the system board

Prerequisites

⚠ CAUTION: Many repairs may only be done by a certified service technician. You should only perform troubleshooting and simple repairs as authorized in your product documentation, or as directed by the online or telephone service and support team. Damage due to servicing that is not authorized by Dell is not covered by your warranty. Read and follow the safety instructions that came with the product.

- 1 Follow the safety guidelines listed in safety instructions section.
- 2 Keep the Phillips #2 screwdriver and the Hex nut driver-5 mm ready.
- 3 Follow the procedure listed in the Before working inside your system section.
- 4 Remove the following:
 - a Processor(s) and heat sink(s)
 - b Memory modules
 - c Cooling shroud
 - d Hard drive or SSDs
 - e Hard drive or SSD backplane
 - f Hard drive or SSD cage
 - g PCIe extender or storage controller card
 - h PCIe mezzanine cards
 - i IDSDM or rSPI card

- j NDC
- k SD vFlash card
- l Internal USB key

5 Install an I/O connector cover on the I or O connector(s) at the back of the board.

⚠ WARNING: The processor and heat sink can become extremely hot. Be sure the processor has had sufficient time to cool before handling.

⚠ WARNING: The memory modules are hot to touch for some time after the system has been powered down. Allow time for the memory modules to cool before handling them. Handle the memory modules by the card edges and avoid touching the components.

⚠ CAUTION: Do not lift the system board by holding a memory module, processor, or other components.

⚠ CAUTION: Temporarily label the hard drive or SSD before removal so that you can replace them in their original locations.

Steps

- 1 Remove the screws on the system board that secure the system board to the chassis.
- 2 Lift the system board by holding the connector end and orienting it upward.
- 3 Remove the system board from the chassis by disengaging the USB connectors from the slots on the front wall of the chassis.
- 4 Ensure that the I/O connector cover is still in place on the I or O connector at the back of the system board.

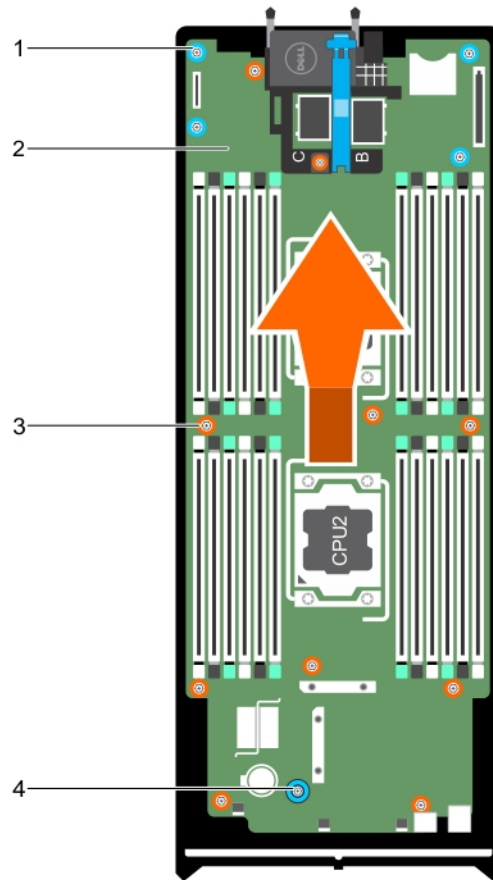

Figure 62. Removing the system board

- | | | | |
|---|-------------------|---|---------------------|
| 1 | hex nut screw (4) | 2 | system board |
| 3 | screw (10) | 4 | system board handle |

Next steps

- 1 Install the system board.
- 2 Follow the procedure listed in the After working inside your system section.

Related links

- [Safety instructions](#)
- [Before working inside your system](#)
- [Installing the system board](#)
- [After working inside your system](#)
- [Removing a heat sink](#)
- [Removing memory modules](#)
- [Removing the cooling shroud](#)
- [Removing a hard drive or SSD](#)
- [Removing the hard drive or SSD backplane](#)
- [Removing the hard drive or SSD cage](#)
- [Removing the PCIe mezzanine card](#)
- [Removing the Network Daughter Card](#)
- [Replacing the internal USB key](#)

Installing the system board

Prerequisites

⚠ CAUTION: Many repairs may only be done by a certified service technician. You should only perform troubleshooting and simple repairs as authorized in your product documentation, or as directed by the online or telephone service and support team. Damage due to servicing that is not authorized by Dell is not covered by your warranty. Read and follow the safety instructions that came with the product.

- 1 Follow the safety guidelines listed in safety instructions section.
- 2 Keep the Phillips #2 screwdriver and the Hex nut driver-5 mm ready.
- 3 Unpack the new system board assembly.

⚠ CAUTION: Do not lift the system board by holding a memory module, processor, or other components.

⚠ CAUTION: Take care not to damage the system identification button while placing the system board into the chassis.

Steps

- 1 Hold the system board by the connector end and orient it toward the front of the chassis.
- 2 Align the USB connectors with the slots on the front wall of the chassis.
- 3 Lower the system board and install the screws to secure the system board to the chassis.

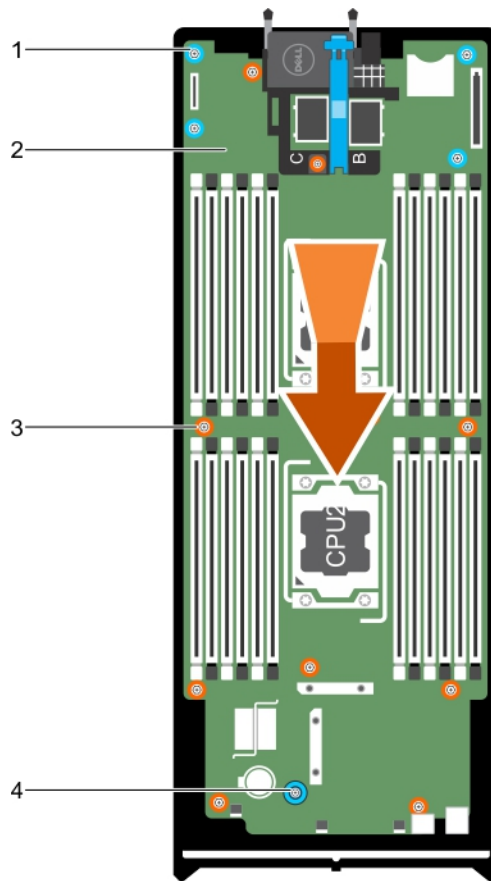

Figure 63. Installing the system board

- | | | | |
|---|-------------------|---|---------------------|
| 1 | hex nut screw (4) | 2 | system board |
| 3 | screw (10) | 4 | system board handle |

Next steps

- 1 Install the following:
 - a Internal USB key
 - b SD vFlash card
 - c IDSDM or rSPI card
 - d NDC
 - e PCIe mezzanine cards
 - f PCIe extender or storage controller card
 - g Hard drive or SSD cage
 - h Hard drive or SSD backplane
 - i Hard drive(s) or SSD(s)

NOTE: Ensure that you reinstall the hard drives or SSDs in their original locations.

- j Cooling shroud
- k Memory modules
- l Processor(s) and heat sink(s)

- 2 Remove the plastic I/O connector covers from the back of the system.
- 3 Follow the procedure listed in the After working inside your system section.
- 4 Import your new or existing iDRAC Enterprise license. For more information, see the *iDRAC8 User's Guide* at Dell.com/idracmanuals.
- 5 Ensure that you:
 - a Use the Easy Restore feature to restore the Service Tag. For more information, see the Restoring the Service Tag by using Easy Restore section.
 - b If the Service Tag is not backed up in the backup flash device, enter the system Service Tag manually. For more information, see the Restoring the Service Tag by using Easy Restore section.
 - c Update the BIOS and iDRAC versions.
 - d Reenable the Trusted Platform Module (TPM). For more information, see the Reenabling the TPM for BitLocker users section or the Reenabling the TPM for Intel TXT users section.

Related links

- [Safety instructions](#)
- [Removing the system board](#)
- [Installing the Trusted Platform Module](#)
- [Trusted Platform Module](#)
- [After working inside your system](#)
- [Restoring the Service Tag by using the Easy Restore feature](#)
- [Entering the system Service Tag by using System Setup](#)
- [Initializing the TPM for BitLocker users](#)
- [Initializing the TPM for TXT users](#)
- [Replacing the internal USB key](#)
- [Installing the optional IDSDM card](#)
- [Installing the optional rSPI card](#)
- [Installing the Network Daughter Card](#)
- [Installing the PCIe mezzanine card](#)
- [Installing the PCIe extender or storage controller card](#)
- [Installing the hard drive or SSD cage](#)
- [Installing the hard drive or SSD backplane](#)
- [Installing a hard drive or SSD](#)
- [Installing the cooling shroud](#)
- [Installing memory modules](#)
- [Installing a processor](#)

Restoring the Service Tag by using the Easy Restore feature

The Easy Restore feature enables you to restore your system's Service Tag, license, UEFI configuration, and the system configuration data after replacing the system board. All data is automatically backed up in a backup flash device. If BIOS detects a new system board and the Service Tag in the backup flash device, BIOS prompts the user to restore the backup information.

- 1 Turn on the system.

If BIOS detects a new system board, and if the Service Tag is present in the backup flash device, BIOS displays the Service Tag, the status of the license, and the **UEFI Diagnostics** version.
- 2 Perform one of the following steps:
 - Press **Y** to restore the Service Tag, license, and diagnostics information.
 - Press **N** to navigate to the Dell Lifecycle Controller based restore options.
 - Press F10 to restore data from a previously created **Hardware Server Profile**.

After the restore process is complete, BIOS prompts to restore the system configuration data.

- 3 Perform one of the following steps:
 - Press **Y** to restore the system configuration data.

- Press **N** to use the default configuration settings.

After the restore process is complete, the system restarts.

Entering the system Service Tag by using System Setup

If Easy Restore fails to restore the Service Tag, use System Setup to enter the Service Tag.

- 1 Turn on the system.
- 2 Press F2 to enter System Setup.
- 3 Click **Service Tag Settings**.
- 4 Enter the Service Tag.

NOTE: You can enter the Service Tag only when the Service Tag field is empty. Ensure that you enter the correct Service Tag. After the Service Tag is entered, it cannot be updated or changed.

- 5 Click **Ok**.
- 6 Import your new or existing iDRAC Enterprise license.

For more information, see the *Integrated Dell Remote Access Controller User's Guide* at Dell.com/idracmanuals.

Trusted Platform Module

Trusted Platform Module (TPM) is a dedicated microprocessor designed to secure hardware by integrating cryptographic keys into devices. A software can use a Trusted Platform Module to authenticate hardware devices. As each TPM chip has a unique and secret RSA key burned in as it is produced, it can perform the platform authentication.

CAUTION: Do not attempt to remove the Trusted Platform Module (TPM) from the system board. After the TPM is installed, it is cryptographically bound to that specific system board. Any attempt to remove an installed TPM breaks the cryptographic binding, and it cannot be re-installed or installed on another system board.

NOTE: This is a Field Replaceable Unit (FRU). Removal and installation procedures must be performed only by Dell certified service technicians.

Installing the Trusted Platform Module

Prerequisites

CAUTION: Many repairs may only be done by a certified service technician. You should only perform troubleshooting and simple repairs as authorized in your product documentation, or as directed by the online or telephone service and support team. Damage due to servicing that is not authorized by Dell is not covered by your warranty. Read and follow the safety instructions that came with the product.

- 1 Follow the safety guidelines listed in the Safety instructions section.
- 2 Follow the procedure listed in the Before working inside your system section.

Steps

- 1 Locate the Trusted Platform Module (TPM) connector on the system board.

NOTE: To locate the TPM connector on the system board, see the System board connectors section.

- 2 Align the edge connectors on the TPM with the slot on the TPM connector.
- 3 Insert the TPM into the TPM connector such that the plastic bolt aligns with the slot on the system board.
- 4 Press the plastic bolt until the bolt snaps into place.

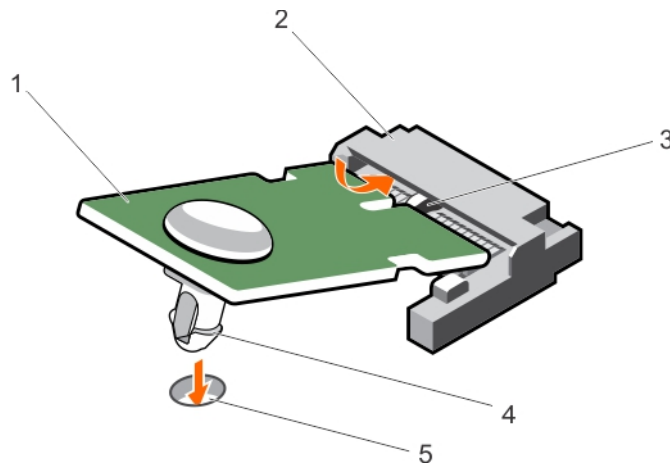

Figure 64. Installing the TPM

- | | | | |
|---|---------------------------|---|---------------|
| 1 | TPM | 2 | TPM connector |
| 3 | slot on the TPM connector | 4 | plastic bolt |
| 5 | slot on the system board | | |

Next steps

- 1 Install the system board.
- 2 Follow the procedure listed in the After working inside your system section.

Related links

- [Safety instructions](#)
- [System board connectors](#)

Initializing the TPM for BitLocker users

Initialize the TPM.

For more information about initializing the TPM, see <http://technet.microsoft.com/en-us/library/cc753140.aspx>.

The **TPM Status** changes to **Enabled, Activated**.

Initializing the TPM for TXT users

- 1 While booting your system, press F2 to enter System Setup.
- 2 On the **System Setup Main Menu** screen, click **System BIOS** → **System Security Settings**.
- 3 From the **TPM Security** option, select **On with Pre-boot Measurements**.
- 4 From the **TPM Command** option, select **Activate**.
- 5 Save the settings.
- 6 Restart your system.
- 7 Enter **System Setup** again.
- 8 On the **System Setup Main Menu** screen, click **System BIOS** → **System Security Settings**.
- 9 From the **Intel TXT** option, select **On**.

NVRAM backup battery

The NVRAM backup battery installed in your system helps to retain the BIOS settings and configurations even if the power is switched off.

Replacing the NVRAM backup battery

Prerequisites

⚠ WARNING: There is a danger of a new battery exploding if it is incorrectly installed. Replace the battery only with the same or equivalent type recommended by the manufacturer. Discard used batteries according to the manufacturer's instructions. See the safety instructions that came with your system for additional information.

⚠ CAUTION: Many repairs may only be done by a certified service technician. You should only perform troubleshooting and simple repairs as authorized in your product documentation, or as directed by the online or telephone service and support team. Damage due to servicing that is not authorized by Dell is not covered by your warranty. Read and follow the safety instructions that are shipped with your product.

- 1 Follow the safety guidelines listed in safety instructions section.
- 2 Follow the procedure listed in the Before working inside your system section.
- 3 Remove the following:
 - a Hard drives or SSDs
 - b Cooling shroud
 - c Hard drive or SSD backplane
 - d Hard drive or SSD cage
 - e PCIe mezzanine card
 - f NDC
 - g IDSDM or rSPI card
 - h System board

Steps

- 1 Locate the system battery on the system.
- 2 To remove the battery, press down firmly on the positive side of the connector and lift the battery out of the securing tabs at the negative side of the connector.
- 3 To install a new system battery:
 - a Support the battery connector by pressing down firmly on the positive side of the connector.
 - b Hold the battery with the "+" facing up and slide it under the securing tabs at the positive side of the connector.
- 4 Press the battery straight down into the connector until it snaps into place.

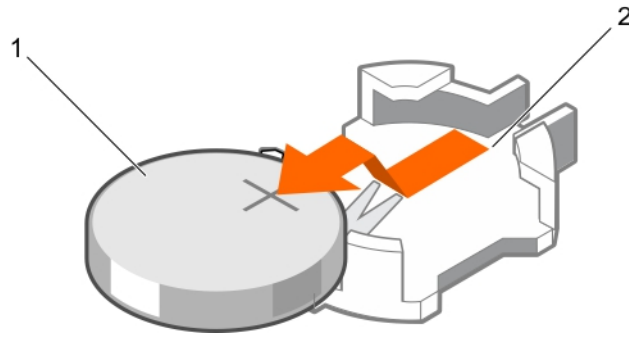

Figure 65. Removing the NVRAM backup battery

1 positive side of battery

2 negative side of battery connector

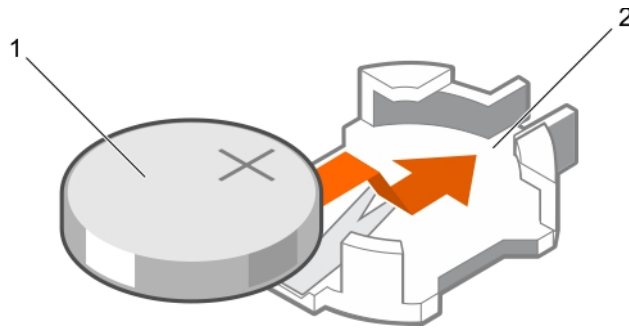

Figure 66. Installing the NVRAM backup battery

1 positive side of battery

2 negative side of battery connector

Next steps

- 1 Install the following:
 - a System board
 - b IDSDM or rSPI card
 - c NDC
 - d PCIe mezzanine cards
 - e Hard drive or SSD cage
 - f Hard drive or SSD backplane
 - g Cooling shroud
 - h Hard drives or SSDs
- 2 Follow the procedure listed in the After working inside your system section.
- 3 Enter the System Setup to confirm that the battery is operating properly.
- 4 Enter the correct time and date in the System Setup's **Time** and **Date** fields.
- 5 Exit the System Setup.
- 6 To test the newly installed battery, remove the server module for at least an hour.
- 7 Reinstall the server module after an hour.
- 8 Enter the System Setup and if the time and date are still incorrect, see the Getting help section.

Related links

[Getting help](#)
[Safety instructions](#)
[Before working inside your system](#)
[After working inside your system](#)
[Removing a hard drive or SSD](#)
[Removing the cooling shroud](#)
[Removing the hard drive or SSD backplane](#)
[Removing the hard drive or SSD cage](#)
[Removing the PCIe mezzanine card](#)
[Removing the Network Daughter Card](#)
[Removing the optional IDSDM card](#)
[Removing the optional rSPI card](#)
[Removing the system board](#)
[Installing the system board](#)
[Installing the optional IDSDM card](#)
[Installing the optional rSPI card](#)
[Installing the Network Daughter Card](#)
[Installing the PCIe mezzanine card](#)
[Installing the hard drive or SSD cage](#)
[Installing the hard drive or SSD backplane](#)
[Installing the cooling shroud](#)
[Installing a hard drive or SSD](#)
[Removing a server module](#)
[Installing a server module](#)

Using system diagnostics

If you experience a problem with your system, run the system diagnostics before contacting Dell for technical assistance. The purpose of running system diagnostics is to test your system hardware without requiring additional equipment or risking data loss. If you are unable to fix the problem yourself, service and support personnel can use the diagnostics results to help you solve the problem.

Dell Embedded System Diagnostics

NOTE: The Dell Embedded System Diagnostics is also known as Enhanced Pre-boot System Assessment (ePSA) diagnostics.

The Embedded System Diagnostics provides a set of options for particular device groups or devices allowing you to:

- Run tests automatically or in an interactive mode
- Repeat tests
- Display or save test results
- Run thorough tests to introduce additional test options to provide extra information about the failed device(s)
- View status messages that inform you if tests are completed successfully
- View error messages that inform you of problems encountered during testing

Running the Embedded System Diagnostics

Run the Embedded System Diagnostics (ePSA) if your system does not boot. The embedded system diagnostics program is run from the Dell Lifecycle Controller.

Prerequisite

If a major component or device in the system does not operate properly, running the embedded system diagnostics may indicate component failure.

CAUTION: Use the embedded system diagnostics to test only your system. Using this program with other systems may cause invalid results or error messages.

Steps

- 1 As the system boots, press F11.
- 2 Use the up and down arrow keys to select **System Utilities > Launch Dell Diagnostics**.
The **ePSA Pre-boot System Assessment** window is displayed, listing all devices detected in the system. The diagnostics starts running the tests on all the detected devices.

Running embedded system diagnostics from an external media

- 1 Format the external resource media (USB flash drive or CDROM) to emulate a hard drive.
See the documentation that came with the resource media for instructions.
- 2 Configure the resource media to be a bootable device.
- 3 Create a directory for the system diagnostics on the resource media.
- 4 Copy the system diagnostics files into the directory.
To download the Dell diagnostics utility, go to **Dell.com/support/home**.
- 5 Connect the resource media on your system.

- 6 As the system boots, press F11.
- 7 When prompted, select the media to perform a one-time boot.
If diagnostics does not start automatically after the diagnostic media is booted, enter **psa** at the command prompt.

System diagnostics controls

Menu	Description
Configuration	Displays the configuration and status information of all detected devices.
Results	Displays the results of all tests that are run.
System Health	Provides the current overview of the system performance.
Event Log	Displays a time-stamped log of the results of all tests run on the system. This is displayed if at least one event description is recorded.

For information about embedded system diagnostics, see the *Dell Enhanced Pre-boot System Assessment User Guide* at [Dell.com/support/home](https://www.dell.com/support/home).

Jumpers and connectors

This topic provides specific information about the system jumpers. It also provides some basic information about jumpers and switches and describes the connectors on the various boards in the system. Jumpers on the system board help to disable system and setup passwords. You must know the connectors on the system board to install components and cables correctly.

Topics:





- [System board jumper settings](#)
- [System board connectors](#)
- [Disabling a forgotten password](#)

System board jumper settings

⚠ CAUTION: Many repairs may only be done by a certified service technician. You should only perform troubleshooting and simple repairs as authorized in your product documentation, or as directed by the online or telephone service and support team. Damage due to servicing that is not authorized by Dell is not covered by your warranty. Read and follow the safety instructions that came with the product.

For information on resetting the password jumper to disable a password, see the [Disabling A Forgotten Password](#) section.

Table 26. System Board Jumper settings

Jumper	Setting	Description
PWRD_EN	 1 2 3 (default)	The password feature is enabled (pins 1–2).
	 1 2 3	The password feature is disabled (pins 2–3).
NVRAM_CLR	 1 2 3 (default)	The configuration settings are retained at system boot (pins 2–3).
	 1 2 3	The configuration settings are cleared at the next system boot. (pins 1–2).

Related link

[Disabling a forgotten password](#)

System board connectors

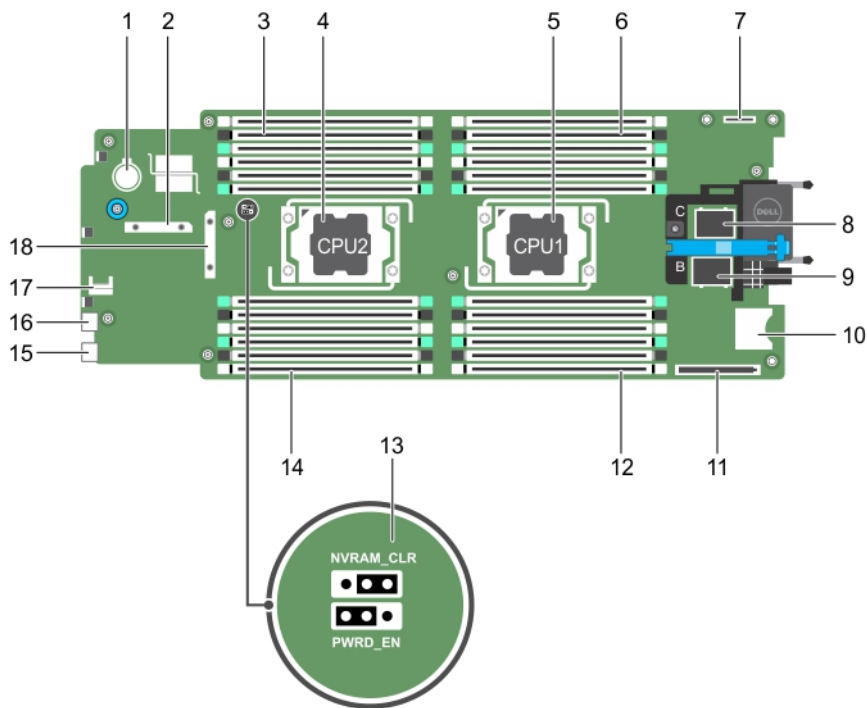

Figure 67. System board connectors

Table 27. System board connectors

Item	Connector	Description
1	BATTERY	Connector for the 3.0 V coin cell battery
2	STORAGE	Storage controller card connector
3	B3, B7, B11, B4, B8, B12	Memory module sockets (processor 2)
4	CPU2	Processor socket 2
5	CPU1	Processor socket 1
6	A1, A5, A9, A2, A6, A10	Memory module sockets (processor 1)
7	IDSDM/rSPI	IDSDM/rSPI card connector
8	MEZZ1_FAB_C	PCIe mezzanine card connector for the expansion bus
9	MEZZ2_FAB_B	PCIe mezzanine card connector for the expansion bus
10	VFLASH	SD vFlash card connector
11	bNDC	Network daughter card connector
12	A3, A7, A11, A4, A8, A12	Memory module sockets (processor 1)
13	PWRD_EN, NVRAM_CLR	System configuration jumpers

NOTE: Access needs removal of system board.

Item	Connector	Description
14	B1, B5, B9, B2, B6, B10	Memory module sockets (processor 2)
15	USB2	USB port
16	USB1	USB port
17	TPM	TPM connector
18	J_BP	Hard drive backplane connector

Disabling a forgotten password

The software security features of server module include a system password and a setup password. The password jumper enables these password features or disables them, and clears any password(s) currently in use.

Prerequisite

⚠ CAUTION: Many repairs may only be done by a certified service technician. You should only perform troubleshooting and simple repairs as authorized in your product documentation, or as directed by the online or telephone service and support team. Damage due to servicing that is not authorized by Dell is not covered by your warranty. Read and follow the safety instructions that came with the product.

Steps

- 1 Turn off the server module by using the operating system commands or the CMC.
- 2 Remove the server module from the enclosure to access the jumpers.
- 3 Move the jumper on the system-board jumper from pins 2 and 3 to pins 1 and 2.
- 4 Install the server module in the enclosure.
- 5 Turn on the server module.

When the server module is turned on, power indicator turns on to solid green. Allow the server module to finish booting.

The existing passwords are not disabled (erased) until the system boots with the password jumper on pins 2 and 3. However, before you assign a new system and/or setup password, you must reinstall the password jumper back to pins 1 and 2.

ⓘ NOTE: If you assign a new system and/or setup password with the jumper on pins 1 and 2, the system disables the new password(s) the next time it boots.

- 6 Turn off the server module by using the operating system commands or the CMC.
- 7 Remove the server module from the enclosure to access the jumpers.
- 8 Move the jumper on the system-board jumper from pins 1 and 2 to pins 2 and 3.
- 9 Install the server module in the enclosure.
- 10 Turn on the server module.
- 11 Assign a new system and/or setup password.

Troubleshooting your system

Safety first — for you and your system

⚠ CAUTION: Many repairs may only be done by a certified service technician. You should only perform troubleshooting and simple repairs as authorized in your product documentation, or as directed by the online or telephone service and support team. Damage due to servicing that is not authorized by Dell is not covered by your warranty. Read and follow the safety instructions that are shipped with your product.

ℹ NOTE: Solution validation was performed by using the factory shipped hardware configuration.

ℹ NOTE: For troubleshooting information about the PowerEdge VRTX enclosure components, see *Dell PowerEdge VRTX Enclosure Owner's Manual* at Dell.com/poweredgemanuals.

ℹ NOTE: This chapter provides troubleshooting information for the VRTX enclosure only. For troubleshooting information on the server modules, see the server module documentation at Dell.com/poweredgemanuals.

Topics:

- [Troubleshooting system memory](#)
- [Troubleshooting hard drives](#)
- [Troubleshooting Solid State Drives](#)
- [Troubleshooting USB devices](#)
- [Troubleshooting an Internal SD Card](#)
- [Troubleshooting processors](#)
- [Troubleshooting the system board](#)
- [Troubleshooting the NVRAM backup battery](#)

Troubleshooting system memory

Prerequisites

⚠ CAUTION: Many repairs may only be done by a certified service technician. You should only perform troubleshooting and simple repairs as authorized in your product documentation, or as directed by the online or telephone service and support team. Damage due to servicing that is not authorized by Dell is not covered by your warranty. Read and follow the safety instructions that are shipped with your product.

ℹ NOTE: Before performing the following procedure, ensure that you have installed the memory modules according to the memory installation guidelines for the server module.

Steps

- 1 Restart the server module:
 - a Press the power button after to turn off the server module.
 - b Press the power button again to apply power to the server module.
 If no error messages appear, go to step 8.
- 2 Enter the System Setup and check the system memory setting.
If the amount of memory installed matches the system memory setting, go to step 8.
- 3 Remove the server module from the enclosure.
- 4 Open the server module.

CAUTION: The memory modules are hot to touch for some time after the server module has been powered down. Allow time for the memory modules to cool before handling them. Handle the memory modules by the card edges and avoid touching the components.

- 5 Reseat the memory modules in their sockets.
- 6 Close the server module.
- 7 Install the server module in the enclosure.
- 8 Run the appropriate diagnostic test. For more information, see the Using system diagnostics section.
If the test fails, see the Getting help section.

Related links

- [Getting help](#)
- [Using system diagnostics](#)
- [Removing a server module](#)
- [Removing the system cover](#)
- [Installing the system cover](#)
- [Installing a server module](#)

Troubleshooting hard drives

Prerequisites

- CAUTION:** Many repairs may only be done by a certified service technician. You should only perform troubleshooting and simple repairs as authorized in your product documentation, or as directed by the online or telephone service and support team. Damage due to servicing that is not authorized by Dell is not covered by your warranty. Read and follow the safety instructions that are shipped with your product.
- CAUTION:** This troubleshooting procedure can destroy data stored on the hard drive. Before you proceed, back up all the files on the hard drive, if possible.

Steps

- 1 Run the appropriate controllers test and the hard drive tests in system diagnostics.
If the tests fail, go to step 3.
- 2 Take the hard drive offline and wait until the hard drive indicator codes on the drive carrier signal that the drive may be removed safely, then remove and reseat the drive carrier in the server module.
- 3 Restart the server module, enter the System Setup and confirm that the drive controller is enabled.
- 4 Ensure that any required device drivers are installed and are configured correctly.

NOTE: Installing a hard drive into another bay may break the mirror if the mirror state is optimal.

- 5 Remove the hard drive and install it in the other drive bay.
- 6 If the problem is resolved, reinstall the hard drive in the original bay.
If the hard drive functions properly in the original bay, the drive carrier could have intermittent problems. Replace the drive carrier.
- 7 If the hard drive is the boot drive, ensure that the drive is configured and connected properly.
- 8 Partition and logically format the hard drive.
- 9 If possible, restore the files to the drive.
If the problem persists, see the Getting help section.

Related links

- [Getting help](#)
- [Hard drive or SSD indicator patterns](#)
- [Removing a hard drive or SSD](#)
- [Installing a hard drive or SSD](#)

Troubleshooting Solid State Drives

Prerequisites

⚠ CAUTION: Many repairs may only be done by a certified service technician. You should only perform troubleshooting and simple repairs as authorized in your product documentation, or as directed by the online or telephone service and support team. Damage due to servicing that is not authorized by Dell is not covered by your warranty. Read and follow the safety instructions that are shipped with your product.

⚠ CAUTION: This troubleshooting procedure can destroy data stored on the SSD. Before you proceed, back up all the files on the SSD, if possible.

Steps

- 1 Run the appropriate tests in system diagnostics.
If the tests fail, go to step 3.
- 2 Take the SSD offline and wait until the indicator codes on the SSD carrier signal that the SSD may be removed safely, then remove and reseat the SSD carrier in the server module.
- 3 Restart the server module, enter the System Setup and confirm that the drive controller is enabled.
- 4 Ensure that any required device drivers are installed and are configured correctly.

📌 NOTE: Installing a SSD into another bay may break the mirror if the mirror state is optimal.

- 5 Remove the SSD and install it in the other SSD slot.
- 6 If the problem is resolved, reinstall the SSD in the original slot.
If the SSD functions properly in the original slot, the SSD carrier could have intermittent problems. Replace the SSD carrier.
- 7 If the SSD is the boot drive, ensure that the SSD is configured and connected properly.
- 8 Partition and logically format the SSD.
- 9 If possible, restore the files to the SSD.
If the problem persists, see the Getting help section.

Related links

[Getting help](#)

[Hard drive or SSD indicator patterns](#)

[Removing a hard drive or SSD](#)

[Installing a hard drive or SSD](#)

Troubleshooting USB devices

Prerequisite

⚠ CAUTION: Many repairs may only be done by a certified service technician. You should only perform troubleshooting and simple repairs as authorized in your product documentation, or as directed by the online or telephone service and support team. Damage due to servicing that is not authorized by Dell is not covered by your warranty. Read and follow the safety instructions that are shipped with your product.

Steps

- 1 Ensure that the server module is turned on.
- 2 Check the USB device connection to the server module.
- 3 Swap the USB device with a working USB device.
- 4 Connect the USB devices to the server module by using a powered USB hub.
- 5 If another server module is installed, connect the USB device to that server module. If the USB device works with a different server module, the first server module's USB ports may be faulty. See the Getting help section.

Related link

[Getting help](#)

Troubleshooting an Internal SD Card

Prerequisite

CAUTION: Many repairs may only be done by a certified service technician. You should only perform troubleshooting and simple repairs as authorized in your product documentation, or as directed by the online or telephone service and support team. Damage due to servicing that is not authorized by Dell is not covered by your warranty. Read and follow the safety instructions that are shipped with your product.

Steps

- 1 Enter the System Setup and ensure that the **Internal SD Card Port** is enabled.
- 2 Note the **Internal SD Card Redundancy** option enabled in the **Integrated Devices** screen of the System Setup (Mirror or Disabled).
- 3 Remove the server module from the enclosure.
- 4 If the **Internal SD Card Redundancy** option in the **Integrated Devices** screen of the System Setup is set to Mirror mode and SD card 1 has failed:
 - a Remove the SD card from SD card slot 1.
 - b Remove the SD card present in SD card slot 2 and insert it into SD card slot 1.
 - c Install a new SD card in slot 2.
- 5 If the **Internal SD Card Redundancy** option in the **Integrated Devices** screen of the System Setup is set to Mirror mode and SD card 2 has failed, insert the new SD card into SD card slot 2.
- 6 If the **Internal SD Card Redundancy** option in **Integrated Devices** screen of the System Setup is set to Disabled, replace the failed SD card with a new SD card.
- 7 Install the server module in the enclosure.
- 8 Enter the System Setup and ensure that the **Internal SD Card Port** option is enabled and **Internal SD Card Redundancy** option is set to Mirror mode.
- 9 Check if the SD card is functioning properly.
If the problem persists, see the Getting help section.

Related links

- [Getting help](#)
- [Removing a hard drive or SSD](#)
- [Removing a server module](#)
- [Installing a server module](#)

Troubleshooting processors

- 1 Remove the server module from the enclosure.
- 2 Open the server module.
- 3 Ensure that the processor(s) and heat sink(s) are properly installed.
- 4 If your system only has one processor installed, ensure that it is installed in the primary processor socket (CPU1).
- 5 Close the server module.
- 6 Install the server module in the enclosure.
- 7 Run the appropriate diagnostic test. For more information, see the Using system diagnostics section.
If the problem persists, see the Getting help section.

Related links

- [Getting help](#)
- [Removing a server module](#)
- [Installing a server module](#)

Troubleshooting the system board

Prerequisite

⚠ CAUTION: Many repairs may only be done by a certified service technician. You should only perform troubleshooting and simple repairs as authorized in your product documentation, or as directed by the online or telephone service and support team. Damage due to servicing that is not authorized by Dell is not covered by your warranty. Read and follow the safety instructions that are shipped with your product.

Steps

- 1 Remove the server module from the enclosure.
- 2 Open the server module.
- 3 Clear the server module NVRAM.
- 4 If there is a still a problem with the server module, remove and reinstall the server module in the enclosure.
- 5 Turn on the server module.
- 6 Run the appropriate diagnostic test. For more information, see the Using system diagnostics section.
If the tests fail, see the Getting help section.

Related links

[Getting help](#)

[Using system diagnostics](#)

[Removing a server module](#)

[Installing a server module](#)

Troubleshooting the NVRAM backup battery

Prerequisites

⚠ CAUTION: Many repairs may only be done by a certified service technician. You should only perform troubleshooting and simple repairs as authorized in your product documentation, or as directed by the online or telephone service and support team. Damage due to servicing that is not authorized by Dell is not covered by your warranty. Read and follow the safety instructions that are shipped with your product.

The battery maintains the server module configuration, date, and time information in the NVRAM when the server module is turned off. You may need to replace the battery if an incorrect time or date is displayed during the boot routine.

You can operate the server module without a battery; however, the server module configuration information maintained by the battery in NVRAM is erased each time you remove power from the server module. Therefore, you must reenter the system configuration information and reset the options each time the server module boots until you replace the battery.

Steps

- 1 Reenter the time and date through the System Setup.
- 2 Remove the server module from the enclosure for at least one hour.
- 3 Install the server module in the enclosure.
- 4 Enter the System Setup.

If the date and time are not correct in the System Setup, replace the battery. If the problem is not resolved by replacing the battery, see the Getting help section.

① NOTE: If the server module is turned off for long periods of time (for weeks or months), the NVRAM may lose its system configuration information. This situation is caused by a defective battery.

① NOTE: Some software may cause the server module's time to speed up or slow down. If the server module operates normally except for the time maintained by the System Setup, the problem may be caused by a software rather than by a defective battery.

Related links

[Getting help](#)

[Removing a server module](#)

[Installing a server module](#)

[Replacing the NVRAM backup battery](#)

Getting help

Topics:

- [Contacting Dell](#)
- [Accessing system information by using QRL](#)

Contacting Dell

Dell provides several online and telephone-based support and service options. If you do not have an active internet connection, you can find contact information on your purchase invoice, packing slip, bill, or Dell product catalog. Availability varies by country and product, and some services may not be available in your area. To contact Dell for sales, technical assistance, or customer-service issues:

- 1 Go to **Dell.com/support**.
- 2 Select your country from the drop-down menu on the bottom right corner of the page.
- 3 For customized support:
 - a Enter your system Service Tag in the **Enter your Service Tag** field.
 - b Click **Submit**.The support page that lists the various support categories is displayed.
- 4 For general support:
 - a Select your product category.
 - b Select your product segment.
 - c Select your product.The support page that lists the various support categories is displayed.
- 5 For contact details of Dell Global Technical Support:
 - a Click [Global Technical Support](#).
 - b The **Technical Support** page is displayed with details to call, chat, or e-mail the Dell Global Technical Support team.

Accessing system information by using QRL

You can use the Quick Resource Locator (QRL) to get immediate access to the information about your system.

Prerequisite

Ensure that your smartphone or tablet has the QR code scanner installed.

The QRL includes the following information about your system:

About this task

- How-to videos
- Reference materials, including the Owner's Manual, LCD diagnostics, and mechanical overview
- Your system service tag to quickly access your specific hardware configuration and warranty information
- A direct link to Dell to contact technical assistance and sales teams

Steps

- 1 Go to **Dell.com/QRL** and navigate to your specific product or
- 2 Use your smartphone or tablet to scan the model-specific Quick Resource (QR) code on your Dell PowerEdge system or in the Quick Resource Locator section.

Quick Resource Locator for M630p



Figure 68. Quick Resource Locator for M630p