

Dell PowerEdge FX2 and FX2s Enclosure

Owner's Manual

Notes, cautions, and warnings

 **NOTE:** A NOTE indicates important information that helps you make better use of your product.

 **CAUTION:** A CAUTION indicates either potential damage to hardware or loss of data and tells you how to avoid the problem.

 **WARNING:** A WARNING indicates a potential for property damage, personal injury, or death.

1 About your Dell PowerEdge FX2/FX2s.....	6
Terms used in the document.....	6
Sled slot numbering.....	7
Front panel features and indicators—PowerEdge FX2/FX2s.....	8
Diagnostic indicators.....	9
Power button functions.....	10
KVM features.....	10
Back panel features and indicators—PowerEdge FX2s and FX2.....	11
Power supply unit indicators.....	12
I/O module indicators.....	13
CMC module.....	14
Cooling fan indicator codes.....	16
Configuration wizard.....	17
System messages.....	17
Documentation matrix.....	17
Accessing system information by using QRL.....	18
2 Initial system configuration.....	20
Before you begin.....	20
Setting up your PowerEdge FX2/FX2s.....	20
Logging in to the CMC.....	21
3 PowerEdge FX2/FX2s mapping configurations.....	22
LAN On Motherboard network.....	22
Supported I/O modules.....	22
I/O module port mapping—four-bay chassis.....	23
I/O module port mapping—eight-bay chassis.....	24
I/O module port mapping—six-bay chassis.....	24
I/O module port mapping—two-bay chassis.....	25
I/O module port mapping—three-bay chassis.....	26
I/O module and PCIe mezzanine card configuration guidelines.....	26
Configuring network settings for the I/O module.....	27
Expansion bus.....	27
PCIe expansion slot mapping	27
PCIe slot mapping from compute sleds.....	27
PCIe slot mapping from compute sleds mapped to storage sleds.....	29
Managing PCIe slots.....	31
Internal management network.....	31
4 Installing and removing PowerEdge FX2/FX2s enclosure components.....	32
Customer and field replaceable units—PowerEdge FX2/FX2s.....	32
Safety instructions.....	33
Before working inside your system.....	33
After working inside your system.....	33

Recommended tools.....	33
System cover.....	34
Removing the system cover.....	34
Installing the system cover.....	35
Sleds.....	35
Removing a compute sled.....	35
Installing a compute sled.....	36
Removing a storage sled.....	37
Installing a storage sled.....	39
Inside the system.....	40
CMC module.....	41
Removing the CMC module.....	42
Installing the CMC module.....	42
I/O module.....	44
Removing an I/O module.....	44
Installing an I/O module.....	44
PCIe module.....	45
Removing a PCIe module.....	45
Installing a PCIe module.....	46
Expansion cards.....	47
Expansion card types and form factor.....	47
Expansion card operational power status.....	47
PCIe module indicators.....	47
Removing an expansion card.....	48
Installing an expansion card.....	49
Power supply units.....	50
Removing a power supply unit.....	50
Installing a power supply unit.....	51
Cooling fans.....	52
Removing a cooling fan.....	52
Installing a cooling fan.....	53
Cooling-fan cage.....	54
Removing the cooling-fan cage.....	54
Installing the cooling-fan cage.....	55
PCIe switch board.....	56
Removing the PCIe switch board.....	56
Installing the PCIe switch board.....	57
Fan interface board.....	58
Removing the fan interface board.....	58
Installing the fan interface board.....	59
Interposer module.....	60
Removing the bottom interposer module.....	61
Installing the bottom interposer module.....	64
Removing the top interposer module.....	65
Installing the top interposer module.....	68
Midplane assembly.....	69
Removing the midplane assembly.....	69
Installing the midplane assembly.....	73
Power interposer board.....	74
Control panel.....	75

Removing the control panel.....	75
Installing the control panel.....	77
KVM panel.....	77
Removing the KVM panel.....	77
Installing the KVM panel.....	79
5 Troubleshooting your system.....	80
Responding to a systems management alert message.....	80
Troubleshooting external connections.....	80
Troubleshooting a damaged enclosure.....	80
Troubleshooting enclosure components.....	81
Troubleshooting a wet enclosure.....	81
Troubleshooting power supply units.....	81
Troubleshooting power supply unit mismatch.....	82
Troubleshooting cooling problems.....	82
Troubleshooting cooling fans.....	82
Troubleshooting expansion cards.....	83
Troubleshooting I/O modules.....	83
6 Technical specifications—PowerEdge FX2/FX2s.....	85
Dimensions and weight.....	85
Sled specifications.....	85
Power specifications.....	86
Chassis Management Controller (CMC) specifications.....	86
Enclosure control panel specifications.....	86
I/O module specifications.....	86
Environmental specifications.....	87
Expanded operating temperature.....	88
7 Getting help.....	90
Contacting Dell EMC.....	90
Locating service tag of your system.....	90
Accessing system information by using QRL.....	90

About your Dell PowerEdge FX2/FX2s

The Dell PowerEdge FX2/FX2s is a 2U enclosure that can support up to four half-width compute sleds, up to eight quarter-width compute sleds, up to two full-width compute sleds, or a mix of compute sled types. The PowerEdge FX2s enclosure also supports half-width storage sleds mapped to the compute sleds.

NOTE: For information on mapping configurations from storage sleds to compute sleds in the PowerEdge FX2s enclosure, see the *Dell PowerEdge FD332 Owner's Manual* at Dell.com/poweredgemanuals.

NOTE: PowerEdge FX2 does not support storage sleds.

For the enclosure and sleds to function as a system, you must install the sleds in the enclosure. Enclosure components such as power supply units, fan modules, Chassis Management Controller (CMC) module, KVM panel, and I/O modules for external network connectivity are shared resources of the sleds installed in the enclosure.

PowerEdge FX2s supports eight low-profile PCIe slots assigned to the compute sleds in the enclosure.

NOTE: PowerEdge FX2 does not support PCIe slots.

Topics:

- [Terms used in the document](#)
- [Sled slot numbering](#)
- [Front panel features and indicators—PowerEdge FX2/FX2s](#)
- [Back panel features and indicators—PowerEdge FX2s and FX2](#)
- [Cooling fan indicator codes](#)
- [Configuration wizard](#)
- [System messages](#)
- [Documentation matrix](#)
- [Accessing system information by using QRL](#)

Terms used in the document

The following table describes the terms used in this document.

Table 1. Terms used in the document

Term	Description
Enclosure, chassis, or system	Refers to the Dell PowerEdge FX2 or FX2s system.
Storage sled	Refers to the PowerEdge FD332 sled, which supports up to sixteen 2.5 inch hot-swap hard drives/SSDs in a drive drawer. NOTE: PowerEdge FX2 does not support the PowerEdge FD332 storage sled.
Compute sled	Refers to the half-width, quarter-width, or full-width servers, to which the storage sleds are mapped. NOTE: The PowerEdge FM120x4 half-width compute sled does not support the storage sled. NOTE: The PowerEdge FM120x4 half-width compute sled cannot be mixed with the other half-width, quarter-width, or full-width compute sleds. NOTE: For information on mapping of storage sleds to compute sleds in PowerEdge FX2s, see the <i>Dell PowerEdge FD332 Owner's Manual</i> at Dell.com/poweredgemanuals .

Table 1. Terms used in the document(continued)

Term	Description
Four-bay chassis	Refers to the PowerEdge FX2/FX2s enclosure configuration that supports up to four half-width compute sleds. <i>i</i> NOTE: In PowerEdge FX2s, the four-bay chassis configuration supports a combination of half-width compute and storage sleds. It supports a maximum of three storage sleds mapped to a compute sled.
Eight-bay chassis	Refers to the PowerEdge FX2/FX2s enclosure configuration that supports up to eight quarter-width compute sleds.
Two-bay chassis	Refers to the PowerEdge FX2/FX2s enclosure configuration that supports up to supports two full-width compute sleds.
Three-bay chassis	Refers to the PowerEdge FX2/FX2s enclosure configuration that supports one full-width compute sled and up to two half-width compute sleds. <i>i</i> NOTE: In PowerEdge FX2s, this configuration also supports up to two half-width storage sleds mapped to one full-width compute sled.
Six-bay chassis	Refers to the PowerEdge FX2/FX2s enclosure configuration that supports up to four quarter-width compute sleds and up to two half-width compute sleds. <i>i</i> NOTE: In PowerEdge FX2s, this configuration also supports up to two half-width storage sleds mapped to up to four quarter-width compute sleds.
I/O module	Refers to an Ethernet pass-through module or switch module installed in the enclosure.
Expansion card	Refers to low-profile PCIe cards installed in the enclosure that provide I/O expansion.
Warm swap	A slot is considered warm-swap if the sled associated with a component in that slot must be turned off before adding or replacing the component. However, the enclosure and the rest of the sleds remain powered on.
Hot swap	A component in the enclosure is considered as hot swap if it can be replaced or installed while the enclosure and sleds are powered on.

Sled slot numbering



Figure 1. Sled slot numbering—four-bay chassis

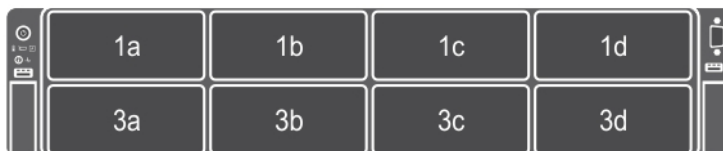

Figure 2. Sled slot numbering—eight-bay chassis

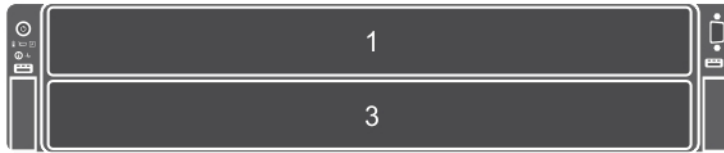

Figure 3. Sled slot numbering—two-bay chassis



Figure 4. Sled slot numbering — six-bay chassis



Figure 5. Sled slot numbering—three-bay chassis

Front panel features and indicators—PowerEdge FX2/FX2s

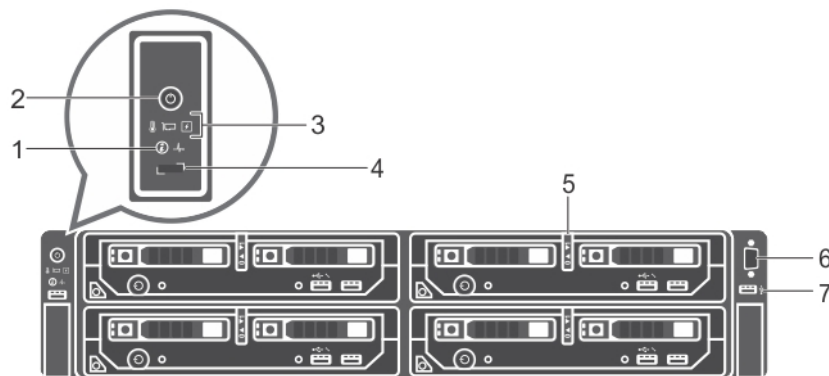





Figure 6. Front panel features and indicators—PowerEdge FX2/FX2s

Table 2. Front panel features and indicators—PowerEdge FX2/FX2s

Item	Indicator, Button, or Connector	Icon	Description
1	System identification button		The identification buttons on the front and back panels can be used to locate a particular system within a rack. When one of these buttons is pressed, the system status indicator on the back flashes until one of the buttons is pressed again. Press to toggle the system ID on and off.
2	Enclosure power-on indicator, power button		The power-on indicator turns on when the enclosure power is on. The power button controls the power supply output to the system. For more information, see Power Button Functions .
3	Diagnostic indicators		The diagnostic indicators turns on to display error status. For more information, see Diagnostic Indicators .
4	KVM select button		Enables you to map the KVM to the sleds.
5	Sleds		PowerEdge FX2/FX2s supports up to: <ul style="list-style-type: none"> • four half-width compute sleds, or • eight quarter-width compute sleds, or • two full-width compute sleds, or • four quarter-width compute sleds and two half-width compute sleds, or • one full-width compute sled and up to two half-width compute sleds <p>i NOTE: PowerEdge FX2s supports a combination of compute and storage sleds. For information on mapping of storage sleds to compute sleds in PowerEdge FX2s, see the <i>Dell PowerEdge FD332 Owner's Manual</i> at Dell.com/poweredgemanuals.</p>
6	Video connector		Enables you to connect a monitor to the system.
7	USB connector		Enables you to connect a keyboard or mouse to the system.

Diagnostic indicators

The diagnostic indicators on the system front panel display error status during system startup.

i NOTE: No diagnostic indicators are lit when the system is switched off. To start the system, plug it into a working power source and press the power button.

The following table describes the system conditions and possible corrective actions associated with the diagnostic indicators.

Table 3. Diagnostic indicators





	Health indicator	
	Condition	Corrective Action
	If the system is on, and in good health, the indicator lights solid blue.	None required.
	The indicator blinks amber if the system is on or in standby, and any error exists (for example, a failed fan or hard drive)	See the CMC Log or system messages for the specific issue.
	Electrical indicator	

Table 3. Diagnostic indicators(continued)

	Health indicator	
	Condition	Corrective Action
	The indicator blinks amber if the system experiences an electrical error (for example, voltage out of range, or a failed power supply or voltage regulator).	See the CMC Chassis Log or system messages for the specific issue. If it is due to a problem with the power supply, check the LED on the power supply. Reseat the power supply by removing and reinstalling it. If the problem persists, see Getting Help .
	Temperature indicator	
	Condition	Corrective Action
	The indicator blinks amber if the system experiences a thermal error (for example, a temperature out of range or fan failure).	Ensure that none of the following conditions exist: <ul style="list-style-type: none"> • A cooling fan is removed or has failed. • The system cover, cooling shroud, EMI filler panel, memory-module blank, or back-filler bracket is removed. • Ambient temperature is too high. • External airflow is obstructed. See Getting Help .
	PCIe indicator	
	Condition	Corrective Action
	The indicator blinks amber if a PCIe card experiences an error.	Restart the sled. Update any required drivers for the PCIe card. Reinstall the card. If the problem persists, see Getting Help .

Power button functions

The following section describes the different functions of the power button on your PowerEdge FX2/FX2s enclosure.

Chassis power button and chassis power button LED

The chassis power button is used to control power to the chassis and the sleds. The chassis power button LED indicates the status of power to the chassis and the sleds:

- If the LED is OFF, power to the chassis and the sleds is turned off.
- If the LED is ON, power to the chassis and the sleds is turned on.

Powering on the chassis and sleds

Press the chassis power button and the chassis power button LED changes from OFF to ON. If pressing the chassis power button does not change the power button LED from OFF to ON, see the troubleshooting section.

Powering off the chassis and sleds

For a graceful shutdown of all the sleds and the chassis, press and hold the chassis power button for 4 to 10 seconds and release it.

NOTE: Depending on the status of the sleds, graceful shutdown may not be possible. You may opt for a forced shutdown by pressing and holding the chassis power button for more than 10 seconds.

KVM features

- Local KVM access can be remotely disabled on the enclosure by using the CMC interface.
- One VGA connector—The KVM supports a video display resolution range from 640 × 480 at 60 Hz up to 1280 × 1024 × 65,000 colors (non-interlaced) at 75 Hz.
- One USB port for keyboard or mouse.
- KVM provides access to the compute sleds. You can access one compute sled at a time by using the KVM select button.

Back panel features and indicators—PowerEdge FX2s and FX2

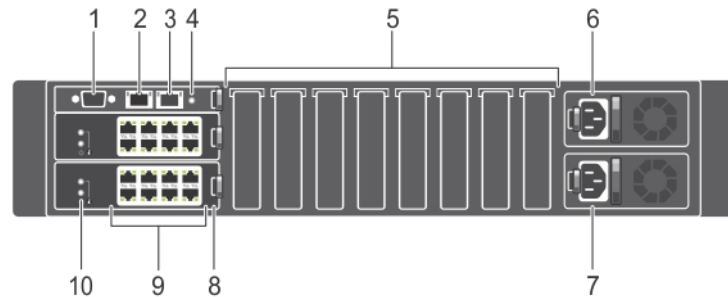

Figure 7. Back panel features and indicators—PowerEdge FX2s

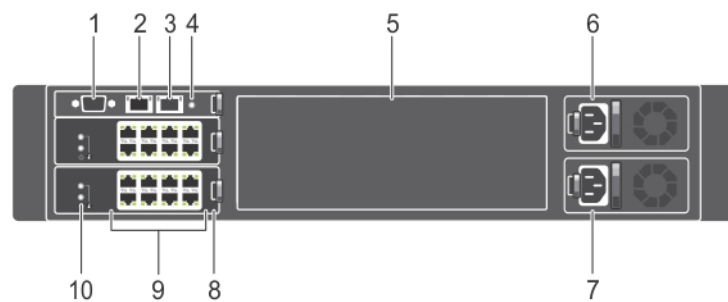

Figure 8. Back panel features and indicators—PowerEdge FX2

Table 4. Back panel features and indicators—PowerEdge FX2 and PowerEdge FX2s enclosures

Item	Indicator, Button, or Connector	Description
1	Serial connector	DB-9 serial connector for CMC configuration.
2	Ethernet connector Gb1	Connects the network cable from the management system to the CMC.
3	Ethernet connector STK/Gb2 (stack)	Used for daisy-chaining CMCs in separate enclosures. i NOTE: This port can also be used for CMC NIC failover.
4	System identification button	The identification buttons on the front and back panels can be used to locate a particular system within a rack. When one of these buttons is pressed, the system status indicator on the back flashes until one of the buttons is pressed again. Press to toggle the system ID on and off.
5	Low-profile PCIe expansion slots (8)	Enable you to connect up to eight low-profile PCIe expansion cards. i NOTE: PowerEdge FX2 does not support PCIe expansion slots and has a filler panel.
6	Power supply unit (PSU1)	1100 W (1050 W for low line)

Table 4. Back panel features and indicators—PowerEdge FX2 and PowerEdge FX2s enclosures(continued)

Item	Indicator, Button, or Connector	Description
		1600 W (800 W for low line) 2000 W (1000 W for low line) 2400 W (1400 W for low line)
7	Power supply unit (PSU2)	1100 W (1050 W for low line) 1600 W (800 W for low line) 2000 W (1000 W for low line) 2400 W (1400 W for low line)
8	I/O module (2)	Provides Ethernet connectivity to the compute sleds in the enclosure.
9	I/O module ports	Network interface for I/O modules.
10	I/O module indicators	Two indicators for: <ul style="list-style-type: none"> • Status • Power

Power supply unit indicators

Each AC power supply unit (PSU) has an illuminated translucent handle that serves as an indicator to show whether power is present or whether a power fault has occurred. The AC PSUs must be connected to a Power Distribution Unit (PDU) or to an electrical outlet.

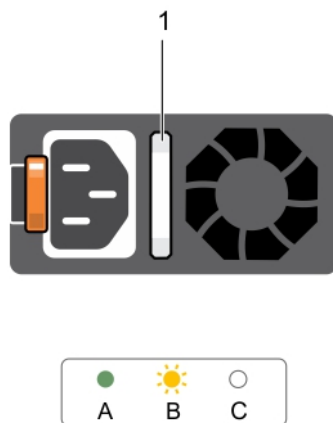

Figure 9. PSU indicators

1. AC PSU status indicator/handle

NOTE: The 2000 W PSU power cable connector is different from the connector shown in the image above.

The PSU indicators provide the following information:

Table 5. PSU indicators

Convention	Power indicator pattern	Condition
A	Green	In standby mode, the handle lights green indicating that a valid power source is connected to the PSU and that the PSU is operational.
B	Flashing amber	Indicates a problem with the PSU. CAUTION: When correcting a PSU mismatch, replace only the PSU with the flashing indicator. Swapping the opposite PSU to make a matched pair can result in an error condition and unexpected system shutdown. To change from a High

Table 5. PSU indicators(continued)

Convention	Power indicator pattern	Condition
		<p>Output configuration to a Low Output configuration or vice versa, you must power down the system.</p> <p>CAUTION: AC power supplies support both 220 V and 110 V input voltages. When two identical power supplies receive different input voltages, they can output different wattages, and trigger a mismatch.</p> <p>CAUTION: All power supplies used must be of the same type and have the same maximum output power.</p> <p>NOTE: The FX2 chassis supports only PSUs with a rated capacity of 1100 W, 1600 W, 2000 W, or 2400 W.</p>
	Flashing green and turns off	When hot-adding a PSU, the PSU handle flashes green five times then turns off. This indicates a PSU mismatch.
C	Not lit	Power is not connected.

I/O module indicators

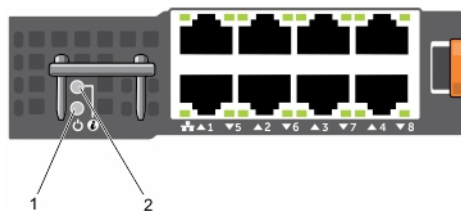

Figure 10. I/O module indicators (pass-through module)

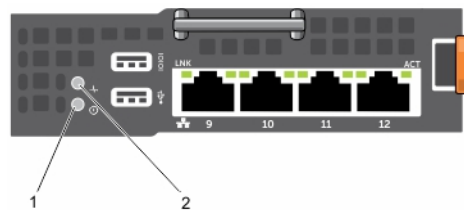

Figure 11. I/O module indicators (switch module)

1. power indicator
2. status indicator

The indicators provide the following information:

Power indicator pattern	Description
Green	The I/O module is operating normally.
Off	The I/O module is powered off.
Status indicator pattern	Description
Blue	The I/O module is operating normally.

Status indicator pattern	Description
Blinking Blue	The CMC is identifying the I/O module.
Blinking Amber	The I/O module is in a fault condition.
Off	The I/O module is powered off, or booting is in progress.

For more information, see the I/O module documentation at Dell.com/poweredgemanuals.

CMC module

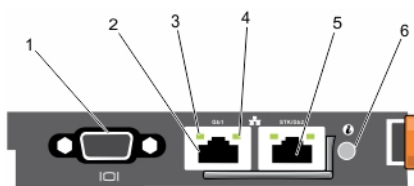

Figure 12. CMC module

- | | |
|--|---------------------------------|
| 1. DB-9 serial connector for local configuration | 2. Ethernet connector Gb1 |
| 3. link indicator | 4. activity indicator |
| 5. Ethernet connector STK/Gb2 (stack) | 6. system identification button |

NOTE: This port can also be used for CMC NIC failover.

CMC indicators

The CMC indicators on the back panel of the enclosure provide the following information:

Indicator	Description				
System identification button	The identification buttons on the front and back panels can be used to locate a particular system within a rack. When one of these buttons is pressed, the system status indicator on the back flashes until one of the buttons is pressed again. Press to toggle the system ID on and off.				
Status indicator	<table border="0"> <tbody> <tr> <td>Blue</td> <td>The CMC is active and operating normally.</td> </tr> <tr> <td>Amber</td> <td>The chassis is in fault condition.</td> </tr> </tbody> </table>	Blue	The CMC is active and operating normally.	Amber	The chassis is in fault condition.
Blue	The CMC is active and operating normally.				
Amber	The chassis is in fault condition.				

CMC features

The CMC provides the following multiple systems management functions:

- Enclosure-level real-time automatic power and thermal management:
 - Monitors system power requirements.
 - Reports real-time power consumption, which includes logging high and low points with a time stamp.
 - Supports setting an optional enclosure Maximum Power Limit, which either alerts or takes actions, such as throttling compute sleds and/or preventing the power up of new compute sleds to keep the enclosure under the defined maximum power limit.
 - Monitors and automatically controls cooling fans based on actual ambient and internal temperature measurements.
 - Provides comprehensive enclosure inventory and status or error reporting.
 - Centralized configuration of the following:
 - The enclosure's network and security settings.
 - Power redundancy and power ceiling settings.
- NOTE:** Modifying the modular enclosure redundancy policy is recommended to be performed while the modular enclosure is powered off.
- I/O module and iDRAC network settings.

- First boot device on the compute sleds.
- Checks I/O path consistency for the I/O module, PCIe slots, and sleds and disables components if necessary to protect the system hardware.
- User access security.

The CMC module is hot-swappable. During the period that the CMC module is removed:

- you cannot turn on newly installed compute sleds
- existing compute sleds cannot be accessed remotely
- enclosure cooling fans run at maximum speed for thermal protection of the components

Daisy-chain CMC network connection

The CMC has two RJ-45 Ethernet ports, labeled Gb1 (the uplink port) and STK/Gb2 (the stacking or cable consolidation port). With basic cabling, you can connect the Gb port to the management network and leave the STK/Gb2 port unused.

CAUTION: Connecting the STK/Gb2 port to the management network will have unpredictable results if the CMC setting is not changed from default Stacking to Redundant, to implement NIC failover. In the default Stacking mode, cabling the Gb1 and STK/Gb2 ports to the same network (broadcast domain) can cause a broadcast storm. A broadcast storm can also occur if the CMC setting is changed to Redundant mode, but the cabling is daisy chained between chassis in the Stacking mode. Ensure that the cabling model matches the CMC setting for the intended usage.

NOTE: The STK/Gb2 port can also be used for CMC NIC failover. Ensure that the CMC setting is changed from default Stacking to Redundant to implement NIC failover.

If you have multiple chassis in a rack, you can reduce the number of connections to the management network by daisy-chaining up to four chassis together. This reduces the connections required from four to one.

When daisy-chaining chassis together, Gb1 is the uplink port and STK/Gb2 is the stacking (cable consolidation) port. Connect the Gb ports to the management network or to the STK port of the CMC in a chassis that is closer to the network. You must connect the STK port only to a Gb port that is further from the chain or network.

NOTE: The CMC must be installed for the system to power on. See the PowerEdge FX2/FX2s CMC User's Guide at Dell.com/poweredgemanuals for complete instructions on setting up and operating the CMC module.

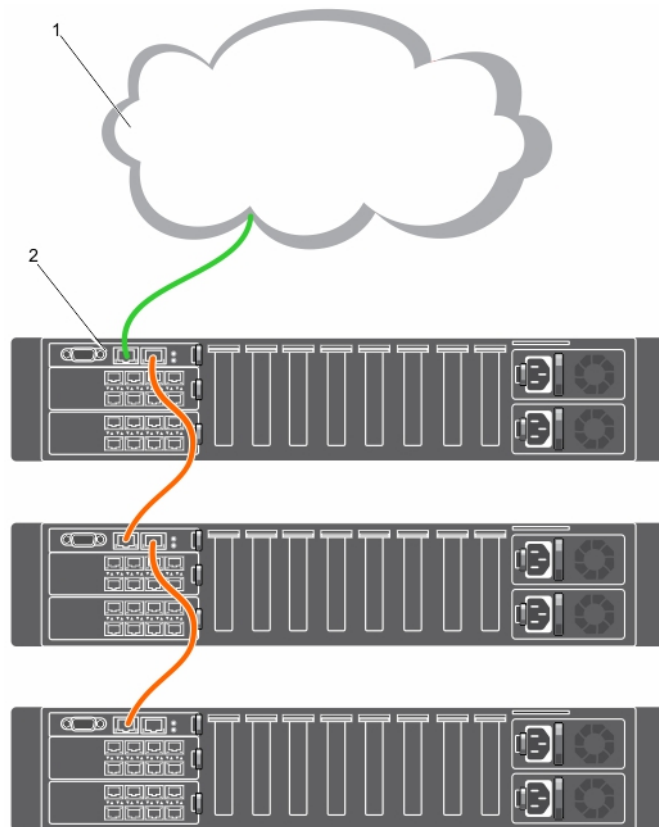

Figure 13. CMC daisy-chaining

1. management network
2. CMC

Cooling fan indicator codes

Each cooling fan has an LED that indicates the power status of the cooling fan.

Indicator Pattern	Condition
Not lit	Cooling fan is functioning correctly.
Flashing Amber	Indicates a problem with the cooling fan.

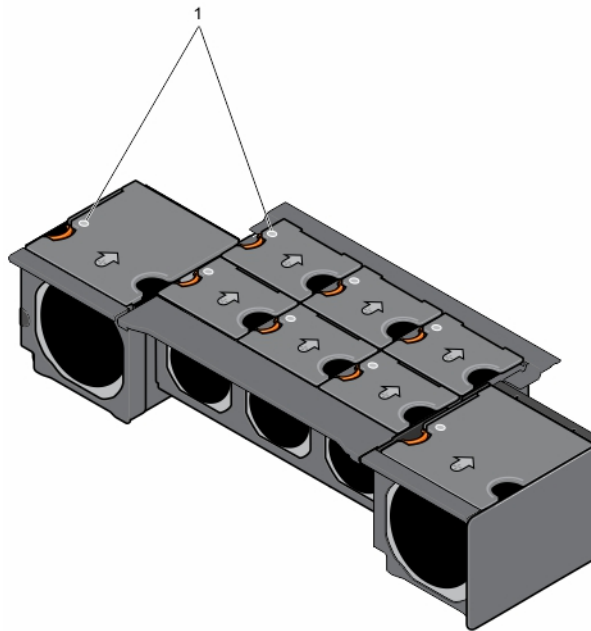

Figure 14. Cooling fan indicators

1. status indicator

Configuration wizard

The Chassis Management Controller (CMC) is pre-configured to use a static IP address. To use Dynamic Host Configuration Protocol (DHCP):

1. Access the Chassis Management Controller (CMC).
2. Click **Network**.
3. Click **IPv4** or **IPv6**.
4. Select **DHCP Enable**.

For more information, see the Dell PowerEdge FX2/FX2s CMC User's Guide at Dell.com/esmmanuals.

System messages

The CMC web interface displays system messages to notify you of possible problems related to the enclosure and to the sleds in the enclosure. For a detailed listing of these error messages, including possible causes and solutions, see the Dell Event and Error Messages Reference Guide at Dell.com/openmanagemanuals → **OpenManage software**.

Documentation matrix

The documentation matrix provides information about documents that you can refer to, for setting up and managing your system.

Table 6. Documentation matrix

To...	See...
Install your system into a rack	Rack documentation included with your rack solution
Set up your system and know the technical specifications of your system	Getting Started Guide
Install the operating system	Operating system documentation at Dell.com/operatingsystemmanuals
Get an overview of the Dell Systems Management offerings	Dell OpenManage Systems Management Overview Guide at Dell.com/openmanagemanuals

Table 6. Documentation matrix(continued)

To...	See...
Install, configure, and use the Chassis Management Controller (CMC)	Dell PowerEdge FX2/FX2s CMC User's Guide at Dell.com/esmmanuals
Know about the RACADM subcommands and supported RACADM interfaces	RACADM Command Line Reference Guide for iDRAC and CMC at Dell.com/esmmanuals
Launch, enable and disable Lifecycle Controller, know the features, use and troubleshoot Lifecycle Controller	Dell Lifecycle Controller User's Guide at Dell.com/openmanagemanuals → OpenManage software
Use Lifecycle Controller Remote Services	Dell Lifecycle Controller Remote Services Quick Start Guide at Dell.com/esmmanuals
Set up, use, and troubleshoot OpenManage Server Administrator	Dell OpenManage Server Administrator User's Guide at Dell.com/openmanagemanuals
Install, use and troubleshoot OpenManage Essentials	Dell OpenManage Essentials User's Guide at Dell.com/openmanagemanuals
Know the system features, remove and install system components, and troubleshoot components	Owner's Manual at Dell.com/poweredgemanuals
Know the compute sled features, remove and install compute sled components, troubleshoot compute sled components	Compute sled Owner's Manual at Dell.com/poweredgemanuals
Know the storage sled features, storage sled to compute sled configuration options, remove and install storage sled components, and troubleshoot components	Storage sled Owner's Manual at Dell.com/poweredgemanuals
Configure and log in to iDRAC, set up managed and management system, know the iDRAC features and troubleshoot using iDRAC	Integrated Dell Remote Access Controller User's Guide at Dell.com/idracmanuals
Know about I/O module features, configure the I/O module and additional I/O module information	I/O module documentation at Dell.com/poweredgemanuals
Know the features of the storage controller cards, deploy the cards, and manage the storage subsystem	Storage controller documentation at Dell.com/storagecontrollermanuals
See the event and error messages generated by the system firmware and agents that monitor system components	Dell Event and Error Messages Reference Guide at Dell.com/openmanagemanuals → OpenManage software

Accessing system information by using QRL

You can use the Quick Resource Locator (QRL) to get immediate access to the information about your system.

Prerequisites

Ensure that your smartphone or tablet has the QR code scanner installed.

About this task

The QRL includes the following information about your system:

- How-to videos
- Reference materials, including the Owner's Manual, LCD diagnostics, and mechanical overview
- Your system service tag to quickly access your specific hardware configuration and warranty information
- A direct link to Dell to contact technical support and sales teams

Steps

1. Go to [Dell.com/QRL](https://www.dell.com/QRL) and navigate to your specific product or
2. Use your smartphone or tablet to scan the model-specific Quick Resource (QR) code located in the following image or on your Dell PowerEdge system:



Initial system configuration

Before you begin

CAUTION: The enclosure power supplies must be connected to a PDU or to an electrical outlet. The power supplies require a 100 V to 120 V or 200 V to 240 V power source. You can select only one AC power input, as the system does not operate at both ranges simultaneously.

- If applicable, update all PCIe card firmware and iDRAC firmware on the compute sled(s).
- Download the latest version of CMC firmware from **Dell.com/support**. Also, make sure that you have the *Dell Systems Management Tools and Documentation* DVD that was included with your system.
- If your network uses static addressing, you need the IP address, subnet mask, and gateway to configure the CMC and other sleds in the enclosure.

Setting up your PowerEdge FX2/FX2s

Steps

1. Unpack the enclosure and sled(s), and identify each item.

For more information, see the *Dell PowerEdge FX2 Getting Started With Your System and Rack Installation Guide* at **Dell.com/poweredgemanuals**.

NOTE: Whenever you need to lift the system, get others to assist you. To avoid injury, do not attempt to lift the system by yourself.

CAUTION: To reduce chassis weight while installing the enclosure in the rack, remove the power supply units (PSUs) and sleds before lifting the enclosure. Note the number of each sled and temporarily label them before removal, so that you can replace them in their original locations.

2. Install the enclosure in the rack.
3. Install the sled(s) and PSUs.

CAUTION: Do not turn on the compute sled(s) until you have configured the I/O module.

4. Connect the network cable to the I/O modules to provide network connection to the compute sleds.
5. Connect the PSUs to a power distribution unit (PDU) or electrical outlet by using the power cables.
6. Optionally, connect the video and keyboard/mouse to the enclosure.
7. Press the power button on the enclosure front panel to turn on the enclosure.
8. Configure the Chassis Management Controller (CMC) by using the CMC web interface and the RACADM command line interface (CLI).

NOTE: For a detailed description on configuring the CMC settings, see the *PowerEdge FX2/FX2s CMC User's Guide* at **Dell.com/esmmanuals**.

9. Perform either of the following tasks to obtain a CMC IP address by using DHCP:
 - Connect a serial cable to the serial DB9 connector on the CMC module. Log in by using the default credentials and use RACADM commands to retrieve the CMC IP address.
 - Connect to one of the compute sleds and boot to the Human Interface Infrastructure (HII) browser to retrieve the CMC IP address.

10. Connect to the CMC IP address through the Web browser by using the default logon credentials.

NOTE: The default IP address of the CMC is 192.168.0.120. The default user name is `root` and password is `calvin`.

11. Provide each iDRAC with an IP address in the CMC Web interface.
12. Connect to each iDRAC by using a Web browser and type the final configuration of iDRAC.

The default user name is **root** and password is **calvin**.

13. Turn on the compute sleds and install the operating system.

Next steps

To see step-by-step instructions for unpacking and installing the enclosure, scan the following Quick Resource code. For more information about the Quick Resource Locator, see [Accessing system information by using QRL](#) on page 18.



Figure 15. Quick Resource Locator for installing the enclosure

Logging in to the CMC

You can perform the initial network configuration of the chassis management controller (CMC) either before or after the CMC has an IP address.

You can log in to the CMC as a CMC local user, as a Microsoft Active Directory user, or as an LDAP user. You can also log in by using the Single Sign-On or Smart Card.

For more information on managing the system and configuring the settings, see the Dell PowerEdge FX2/FX2s CMC User's Guide at Dell.com/esmanuals.

PowerEdge FX2/FX2s mapping configurations

This section provides the following information on the connectivity of the compute sleds to the I/O module(s), PCIe slots, and Chassis Management Controller (CMC) of the enclosure:

- LAN On Motherboard network and compute sled to I/O module port mapping configurations
- Expansion Bus and compute sled to PCIe expansion slot mapping configurations
- Internal management network

NOTE: The I/O module port mapping and PCIe slot mapping from compute sleds are pre-configured.

Topics:

- [LAN On Motherboard network](#)
- [I/O module and PCIe mezzanine card configuration guidelines](#)
- [Configuring network settings for the I/O module](#)
- [Expansion bus](#)
- [Internal management network](#)

LAN On Motherboard network

LAN On Motherboard (LOM) network refers to the Ethernet connectivity provided to the compute sleds by the I/O modules installed at the back of the PowerEdge FX2/FX2s enclosure.

LOM network provides four connections per half-width compute sled, two connections per quarter-width compute sled, and eight connections per full-width compute sled for a maximum of 16 lanes. The maximum external connections possible are 16 RJ-45 Ethernet ports.

Supported I/O modules

The enclosure supports up to two switches or pass-through modules. The maximum width for an Ethernet pass-through module is eight lanes.

The following I/O modules are supported on the enclosure:

- Dell PowerEdge FN 410S I/O Module
- Dell PowerEdge FN 410T I/O Module
- Dell PowerEdge FN2210S I/O Module
- PowerEdge FX2 and FX2s 1 Gb x8 RJ45 pass-through module
- PowerEdge FX2 and FX2s 10 Gb x8 SFP+ pass-through module
 - The 10 Gb pass-through module supports both 10 GbE SFP+ and 1 GbE SFP optical module. The 10 Gb pass-through module supports 1 Gb and 10 Gb connections.
 - Use SFP+ to configure 10 Gb pass-through module and SFP or 1 Gb TOR switch to configure 1 Gb pass-through module.
 - Using a dual-rate optical module for a 1 GbE connection on the 10 Gb pass-through module results in an invalid link.
 - Use a dual-rate SFP+ optical module to configure a 10 GbE connection.
 - To establish optical links between two 10 Gb pass-through modules, an external rack switch must be used as an intermediary. Direct optical connection (using SFP modules, SFP+ modules, and Directed Attach Copper cables) between two 10 Gb pass-through modules is not supported.

NOTE: This restriction is not applicable for Direct Attach Copper connections or to the 1 Gb pass-through module.

NOTE: For more information on the I/O modules, see the I/O module documentation at Dell.com/poweredge manuals.

I/O module port mapping—four-bay chassis

The following I/O module port mapping options are available on the four-bay chassis configuration that supports up to four half-width compute sleds.

NOTE: In the four-bay PowerEdge FX2s configurations that support storage sleds mapped to compute sled(s), the I/O module ports are mapped only to the compute sled(s). If storage sleds are installed, the corresponding ports on the I/O modules mapping to these slots are not active.

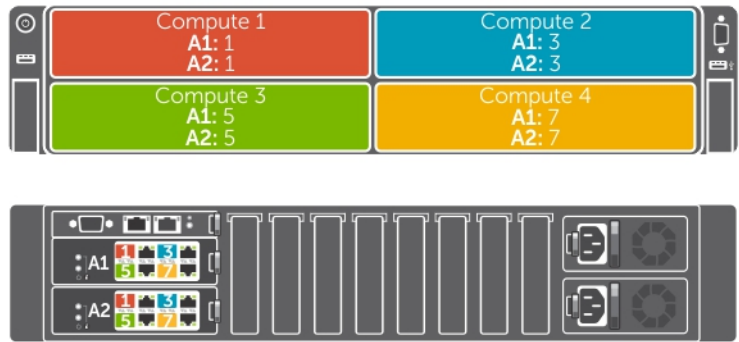

Figure 16. I/O module port mapping—half-width compute sleds with dual port NDC

A half-width compute sled that is configured with dual port Network Daughter Card (NDC) is mapped to a single port on each I/O module. The following table lists the compute sleds and the ports to which they are mapped.

Table 7. I/O module port mapping—half-width compute sleds (dual port NDC)

Compute sled	IO Module A1 (Top)	IO Module A2 (Bottom)
1	1	1
2	3	3
3	5	5
4	7	7

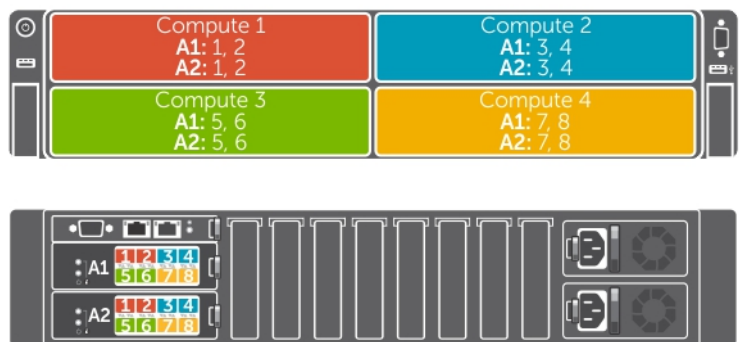

Figure 17. I/O module port mapping—half-width compute sleds with quad port NDC/network output

A half-width compute sled configured with quad-port NDC is mapped to two ports on each I/O module.

A half-width compute sled with four compute nodes is configured with a quad-port network output, which is mapped to two ports on each I/O module. The network traffic from the nodes in the compute sled to the I/O modules in the enclosure is routed through a network switch that is embedded on the compute sled system board. For more information, see the *Dell PowerEdge FM120x4 Owner's Manual* at Dell.com/poweredgemanuals.

The following table lists the compute sleds and the ports to which they are mapped.

Table 8. I/O module port mapping—half-width compute sleds (quad port NDC/network output)

Compute sled	IO Module A1 (Top)	IO Module A2 (Bottom)
1	1, 2	1, 2
2	3, 4	3, 4
3	5, 6	5, 6
4	7, 8	7, 8

I/O module port mapping—eight-bay chassis

In the eight-bay chassis that supports up to eight quarter-width compute sleds, a compute sled is mapped to a single port on each I/O module.

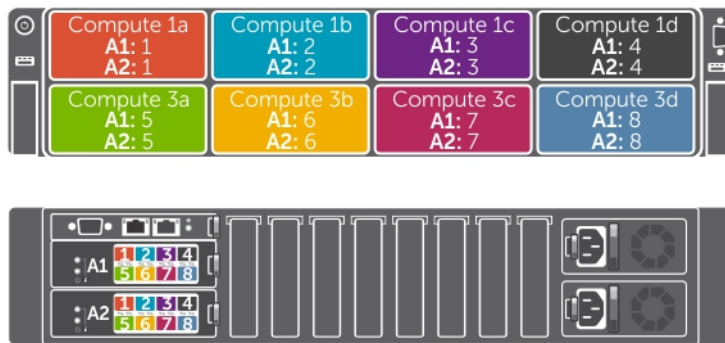

Figure 18. I/O module port mapping—eight-bay chassis

The following table lists the compute sleds and the ports to which they are mapped.

Table 9. I/O module port mapping in eight-bay chassis

Compute sled	IO Module A1 (Top)	IO Module A2 (Bottom)
1a	1	1
1b	2	2
1c	3	3
1d	4	4
3a	5	5
3b	6	6
3c	7	7
3d	8	8

I/O module port mapping—six-bay chassis

The six-bay chassis supports a combination of up to four quarter-width compute sleds and up to two half-width compute sleds.

In the six-bay chassis, a quarter-width compute sled is mapped to one port on each I/O module. A half-width compute sled with quad-port NDC is mapped to two ports on each I/O module.

NOTE: A half-width compute sled with dual-port NDC is mapped to a single port on each I/O module.

NOTE: In the six-bay PowerEdge FX2s configuration that supports storage sleds mapped to quarter-width compute sleds, the I/O module ports are mapped only to the compute sleds. If storage sleds are installed, the corresponding ports on the I/O modules mapped to these slots are not active.

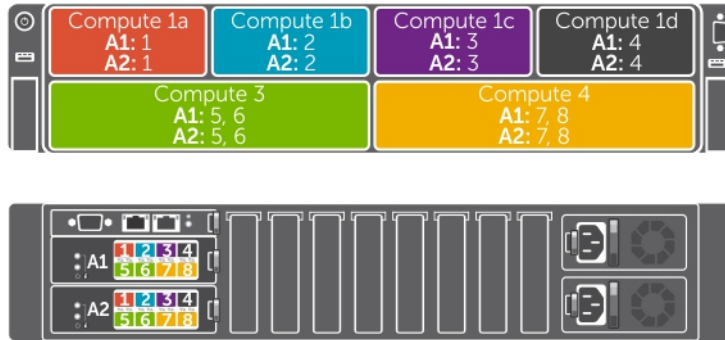

Figure 19. I/O module port mapping—six-bay chassis

The following table lists the compute sleds and the ports to which they are mapped.

Table 10. I/O module port mapping in a six-bay chassis

Compute sled	IO Module A1 (Top)	IO Module A2 (Bottom)
1a	1	1
1b	2	2
1c	3	3
1d	4	4
3	5, 6 (for half-width compute sled with quad-port NDC)	5, 6 (for half-width compute sled with quad-port NDC)
	5 (for half-width compute sled with dual-port NDC)	5 (for half-width compute sled with dual-port NDC)
4	7, 8 (for half-width compute sled with quad-port NDC)	7, 8 (for half-width compute sled with quad-port NDC)
	7 (for half-width compute sled with dual-port NDC)	7 (for half-width compute sled with dual-port NDC)

I/O module port mapping—two-bay chassis

In the two-bay chassis configuration that supports up to two full-width compute sleds, a compute sled is mapped to four ports on each I/O module.

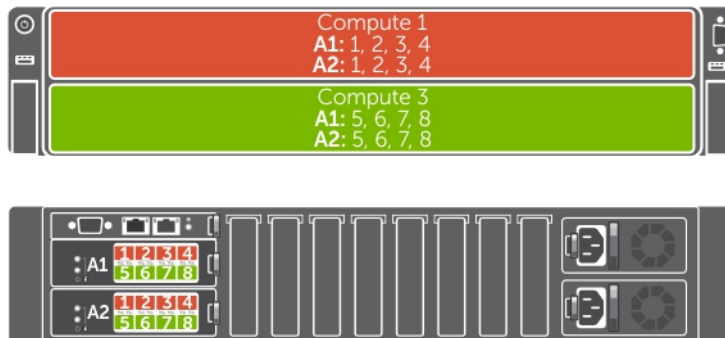

Figure 20. I/O module port mapping—full-width compute sleds

The following table lists the compute sleds and the ports to which they are mapped.

Table 11. I/O module port mapping—full-width compute sleds

Compute sled	I/O Module A1 (Top)	I/O Module A2 (Bottom)
1	1, 2, 3, 4	1, 2, 3, 4
3	5, 6, 7, 8	5, 6, 7, 8

I/O module port mapping—three-bay chassis

The three-bay chassis supports a combination of one full-width compute sled and up to two half-width compute sleds.

In the three-bay chassis, a full-width compute sled is mapped to four ports on each I/O module. A half-width compute sled with quad port NDC is mapped to two ports on each I/O module.

NOTE: A half-width compute sled with dual-port NDC is mapped to a single port on each I/O module.

NOTE: In the three-bay PowerEdge FX2s configuration that supports storage sled(s) mapped to a full-width compute sled, only the compute sled is mapped to the I/O module ports. If storage sleds are installed, the corresponding ports on the I/O modules mapped to these slots are not active.

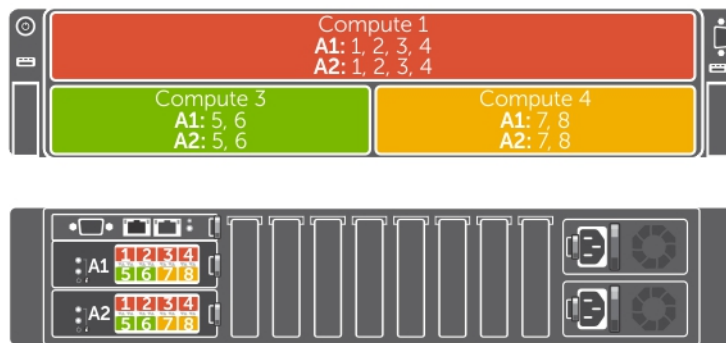

Figure 21. I/O module port mapping—three-bay chassis

The following table lists the compute sleds and the ports to which they are mapped.

Table 12. I/O module port mapping in three-bay chassis

Compute sled	IO Module A1 (Top)	IO Module A2 (Bottom)
1	1, 2, 3, 4	1, 2, 3, 4
3	5, 6 (for half-width compute sled with quad-port NDC) 5 (for half-width compute sled with dual-port NDC)	5, 6 (for half-width compute sled with quad-port NDC) 5 (for half-width compute sled with dual-port NDC)
4	7, 8 (for half-width compute sled with quad-port NDC) 7 (for half-width compute sled with dual-port NDC)	7, 8 (for half-width compute sled with quad-port NDC) 7 (for half-width compute sled with dual-port NDC)

I/O module and PCIe mezzanine card configuration guidelines

- LOM network supports two Ethernet pass-through or switch modules.
- To enable switch configuration before imaging the compute sleds, you must allow the I/O module(s) to power up before turning on the compute sleds.
- Each half-width and quarter-width compute sled installed in the PowerEdge FX2s enclosure supports one PCIe mezzanine card. Each full-width compute sled supports two PCIe mezzanine cards. To locate the PCIe expansion bus slots in the compute sleds, see the

relevant compute sled Owner's Manual at [Dell.com/poweredgemanuals](https://www.dell.com/poweredge/manuals). The PCIe mezzanine cards are mapped to the PCIe expansion slots on the enclosure. For more information, see [PCIe expansion slot mapping](#) on page 27.

NOTE: Only PCIe mezzanine cards can be installed in the compute sleds. Non-PCIe mezzanine cards such as Ethernet, Fibre Channel, or InfiniBand mezzanine cards are not supported. If a non-PCIe mezzanine card is installed in the compute sled, the amber light blinks on the compute sled to indicate a mismatch, and the sled does not power on.

Configuring network settings for the I/O module

You can specify the network settings for the interface used to manage the I/O module.

Before configuring the network settings for the I/O module, make sure the I/O module is turned on.

To configure the network setting, you must have administrator privileges for the LOM network to configure the I/O module in Group A.

You can configure the network settings by using the following:

- CMC Web interface
- RACADM

For more information on configuring the network settings, see the Dell PowerEdge FX2/FX2s CMC User's Guide at [Dell.com/esmanuals](https://www.dell.com/esmanuals).

Expansion bus

Expansion bus refers to the PCIe connections between the compute sleds and the PowerEdge FX2s enclosure. The expansion bus supports PCIe mezzanine cards installed in the compute sleds. PowerEdge FX2s has two PCIe switches integrated on the PCIe switch board to connect the compute sleds to the eight low-profile PCIe expansion slots on the enclosure. Each half-width and quarter-width compute sled supports one PCIe mezzanine card. Each full-width compute sled supports two PCIe mezzanine cards.

NOTE: PowerEdge FX2 does not support expansion bus.

PCIe expansion slot mapping

Your system includes two PCIe switches that are integrated on the PCIe switch board. The PCIe mezzanine card(s) in each compute sled is mapped to the PCIe switches, which are further mapped to the PCIe slots on the PCIe switch board.

NOTE: The PCIe expansion slot mapping is pre-configured.

Related References

[Expansion card types and form factor](#) on page 47

[PCIe slot mapping from compute sleds](#) on page 27

[PCIe slot mapping from compute sleds mapped to storage sleds](#) on page 29

PCIe slot mapping from compute sleds

In PowerEdge FX2s enclosure configurations that support only compute sleds, the PCIe slots are mapped to the compute sleds in the following manner:

- Four-bay chassis—Each half-width compute sled is mapped to two PCIe slots.
- Eight-bay chassis—Each quarter-width compute sled is mapped to one PCIe slot.
- Six-bay chassis—Each quarter-width compute sled is mapped to one PCIe slot. Each half-width compute sled is mapped to two PCIe slots.
- Two-bay chassis—Each full-width compute sled is mapped to four PCIe slots.
- Three-bay chassis—The full-width compute sled is mapped to four PCIe slots. Each half-width compute sled is mapped to two PCIe slots.

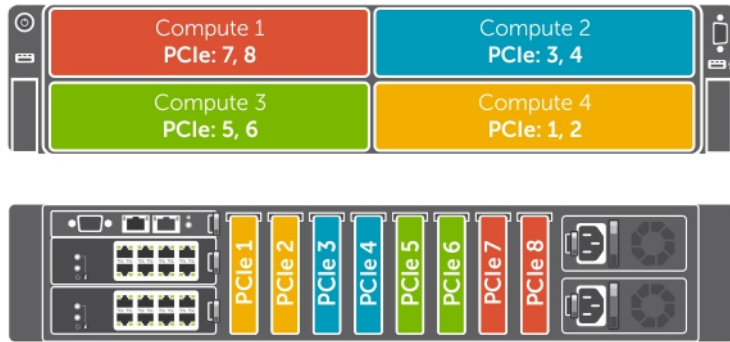

Figure 22. Compute sled to PCIe slot mapping—four-bay chassis

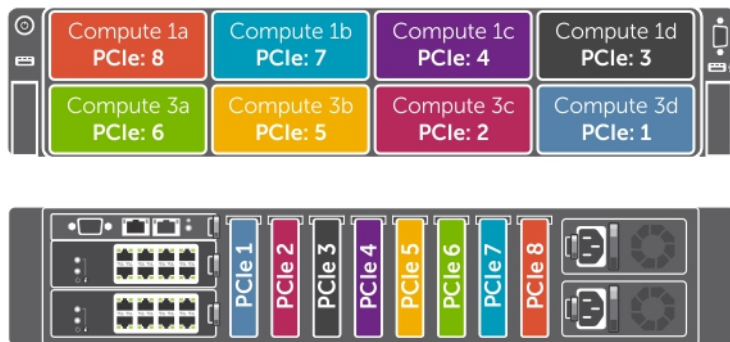

Figure 23. Compute sled to PCIe slot mapping—eight-bay chassis

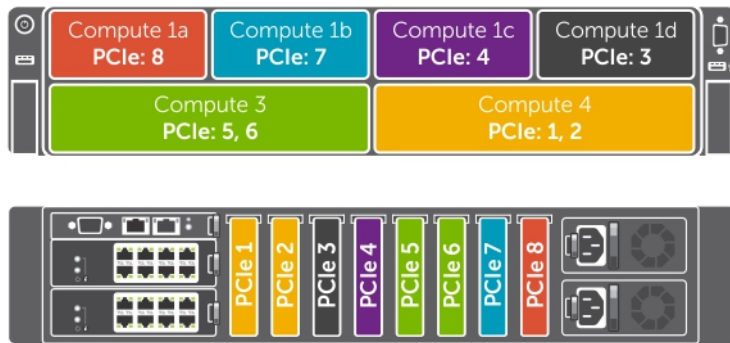

Figure 24. Compute sled to PCIe slot mapping—six-bay chassis

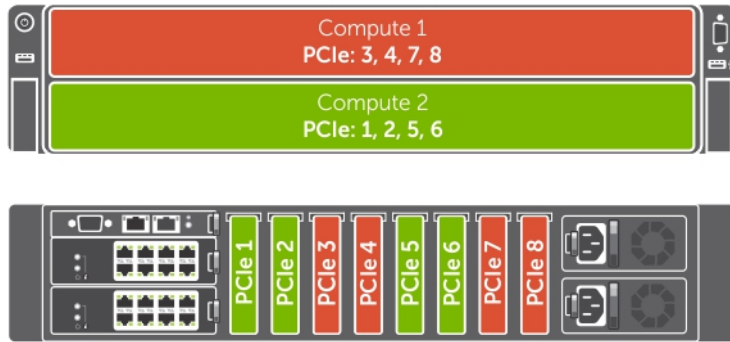

Figure 25. Compute sled to PCIe slot mapping—two-bay chassis

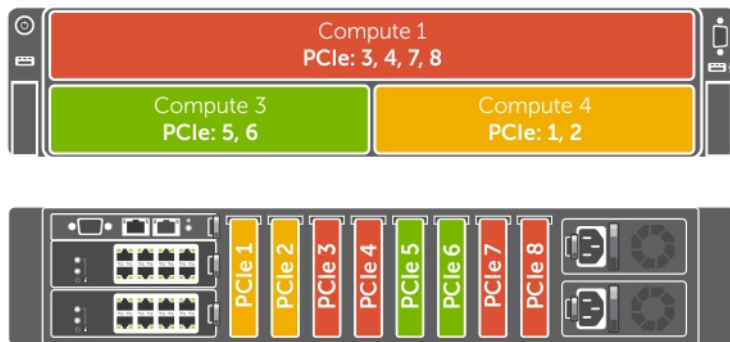

Figure 26. Compute sled to PCIe slot mapping—three-bay chassis

PCIe slot mapping from compute sleds mapped to storage sleds

In PowerEdge FX2s enclosure configurations that support storage sleds mapped to compute sleds, the PCIe slots map only to the compute sleds. When storage sleds are installed in the enclosure, the PCIe slots mapped to these bays are automatically reassigned to the compute sleds installed in the upper bays of the enclosure. The PCIe slot reassignment feature enables you to reassign the PCIe slots from compute sleds in the lower bays to the compute sleds in the upper bays. The PCIe slot reassignment feature applies to enclosure configurations with or without storage sleds. You can enable or disable the PCIe reassignment option by using the CMC web interface, CMC WSMAN, or RACADM. For more information, see the PowerEdge FX2/FX2s CMC User's Guide and the *Dell Chassis Management Controller for PowerEdge FX2/FX2s RACADM Command Line Reference Guide* at [Dell.com/esmmanuals](https://www.dell.com/esmmanuals).

The PCIe slots are mapped to compute sleds in the following manner:

- Four-bay chassis with two half-width compute sleds and two storage sleds—Each half-width compute sled is mapped to four PCIe slots.
- Four-bay chassis with one half-width compute sled and three storage sleds—The half-width compute sled is mapped to eight PCIe slots.
- Three-bay chassis with one full-width compute sled and two storage sleds—The full-width compute sled is mapped to eight PCIe slots.
- Six-bay chassis with four quarter-width compute sleds and two storage sleds—Each quarter-width compute sled is mapped to two PCIe slots.

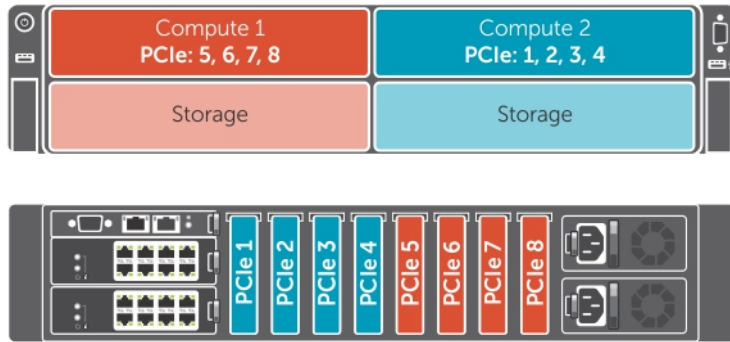

Figure 27. PCIe slot mapping from compute sleds mapped to storage sleds—four-bay chassis

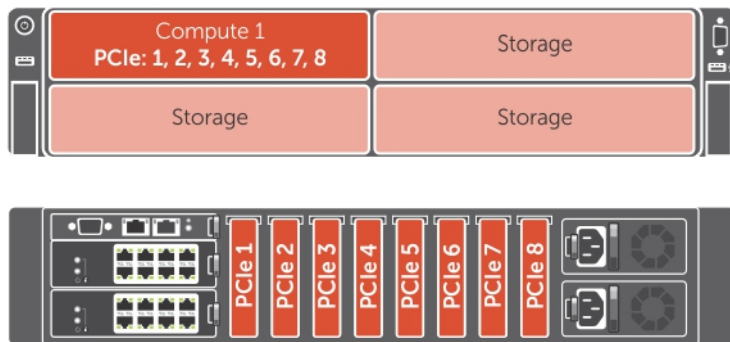

Figure 28. PCIe slot mapping from compute sled mapped to storage sleds—four-bay chassis (with single compute sled)

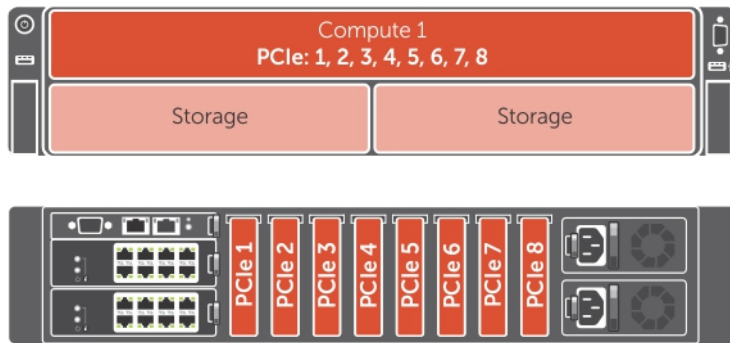

Figure 29. PCIe slot mapping from compute sled mapped to storage sleds—three-bay chassis

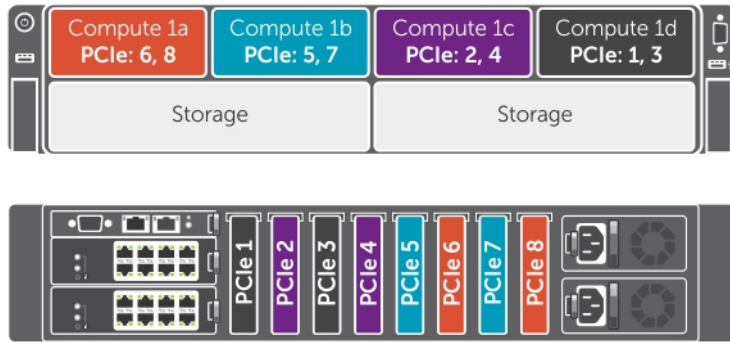

Figure 30. PCIe slot mapping from compute sleds mapped to storage sleds—six-bay chassis

Managing PCIe slots

You can view the status of PCIe slots in the system, both individually as well as all of them at a time. For more information on managing the PCIe slots by using the CMC web interface, see the Dell PowerEdge FX2/FX2s CMC User's Guide at Dell.com/esmanuals.

Internal management network

The internal management network connectivity provides Ethernet management connections between iDRAC on the compute sled and the CMC.

Installing and removing PowerEdge FX2/FX2s enclosure components

This section provides information on installing and removing the enclosure components. For information on removing and installing the sled components, see the relevant sled Owner's Manual at [Dell.com/poweredgemanuals](https://www.dell.com/poweredgemanuals).

Topics:

- [Customer and field replaceable units—PowerEdge FX2/FX2s](#)
- [Safety instructions](#)
- [Before working inside your system](#)
- [After working inside your system](#)
- [Recommended tools](#)
- [System cover](#)
- [Sleds](#)
- [Inside the system](#)
- [CMC module](#)
- [I/O module](#)
- [PCIe module](#)
- [Expansion cards](#)
- [Power supply units](#)
- [Cooling fans](#)
- [Cooling-fan cage](#)
- [PCIe switch board](#)
- [Fan interface board](#)
- [Interposer module](#)
- [Midplane assembly](#)
- [Control panel](#)
- [KVM panel](#)

Customer and field replaceable units—PowerEdge FX2/FX2s

The following components are customer replaceable units (CRUs):









- Sleds
- CMC module
- I/O module(s)
- PCIe modules
- Expansion cards
- Power supply units
- Cooling fans

The following components are field replaceable units (FRUs). Removal and installation procedures should be performed only by Dell certified service technicians.

- Cooling-fan cage
- PCIe switch board (PowerEdge FX2s)
- Fan interface board (PowerEdge FX2)
- Interposer module(s)
- Midplane assembly
- Control panel

- KVM panel

Safety instructions

-  **NOTE:** Whenever you need to lift the system, get others to assist you. To avoid injury, do not attempt to lift the system by yourself.
-  **NOTE:** Opening or removing the system cover when the system is on may expose you to a risk of electric shock.
-  **NOTE:** Exercise care when removing or installing components when the system is on, to avoid the risk of electric shock.
-  **CAUTION:** Do not operate the system without the cover for a duration exceeding three minutes.
-  **CAUTION:** Many repairs may only be done by a certified service technician. You should only perform troubleshooting and simple repairs as authorized in your product documentation, or as directed by the online or telephone service and support team. Damage due to servicing that is not authorized by Dell is not covered by your warranty. Read and follow the safety instructions that are shipped with your product.
-  **NOTE:** It is recommended that you always use a static mat and static strap while working on components inside the system.
-  **NOTE:** To ensure proper operation and cooling, all bays in the system must be populated at all times with either a sled or with a blank.
-  **NOTE:** Dell recommends that you remove the sleds and power supplies from the chassis to reduce weight, before installing the enclosure in the rack.

Before working inside your system

Steps

1. Turn off the compute sleds by using either the CMC, iDRAC, or the compute sled power button. A storage sled turns off when the compute sled(s) to which it is mapped is turned off.
2. Turn off the enclosure and attached peripherals, and disconnect the enclosure from the electrical outlet.

After working inside your system

Steps

1. Reconnect the enclosure to its electrical outlet and turn the enclosure on, including any attached peripherals.
2. Turn on the compute sleds. A storage sled turns on when the compute sled(s) to which it is mapped is turned on.

Recommended tools

You need the following items to perform the procedures in this section:

- #1 and #2 Phillips screwdrivers
- T6, T8, T10, T15, and T20 Torx screwdrivers
- Wrist grounding strap
- Hex screw driver

System cover

Removing the system cover

Prerequisites

CAUTION: Many repairs may only be done by a certified service technician. You should only perform troubleshooting and simple repairs as authorized in your product documentation, or as directed by the online or telephone service and support team. Damage due to servicing that is not authorized by Dell is not covered by your warranty. Read and follow the safety instructions that are shipped with your product.

NOTE: To ensure proper operation and cooling, replace the system cover within three minutes of removal.

1. Ensure that you read the [Safety instructions](#) on page 33.
2. Follow the procedure listed in [Before working inside your system](#) on page 33.

Steps

1. Rotate the cover lock counterclockwise to the unlock position.
2. Press the release latches on both sides of the system toward the cover lock.
3. Slide the cover toward the front of the system and lift the cover away from the system.

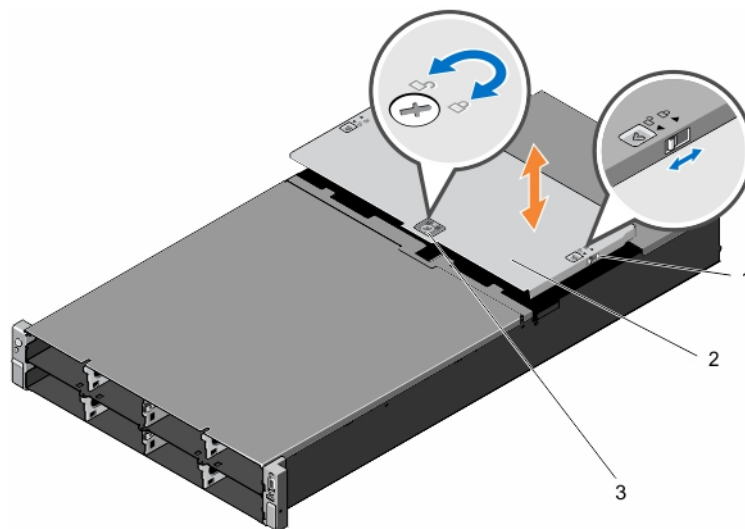

Figure 31. Removing and installing the system cover

- a. release latch (2)
- b. system cover
- c. cover lock

Next steps

Install the system cover.

Related tasks

[Installing the system cover](#) on page 35

Installing the system cover

Prerequisites

CAUTION: Many repairs may only be done by a certified service technician. You should only perform troubleshooting and simple repairs as authorized in your product documentation, or as directed by the online or telephone service and support team. Damage due to servicing that is not authorized by Dell is not covered by your warranty. Read and follow the safety instructions that are shipped with your product.

1. Ensure that you read the [Safety instructions](#) on page 33.
2. Follow the procedure listed in [Before working inside your system](#) on page 33.
3. Remove the system cover.

NOTE: You must remove the system cover to service components inside the system.

Steps

1. Place the bottom edge of the cover, opposite the cover lock, into the slots on the system.
2. Lower the cover onto the system.
3. Slide the system cover toward the back of the system until the system cover is flush with the system surface.
4. Turn the cover lock clockwise to the lock position.

Next steps

Follow the procedure listed in [After working inside your system](#) on page 33.

Related information

[Removing the system cover](#) on page 34

Sleds

CAUTION: To ensure proper operation and cooling, all bays in the system must be replaced with either a sled or a blank within two minutes of removing the sled or blank.

NOTE: Ensure that you have downloaded the latest BIOS on the sled(s) from Dell.com/support.

Removing a compute sled

Prerequisites

CAUTION: Many repairs may only be done by a certified service technician. You should only perform troubleshooting and simple repairs as authorized in your product documentation, or as directed by the online or telephone service and support team. Damage due to servicing that is not authorized by Dell is not covered by your warranty. Read and follow the safety instructions that are shipped with your product.

1. Ensure that you read the [Safety instructions](#) on page 33.
2. Turn off the compute sled by using either the CMC, iDRAC, or the sled power button.

Ensure that the front-panel indicator on the sled is off.

Steps

1. Press the release button on the sled handle to the unlock position.
2. Rotate the sled handle away from the sled to disengage the sled from the midplane connectors.
3. Slide the compute sled out of the enclosure.

CAUTION: To protect the I/O connector pins, install the I/O connector cover every time a sled is removed from the enclosure.

4. Install the I/O connector cover over the I/O connector.

CAUTION: If you are permanently removing the sled, install a sled blank. Operating the system for extended periods of time without a sled blank installed can cause the enclosure to overheat.

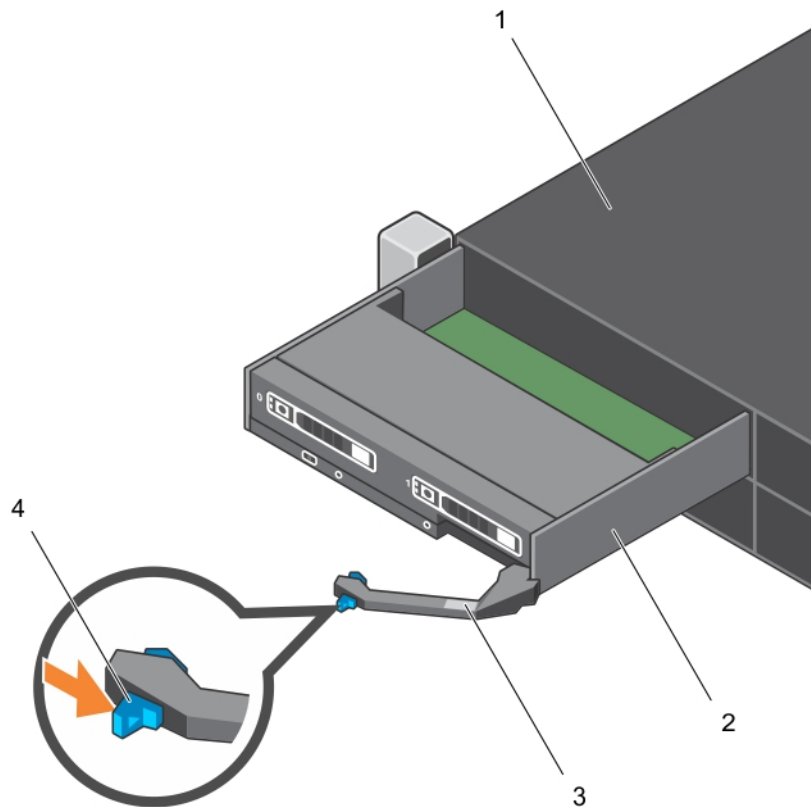

Figure 32. Removing and installing a compute sled

- | | |
|------------------------|----------------------------------|
| 1. enclosure | 2. compute sled |
| 3. compute sled handle | 4. release button on sled handle |

Next steps

Install the compute sled or sled blank.

Related tasks

[Installing a compute sled](#) on page 36

Installing a compute sled

Prerequisites

CAUTION: Many repairs may only be done by a certified service technician. You should only perform troubleshooting and simple repairs as authorized in your product documentation, or as directed by the online or telephone service and support team. Damage due to servicing that is not authorized by Dell is not covered by your warranty. Read and follow the safety instructions that are shipped with your product.

Ensure that you read the [Safety instructions](#) on page 33.

Steps

1. If you are installing a new compute sled, remove the plastic cover from the I/O connector(s) and save for future use.
2. Press the release button on the sled handle to the open position.

3. Align the compute sled with the bay in the enclosure.
4. Slide the sled into the enclosure until the sled connectors are firmly engaged with the midplane connectors. The sled handle rotates toward the enclosure as the sled slides into the enclosure.
5. Press the sled handle to closed position until the release button clicks into place.

Next steps

Turn on the compute sled.

Related information

[Removing a compute sled](#) on page 35

Removing a storage sled

Prerequisites

CAUTION: Many repairs may only be done by a certified service technician. You should only perform troubleshooting and simple repairs as authorized in your product documentation, or as directed by the online or telephone service and support team. Damage due to servicing that is not authorized by Dell is not covered by your warranty. Read and follow the safety instructions that came with the product.

CAUTION: Removing the storage sled from the enclosure when the storage sled is powered on results in loss of data.

CAUTION: To prevent damage to the storage sled locks, use a #2 Phillips screwdriver to turn the sled locks to lock or unlock positions.

1. Ensure that you read the [Safety instructions](#) on page 33.
2. Turn off the compute sled(s) to which the storage sled is mapped, by using the CMC, iDRAC, or the sled power button.
3. Keep the Phillips #2 screwdriver ready.

Steps

1. Using a Phillips #2 screwdriver, turn the storage sled locks on the sled front panel to unlock position.

CAUTION: If you are permanently removing the sled, install a sled blank. Operating the enclosure for extended periods of time without a sled blank installed can cause the enclosure to overheat.

2. Lift the sled release latches upward by 90 degrees, and holding it by the latches, pull the sled out of the enclosure.

CAUTION: To protect the I/O connector pins, install the I/O connector cover every time a sled is removed from the enclosure.

3. Install the I/O connector cover over the I/O connectors.

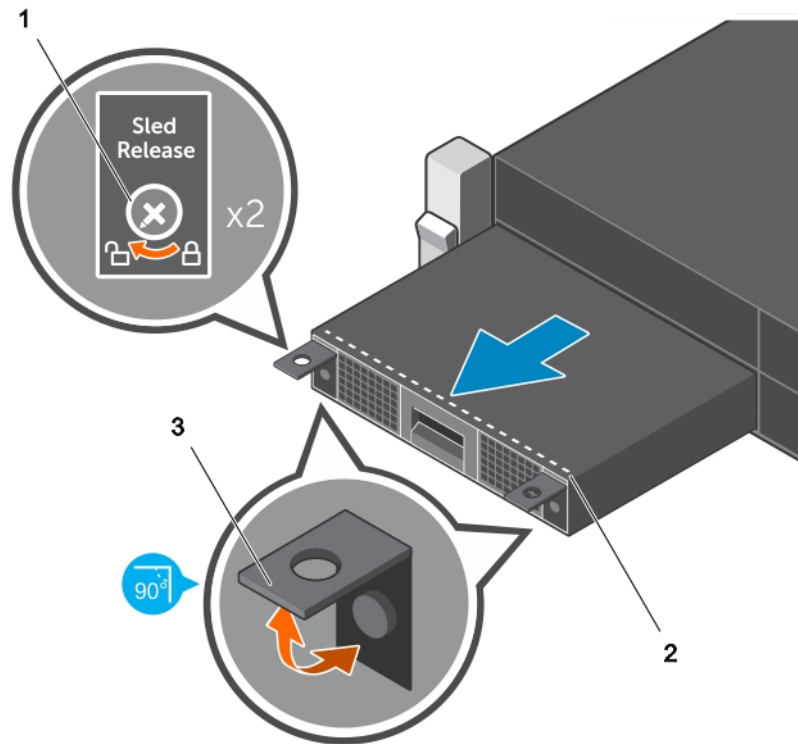

Figure 33. Removing a storage sled

- a. sled lock (2)
- b. dotted line on storage sled
- c. sled release latch (2)

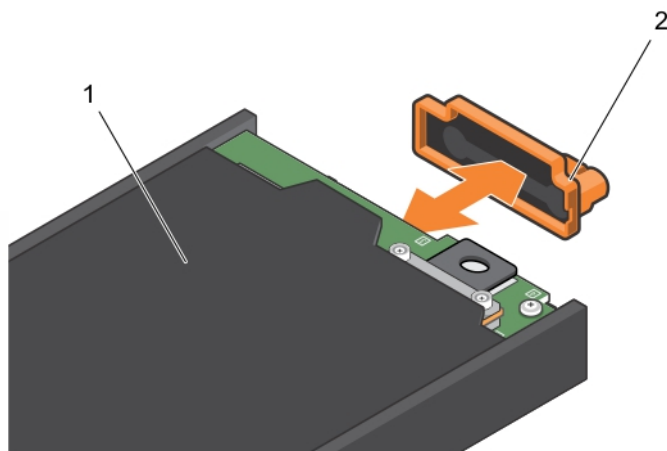

Figure 34. Removing and installing the I/O connector cover

- a. storage sled
- b. I/O connector cover

Next steps

Install the storage sled or sled blank.

Related References







[Safety instructions](#) on page 33

Related tasks



Installing a storage sled on page 39

Installing a storage sled

Prerequisites

-  **CAUTION:** Many repairs may only be done by a certified service technician. You should only perform troubleshooting and simple repairs as authorized in your product documentation, or as directed by the online or telephone service and support team. Damage due to servicing that is not authorized by Dell is not covered by your warranty. Read and follow the safety instructions that came with the product.
 -  **CAUTION:** To prevent damage to the I/O connectors, do not touch the connectors or the connector pins.
 -  **CAUTION:** To prevent damage to the sled locks, use a #2 Phillips screwdriver to turn the sled locks to lock or unlock positions.
 -  **NOTE:** Install the storage sleds in the bottom slots of the PowerEdge FX2s enclosure, beginning from the left (slot 3). In the four-bay chassis, you can also install a storage sled in the top right slot (slot 2) of the enclosure. For more information on sled slot numbering, see the *Dell PowerEdge FX2 and FX2s Enclosure Owner's Manual* at Dell.com/poweredgemanuals.
 -  **NOTE:** If your storage sled has shipped pre-installed in the enclosure, it is recommended that you remove the sled before installing the enclosure in the rack, to reduce chassis weight.
 -  **NOTE:** If you are installing the storage sled in an enclosure that is already powered on, you need not turn off the enclosure to install the storage sled. Only the compute sled(s) to which the storage sled is mapped must be turned off.
1. Ensure that you read the Safety instructions.
 2. Turn off the compute sled to which the storage sled is mapped, by using the CMC, iDRAC, or the power button on the compute sled.
 3. Keep the #2 Phillips screwdriver ready.

Steps

1. If you are installing a new storage sled, remove the I/O connector cover and save for future use.
2. Align the storage sled with the bay in the enclosure.
 -  **CAUTION:** To ensure that a storage sled is properly installed, slide the sled into the enclosure bay until the dotted line on top of the storage sled is not visible from the top edge of the bay in which the storage sled is being installed.
 -  **CAUTION:** If a compute sled is already installed in an enclosure bay above the bay in which you are installing a storage sled, the compute sled may obscure the dotted line on the storage sled. Do not use the compute sled installed in the top enclosure bay as a point of reference for visibility of the dotted line on top of the storage sled. For the storage sled to be properly installed, ensure that the dotted line on the storage sled is not visible from the top edge of the bay in which the storage sled is installed.
3. Slide the storage sled into the enclosure until the dotted line on top of the sled is not visible from the top edge of the bay, and the sled clicks into place.
4. Turn the storage sled locks to the lock position, to secure the sled in the enclosure.
 -  **CAUTION:** Ensure that the sled locks are in locked position before opening the storage sled drive drawer, as the storage sled must be locked in the enclosure before you open the drive drawer.

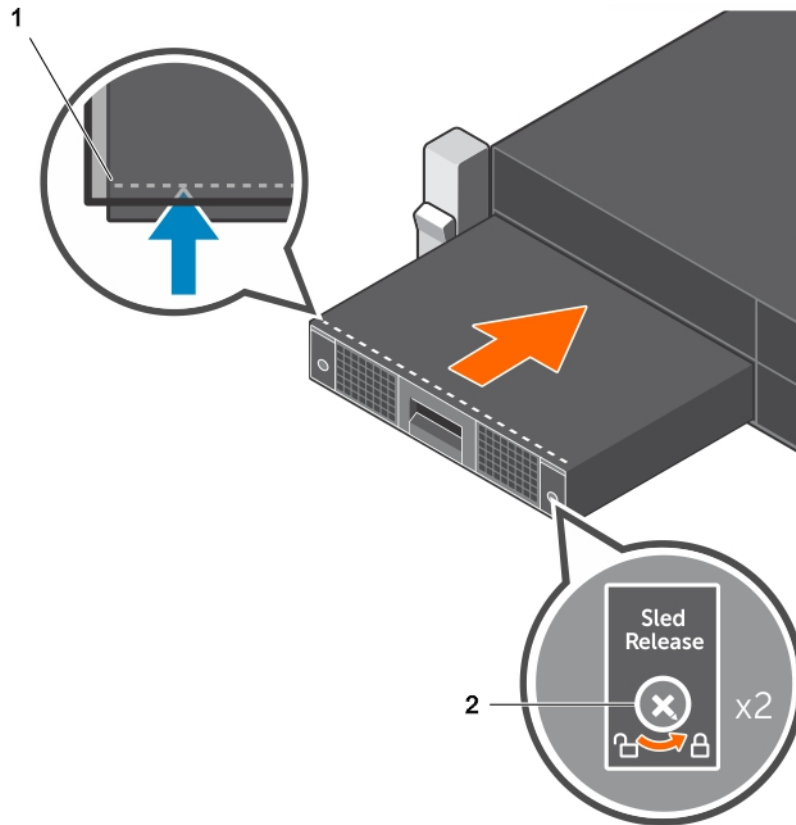

Figure 35. Installing a storage sled

- a. dotted line on storage sled
- b. sled lock (2)

Next steps

Turn on the compute sled(s) to which the storage sled is mapped. The storage sled turns on.

Related References

[Safety instructions](#) on page 33

Related information

[Removing a storage sled](#) on page 37

Inside the system

CAUTION: Many repairs may only be done by a certified service technician. You should only perform troubleshooting and simple repairs as authorized in your product documentation, or as directed by the online or telephone service and support team. Damage due to servicing that is not authorized by Dell is not covered by your warranty. Read and follow the safety instructions that are shipped with your product.

NOTE: Components that are hot-swappable are marked orange, and touch points on the components are marked blue.

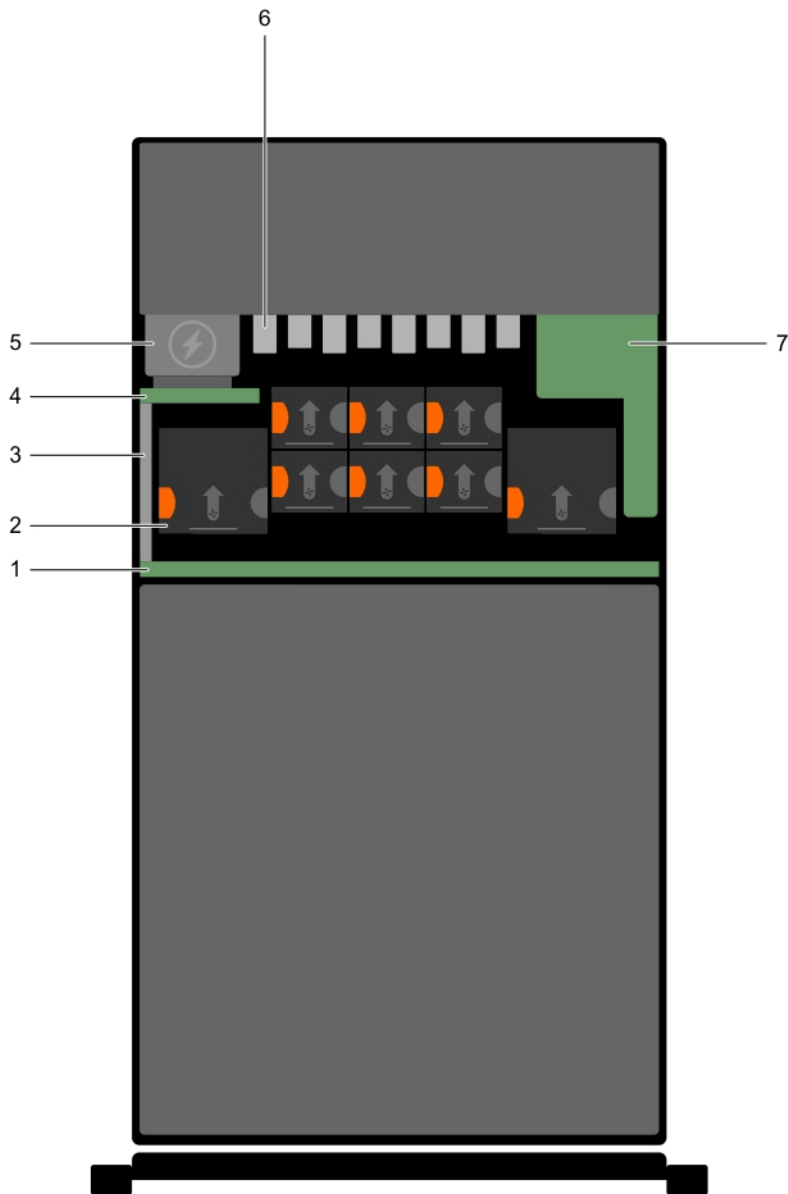

Figure 36. Inside the system—PowerEdge FX2s

- | | |
|--------------------------|---------------------------|
| 1. midplane | 2. fan (8) |
| 3. power bus bar | 4. power interposer board |
| 5. Power Supply Unit (2) | 6. PCIe module (8) |
| 7. CMC module | |

NOTE: PowerEdge FX2 does not support PCIe modules.

CMC module

Your system supports a hot-swappable CMC module that provides multiple systems management functions.

Removing the CMC module

Prerequisites

CAUTION: Many repairs may only be done by a certified service technician. You should only perform troubleshooting and simple repairs as authorized in your product documentation, or as directed by the online or telephone service and support team. Damage due to servicing that is not authorized by Dell is not covered by your warranty. Read and follow the safety instructions that are shipped with your product.

NOTE: You must remove the CMC module to replace a faulty module or service other components inside the system.

NOTE: The CMC module is hot-swappable.

Ensure that you read the [Safety instructions](#) on page 33.

Steps

1. Disconnect the cables attached to the CMC module.
2. Press the release latch and slide the CMC module out of the enclosure.

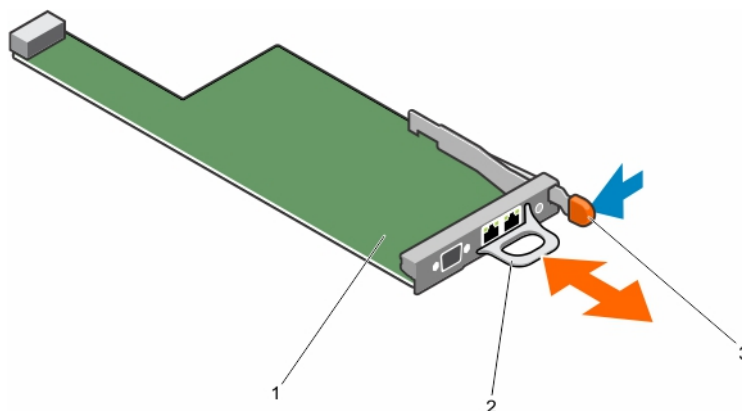

Figure 37. Removing and installing the CMC module

- a. CMC module
- b. CMC module handle
- c. release latch

Next steps

Install the CMC module.

Related tasks

[Installing the CMC module](#) on page 42

Installing the CMC module

Prerequisites

CAUTION: Many repairs may only be done by a certified service technician. You should only perform troubleshooting and simple repairs as authorized in your product documentation, or as directed by the online or telephone service and support team. Damage due to servicing that is not authorized by Dell is not covered by your warranty. Read and follow the safety instructions that are shipped with your product.

1. Ensure that you read the [Safety instructions](#) on page 33.
2. Remove the CMC module.

NOTE: You must remove the CMC module to replace a faulty module or service other components inside the system.

Steps

1. Unpack the CMC module and prepare it for installation.
2. Slide the CMC module into the enclosure until the CMC module connector engages with the pins on the midplane.
3. Connect the cables to the CMC module.

Related information

[Removing the CMC module](#) on page 42

CMC module SD card

The SD card slot on the CMC module supports an optional WWN/MAC feature that allows slot-based WWN/MACs for the sleds, simplifying sled installation and replacement.

Prerequisites

CAUTION: Many repairs may only be done by a certified service technician. You should only perform troubleshooting and simple repairs as authorized in your product documentation, or as directed by the online or telephone service and support team. Damage due to servicing that is not authorized by Dell is not covered by your warranty. Read and follow the safety instructions that are shipped with your product.

1. Ensure that you read the [Safety instructions](#) on page 33.
2. Remove the CMC module.

NOTE: Verify that the write protection latch is in the unlock position.

Steps

Locate the SD card slot on the bottom of the CMC module and insert the contact-pin end of the card into the slot with the label on the card facing upwards.

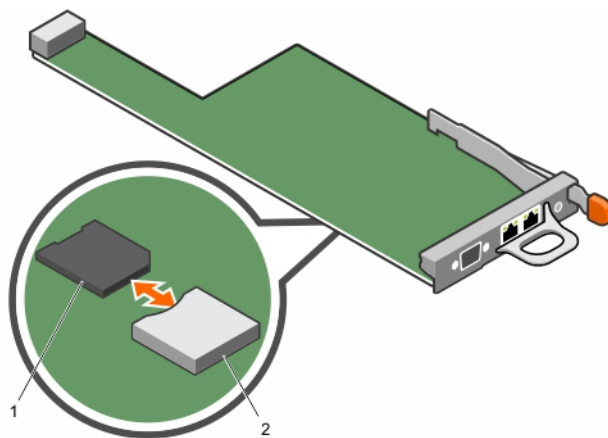

Figure 38. Removing and installing a CMC module SD card

- a. SD card
- b. SD card connector

Next steps

Install the CMC module and reattach any cables that were disconnected.

The SD card is activated automatically.

Related tasks

[Removing the CMC module](#) on page 42

[Installing the CMC module](#) on page 42

I/O module

Your system supports up to two hot-swappable I/O modules that provide external network connectivity.

Removing an I/O module

Prerequisites

CAUTION: Many repairs may only be done by a certified service technician. You should only perform troubleshooting and simple repairs as authorized in your product documentation, or as directed by the online or telephone service and support team. Damage due to servicing that is not authorized by Dell is not covered by your warranty. Read and follow the safety instructions that are shipped with your product.

NOTE: You must remove an I/O module to replace a faulty module or service other components of the system.

NOTE: An I/O module is hot-swappable.

Ensure that you read the [Safety instructions](#) on page 33.

Steps

1. Disconnect the cables attached to the I/O module.
2. Press the release latch and slide the I/O module out of the enclosure.

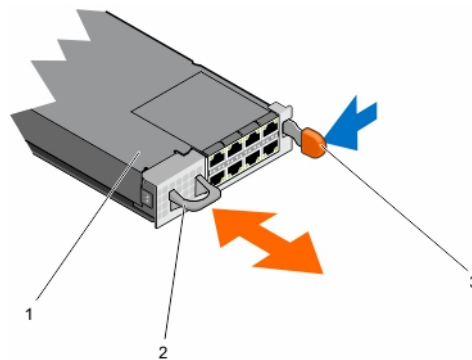

Figure 39. Removing and installing an I/O module

- a. I/O module
- b. I/O module handle
- c. release latch

Next steps

Install the I/O module.

Related tasks

[Installing an I/O module](#) on page 44

Installing an I/O module

Prerequisites

CAUTION: Many repairs may only be done by a certified service technician. You should only perform troubleshooting and simple repairs as authorized in your product documentation, or as directed by the online or telephone service and support team. Damage due to servicing that is not authorized by Dell is not covered by your warranty. Read and follow the safety instructions that are shipped with your product.

1. Ensure that you read the [Safety instructions](#) on page 33.

Steps

1. Unpack the I/O module and prepare it for installation.
For instructions, see the documentation that is shipped with the I/O module.
2. Slide the I/O module into the enclosure until it engages with the connector on the midplane and the release latch snaps into place.
3. Connect all cables that must be attached to the I/O module.
See the I/O module documentation for information about its cable connections.

Related information

[Removing an I/O module](#) on page 44

PCIe module

PowerEdge FX2s supports eight PCIe modules. Each PCIe module has an expansion card slot in which a low profile expansion card can be installed.

 **NOTE:** PowerEdge FX2 does not support PCIe modules.

Removing a PCIe module

Prerequisites

 **CAUTION:** Many repairs may only be done by a certified service technician. You should only perform troubleshooting and simple repairs as authorized in your product documentation, or as directed by the online or telephone service and support team. Damage due to servicing that is not authorized by Dell is not covered by your warranty. Read and follow the safety instructions that came with the product.

 **CAUTION:** The PCIe module is a warm-swappable component. The PCIe slot in a PCIe module is assigned to a compute sled. Removing or adding a PCIe module while the compute sled to which it is assigned is on can result in an error condition.

 **NOTE:** You must remove a PCIe module to replace a faulty module, install or replace an expansion card in the PCIe module, or service other components inside the system.

 **NOTE:** The following procedure is only applicable to the PowerEdge FX2s system.

Ensure that you read the [Safety instructions](#) on page 33.

Steps

1. Turn off the compute sled to which the PCIe slot in the PCIe module is assigned, by using either the CMC, iDRAC, or sled power button.
2. Press the release latch and slide the PCIe module out of the enclosure.

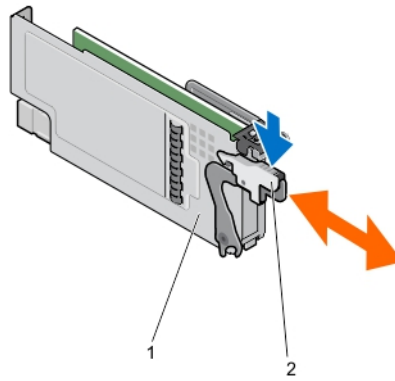

Figure 40. Removing and installing a PCIe module

- a. PCIe module
- b. release latch

Next steps

Install the PCIe module.

Related tasks

[Installing a PCIe module](#) on page 46

Installing a PCIe module

Prerequisites

CAUTION: Many repairs may only be done by a certified service technician. You should only perform troubleshooting and simple repairs as authorized in your product documentation, or as directed by the online or telephone service and support team. Damage due to servicing that is not authorized by Dell is not covered by your warranty. Read and follow the safety instructions that came with the product.

CAUTION: The PCIe module is a warm-swappable component. The PCIe slot in a PCIe module is assigned to a compute sled. Removing or adding a PCIe module while the compute sled to which it is assigned is on can result in an error condition.

1. Ensure that you read the [Safety instructions](#) on page 33.
2. Remove the PCIe module.

NOTE: You must remove a PCIe module to replace a faulty module, install or replace an expansion card in the PCIe module, or service other components inside the system.

Steps

1. Remove the PCIe module connector cover.
2. Install an expansion card or filler bracket.
3. Slide the PCIe module into the enclosure until it engages with the connector on the PCIe switch board and the release latch snaps into place.

Next steps

Turn on the compute sled to which the PCIe slot in the PCIe module is assigned.

Related information

[Removing a PCIe module](#) on page 45

Expansion cards

Expansion card types and form factor

The following table describes the types of expansion cards supported on the PowerEdge FX2s enclosure.

Table 13. Expansion card types and form factor

Card Type	Form Factor
10 Gb NICs	Low profile
1 Gb NICs	Low profile
PERC H830	Low profile
12 Gbps SAS HBA	Low profile
FC8 and FC16 HBA	Low profile

Related information

[PCIe expansion slot mapping](#) on page 27

Expansion card operational power status

The following table provides information on the operational power status of expansion cards when they are installed in a PCIe slot mapped to a compute sled.

Table 14. Expansion card operational power status

Chassis status	Compute sled status	Expansion card status
Off	Off	Off
Standby	Off	Off
On	Off	Off
On	On	On

The following table provides information on the operational power status of an expansion card when it is replaced in the PCIe slot.

Table 15. Expansion card operational power status

Chassis status	Compute sled status	Expansion card status
On	Off	Off
On	On	Off

 **NOTE:** To verify if a PCIe slot is powered on, see [PCIe module indicators](#) on page 47.

PCIe module indicators

The PCIe expansion card slots are warm-swappable. An expansion card is powered down when the compute sled associated to it is turned off.

The PCIe module indicators provide the following information about the PCIe slots inside the modules:

Power indicator pattern	Description
Steady Blue	The slot is receiving power.
Blinking Blue	The ID button on the front panel is pressed. The selected compute sled and its associated components including LEDs on the slot blink.
Off	Power supply to the slot is off, and the expansion card can be removed.

Attention indicator pattern	Description
Steady Amber	The slot is in fault condition.
Off	The slot is operating normally.

Removing an expansion card

Prerequisites

CAUTION: Many repairs may only be done by a certified service technician. You should only perform troubleshooting and simple repairs as authorized in your product documentation, or as directed by the online or telephone service and support team. Damage due to servicing that is not authorized by Dell is not covered by your warranty. Read and follow the safety instructions that are shipped with your product.

1. Ensure that you read the [Safety instructions](#) on page 33..
2. Turn off the compute sled to which the expansion card is assigned.
3. Remove the PCIe module.

Steps

1. Open the expansion card release latch.
2. Grasp the expansion card by its edges, and remove it from the expansion card connector on the PCIe module.
3. If you are removing the card permanently, install a metal filler bracket over the empty expansion slot opening and close the release latch.

NOTE: You must install a filler bracket over an empty expansion card slot to maintain Federal Communications Commission (FCC) certification of the system. The brackets also keep dust and dirt out of the system and aid in proper cooling and airflow inside the system. The filler bracket is necessary to maintain proper thermal conditions.

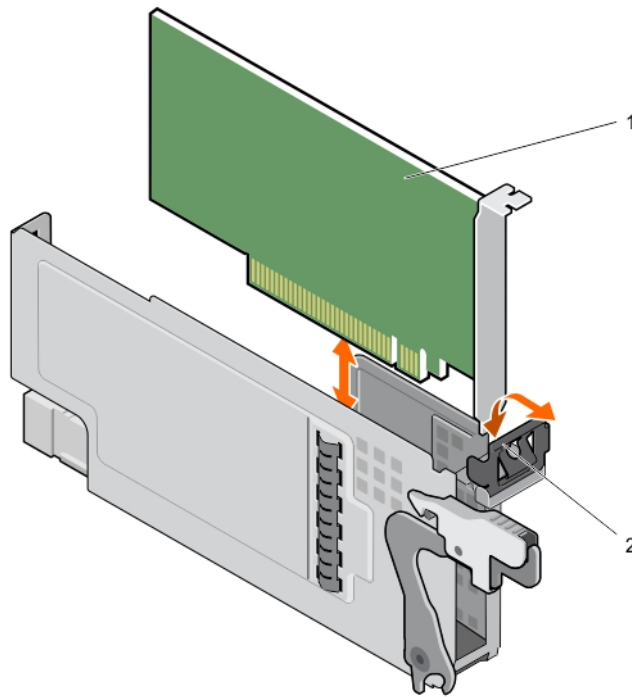

Figure 41. Removing and installing an expansion card

- a. expansion card
- b. release latch

Next steps

1. Install the PCIe module.
2. Turn on the compute sled to which the expansion card is mapped.

Related tasks

- [Removing a PCIe module](#) on page 45
- [Installing a PCIe module](#) on page 46

Installing an expansion card

Prerequisites

CAUTION: Many repairs may only be done by a certified service technician. You should only perform troubleshooting and simple repairs as authorized in your product documentation, or as directed by the online or telephone service and support team. Damage due to servicing that is not authorized by Dell is not covered by your warranty. Read and follow the safety instructions that are shipped with your product.

1. Ensure that you read the [Safety instructions](#) on page 33.
2. Turn off the compute sled to which the expansion card is assigned.
3. Remove the PCIe module.
4. Open the expansion card release latch.
5. Remove the filler bracket.

Steps

1. Unpack the expansion card and prepare it for installation.
For instructions, see the documentation shipped with the card.
2. Holding the card by its edges, position the card so that the card-edge connector aligns with the expansion card connector on the PCIe module.
3. Insert the card-edge connector firmly into the expansion card connector until the card is fully seated.

4. Close the expansion card release latch.

Next steps

1. Install the PCIe module.
2. Turn on the compute sled to which the expansion card is assigned.

Related tasks

[Removing a PCIe module](#) on page 45

[Installing a PCIe module](#) on page 46

Power supply units

Your system supports two hot-swappable power supply units (PSUs) in 1+1 redundant or 2+0 non-redundant configurations.

 **CAUTION:** Unsupported PSU configurations can result in a PSU mismatch condition and failure to power on.

 **NOTE:** Ensure all PSUs are of the same rated output capacity, generation, and input voltage.

 **NOTE:** Unsupported PSU configurations are two or more PSUs that do not share the same supported model, rated output capacity, generation, or input voltage.

 **NOTE:** The PSUs have internal fans that provide thermal cooling to these units. A PSU must be replaced if an internal fan failure occurs.

Removing a power supply unit

Prerequisites

 **CAUTION:** Many repairs may only be done by a certified service technician. You should only perform troubleshooting and simple repairs as authorized in your product documentation, or as directed by the online or telephone service and support team. Damage due to servicing that is not authorized by Dell is not covered by your warranty. Read and follow the safety instructions that are shipped with your product.

 **CAUTION:** Ensure that a power supply unit (PSU) is not operational at the time of its removal. Check the PSU redundancy configuration before removing a PSU.

 **NOTE:** The PSUs are hot-swappable. Remove and replace only one PSU at a time in a system that is turned on.

 **NOTE:** You must remove a PSU to replace a faulty PSU, service other components of the system, or to reduce chassis weight when installing the enclosure in the rack.

 **NOTE:** To switch to a new PSU rated output capacity, generation, or input voltage, you must first power down the chassis before changing the PSU configuration.

Ensure that you read the [Safety instructions](#) on page 33.

Steps

1. Disconnect the power cable from the power source and from the PSU that you intend to remove.
2. Press the release latch and slide the PSU out of the chassis.

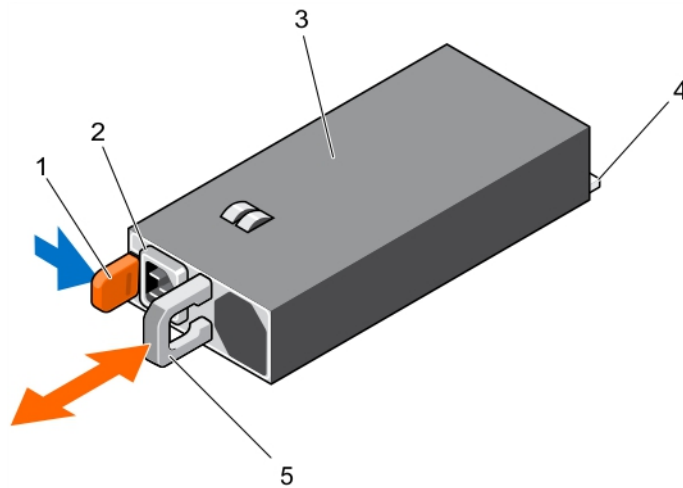

Figure 42. Removing and installing a PSU

- | | |
|------------------|------------------------|
| 1. release latch | 2. PSU cable connector |
| 3. PSU | 4. connector |
| 5. PSU handle | |

Next steps

1. Install the PSU.
2. Connect the power cable to the PSU and plug the cable into a power outlet.

Related tasks

[Installing a power supply unit](#) on page 51

Installing a power supply unit

Prerequisites

CAUTION: Many repairs may only be done by a certified service technician. You should only perform troubleshooting and simple repairs as authorized in your product documentation, or as directed by the online or telephone service and support team. Damage due to servicing that is not authorized by Dell is not covered by your warranty. Read and follow the safety instructions that are shipped with your product.

NOTE: When installing, hot-swapping, or hot-adding a new power supply unit (PSU), allow several seconds for the system to recognize the PSU and determine its status. The PSU status indicator turns green to indicate that the PSU is functioning properly.

1. Ensure that you read the [Safety instructions](#) on page 33.
2. Remove the PSU.

NOTE: You must remove a power supply to replace a faulty power supply, service other components of the system, or to reduce chassis weight when installing the enclosure in the rack.

Steps

1. Slide the PSU into the enclosure until the PSU is fully seated and the release latch snaps into place.

CAUTION: When connecting the power cable, secure the cable with the strap.

2. Connect the power cable to the PSU and plug the cable into a power outlet.

Related information



[Removing a power supply unit](#) on page 50

Cooling fans

Your system supports eight hot-swappable cooling fans that provide cooling to the I/O components in the system.







To provide increased cooling to the PCIe components in the system, you can change the **Fan Offset** options from the CMC web interface.

For more information on the **Fan Offset** properties, see *Advanced Fan Configuration* in the *CMC Online Help*.

-  **NOTE:** If you are removing a fan, replace it immediately with another fan. Operating the system for an extended period of time without a fan installed can cause the enclosure to overheat.
-  **NOTE:** In the event of a problem with a particular fan, the fan number is referenced by the system's management software, allowing you to easily identify and replace the appropriate fan by noting the fan numbers on the cooling-fan bay. If any of the fans fail, the LEDs on the fan light up.
-  **NOTE:** The cooling fans in your system are shipped in two sizes of 80 mm and 60 mm width.

Removing a cooling fan

Prerequisites

-  **NOTE:** Opening or removing the system cover when the system is on may expose you to a risk of electric shock. Exercise utmost care while removing or installing cooling fans.
 -  **NOTE:** The cooling fan can continue to spin for some time after it has been powered down. Allow time for the fan to stop spinning before removing it from the system.
 -  **CAUTION:** Many repairs may only be done by a certified service technician. You should only perform troubleshooting and simple repairs as authorized in your product documentation, or as directed by the online or telephone service and support team. Damage due to servicing that is not authorized by Dell is not covered by your warranty. Read and follow the safety instructions that are shipped with your product.
 -  **CAUTION:** The cooling fans are hot-swappable. To maintain proper cooling while the system is on, replace only one fan at a time.
 -  **CAUTION:** To ensure proper operation and cooling, you must replace a cooling fan within two minutes of removal.
 -  **NOTE:** You must remove a cooling fan to replace a faulty fan or service other components in the system.
 -  **NOTE:** The procedure for removing each fan is identical.
1. Ensure that you read the [Safety instructions](#) on page 33.
 2. Follow the procedure listed in [Before working inside your system](#) on page 33.
 3. Remove the system cover.

Steps

Locate the fan you want to remove, press the fan release tab, and lift the cooling fan out of the cooling-fan cage.

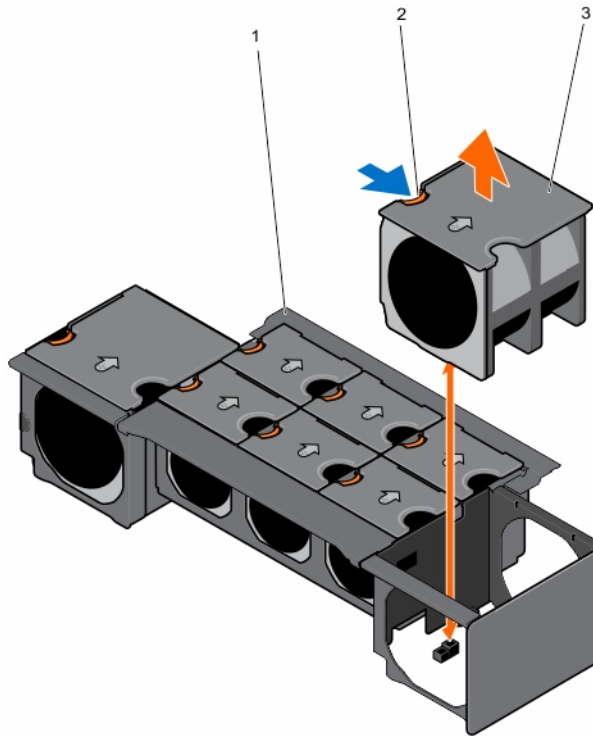

Figure 43. Removing and installing a cooling fan

- a. cooling-fan cage
- b. fan release tab
- c. cooling fan (8)

Next steps

Install the cooling fan.

Related tasks

- [Installing a cooling fan](#) on page 53
- [Removing the system cover](#) on page 34

Installing a cooling fan

Prerequisites

CAUTION: Many repairs may only be done by a certified service technician. You should only perform troubleshooting and simple repairs as authorized in your product documentation, or as directed by the online or telephone service and support team. Damage due to servicing that is not authorized by Dell is not covered by your warranty. Read and follow the safety instructions that are shipped with your product.

1. Ensure that you read the [Safety instructions](#) on page 33.
2. Remove the cooling fan.

NOTE: You must remove a cooling fan to replace a faulty fan or service other components in the system.

Steps

1. Align the plug at the base of the cooling fan with the connector on the PCIe switch board/fan interface board.
2. Slide the cooling fan into the chassis until the plug engages with the connector on the PCIe switch board/fan interface board.

Next steps

1. Install the system cover.

2. Follow the procedure listed in [After working inside your system](#) on page 33.

Related tasks

[Installing the system cover](#) on page 35

Related information

[Removing a cooling fan](#) on page 52

Cooling-fan cage

Removing the cooling-fan cage

Prerequisites

CAUTION: Many repairs may only be done by a certified service technician. You should only perform troubleshooting and simple repairs as authorized in your product documentation, or as directed by the online or telephone service and support team. Damage due to servicing that is not authorized by Dell is not covered by your warranty. Read and follow the safety instructions that are shipped with your product.

NOTE: This is a field replaceable unit (FRU). Removal and installation procedures must be performed only by Dell certified service technicians.

NOTE: You must remove the cooling-fan cage to service other components inside the system.

1. Ensure that you read the [Safety instructions](#) on page 33.
2. Follow the procedure listed in [Before working inside your system](#) on page 33.
3. Remove the system cover.
4. Remove the cooling fans.

Steps

1. Loosen the six screws that secure the cooling-fan cage to the system.
2. Lift the cooling-fan cage out of the system.

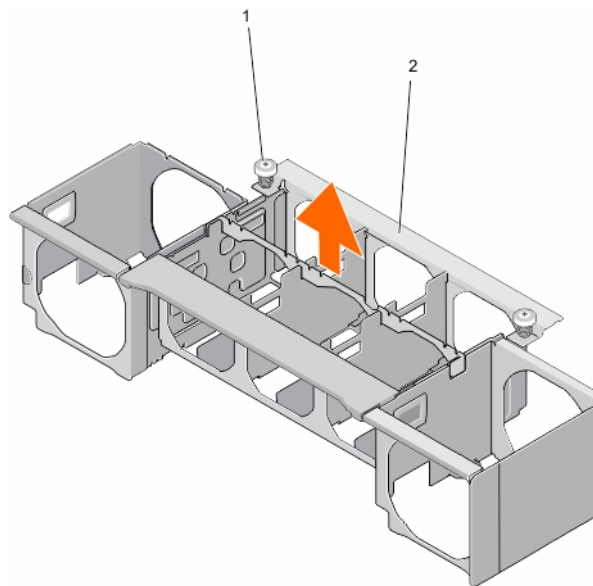

Figure 44. Removing and installing the cooling-fan cage

- a. screw (6)
- b. cooling-fan cage

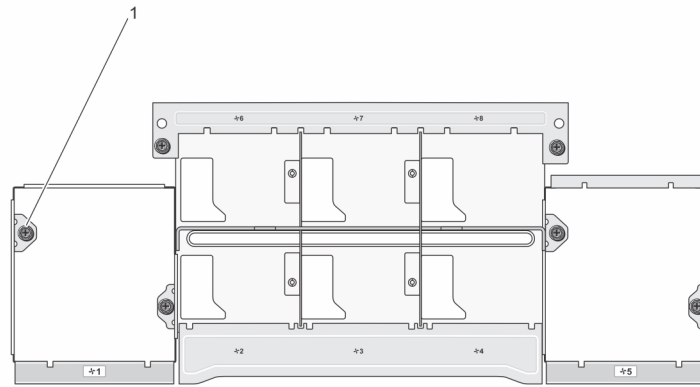

Figure 45. Cooling-fan cage top view

- a. screw location (6)

Next steps

Install the cooling-fan cage.

Related tasks

[Installing the cooling-fan cage](#) on page 55

[Removing the system cover](#) on page 34

[Removing a cooling fan](#) on page 52

Installing the cooling-fan cage

Prerequisites

CAUTION: Many repairs may only be done by a certified service technician. You should only perform troubleshooting and simple repairs as authorized in your product documentation, or as directed by the online or telephone service and support team. Damage due to servicing that is not authorized by Dell is not covered by your warranty. Read and follow the safety instructions that are shipped with your product.

NOTE: This is a field replaceable unit (FRU). Removal and installation procedures must be performed only by Dell certified service technicians.

1. Ensure that you read the [Safety instructions](#) on page 33.
2. Follow the procedure listed in [Before working inside your system](#) on page 33.
3. Remove the cooling-fan cage.

NOTE: You must remove the cooling-fan cage to service other components inside the system.

Steps

1. Lower the cooling-fan cage into the system.

NOTE: Ensure that there are no cables in the way when placing the cooling-fan cage into the system.

2. Tighten the screws until the cooling-fan cage engages with the system.

Next steps

1. Install the cooling fans.
2. Install the system cover.
3. Follow the procedure listed in [After working inside your system](#) on page 33.

Related tasks

[Installing a cooling fan](#) on page 53

[Installing the system cover](#) on page 35

Related information

[Removing the cooling-fan cage](#) on page 54

PCIe switch board

The PCIe switch board is supported on the PowerEdge FX2s enclosure. The following procedure is applicable to the PowerEdge FX2s enclosure.

Removing the PCIe switch board

Prerequisites

CAUTION: Many repairs may only be done by a certified service technician. You should only perform troubleshooting and simple repairs as authorized in your product documentation, or as directed by the online or telephone service and support team. Damage due to servicing that is not authorized by Dell is not covered by your warranty. Read and follow the safety instructions that came with the product.

NOTE: This is a field replaceable unit (FRU). Removal and installation procedures must be performed only by Dell certified service technicians.

NOTE: You must remove the PCIe switch board to replace a faulty switch board or service other components in the system.

1. Ensure that you read the [Safety instructions](#) on page 33.
2. Follow the procedure listed in [Before working inside your system](#) on page 33.
3. Remove the following:
 - system cover
 - cooling fans
 - cooling-fan cage
 - PCIe modules

Steps

1. Loosen the two spring-loaded screws that secure the PCIe switch board to the system.
2. Press down the release latch.
The two levers are released.
3. Holding the two levers, pull the PCIe switch board out of the system.

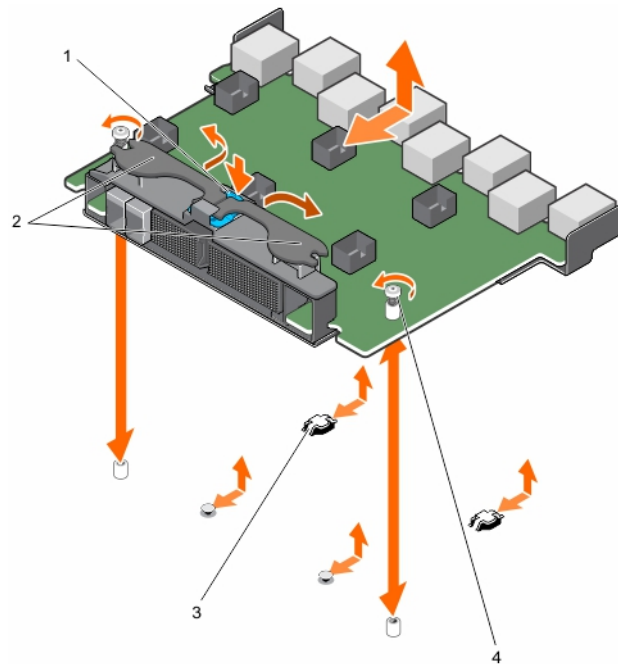

Figure 46. Removing and installing the PCIe switch board

- | | |
|------------------|----------------------------|
| 1. release latch | 2. lever (2) |
| 3. notch (4) | 4. spring-loaded screw (2) |

Next steps

Install the PCIe switch board.

Related tasks

- [Installing the PCIe switch board](#) on page 57
- [Removing the system cover](#) on page 34
- [Removing a cooling fan](#) on page 52
- [Removing the cooling-fan cage](#) on page 54
- [Removing a PCIe module](#) on page 45

Installing the PCIe switch board

Prerequisites

CAUTION: Many repairs may only be done by a certified service technician. You should only perform troubleshooting and simple repairs as authorized in your product documentation, or as directed by the online or telephone service and support team. Damage due to servicing that is not authorized by Dell is not covered by your warranty. Read and follow the safety instructions that came with the product.

NOTE: This is a field replaceable unit (FRU). Removal and installation procedures must be performed only by Dell certified service technicians.

1. Ensure that you read the [Safety instructions](#) on page 33.
2. Follow the procedure listed in [Before working inside your system](#) on page 33.
3. Remove the PCIe switch board.

NOTE: You must remove the PCIe switch board to replace a faulty switch board or service other components in the system.

Steps

1. Lower the PCIe switch board into the system.

 **NOTE:** Ensure that the tabs on the bottom of the PCIe switch board engage with the notches on the system.

2. Slide the PCIe switch board until the connector engages firmly with the pins on the midplane.
3. Push the levers until the PCIe switch board locks into place.
4. Tighten the two spring-loaded screws to secure the PCIe switch board to the system.

Next steps

1. Install the following:
 - PCIe modules
 - cooling-fan cage
 - cooling fans
 - system cover
2. Follow the procedure listed in [After working inside your system](#) on page 33.

Related tasks

[Installing a PCIe module](#) on page 46

[Installing the cooling-fan cage](#) on page 55

[Installing a cooling fan](#) on page 53

[Installing the system cover](#) on page 35

Related information

[Removing the PCIe switch board](#) on page 56

Fan interface board

The fan interface board is supported on the PowerEdge FX2 enclosure. The following procedure is applicable only to the FX2 enclosure.

Removing the fan interface board

Prerequisites

 **CAUTION:** Many repairs may only be done by a certified service technician. You should only perform troubleshooting and simple repairs as authorized in your product documentation, or as directed by the online or telephone service and support team. Damage due to servicing that is not authorized by Dell is not covered by your warranty. Read and follow the safety instructions that are shipped with your product.

 **NOTE:** This is a field replaceable unit (FRU). Removal and installation procedures must be performed only by Dell certified service technicians.

 **NOTE:** You must remove the fan interface board to replace a faulty board or service other components in the system.

1. Ensure that you read the [Safety instructions](#) on page 33.
2. Follow the procedure listed in [Before working inside your system](#) on page 33.
3. Remove the following:
 - system cover
 - cooling fans
 - cooling-fan cage

Steps

1. Loosen the two spring-loaded screws that secure the fan interface board to the system.
2. Holding the fan interface board by the grips, pull the fan interface board out of the system.

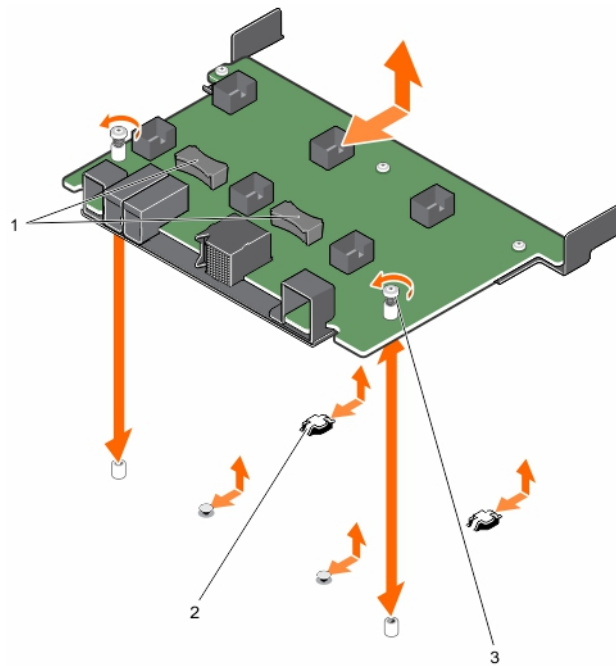

Figure 47. Removing and installing the fan interface board

- a. grip (2)
- b. notch (4)
- c. spring-loaded screw (2)

Next steps

Install the fan interface board.

Related tasks

- [Installing the fan interface board](#) on page 59
- [Removing the system cover](#) on page 34
- [Removing a cooling fan](#) on page 52
- [Removing the cooling-fan cage](#) on page 54

Installing the fan interface board

Prerequisites

CAUTION: Many repairs may only be done by a certified service technician. You should only perform troubleshooting and simple repairs as authorized in your product documentation, or as directed by the online or telephone service and support team. Damage due to servicing that is not authorized by Dell is not covered by your warranty. Read and follow the safety instructions that are shipped with your product.

NOTE: This is a field replaceable unit (FRU). Removal and installation procedures must be performed only by Dell certified service technicians.

1. Ensure that you read the [Safety instructions](#) on page 33.
2. Follow the procedure listed in [Before working inside your system](#) on page 33.
3. Remove the fan interface board.

NOTE: You must remove the fan interface board to replace a faulty board or service other components in the system.

Steps

1. Place the fan interface board in the system.

 **NOTE:** Ensure that the tabs on the back of the fan interface board engage with the notches on the system.

2. Slide the fan interface board toward the midplane until the connector engages firmly with the pins on the midplane.
3. Tighten the two spring-loaded screws to secure the fan interface board to the system.

Next steps

1. Install the following:
 - cooling-fan cage
 - cooling fans
 - system cover
2. Follow the procedure listed in [After working inside your system](#) on page 33.

Related tasks

[Installing the cooling-fan cage](#) on page 55

[Installing a cooling fan](#) on page 53

[Installing the system cover](#) on page 35

Related information

[Removing the fan interface board](#) on page 58

Interposer module

The interposer module allows you to install quarter-width sleds in the PowerEdge FX2/FX2s enclosure that comes pre-installed with half-width or full-width sleds. Your system supports up to two interposer modules.

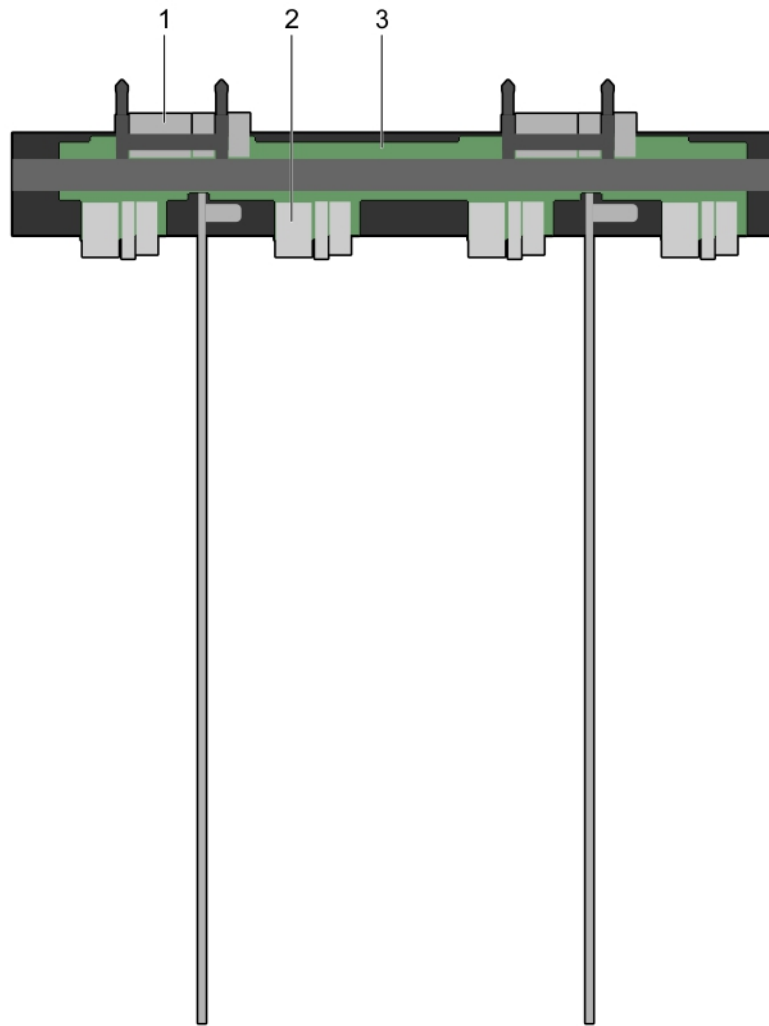

Figure 48. Top view of the interposer module

1. midplane connector (2)
2. interposer module
3. sled connector (4)

Removing the bottom interposer module

Prerequisites

CAUTION: Many repairs may only be done by a certified service technician. You should only perform troubleshooting and simple repairs as authorized in your product documentation, or as directed by the online or telephone service and support team. Damage due to servicing that is not authorized by Dell is not covered by your warranty. Read and follow the safety instructions that came with the product.

NOTE: This is a field replaceable unit (FRU). Removal and installation procedures must be performed only by Dell certified service technicians.

NOTE: You must remove the bottom interposer module to replace a faulty module, install half-width or full-width sleds, or service other components inside the system.

1. Ensure that you read the [Safety instructions](#) on page 33.
2. Follow the procedure listed in [Before working inside your system](#) on page 33.
3. Remove the following:
 - sleds
 - power supplies

- CMC module
- I/O module(s)
- PCIe modules, if applicable
- system cover
- cooling fans
- cooling-fan cage

Steps

1. Turn the system over with the bottom side of the system facing up.
2. From the bottom of the system:
 - a. Remove the five screws that secure the bottom partition.

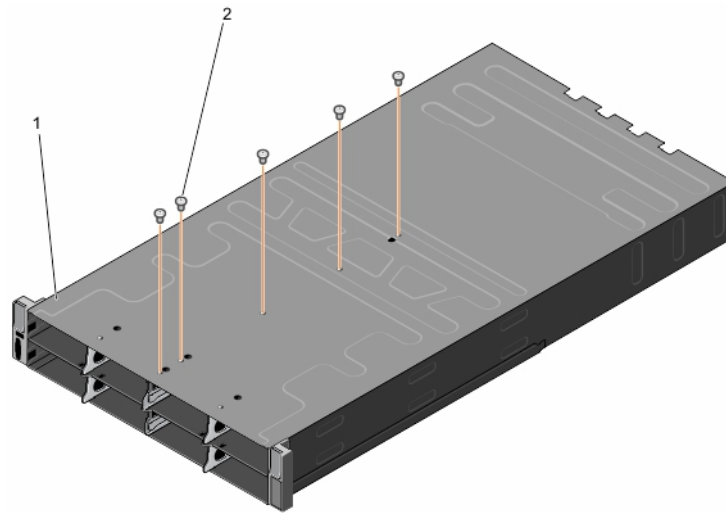

Figure 49. Removing and installing screws securing the bottom partition

- i. bottom of the system
 - ii. screw (5)
- b. Remove the two screws that secure the bottom interposer module.

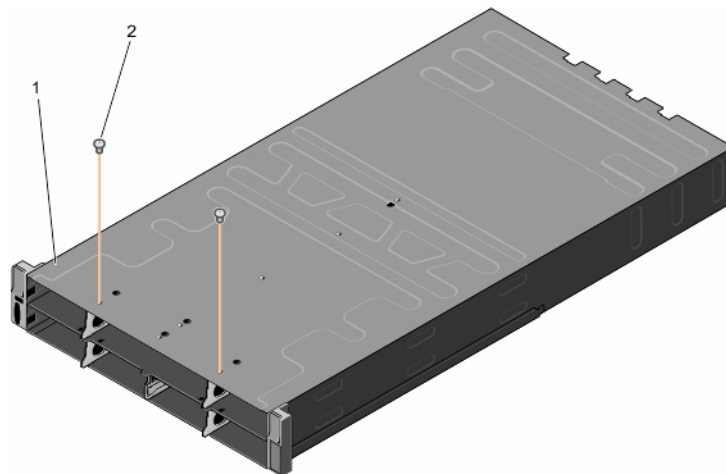

Figure 50. Removing and installing screws securing the bottom interposer module

- i. bottom of the system
 - ii. screw (2)
3. Turn the system over with the top side of the system facing up.
 4. Remove the two screws that secure the bottom partition to the top of the system.
 5. Slide the bottom partition out of the system.

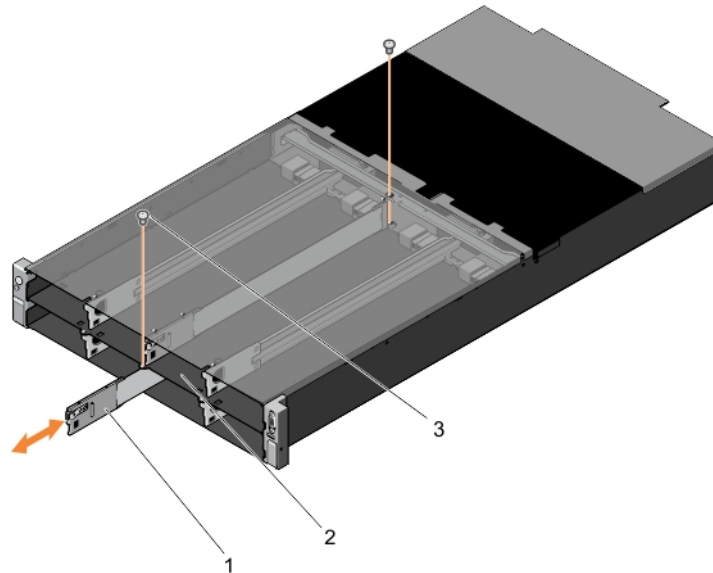

Figure 51. Removing and installing the bottom partition

- a. bottom partition
- b. screw (2)

6. Remove the two screws that secure the bottom interposer module to the top of the system.
7. Pull out the bottom interposer module from the system.

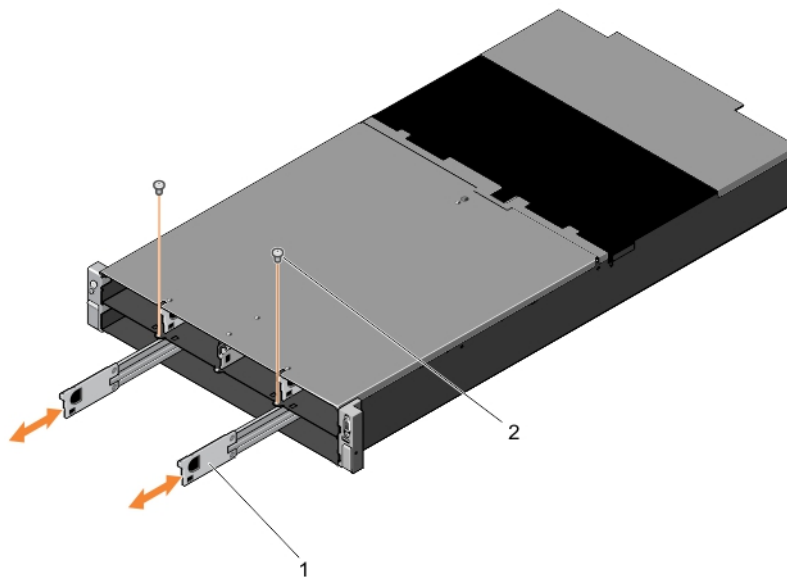

Figure 52. Removing and installing the bottom interposer module

- a. bottom interposer module (2)
- b. screw (2)

Next steps

Install the bottom interposer module.

Related tasks

[Installing the bottom interposer module](#) on page 64

[Removing a compute sled](#) on page 35

[Removing a storage sled](#) on page 37

[Removing a power supply unit](#) on page 50

- [Removing the CMC module](#) on page 42
- [Removing an I/O module](#) on page 44
- [Removing a PCIe module](#) on page 45
- [Removing the system cover](#) on page 34
- [Removing a cooling fan](#) on page 52
- [Removing the cooling-fan cage](#) on page 54

Installing the bottom interposer module

Prerequisites

CAUTION: Many repairs may only be done by a certified service technician. You should only perform troubleshooting and simple repairs as authorized in your product documentation, or as directed by the online or telephone service and support team. Damage due to servicing that is not authorized by Dell is not covered by your warranty. Read and follow the safety instructions that came with the product.

NOTE: This is a field replaceable unit (FRU). Removal and installation procedures must be performed only by Dell certified service technicians.

1. Ensure that you read the [Safety instructions](#) on page 33.
2. Follow the procedure listed in [Before working inside your system](#) on page 33.
3. Remove the bottom interposer module.

NOTE: You must remove the bottom interposer module to replace a faulty module, install half-width or full-width sleds, or service other components inside the system.

Steps

1. Slide the bottom interposer module into the lower bay of the system until the pins on the interposer module engage with the connectors on the midplane.
2. Install the two screws that secure the bottom interposer module to the top of the system.
3. Slide the bottom partition into the lower bay of the system.
4. Install the two screws that secure the bottom partition to the top of the system.
5. Turn the system over with the bottom side of the system facing up.
6. Install the five screws to secure the bottom partition to the bottom of the system.
7. Install the two screws to secure the bottom partition to the bottom of the system.
8. Turn the system over with the top side of the system facing up.

Next steps

1. Install the following:
 - cooling-fan cage
 - cooling fans
 - system cover
 - PCIe modules, if applicable
 - I/O module(s)
 - CMC module
 - power supplies
 - sleds
2. Follow the procedure listed in [After working inside your system](#) on page 33.

Related tasks

- [Installing the cooling-fan cage](#) on page 55
- [Installing a cooling fan](#) on page 53
- [Installing the system cover](#) on page 35
- [Installing a PCIe module](#) on page 46
- [Installing an I/O module](#) on page 44
- [Installing the CMC module](#) on page 42

[Installing a power supply unit](#) on page 51

[Installing a storage sled](#) on page 39

[Installing a compute sled](#) on page 36

Related information

[Removing the bottom interposer module](#) on page 61

Removing the top interposer module

Prerequisites

CAUTION: Many repairs may only be done by a certified service technician. You should only perform troubleshooting and simple repairs as authorized in your product documentation, or as directed by the online or telephone service and support team. Damage due to servicing that is not authorized by Dell is not covered by your warranty. Read and follow the safety instructions that came with the product.

NOTE: This is a field replaceable unit (FRU). Removal and installation procedures must be performed only by Dell certified service technicians.

NOTE: You must remove the top interposer module to replace a faulty module, install half-width or full-width sleds, or service other components inside the system.

NOTE: You must remove the bottom interposer module before removing the top interposer module.

1. Ensure that you read the [Safety instructions](#) on page 33.
2. Follow the procedure listed in [Before working inside your system](#) on page 33.
3. Remove the following:
 - sleds
 - power supplies
 - CMC module
 - I/O module(s)
 - PCIe modules, if applicable
 - system cover
 - cooling fans
 - cooling-fan cage
 - bottom interposer module

Steps

1. Turn the system over with the bottom side of the system facing up.
2. From the bottom of the system:
 - a. Remove the three screws that secure the top partition to the middle plate.

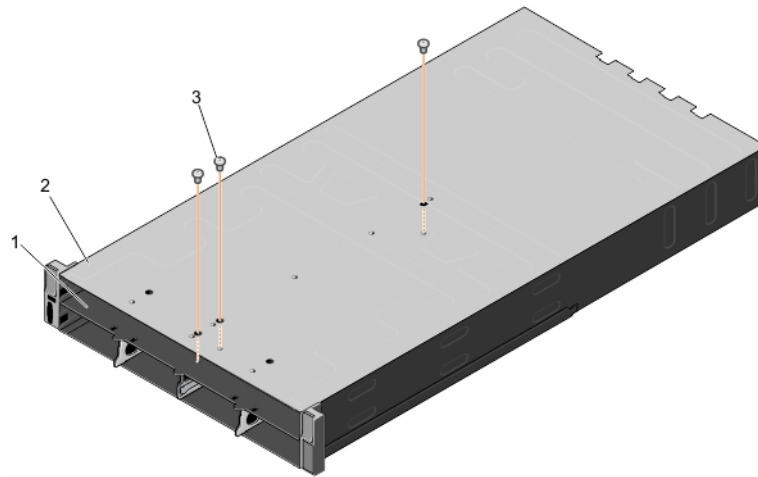

Figure 53. Removing and installing screws securing the top partition to the middle plate

- i. middle plate
- ii. bottom of the system
- iii. screw (3)

b. Remove the two screws that secure the top interposer module to the middle plate.

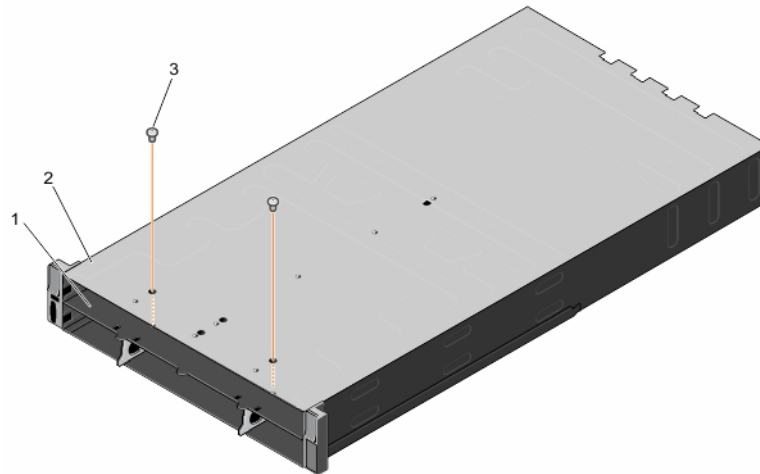

Figure 54. Removing and installing screws securing the top interposer module to the middle plate

- i. middle plate
- ii. bottom of the system
- iii. screw (2)

3. Turn the system over with the top side of the system facing up.
4. Remove the three screws that secure the top partition to the top of the system.
5. Slide the top partition out of the system.

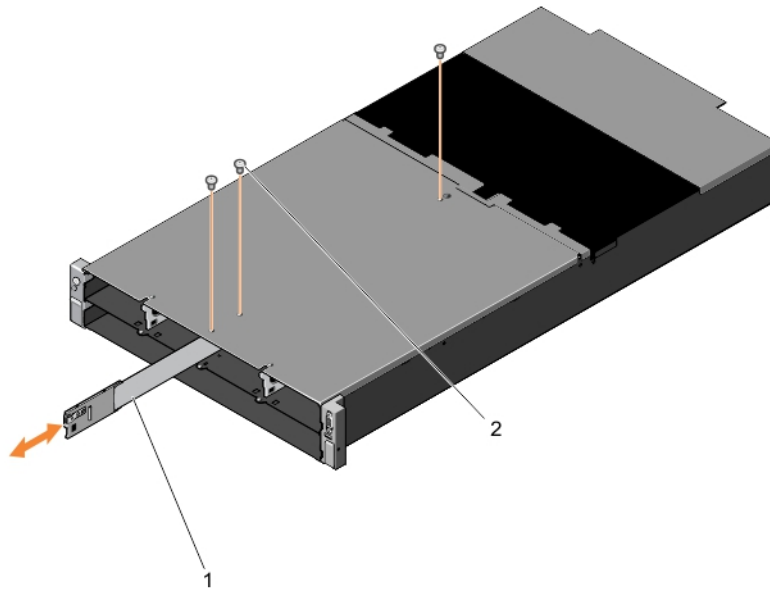

Figure 55. Removing and installing the top partition

- a. top partition
- b. screw (3)

6. Remove the two screws that secure the top interposer module to the top of the system.
7. Pull out the top interposer module from the system.

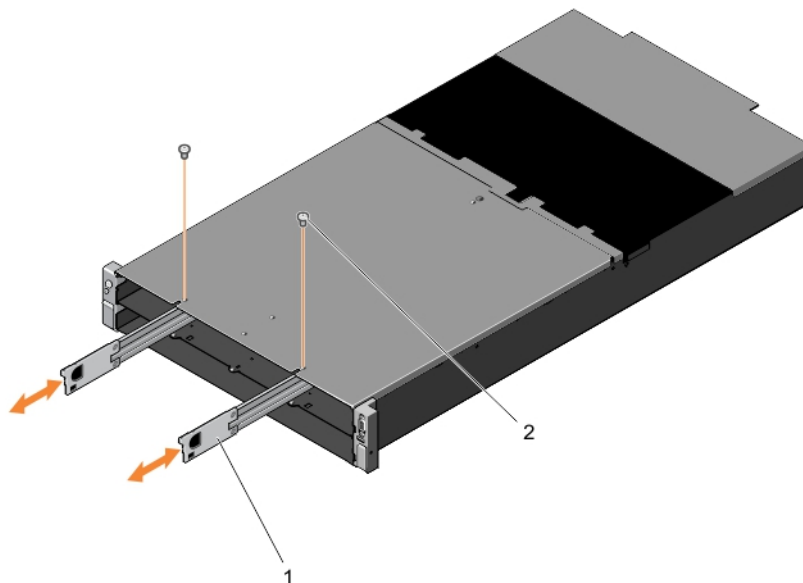

Figure 56. Removing and installing the top interposer module

- a. top interposer module
- b. screw (2)

Next steps

Install the top interposer module.

Related tasks

- [Installing the top interposer module](#) on page 68
- [Removing a compute sled](#) on page 35
- [Removing a storage sled](#) on page 37
- [Removing a power supply unit](#) on page 50

- [Removing the CMC module](#) on page 42
- [Removing an I/O module](#) on page 44
- [Removing a PCIe module](#) on page 45
- [Removing the system cover](#) on page 34
- [Removing a cooling fan](#) on page 52
- [Removing the cooling-fan cage](#) on page 54
- [Removing the bottom interposer module](#) on page 61

Installing the top interposer module

Prerequisites

CAUTION: Many repairs may only be done by a certified service technician. You should only perform troubleshooting and simple repairs as authorized in your product documentation, or as directed by the online or telephone service and support team. Damage due to servicing that is not authorized by Dell is not covered by your warranty. Read and follow the safety instructions that came with the product.

NOTE: This is a field replaceable unit (FRU). Removal and installation procedures must be performed only by Dell certified service technicians.

1. Ensure that you read the [Safety instructions](#) on page 33.
2. Follow the procedure listed in [Before working inside your system](#) on page 33.
3. Remove the top interposer module.

NOTE: You must remove the top interposer module to replace a faulty module, install half-width or full-width sleds, or service other components inside the system.

Steps

1. Slide the top interposer module into the upper bay of the system until the pins on the interposer module engage with the connectors on the midplane.
2. Install the two screws to secure the top interposer module to the top of the system.
3. Slide the top partition into the system.
4. Install the three screws to secure the top partition to the top of the system.
5. Turn the system over with the bottom side of the system facing up.
6. Install the two screws to secure the top interposer module to the middle plate.
7. Install the three screws to secure the top partition to the middle plate.
8. Turn the system over with the top side of the system facing up.

Next steps

1. Install the following:
 - bottom interposer module
 - cooling-fan cage
 - cooling fans
 - system cover
 - PCIe modules, if applicable
 - I/O module(s)
 - CMC module
 - power supplies
 - sleds
2. Follow the procedure listed in [After working inside your system](#) on page 33.

Related tasks

- [Installing the bottom interposer module](#) on page 64
- [Installing the cooling-fan cage](#) on page 55
- [Installing a cooling fan](#) on page 53
- [Installing the system cover](#) on page 35

- [Installing a PCIe module](#) on page 46
- [Installing an I/O module](#) on page 44
- [Installing the CMC module](#) on page 42
- [Installing a power supply unit](#) on page 51
- [Installing a storage sled](#) on page 39
- [Installing a compute sled](#) on page 36

Related information

- [Removing the top interposer module](#) on page 65

Midplane assembly

The midplane assembly includes the midplane, power interposer board, power cable, and bus bar.

Removing the midplane assembly

Prerequisites

CAUTION: Many repairs may only be done by a certified service technician. You should only perform troubleshooting and simple repairs as authorized in your product documentation, or as directed by the online or telephone service and support team. Damage due to servicing that is not authorized by Dell is not covered by your warranty. Read and follow the safety instructions that came with the product.

NOTE: This is a field replaceable unit (FRU). Removal and installation procedures should be performed only by Dell certified service technicians.

NOTE: You must remove the midplane assembly to replace a faulty assembly.

1. Ensure that you read the [Safety instructions](#) on page 33.
2. Follow the procedure listed in [Before working inside your system](#) on page 33.
3. Remove the following:
 - sleds
 - power supplies
 - CMC module
 - I/O module(s)
 - system cover
 - cooling fans
 - cooling-fan cage
 - PCIe modules and PCIe switch board, if applicable
 - fan interface board, if applicable
 - interposer module(s), if applicable

Steps

1. Lift the Mylar insulator from the midplane.
2. Remove the two fan cables connected to the midplane.
3. Remove the two screws that secure the fan cable clips to the system.

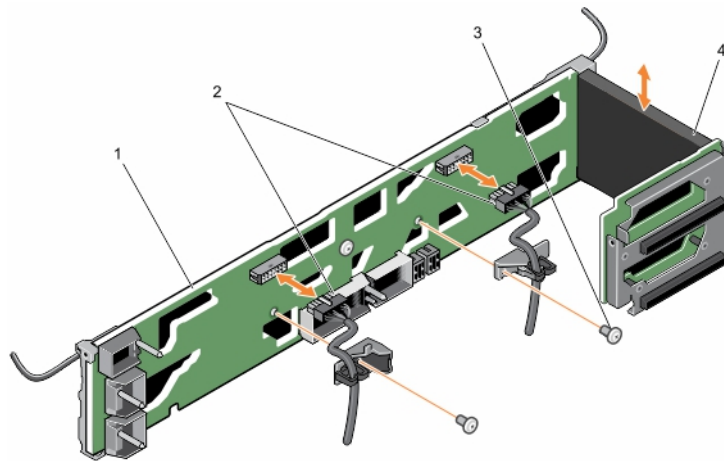

Figure 57. Removing and installing midplane assembly components

- | | |
|--------------|-----------------------|
| 1. midplane | 2. fan-cable clip (2) |
| 3. screw (2) | 4. Mylar insulator |

4. Remove the five screws that secure the midplane assembly to the system.

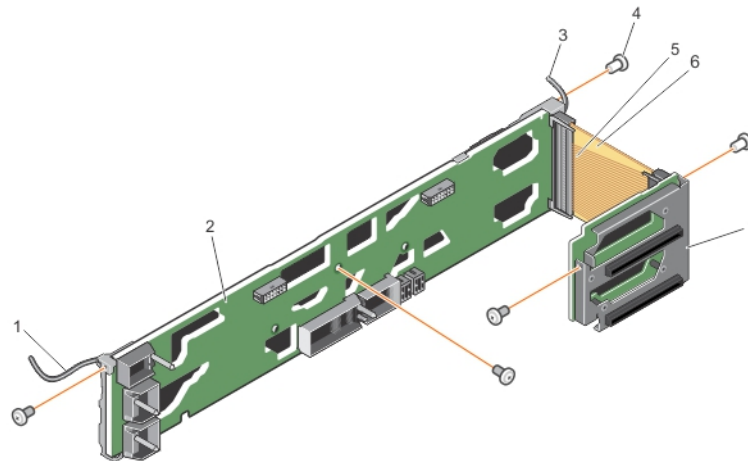

Figure 58. Removing and installing the midplane

- | | |
|---------------------------|--------------------------------|
| 1. KVM cable | 2. midplane |
| 3. control panel cable | 4. midplane assembly screw (5) |
| 5. cable cover | 6. power bus bar |
| 7. power interposer board | |

5. Remove the screws that secure the cable tube on the left side of the chassis.
6. Remove the control panel cable from the cable tube.
7. Remove the screws on the front of the KVM panel that secure the KVM panel board.
8. Remove the screws that secure the KVM cover.
9. Remove the screws that secure the cable tube on the right side of the chassis.
10. Place the cable tube on the chassis without removing the KVM panel cable and the KVM panel.
11. Lift the midplane assembly from the system and place it on top of the chassis.

NOTE: Exercise care when removing midplane assembly and placing it on the chassis, to prevent any damage to the KVM and control panel cables.

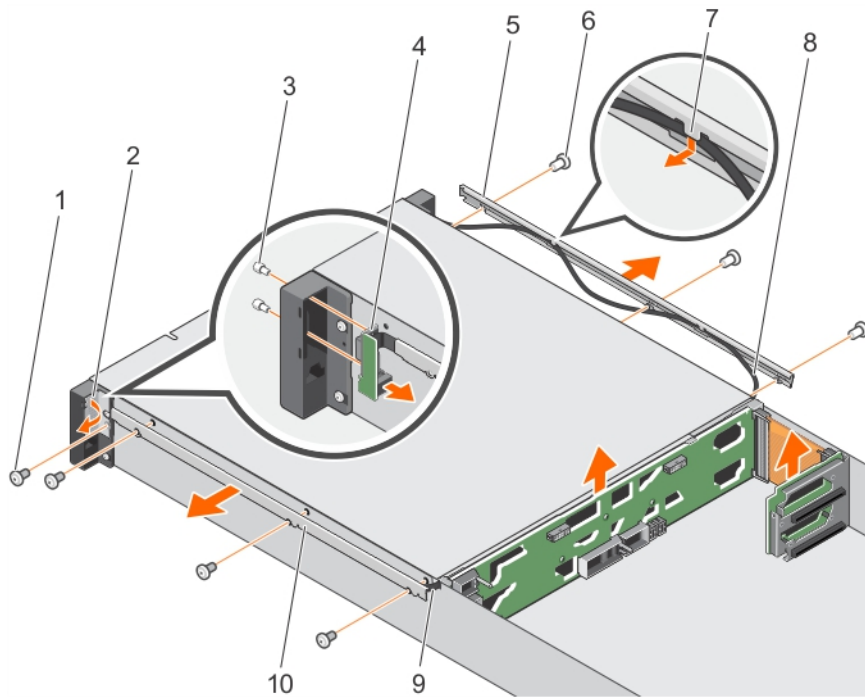

Figure 59. Removing and installing the cable tubes

- | | |
|---|---|
| 1. screw on the KVM cover | 2. KVM panel cover |
| 3. Hex screw on the KVM panel (2) | 4. KVM panel board |
| 5. cable tube on the left side of the chassis | 6. screws on the cable tubes (6) |
| 7. tabs on the cable tubes | 8. control panel cable |
| 9. KVM panel cable | 10. cable tube on the right side of the chassis |

12. Push the KVM cable latch vertically up to disconnect the cable from the connector on the midplane.
13. Disconnect the control panel cable connector from the connector on the midplane.

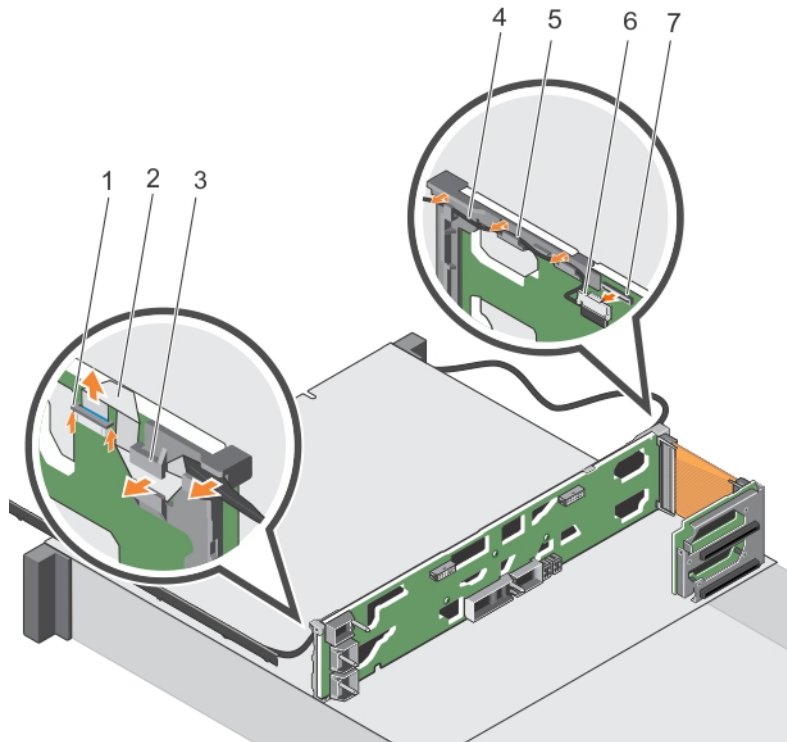

Figure 60. Routing of the KVM and control panel cables on the midplane

- | | |
|---|----------------------------------|
| 1. KVM cable connector | 2. KVM cable |
| 3. brackets on the midplane assembly to route the KVM cable | 4. control panel cable |
| 5. brackets on the midplane assembly to route the control panel cable | 6. control panel cable connector |
| 7. connector on the midplane | |

14. Lift the midplane assembly out of the system.

Next steps

1. Install the midplane assembly.

Related tasks

- [Installing the midplane assembly](#) on page 73
- [Removing a compute sled](#) on page 35
- [Removing a storage sled](#) on page 37
- [Removing a power supply unit](#) on page 50
- [Removing the CMC module](#) on page 42
- [Removing an I/O module](#) on page 44
- [Removing the system cover](#) on page 34
- [Removing a cooling fan](#) on page 52
- [Removing the cooling-fan cage](#) on page 54
- [Removing a PCIe module](#) on page 45
- [Removing the PCIe switch board](#) on page 56
- [Removing the fan interface board](#) on page 58
- [Removing the bottom interposer module](#) on page 61
- [Removing the top interposer module](#) on page 65

Installing the midplane assembly

Prerequisites

CAUTION: Many repairs may only be done by a certified service technician. You should only perform troubleshooting and simple repairs as authorized in your product documentation, or as directed by the online or telephone service and support team. Damage due to servicing that is not authorized by Dell is not covered by your warranty. Read and follow the safety instructions that came with the product.

NOTE: This is a field replaceable unit (FRU). Removal and installation procedures should be performed only by Dell certified service technicians.

1. Ensure that you read the [Safety instructions](#) on page 33.
2. Follow the procedure listed in [Before working inside your system](#) on page 33.
3. Remove the midplane assembly.

NOTE: You must remove the midplane assembly to replace a faulty assembly.

Steps

1. Route the KVM and control panel cables in the brackets on the midplane assembly.
2. Reconnect the KVM and control panel cables to the respective connectors on the midplane assembly.
3. Place the midplane assembly in the system.
4. Install the five screws to secure the midplane assembly to the system.
5. Install the two screws to secure the fan-cable clips to the system.
6. Reconnect the two fan cables to the midplane assembly.
7. Secure the fan cables by inserting the cables in fan cable clips.
8. Reconnect the KVM cable connector to the connector in the KVM panel.
9. Install the screws to secure the cable tube and KVM panel cover on the right side of the chassis.
10. Install the screws to secure the cable tube on the left side of the chassis.

Next steps

1. Install the following:
 - interposer module(s)
 - fan interface board, if applicable
 - PCIe modules and PCIe switch board, if applicable
 - cooling-fan cage
 - cooling fans
 - system cover
 - I/O module(s)
 - CMC module
 - power supplies
 - sleds
2. Follow the procedure listed in [After working inside your system](#) on page 33.

Related tasks

[Installing the top interposer module](#) on page 68

[Installing the bottom interposer module](#) on page 64

[Installing the fan interface board](#) on page 59

[Installing the PCIe switch board](#) on page 57

[Installing a PCIe module](#) on page 46

[Installing the cooling-fan cage](#) on page 55

[Installing a cooling fan](#) on page 53

[Installing the system cover](#) on page 35

[Installing an I/O module](#) on page 44

[Installing the CMC module](#) on page 42

[Installing a power supply unit](#) on page 51

Installing a storage sled on page 39
Installing a compute sled on page 36

Related information

Removing the midplane assembly on page 69

Power interposer board

Removing the power interposer board

Prerequisites

CAUTION: Many repairs may only be done by a certified service technician. You should only perform troubleshooting and simple repairs as authorized in your product documentation, or as directed by the online or telephone service and support team. Damage due to servicing that is not authorized by Dell is not covered by your warranty. Read and follow the safety instructions that came with the product.

NOTE: This is a field replaceable unit (FRU). Removal and installation procedures should be performed only by Dell certified service technicians.

1. Ensure that you read the [Safety instructions](#) on page 33.
2. Follow the procedure listed in [Before working inside your system](#) on page 33.
3. Remove the midplane assembly.

Steps

1. Remove the Mylar insulator.
2. Disconnect the power bus bar and the cable cover from the midplane assembly.
3. Disconnect the power bus bar and the cable cover from the power interposer board.
4. Remove the four screws that secure the power interposer board to the carrier.
5. Lift the power interposer board from the carrier.

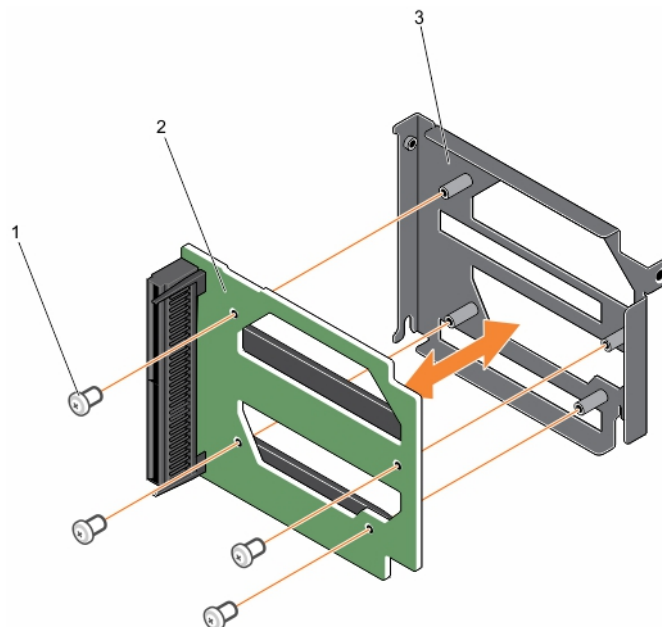

Figure 61. Removing and installing the power interposer board

- a. screw (4)
- b. power interposer board
- c. carrier

Next steps

Install the power interposer board.

Installing the power interposer board

Prerequisites

 **CAUTION:** Many repairs may only be done by a certified service technician. You should only perform troubleshooting and simple repairs as authorized in your product documentation, or as directed by the online or telephone service and support team. Damage due to servicing that is not authorized by Dell is not covered by your warranty. Read and follow the safety instructions that came with the product.

 **NOTE:** This is a field replaceable unit (FRU). Removal and installation procedures should be performed only by Dell certified service technicians.

1. Ensure that you read the [Safety instructions](#) on page 33.
2. Follow the procedure listed in [Before working inside your system](#) on page 33.
3. Remove the power interposer board.

 **NOTE:** You must remove the power interposer board to replace a faulty power interposer board.

Steps

1. Place the power interposer board in the carrier.
2. Install the four screws to secure the power interposer board to the carrier.
3. Reconnect the power bus bar and cable cover to the power interposer board.
4. Reconnect the power bus bar and cable cover to the midplane assembly.
5. Install the Mylar insulator.

Next steps

1. Install the midplane assembly.
2. Follow the procedure listed in [After working inside your system](#) on page 33.

Control panel

Removing the control panel

Prerequisites

 **CAUTION:** Many repairs may only be done by a certified service technician. You should only perform troubleshooting and simple repairs as authorized in your product documentation, or as directed by the online or telephone service and support team. Damage due to servicing that is not authorized by Dell is not covered by your warranty. Read and follow the safety instructions that came with the product.

 **NOTE:** This is a field replaceable unit (FRU). Removal and installation procedures must be performed only by Dell certified service technicians.

 **NOTE:** You must remove the control panel to replace a faulty control panel.

1. Ensure that you read the [Safety instructions](#) on page 33.
2. Follow the procedure listed in [Before working inside your system](#) on page 33.

Steps

1. Remove the three screws that secure the cable tube to the side of the system and remove the cable tube.
2. Remove the two screws that secure the control panel to the system.

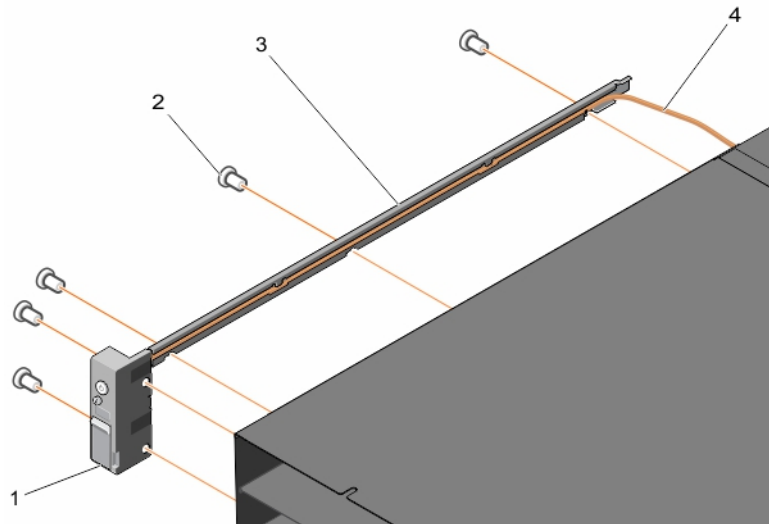

Figure 62. Removing and installing the cable tube

- | | |
|------------------|------------------------|
| 1. control panel | 2. screw (5) |
| 3. cable tube | 4. control panel cable |

3. Remove the screw that secures the control panel cover to the control panel.
4. Release the ZIF connector latch.
5. Using the pull-tab, remove the control panel cable from the control panel.

NOTE: To prevent damage to the control panel cable, exercise utmost care when removing the control panel cable from the control panel.

6. Remove the control panel from the system.

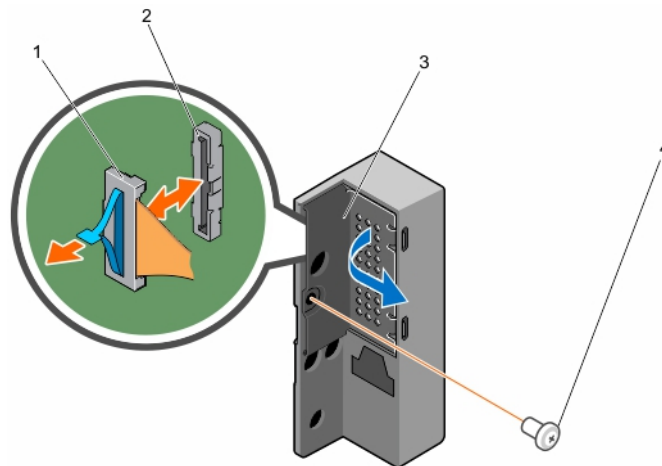

Figure 63. Removing and installing the control panel

- | | |
|------------------------|--------------|
| 1. ZIF connector latch | 2. connector |
| 3. control panel cover | 4. screw |

Next steps

Install the control panel.

Related tasks

[Installing the control panel](#) on page 77

Installing the control panel

Prerequisites

CAUTION: Many repairs may only be done by a certified service technician. You should only perform troubleshooting and simple repairs as authorized in your product documentation, or as directed by the online or telephone service and support team. Damage due to servicing that is not authorized by Dell is not covered by your warranty. Read and follow the safety instructions that came with the product.

NOTE: This is a field replaceable unit (FRU). Removal and installation procedures must be performed only by Dell certified service technicians.

1. Ensure that you read the [Safety instructions](#) on page 33.
2. Follow the procedure listed in [Before working inside your system](#) on page 33.
3. Remove the control panel.

NOTE: You must remove the control panel to replace a faulty control panel.

Steps

1. Connect the control panel cable to the control panel.
2. Press the ZIF connector release latch into place.
3. Install the screw to secure the control panel cover to the control panel.
4. Align the screw holes on the control panel with the screw holes on the side of the system.
5. Install the two screws to secure the control panel to the side of the system.
6. Insert the control panel cable in the cable tube.
7. Align the screw holes on the cable tube with the screw holes on the side of the system.
8. Install the three screws to secure the cable tube to the side of the system.

Next steps

Follow the procedure listed in [After working inside your system](#) on page 33.

Related information

[Removing the control panel](#) on page 75

KVM panel

Removing the KVM panel

Prerequisites

CAUTION: Many repairs may only be done by a certified service technician. You should only perform troubleshooting and simple repairs as authorized in your product documentation, or as directed by the online or telephone service and support team. Damage due to servicing that is not authorized by Dell is not covered by your warranty. Read and follow the safety instructions that came with the product.

NOTE: This is a field replaceable unit (FRU). Removal and installation procedures must be performed only by Dell certified service technicians.

NOTE: You must remove the KVM panel to replace a faulty panel.

1. Ensure that you read the [Safety instructions](#) on page 33.
2. Follow the procedure listed in [Before working inside your system](#) on page 33.

Steps

1. Remove the three screws that secure the cable tube to the side of the system and remove the cable tube.

- Remove the two screws that secure the KVM panel to the system.

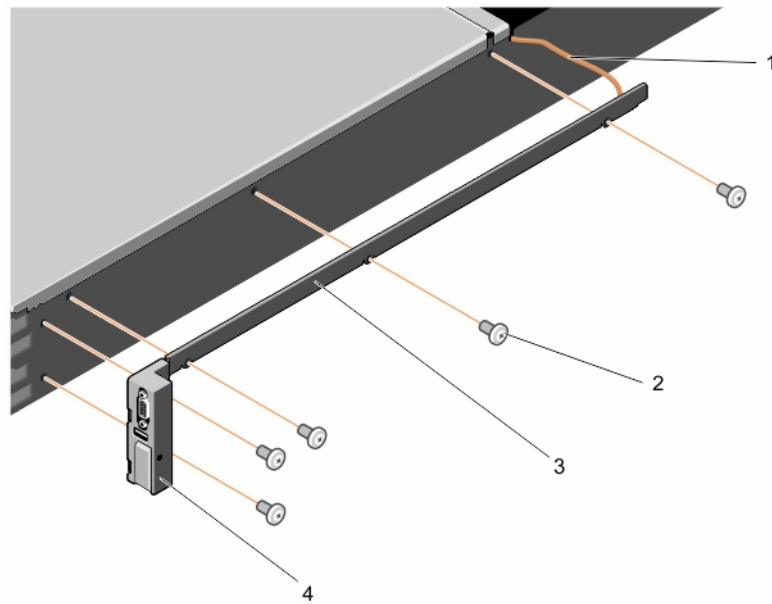

Figure 64. Removing and installing the cable tube

- | | |
|--------------------|--------------|
| 1. KVM panel cable | 2. screw (5) |
| 3. cable tube | 4. KVM panel |

- Remove the screw that secures the KVM panel cover to the KVM panel.
- Release the connector latch.
- Remove the KVM panel cable from the KVM panel.

NOTE: To prevent damage to the KVM panel cable, exercise utmost care when removing the KVM panel cable from the KVM panel.

- Remove the KVM panel.

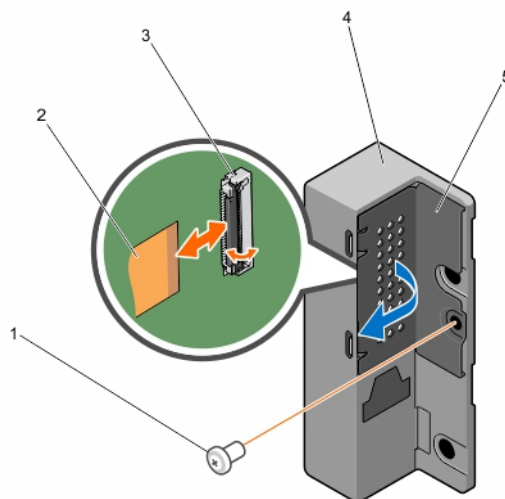

Figure 65. Removing and installing the KVM panel

- | | |
|--------------------|--------------------|
| 1. screw | 2. KVM panel cable |
| 3. connector | 4. KVM panel |
| 5. KVM panel cover | |

Next steps

Install the KVM panel.

Related tasks

[Installing the KVM panel](#) on page 79

Installing the KVM panel

Prerequisites

 **CAUTION:** Many repairs may only be done by a certified service technician. You should only perform troubleshooting and simple repairs as authorized in your product documentation, or as directed by the online or telephone service and support team. Damage due to servicing that is not authorized by Dell is not covered by your warranty. Read and follow the safety instructions that came with the product.

 **NOTE:** This is a field replaceable unit (FRU). Removal and installation procedures must be performed only by Dell certified service technicians.

1. Ensure that you read the [Safety instructions](#) on page 33.
2. Follow the procedure listed in [Before working inside your system](#) on page 33.
3. Remove the KVM panel.

 **NOTE:** You must remove the KVM panel to replace a faulty panel.

Steps

1. Connect the KVM panel cable to the KVM panel.
2. Press the connector latch into place.
3. Install the screw to secure the KVM panel cover to the KVM panel.
4. Align the screw holes on the KVM panel with the screw holes on the side of the system.
5. Install the two screws to secure the KVM panel to the side of the system.
6. Insert the KVM panel cable in the cable tube.
7. Align the screw holes on the cable tube with the screw holes on the side of the system.
8. Install the three screws to secure the cable tube to the side of the system.

Next steps

Follow the procedure listed in [After working inside your system](#) on page 33.

Related information

[Removing the KVM panel](#) on page 77

Troubleshooting your system

 **NOTE:** This chapter provides troubleshooting information for the PowerEdge FX2 and FX2s enclosures only. For troubleshooting information on the sleds, see the sled documentation at Dell.com/poweredgemanuals.

Safety first—for you and your system

 **CAUTION:** Many repairs may only be done by a certified service technician. You should only perform troubleshooting and simple repairs as authorized in your product documentation, or as directed by the online or telephone service and support team. Damage due to servicing that is not authorized by Dell is not covered by your warranty. Read and follow the safety instructions that are shipped with your product.

Topics:

- [Responding to a systems management alert message](#)
- [Troubleshooting external connections](#)
- [Troubleshooting a damaged enclosure](#)
- [Troubleshooting enclosure components](#)
- [Troubleshooting I/O modules](#)

Responding to a systems management alert message

The Chassis Management Controller (CMC) management applications monitor critical system voltages and temperatures, and the cooling fans in the system. For information about the CMC alert messages, see the Dell PowerEdge FX2 CMC User's Guide at Dell.com/esmmanuals.

Troubleshooting external connections

Ensure that all external cables are securely attached to the external connectors on your system before troubleshooting any external devices.

Troubleshooting a damaged enclosure

Steps

1. Ensure that the following components are properly installed and connected:
 - Sleds
 - Power supplies
 - I/O module
 - Cooling fans
 - Cooling-fan bay
 - CMC module
 - Expansion cards
 - Midplane assembly
2. Ensure that all cables are properly connected.
3. Ensure that all components are properly installed and free from damage.
4. Run the online diagnostics.

If the tests fail, see [Getting Help](#).

Troubleshooting enclosure components

The following procedures describe how to troubleshoot the enclosure components.

Troubleshooting a wet enclosure

Prerequisites

 **CAUTION:** Many repairs may only be done by a certified service technician. You should only perform troubleshooting and simple repairs as authorized in your product documentation, or as directed by the online or telephone service and support team. Damage due to servicing that is not authorized by Dell is not covered by your warranty. Read and follow the safety instructions that are shipped with your product.

Steps

1. Turn off the system and attached peripherals.
2. Disconnect the power supplies from the PDU or electrical outlet.

 **CAUTION:** Wait until all of the indicators on the power supplies turn off before proceeding.

3. Remove the following components from the system:
 - a. Sleds
 - b. Power supplies
 - c. I/O modules
 - d. Cooling fans
 - e. Cooling-fan bay
 - f. CMC module
 - g. PCIe modules

 **CAUTION:** Air dry and do not use towels.

4. Let the system dry thoroughly for at least 24 hours.
5. Reinstall the components you removed in step 3.
6. Reconnect the power supplies to the PDU or electrical outlet and start up the system.
If the system does not start up properly, see [Getting Help](#).

Troubleshooting power supply units

Prerequisites

 **CAUTION:** The power supply units (PSUs) are hot swappable. Remove and replace only one PSU at a time in a system that is turned on. Leave a failed PSU installed in the enclosure until you are ready to replace it. Operating the system with a PSU removed for extended periods of time can cause the system to overheat.

 **NOTE:** Ensure that all PSUs are of the same rated output capacity, generation, and input voltage.

 **NOTE:** The FX2 chassis supports only PSUs with a rated output capacity of 1100 W, 1600 W, 2000 W, or 2400 W.

Steps

1. Locate the faulty PSU and check the indicators. The AC indicator on the PSU is green if AC power is available. The fault indicator on the PSU is amber if the PSU is faulty. If no indicators are lit, ensure that AC power is available from the PDU or electrical outlet, and the power cable is properly connected to the PSU.
2. Reseat the PSU by removing and reinstalling it.

NOTE: After installing a PSU, allow several seconds for the system to recognize the PSU and determine whether it is working properly.

3. If the problem is not resolved, swap or replace the PSU with a known good PSU.
4. If none of the power supplies show a fault LED and the sleds do not power on, check the CMC for status messages. For more information, see the Dell PowerEdge FX2 CMC User's Guide at [Dell.com/esmmanuals](https://www.dell.com/esmmanuals).
5. If the problem persists, see [Getting Help](#).

Troubleshooting power supply unit mismatch

The PowerEdge FX2 chassis unit supports various power supply unit (PSU) models. Instances of PSU mismatch may occur when mixing different PSU models in a system configuration.

Steps

1. The system checks for a PSU mismatch following an AC power cycle or when a replacement PSU is connected.
2. The LED indicator in the handle of the PSU flashes green several times then turns off, this sequence indicates that there is a PSU mismatch.

NOTE: A critical alert message is generated in the chassis management controller (CMC) logs. The log provides information on the PSU redundancy status and the log also indicates if the PSU is incompatible with the other installed PSUs.

3. Replace the incompatible PSU with a known good PSU.
4. If the problem persists, see [Getting Help](#).

Troubleshooting cooling problems

CAUTION: Many repairs may only be done by a certified service technician. You should only perform troubleshooting and simple repairs as authorized in your product documentation, or as directed by the online or telephone service and support team. Damage due to servicing that is not authorized by Dell is not covered by your warranty. Read and follow the safety instructions that are shipped with your product.

Ensure that the following conditions exist:

- System cover, sled blank(s), or expansion-card filler bracket(s) is not removed.
- Ambient temperature is not too high.
- External airflow is not obstructed.

NOTE: To maintain optimum thermal conditions, ensure that there are no obstructions to airflow on the front and back of the enclosure. The front and back of the enclosure must have at least 30 cm (12 inches) and 61 cm (24 inches) of unobstructed space respectively.

- A cooling fan is not removed or has not failed.
- The expansion card installation guidelines are followed.

Troubleshooting cooling fans

Prerequisites

CAUTION: The power supply units (PSUs) are hot swappable. Remove and replace only one PSU at a time in a system that is turned on. Leave a failed PSU installed in the enclosure until you are ready to replace it. Operating the system with a PSU removed for extended periods of time can cause the system to overheat.

Steps

1. Log in to the CMC web interface and identify the faulty fan. For more information, see the Dell PowerEdge FX2 CMC User's Guide at [Dell.com/esmmanuals](https://www.dell.com/esmmanuals).
2. Open the system. See [Opening The System](#).
3. Reseat the fan.
4. If the fan functions properly, close the system.

5. If the fan is faulty, install a new fan.
6. Close the system.

If the replacement fan does not operate, see [Getting Help](#).

Troubleshooting expansion cards

Prerequisites

CAUTION: Many repairs may only be done by a certified service technician. You should only perform troubleshooting and simple repairs as authorized in your product documentation, or as directed by the online or telephone service and support team. Damage due to servicing that is not authorized by Dell is not covered by your warranty. Read and follow the safety instructions that are shipped with your product.

NOTE: When troubleshooting an expansion card, see the documentation for your operating system and the expansion card.

Steps

1. Run the appropriate diagnostic test from the sled.
If the test fails, go to step 3.
2. Log in to the CMC web interface.
3. In the PCIe properties verify if the PCIe slots are assigned to the sleds.
For more information, see the Dell PowerEdge FX2 CMC User's Guide at Dell.com/esmmanuals.
4. Turn off the sleds.
5. Turn off the system and attached peripherals, and disconnect the system from the electrical outlet.
6. Remove the PCIe module.
7. Ensure that each expansion card is firmly seated in its connector.
8. Reinstall the PCIe module.
9. If the problem is not resolved, turn off the system and attached peripherals, and disconnect the system from the electrical outlet.
10. Remove the PCIe modules.
11. Remove all expansion cards installed in the system.
12. Reinstall the PCIe modules.
13. Run the appropriate diagnostic test from the sled.
If the tests fail, see [Getting Help](#).
14. For each expansion card you removed in step 11, perform the following steps:
 - a. Turn off the system and attached peripherals, and disconnect the system from the electrical outlet.
 - b. Remove the PCIe module.
 - c. Reinstall the expansion card.
 - d. Reinstall the PCIe module.
 - e. Run the appropriate diagnostic test.

Next steps

If a problem is still indicated, see [Getting Help](#).

Troubleshooting I/O modules

Prerequisites

NOTE: To eliminate the possibility of a hardware problem with an I/O module or devices connected to the module, ensure that the module is properly initialized and configured.

Steps

1. Check that the pass-through module or switch ports are cabled correctly.

2. Ensure that the network daughter cards/LOM cards on the sleds are mapped to the I/O module.
3. Verify that the switch or pass-through module is fully booted, and verify the firmware revision and IP address of the switch or pass-through module.
4. Verify that the switch or pass-through module has a valid IP address for the subnet. Verify by using the ICMP `ping` command.
5. Check the network connector indicators on the network switch module:
 - If the link indicator displays an error condition, check all cable connections.
 - Try another connector on the external switch or hub.
 - If the activity indicator does not light, replace the network switch module.
6. Using the switch management interface, verify the switch port properties. If the switch is configured correctly, back up the switch configuration and replace the switch. See the switch module documentation for details.
7. Ensure that the appropriate Network Daughter Card(s) (NDC) are installed in the sled(s). If the network link indicator on the sled is green, then the sled has a valid link to the I/O module.
8. Ensure that the appropriate operating system drivers are installed and that the protocol settings are configured to ensure proper communication.

Technical specifications—PowerEdge FX2/ FX2s

Dimensions and weight

Physical	Dimensions
Width	With rack ears 481.9 mm (18.97 in)
	Without rack ears 43.35 cm (17.06 inch)
Height	86.80 mm (3.4 in)
Depth (without bezel)	851.6 mm (33.52 in)
Maximum configuration weight	53 kg (116.8 lb)
Empty weight	21.5 kg (47.4 lb)

Sled specifications

Compute sleds Specifications

PowerEdge FX2	Up to four half-width PowerEdge FC630/FC640 or PowerEdge FM120x4 compute sleds, or Up to eight PowerEdge FC430 compute sleds, or Up to two PowerEdge FC830 compute sleds, or Up to four PowerEdge FC430 compute sleds mixed with up to two PowerEdge FC630/FC640 compute sleds, or One PowerEdge FC830 compute sled mixed with up to two PowerEdge FC630/FC640 compute sleds
PowerEdge FX2s	Up to four half-width PowerEdge FC630/FC640 compute sleds, or Up to eight PowerEdge FC430 compute sleds, or Up to two PowerEdge FC830 compute sleds, or Up to four PowerEdge FC430 compute sleds mixed with up to two PowerEdge FC630/FC640 compute sleds, or One PowerEdge FC830 compute sled mixed with up to two PowerEdge FC630/FC640 compute sleds

Storage sleds Specifications

PowerEdge FX2s	Up to three PowerEdge FD332 storage sleds mapped to one PowerEdge FC630/FC640 compute sled, or Up to two PowerEdge FD332 storage sleds mapped to two PowerEdge FC630/FC640 compute sleds, or Up to two PowerEdge FD332 storage sleds mapped to up to four PowerEdge FC430 compute sleds, or Up to two PowerEdge FD332 storage sleds mapped to one PowerEdge FC830 compute sled
-----------------------	---

NOTE: For more information on the technical specifications for the compute and storage sled(s), see the relevant sled Owner's Manual at Dell.com/poweredgemanuals.

NOTE: For information on mapping of storage sleds to compute sleds in the PowerEdge FX2s enclosure, see the *Dell PowerEdge FD332 Owner's Manual* at Dell.com/poweredgemanuals.

Power specifications

Power supply unit	Specifications
Wattage	1100 W (1050 W for low line) 1600 W (800 W for low line) 2000 W (1000 W for low line) 2400 W (1400 W for low line)
Connector	Card Edge
Heat dissipation	394 BTU/hr (full load for the power supply unit only) (1100 W power supply unit) 475 BTU/hr (full load for the power supply unit only) (1600 W power supply unit) 635 BTU/hr (full load for the power supply unit only) (2000 W power supply unit) 760 BTU/hr (full load for the power supply unit only) (2400 W power supply unit)
Maximum inrush current	25 A
System voltage requirements	100 – 240 V AC  NOTE: This system is also designed to be connected to IT power systems with a phase to phase voltage not exceeding 230 V.

Chassis Management Controller (CMC) specifications

Externally accessible connectors	Specifications
Remote management	Two dedicated 10/100/1000 Mb RJ-45 (for integrated Ethernet remote access controller). Gb port connects to the CMC module's external management network. STK port allows CMCs in adjacent enclosures to be daisy chained. The STK port can also be used for CMC NIC failover.
Serial	9-pin, DTE, 16550-compatible

Enclosure control panel specifications

Externally accessible connectors	Specifications
USB	One 4-pin, USB 1.1-compliant connector for keyboard and mouse support.
Video	15-pin VGA

I/O module specifications

 **NOTE:** For information on the technical specifications for the I/O modules, see the I/O module documentation at Dell.com/poweredgemanuals.

Environmental specifications

i **NOTE:** For additional information about environmental measurements for specific system configurations, see [Dell.com/environmental_datasheets](https://www.dell.com/environmental_datasheets).

Temperature Specifications

Maximum Temperature Gradient (Operating and Storage) 20 °C/h (36 °F/h)

Storage Temperature Limits -40 °C to 65 °C (-40 °F to 149 °F)

Relative humidity Specifications

Storage 5% to 95% RH with 33°C (91°F) maximum dew point. Atmosphere must be non-condensing at all times.

Temperature (Continuous Operation) Specifications

Temperature Ranges (for altitude less than 950 m or 3117 ft) 10 °C to 35 °C (50 °F to 95 °F) with no direct sunlight on the equipment.

Humidity Percentage Range 10% to 80% Relative Humidity with 26 °C (78.8 °F) maximum dew point.

Maximum vibration Specifications

Operating 0.26 G_{rms} at 5 Hz to 350 Hz (all operation orientations).

Storage 1.87 G_{rms} at 10 Hz to 500 Hz for 15 min (all six sides tested).

Maximum shock Specifications

Operating One shock pulse in the positive z axis of 31 G for 2.6 ms in all operational orientations.

Storage Six consecutively executed shock pulses in the positive and negative x, y, and z axes (one pulse on each side of the system) of 71 G for up to 2 ms.

Maximum altitude Specifications

Operating 3,048 m (10,000 ft)

Storage 12,000 m (39,370 ft).

Operating temperature de-rating Specifications

Up to 35 °C (95 °F) Maximum temperature is reduced by 1 °C/300 m (1 °F/547 ft) above 950 m (3,117 ft).

35 °C to 40 °C (95 °F to 104 °F) Maximum temperature is reduced by 1 °C/175 m (1 °F/319 ft) above 950 m (3,117 ft).

Operating temperature de-rating

40 °C to 45 °C
(104 °F to 113 °F)

Specifications

Maximum temperature is reduced by 1 °C/125 m (1 °F/228 ft) above 950 m (3,117 ft).

The following section defines the limits to help avoid IT equipment damage and/or failure from particulates and gaseous contamination. If the levels of particulates or gaseous pollution are beyond the specified limits and cause equipment damage or failure, you may need to rectify the environmental conditions. Remediation of environmental conditions is the responsibility of the customer.

Particulate contamination

Specifications

Air filtration

Data center air filtration as defined by ISO Class 8 per ISO 14644-1 with a 95% upper confidence limit.

NOTE: Applies to data center environments only. Air filtration requirements do not apply to IT equipment designed to be used outside a data center, in environments such as an office or factory floor.

NOTE: Air entering the data center must have MERV11 or MERV13 filtration.

Conductive dust

Air must be free of conductive dust, zinc whiskers, or other conductive particles.

NOTE: Applies to data center and non-data center environments.

Corrosive dust

- Air must be free of corrosive dust.
- Residual dust present in the air must have a deliquescent point less than 60% relative humidity.

NOTE: Applies to data center and non-data center environments.

Gaseous contamination

Specifications

Copper coupon corrosion rate

<300 Å/month per Class G1 as defined by ANSI/ISA71.04-1985.

Silver coupon corrosion rate

<200 Å/month as defined by AHSRAE TC9.9.

NOTE: Maximum corrosive contaminant levels measured at ≤50% relative humidity.

Expanded operating temperature

Expanded operating temperature

Specifications

< 10% of annual operating hours

5°C to 40°C at 5% to 85% RH with 26 °C dew point.

NOTE: Outside the standard operating temperature (10°C to 35°C), the system can operate down to 5°C or up to 40°C for a maximum of 10% of its annual operating hours.

For temperatures between 35°C and 40°C, de-rate maximum allowable dry bulb temperature by 1°C per 175 m above 950 m (1°F per 319 ft).

< 1% of annual operating hours

9–5°C to 45°C at 5% to 90% RH with 26°C dew point.

NOTE: Outside the standard operating temperature (10°C to 35°C), the system can operate down to –5°C or up to 45°C for a maximum of 1% of its annual operating hours.

For temperatures between 40°C and 45°C, de-rate maximum allowable dry bulb temperature by 1°C per 125 m above 950 m (1°F per 228 ft).

Expanded operating temperature

Expanded operating temperature restrictions

Specifications

- Do not perform a cold startup below 5°C.
- The operating temperature specified is for a maximum altitude of 3050 m (10,000 ft).
- Two redundant power supplies are required.
- Non Dell qualified peripheral cards and/or peripheral cards greater than 25 W are not supported.

i **NOTE:** For more information on the sled-specific restrictions for the expanded operating temperature range, see the technical specifications in the sled Owner's Manual at [Dell.com/poweredgemanuals](https://www.dell.com/poweredgemanuals).

Getting help

Topics:

- [Contacting Dell EMC](#)
- [Locating service tag of your system](#)
- [Accessing system information by using QRL](#)

Contacting Dell EMC

Dell EMC provides several online and telephone based support and service options. If you do not have an active internet connection, you can find contact information about your purchase invoice, packing slip, bill, or Dell EMC product catalog. Availability varies by country and product, and some services may not be available in your area. To contact Dell EMC for sales, technical assistance, or customer service issues:

Steps

1. Go to www.dell.com/support/home.
2. Select your country from the drop-down menu on the lower right corner of the page.
3. For customized support:
 - a. Enter your system Service Tag in the **Enter your Service Tag** field.
 - b. Click **Submit**.
The support page that lists the various support categories is displayed.
4. For general support:
 - a. Select your product category.
 - b. Select your product segment.
 - c. Select your product.
The support page that lists the various support categories is displayed.
5. For contact details of Dell EMC Global Technical Support:
 - a. Click [Global Technical Support](#).
 - b. The **Contact Technical Support** page is displayed with details to call, chat, or e-mail the Dell EMC Global Technical Support team.

Locating service tag of your system

Your system is identified by a unique Express Service Code and Service Tag number. The Express Service Code and Service Tag are found on the front of the system by pulling out the information tag. Alternatively, the information may be on a sticker on the chassis of the system. This information is used by Dell to route support calls to the appropriate personnel.

Accessing system information by using QRL

You can use the Quick Resource Locator (QRL) to get immediate access to the information about your system.

Prerequisites

Ensure that your smartphone or tablet has the QR code scanner installed.

About this task

The QRL includes the following information about your system:

- How-to videos
- Reference materials, including the Owner's Manual, LCD diagnostics, and mechanical overview

- Your system service tag to quickly access your specific hardware configuration and warranty information
- A direct link to Dell to contact technical support and sales teams

Steps

1. Go to **Dell.com/QRL** and navigate to your specific product or
2. Use your smartphone or tablet to scan the model-specific Quick Resource (QR) code located in the following image or on your Dell PowerEdge system:

