

Dell PowerEdge C6525

Installation and Service Manual

Notes, cautions, and warnings

 **NOTE:** A NOTE indicates important information that helps you make better use of your product.

 **CAUTION:** A CAUTION indicates either potential damage to hardware or loss of data and tells you how to avoid the problem.

 **WARNING:** A WARNING indicates a potential for property damage, personal injury, or death.

Chapter 1: About this document	6
Chapter 2: Dell EMC PowerEdge C6525 overview	7
Inside view of the sled.....	7
Rear view of the sled.....	8
Network ports indicator codes.....	8
Locating the Express Service Code and Service Tag.....	9
System information label.....	10
Chapter 3: Initial system setup and configuration	13
Setting up the system.....	13
iDRAC configuration.....	13
Options to set up iDRAC IP address.....	13
Options to log in to iDRAC.....	15
Resources to install operating system.....	15
Options to download firmware	16
Options to download and install OS drivers	16
Downloading drivers and firmware.....	16
Chapter 4: Installing and removing system components	18
Safety instructions.....	18
Before working inside your system.....	18
After working inside your system.....	19
Recommended tools.....	19
Sled.....	19
Removing a sled	19
Installing a sled	20
Sled installation guidelines.....	22
Air shroud.....	23
Removing the air shroud.....	23
Installing the air shroud	23
System memory.....	24
General memory module installation guidelines.....	24
System memory guidelines.....	28
Removing a memory module.....	29
Installing a memory module.....	30
Support bracket.....	31
Removing the support bracket.....	31
Installing the support bracket.....	32
Expansion cards.....	33
Expansion card installation guidelines.....	33
Removing the expansion card riser 1.....	36
Installing the expansion card riser 1.....	37
Removing the expansion card riser 2.....	38

Installing the expansion card riser 2.....	39
Removing an expansion card.....	40
Installing an expansion card.....	43
Removing the riser card.....	46
Installing the riser card.....	48
M.2 riser	49
Removing the M.2 riser.....	49
Installing the M.2 riser.....	50
M.2 SSD module.....	51
Removing the M.2 SSD module.....	51
Installing the M.2 SSD module.....	51
Linking board and PCIe cable.....	52
Removing the linking board and PCIe cable.....	52
Installing the linking board and PCIe cable.....	53
Processor and heat sink.....	54
Removing the heat sink.....	54
Removing the processor.....	55
Installing the processor.....	57
Installing the heat sink.....	59
Liquid cooling heat sink with liquid leak sensor.....	61
Removing the liquid cooling heat sink with liquid leak sensor cover.....	61
Removing the liquid cooling heat sink with liquid leak sensor.....	62
Installing the liquid cooling heat sink with liquid leak sensor.....	63
Installing the liquid cooling heat sink cover.....	64
OCP cards.....	65
Removing the OCP filler.....	65
Installing an OCP card.....	66
Removing an OCP card.....	67
Installing the OCP card filler.....	68
System battery.....	69
Replacing system battery.....	69
System board.....	71
Removing the system board.....	71
Installing the system board	72
Trusted Platform Module.....	74
Upgrading the Trusted Platform Module.....	74
Initializing TPM for users.....	75
Initializing the TPM 1.2 for users.....	75
Initializing the TPM 2.0 for users.....	75
Chapter 5: Jumpers and connectors.....	76
System board connectors.....	76
System board jumper settings.....	77
Disabling a forgotten password.....	78
Chapter 6: System diagnostics.....	79
Dell Embedded System Diagnostics.....	79
Running the Embedded System Diagnostics from Boot Manager.....	79
Running the Embedded System Diagnostics from the Dell Lifecycle Controller.....	79

System diagnostic controls.....	79
Chapter 7: Known Issue.....	81
Chapter 8: Getting help.....	82
Recycling or End-of-Life service information.....	82
Contacting Dell.....	82
Accessing system information by using QRL.....	82
Quick Resource Locator for PowerEdge C6525 system.....	83
Receiving automated support with SupportAssist	83
Chapter 9: Documentation resources.....	84

About this document

This document provides an overview about the system, information about installing and replacing components, diagnostic tools, and guidelines to be followed while installing certain components.

Dell EMC PowerEdge C6525 overview

The PowerEdge C6525 is a half-width sled that supports:

- Two AMD EPYC 7002 and 7003 Series processors
- 16 DIMM slots

The sled also supports PCIe and Open Compute Project (OCP) risers for expansion and connectivity.

For more information, see the Dell Technologies PowerEdge C6525 Technical Specifications on the product documentation page.

⚠ WARNING: Consumer-Grade GPU should not be installed or used in the Enterprise Server products.

Topics:

- [Inside view of the sled](#)
- [Rear view of the sled](#)
- [Network ports indicator codes](#)
- [Locating the Express Service Code and Service Tag](#)
- [System information label](#)

Inside view of the sled

The inside view of the PowerEdge C6525 sled:

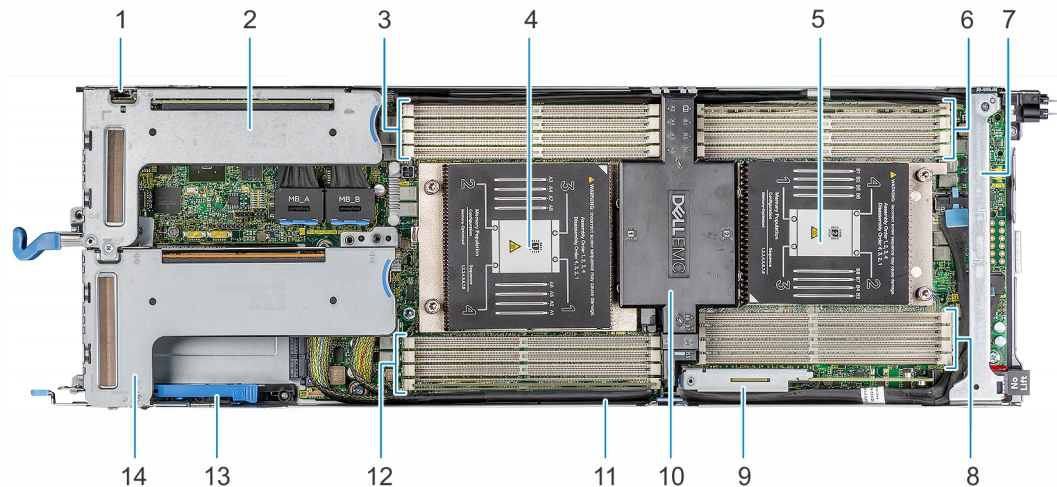

Figure 1. Inside view of the PowerEdge C6525 sled

- | | |
|---|-------------------------------------|
| 1. uSD card slot | 2. Expansion card riser 1 |
| 3. Memory module sockets for CPU 1 | 4. Processor socket 1 |
| 5. Processor socket 2 | 6. Memory module sockets for CPU 2 |
| 7. Support bracket | 8. Memory module sockets for CPU 2 |
| 9. M.2 riser | 10. Air shroud |
| i NOTE: Supports M.2 SATA card / BOSS card S1V5 | |
| 11. Riser 2 cable | 12. Memory module sockets for CPU 1 |
| 13. OCP card retention latch | 14. Expansion card riser 2 |

For more information, see the Dell Technologies PowerEdge C6525 Technical Specifications on the product documentation page.

Rear view of the sled

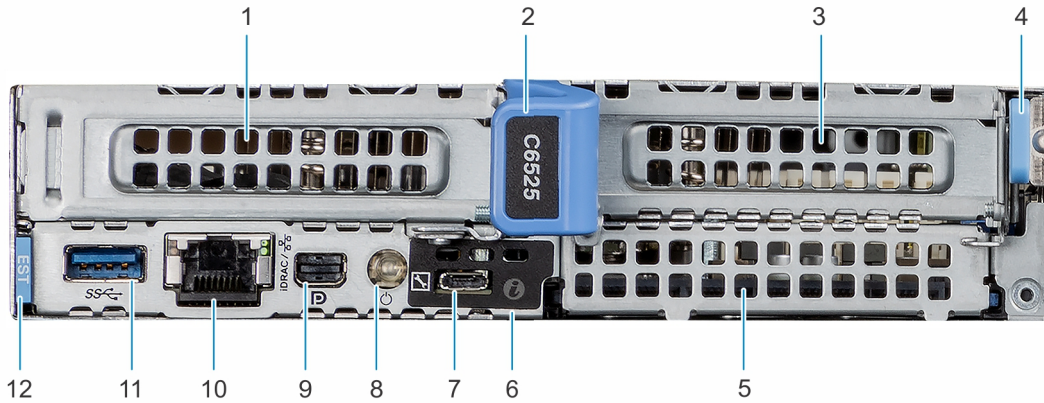

Figure 2. Rear view of the sled

- | | |
|--------------------------------|------------------------------|
| 1. PCIe expansion card riser 1 | 2. Sled release handle |
| 3. PCIe expansion card riser 2 | 4. Sled release lock |
| 5. OCP 3.0 SFF card slot | 6. System identification LED |
| 7. iDRAC Direct micro USB port | 8. Sled power button |
| 9. Mini display port | 10. iDRAC or NIC port |
| 11. USB 3.0 port | 12. Information tag |

For more information, see the Dell Technologies PowerEdge C6525 Technical Specifications on the product documentation page.

Network ports indicator codes

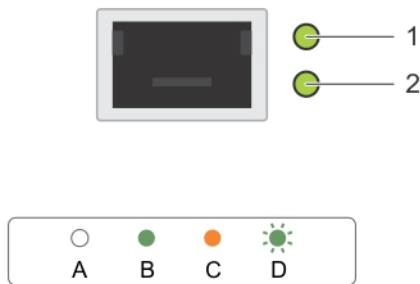

Figure 3. LAN indicators on the QSFP OCP card

1. Link indicator
2. Activity indicator

Table 1. QSFP port on OCP card indicator codes

Connection State	QSFP Upper green LED	QSFP Lower green LED
No link/Not Connected	Off	Off
InfiniBand Physical Link - No Logical Link	Green	Off

Table 1. QSFP port on OCP card indicator codes (continued)

Connection State	QSFP Upper green LED	QSFP Lower green LED
InfiniBand Logical Link - No Traffic	Green	Green
InfiniBand Logical Link - Traffic	Green	Blink
InfiniBand Physical Link Issue	Blink	Green
Ethernet Link - No Traffic	Green	Green
Ethernet - Traffic	Green	Blink

NOTE: The LED blink speed varies according to the traffic bandwidth.

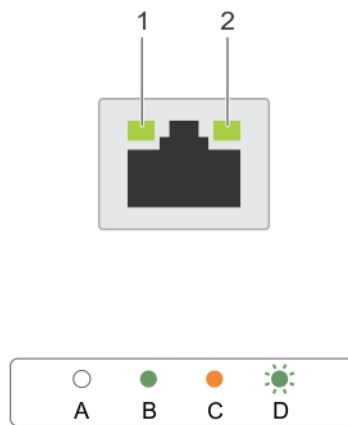

Figure 4. Ethernet port indicator codes

1. Speed indicator
2. Link and activity indicator

Table 2. Ethernet port indicator codes

Convention	Status	Condition
A	Link and activity indicators are off	The NIC is not connected to the network.
B	Link indicator is green	The NIC is connected to a valid network at its maximum port speed.
C	Link indicator is amber	The NIC is connected to a valid network at less than its maximum port speed.
D	Activity indicator is flashing green	Network data is being sent or received.

Locating the Express Service Code and Service Tag

The unique Express Service Code and Service Tag are used to identify the system.

The information tag is located on the rear of the system that includes system information such as Service Tag, Express Service Code, Manufacture date, NIC, MAC address, QRL label, and so on. If you have opted for the secure default access to iDRAC, the Information tag also contains the iDRAC secure default password. If you have opted for iDRAC Quick Sync 2, the Information tag also contains the OpenManage Mobile (OMM) label, where administrators can configure, monitor, and troubleshoot the PowerEdge servers.

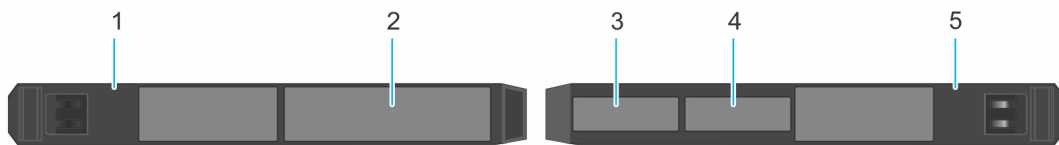

Figure 5. Locating the Service Tag of your system

1. Information tag (top view)
2. Express Service Tag label
3. Network MAC address information label
4. iDRAC MAC address information label
5. Information tag (bottom view)

The Mini Enterprise Service Tag (MEST) label is located on the rear of the system that includes Service Tag (ST), Express Service Code (Exp Svc Code), and Manufacture Date (Mfg. Date). The Exp Svc Code is used by Dell EMC to route support calls to the appropriate personnel.

Alternatively, the Service Tag information is located on a label on left wall of the chassis.

System information label

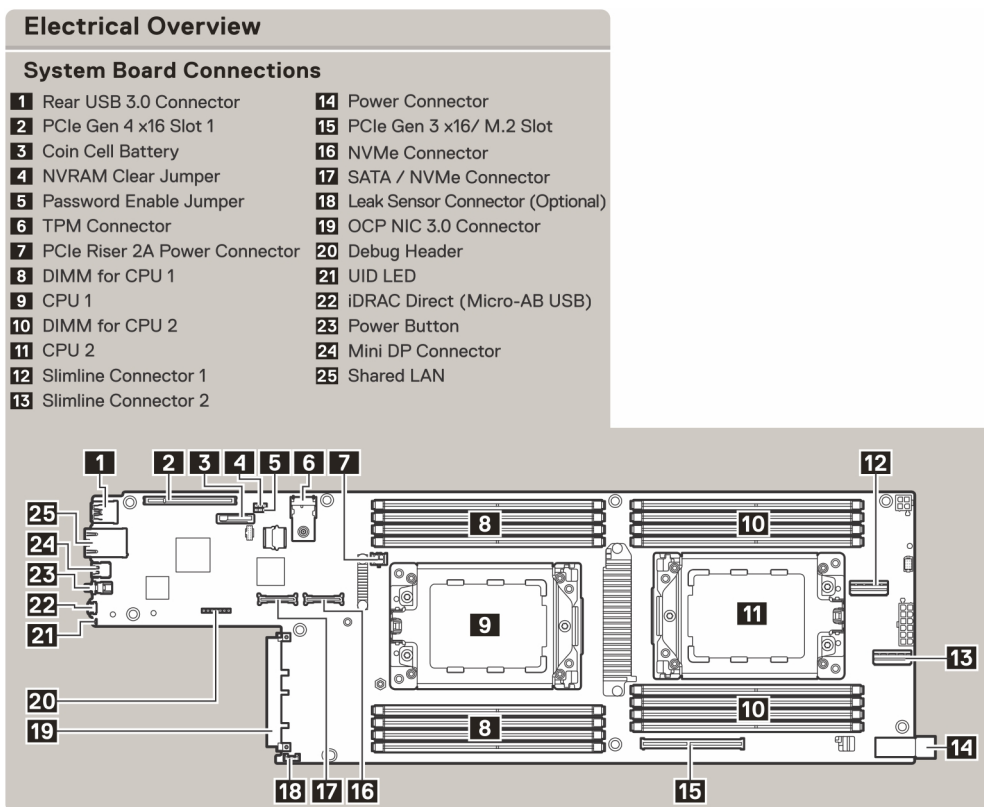

Figure 6. System board connections

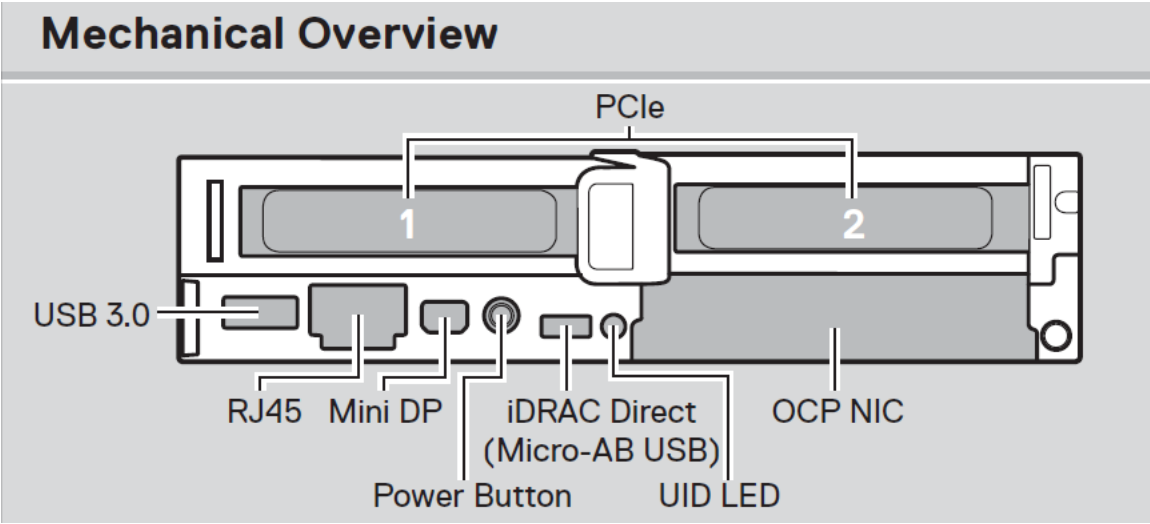



Figure 7. Mechanical overview

Memory Information

⚠ Caution: Memory (DIMMs) and CPUs may be hot during servicing.

A3 →
 A4 →
 A7 →
 A8 →



A6 →
 A5 →
 A2 →
 A1 →

← B1
 ← B2
 ← B5
 ← B6



← B8
 ← B7
 ← B4
 ← B3

Memory Population Configuration	Sequence
Memory-Optimized	1,2,3,4,5,6,7,8

Latest population rules are documented in the *Installation and Service Manual*.

Figure 8. Memory information

Jumper Settings







Jumper	Setting	Description
NVRAM_CLR 	 (default)	BIOS configuration settings retained at system boot.
		BIOS configuration setting cleared at system boot.
PWRD_EN 	 (default)	BIOS password is enabled.
		BIOS password is disabled. iDRAC local access unlocked at next AC power cycle. iDRAC password reset is enabled in F2 iDRAC settings menu.

Figure 9. Jumper settings

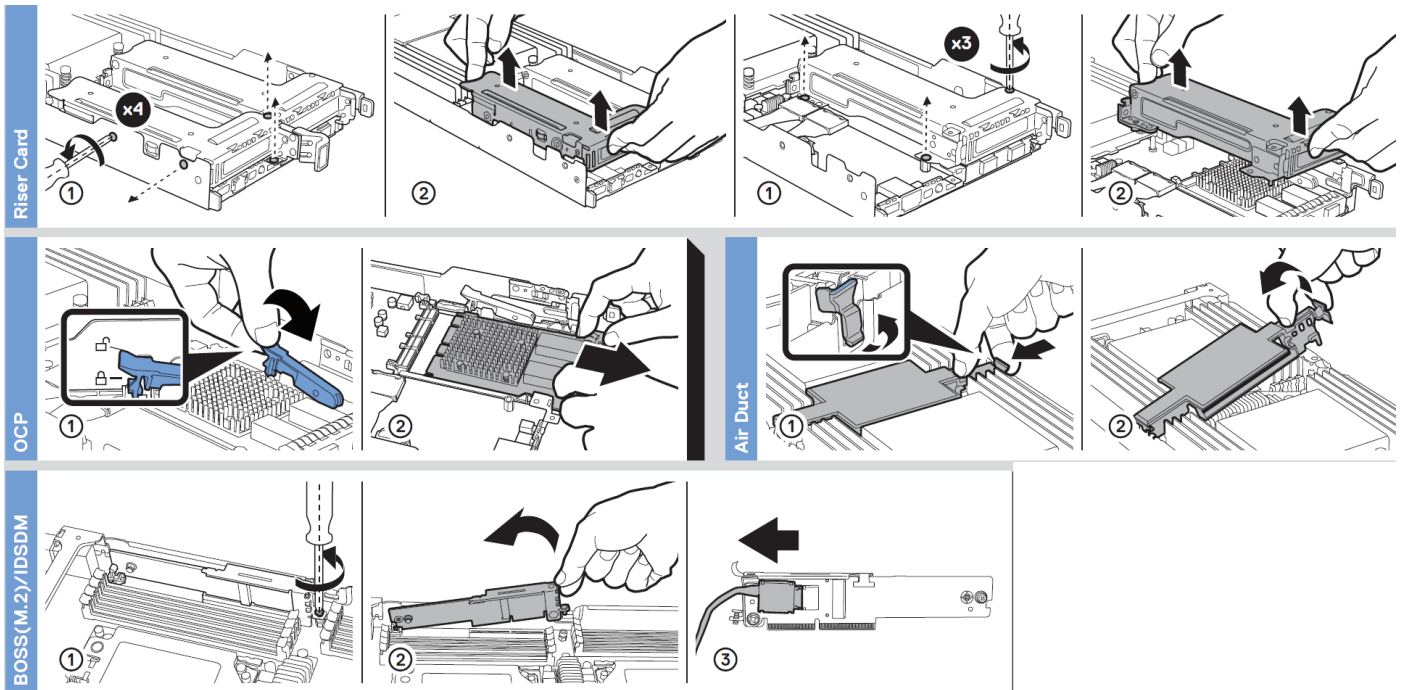

Figure 10. System tasks

Initial system setup and configuration

This section describes the tasks for initial setup and configuration of the Dell system. The section also provides general steps to set up the system and the reference guides for detailed information.

Topics:

- [Setting up the system](#)
- [iDRAC configuration](#)
- [Resources to install operating system](#)

Setting up the system

Perform the following steps to set up the system:

Steps

1. Unpack the system.
2. Install the system into the rack. For more information, see the rail installation and cable management accessory guides relevant to your rail and cable management solution at [PowerEdge manuals](#).
3. Connect the peripherals to the system and the system to the electrical outlet.
4. Power on the system by pressing the power button.

For more information about setting up the system, see the *Getting Started Guide* that is shipped with your system.

For information on how to manage basic settings and features of the system, see the Dell Technologies PowerEdge C6525 BIOS and UEFI Reference Guide on the product documentation page.

iDRAC configuration

The Integrated Dell Remote Access Controller (iDRAC) is designed to make you more productive as a system administrator and improve the overall availability of Dell EMC servers. iDRAC alerts you to system issues, helps you to perform remote management, and reduces the need for physical access to the system.

Options to set up iDRAC IP address

To enable communication between your system and iDRAC, you must first configure the network settings based on your network infrastructure. The network settings option is set to **DHCP**, by default.

 **NOTE:** For static IP configuration, you must request for the setting at the time of purchase.

You can set up the iDRAC IP address using one of the following interfaces. For information about how to set up iDRAC IP address, see the documentation links provided in the table.

Table 3. Interfaces to set up iDRAC IP address

Interface	Documentation links
iDRAC Settings utility	<i>Integrated Dell Remote Access Controller User's Guide</i> at iDRAC Manuals or for system specific <i>Integrated Dell Remote Access Controller User's Guide</i> , go to PowerEdge

Table 3. Interfaces to set up iDRAC IP address (continued)

Interface	Documentation links
	<p>Manuals > Product Support page of your system > Manuals & documents.</p> <p>i NOTE: To determine the most recent iDRAC release for your platform and for latest documentation version, see KB article Integrated Dell Remote Access Controller 9 Versions and Release Notes.</p>
OpenManage Deployment Toolkit	<p><i>Dell OpenManage Deployment Toolkit User's Guide</i> available on the OpenManage manuals page. > Open Manage Deployment Toolkit.</p>
iDRAC Direct	<p><i>Integrated Dell Remote Access Controller User's Guide</i> at iDRAC Manuals or for system specific <i>Integrated Dell Remote Access Controller User's Guide</i>, go to PowerEdge Manuals > Product Support page of your system > Manuals & documents.</p> <p>i NOTE: To determine the most recent iDRAC release for your platform and for latest documentation version, see KB article Integrated Dell Remote Access Controller 9 Versions and Release Notes.</p>
Lifecycle Controller	<p><i>Lifecycle Controller User's Guide</i> at iDRAC Manuals or for system specific <i>Lifecycle Controller User's Guide</i>, go to PowerEdge Manuals > Product Support page of your system > Manuals & documents.</p> <p>i NOTE: To determine the most recent iDRAC release for your platform and for latest documentation version, see KB article Integrated Dell Remote Access</p>

Table 3. Interfaces to set up iDRAC IP address (continued)

Interface	Documentation links
	Controller 9 Versions and Release Notes.

NOTE: To access iDRAC, ensure that you connect the ethernet cable to the iDRAC9 dedicated network port or use iDRAC Direct port by using the USB cable. You can also access iDRAC through the shared LOM mode, if you have opted for a system that has the shared LOM mode enabled.

Options to log in to iDRAC

To log in to the iDRAC Web User Interface, open a browser and enter the IP address.

You can log in to iDRAC as:

- iDRAC user
- Microsoft Active Directory user
- Lightweight Directory Access Protocol (LDAP) user

In the log in screen displayed, if you have opted for secure default access to iDRAC, enter the iDRAC secure default password available on back side of the Information Tag. If you have not opted for secure default access to iDRAC, enter the default user name and password – `root` and `calvin`. You can also log in by using your Single Sign-On or Smart Card.

NOTE: Ensure that you change the default username and password after setting up the iDRAC IP address.

For more information about logging in to the iDRAC and iDRAC licenses, see the latest *Integrated Dell Remote Access Controller User's Guide* at [idrac manuals](#).

NOTE: To determine the most recent iDRAC release for your platform and for latest documentation version, see KB article [KB78115](#).

You can also access iDRAC using command-line protocol - RACADM. For more information, see the *iDRAC with Lifecycle Controller RACADM CLI Guide* available at [idrac manuals](#).

You can also access iDRAC using automation tool - Redfish API. For more information, see the *iDRAC9 with Lifecycle Controller Redfish API Guide* available at [iDRAC Manuals](#).

Resources to install operating system

If the system is shipped without an operating system, you can install a supported operating system by using one of the resources provided in the table. For information about how to install the operating system, see the documentation links provided in the table.

Table 4. Resources to install the operating system

Resource	Documentation links
iDRAC	<p><i>Integrated Dell Remote Access Controller User's Guide</i> at iDRAC Manuals or for system specific <i>Integrated Dell Remote Access Controller User's Guide</i>, go to PowerEdge Manuals > Product Support page of your system > Manuals & documents.</p> <p>NOTE: To determine the most recent iDRAC release for your platform and for latest documentation version, see KB article at Integrated Dell Remote Access Controller 9 Versions and Release Notes.</p>
Lifecycle Controller	<p><i>Lifecycle Controller User's Guide</i> at iDRAC Manuals or for system specific <i>Lifecycle Controller User's Guide</i>, go to PowerEdge Manuals > Product Support page of your system > Manuals & documents. Dell recommends using Lifecycle Controller to install the OS, since all required drivers are installed to the system.</p> <p>NOTE: To determine the most recent iDRAC release for your platform and for latest documentation version, see KB article at Integrated Dell Remote Access Controller 9 Versions and Release Notes.</p>

Table 4. Resources to install the operating system (continued)

Resource	Documentation links
OpenManage Deployment Toolkit	OpenManage Manuals > OpenManage Deployment Toolkit
Dell certified VMware ESXi	Virtualization solutions

i **NOTE:** For more information about Installation and How-to videos for supported operating systems on PowerEdge system see, [Supported Operating Systems for Dell EMC PowerEdge systems](#).

Options to download firmware

You can download firmware from the Dell support site. For information, see the [Downloading drivers and firmware](#) section.

You can also choose any one of the following options to download the firmware. For information about how to download the firmware, see the documentation links provided in the table.

Table 5. Options to download firmware

Option	Documentation link
Using Dell Remote Access Controller Lifecycle Controller (iDRAC with LC)	idrac manuals
Using Dell Repository Manager (DRM)	OpenManage Manuals > Repository Manager
Using Dell Server Update Utility (SUU)	OpenManage Manuals > Server Update Utility
Using Dell OpenManage Deployment Toolkit (DTK)	OpenManage Manuals > OpenManage Deployment Toolkit
Using iDRAC virtual media	idrac manuals

Options to download and install OS drivers

You can choose any one of the following options to download and install OS drivers. For information about how to download or install OS drivers, see the documentation links provided in the table.

Table 6. Options to download and install OS drivers

Option	Documentation
Dell EMC support site	Downloading drivers and firmware section.
iDRAC virtual media	<p><i>Integrated Dell Remote Access Controller User's Guide</i> at iDRAC Manuals or for system specific <i>Integrated Dell Remote Access Controller User's Guide</i>, go to PowerEdge Manuals > Product Support page of your system > Manuals & documents.</p> <p>i NOTE: To determine the most recent iDRAC release for your platform and for latest documentation version, see Integrated Dell Remote Access Controller 9 Versions and Release Notes.</p>

Downloading drivers and firmware

It is recommended that you download and install the latest BIOS, drivers, and systems management firmware on the system.

Prerequisites

Ensure that you clear the web browser cache before downloading the drivers and firmware.

Steps

1. Go to [Drivers](#).
2. Enter the Service Tag of the system in the **Enter a Dell Service Tag, Dell EMC Product ID or Model** field, and then press Enter.
 **NOTE:** If you do not have the Service Tag, select **Detect PC** to automatically detect the Service Tag, or click **Browse all products**, and navigate to your product.
3. On the displayed product page, click **Drivers & Downloads**.
On the **Drivers & Downloads** page, all drivers that are applicable to the system are displayed.
4. Download the drivers to a USB drive, CD, DVD or local machine.

Installing and removing system components

Topics:

- Safety instructions
- Before working inside your system
- After working inside your system
- Recommended tools
- Sled
- Air shroud
- System memory
- Support bracket
- Expansion cards
- M.2 riser
- M.2 SSD module
- Linking board and PCIe cable
- Processor and heat sink
- Liquid cooling heat sink with liquid leak sensor
- OCP cards
- System battery
- System board
- Trusted Platform Module

Safety instructions

 **NOTE:** Whenever you need to lift the system, get others to assist you. To avoid injury, do not attempt to lift the system by yourself.

 **WARNING:** Opening or removing the system cover while the system is powered on may expose you to a risk of electric shock.

 **CAUTION:** Do not operate the system without the cover for a duration exceeding five minutes. Operating the system without the system cover can result in component damage.

 **CAUTION:** Many repairs may only be done by a certified service technician. You should only perform troubleshooting and simple repairs as authorized in your product documentation, or as directed by the online or telephone service and support team. Damage due to servicing that is not authorized by Dell is not covered by your warranty. Read and follow the safety instructions that are shipped with your product.

 **NOTE:** It is recommended that you always use an antistatic mat and antistatic strap while working on components inside the system.

 **CAUTION:** To ensure proper operation and cooling, all bays in the system and system fans must be always populated with a component or a blank.

Before working inside your system

Prerequisites

Follow the safety guidelines listed in [Safety instructions](#).

Steps

1. Power off the system, including all attached peripherals.
2. Disconnect the system from the electrical outlet and disconnect the peripherals.
3. Remove the sled from the enclosure.

After working inside your system

Prerequisites

Follow the safety guidelines listed in [Safety instructions](#).

Steps

1. Reconnect the peripherals and connect the system to the electrical outlet.
2. Power on the attached peripherals and then power on the system.

Recommended tools

You need the following tools to perform the removal and installation procedures:

- Key to the bezel lock. The key is required only if your system includes a bezel.
- Phillips #1 screwdriver
- Phillips #2 screwdriver
- Torx #T20 screwdriver
- 5mm hex nut screwdriver
- Plastic scribe
- 1/4 inch flat blade screwdriver
- Wrist grounding strap connected to the ground
- ESD mat

Sled

Removing a sled

Prerequisites

1. Follow the safety guidelines listed in [Safety Instructions](#).

 **NOTE:** For optimized thermal performance, see [Sled installation guidelines](#).

 **NOTE:** The procedure to remove a sled blank or a sled is similar.

Steps

Press the retention latch and holding the sled handle, pull the sled out of the enclosure.

 **CAUTION:** Ensure that the sled is supported with both hands while it is being slid out.

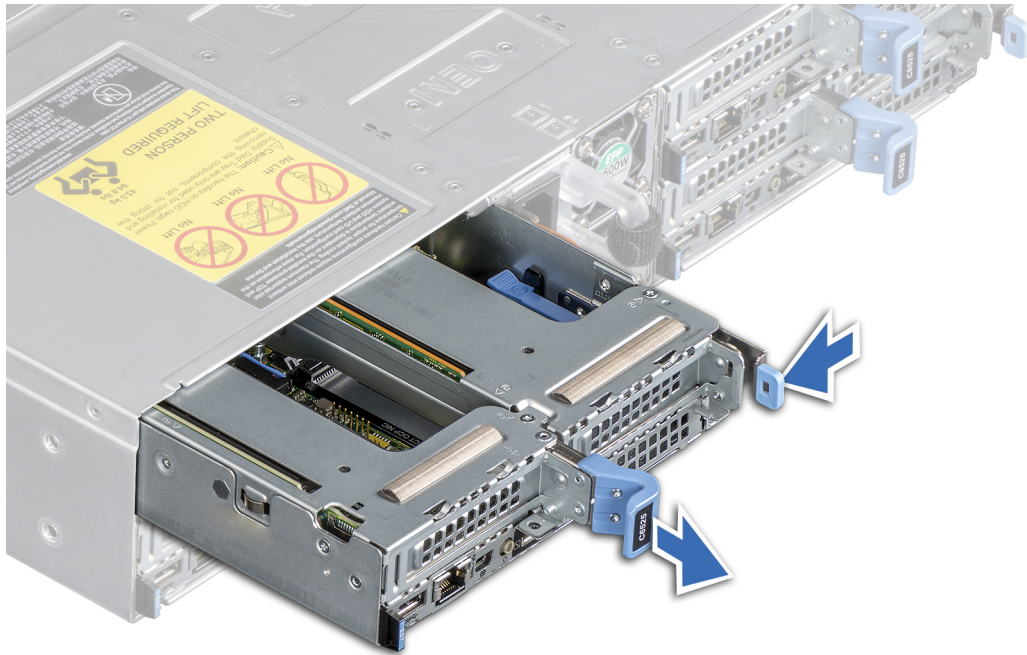

Figure 11. Removing a sled

Next steps

1. [Replace the sled.](#)

Installing a sled

Prerequisites

1. Follow the safety guidelines listed in [Safety Instructions](#).

i **NOTE:** To avoid injury, ensure that the sled is supported from beneath.

Steps

1. Align the sled to the enclosure horizontally to insert the sled into the enclosure.

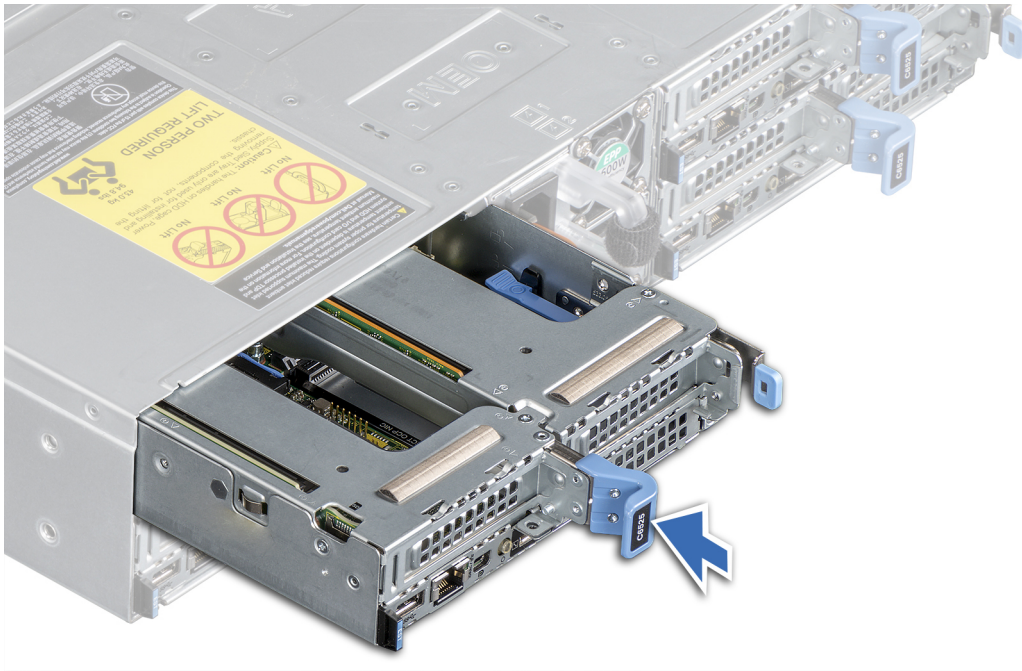

Figure 12. Installing a sled

2. Push the blue retention latch to slide the sled into the enclosure, and stop the sled at a distance of 20-30 mm before complete insertion of the sled as shown in the image below.

CAUTION: To avoid any damages to the pins on the sled, do not force the sled into the enclosure. Follow the two-position insertion and gently slide the sled into the enclosure.

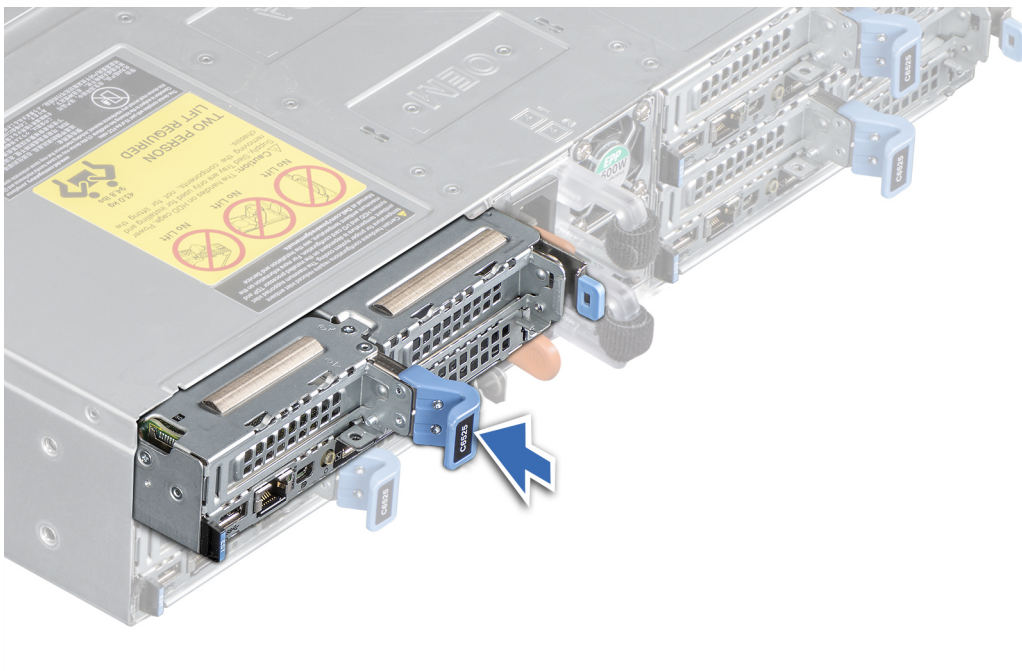

Figure 13. Stop the sled at a distance of 20-30 mm before complete insertion

3. Slide the blue retention latch gently, until the sled locks into the place.

Sled installation guidelines

CAUTION: Mixing of sled models in a system is not supported. Do not install predecessor sled models with the PowerEdge C6525 sled.

CAUTION: Ensure that the chassis does not have a mixed architecture of PowerEdge C6420 and PowerEdge C6525 sled configurations.

NOTE: Ensure to install a sled blank in all the empty slots. Operating the enclosure without a blank results in overheating.

NOTE: For optimized thermal operation, ensure to follow the sled population sequence mentioned below:

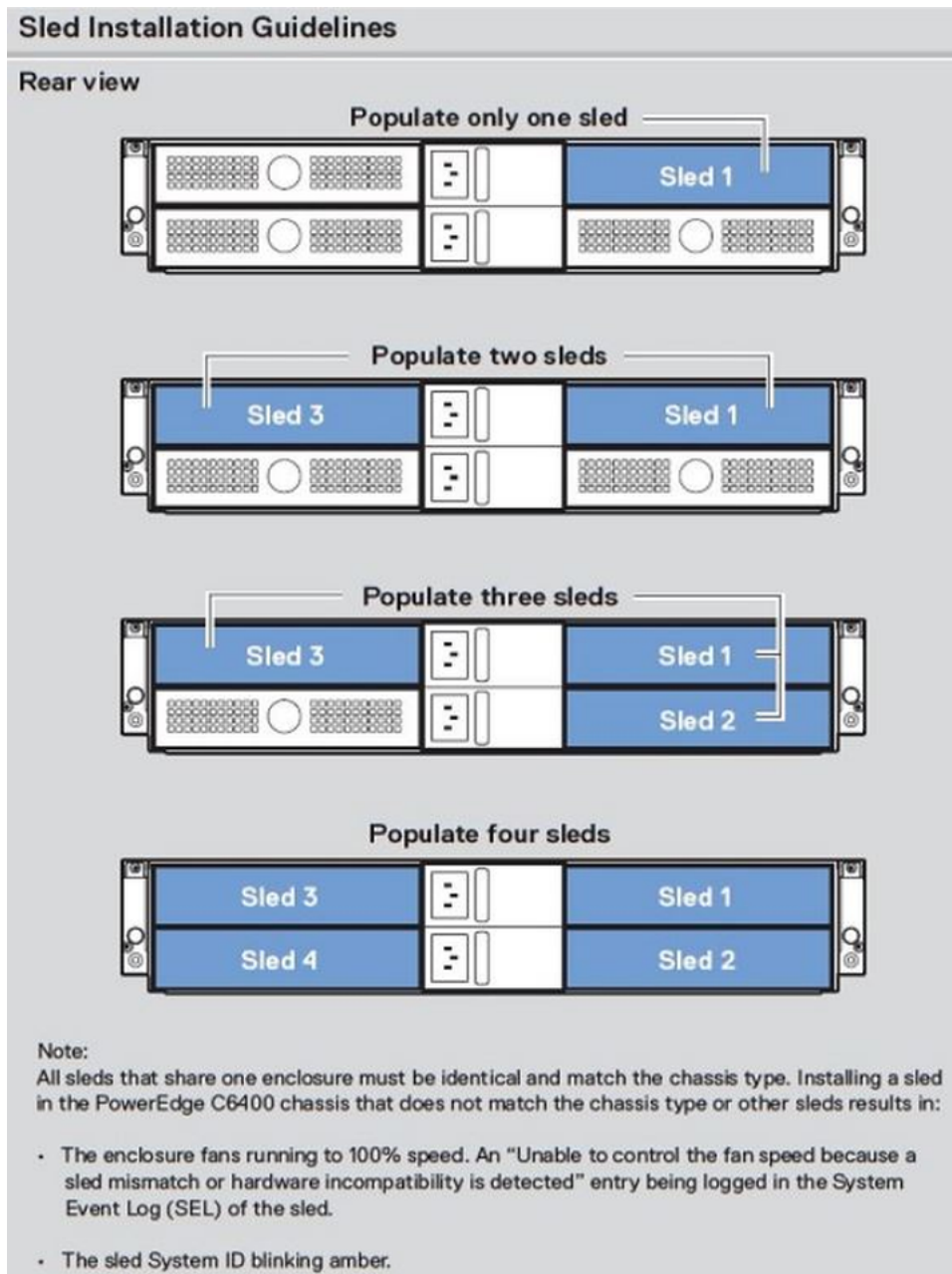

Figure 14. Sled Installation Guidelines

Air shroud

Removing the air shroud

Prerequisites

1. Follow the safety guidelines listed in [Safety instructions](#).
2. Follow the procedure listed in [Before working inside your system](#).
3. If applicable, disconnect the PERC battery cable from the connector on the system board.

Steps

1. Press the blue clip and lift the air shroud.
2. Disengage the air shroud hook from the slot on the chassis and remove the air shroud.

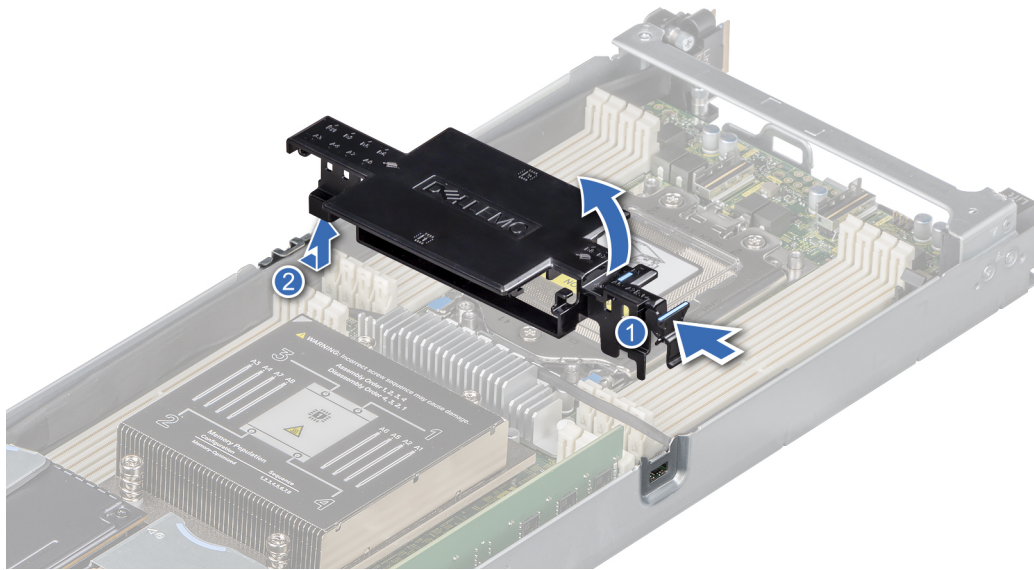

Figure 15. Removing the air shroud

Next steps

1. [Install the air shroud](#).

Installing the air shroud

Prerequisites

1. Follow the safety guidelines listed in [Safety instructions](#).
2. If applicable, connect the PERC battery cable to the connector on the system board.

Steps

1. Insert the hook on the air shroud into the slot on the chassis.

NOTE: Ensure that the SATA cables are routed behind the air shroud clip.

NOTE: Route the cable properly to prevent the cable from being pinched or crimped.

2. Lower the air shroud until the blue clip locks in place.

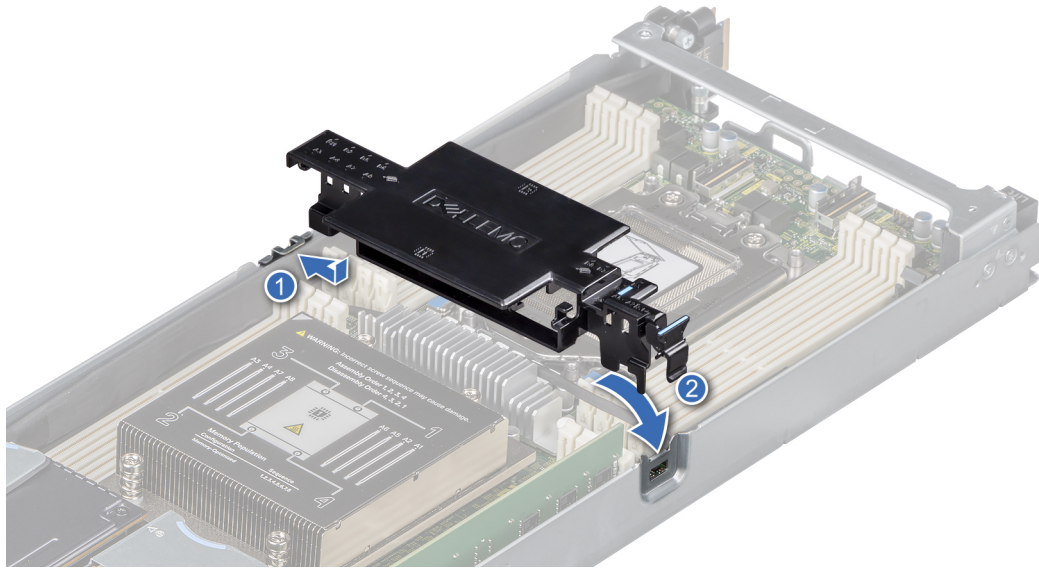

Figure 16. Installing the air shroud

Next steps

1. Follow the procedure listed in [After working inside your system.](#)

System memory

General memory module installation guidelines

To ensure optimal performance of your system, observe the following general guidelines when configuring your system memory. If your system's memory configurations fail to observe these guidelines, your system might not boot, stop responding during memory configuration, or operate with reduced memory. This section provides information on the memory population rules and about the non-uniform memory access (NUMA) for single or dual processor system.

The memory bus may operate at speeds of 4800 MT/s, 3200 MT/s, 2933 MT/s, or 2666 MT/s depending on the following factors:

- System profile selected (for example, Performance Optimized, or Custom [can be run at high speed or lower])
- Maximum supported DIMM speed of the processors
- Maximum supported speed of the DIMMs

NOTE: MT/s indicates DIMM speed in MegaTransfers per second.

The system supports Flexible Memory Configuration, enabling the system to be configured and run in any valid chipset architectural configuration. The following are the recommended guidelines for installing memory modules:

- All DIMMs must be DDR4 and above.
- Mixing of memory module capacities in a system is not supported.
- If memory modules with different speeds are installed, they operate at the speed of the slowest installed memory module(s).
- Populate memory module sockets only if a processor is installed.
 - In Optimizer Mode, the DRAM controllers operate independently in the 64-bit mode and provide optimized memory performance.

Table 7. Memory population rules

Processor	Configuration	Memory population	Memory population information
Single processor	Optimizer (Independent channel) population order	A{1}, A{2}, A{3}, A{4}, A{5}, A{6}, A{7}, A{8}	Odd amount of DIMMs per processor allowed.

Table 7. Memory population rules (continued)

Processor	Configuration	Memory population	Memory population information
Dual processor (Start with processor 1. Processor 1 and processor 2 population should match)	Optimizer (Independent channel) population order	A{1}, B{1}, A{2}, B{2}, A{3}, B{3}, A{4}, B{4}, A{5}, B{5}, A{6}, B{6}, A{7}, B{7}, A{8}, B{8}	<p>Odd amount of DIMMs per processor allowed.</p> <p>i NOTE: Odd number of DIMMs will result in unbalanced memory configurations, which in turn will result in performance loss. It is recommended to populate all memory channels identically with identical electrical specification DIMMs for best performance.</p> <p>Optimizer population order is not traditional for 8 and 16 DIMMs installations for dual processor.</p> <ul style="list-style-type: none"> ▪ For 8 DIMMs: A{6}, A{5}, A{2}, A{1}, A{8}, A{7}, A{4}, A{3} ▪ For 16 DIMMs: A{6}, B{6}, A{5}, B{5}, A{2}, B{2}, A{1}, B{1}, A{8}, B{8}, A{7}, B{7}, A{4}, B{4}, A{3}, B{3}

- Populate all the sockets with white release tabs first, followed by the black release tabs.
 - In a dual-processor configuration, the memory configuration for each processor must be identical. For example, if you populate socket A1 for processor 1, then populate socket B1 for processor 2, and so on.
 - Unbalanced or odd memory configuration results in a performance loss and system may not identify the memory modules being installed, so always populate memory channels identically with equal DIMMs for best performance.
 - Minimum recommended configuration is to populate four equal memory modules per processor. AMD recommends limiting processors in that system to 32 cores or less.
 - Populate eight equal memory modules per processor (one DIMM per channel) at a time to maximize performance.
- i** **NOTE:** Equal memory modules refer to DIMMs with identical electrical specification and capacity that may be from different vendors.

Memory interleaving with Non-uniform memory access (NUMA)

Non-uniform memory access (NUMA) is a memory design used in multi-processing, where the memory access time depends on the memory location relative to the processor. In NUMA, a processor can access its own local memory faster than the non-local memory.

NUMA nodes per socket (NPS) is a new feature added that allows you to configure the memory NUMA domains per socket. The configuration can consist of one whole domain (NPS1), two domains (NPS2), or four domains (NPS4). In the case of a two-socket platform, an additional NPS profile is available to have whole system memory to be mapped as single NUMA domain (NPS0). For more information on the memory interleaving for NPSx, see the Memory interleaving population rules section in this topic.

BIOS implementation for NPSx

- The BIOS Setup menu presents the applicable NPSx options based on the underlying model number. A change to the current NPSx is communicated to pre-BIOS firmware to take effect on the next boot. The default NPS setting is 1.
- During boot, if the selected NPSx option is not allowed for the model number (for example, if the processor model number changes between reboot), system will halt at the end of POST with UEFI0388 message displayed. On the next reboot, the system will fall back to NPS1 default setting.
- During boot, if the preferred interleaving for the current NPSx is not possible due to memory configuration (for example, the memory population is inconsistent with the preferred interleaving), BIOS shows a warning message UEFI0391.

i **NOTE:** System is functional when UEFI0391 message is displayed. However, the system may not be configured for optimal performance.

NPS system optimization

Optimal system configuration is dependent on the processor model, memory configuration, and NPS settings. Match the memory configuration with the NPS settings available for the processor.

Table 8. Supported NPS modes by Processors

Model Number	NPS modes supported
7773X	4, 2, 1, 0
7573X	4, 2, 1, 0
7473X	4, 2, 1, 0
7373X	4, 2, 1, 0
75F3	4, 2, 1, 0
7713P	4, 2, 1
7663	4, 2, 1, 0
7513	4, 2, 1, 0
7543P	4, 2, 1
7453	4, 2, 1, 0
74F3	4, 2, 1, 0
7443	4, 2, 1, 0
7443P	4, 2, 1
73F3	4, 2, 1, 0
7343	4, 2, 1, 0
7313P	4, 2, 1
7643	4, 2, 1, 0
72F3	4, 2, 1, 0
7742	4, 2, 1, 0
7702	4, 2, 1, 0
7702P	4, 2, 1
7662	4, 2, 1, 0
7642	4, 2, 1, 0
7552	2, 1, 0
7542	4, 2, 1, 0
7532	4, 2, 1, 0
7502	4, 2, 1, 0
7502P	4, 2, 1
7452	4, 2, 1, 0
7402	4, 2, 1, 0
7402P	4, 2, 1
7352	4, 2, 1, 0
7302	4, 2, 1, 0
7302P	4, 2, 1
7282	1, 0

Table 8. Supported NPS modes by Processors (continued)

Model Number	NPS modes supported
7272	1, 0
7262	4, 2, 1, 0
7252	1, 0
7232P	1
7F72	2, 1, 0
7F52	4, 2, 1, 0
7F32	4, 2, 1, 0
7H12	4, 2, 1, 0
7713	4, 2, 1, 0
7543	4, 2, 1, 0
7763	4, 2, 1, 0
7413	4, 2, 1, 0
75F3	4, 2, 1, 0
7713P	4, 2, 1
7513	4, 2, 1, 0
7543P	4, 2, 1
7443P	4, 2, 1
7313P	4, 2, 1

 **NOTE:** NVIDIA GPU support is restricted to the processors which support NPS4.

Table 9. Optimal NPS configuration

Number of DIMMs per processor	NPS			
	0	1	2	4
1	-	-	-	X
2	-	-	-	X
3	-	-	-	X
4	-	X	-	-
5	-	-	-	X
6	-	-	-	X
7	-	-	-	X
8	X	X	-	-
9	-	-	-	X
10	-	-	-	X
11	-	-	-	X
12	-	-	X	-
13	-	-	-	X
14	-	-	-	X

Table 9. Optimal NPS configuration (continued)

Number of DIMMs per processor	NPS			
	0	1	2	4
15	-	-	-	X
16	X	X	-	-

- Recommended NPS setting is marked by X that indicate optimal performance.
- NPS0 is only available for dual processor systems and is the preferred setting.
- The NPS setting that are blank are functional. However, indicate non-optimal performance.
- BIOS default NPS setting is 1.
- UEFI0391 message may be displayed during boot if DIMMs are configured in the blank spaces of the table.
- If the processor does not support the desired NPS setting for a given number of DIMMs, then use default setting (NPS1) and the UEFI0391 message is displayed.

Memory interleaving population rules

- NPS4: Two channel interleaving
 - This interleaves channel [A and B], [C and D], etc.
 - Each channel within the pair requires at least one equal memory modules populated.
 - Works with three memory modules per channel pair, non-symmetrical module is stacked on top (odd configurations).
 - Any memory channel where one of the two channels is not populated is not interleaved.
 - There is no alternate, as all configurations can be mapped into this mode.
- NPS2: Four channel interleaving
 - This interleaves the four channels on the left or right half of a processor which are channels [A, B, C, D] and [E, F, G, H].
 - All four channels require equal memory modules populated.
 - Each half or interleave set may have different total memory capacity with respect to each other.
- NPS1: Eight channel interleaving
 - This interleaves all channels in a processor [A, B, C, D, E, F, G, H].
 - All channels in a processor require equal memory modules populated.
 - Single processor system creates a single NUMA node for the system.
 - ⓘ **NOTE:** An exception is allowed when system has 4-channels populated [C, D, G, H] with equal memory allowing the system to enter NPS1 mode even though all the 8 channels are not populated.
- NPS0: Sixteen channel interleaving (dual processor)
 - This interleaves all 16 channels in a dual processor system.
 - All channels in a system require equal memory modules populated.
 - Dual processor systems create a single NUMA node for the system.

System memory guidelines

The PowerEdge C6525 system supports DDR4 registered DIMMs (RDIMMs), load reduced DIMMs (LRDIMMs) and 3DS load reduced DIMMs (3DS LRDIMMs). System memory holds the instructions that are executed by the processor.

Your system contains 16 memory sockets organized into 8 channels per processor.

Memory channels are organized as follows:

Table 10. Memory channels

Processor	Channel A	Channel B	Channel C	Channel D	Channel E	Channel F	Channel G	Channel H
Processor 1	A6	A5	A2	A1	A8	A7	A4	A3
Processor 2	B6	B5	B2	B1	B8	B7	B4	B3

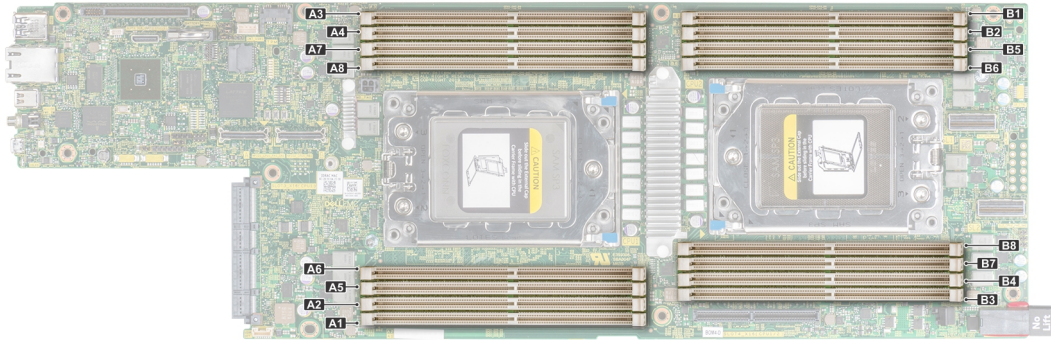

Figure 17. Memory socket location

Table 11. Supported memory matrix

DIMM type	Rank	Capacity	DIMM rated voltage and speed	DIMMs per Channel (DPC)
RDIMM	1R	8 GB	DDR4 (1.2V), 3200 MT/s	3200 MT/s
	2R	16 GB / 32 GB / 64 GB	DDR4 (1.2V), 3200 MT/s	3200 MT/s
LRDIMM	8R	128 GB	DDR4 (1.2V), 2666 MT/s	2666 MT/s
	8R	128 GB	DDR4 (1.2V), 3200 MT/s	3200 MT/s

NOTE: Mixing of memory module capacities in a system is not supported.

Removing a memory module

Prerequisites

1. Follow the safety guidelines listed in [Safety instructions](#).
2. Follow the procedure listed in [Before working inside your system](#).
3. [Remove the air shroud](#).

WARNING: Allow the memory modules to cool after you power off the system. Handle the memory modules by the card edges and avoid touching the components or metallic contacts on the memory module.

CAUTION: To ensure proper system cooling, memory module blanks must be installed in any memory socket that is not occupied. Remove memory module blanks only if you intend to install memory modules in those sockets.

Steps

1. Locate the appropriate memory module socket.

CAUTION: Handle each memory module only by the card edges, ensuring not to touch the middle of the memory module or metallic contacts.

2. Push the ejectors outward on both ends of the memory module socket to release the memory module from the socket.
3. Lift and remove the memory module from the system.

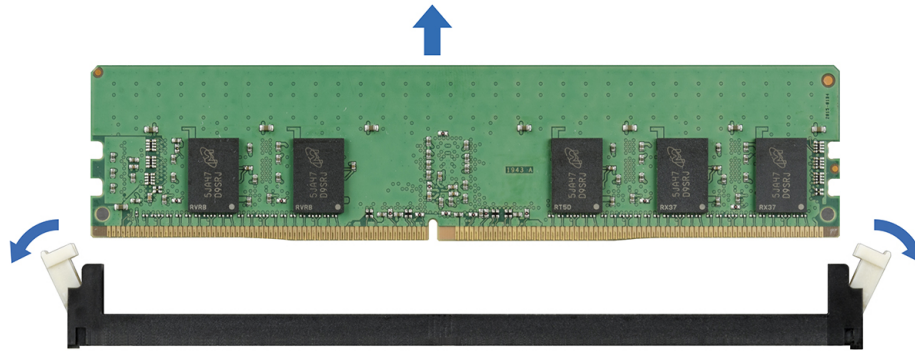

Figure 18. Removing a memory module

Next steps

1. [Install the memory module.](#)

CAUTION: If you are removing the memory module permanently, install a memory module blank. The procedure to install a memory module blank is similar to that of the memory module.

Installing a memory module

Prerequisites

1. Follow the safety guidelines listed in [Safety instructions](#).

Steps

1. Locate the appropriate memory module socket.

CAUTION: Handle each memory module only by the edges, ensuring not to touch the middle of the memory module or metallic contacts.

CAUTION: To prevent damage to the memory module or the memory module socket during installation, do not bend or flex the memory module. You must insert both ends of the memory module simultaneously.

2. Open the ejectors on the memory module socket outward to allow the memory module to be inserted into the socket.
3. Align the edge connector of the memory module with the alignment key of the memory module socket, and insert the memory module in the socket.

CAUTION: Do not apply pressure at the center of the memory module; apply pressure at both ends of the memory module evenly.

NOTE: The memory module socket has an alignment key that enables you to install the memory module in the socket in only one orientation.

4. Press the memory module with your thumbs until the socket levers firmly click into place.

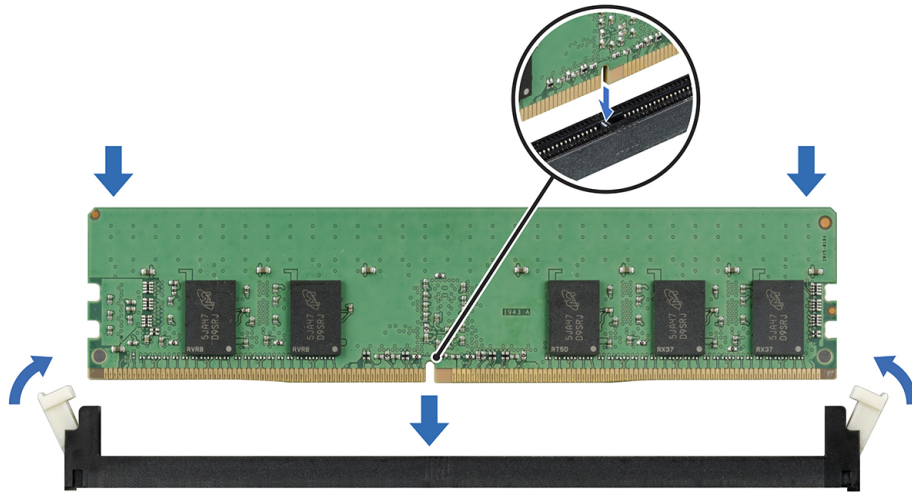

Figure 19. Installing a memory module

Next steps

1. [Install the air shroud.](#)
2. Follow the procedure listed in [After working inside your system.](#)
3. To verify if the memory module has been installed properly, press F2 and navigate to **System Setup Main Menu > System BIOS > Memory Settings**. In the **Memory Settings** screen, the System Memory Size must reflect the updated capacity of the installed memory.
4. If the value is incorrect, one or more of the memory modules may not be installed properly. Ensure that the memory module is firmly seated in the memory module socket.
5. Run the system memory test in system diagnostics.

Support bracket

Removing the support bracket

Prerequisites

1. Follow the safety guidelines listed in [Safety instructions.](#)
2. Follow the procedure listed in [Before working inside your system.](#)

Steps

1. Using the Phillips #1 screwdriver, remove the screws that secure the support bracket to the chassis.

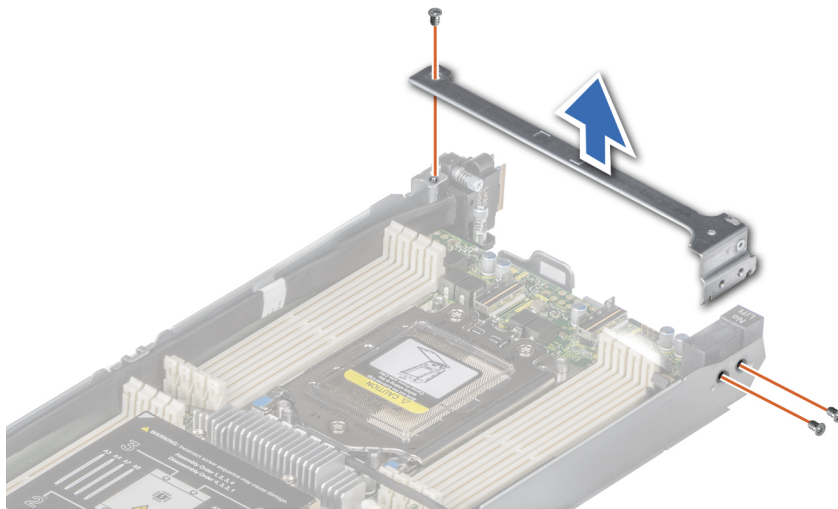

Figure 20. Removing the support bracket

2. Remove the support bracket from the chassis.

Next steps

1. [Install the support bracket.](#)

Installing the support bracket

Prerequisites

1. Follow the safety guidelines listed in [Safety instructions](#).

Steps

1. Align the support bracket with the stand off on the chassis.
2. Using a Phillips #1 screwdriver, secure the support bracket to the chassis.

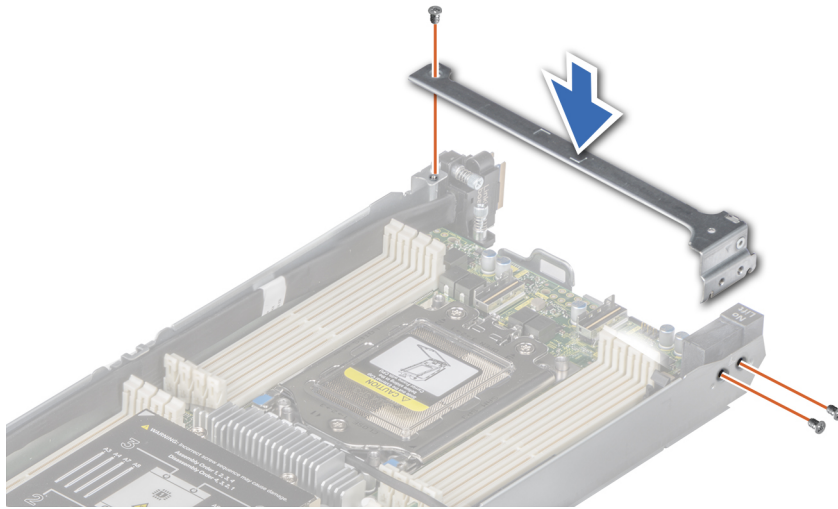

Figure 21. Installing the support bracket

Next steps

1. Follow the procedure listed in [After working inside your system.](#)

Expansion cards

NOTE: A missing or an unsupported expansion card riser logs an System Event Log (SEL) event. This does not prevent your system from powering on and no BIOS, POST messages or F1 or F2 pause is displayed.

Expansion card installation guidelines

The following table describes the supported expansion cards:

WARNING: Consumer-Grade GPU should not be installed or used in the Enterprise Server products.

PCIe slot priority

Table 12. Expansion card riser configurations

Riser options	Slot 1	Slot 2	Length	Height	Primary processor	Minimum processor requirement	Supported configurations
Riser 1A	Riser 1A PCIe Gen 4 x 16	NA	Half Length	Low Profile	1	1	<ul style="list-style-type: none"> • 12 x 3.5-inch drives • 24 x 2.5-inch drives • 8 x 2.5-inch NVMe drives • No backplane
Riser 1A+2A	Riser 1A PCIe Gen 4 x 16	Riser 2A PCIe Gen 4 x 16	Half Length	Low Profile	1 and 2	2	<ul style="list-style-type: none"> • 12 x 3.5-inch drives • 24 x 2.5-inch drives

Table 12. Expansion card riser configurations (continued)

Riser options	Slot 1	Slot 2	Length	Height	Primary processor	Minimum processor requirement	Supported configurations
							<ul style="list-style-type: none"> 8 x 2.5-inch NVMe drives No backplane
Riser 2A	NA	Riser 2A PCIe Gen 4 x 16	Half Length	Low Profile	2	2	<ul style="list-style-type: none"> 12 x 3.5-inch drives 24 x 2.5-inch drives 8 x 2.5-inch NVMe drives No backplane
No riser	NA	NA	Half Length	Low Profile	NA	1	<ul style="list-style-type: none"> 12 x 3.5-inch drives 24 x 2.5-inch drives 8 x 2.5-inch NVMe drives No backplane

The following table provides guidelines for installing expansion cards to ensure proper cooling and mechanical fit. The expansion cards with the highest priority should be installed first using the slot priority indicated. All the other expansion cards should be installed in the card priority and slot priority order.

Table 13. Riser configurations: No riser - Processor 1 and 2

Card Type	Slot Priority	Maximum number of cards
LOM riser ; 1G (Intel) (BAsE)T)	3	1
LOM riser ; 10G (Mellanox/Broadcom/QLogic) (BAsE)T/SFP/SFP+)	3	1
LOM riser ; 25G (QLogic/Mellanox/Intel)	3	1
BOSS S1V5 (Inventec)	4	1
Card,Network 10G (Broadcom) (BAsE)T)	3	1

Table 14. Riser configurations: Riser 1A - Processor 1 and 2

Card type	Slot priority	Maximum number of cards
LOM riser ; 1G (Intel/Broadcom) (BAsE)T)	3	1
LOM riser ; 10G (Broadcom/QLogic) (BAsE)T/SFP/SF+/SFP+)	3	1
LOM riser ; 25G (QLogic/Mellanox)	3	1
Card,Network 1G (Broadcom/Intel)	1	1
Card,Network 10G (Broadcom/Intel/QLogic)	1	1
Card,Network 10G (Broadcom) (BAsE)T)	3	1
Card,Network 25G (Broadcom/Intel/QLogic/Mellanox/SolarFlare)	1	1
Card,Network 100G (Mellanox/Intel)	1	1
GPU: Nvidia T4 16GB	2	1

Table 14. Riser configurations: Riser 1A - Processor 1 and 2 (continued)

Card type	Slot priority	Maximum number of cards
PCIe SSD (Samsung/Intel)	1	1
PERC 10: External Adapter (Inventec/ Foxconn)	1	1
HBA: External Adapter (Foxconn)	1	1
BOSS S1V5 (Inventec)	4	1
ASSY,CRD,CTL,H750,ADPT,250MM (Broadcom)	1	1
ASSY,CRD,CTL,H350,ADPT (Broadcom)	1	1
ASSY,CRD,CTL,H750,ADPT (Broadcom)	1	1

Table 15. Riser configurations: Riser 1A + Riser 2A - Processor 2

Card type	Slot priority	Maximum number of cards
LOM riser ; 1G (Intel/Broadcom) (BAsE)T)	3	1
LOM riser ; 10G (Broadcom/QLogic) (BAsE)T/SFP/SF+/SFP+)	3	1
LOM riser ; 25G (/QLogic/Mellanox)	3	1
Card,Network 1G (Broadcom/Intel)	1, 2	2
Card,Network 10G (Broadcom/Intel/ QLogic)	1, 2	2
Card,Network 10G (Broadcom) (BAsE)T)	3	1
Card,Network 25G (Broadcom/Intel/ QLogic/Mellanox/SolarFlare)	1, 2	2
Card,Network 100G (Mellanox/Intel)	1, 2	2
GPU: Nvidia T4 16GB	2	1
PCIe SSD (Samsung/Intel)	1, 2	2
PERC 10: External Adapter (Inventec/ Foxconn)	1	1
HBA: External Adapter (Foxconn)	1	1
BOSS S1V5 (Inventec)	4	1
ASSY,CRD,CTL,H750,ADPT,250MM (Broadcom)	1	1
ASSY,CRD,CTL,H350,ADPT (Broadcom)	1	1
ASSY,CRD,CTL,H750,ADPT (Broadcom)	1	1

Table 16. Riser configurations: Riser 2A - Processor 2

Card type	Slot priority	Maximum number of cards
LOM riser ; 1G (Intel/Broadcom) (BAsE)T)	3	1
LOM riser ; 10G (Broadcom/QLogic) (BAsE)T/SFP/SF+/SFP+)	3	1
LOM riser ; 25G (QLogic/Mellanox)	3	1

Table 16. Riser configurations: Riser 2A - Processor 2 (continued)

Card type	Slot priority	Maximum number of cards
Card,Network 1G (Broadcom/Intel)	2	1
Card,Network 10G (Broadcom/Intel/QLogic)	2	1
Card,Network 10G (Broadcom) (BAsE-T)	3	1
Card,Network 25G (Broadcom/Intel/QLogic/Mellanox/SolarFlare)	2	1
Card,Network 100G (Mellanox/Intel)	2	1
GPU: Nvidia T4 16GB	2	1
PCIe SSD (Samsung/Intel)	2	1
BOSS S1V5 (Inventec)	4	1

Removing the expansion card riser 1

Prerequisites

i **NOTE:** Install an expansion card filler bracket over an empty expansion slot to maintain Federal Communications Commission (FCC) certification of the system. The brackets also keep dust and dirt out of the system and aid in proper cooling and airflow inside the system.

1. Follow the safety guidelines listed in [Safety instructions](#).
2. Follow the procedure listed in [Before working inside your system](#).

Steps

1. Using a Phillips #1 screw driver, remove the screws that secure the expansion card riser 1.
2. Holding the blue touch point, remove the expansion card riser from the chassis.

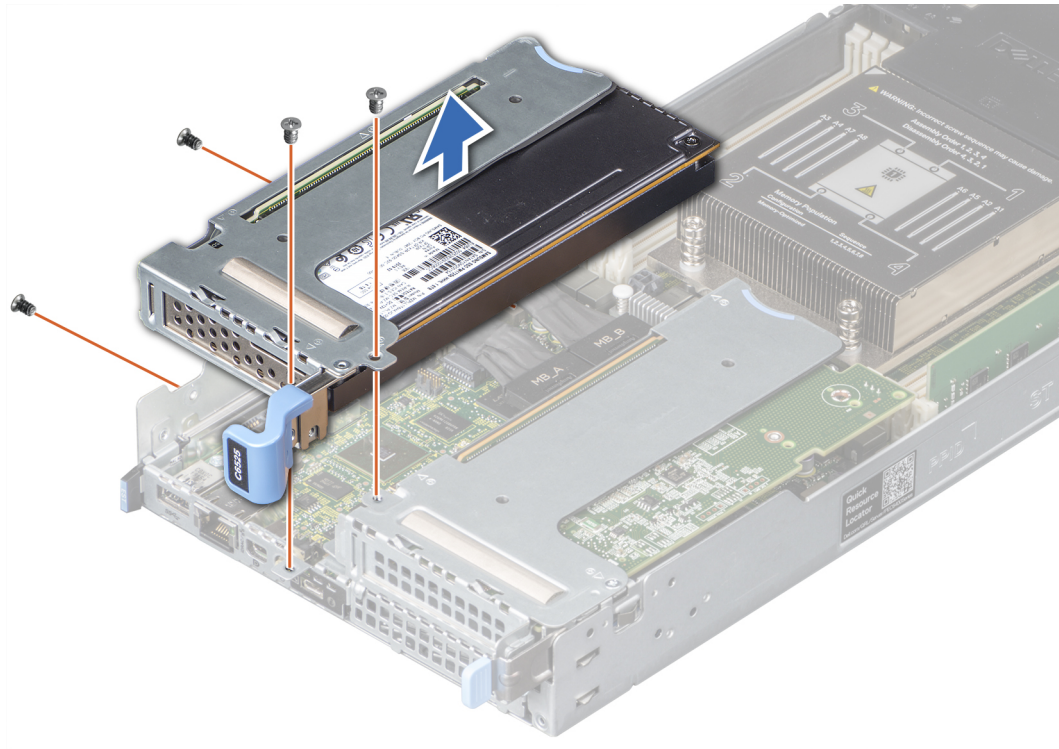

Figure 22. Removing the expansion card riser 1

Next steps

1. Install the expansion card riser 1.

Installing the expansion card riser 1

Prerequisites

NOTE: You must install an expansion card filler bracket over an empty expansion slot to maintain Federal Communications Commission (FCC) certification of the system. The brackets also keep dust and dirt out of the system and aid in proper cooling and airflow inside the system.

1. Follow the safety guidelines listed in [Safety instructions](#).
2. Follow the procedure listed in [Before working inside your system](#).

Steps

1. Align the screw holes on the riser with the screw holes on the chassis.
2. Lower the riser until the riser card is firmly seated in the slot.
3. Using a Phillips #1 screwdriver, tighten the screws that secure the expansion card riser 1.

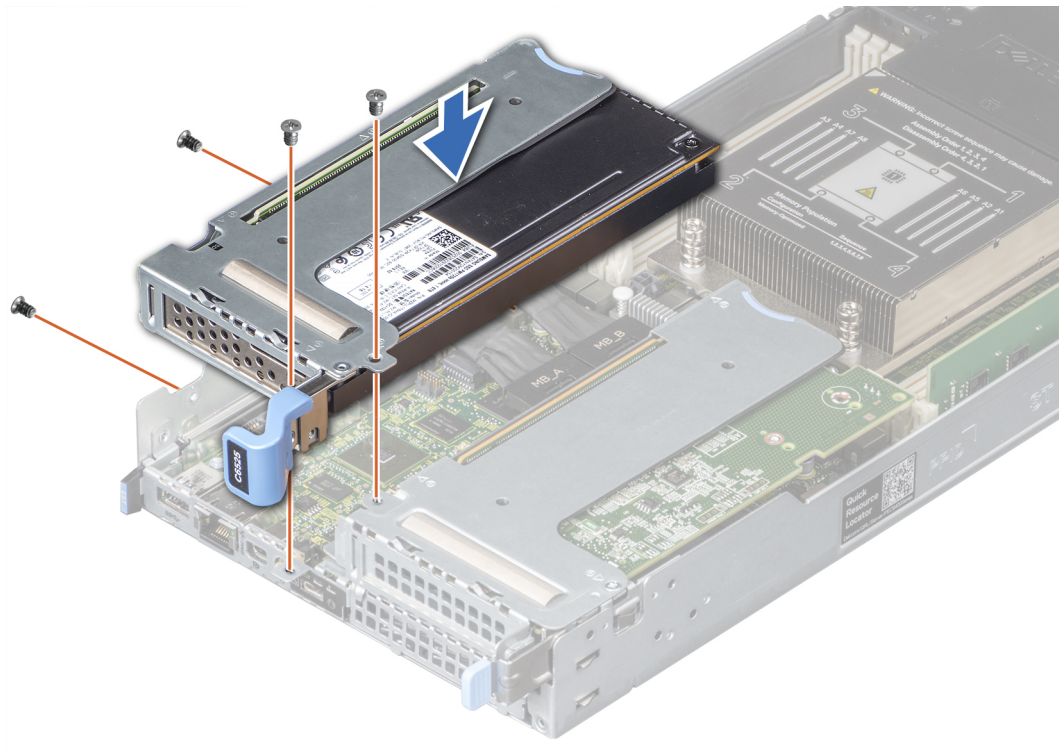

Figure 23. Installing the expansion card riser 1

Next steps

1. Follow the procedure listed in [After working inside your system](#).

Removing the expansion card riser 2

Prerequisites

NOTE: Install an expansion card filler bracket over an empty expansion slot to maintain Federal Communications Commission (FCC) certification of the system. The brackets also keep dust and dirt out of the system and aid in proper cooling and airflow inside the system.

1. Follow the safety guidelines listed in [Safety instructions](#).
2. Follow the procedure listed in [Before working inside your system](#).
3. [Remove the expansion card riser 1](#).

Steps

1. If applicable, disconnect the **MB_SL1** and **MB_SL2** connector.
 - a. To remove the **MB_SL1** and **MB_SL2** connector, hold and pull the blue pull tab.
2. Using Phillips #1 screw driver, remove the screws that secure the expansion card riser 2.
3. Holding the blue touch point, remove the expansion card riser from the chassis.

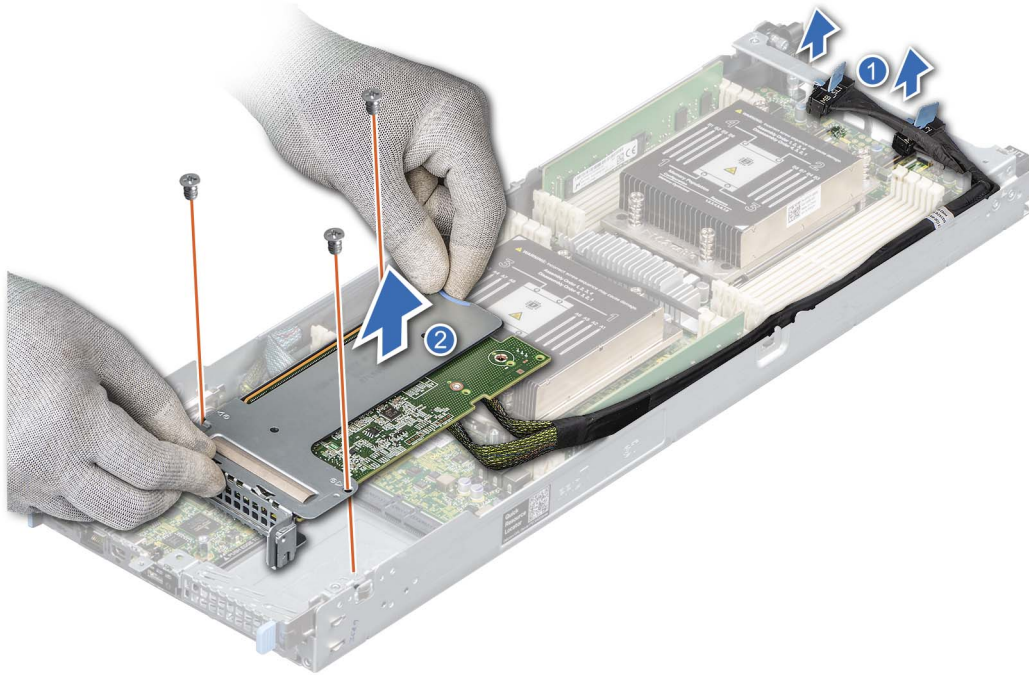

Figure 24. Removing the expansion card riser 2

Next steps

1. [Install the expansion card riser 2.](#)

Installing the expansion card riser 2

Prerequisites

NOTE: You must install an expansion card filler bracket over an empty expansion slot to maintain Federal Communications Commission (FCC) certification of the system. The brackets also keep dust and dirt out of the system and aid in proper cooling and airflow inside the system.

1. Follow the safety guidelines listed in [Safety instructions](#).
2. Follow the procedure listed in [Before working inside your system](#).

Steps

1. Align the screw holes on the riser with the stand offs on the system board and insert it until the riser card is firmly seated in the slot..
2. Using a Phillips #1 screwdriver, tighten the screws that secure the expansion card riser 2.

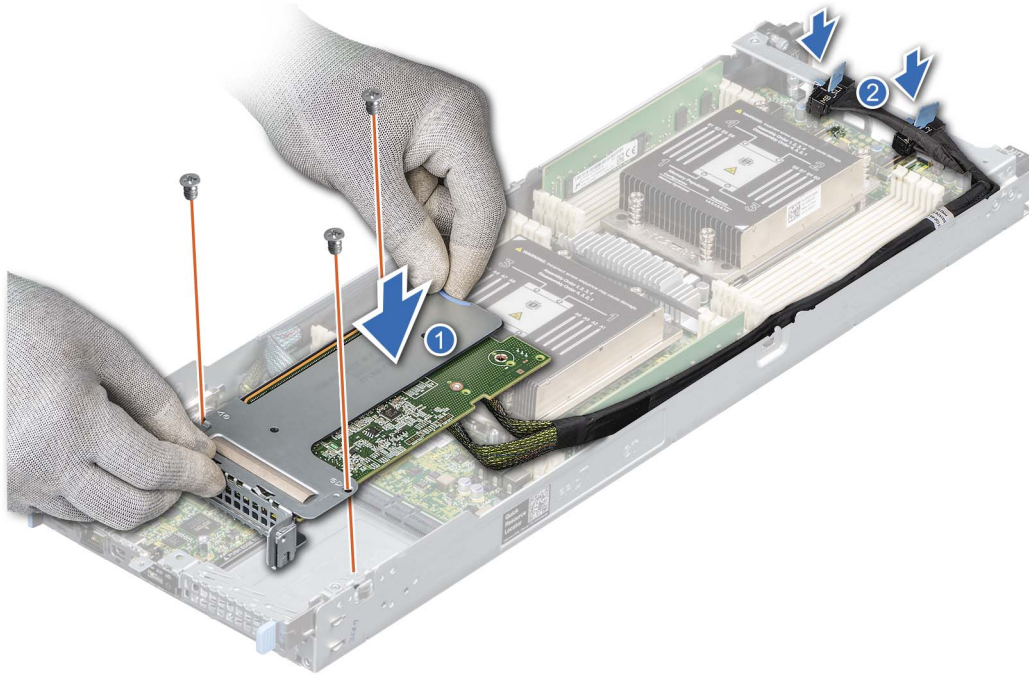

Figure 25. Installing the expansion card riser 2

3. If applicable, connect the **MB_SL1** and **MB_SL2** connector.
 - a. To connect the **MB_SL1** and **MB_SL2** connector, press the connector until it is firmly seated.

Next steps

1. [Install the expansion card riser 1.](#)
2. Follow the procedure listed in [After working inside your system.](#)

Removing an expansion card

Prerequisites

1. Follow the safety guidelines listed in [Safety instructions.](#)
2. Follow the procedure listed in [Before working inside your system.](#)
3. [Remove the expansion card riser.](#)

Steps

1. Using a Phillips #2 screwdriver, remove the screw that secures the expansion card to the riser.
2. Holding the expansion card by its edges, remove it from the riser.

i **NOTE:** Install an expansion card filler bracket over an empty expansion slot to maintain Federal Communications Commission (FCC) certification of the system. The brackets also keep dust and dirt out of the system and aid in proper cooling and airflow inside the system.

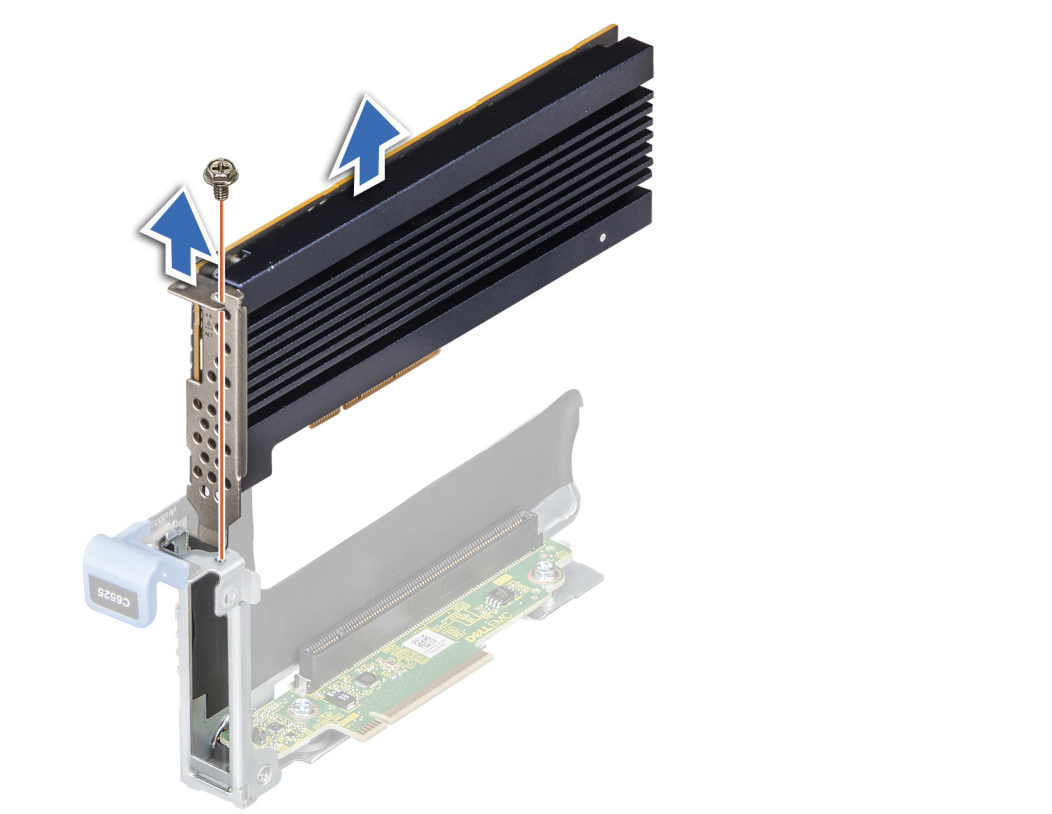

Figure 26. Removing an expansion card from riser 1

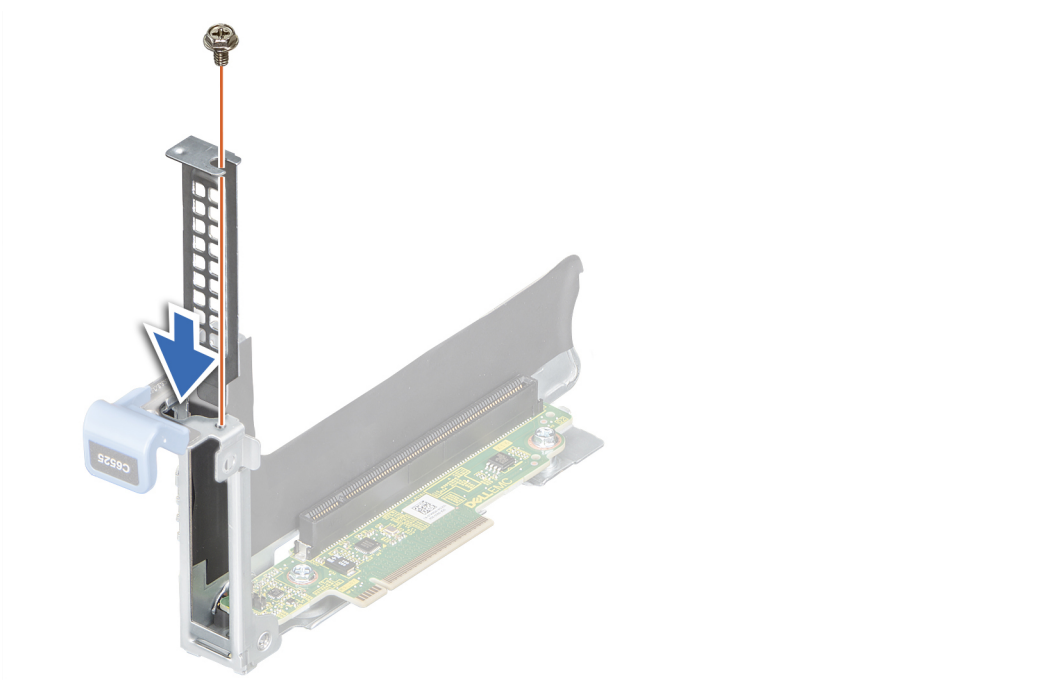

Figure 27. Installing the expansion card filler bracket in riser 1

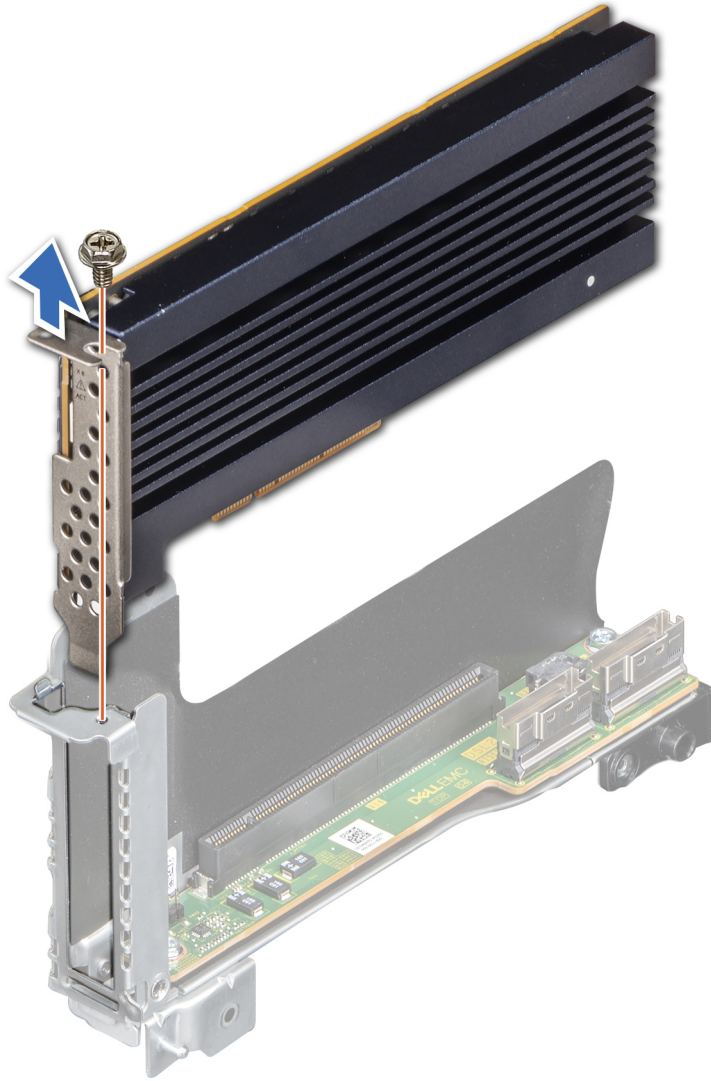

Figure 28. Removing an expansion card from riser 2

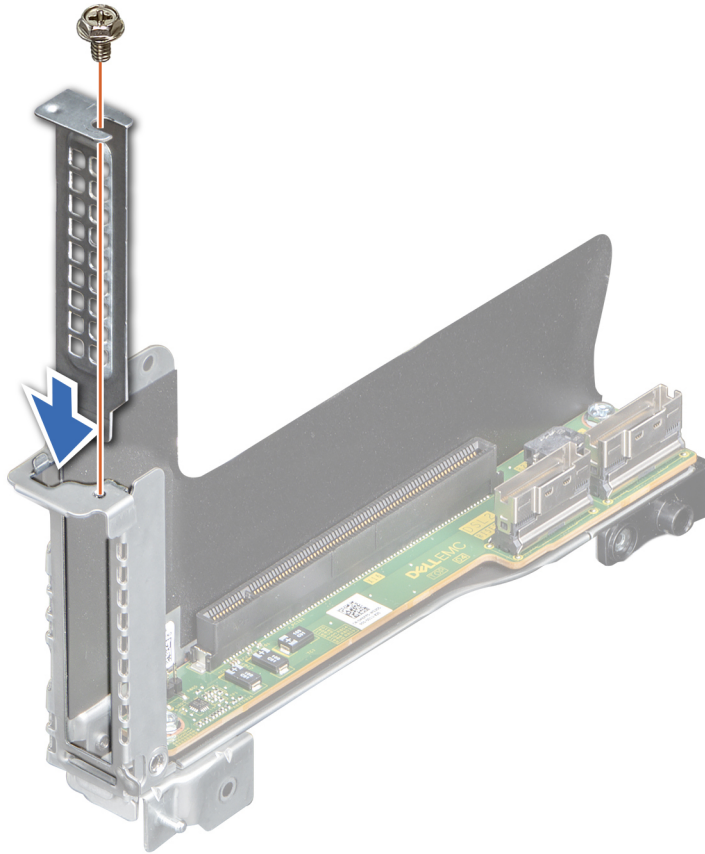

Figure 29. Installing the expansion card filler bracket in riser 2

Next steps

1. [Install the expansion card.](#)

Installing an expansion card

Prerequisites

CAUTION: Expansion cards can only be installed in the slots on the expansion card riser. Do not attempt to install expansion cards directly into the riser connector on the system board.

1. Follow the safety guidelines listed in [Safety instructions](#).
2. Unpack the expansion card and prepare it for installation. For instructions, see the documentation accompanying the card.

Steps

1. If installed, remove the filler bracket by performing the following steps:
 - a. Remove the screw that secures the filler bracket.
 - b. Hold the filler bracket by its edges, and remove it from the riser.

NOTE: You must install an expansion card filler bracket over an empty expansion slot to maintain Federal Communications Commission (FCC) certification of the system. The brackets also keep dust and dirt out of the system and aid in proper cooling and airflow inside the system.

2. Holding the card by its edges, align the card with the slot on the riser.
3. Insert the card until it is fully seated in the slot.
4. Replace the screw that secures the expansion card.

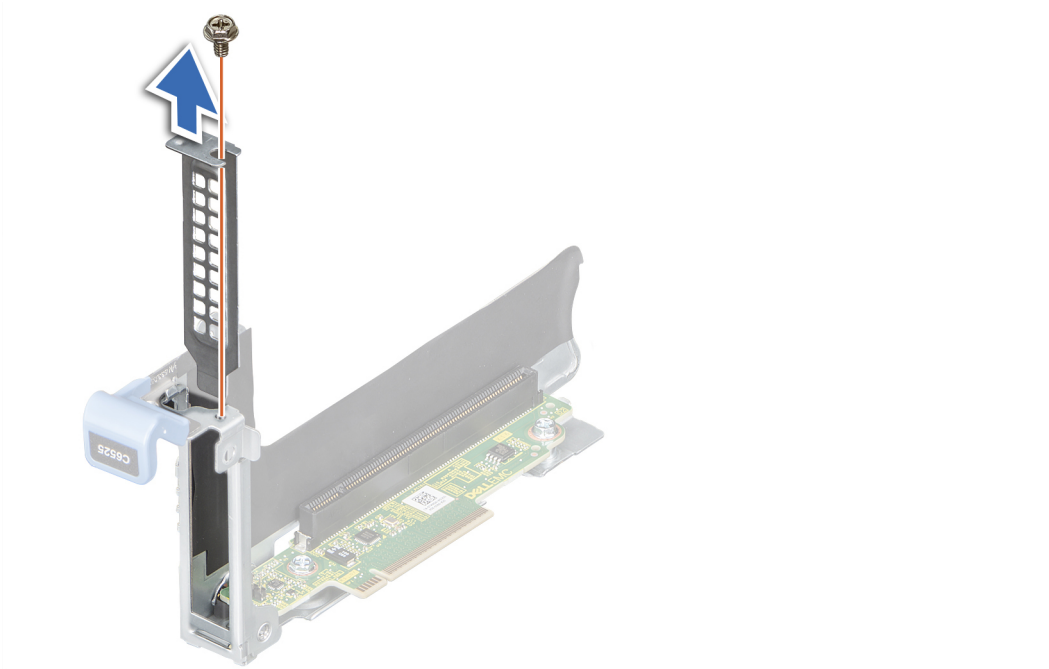

Figure 30. Removing the expansion card filler bracket

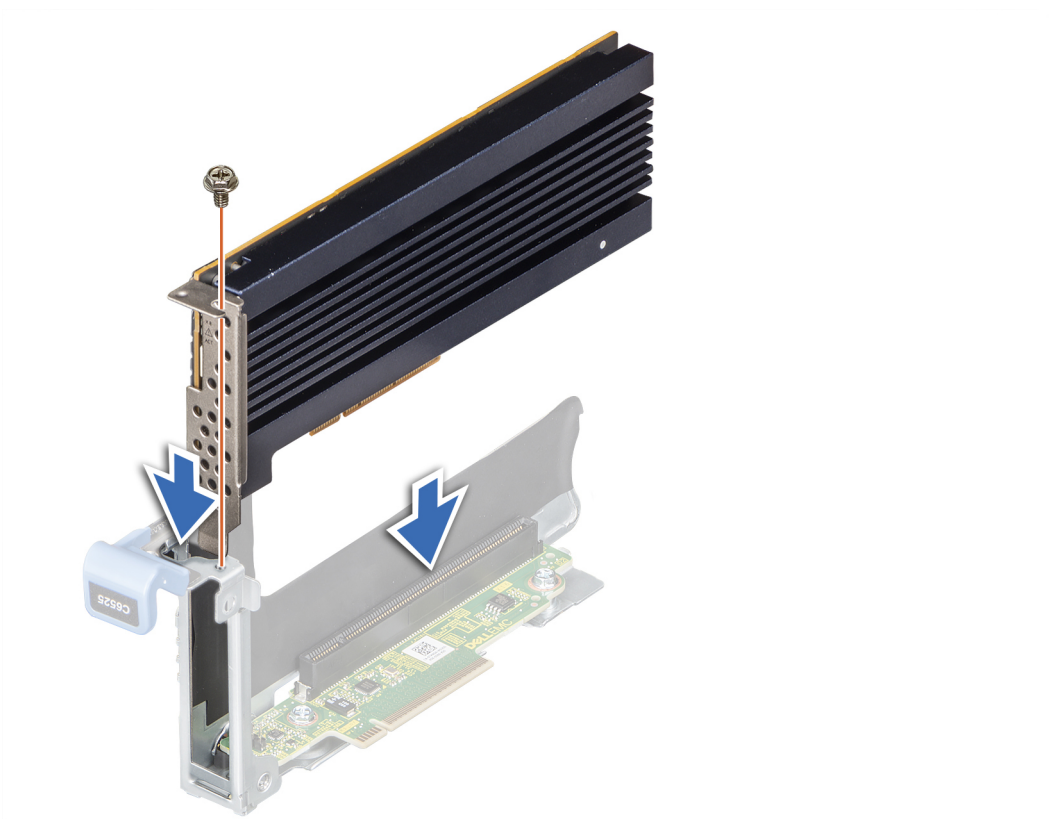

Figure 31. Installing an expansion card in riser 1

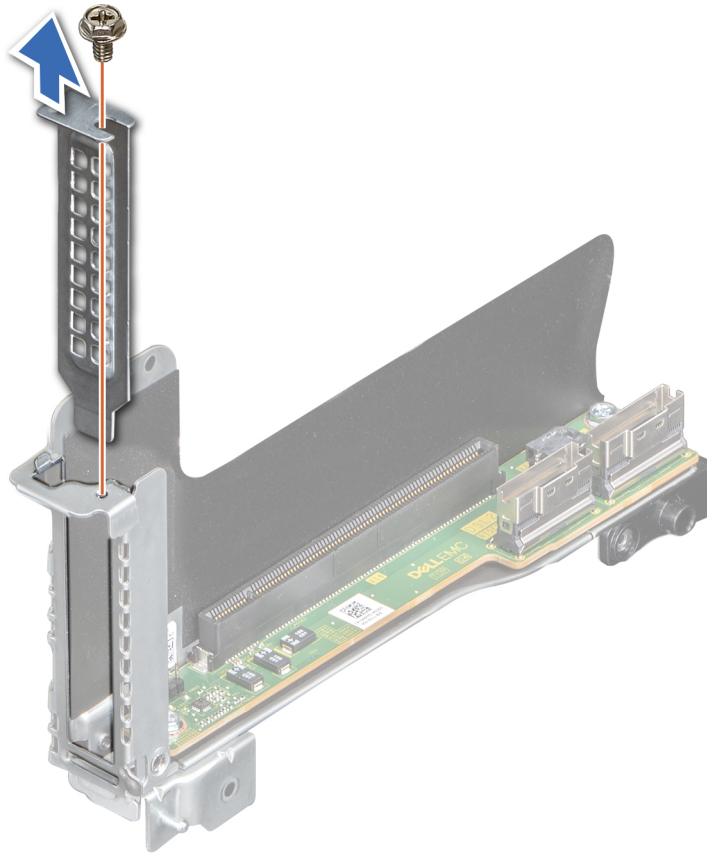

Figure 32. Removing the expansion card filler bracket

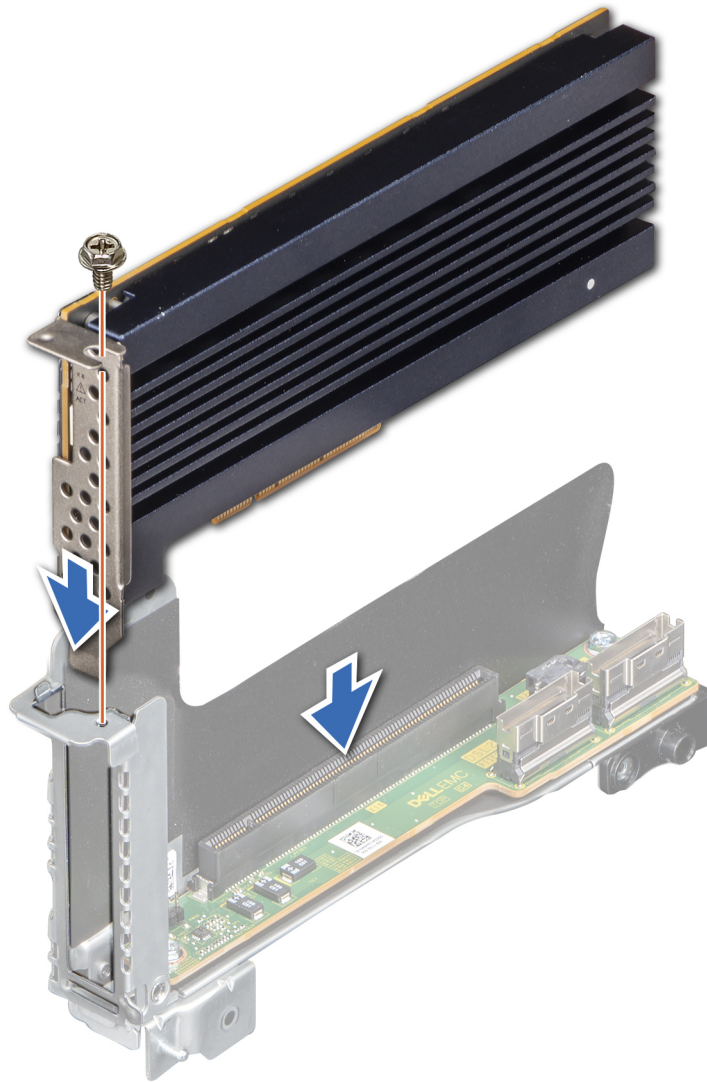

Figure 33. Installing an expansion card in riser 2

Next steps

1. [Install the expansion card riser.](#)
2. Follow the procedure listed in [After working inside your system.](#)

Removing the riser card

Prerequisites

1. Follow the safety guidelines listed in [Safety instructions.](#)
2. Follow the procedure listed in [Before working inside your system.](#)
3. [Remove the expansion card riser.](#)
4. If installed, [remove the expansion card.](#)
5. If applicable, disconnect the cable from the riser card.

Steps

1. Using a Phillips #2 screwdriver, remove the screws that secure the riser card to the expansion card riser.

2. Remove the riser card from the expansion card riser.

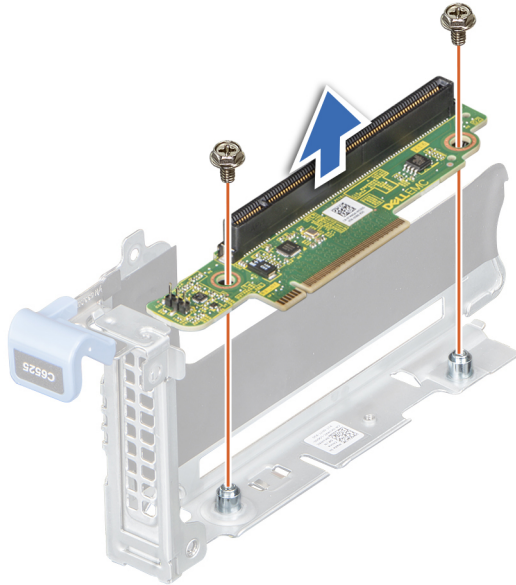

Figure 34. Removing the riser card from riser 1

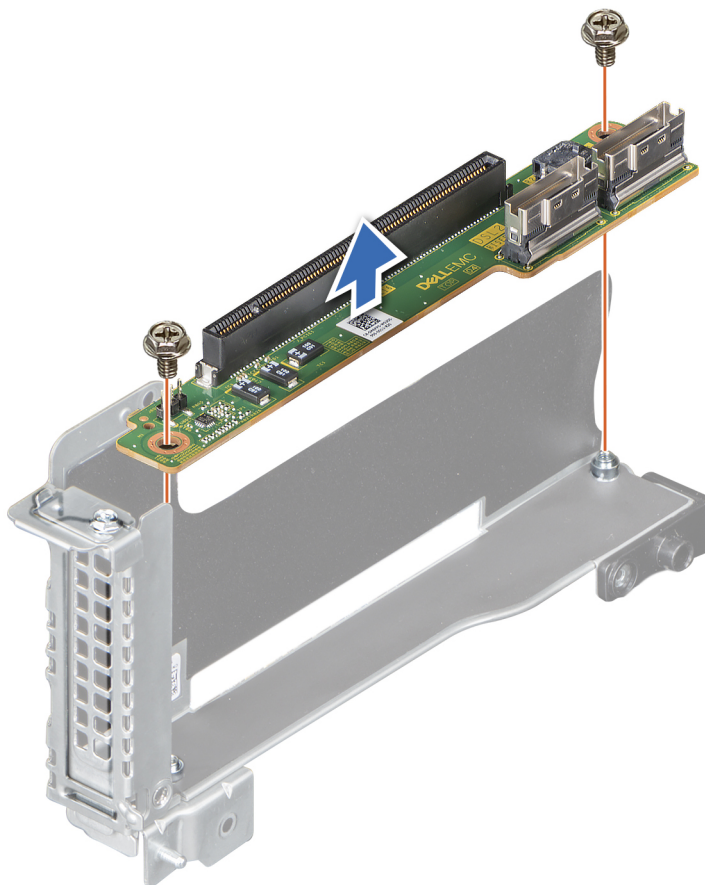

Figure 35. Removing the riser card from riser 2

Next steps

1. Install the riser card.

Installing the riser card

Prerequisites

1. Follow the safety guidelines listed in [Safety instructions](#).
2. Follow the procedure listed in [Before working inside your system](#).

Steps

1. Align and insert the riser card with the screw holes on the riser.
2. Using a Phillips #2 screwdriver, tighten the screws that secure the riser card to the expansion card riser.

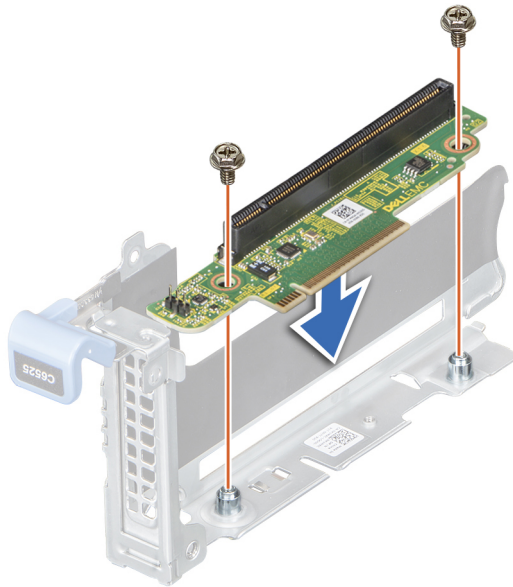

Figure 36. Installing the riser card in riser 1

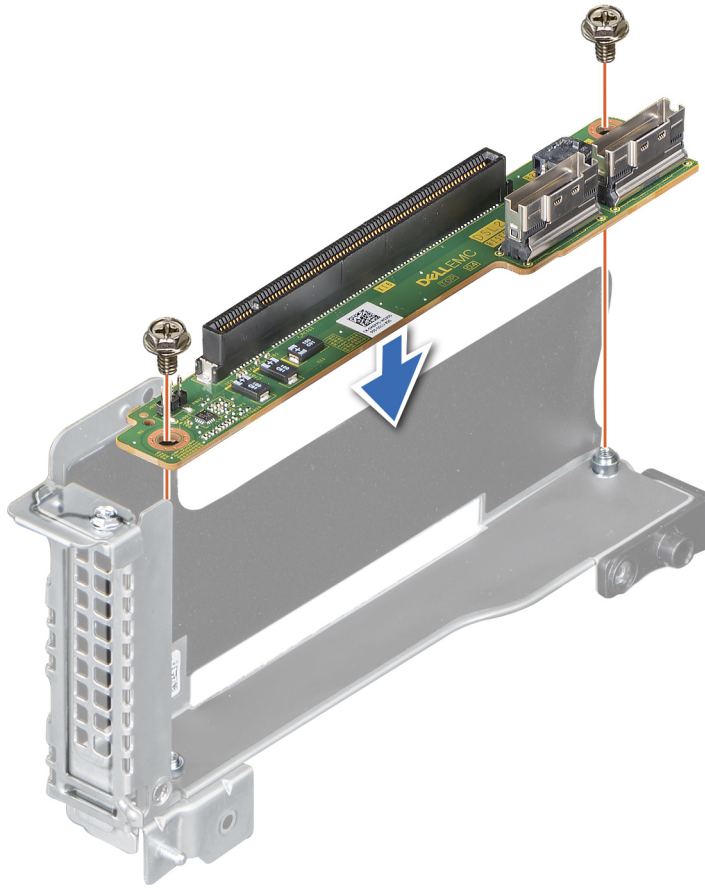

Figure 37. Installing the riser card in riser 2

Next steps

1. If applicable, connect the cable to the riser card.
2. If removed, [install the expansion card](#).
3. [Install the expansion card riser](#).
4. Follow the procedure listed in [After working inside your system](#).

M.2 riser

Removing the M.2 riser

Prerequisites

1. Follow the safety guidelines listed in [Safety instructions](#).
2. Follow the procedure listed in [Before working inside your system](#).
3. [Remove the air shroud](#).

Steps

1. Using a Phillips #2 screwdriver, loosen the screw that secures the riser to the chassis.
2. Lift the riser to disengage the riser from the connector on the system board.
3. Disconnect the data cable from the riser.

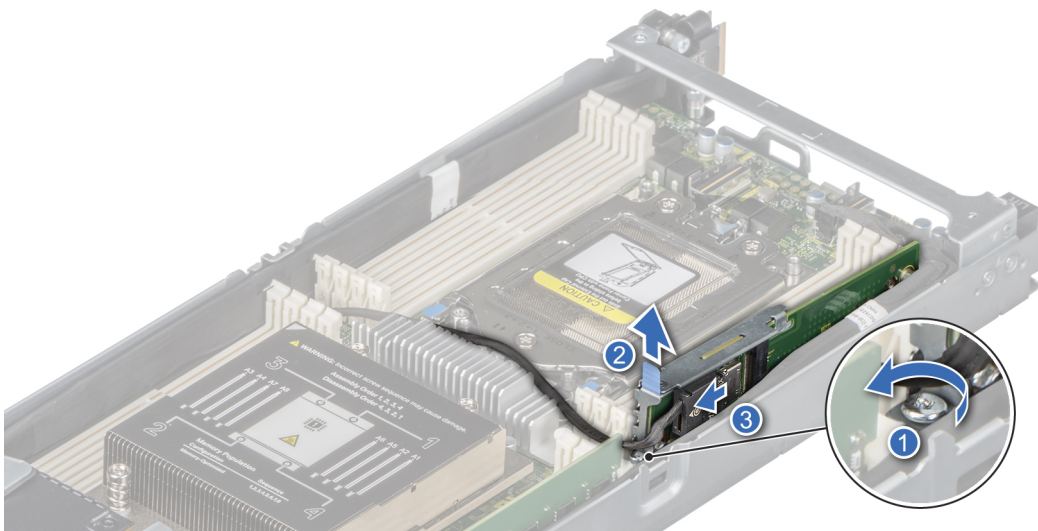

Figure 38. Removing the M.2 riser

Next steps

1. [Install the M.2 riser.](#)

Installing the M.2 riser

Prerequisites

1. Follow the safety guidelines listed in [Safety instructions](#).
2. Follow the procedure listed in [Before working inside your system](#).
3. [Remove the air shroud.](#)

Steps

1. Connect the data cable to the M.2 riser.
2. Align the M.2 riser with the stand off on the system board and insert it until the card is firmly seated in the slot.
3. Using a Phillips #2 screwdriver, tighten the screw that secures the riser to the chassis.

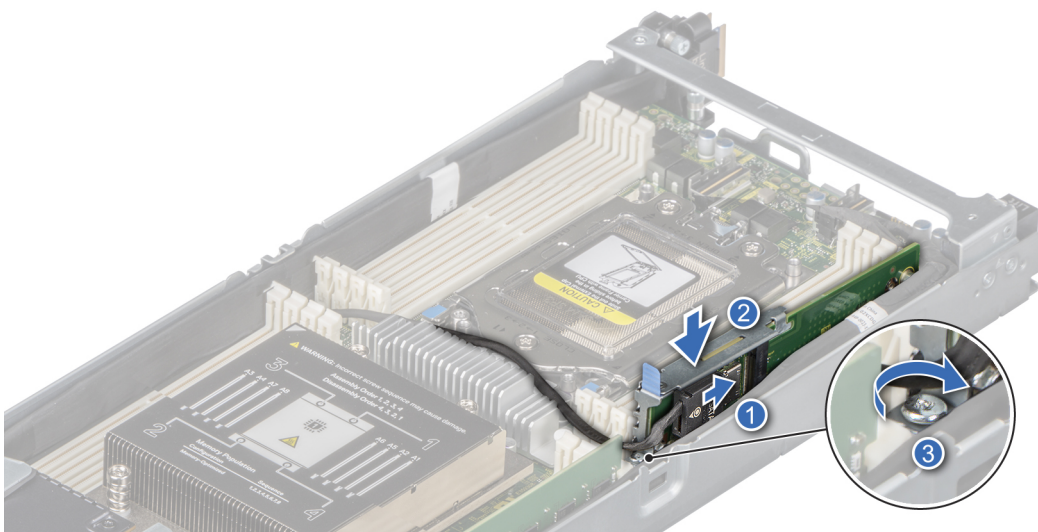

Figure 39. Installing the M.2 riser

Next steps

1. [Replace the air shroud.](#)
2. Follow the procedure listed in [After working inside your system.](#)

M.2 SSD module

Removing the M.2 SSD module

Prerequisites

1. Follow the safety guidelines listed in [Safety instructions.](#)
2. Follow the procedure listed in [Before working inside your system.](#)
3. [Remove the M.2 riser.](#)

Steps

1. Using a Phillips #1 screwdriver, remove the screws securing the M.2 SSD module to the M.2 riser.
2. Pull the M.2 SSD module to disconnect from the connector on the M.2 riser.

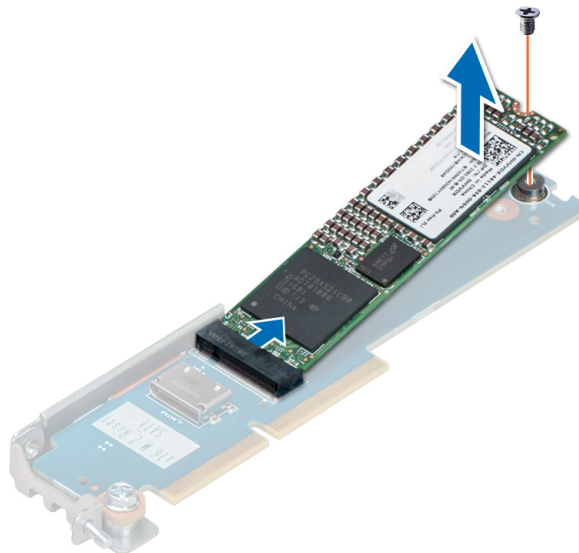

Figure 40. Removing the M.2 SATA card from the M.2 riser

Next steps

1. [Install the M.2 SSD module.](#)

Installing the M.2 SSD module

Prerequisites

1. Follow the safety guidelines listed in [Safety instructions.](#)
2. Follow the procedure listed in [Before working inside your system.](#)

NOTE: The procedure to remove the BOSS card is similar to the removing an expansion card.

Steps

1. Align the M.2 SSD module at an angle with the connector on the M.2 riser.

2. Insert the M.2 SSD module until it is firmly seated in the connector on the M.2 riser.

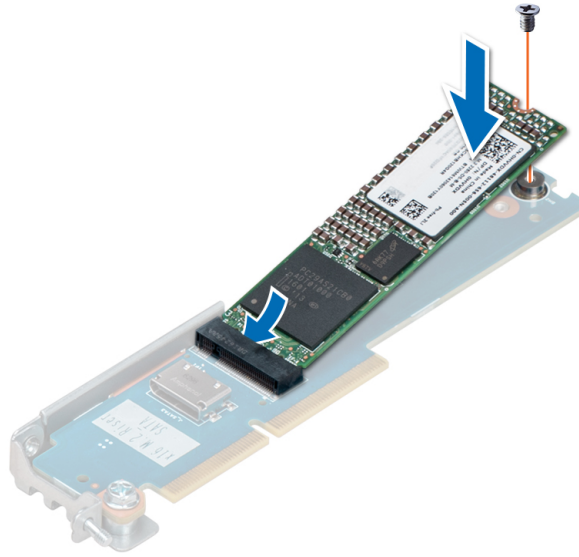

Figure 41. Installing the M.2 SATA card on the M.2 riser

3. Using a Phillips #1 screwdriver, secure the M.2 SSD module on the M.2 riser with the screw.

Next steps

1. [Install the M.2 riser.](#)
2. Follow the procedure listed in [After working inside your system.](#)

Linking board and PCIe cable

Removing the linking board and PCIe cable

Prerequisites

i **NOTE:** Observe the routing of the cable as you remove it from the sled. Route the cable properly when you replace it to prevent the cable from being pinched or crimped.

1. Follow the safety guidelines listed in [Safety instructions.](#)
2. Follow the procedure listed in [Before working inside your system.](#)
3. [Remove the air shroud.](#)
4. [Remove the support bracket.](#)
5. [Remove the expansion riser 1.](#)

Steps

1. To disconnect the MB cable, press the release button on the MB_A cable connector and lift it. See the [System board connector](#) for more information.
2. Remove the MB_B cable.

i **NOTE:** The procedure to remove the MB_B cable is similar to removing the MB_A cable.

3. If applicable, disconnect the M.2 riser data cable from the M.2 riser.
4. Using a Phillips #2 screwdriver, loosen the captive screws that secure the linking board to the chassis.

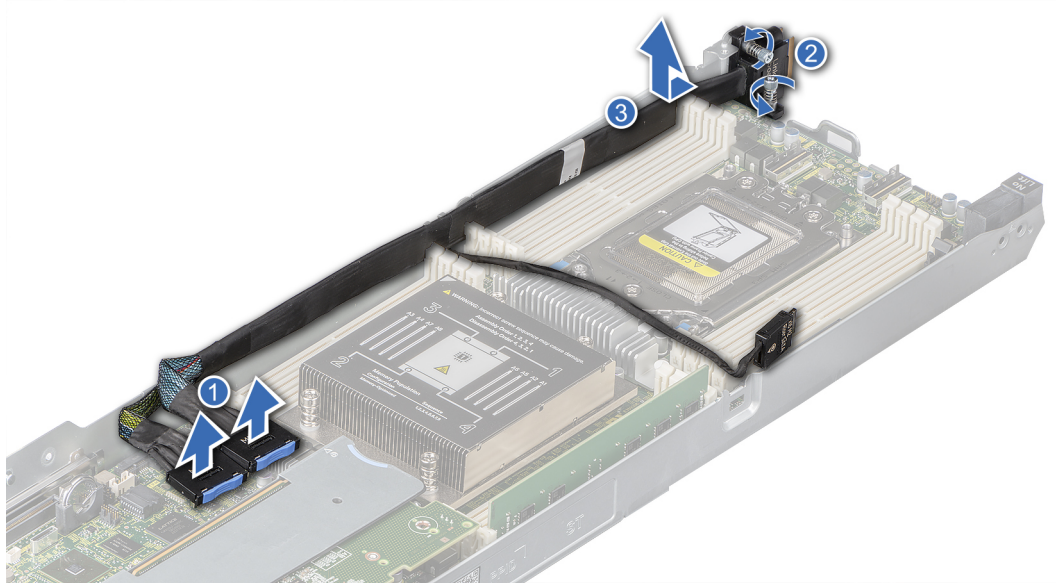

Figure 42. Removing the linking board and SATA cable

5. To disengage the linking board connector, lift and push the MB_cable towards the front of the sled.
6. Remove the MB cable from the sled.

Next steps

1. [Install the linking board and PCIe cable.](#)

Installing the linking board and PCIe cable

Prerequisites

1. Follow the safety guidelines listed in [Safety instructions](#).
2. Follow the procedure listed in [Before working inside your system](#).

Steps

1. Route the MB cable along the chassis wall.
2. Align the linking board connector with the screw holes on the chassis and using a Phillips #2 screw driver tighten the captive screws to secure the linking board cable connector to the chassis.
3. Connect the MB connectors to the connectors on the system board.

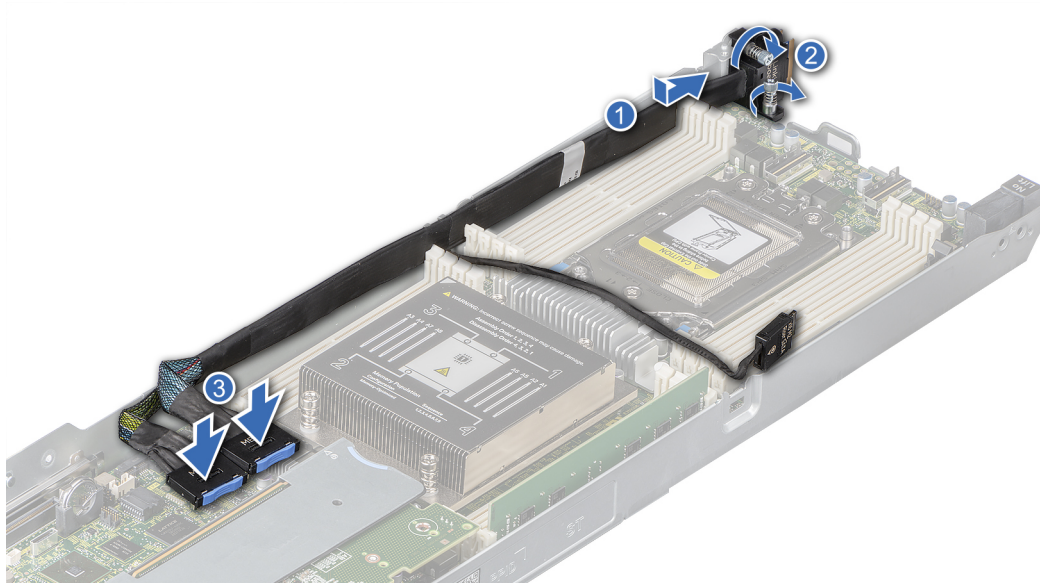

Figure 43. Installing the linking board and SATA cable

4. If applicable, connect the M.2 riser data cable to the M.2 riser.

Next steps

1. Install the expansion card riser 1.
2. Install the support bracket.
3. Install the air shroud.
4. Follow the procedure listed in [After working inside your system](#).

Processor and heat sink

Removing the heat sink

Prerequisites

1. Follow the safety guidelines listed in the [Safety instructions](#).
2. Follow the procedure listed in the [Before working inside your system](#).
3. [Remove the air shroud](#).

NOTE: The heat sink and processor are too hot to touch for some time after the system has been powered down. Allow the heat sink and processor to cool down before handling them.

Steps

1. Using a Torx #T20 screwdriver, loosen the captive screws in the order mentioned on the heatsink:
 - a. Partially loosen the captive screws 4 and 3 (approximately 3 turns).
 - b. Partially loosen the captive screws 2 and 1 (approximately 3 turns).
 - c. Loosen the captive screws 4 and 3 completely.
 - d. Loosen the captive screws 2 and 1 completely.
2. Lift the heat sink from the system.

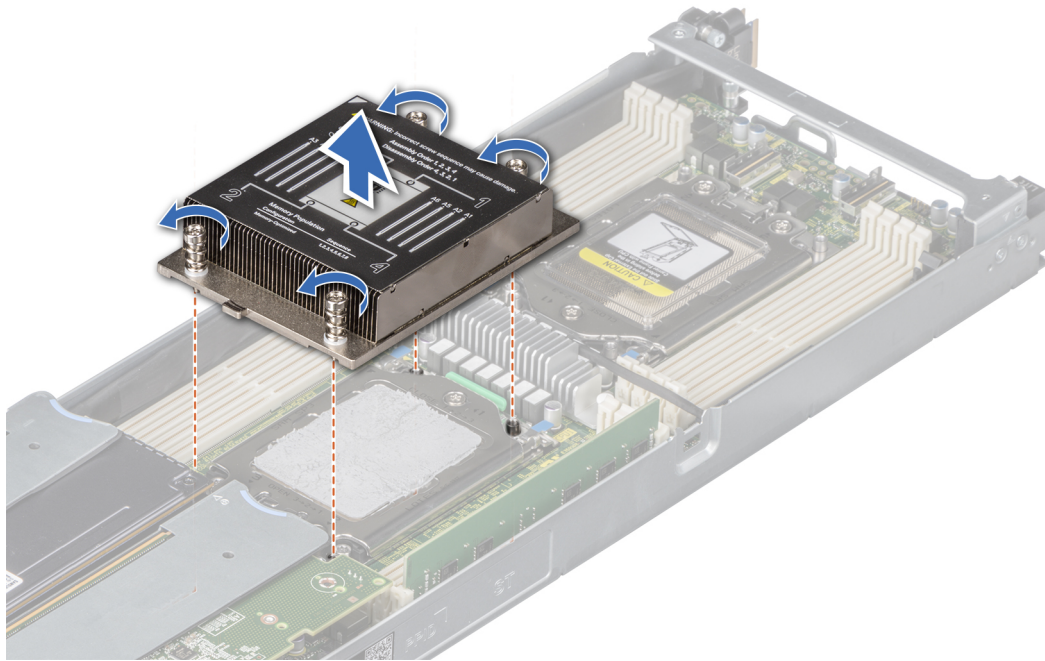

Figure 44. Removing the heat sink

Next steps

1. If you are removing a faulty heat sink, [replace the heat sink](#), if not, [remove the processor](#).

Removing the processor

Prerequisites

CAUTION: The heat sink may be hot to touch for some time after the system has been powered off. Allow the heat sink to cool before removing it.

1. Follow the procedure in [Safety instructions](#).
2. Follow the procedure listed in the [Before working inside your system](#).
3. [Remove the air shroud](#).
4. [Remove the heat sink](#).

Steps

1. Using a Torx #T20 screwdriver, loosen the screws to release the force plate. The sequence to loosen the screws is 3, 2, and 1.

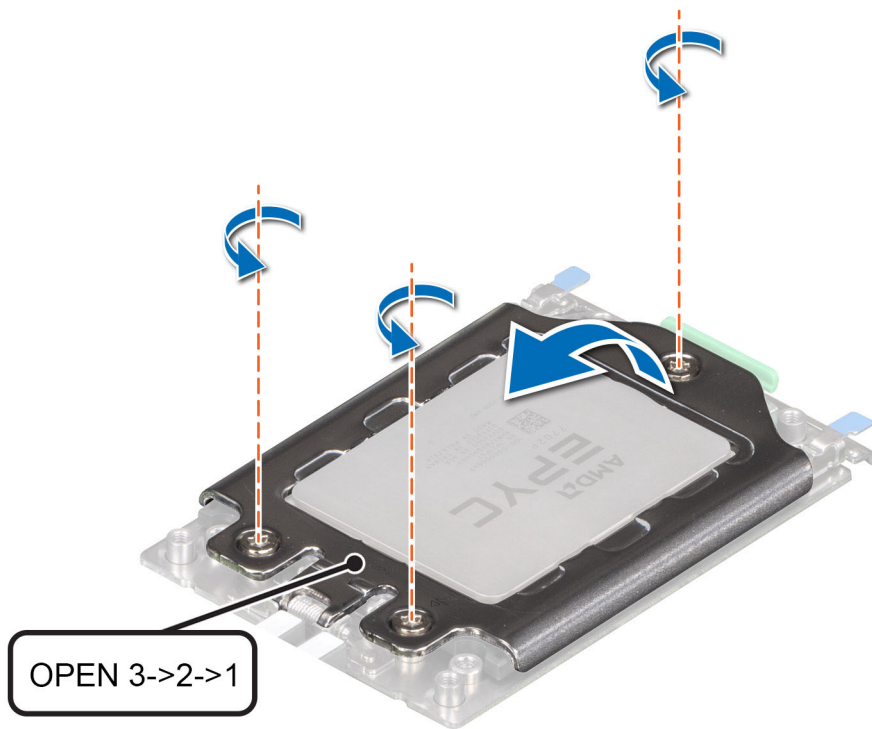

Figure 45. Removing screws on the force plate

2. Release the processor socket rail frame by lifting up the blue latches.

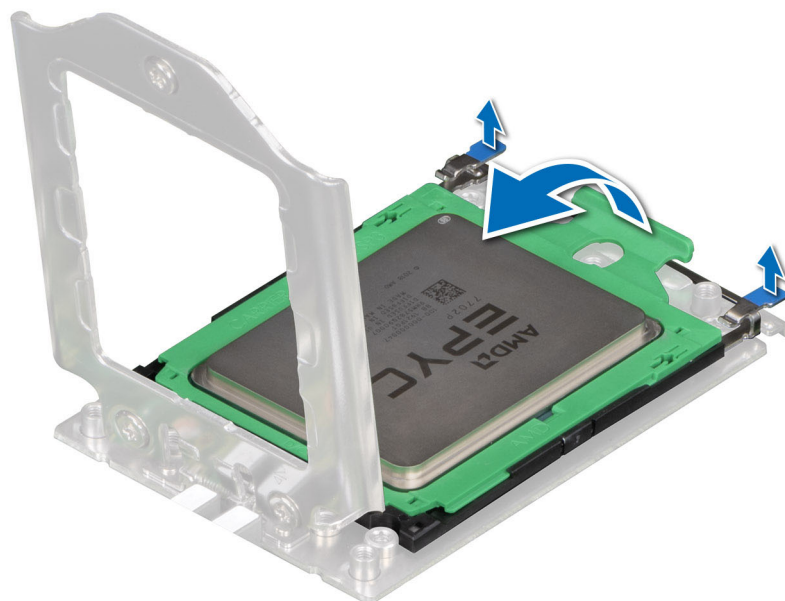

Figure 46. Lifting the rail frame

3. Holding the blue tab on the processor tray, slide the tray out of the rail frame.

CAUTION: The processor socket pins are fragile and can be permanently damaged. Ensure not to bend the pins in the processor socket while handling the processor.

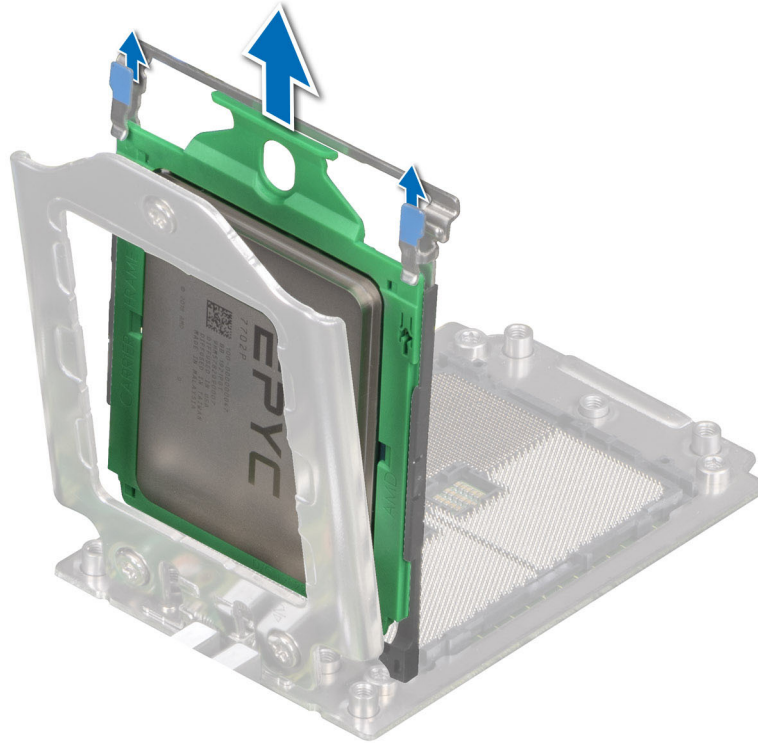

Figure 47. Removing the processor tray

Next steps

1. [Replace the processor.](#)

Installing the processor

Prerequisites

1. Follow the safety guidelines listed in the [Safety instructions](#).
2. Follow the procedure in [Before working inside your system](#).
3. [Remove the air shroud](#).
4. [Remove the heat sink](#).
5. If the processor has previously been used in a system, remove any remaining thermal grease from the processor by using a lint-free cloth.
6. Use the thermal grease syringe included with your processor kit to apply the grease in a quadrilateral design on the top of the processor.

CAUTION: Applying too much thermal grease can result in excess grease coming in contact with and contaminating the processor socket.

NOTE: The thermal grease syringe is intended for single use only. Dispose the syringe after you use it.

Steps

1. Holding the blue tab on the processor tray, slide the tray into the processor socket rail frame until firmly seated.

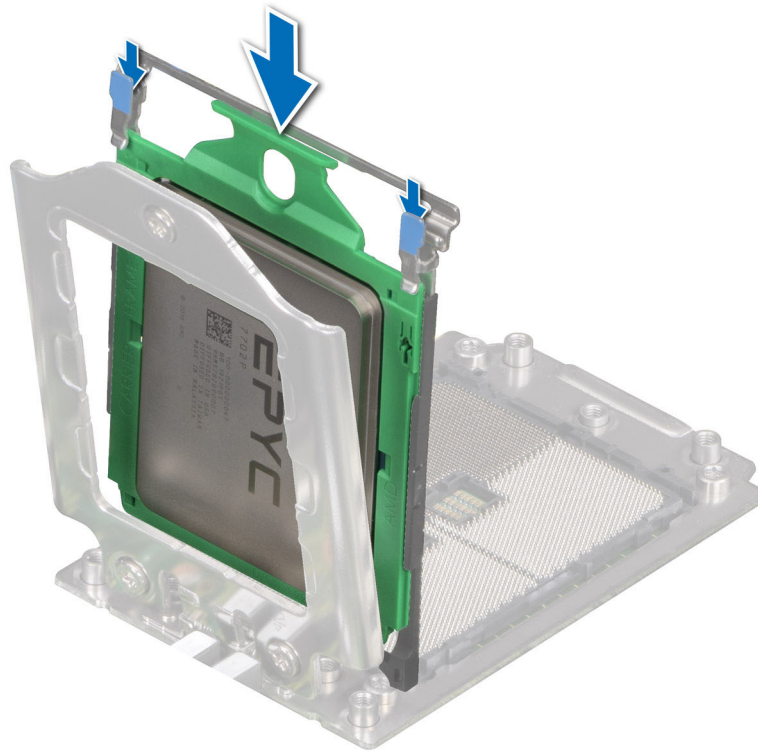

Figure 48. Placing the processor tray into the rail frame

2. Push the rail frame down until the blue latches lock into place.

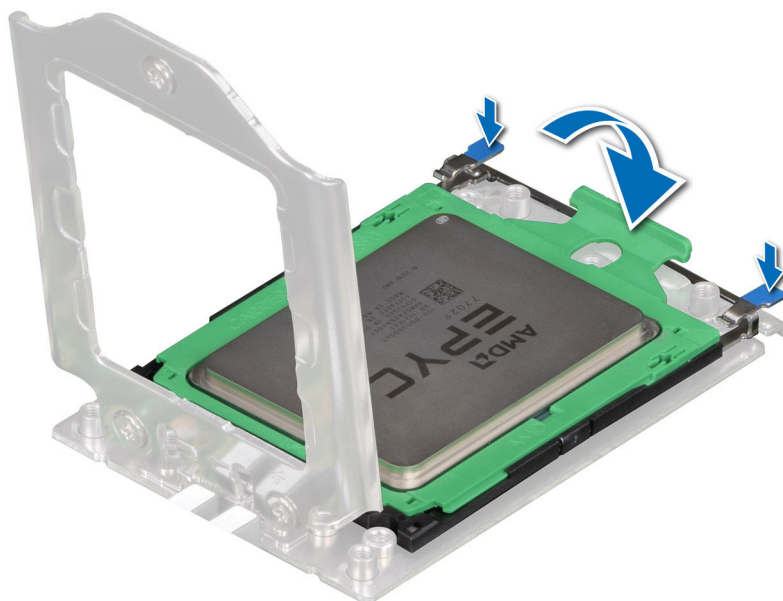

Figure 49. Closing the rail frame

3. Secure the force plate to the processor socket base by tightening the screws in the sequence 1, 2, and 3. When all three screws are fully threaded, the socket is then actuated. The three screws are tightened to a torque value of 12.0 ± 1.0 lbf-in.

NOTE: Press the force plate while tightening the screws to avoid tilting of the processor cover out of the processor socket.

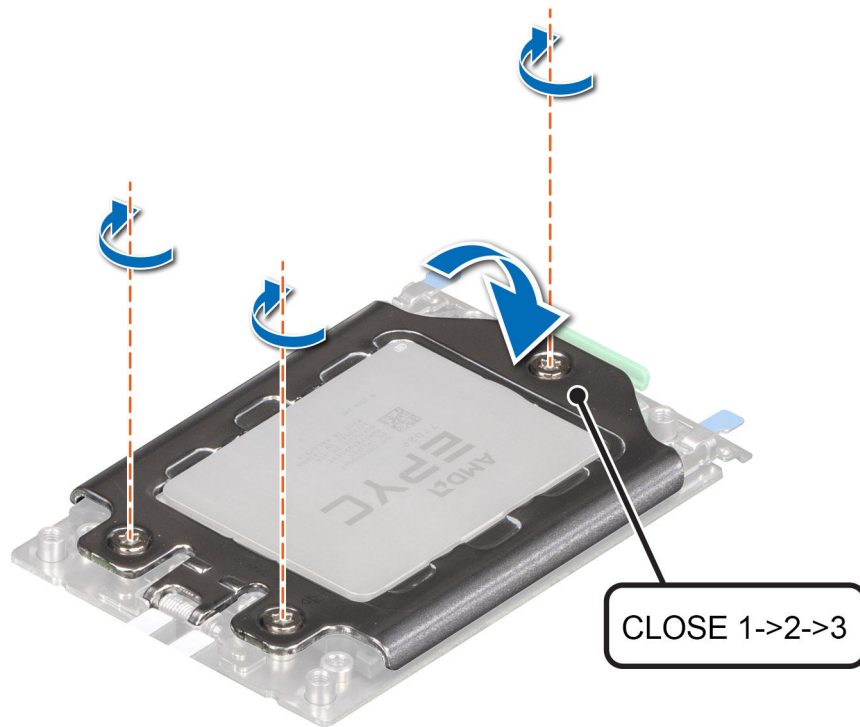

Figure 50. Securing the force plate

Next steps

1. [Install the heat sink.](#)
2. [Install the air shroud.](#)
3. Follow the procedure in [After working inside your system.](#)

Installing the heat sink

Prerequisites

1. Follow the safety guidelines listed in the [Safety instructions.](#)
2. Follow the procedure listed in the [Before working inside your system.](#)
3. [Remove the air shroud.](#)

Steps

1. If you are using an existing heat sink, remove the thermal grease from the heat sink using a clean lint-free cloth.
2. Use the thermal grease syringe included with your processor kit to apply the grease in a thin spiral on the top of the processor.

CAUTION: Applying too much thermal grease can result in excess grease coming in contact with and contaminating the processor socket.

NOTE: The thermal grease syringe is intended for one-time use only. Dispose the syringe after you use it.

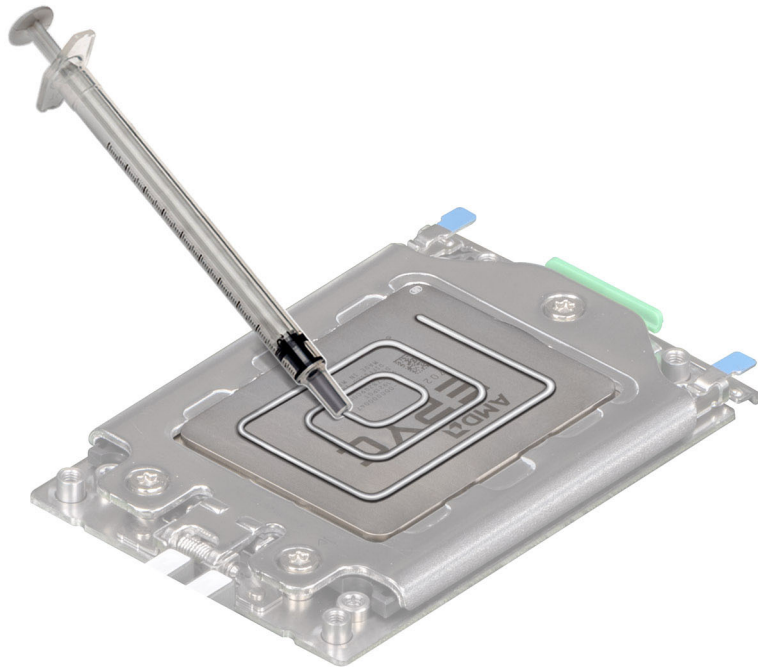

Figure 51. Applying thermal grease on top of the processor

3. Align the screws on the heat sink with the standoff screws on the system board.
4. Using a Torx #T20 screwdriver, tighten the captive screws in the order mentioned below:
 - a. Partially tighten the captive screws 1 and 2 (approximately 3 turns).
 - b. Partially tighten the captive screws 3 and 4 (approximately 3 turns).
 - c. Tighten the captive screws 1 and 2 completely.
 - d. Tighten the captive screws 3 and 4 completely.

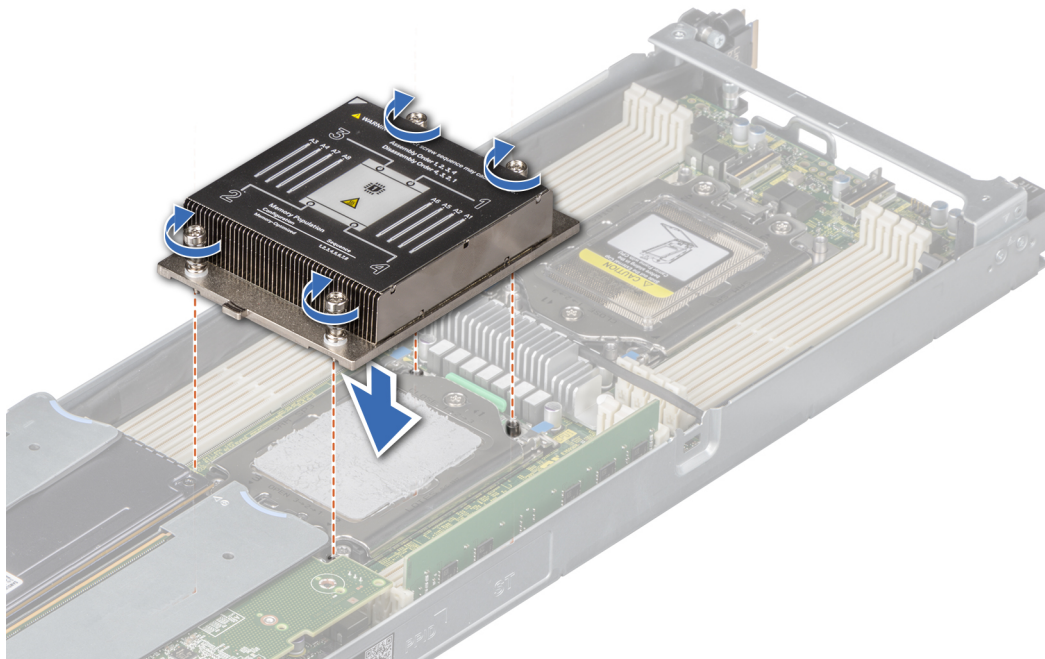

Figure 52. Installing the heat sink

5. Return to the first screw to tighten it.

Next steps

1. [Install the air shroud.](#)
2. Follow the procedure listed in the [After working inside your system.](#)

Liquid cooling heat sink with liquid leak sensor

Removing the liquid cooling heat sink with liquid leak sensor cover

Prerequisites

1. Follow the safety guidelines listed in the [Safety instructions.](#)
2. Follow the procedure listed in the [Before working inside your system.](#)
3. If applicable, [remove the air shroud.](#)
4. If applicable, [remove the standard heat sink.](#)

NOTE: The heat sink and processor are too hot to touch for some time after the system has been powered down. Allow the heat sink and processor to cool down before handling them.

Steps

1. Using a Phillips #1 screw driver, remove the screws that secure the liquid cooling heat sink with liquid leak sensor cover.

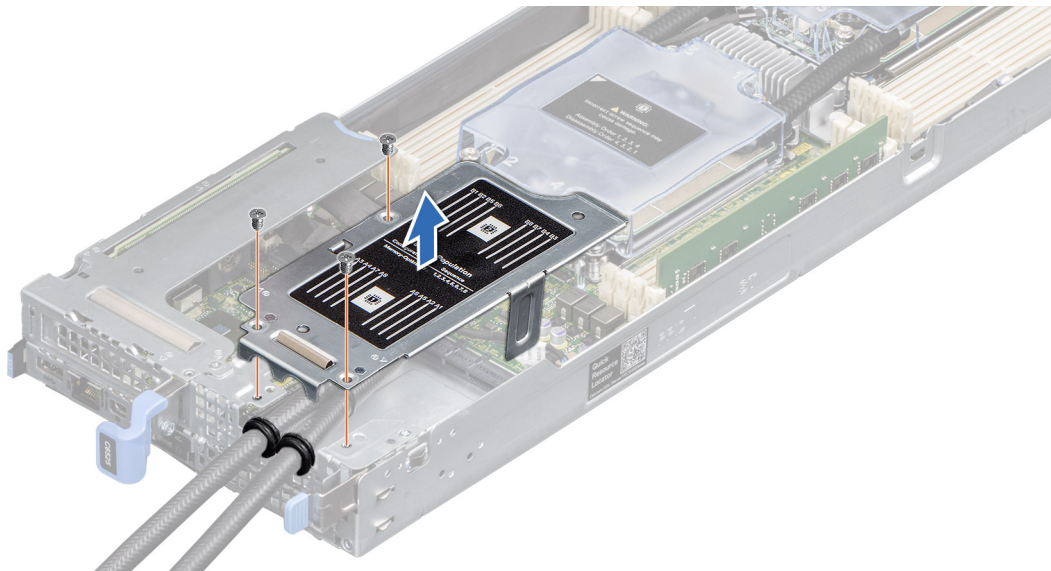

Figure 53. Removing the liquid cooling heat sink with liquid leak sensor cover

2. Remove the liquid cooling heat sink with liquid leak sensor cover.

NOTE: If applicable, route and engage the liquid cooling heat sink with liquid leak sensor tubes with the groves in the liquid cooling heat sink bracket.

Next steps

1. If you are removing a faulty liquid cooling heat sink with liquid leak sensor, [replace the liquid cooling heat sink with liquid leak sensor](#), if not, [remove the processor.](#)
2. If you are replacing the liquid cooling heat sink with a standard heat sink [replace the heat sink](#), if not, [remove the processor.](#)
3. If applicable, [replace the air shroud.](#)

Removing the liquid cooling heat sink with liquid leak sensor

Prerequisites

1. Follow the safety guidelines listed in the [Safety instructions](#).
2. Follow the procedure listed in the [Before working inside your system](#).
3. [Remove the liquid cooling heat sink with liquid leak sensor cover](#).

NOTE: The heat sink and processor are too hot to touch for some time after the system has been powered down. Allow the heat sink and processor to cool down before handling them.

Steps

1. Disconnect the liquid leak sensor cable from the system board.
2. Disengage the liquid cooling heat sink with liquid leak sensor tubes from the grooves in the liquid cooling heat sink bracket.
3. Using a Torx #T20 screwdriver, loosen the captive screws in the order mentioned below. Lift the liquid cooling heat sink with liquid leak sensor from the system.
 - a. Partially loosen the captive screws 4 and 3 (approximately 3 turns).
 - b. Partially loosen the captive screws 2 and 1 (approximately 3 turns).
 - c. Loosen the captive screws 4 and 3 completely.
 - d. Loosen the captive screws 2 and 1 completely.

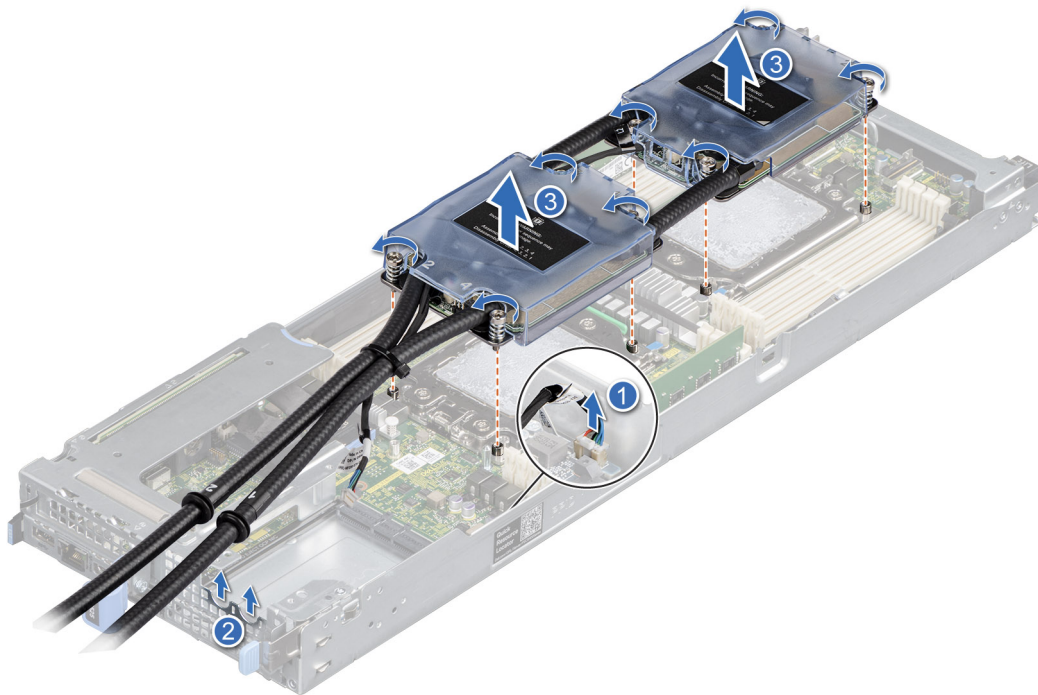

Figure 54. Removing the liquid cooling heat sink with liquid leak sensor

Next steps

1. If you are removing a faulty liquid cooling heat sink, [replace the liquid cooling heat sink with liquid leak sensor](#), if not, [remove the processor](#).
2. If you are replacing the liquid cooling heat sink with a standard heat sink [replace the heat sink](#), if not, [remove the processor](#).
3. [Replace the liquid cooling heat sink with liquid leak sensor cover](#).
4. [Replace the air shroud](#).

Installing the liquid cooling heat sink with liquid leak sensor

Prerequisites

1. Follow the safety guidelines listed in the [Safety instructions](#).
2. Follow the procedure listed in the [Before working inside your system](#).
3. [Remove the air shroud](#).
4. If applicable, [remove the heat sink](#).
5. [Remove the liquid cooling heat sink with liquid leak sensor cover](#).

Steps

1. If you are using an existing heat sink, remove the thermal grease from the liquid cooling heat sink with liquid leak sensor using a clean lint-free cloth.
2. Use the thermal grease syringe included with your processor kit to apply the grease in a thin spiral on the top of the processor.

CAUTION: Applying too much thermal grease can result in excess grease coming in contact with and contaminating the processor socket.

NOTE: The thermal grease syringe is intended for one-time use only. Dispose the syringe after you use it.

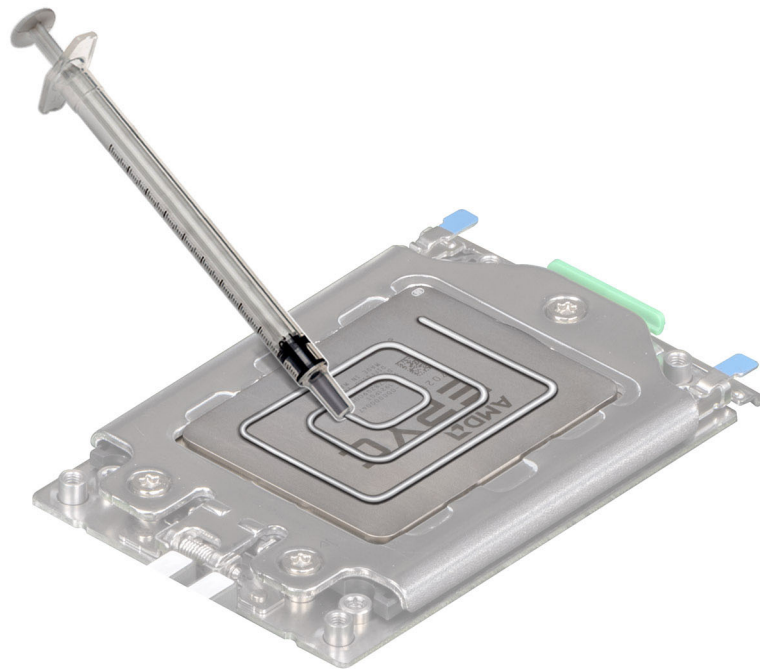

Figure 55. Applying thermal grease on top of the processor

3. Align the screws on the liquid cooling heat sink with liquid leak sensor using the standoff screws on the system board.
4. Using a Torx #T20 screwdriver, tighten the captive screws in the order that is mentioned below:
 - a. Partially tighten the captive screws 1 and 2 (approximately three turns).
 - b. Partially tighten the captive screws 3 and 4 (approximately three turns).
 - c. Tighten the captive screws 1 and 2 completely.
 - d. Tighten the captive screws 3 and 4 completely.

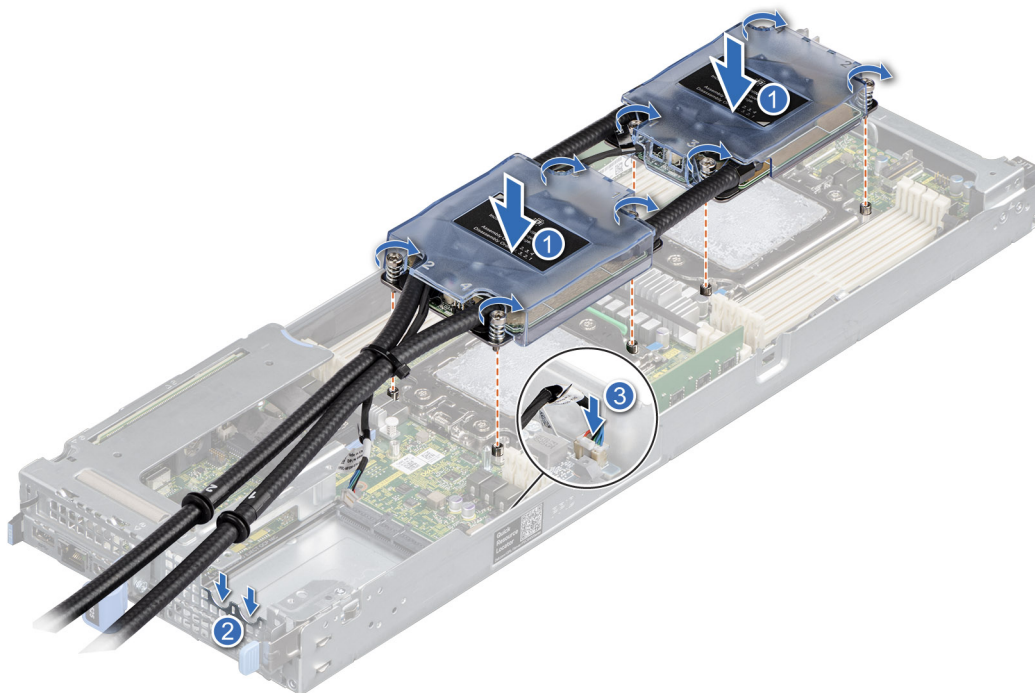

Figure 56. Installing the liquid cooling heat sink with liquid leak sensor

5. Return to the first screw to tighten it.
6. Engage the liquid cooling heat sink with liquid leak sensor tubes on the grooves of the liquid cooling heat sink bracket until it is secured in place.
7. Connect the liquid leak sensor cable on the system board.

i **NOTE:** Liquid leak sensor cable must be connected to the system board, or the entire sensor mechanism does not work.

Next steps

1. [Replace the liquid cooling heat sink with liquid leak sensor cover.](#)
2. Follow the procedure listed in the [After working inside your system.](#)

Installing the liquid cooling heat sink cover

Prerequisites

1. Follow the safety guidelines listed in the [Safety instructions.](#)
2. Follow the procedure listed in the [Before working inside your system.](#)
3. If applicable, [remove the air shroud.](#)
4. If applicable, [remove the heat sink.](#)

Steps

Using a Phillips #1 screw driver, tighten the screws that secure the liquid cooling heat sink cover.

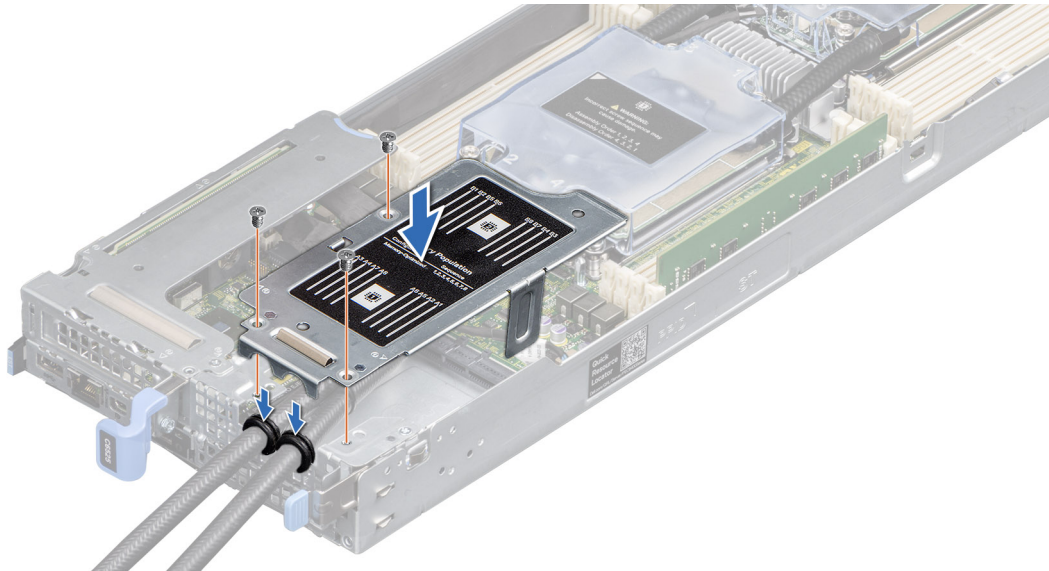

Figure 57. Installing the liquid cooling heat sink cover

NOTE: If applicable, route and engage the liquid cooling heat sink tubes with the groves in the liquid cooling heat sink bracket.

Next steps

1. If you are removing a faulty liquid cooling heat sink, [replace the liquid cooling heat sink with liquid leak sensor](#), if not, [remove the processor](#).
2. If you are replacing the liquid cooling heat sink with a standard heat sink [replace the heat sink](#), if not, [remove the processor](#).
3. If applicable, [replace the air shroud](#).
4. Follow the procedure listed in the [After working inside your system](#).

OCP cards

Removing the OCP filler

Prerequisites

1. Follow the safety guidelines listed in [Safety instructions](#).
2. [Remove the expansion card riser 1](#).
3. [Remove the expansion card riser 2](#).

Steps

Hold and lift the OCP filler from the OCP slot on the chassis.

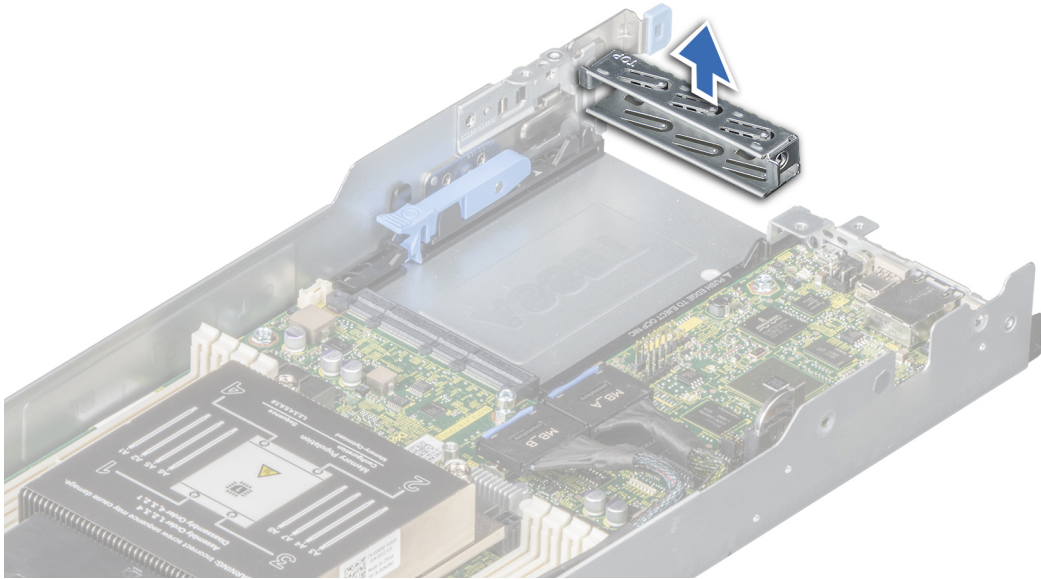

Figure 58. Removing the OCP card filler

Next steps

1. Install the OCP card.
2. Install the expansion card riser 2.
3. Install the expansion card riser 1.

Installing an OCP card

Prerequisites

i **NOTE:** The procedure to install the OCP blank is similar to the removal of a OCP card.

1. Follow the safety guidelines listed in [Safety instructions](#).
2. Remove the expansion card riser 1.
3. Remove the expansion card riser 2.
4. Remove the OCP filler.

Steps

1. Slide the OCP card and push until it is firmly connected to the system board connector.

i **NOTE:** Ensure to lift the OCP card retention latch if it is in the lock position.

2. Press the OCP card retention latch to secure the card in place.

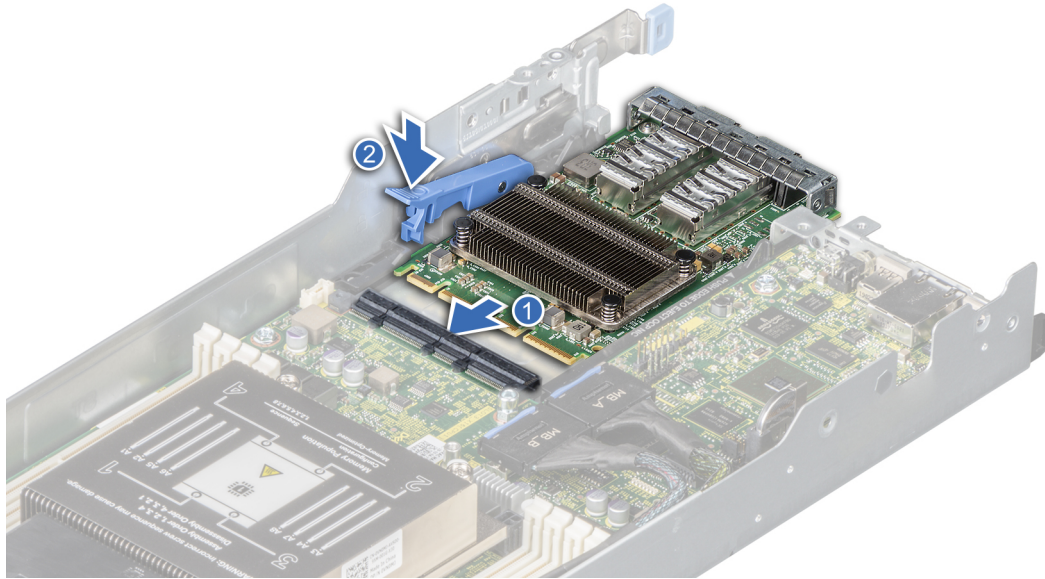

Figure 59. Installing an OCP card

Next steps

1. Install the expansion card riser 2.
2. Install the expansion card riser 1.
3. Follow the procedure listed in [After working inside your system](#).

Removing an OCP card

Prerequisites

1. Follow the safety guidelines listed in [Safety instructions](#).
2. Follow the procedure listed in [Before working inside your system](#).
3. [Remove the expansion card riser 1](#).
4. [Remove the expansion card riser 2](#).

Steps

1. Lift the OCP card retention latch.
2. Pull the OCP card and remove it from the sled.

i NOTE: Install an expansion card filler bracket over an empty expansion slot to maintain Federal Communications Commission (FCC) certification of the system. The brackets also keep dust and dirt out of the system and aid in proper cooling and airflow inside the system.

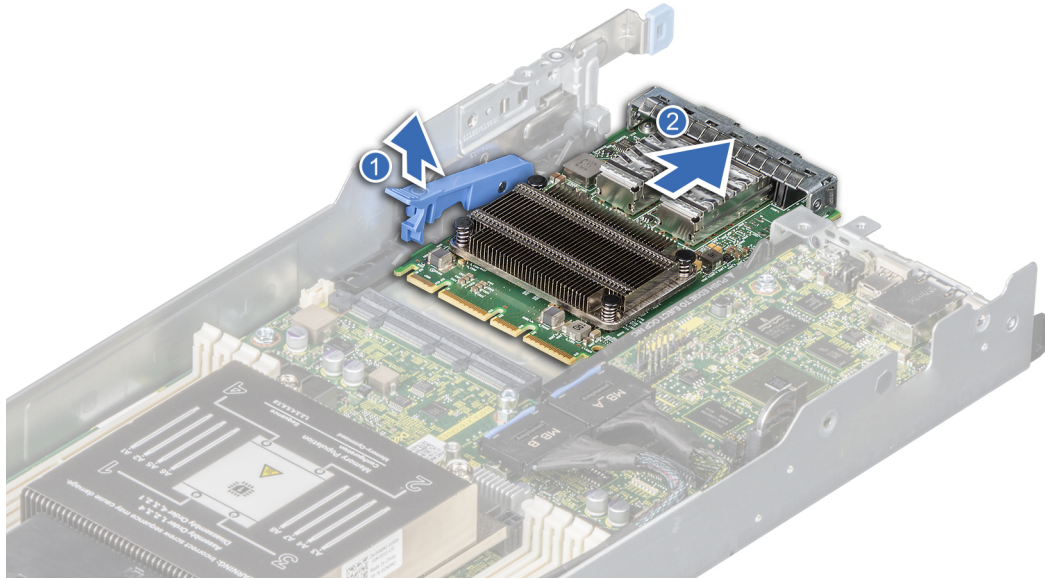

Figure 60. Removing an OCP card

3. Press the OCP card retention latch to lock it.

Next steps

1. [Install the OCP filler.](#)
2. [Install the expansion riser 2.](#)
3. [Install the expansion card riser 1.](#)

Installing the OCP card filler

Prerequisites

1. Follow the safety guidelines listed in [Safety instructions](#).
2. Follow the procedure listed in [Before working inside your system](#).
3. [Remove the expansion card riser 1.](#)
4. [Remove the expansion card riser 2.](#)

Steps

Align and insert the OCP filler until it is firmly seated.

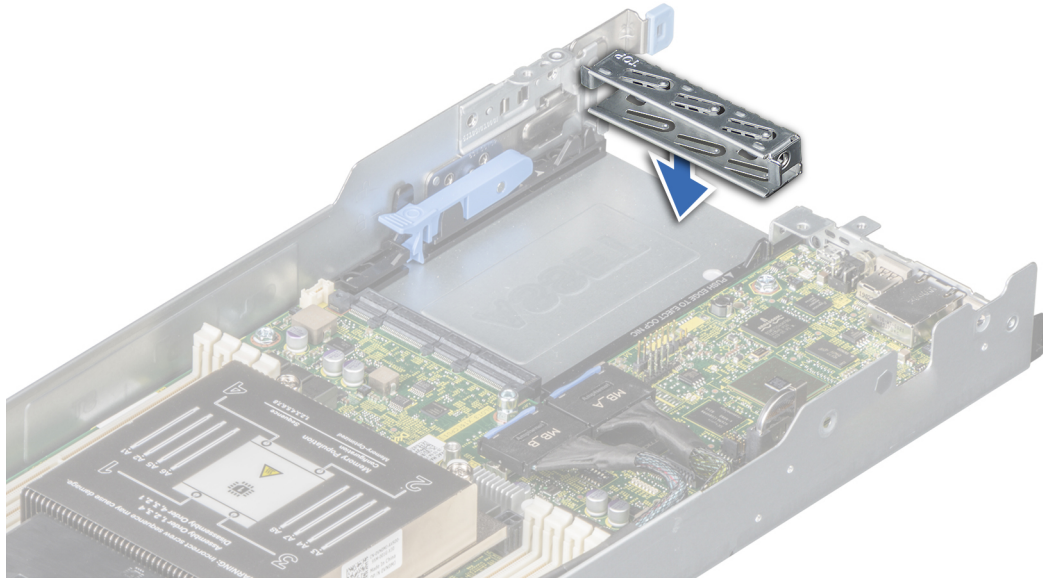

Figure 61. Installing the OCP card filler

Next steps

1. Install the expansion riser 2.
2. Install the expansion card riser 1.

System battery

Replacing system battery

Prerequisites

⚠ WARNING: There is a danger of a new battery exploding if it is incorrectly installed. Replace the battery only with the same or equivalent type that is recommended by the manufacturer. For more information, see the safety information that shipped with your system.

1. Follow the safety guidelines listed in [Safety instructions](#).
2. Follow the procedure listed in [Before working inside your system](#).
3. [Remove the expansion card riser 1](#).

i NOTE: Locate the battery socket. For more information, see the [System board connectors](#) section.

Steps

1. Push the battery holder clip away from the battery.

⚠ CAUTION: To avoid damage to the battery holder clip, ensure that you do not bend the battery holder clip while installing or removing a battery.

2. Pull the battery out of the battery holder.

i NOTE: Ensure that the + side of the battery is facing the battery holder clip.

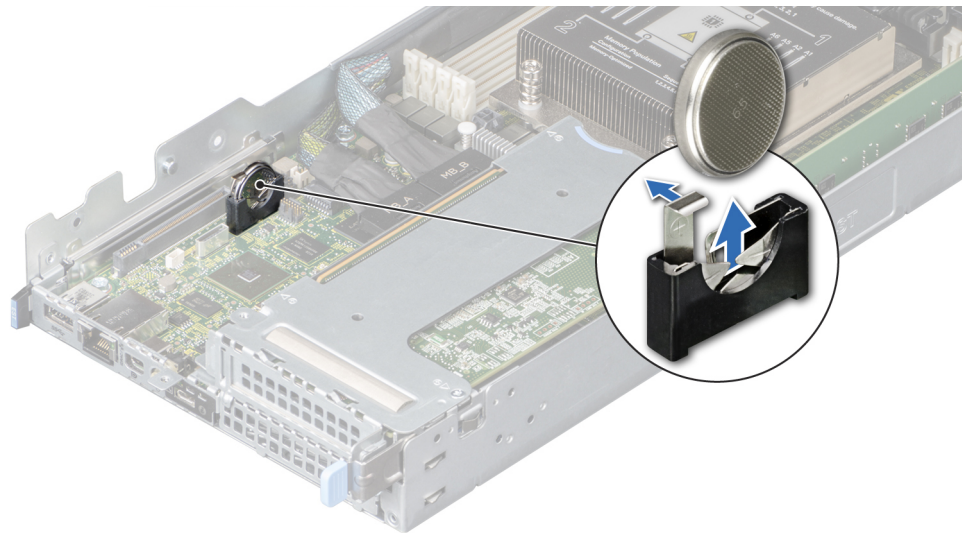

Figure 62. Removing the system battery

3. To install a system battery, push the battery holder clip away.
4. Insert the battery in the battery holder until the battery holder clip snaps into place.

CAUTION: To avoid damage to the battery holder clip, ensure that you do not bend the battery holder clip while installing or removing a battery.

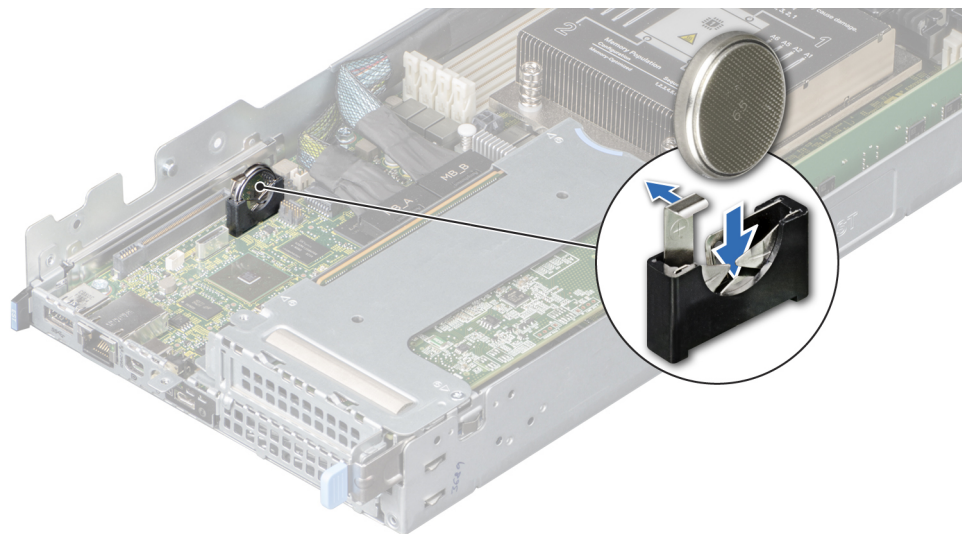

Figure 63. Installing the system battery

Next steps

1. Follow the procedure listed in [After working inside your system](#).
2. Confirm that the battery is operating properly, by performing the following steps:
 - a. Enter the System Setup, while booting, by pressing **F2**.
 - b. Enter the correct time and date in the System Setup **Time** and **Date** fields.
 - c. **Exit** the System Setup.
 - d. To test the newly installed battery, remove the system from the enclosure for at least an hour.
 - e. Reinstall the system into the enclosure after an hour.
 - f. Enter the System Setup and if the time and date are still incorrect, see [Getting help](#) section.

System board

Removing the system board

Prerequisites

- CAUTION:** Do not attempt to remove the TPM plug-in module from the system board. Once the TPM plug-in module is installed, it is cryptographically bound to that specific system board. Any attempt to remove an installed TPM plug-in module breaks the cryptographic binding, and it cannot be reinstalled or installed on another system board.
- CAUTION:** To avoid damage to the system board, ensure that the system board does not touch the side walls of the sled chassis, while sliding the system board into the sled.

1. Follow the safety guidelines listed in [Safety instructions](#).
2. Follow the procedure listed in [Before working inside your system](#).
3. [Remove the sled](#) from the chassis.
4. [Remove the air shroud](#).
5. [Remove the expansion card risers](#).
6. [Remove the heat sink module](#).
7. [Remove the processor](#).
8. [Remove the memory modules](#).
9. If installed, [remove the OCP card](#).
10. [Remove the linking board](#)
11. Disconnect all the cables from the system board.
12. Keep the Phillips #1 screwdriver and #4 nut driver ready.

Steps

1. Using a Phillips #1 screw driver, remove the screws that secure the system board to the chassis.
2. Using a 5mm hex nut driver, remove the standoff screws that secure the system board to the chassis.

- CAUTION:** Do not lift the system board by holding a memory module slot, any other connector, or component.

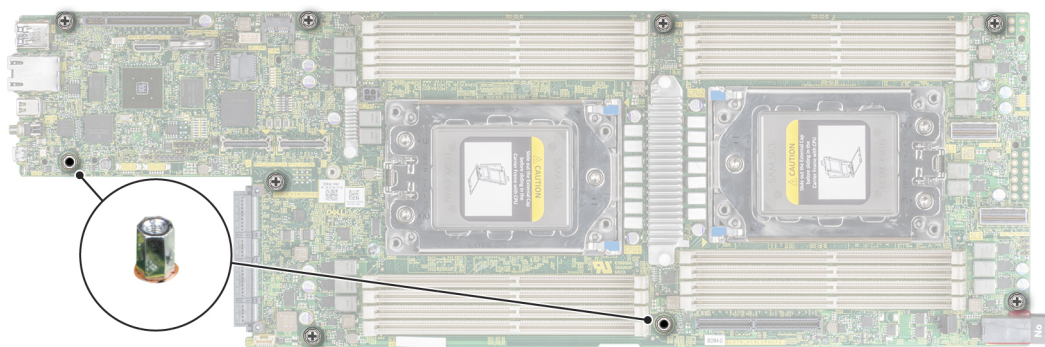

Figure 64. System board screws

3. To disengage the ports from the slots on the chassis, push the system board to the front of the chassis.
4. Hold the system board by the edges and lift it at an angle and remove it from the chassis.

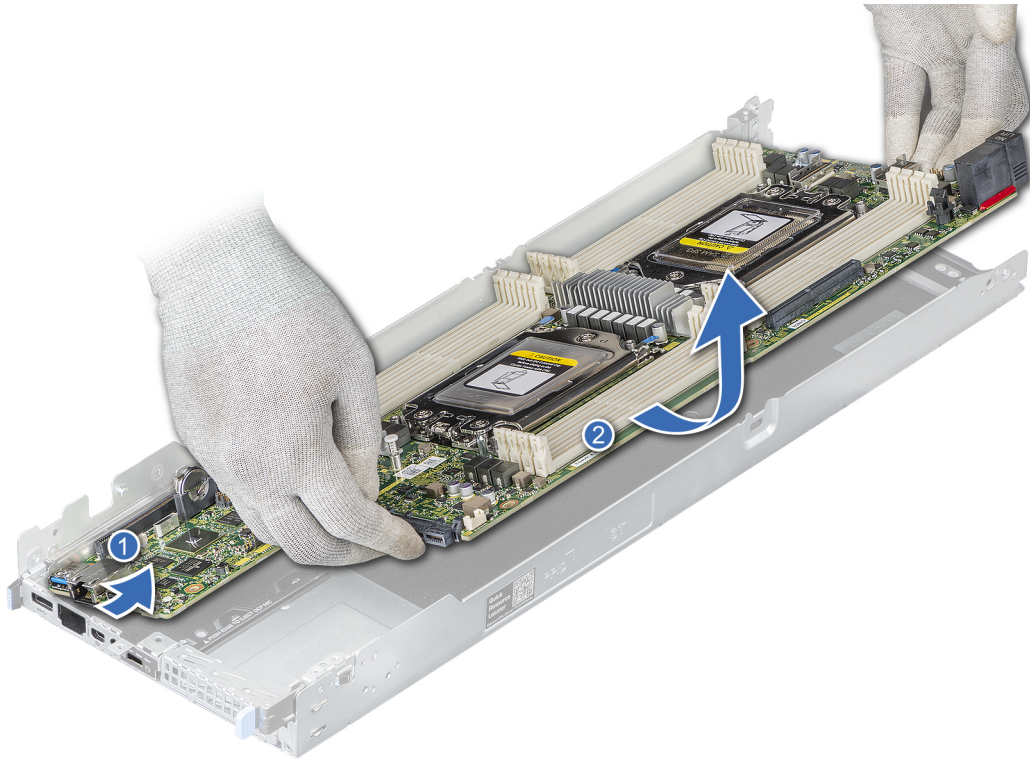

Figure 65. Removing the system board

Next steps

1. [Install the system board.](#)

Installing the system board

Prerequisites

1. Follow the safety guidelines listed in [Safety instructions](#).
2. Follow the procedure listed in [Before working inside your system](#).

CAUTION: To avoid damage to the system board, ensure that the system board does not touch the side walls of the sled chassis, while sliding the system board into the sled.

Steps

1. Holding the system board by the edges and insert it at an angle and install it into the chassis.
2. To engage the ports with the slots on the chassis, push the system board to the rear of the chassis.

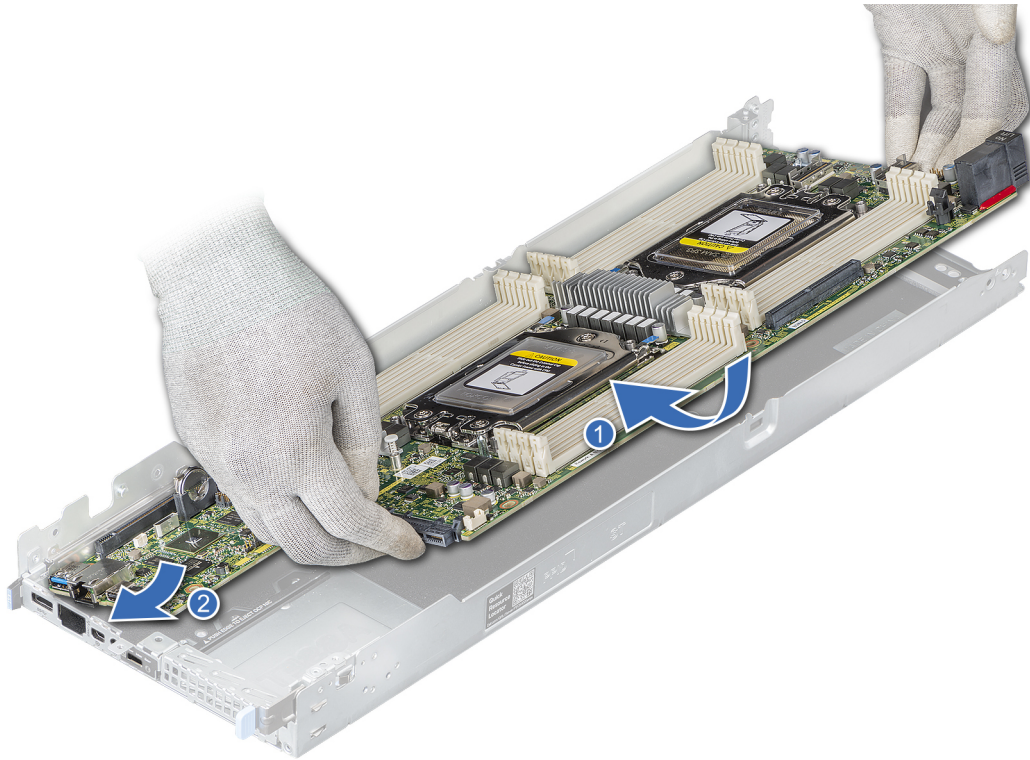

Figure 66. Installing the system board

3. Using a 5mm hex nut driver, secure the standoff screws that secure the system board to the chassis.
4. Using a Phillips #1 screw driver, secure the screws that secure the system board to the chassis.

Next steps



1. If not installed, install the Trusted Platform Module (TPM). For information about how to install the TPM, see the Installing the Trusted Platform Module section. For more information about the TPM, see the Trusted Platform Module section.
 - i** **NOTE:** The TPM plug-in module that is once installed is attached to the system board and cannot be removed. In the event of a system board replacement, a TPM plug-in module is provided along with the system board for all systems that have a TPM.
2. Replace the following components:
 - a. Air shroud
 - b. Expansion card risers
 - c. Heat sink module
 - d. Processor
 - e. Memory modules
 - f. OCP card
 - g. Linking board
3. Reconnect all cables to the system board.
 - i** **NOTE:** Ensure that the cables inside the system are routed along the chassis wall and secured using the cable securing bracket.
4. Follow the procedure that is listed in After working inside your system.
5. Ensure that you:
 - a. Use the Easy Restore feature to restore the Service Tag. For more information, see the Restoring the system using Easy Restore section.
 - b. If the Service Tag is not backed up in the backup flash device, enter the Service Tag manually. For more information, see the Restoring the system using Easy Restore section.
 - c. Update the BIOS and iDRAC versions.
 - d. Re-enable the Trusted Platform Module (TPM). For more information, see the Upgrading the Trusted Platform Module section.
6. Import your new or existing iDRAC Enterprise license. For more information, see iDRAC User's Guide, at [idrac manuals](#).

Restoring the system using Easy Restore

The easy restore feature enables you to restore your service tag, license, UEFI configuration, and the system configuration data after replacing the system board. All data is backed up in a backup flash device automatically. If BIOS detects a new system board, and the service tag in the backup flash device, BIOS prompts the user to restore the backup information.

About this task

Below is a list of options available:

- Restore the service tag, license, and diagnostics information, press **Y**
 - Navigate to the Lifecycle Controller based restore options, press **N**.
 - Restore data from a previously created **Hardware Server Profile**, press **F10**
-  **NOTE:** When the restore process is complete, BIOS prompts to restore the system configuration data.
- To restore the system configuration data, press **Y**
 - To use the default configuration settings, press **N**
-  **NOTE:** After the restore process is complete, system reboots.

Trusted Platform Module

Upgrading the Trusted Platform Module

Removing the TPM

Prerequisites

-  **NOTE:**
- Ensure that your operating system supports the version of the TPM module being installed.
 - Ensure that you download and install the latest BIOS firmware on your system.
 - Ensure that the BIOS is configured to enable UEFI boot mode.

About this task

 **CAUTION:** Once the TPM plug-in module is installed, it is cryptographically bound to that specific system board. Any attempt to remove an installed TPM plug-in module breaks the cryptographic binding, the removed TPM cannot be reinstalled or installed on another system board.

Steps

1. Locate the TPM connector on the system board.
2. Press to hold the module down and remove the screw using the security Torx 8-bit shipped with the TPM module.
3. Slide the TPM module out from its connector.
4. Push the plastic rivet away from the TPM connector and rotate it 90° counterclockwise to release it from the system board.
5. Pull the plastic rivet out of its slot on the system board.

Installing the TPM

Steps

1. To install the TPM, align the edge connectors on the TPM with the slot on the TPM connector.
2. Insert the TPM into the TPM connector such that the plastic rivet aligns with the slot on the system board.
3. Press the plastic rivet until the rivet snaps into place.
4. Replace the screw that secures the TPM to the system board.

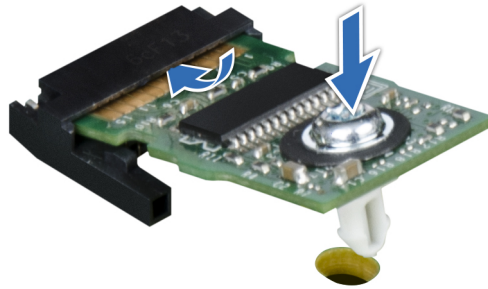

Figure 67. Installing the TPM

Initializing TPM for users

Steps

1. Initialize the TPM.
For more information, see [Initializing the TPM for users](#).
2. The **TPM Status** changes to **Enabled, Activated**.

Initializing the TPM 1.2 for users

Steps

1. While booting your system, press F2 to enter System Setup.
2. On the **System Setup Main Menu** screen, click **System BIOS > System Security Settings**.
3. From the **TPM Security** option, select **On with Preboot Measurements**.
4. From the **TPM Command** option, select **Activate**.
5. Save the settings.
6. Restart your system.

Initializing the TPM 2.0 for users

Steps

1. While booting your system, press F2 to enter System Setup.
2. On the **System Setup Main Menu** screen, click **System BIOS > System Security Settings**.
3. From the **TPM Security** option, select **On**.
4. Save the settings.
5. Restart your system.

Jumpers and connectors

This section provides essential and specific information about jumpers and switches. It also describes the connectors on the various boards in the system. Jumpers on the system board help to disable the system and reset the passwords. To install components and cables correctly, you must be able to identify the connectors on the system board.

Topics:

- System board connectors
- System board jumper settings
- Disabling a forgotten password

System board connectors

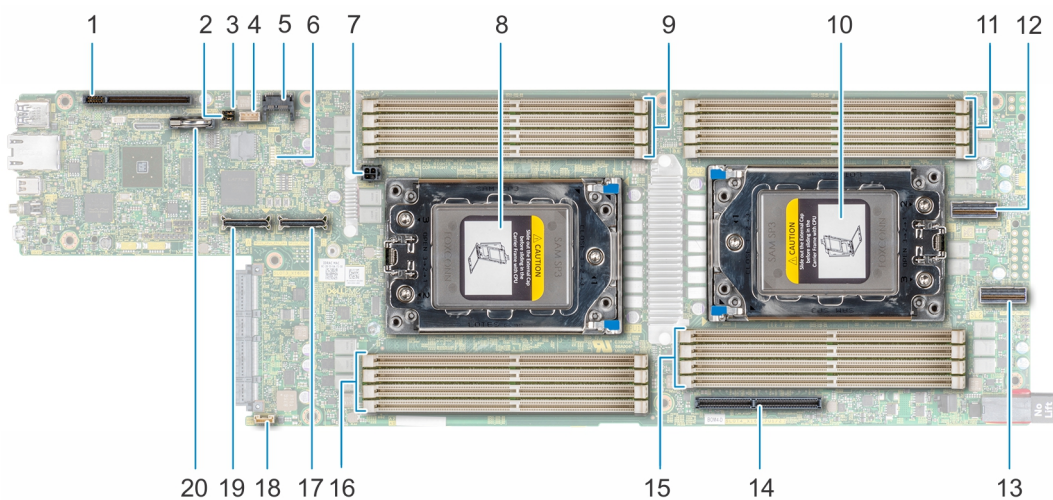

Figure 68. System board connectors

Table 17. System board jumpers and connectors

Item	Connector	Description
1.	SLOT1_X16 (CPU1/2)	Riser 1 connector
2.	PWRD_EN	Password clear jumper
3.	NVRAM_CLR	NVRAM clear jumper
4.	INT_USB1	Internal USB connector
5.	TPM	TPM connector
6.	CPLD Diagnostic LED / OmniVu Decoder	System board diagnostic LED indicators
7.	MB_PWR	PCIe Riser 2A Power Connector
8.	CPU1	Processor socket 1
9.	A3, A4, A7, A8	Memory module sockets for CPU 1
10.	CPU2	Processor socket 2





Table 17. System board jumpers and connectors (continued)

Item	Connector	Description
11.	B1, B2, B5, B6	Memory module sockets for CPU 2
12.	SL1_CPU2_PB2	Slimline cable connector 1
13.	SL2_CPU2_PA2_SA2	Slimline cable connector 2
14.	SLOT4_X16 (CPU1/2)	M.2 riser / BOSS card S1V5 connector <i>i</i> NOTE: The M.2 solution for HW RAID BOSS card is Gen3 x8. C6526 slot 4 PCIe lanes are Gen3 x8 from CPU1 + Gen4 x8 from CPU2. This is for Dell internal purpose only.
15.	B3, B4, B7, B8	Memory module sockets for CPU 2
16.	A1, A2, A5, A6	Memory module sockets for CPU 1
17.	NPIO2_CPU1_PB1	NVMe Connector
18.	LEAK_DET	Leak Sensor Connector (Optional)
19.	NPIO_CPU1_PA1_SA1	SATA / NVMe Connector
20.	BATTERY	Coin Cell Battery

System board jumper settings

For information about resetting the password jumper to disable a password, see the [Disabling a forgotten password](#) section.

Table 18. System board jumper settings

Jumper	Setting	Pin number	Description
NVRAM_CLR		2, 3	The BIOS configuration settings are retained at system boot.
		1, 2	The BIOS configuration settings are cleared at system boot.
PWRD_EN		1, 2	The BIOS password feature is enabled.
		2, 3	The BIOS password feature is disabled. iDRAC local access is unlocked at next AC power cycle. iDRAC password reset is enabled in F2 iDRAC settings menu.

CAUTION: Be careful when changing the BIOS settings. The BIOS interface is designed for advanced users. Any change in the setting could prevent your system from starting correctly and you might have potential loss of data.



Disabling a forgotten password

The software security features of the system include a system password and a setup password. The password jumper enables or disables password features and clears any password(s) currently in use.

Prerequisites

 **CAUTION:** Many repairs may only be done by a certified service technician. You should only perform troubleshooting and simple repairs as authorized in your product documentation, or as directed by the online or telephone service and support team. Damage due to servicing that is not authorized by Dell is not covered by your warranty. Read and follow the safety instructions that are shipped with your product.

Steps

1. Power off the system, and all the attached peripherals, and disconnect the system from the electrical outlet.
2. Remove the system cover.
3. Move the jumper on the system board from pins 1 and 2 to pins 2 and 3.
4. Replace the system cover.
 -  **NOTE:** The existing passwords are not disabled (erased) until the system boots with the jumper on pins 2 and 3. However, before you assign a new system and/or setup password, you must move the jumper back to pins 1 and 2.
 -  **NOTE:** If you assign a new system and/or setup password with the jumper on pins 2 and 3, the system disables the new password(s) the next time it boots.
5. Reconnect the system and all the attached peripherals.
6. Power off the system.
7. Remove the system cover.
8. Move the jumper on the system board from pins 2 and 3 to pins 1 and 2.
9. Replace the system cover.
10. Reconnect the system to the electrical outlet and power on the system, and all the attached peripherals.
11. Assign a new system and/or setup password.

System diagnostics

If you experience a problem with your system, run the system diagnostics before contacting Dell for technical assistance. The purpose of running system diagnostics is to test your system hardware without using additional equipment or risking data loss. If you are unable to fix the problem yourself, service and support personnel can use the diagnostics results to help you solve the problem.

Topics:

- [Dell Embedded System Diagnostics](#)

Dell Embedded System Diagnostics

NOTE: The Dell Embedded System Diagnostics is also known as Enhanced Pre-boot System Assessment (ePSA) diagnostics.

The Embedded System Diagnostics provides a set of options for particular device groups or devices allowing you to:

- Run tests automatically or in an interactive mode
- Repeat tests
- Display or save test results
- Run thorough tests to introduce additional test options to provide extra information about the failed device(s)
- View status messages that inform you if tests are completed successfully
- View error messages that inform you of problems encountered during testing

Running the Embedded System Diagnostics from Boot Manager

Run the Embedded System Diagnostics (ePSA) if your system does not boot.

Steps

1. When the system is booting, press F11.
2. Use the up arrow and down arrow keys to select **System Utilities > Launch Diagnostics**.
3. Alternatively, when the system is booting, press F10, select **Hardware Diagnostics > Run Hardware Diagnostics**. The **ePSA Pre-boot System Assessment** window is displayed, listing all devices detected in the system. The diagnostics starts executing the tests on all the detected devices.

Running the Embedded System Diagnostics from the Dell Lifecycle Controller

Steps

1. As the system boots, press F10.
2. Select **Hardware Diagnostics → Run Hardware Diagnostics**. The **ePSA Pre-boot System Assessment** window is displayed, listing all devices detected in the system. The diagnostics starts executing the tests on all the detected devices.

System diagnostic controls

Menu	Description
Configuration	Displays the configuration and status information of all detected devices.

Menu	Description
Results	Displays the results of all tests that are run.
System health	Provides the current overview of the system performance.
Event log	Displays a time-stamped log of the results of all tests run on the system. This is displayed if at least one event description is recorded.

Known Issue

AMD ROME Erratum 1474

Issue:

- A core may hang after about 1044 days due to failure of exiting CC6 after about 1044 days after the last system reset. The time of failure may vary depending on the spread spectrum and REFCLK frequency.

Workaround:

- Option 1: Disable CC6 by writing 0x80808 to CSTATE_CONFIG (MSR 0xC001_0296) to all cores or by setting '0' for PcdAMDCStateMode before the projected time of failure.
- Option 2: Reboot the system before the projected time of failure.

Fix planned:

- No fix planned.

Getting help

Topics:

- [Recycling or End-of-Life service information](#)
- [Contacting Dell](#)
- [Accessing system information by using QRL](#)
- [Receiving automated support with SupportAssist](#)

Recycling or End-of-Life service information

Take back and recycling services are offered for this product in certain countries. If you want to dispose of system components, visit the [How to Recycle](#) page and select the relevant country.

Contacting Dell

Dell provides online and telephone based support and service options. If you do not have an active internet connection, you can find Dell contact information on your purchase invoice, packing slip, bill or Dell product catalog. The availability of services varies depending on the country and product, and some services may not be available in your area. To contact Dell for sales, technical assistance, or customer service issues:

Steps

1. Go to the [Support](#) site.
2. Select your country from the drop-down menu on the lower right corner of the page.
3. For customized support:
 - a. Enter the system Service Tag in the **Enter a Service Tag, Serial Number, Service Request, Model, or Keyword** field.
 - b. Click **Submit**.
The support page that lists the various support categories is displayed.
4. For general support:
 - a. Select your product category.
 - b. Select your product segment.
 - c. Select your product.
The support page that lists the various support categories is displayed.
5. For contact details of Dell Global Technical Support:
 - a. Click [Contact Technical Support](#).
 - b. The **Contact Technical Support** page is displayed with details to call, chat, or e-mail the Dell Global Technical Support team.

Accessing system information by using QRL

You can use the Quick Resource Locator (QRL) located on the information tag in the rear of the C6525 system, to access information about Dell Technologies PowerEdge C6525.

Prerequisites

Ensure that your smartphone or tablet has the QR code scanner installed.

The QRL includes the following information about your system:

- How-to videos
- Reference materials, including the Installation and Service Manual, and mechanical overview
- The system service tag to quickly access the specific hardware configuration and warranty information
- A direct link to Dell to contact technical assistance and sales teams

Steps

1. Go to [QRL](#), and navigate to your specific product or
2. Use your smart phone or tablet to scan the model-specific Quick Resource (QR) code on your system or in the Quick Resource Locator section.

Quick Resource Locator for PowerEdge C6525 system

Quick Resource Locator

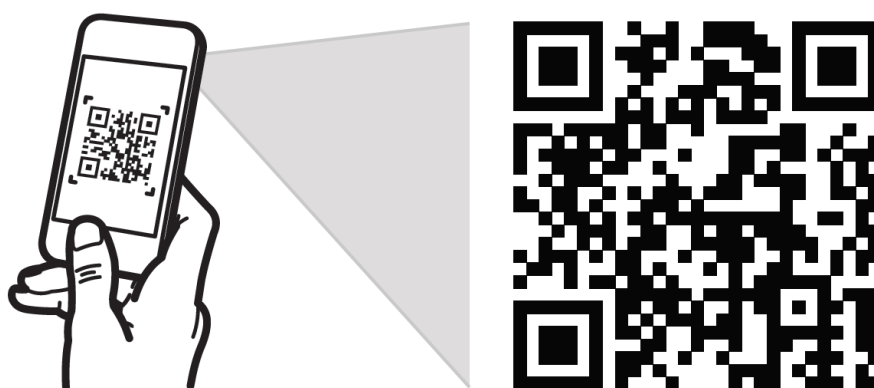

Dell.com/QRL/Server/PEC6525

Figure 69. Quick Resource Locator for PowerEdge C6525 system

Receiving automated support with SupportAssist

Dell SupportAssist is an optional Dell Services offering that automates technical support for your Dell server, storage, and networking devices. By installing and setting up a SupportAssist application in your IT environment, you can receive the following benefits:

- Automated issue detection — SupportAssist monitors your Dell devices and automatically detects hardware issues, both proactively and predictively.
- Automated case creation — When an issue is detected, SupportAssist automatically opens a support case with Dell Technical Support.
- Automated diagnostic collection — SupportAssist automatically collects system state information from your devices and uploads it securely to Dell. This information is used by Dell Technical Support to troubleshoot the issue.
- Proactive contact — A Dell Technical Support agent contacts you about the support case and helps you resolve the issue.

The available benefits vary depending on the Dell Service entitlement purchased for your device. For more information about SupportAssist, go to the [SupportAssist](#) page.

Documentation resources

This section provides information about the documentation resources for your system.

To view the document that is listed in the documentation resources table:

- From the Dell support site:
 1. Click the documentation link that is provided in the Location column in the table.
 2. Click the required product or product version.
-  **NOTE:** To locate the product name and model, see the front of your system.
- On the Product Support page, click **Manuals & documents**.
- Using search engines:
 - Type the name and version of the document in the search box.

Table 19. Additional documentation resources for your system

Task	Document	Location
Setting up your system	<p>For more information about installing and securing the system into a rack, see the Rail Installation Guide included with your rail solution.</p> <p>For information about setting up your system, see the <i>Getting Started Guide</i> document that is shipped with your system.</p>	PowerEdge manuals
Configuring your system	<p>For information about the iDRAC features, configuring and logging in to iDRAC, and managing your system remotely, see the Integrated Dell Remote Access Controller User's Guide.</p> <p>For information about understanding Remote Access Controller Admin (RACADM) subcommands and supported RACADM interfaces, see the RACADM CLI Guide for iDRAC.</p> <p>For information about Redfish and its protocol, supported schema, and Redfish Eventing implemented in iDRAC, see the Redfish API Guide.</p> <p>For information about iDRAC property database group and object descriptions, see the Attribute Registry Guide.</p> <p>For information about Intel QuickAssist Technology, see the Integrated Dell Remote Access Controller User's Guide.</p>	PowerEdge manuals
	<p>For information about earlier versions of the iDRAC documents.</p> <p>To identify the version of iDRAC available on your system, on the iDRAC web interface, click ? > About.</p>	idrac manuals

Table 19. Additional documentation resources for your system (continued)

Task	Document	Location
	For information about updating drivers and firmware, see the Methods to download firmware and drivers section in this document.	Drivers
Managing your system	For information about systems management software offered by Dell, see the Dell OpenManage Systems Management Overview Guide.	PowerEdge manuals
	For information about setting up, using, and troubleshooting OpenManage, see the Dell OpenManage Server Administrator User's Guide.	OpenManage Manuals > OpenManage Server Administrator
	For information about installing, using, and troubleshooting Dell OpenManage Enterprise, see the Dell OpenManage Enterprise User's Guide.	OpenManage Manuals
	For information about partner programs enterprise systems management, see the OpenManage Connections Enterprise Systems Management documents.	OpenManage Manuals
Understanding event and error messages	For information about the event and error messages generated by the system firmware and agents that monitor system components, go to QRL > Look Up > Error Code , type the error code, and then click Look it up .	QRL
Troubleshooting your system	For information about identifying and troubleshooting the PowerEdge server issues, see the Server Troubleshooting Guide.	PowerEdge manuals