

Dell PowerEdge R430

Version 1

Owner's Manual

E28S Series

A03

Copyright © 2017 - 10- Dell All rights reserved.

Dell believes the information in this publication is accurate as of its publication date. The information is subject to change without notice.

THE INFORMATION IN THIS PUBLICATION IS PROVIDED "AS-IS." DELL MAKES NO REPRESENTATIONS OR WARRANTIES OF ANY KIND WITH RESPECT TO THE INFORMATION IN THIS PUBLICATION, AND SPECIFICALLY DISCLAIMS IMPLIED WARRANTIES OF MERCHANTABILITY OR FITNESS FOR A PARTICULAR PURPOSE. USE, COPYING, AND DISTRIBUTION OF ANY DELL SOFTWARE DESCRIBED IN THIS PUBLICATION REQUIRES AN APPLICABLE SOFTWARE LICENSE.

Dell Technologies, Dell, EMC, Dell EMC and other trademarks are trademarks of Dell Inc. or its subsidiaries. Other trademarks may be the property of their respective owners. Published in the USA.

Dell EMC
Hopkinton, Massachusetts 01748-9103
1-508-435-1000 In North America 1-866-464-7381
www.DellEMC.com

CONTENTS

	Notes, cautions, and warnings	0
		0
Chapter 1	Dell PowerEdge R430 system overview	9
	Supported configurations for the PowerEdge R430 system.....	10
	Front panel features.....	10
	Front panel features of a 4 x 3.5-inch hard drive system.....	11
	Front panel features of the 4 x 3.5-inch cabled hard drive system.....	13
	Front panel features of the 8 x 2.5 inch hard drives or SSDs system....	15
	Front panel features of the 10 x 2.5-inch hard drives or SSDs system....	17
	LCD panel.....	18
	Back panel features.....	21
	Redundant PSU back panel features	21
	Cabled PSU back panel features	23
	Diagnostic Indicators.....	26
	Diagnostic indicators on the front panel.....	26
	Hard drive indicator codes.....	27
	uSATA SSD indicator codes.....	28
	NIC indicator codes.....	29
	Internal dual SD module indicator codes.....	30
	iDRAC Direct LED indicator codes.....	31
	Indicator codes for redundant power supply unit.....	32
	Non-redundant power supply unit indicator codes.....	34
	Locating Service Tag of your system.....	35
Chapter 2	Documentation resources	37
Chapter 3	Technical specifications	41
	Chassis dimensions.....	42
	Chassis weight.....	42
	Processor specifications.....	43
	PSU specifications.....	43
	System battery specifications.....	43
	Expansion bus specifications.....	43
	Memory specifications.....	44
	Drive specifications.....	44
	Hard drives.....	44
	Optical drive.....	45
	Ports and connectors specifications.....	45
	USB ports.....	45
	NIC ports.....	45
	Serial connector.....	46
	VGA ports.....	46
	Internal Dual SD Module.....	46
	Video specifications.....	46

	Environmental specifications.....	46
	Particulate and gaseous contamination specifications	48
	Expanded operating temperature.....	49
	Expanded operating temperature restrictions.....	50
Chapter 4	Initial system setup and configuration	51
	Setting up your system.....	52
	iDRAC configuration.....	52
	Options to set up iDRAC IP address.....	52
	Options to install the operating system.....	53
	Methods to download firmware and drivers.....	53
Chapter 5	Pre-operating system management applications	55
	Options to manage the pre-operating system applications.....	56
	System Setup.....	56
	Viewing System Setup.....	56
	System Setup details.....	56
	System BIOS.....	57
	iDRAC Settings utility.....	80
	Device Settings.....	81
	Dell Lifecycle Controller.....	81
	Embedded system management.....	81
	Boot Manager.....	81
	Viewing Boot Manager.....	81
	Boot Manager main menu.....	82
	PXE boot.....	82
Chapter 6	Installing and removing system components	83
	Safety instructions.....	84
	Before working inside your system.....	84
	After working inside your system.....	84
	Recommended tools.....	85
	Front bezel (optional).....	85
	Removing the optional front bezel.....	85
	Installing the optional front bezel.....	86
	System cover.....	87
	Removing the system cover.....	87
	Installing the system cover.....	88
	Inside the system.....	89
	Cooling shroud.....	92
	Removing the cooling shroud.....	92
	Installing the cooling shroud.....	93
	System memory.....	94
	General memory module installation guidelines.....	96
	Mode-specific guidelines.....	96
	Sample memory configurations.....	97
	Removing memory modules.....	102
	Installing memory modules.....	103
	Hard drives.....	105
	Removing a 2.5-inch hard drive blank.....	105
	Installing a 2.5-inch hard drive blank.....	106
	Removing a 3.5-inch hard drive blank.....	107
	Installing a 3.5-inch hard drive blank.....	107
	Removing a 3.5-inch cabled hard drive carrier.....	108

- Installing a 3.5-inch cabled hard drive carrier..... 109
- Removing a hot swappable hard drive carrier..... 110
- Installing a hot swappable hard drive carrier..... 111
- Removing a 3.5-inch hot swappable hard drive adapter from a 3.5-inch hot swappable hard drive carrier..... 113
- Installing a 3.5-inch hard drive adapter into a hot swap hard drive carrier..... 114
- Removing a 2.5-inch hard drive from a 3.5-inch hard drive adapter.... 114
- Installing a 2.5-inch hard drive into a 3.5-inch hard drive adapter..... 115
- Removing a hard drive from a hard drive carrier..... 116
- Installing a hard drive into a hard drive carrier..... 117
- Optical drive (optional)..... 118
 - Removing the optional ultra slim optical drive..... 118
 - Installing the optional ultra slim optical drive..... 119
 - Removing the standard optical drive..... 120
 - Installing the standard optical drive..... 121
- Cooling fans..... 123
 - Removing a cooling fan..... 123
 - Installing a cooling fan..... 124
- Internal USB memory key (optional)..... 125
 - Replacing the optional internal USB memory key..... 125
- Expansion cards and expansion card riser..... 127
 - Expansion card installation guidelines..... 127
 - Removing the expansion card riser..... 128
 - Installing the expansion card riser..... 129
 - Removing an expansion card..... 130
 - Installing an expansion card..... 131
- iDRAC port card (optional)..... 132
 - Removing the optional iDRAC port card..... 133
 - Installing the optional iDRAC port card..... 134
- SD vFlash card (optional)..... 136
 - Removing the optional SD vFlash card..... 136
 - Installing an optional SD vFlash card..... 136
- Internal dual SD module (optional)..... 137
 - Removing an internal SD card..... 137
 - Installing an internal SD card..... 138
 - Removing the optional internal dual SD module..... 139
 - Installing the optional internal dual SD module 140
- Integrated storage controller card..... 141
 - Removing the integrated storage controller card..... 142
 - Installing the integrated storage controller card..... 143
- Processors and heat sinks..... 144
 - Removing a heat sink..... 145
 - Removing a processor..... 146
 - Installing a processor..... 148
 - Installing a heat sink..... 151
- Power supply units..... 153
 - Hot spare feature..... 153
 - Removing a redundant power supply unit..... 154
 - Installing a redundant power supply unit..... 155
 - Removing a cabled power supply unit..... 156
 - Installing a cabled power supply unit..... 157
 - Removing the power supply unit blank..... 159
 - Installing the power supply unit blank..... 159
- System battery..... 160
 - Replacing the system battery..... 160

	Hard-drive backplane.....	162
	Removing the hard drive backplane.....	162
	Installing the hard drive backplane.....	169
	Control panel.....	171
	Removing the control panel.....	171
	Installing the control panel.....	173
	Removing the control panel module.....	175
	Installing the control panel module.....	178
	Power interposer board.....	181
	Removing the power interposer board.....	181
	Installing the power interposer board.....	182
	System board.....	183
	Removing the system board.....	183
	Installing the system board.....	185
	Trusted Platform Module.....	188
	Installing the Trusted Platform Module.....	188
	Initializing the TPM for BitLocker users.....	189
	Initializing the TPM for TXT users.....	189
Chapter 7	Using system diagnostics	191
	Dell Embedded System Diagnostics.....	192
	When to use the Embedded System Diagnostics.....	192
	Running the Embedded System Diagnostics from Boot Manager.....	192
	Running the Embedded System Diagnostics from the Dell Lifecycle Controller.....	192
	System diagnostic controls.....	192
Chapter 8	Jumpers and connectors	195
	System board jumper settings.....	196
	System board connectors.....	197
	Disabling a forgotten password.....	199
Chapter 9	Troubleshooting your system	201
	Troubleshooting system startup failure.....	202
	Troubleshooting external connections.....	202
	Troubleshooting the video subsystem.....	202
	Troubleshooting a USB device.....	202
	Troubleshooting a serial I/O device.....	203
	Troubleshooting a NIC.....	203
	Troubleshooting a wet system.....	204
	Troubleshooting a damaged system.....	205
	Troubleshooting the system battery.....	206
	Troubleshooting power supply units.....	206
	Troubleshooting power source problems.....	206
	Power supply unit problems.....	207
	Troubleshooting cooling problems.....	207
	Troubleshooting cooling fans.....	208
	Troubleshooting system memory.....	208
	Troubleshooting an internal USB key.....	209
	Troubleshooting an SD card.....	210
	Troubleshooting an optical drive.....	211
	Troubleshooting a hard drive.....	211
	Troubleshooting a storage controller.....	212
	Troubleshooting expansion cards.....	213

	Troubleshooting processors.....	214
	System messages.....	214
	Warning messages.....	214
	Diagnostic messages.....	214
	Alert messages.....	214
Chapter 10	Getting help	217
	Contacting Dell.....	218
	Documentation feedback.....	218
	Accessing system information by using QRL.....	218
	Quick Resource Locator for the PowerEdge R430 system.....	219

CHAPTER 1

Dell PowerEdge R430 system overview

The Dell PowerEdge R430 systems are 2U rack servers that support up to two Intel Xeon E5-2600 v3 or Xeon E5-2600 v4 processors, up to 12 DIMMs, and ten hard drives or solid state drives (SSDs).

- [Supported configurations for the PowerEdge R430 system](#)..... 10
- [Front panel features](#).....10
- [Back panel features](#).....21
- [Diagnostic Indicators](#)..... 26
- [Locating Service Tag of your system](#)..... 35

Supported configurations for the PowerEdge R430 system

The Dell PowerEdge R430 system supports the following configurations:

Figure 1 Supported configurations for the PowerEdge R430 system

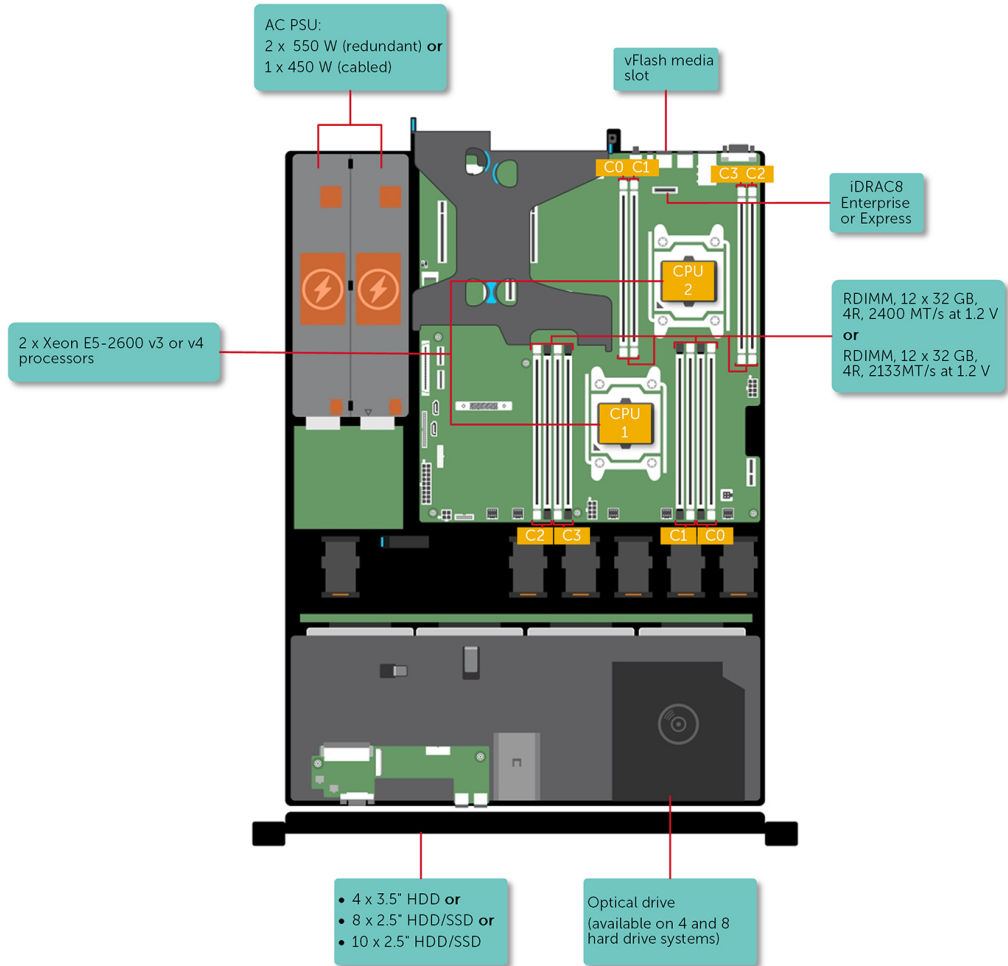

Front panel features

The front panel provides access to the features available on the front of the server, such as the power button, NMI button, system identification tag, system identification button, and USB and

VGA ports. The diagnostic LEDs or the LCD panel is prominently located on the front panel. The hot swappable hard drives are accessible from the front panel.

Front panel features of a 4 x 3.5-inch hard drive system

Figure 2 Front panel features of a 4 x 3.5-inch hard drive system

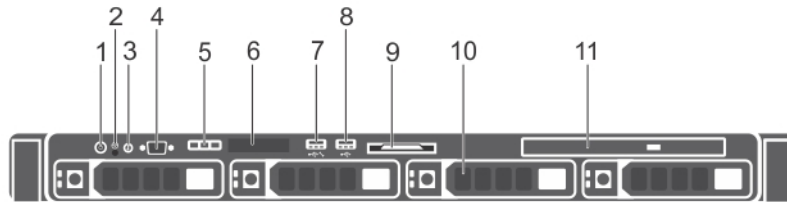

1. Power button
2. NMI button
3. System identification button
4. Video connector
5. LCD menu buttons
6. LCD panel
7. USB management port/iDRAC managed USB port
8. USB port
9. Information tag
10. Hard drives
11. Optical drive (optional)

This table describes about front panel features of a 4 x 3.5-inch hard drive system

Table 1 Front panel features of a 4 x 3.5-inch hard drive system



Item	Indicator, Button, or Connector	Icon	Description
1	Power button		<p>Press the power button to turn the system on or off. The indicator on the button indicates if the system is on or off.</p> <p>Note: To gracefully shut down an ACPI-compliant operating system, press the power button.</p>
2	NMI button		<p>Press the NMI button to troubleshoot software and device driver errors when running certain operating systems. Use the end of a paper clip to press the NMI button.</p> <p>Note: Use the NMI button only if directed to do so by qualified support personnel or by the operating system documentation.</p>

Table 1 Front panel features of a 4 x 3.5-inch hard drive system (continued)





Item	Indicator, Button, or Connector	Icon	Description
3	System identification button		<p>Press the system ID button:</p> <ul style="list-style-type: none"> To locate a particular system within a rack. To turn the system ID on or off. <p>To reset iDRAC, press and hold the button for more than 15 seconds.</p> <p>Note: To reset iDRAC using system ID, ensure that the system ID button is enabled in the iDRAC setup.</p> <p>Note: If the system stops responding during POST, press and hold the system ID button (for more than five seconds) to enter the BIOS progress mode.</p>
4	Video connector		Use the video/VGA port to connect a display to the system. For more information about the supported video/VGA port, see the Technical specifications section.
5	LCD menu buttons		Press the LCD menu buttons to navigate the control panel LCD menu.
6	LCD panel		Displays system ID, status information, and system error messages. For more information, see the LCD panel section.
			Note: LCD panel is not available in a cabled hard drive system.
7	USB management port/iDRAC managed USB port		The USB management port is USB 2.0 compliant. Enables you to connect USB devices to the system or provides access to the iDRAC Direct features. For more information, see the Integrated Dell Remote Access Controller User's Guide at Dell.com/idracmanuals .
8	USB port		Use the USB 2.0 port to connect USB devices to the system. This port is 4-pin, USB 2.0 compliant.
9	Information tag		Displays system information such as service tag, NIC, and MAC address.
			Note: The information tag is a slide-out label panel.
10	Hard drives		Up to four 3.5-inch hard drives or solid state drives (SSD).

Table 1 Front panel features of a 4 x 3.5-inch hard drive system (continued)

Item	Indicator, Button, or Connector	Icon	Description
11	Optical drive (optional)		<p>For information about the supported hard drives, see the Technical specifications section.</p> <p>One optional slim SATA DVD-ROM drive or DVD+/-RW drive.</p> <p>For information about the supported optical drive, see the Technical specifications section.</p>

Front panel features of the 4 x 3.5-inch cabled hard drive system

Figure 3 Front panel features of the 4 x 3.5 inch cabled hard drive system

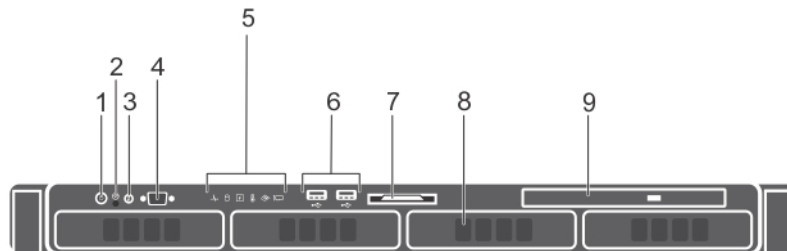

1. Power button
2. NMI button
3. System identification button
4. Video connector
5. Diagnostic indicators
6. USB port (2)
7. Information tag
8. Hard drives
9. Optical drive

Front panel features of the 4 x 3.5 inch cabled hard drive system

Table 2 Front panel features of the 4 x 3.5-inch cabled hard drive system





Item	Indicator, Button, or Connector	Icon	Description
1	Power button		<p>Press the power button to turn the system on or off. The indicator on the button indicates if the system is on or off.</p> <p>Note: To gracefully shut down an ACPI-compliant operating system, press the power button.</p>

Table 2 Front panel features of the 4 x 3.5-inch cabled hard drive system (continued)

Item	Indicator, Button, or Connector	Icon	Description
2	NMI button		<p>Press the NMI button to troubleshoot software and device driver errors when running certain operating systems. Use the end of a paper clip to press the NMI button.</p> <p>Note: Use the NMI button only if directed to do so by qualified support personnel or by the operating system documentation.</p>
3	System identification button		<p>Press the system ID button:</p> <ul style="list-style-type: none"> To locate a particular system within a rack. To turn the system ID on or off. <p>To reset iDRAC, press and hold the button for more than 15 seconds.</p> <p>Note: To reset iDRAC using system ID, ensure that the system ID button is enabled in the iDRAC setup.</p> <p>Note: If the system stops responding during POST, press and hold the system ID button (for more than five seconds) to enter the BIOS progress mode.</p>
4	Video connector		Use the video/VGA port to connect a display to the system. For more information about the supported video/VGA port, see the Technical specifications section.
5	Diagnostic indicators		The diagnostic indicators light up to display error status.
6	USB port (2)		Use the USB 2.0 port to connect USB devices to the system. This port is 4-pin, USB 2.0 compliant.
7	Information tag		<p>Displays system information such as service tag, NIC, and MAC address.</p> <p>Note: The information tag is a slide-out label panel.</p>
8	Hard drives		Up to 4 x 3.5 inch cabled hard drives. For information about the supported hard drives, see the Technical specifications section.
9	Optical drive (optional)		<p>One optional slim SATA DVD-ROM drive or DVD+/-RW drive.</p> <p>For information about the supported optical drive, see the Technical specifications section.</p>

Front panel features of the 8 x 2.5 inch hard drives or SSDs system

Figure 4 Front panel features of a 8 x 2.5 inch hard drives or SSDs system

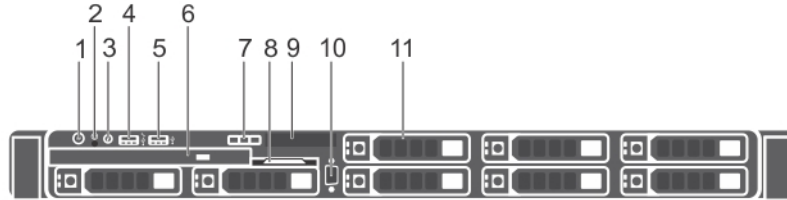

1. Power button
2. NMI button
3. System identification button
4. USB management port or iDRAC managed USB port
5. USB port
6. Optical drive
7. LCD menu buttons
8. Information tag
9. LCD panel
10. Video connector
11. Hard drives

This table describes the front panel features of a 8 x 2.5 inch hard drives or SSDs

Table 3 Front panel features of a 8 x 2.5 inch hard drives or SSDs system



Item	Indicator, Button, or Connector	Icon	Description
1	Power button		<p>Press the power button to turn the system on or off. The indicator on the button indicates if the system is on or off.</p> <p>Note: To gracefully shut down an ACPI-compliant operating system, press the power button.</p>
2	NMI button		<p>Press the NMI button to troubleshoot software and device driver errors when running certain operating systems. Use the end of a paper clip to press the NMI button.</p> <p>Note: Use the NMI button only if directed to do so by qualified support personnel or by the operating system documentation.</p>
3	System identification button		<p>Press the system ID button:</p>

Table 3 Front panel features of a 8 x 2.5 inch hard drives or SSDs system (continued)



Item	Indicator, Button, or Connector	Icon	Description
			<ul style="list-style-type: none"> To locate a particular system within a rack. To turn the system ID on or off. <p>To reset iDRAC, press and hold the button for more than 15 seconds.</p> <p>Note: To reset iDRAC using system ID, ensure that the system ID button is enabled in the iDRAC setup.</p> <p>Note: If the system stops responding during POST, press and hold the system ID button (for more than five seconds) to enter the BIOS progress mode.</p>
4	USB management port or iDRAC managed USB port		The USB management port is USB 2.0 compliant. Enables you to connect USB devices to the system or provides access to the iDRAC Direct features. For more information, see the Integrated Dell Remote Access Controller User's Guide at Dell.com/idracmanuals .
5	USB port		Use the USB 2.0 port to connect USB devices to the system. This port is 4-pin, USB 2.0 compliant.
6	Optical drive (optional)		One optional slim SATA DVD-ROM drive or DVD+/-RW drive.
7	LCD menu buttons		Press the LCD menu buttons to navigate the control panel LCD menu.
8	Information tag		Displays system information such as service tag, NIC, and MAC address.
			Note: The information tag is a slide-out label panel.
9	LCD panel		Displays system ID, status information, and system error messages. For more information, see the LCD panel section.
			Note: LCD panel is not available in a cabled hard drive system.
10	Video connector		Use the video/VGA port to connect a display to the system. For more information about the supported video/VGA port, see the Technical specifications section.
11	Hard drives		Up to 8 x 2.5-inch hard drives or SSDs.

Table 3 Front panel features of a 8 x 2.5 inch hard drives or SSDs system (continued)

Item	Indicator, Button, or Connector	Icon	Description
			For information about the supported hard drives, see the Technical specifications section.

Front panel features of the 10 x 2.5-inch hard drives or SSDs system

Figure 5 Front panel features of the 10 x 2.5-inch hard drives or SSDs system

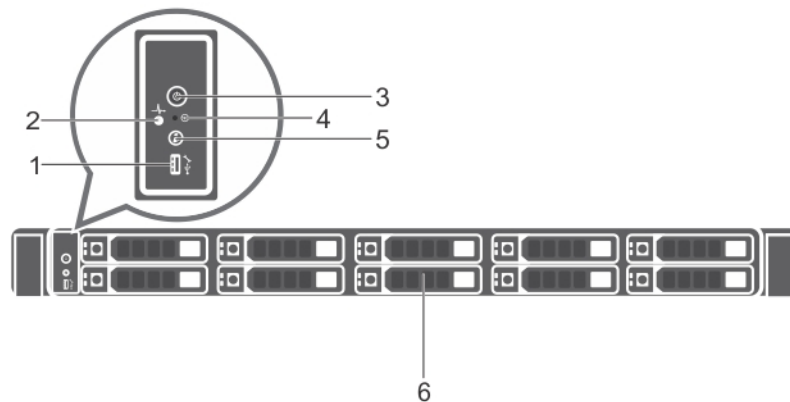

1. USB management port/iDRAC managed USB port
2. Diagnostic indicators
3. Power button
4. NMI button
5. System identification button
6. Hard drives

Front panel features of the 10 x 2.5-inch hard drives or SSDs system

Table 4 Front panel features of the 10 x 2.5-inch hard drives or SSDs system





Item	Indicator, Button, or Connector	Icon	Description
1	USB management port/iDRAC managed USB port		The USB management port is USB 2.0 compliant. Enables you to connect USB devices to the system or provides access to the iDRAC Direct features. For more information, see the Integrated Dell Remote Access Controller User's Guide at Dell.com/idracmanuals .
2	Diagnostic indicators		The diagnostic indicators light up to display error status.

Table 4 Front panel features of the 10 x 2.5-inch hard drives or SSDs system (continued)

Item	Indicator, Button, or Connector	Icon	Description
3	Power button		<p>Press the power button to turn the system on or off. The indicator on the button indicates if the system is on or off.</p> <p>Note: To gracefully shut down an ACPI-compliant operating system, press the power button.</p>
4	NMI button		<p>Press the NMI button to troubleshoot software and device driver errors when running certain operating systems. Use the end of a paper clip to press the NMI button.</p> <p>Note: Use the NMI button only if directed to do so by qualified support personnel or by the operating system documentation.</p>
5	System identification button		<p>Press the system ID button:</p> <ul style="list-style-type: none"> To locate a particular system within a rack. To turn the system ID on or off. <p>To reset iDRAC, press and hold the button for more than 15 seconds.</p> <p>Note: To reset iDRAC using system ID, ensure that the system ID button is enabled in the iDRAC setup.</p> <p>Note: If the system stops responding during POST, press and hold the system ID button (for more than five seconds) to enter the BIOS progress mode.</p>
6	Hard drives		<p>Up to 10 x 2.5 inch hard drives/SSDs. For information about the supported hard drives, see the Technical specifications section.</p>

LCD panel

The LCD panel of your system provides system information, status, and error messages to indicate if the system is functioning correctly or if the system needs attention. For more information about error messages, see the *Dell Event and Error Messages Reference Guide* at [Dell.com/openmanagemanuals >OpenManage software](https://www.dell.com/support/manuals/openmanage).

- The LCD backlight turns blue during normal operating conditions.
- When the system needs attention, the LCD turns amber, and displays an error code followed by descriptive text.
 - Note:** If the system is connected to a power source and an error is detected, the LCD turns amber regardless of whether the system is turned on or off.
- The LCD backlight is turned off when the system is in standby mode and can be turned on by pressing either the Select, Left, or Right button on the LCD panel.

- The LCD backlight remains off if LCD messaging is turned off using the iDRAC utility, the LCD panel, or other tools.

Figure 6 LCD panel features

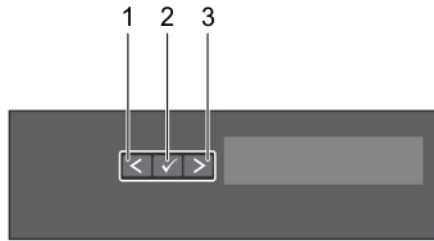

The LCD Panel features table describes the LCD panel buttons: Left, Select and Right, and their functions.



Table 5 LCD panel features

Item	Button	Description
1	Left	Moves the cursor back in one-step increments.
2	Select	Selects the menu item highlighted by the cursor.
3	Right	Moves the cursor forward in one-step increments. During message scrolling: <ul style="list-style-type: none"> • Press and hold the button to increase scrolling speed. • Release the button to stop. <p>Note: The display stops scrolling when the button is released. After 45 seconds of inactivity the display starts scrolling.</p>

Viewing Home screen

The **Home** screen displays user-configurable information about the system. This screen is displayed during normal system operation when there are no status messages or errors. When the system is in standby mode, the LCD backlight turns off after a few minutes of inactivity, if there are no error messages.

Procedure

1. To view the **Home** screen, press one of the three navigation buttons (Select, Left, or Right).
2. To navigate to the **Home** screen from another menu, complete the following steps:
 - a. Press and hold the navigation button till the up arrow  is displayed.
 - b. Navigate to the  using the up arrow .
 - c. Select the **Home** icon.
 - d. On the **Home** screen, press the **Select** button to enter the main menu.

Setup menu

 **Note:** When you select an option in the Setup menu, you must confirm the option before proceeding to the next action.

Option
Description

iDRAC

Select **DHCP** or **Static IP** to configure the network mode. If **Static IP** is selected, the available fields are **IP**, **Subnet (Sub)**, and **Gateway (Gtw)**. Select **Setup DNS** to enable DNS and to view domain addresses. Two separate DNS entries are available.

Set error

Select **SEL** to view LCD error messages in a format that matches the IPMI description in the SEL. This enables you to match an LCD message with an SEL entry.

Select **Simple** to view LCD error messages in a simplified user-friendly description. For more information about error messages, see the *Dell Event and Error Messages Reference Guide* at Dell.com/openmanagemanuals > **OpenManage software**.

Set home

Select the default information to be displayed on the **Home** screen. See View menu section for the options and option items that can be set as the default on the **Home** screen.

View menu

 **Note:** When you select an option in the View menu, you must confirm the option before proceeding to the next action.

Option
Description

iDRAC IP

Displays the **IPv4** or **IPv6** addresses for iDRAC8. Addresses include **DNS (Primary and Secondary)**, **Gateway**, **IP**, and **Subnet** (IPv6 does not have Subnet).

MAC

Displays the MAC addresses for **iDRAC**, **iSCSI**, or **Network** devices.

Name

Displays the name of the **Host**, **Model**, or **User String** for the system.

Number

Displays the **Asset tag** or the **Service tag** for the system.

Power

Displays the power output of the system in BTU/hr or Watts. The display format can be configured in the **Set home** submenu of the **Setup** menu.

Temperature

Displays the temperature of the system in Celsius or Fahrenheit. The display format can be configured in the **Set home** submenu of the **Setup** menu.

Back panel features

The back panel provides access to the features available on the back of the server, such as the system identification button, power supply sockets, cable management arm connectors, iDRAC storage media, NIC ports, and USB and VGA ports. A majority of the expansion card ports can be accessed from the back panel. The hot swappable and cabled power supply units are accessible from the back panel.

Redundant PSU back panel features

Figure 7 Redundant PSU back panel features

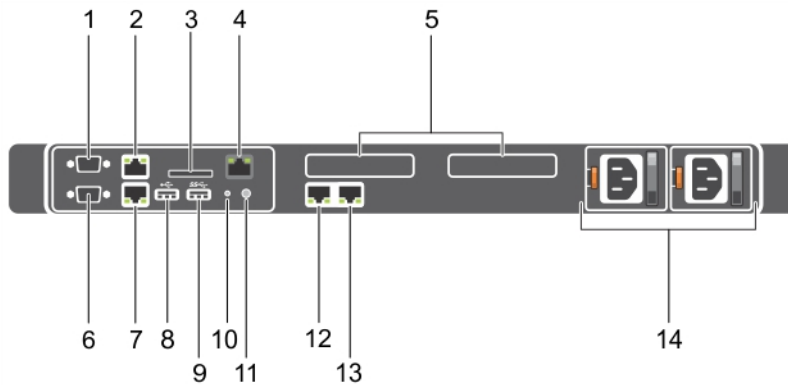

1. Serial connector
2. Ethernet connector 1
3. vFlash card slot (optional)
4. iDRAC port (optional)
5. PCIe expansion card slots (2)
6. Video connector
7. Ethernet connector 2
8. USB connector
9. USB connector
10. System identification button
11. System identification connector
12. Ethernet connector 3
13. Ethernet connector 4
14. Power supply unit (PSU1 and PSU2)

This table describes the redundant PSU back panel features. Item 1 is the serial connector, that enables you to connect a serial device to the system. Item 2 is ethernet connector 1 that supports 10/100/1000 Mbps NIC connectors. Item 3 is the SD vFlash card slot that enables you to insert a vFlash media card. Item 4 is the iDRAC8 Enterprise port. It is a dedicated management port. The port is available for use only if the iDRAC8 Enterprise license is installed on your system. Item 5 is the PCIe expansion card slot, that enables you to connect two low profile PCIe expansion cards. Item 6 is the video connector, that enables you to connect a VGA display to the system. Item 7 is ethernet connector 2 that supports 10/100/1000 Mbps NIC connectors. Item 8 is a USB 2.0

compliant port, that enables you to connect USB devices to the system. Item 9 is a USB 3.0 compliant port, that enables you to connect USB devices to the system. Item 10 is the system identification button on the front and back panels, that can be used to locate a particular system within a rack. When one of these buttons is pressed, the LCD panel on the front and the system status indicator on the back flashes until one of the buttons is pressed again. Press to toggle the system ID on and off. If the system stops responding during POST, press and hold the system ID button for more than five seconds to enter BIOS progress mode. To reset iDRAC (if not disabled in F2 iDRAC setup) press and hold the button for more than 15 seconds. Item 11 is System identification connector, that Enables you to connect the optional system status indicator assembly through the optional cable management arm. Item 12 is ethernet connector 3 that supports 10/100/1000 Mbps NIC connectors. Item 13 is ethernet connector 4 that supports 10/100/1000 Mbps NIC connectors. Item 14 are the power supply units (PSU1 and (PSU2) that are AC PSU's rated at 550 W.

Table 6 Redundant PSU back panel features









Item	Indicator, Button, or Connector	Icon	Description
1	Serial connector		Use the serial port to connect a serial device to the system. For more information about the supported serial port, see the Technical specifications section.
2	Ethernet port 1		Use the Ethernet port to connect Local Area Networks (LANs) to the system. For more information about the supported Ethernet ports, see the Technical specifications section.
3	vFlash card slot (optional)		Use the vFlash media card slot to insert a vFlash media card.
4	iDRAC port (optional)		Use the iDRAC8 Enterprise port to remotely access iDRAC. For more information, see the <i>Integrated Dell Remote Access Controller User's Guide</i> at Dell.com/idracmanuals .
5	PCIe expansion card slots (2)		Enables you to connect two PCI Express expansion cards.
6	Video connector		Use the video/VGA port to connect a display to the system. For more information about the supported video/VGA port, see the Technical specifications section.
7	Ethernet port 2		Use the Ethernet port to connect Local Area Networks (LANs) to the system. For more information about the supported Ethernet ports, see the Technical specifications section.
8	USB port		Use the USB 2.0 port to connect USB devices to the system. This port is 4-pin, USB 2.0 compliant.
9	USB port		Use the USB 3.0 port to connect USB devices to the system. These ports are 9-pin, USB 3.0 compliant.

Table 6 Redundant PSU back panel features (continued)

Item	Indicator, Button, or Connector	Icon	Description
10	System identification button		<p>Press the system ID button:</p> <ul style="list-style-type: none"> To locate a particular system within a rack. To turn the system ID on or off. <p>Note: To reset the iDRAC (if not disabled in F2 iDRAC setup), press and hold the button for more than 15 seconds.</p> <p>Note: If the system stops responding during POST, press and hold the system ID button (for more than five seconds) to enter the BIOS progress mode.</p>
11	System identification port		Use the system identification port to connect the system status indicator assembly through the optional cable management arm.
12	Ethernet port 3		Use the Ethernet port to connect Local Area Networks (LANs) to the system. For more information about the supported Ethernet ports, see the Technical specifications section.
13	Ethernet port 4		
14	Power supply unit (PSU1 and PSU2)		Up to two 550 W redundant AC power supplies.

Cabled PSU back panel features

Figure 8 Cabled PSU back panel features

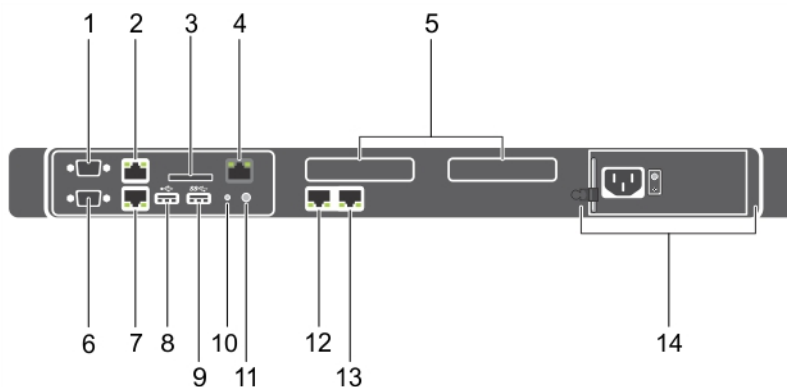
1. Serial connector
2. Ethernet connector 1
3. vFlash card slot (optional)
4. iDRAC port (optional)
5. PCIe expansion card slots (2)
6. Video connector

Figure 8 Cabled PSU back panel features (continued)

- 7. Ethernet connector 2
- 8. USB connector
- 9. USB connector
- 10. System identification button
- 11. System identification connector
- 12. Ethernet connector 3
- 13. Ethernet connector 4
- 14. Cabled PSU

This table describes about Cabled PSU back panel features. Item 1 is the serial connector, that enables you to connect a serial device to the system. Item 2 is ethernet connector 1 that supports 10/100/1000 Mbps NIC connectors. Item 3 is the SD vFlash card slot that enables you to insert a vFlash media card. Item 4 is the iDRAC8 Enterprise port. It is a dedicated management port. The port is available for use only if the iDRAC8 Enterprise license is installed on your system. Item 5 is the PCIe expansion card slot, that enables you to connect two low profile PCIe expansion cards. Item 6 is the video connector, that enables you to connect a VGA display to the system. Item 7 is ethernet connector 2 that supports 10/100/1000 Mbps NIC connectors. Item 8 is a USB 2.0 compliant port, that enables you to connect USB devices to the system. Item 9 is a USB 3.0 compliant port, that enables you to connect USB devices to the system. Item 10 is the system identification button on the front and back panels, that can be used to locate a particular system within a rack. When one of these buttons is pressed, the LCD panel on the front and the system status indicator on the back flashes until one of the buttons is pressed again. Press to toggle the system ID on and off. If the system stops responding during POST, press and hold the system ID button for more than five seconds to enter BIOS progress mode. To reset iDRAC (if not disabled in F2 iDRAC setup) press and hold the button for more than 15 seconds. Item 11 is System identification connector, that Enables you to connect the optional system status indicator assembly through the optional cable management arm. Item 12 is ethernet connector 3 that supports 10/100/1000 Mbps NIC connectors. Item 13 is ethernet connector 4 that supports 10/100/1000 Mbps NIC connectors. Item 14 is the cabled AC PSU rated at 450 W.

Table 7 Cabled PSU back panel features









Item	Indicator, Button, or Connector	Icon	Description
1	Serial connector		Use the serial port to connect a serial device to the system. For more information about the supported serial port, see the Technical specifications section.
2	Ethernet port 1		Use the Ethernet port to connect Local Area Networks (LANs) to the system. For more information about the supported Ethernet ports, see the Technical specifications section.
3	vFlash card slot (optional)		Use the vFlash media card slot to insert a vFlash media card.
4	iDRAC port (optional)		Use the iDRAC8 Enterprise port to remotely access iDRAC. For more information, see the <i>Integrated Dell Remote Access Controller User's Guide</i> at Dell.com/idracmanuals .

Table 7 Cabled PSU back panel features (continued)

Item	Indicator, Button, or Connector	Icon	Description
5	PCIe expansion card slots (2)		Enables you to connect two PCI Express expansion cards.
6	Video connector		Use the video/VGA port to connect a display to the system. For more information about the supported video/VGA port, see the Technical specifications section.
7	Ethernet port 2		Use the Ethernet port to connect Local Area Networks (LANs) to the system. For more information about the supported Ethernet ports, see the Technical specifications section.
8	USB port		Use the USB 2.0 port to connect USB devices to the system. This port is 4-pin, USB 2.0 compliant.
9	USB port		Use the USB 3.0 port to connect USB devices to the system. These ports are 9-pin, USB 3.0 compliant.
10	System identification button		<p>Press the system ID button:</p> <ul style="list-style-type: none"> To locate a particular system within a rack. To turn the system ID on or off. <p>Note: To reset the iDRAC (if not disabled in F2 iDRAC setup), press and hold the button for more than 15 seconds.</p> <p>Note: If the system stops responding during POST, press and hold the system ID button (for more than five seconds) to enter the BIOS progress mode.</p>
11	System identification port		Use the system identification port to connect the system status indicator assembly through the optional cable management arm.
12	Ethernet port 3		Use the Ethernet port to connect Local Area Networks (LANs) to the system. For more information about the supported Ethernet ports, see the Technical specifications section.
13	Ethernet port 4		
14	Power supply unit (PSU)		<p>One 450 W cabled AC PSU.</p> <p>Note: Cabled PSU is supported in systems with cabled hard drives and the systems with x4 backplane.</p>

Diagnostic Indicators

The diagnostic indicators on the system front panel display error status during system startup.

Diagnostic indicators on the front panel

 **Note:** The diagnostic indicators are not present if the system is equipped with an LCD display.

 **Note:** No diagnostic indicators are lit when the system is turned off. To start the system, plug it into a working power source and press the power button.

Item 1 is the health indicator, that indicates the health status of the system. The indicator turns solid blue if the system is turned on and in good health. The indicator flashes amber if the system is turned on or in standby, and if any issue occurs (for example, a failed fan or hard drive). Item 2 is the hard drive indicator, that flashes amber if an error occurs related to hard drive. Item 3 is the electrical indicator that flashes amber if an electrical error occurs (for example, voltage out of range, or a failed power supply unit or voltage regulator). Item 4 is the temperature indicator that flashes amber if a thermal error occurs (for example, a temperature out of range or fan failure). Item 5 is the memory indicator that flashes amber if a memory error occurs. Item 6 is the PCIe indicator that flashes amber if an error occurs related to PCIe card.

Table 8 Diagnostic indicators





Icon	Description	Condition	Corrective action
	Health indicator	<p>The indicator turns solid blue if the system is in good health.</p> <p>The indicator flashes amber:</p> <ul style="list-style-type: none"> When the system is turned on. When the system is in standby. If any error condition exists. For example, a failed fan, PSU, or a hard drive. 	<p>None required.</p> <p>Check the System Event Log or system messages for the specific issue. For more information about error messages, see the <i>Dell Event and Error Messages Reference Guide</i> at Dell.com/openmanagemanuals > OpenManage software.</p> <p>The POST process is interrupted without any video output due to invalid memory configurations. See the Getting help section.</p>
	Hard drive indicator	The indicator flashes amber if there is a hard drive error.	Check the System Event Log to determine the hard drive that has an error. Run the appropriate Online Diagnostics test. Restart the system and run embedded diagnostics (ePSA). If the hard drives are configured in a RAID array, restart the system and enter the host adapter configuration utility program.
	Electrical indicator	The indicator flashes amber if the system experiences an electrical error (for example, voltage out of range, or a	Check the System Event Log or system messages for the specific issue. If it is due to a problem with the PSU, check the LED on the PSU.

Table 8 Diagnostic indicators (continued)

Icon	Description	Condition	Corrective action
	Temperature indicator	failed power supply unit (PSU) or voltage regulator). The indicator flashes amber if the system experiences a thermal error (for example, the ambient temperature is out of range or fan failure).	Reseat the PSU. If the problem persists, see the Getting help section. Ensure that none of the following conditions exist: <ul style="list-style-type: none"> • A cooling fan has been removed or has failed. • System cover, cooling shroud, EMI filler panel, memory module blank, or back filler bracket is removed. • Ambient temperature is too high. • External airflow is obstructed. See the Getting help section.
	Memory indicator	The indicator flashes amber if a memory error occurs.	Check the system event log or system messages for the location of the failed memory. Reseat the memory module. If the problem persists, see the Getting help section.

Hard drive indicator codes

Each hard drive carrier has an activity indicator and a status indicator. The indicators provide information about the current status of the hard drive. The activity LED indicates whether hard drive is currently in use or not. The status LED indicates the power condition of the hard drive.

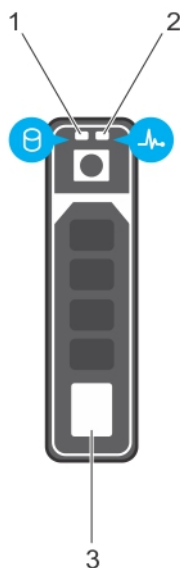
Figure 9 Hard drive indicators

1. hard drive activity indicator
2. hard drive status indicator

Figure 9 Hard drive indicators (continued)

3. hard drive

Note: If the hard drive is in the Advanced Host Controller Interface (AHCI) mode, the status indicator (on the right side) does not turn on.

The Hard drive indicator codes table describes the indicator codes: flashing green, steady green, and amber.

Table 9 Hard drive indicator codes

Drive-status indicator pattern (RAID only)	Condition
Flashes green twice per second	Identifying drive or preparing for removal.
Off	Drive ready for insertion or removal. Note: The drive status indicator remains off until all hard drives are initialized after the system is turned on. Drives are not ready for insertion or removal during this time.
Flashes green, amber, and then turns off	Predicted drive failure
Flashes amber four times per second	Drive failed
Flashes green slowly	Drive rebuilding
Steady green	Drive online
Flashes green for three seconds, amber for three seconds, and then turns off after six seconds	Rebuild stopped

uSATA SSD indicator codes

Figure 10 uSATA SSD indicators



1. uSATA SSD activity indicator
2. uSATA SSD status indicator
3. uSATA SSD

Note: If the SSD is in the Advanced Host Controller Interface (AHCI) mode, the status indicator (on the right side) does not function and remains off.

The following table contains the drive LED indicator pattern with the drive status.

Table 10 Drive status indicator codes

Drive-status indicator pattern	Condition
Flashes green twice per second	Identifying drive or preparing for removal.
Off	Drive ready for insertion or removal. <i>Note:</i> The drive status indicator remains off until all hard drives are initialized after the system is turned on. Drives are not ready for insertion or removal during this time.
Flashes green, amber, and turns off	Predicted drive failure
Flashes amber four times per second	Drive failed
Steady green	Drive online
Flashes green for three seconds, amber for three seconds, and turns off after six seconds	Rebuild aborted

NIC indicator codes

Each NIC on the back panel has an indicator that provides information about the network activity and link status. The activity LED indicates whether the NIC is currently connected or not. The link LED indicates the speed of the connected network.

Figure 11 NIC indicators

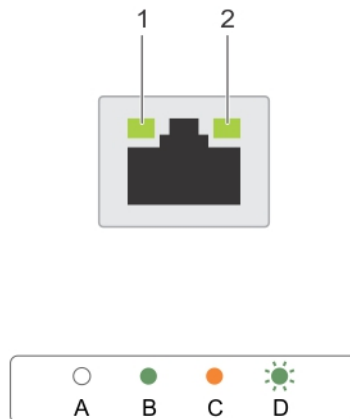

1. link indicator
2. activity indicator

The NIC indicators table describes different NIC indicator codes and condition of the connectivity.

Table 11 NIC indicators

Convention	Status	Condition
A	Link and activity indicators are off	The NIC is not connected to the network.
B	Link indicator is green	The NIC is connected to a valid network at its maximum port speed (1 Gbps or 10 Gbps).
C	Link indicator is amber	The NIC is connected to a valid network at less than its maximum port speed.
D	Activity indicator is flashing green	Network data is being sent or received.

Internal dual SD module indicator codes

The Internal Dual SD module (IDSDM) provides you with a redundant SD card solution. You can configure the IDSDM for storage or as the OS boot partition. The IDSDM card offers the following features:

- Dual card operation — maintains a mirrored configuration by using SD cards in both the slots and provides redundancy.
 - ⓘ **Note:** When the Redundancy option is set to Mirror Mode in the Integrated Devices screen of System Setup, the information is replicated from one SD card to another.
- Single card operation — single card operation is supported, but without redundancy.

Figure 12 Internal dual SD module (IDSDM)

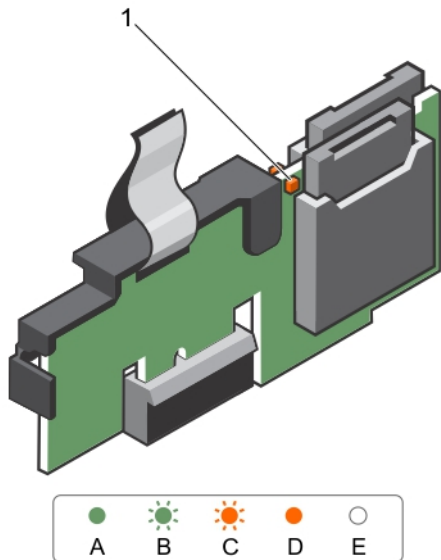

1. LED status indicator (2)

The following table describes the IDSDM indicator codes:

The IDSDM indicator glows green when the card is online. The IDSDM indicator flashes green to indicate rebuild or activity. The IDSDM indicator flashes amber to indicate card mismatch or that

the card has failed. The IDSDM indicator does not glow to indicate that the card is missing or is booting.

Table 12 IDSDM indicator codes

Convention	IDSDM indicator code	Description
A	Green	Indicates that the card is online.
B	Flashing green	Indicates rebuild or activity.
C	Flashing amber	Indicates card mismatch or that the card has failed.
D	Amber	Indicates that the card is offline, has failed, or is write-protected.
E	Not lit	Indicates that the card is missing or is booting.

iDRAC Direct LED indicator codes

The iDRAC Direct LED indicator lights up to indicate that the port is connected and is being used as a part of the iDRAC subsystem.

Note: The iDRAC Direct LED indicator does not turn on when the USB port is used in the USB mode.

Figure 13 iDRAC Direct LED indicator

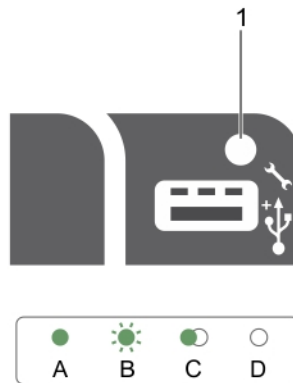

1. iDRAC Direct status indicator

The iDRAC Direct LED indicator table describes iDRAC Direct activity when configuring iDRAC Direct by using the management port (USB XML Import).

This table describes the iDRAC Direct status indicators and what is the condition when the LED flashes green, continuously flashes green and when it's not lit.

Table 13 iDRAC Direct LED indicators

Convention	iDRAC Direct LED indicator pattern	Condition
A	Green	Turns green for a minimum of two seconds to indicate the start and end of a file transfer.
B	Flashing green	Indicates file transfer or any operation tasks.
C	Green and turns off	Indicates that the file transfer is complete.
D	Not lit	Indicates that the USB is ready to be removed or that a task is complete.

The following table describes iDRAC Direct activity when configuring iDRAC Direct by using your laptop and cable (Laptop Connect):

The iDRAC Direct LED indicator patterns table describes the iDRAC status when it is solid green, flashing green, and when it is turned off.

Table 14 iDRAC Direct LED indicator patterns

iDRAC Direct LED indicator pattern	Condition
Solid green for two seconds	Indicates that the laptop is connected.
Flashing green (on for two seconds and off for two seconds)	Indicates that the laptop connected is recognized.
Turns off	Indicates that the laptop is unplugged.

Indicator codes for redundant power supply unit

Each AC power supply unit (PSU) has an illuminated translucent handle that indicates whether power is present or whether a power fault has occurred.

Figure 14 AC PSU status indicator



1. AC PSU status indicator or handle

This table describes about AC PSU status indicator.

Table 15 Redundant AC PSU status indicator

Convention	Power Indicator Pattern	Condition
A	Green	A valid power source is connected to the PSU and the PSU is operational.
B	Flashing green	When the PSU firmware is being updated, the PSU handle flashes green. ⚠ CAUTION Do not disconnect the power cord or unplug the PSU when updating firmware. If firmware update is interrupted, the PSUs will not function. You must roll back the PSU firmware by using Dell Lifecycle Controller. For more information, see Dell Lifecycle Controller User's Guide at Dell.com/idracmanuals .
C	Flashing green and turns off	When hot-adding a PSU, the PSU handle flashes green five times at 4 Hz rate and turns off. This indicates that there is a PSU mismatch with respect to efficiency, feature set, health status, and supported voltage. ⚠ CAUTION For AC PSUs, use only PSUs with the Extended Power Performance (EPP) label on the back. ⓘ Note: Ensure that both the PSUs are of the same capacity. ⓘ Note: Mixing PSUs from previous generations of Dell PowerEdge servers can result in a PSU mismatch condition or failure to turn the system on.
D	Flashing amber	Indicates a problem in the PSU. ⚠ CAUTION When correcting a PSU mismatch, replace only the PSU with the flashing indicator. Swapping the other

Table 15 Redundant AC PSU status indicator (continued)

Convention	Power Indicator Pattern	Condition
		<p>PSU to make a matched pair can result in an error condition and unexpected system shutdown. To change from a High Output configuration to a Low Output configuration or vice versa, you must turn off the system.</p> <p>CAUTION AC PSUs support both 220 V and 110 V input voltages with the exception of Titanium PSUs, which support only 220 V. When two identical PSUs receive different input voltages, they can output different wattages, and trigger a mismatch.</p> <p>CAUTION If two PSUs are used, they must be of the same type and have the same maximum output power.</p> <p>CAUTION Combining AC and DC PSUs is not supported and triggers a mismatch.</p>
E	Not lit	Power is not connected.

Non-redundant power supply unit indicator codes

Press the self-diagnostic button to perform a quick health check on the non-redundant power supply unit (PSU) of the system.

Figure 15 Non-redundant AC PSU status indicator and self-diagnostic button

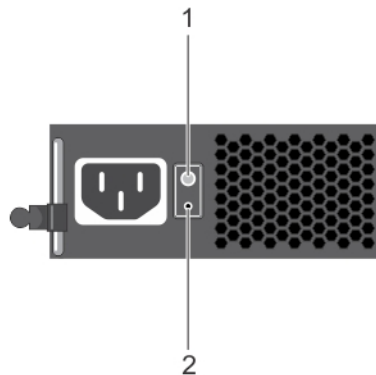

1. self-diagnostic button
2. AC PSU status indicator

This table describes about non-redundant AC PSU status indicator.

Table 16 Non-redundant AC PSU status indicator

Power Indicator Pattern	Condition
Not lit	Power is not connected or PSU is faulty.

Table 16 Non-redundant AC PSU status indicator (continued)

Power Indicator Pattern	Condition
Green	A valid power source is connected to the PSU and the PSU is operational.

Locating Service Tag of your system

Your system is identified by a unique Express Service Code and Service Tag number. The Express Service Code and Service Tag are found on the front of the system by pulling out the information tag. Alternatively, the information may be on a sticker on the chassis of the system. This information is used by Dell to route support calls to the appropriate personnel.

CHAPTER 2

Documentation resources

This section provides information about the documentation resources for your system.

The following describes the additional information about the resources available to operate your system.

Table 17 Documentation resources for system

Task	Document	Location
Setting up your system	For information about installing the system into a rack, see the Rack documentation included with your rack solution.	Dell.com/poweredgemanuals
	For information about turning on the system and the technical specifications of your system, see the <i>Getting Started With Your System</i> document that is shipped with your system.	Dell.com/poweredgemanuals
Configuring your system	For information about iDRAC features, configuring and logging in to iDRAC, and managing your system remotely, see the Integrated Dell Remote Access Controller User's Guide.	Dell.com/idracmanuals
	For information about installing the operating system, see the operating system documentation.	Dell.com/operatingsystemmanuals
	For information about understanding Remote Access Controller Admin (RACADM) subcommands and supported RACADM interfaces, see the RACADM Command Line Reference Guide for iDRAC.	Dell.com/idracmanuals
	For information about updating drivers and firmware, see the Methods to download firmware and drivers section in this document.	Dell.com/support/drivers
Managing your system	For information about the features of the Dell OpenManage Systems Management, see the Dell	Dell.com/openmanagemanuals

Table 17 Documentation resources for system (continued)

Task	Document	Location
	OpenManage Systems Management Overview Guide.	
	For information about setting up, using, and troubleshooting OpenManage, see the Dell OpenManage Server Administrator User's Guide.	Dell.com/openmanagemanuals
	For information about installing, using, and troubleshooting Dell OpenManage Essentials, see the Dell OpenManage Essentials User's Guide.	Dell.com/openmanagemanuals
	For information about installing and using Dell System E-Support Tool (DSET), see the Dell System E-Support Tool (DSET) User's Guide.	Dell.com/DSET
	For information about installing and using Active System Manager (ASM), see the Active System Manager User's Guide.	Dell.com/asmdocs
	For understanding the features of Dell Lifecycle Controller (LCC), see the Dell Lifecycle Controller User's Guide.	Dell.com/idracmanuals
	For information about partner programs enterprise systems management, see the OpenManage Connections Enterprise Systems Management documents.	Dell.com/omconnectionsenterprisesystemsmanagement
	For information about connections and client systems management, see the OpenManage Connections Client Systems Management documentation.	Dell.com/dellclientcommandsuitemanuals
	For information about viewing inventory, performing configuration and monitoring tasks, remotely turning on or off servers, and enabling alerts for events on servers and components using the Dell Chassis Management Controller (CMC), see the CMC User's Guide.	Dell.com/esmmanuals

Table 17 Documentation resources for system (continued)

Task	Document	Location
Working with Dell PowerEdge RAID controllers	For information about understanding the features of the Dell PowerEdge RAID controllers (PERC) and deploying the PERC cards, see the Storage controller documentation.	Dell.com/storagecontrollermanuals
Understanding event and error messages	For information about checking the event and error messages generated by the system firmware and agents that monitor system components, see the Dell Event and Error Messages Reference Guide.	Dell.com/openmanagemanuals > OpenManage software

CHAPTER 3

Technical specifications

The technical and environmental specifications of your system are outlined in this section.

- [Chassis dimensions](#).....42
- [Chassis weight](#)..... 42
- [Processor specifications](#).....43
- [PSU specifications](#)..... 43
- [System battery specifications](#)..... 43
- [Expansion bus specifications](#)..... 43
- [Memory specifications](#)..... 44
- [Drive specifications](#)..... 44
- [Ports and connectors specifications](#).....45
- [Video specifications](#).....46
- [Environmental specifications](#)..... 46

Chassis dimensions

This section describes the physical dimensions of the system.

Figure 16 Chassis dimensions of the PowerEdge R430 system

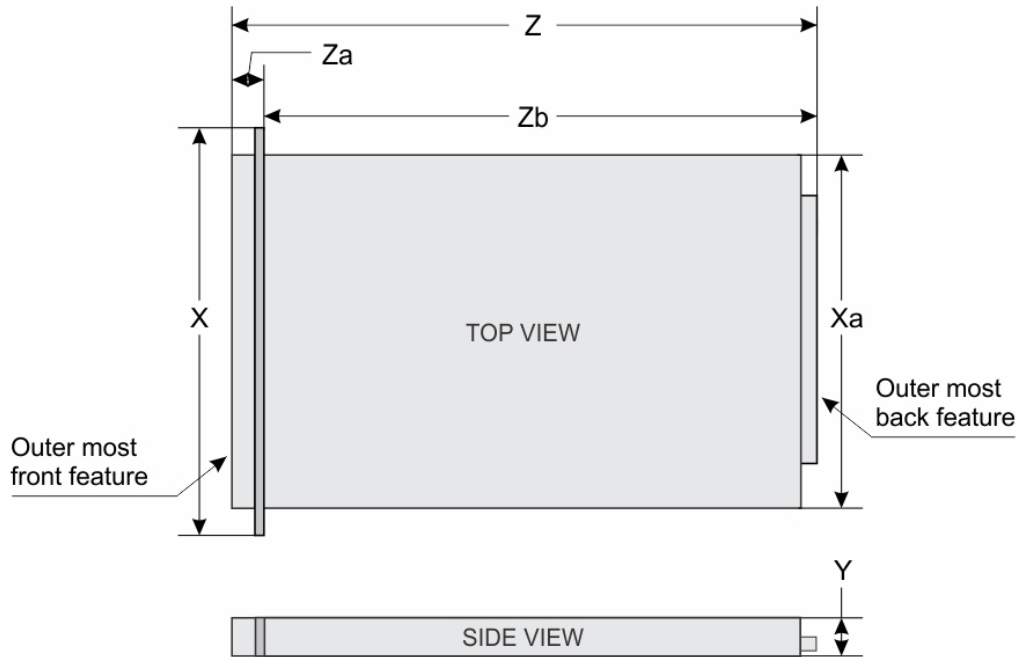

This table gives details of the dimensions of the Dell PowerEdge R430 system. The dimensions are as follows: X = 482.4 mm, Xa = 434.0 mm, Y = 42.8 mm, Z(with bezel)= 677.3 mm, Z (without bezel) = 662.4 mm, Za (with bezel) = 35.0 mm, Za (without bezel) = 20.1 mm, and Zb=642.3 mm.

Table 18 Dimensions of the Dell PowerEdge R430 system

X	Xa	Y	Z (with bezel)	Z (without bezel)	Za (with bezel)	Za (without bezel)	Zb
482.4 mm (18.99 inches)	434.0 mm (17.08 inches)	42.8 mm (1.68 inches)	677.3 mm (26.66 inches)	662.4 mm (264.07 inches)	35.0 mm (1.37 inches)	20.1 mm (0.79 inches)	642.3 mm (25.28 inches)

Chassis weight

This section describes the weight of the system.

For PowerEdge R430 systems, the maximum chassis weight is 19.9 kg (43.87 lb).

Table 19 Chassis weight

System	Maximum weight (with all hard drives/SSDs)
PowerEdge R430	19.9 kg (43.87 lb)

Processor specifications

The PowerEdge R430 system supports up to two Intel Xeon E5-2600 v3 or Intel Xeon E5-2600 v4 product family processors.

PSU specifications

The PowerEdge R430 system supports up to two AC redundant power supply units (PSUs) and a single AC cabled PSU.

For 550 W AC, platinum power supply unit, the maximum heat dissipation is 2107 BTU/hr, frequency is 50/60 Hz, and voltage range is 100-240 V AC autoranging and the current rating is between 7.4 A-3.7 A. For 450 W AC Bronze PSU, the maximum heat dissipation is 1871 BTU/hr, frequency is 50/60 Hz, and voltage range is 100-240 V AC autoranging and the current rating is between 6.5 A-3.5 A.

Table 20 PSU specifications

PSU	Class	Heat dissipation (maximum)	Frequency	Voltage	Current
550 W AC	Platinum	2107 BTU/hr	50/60 Hz	100–240 V AC, autoranging	7.4 A-3.7 A
450 W AC	Bronze	1871 BTU/hr	50/60 Hz	100–240 V AC, autoranging	6.5 A-3.5 A

Note: Heat dissipation is calculated using the PSU wattage rating.

Note: This system is also designed to connect to the IT power systems with a phase-to-phase voltage not exceeding 230 V.

System battery specifications

The PowerEdge R430 system supports 3 V CR2032 Lithium coin cell system battery.

Expansion bus specifications

The PowerEdge R430 system supports PCI express (PCIe) Generation 2 and 3 expansion cards, which need to be installed on the system board using expansion card risers. This system supports two types of expansion card risers. The following table provides the expansion card riser specifications:

This table describes the details of the PCIe slots on the expansion card risers. PCIE_G3_X16 riser supports PCIe slots 1 and 2 with low-profile, half-length, x16 link speed cards. PCIE_G3_X8 riser supports two PCIe cards on slots 1 and 2 with a full height, low profile, x8 link speed cards on slot 1 and a low-profile, half-length, x8 link speed card on slot 2

Table 21 Expansion card riser specifications

Expansion card riser	PCIe slots on the riser	Height	Length	Link
PCIe_G3_X16 riser	Slot 1	low-profile	half-length	x16
	Slot 2	low-profile	half-length	x16
PCIe_G3_X8 riser	Slot 1	full-height	half-length	x8
	Slot 2	low-profile	half-length	x8

Memory specifications

The PowerEdge R430 system supports DDR4 registered DIMMs (RDIMMs) and load-reduced DIMMs (LRDIMMs). Supported memory bus frequencies are 1866 MT/s, 2133MT/s, or 2400 MT/s.

Your system supports 12 memory module sockets of 288-pins each. The system supports RDIMMs of memory capacity 4 GB or 8 GB single rank, and RDIMMs of memory capacity 8 GB, 16 GB, or 32 GB dual rank. For system with single processor, the minimum RAM is 4 GB and the maximum RAM is up to 256 GB. For system with dual processor, the minimum RAM is 8 GB (minimum one memory module per processor) and the maximum RAM is up to 384 GB.

Table 22 Memory specifications

Memory module sockets	Memory capacity	Minimum RAM	Maximum RAM
Twelve 288-pin	<ul style="list-style-type: none"> 4 GB single rank (RDIMMs) 8 GB, 16 GB, or 32 GB dual rank (RDIMMs) 	<ul style="list-style-type: none"> 4 GB with single processor 8 GB with dual processors (minimum one memory module per processor) 	<ul style="list-style-type: none"> Up to 256 GB with a single processor Up to 384 GB with a dual processor

Drive specifications

Hard drives

The PowerEdge R430 system supports SAS, SATA, Nearline SAS hard drives and Solid State Drives (SSDs).

This table lists out the supported hard drive and SSD options for the PowerEdge 430 system.

Table 23 Supported hard drive and SSD options for the PowerEdge R430 system

Four hard drive systems	Up to four 3.5-inch cabled hard drives, or Up to four 3.5-inch hot-swappable SAS, SATA, or Nearline SAS hard drives, or
-------------------------	--

Table 23 Supported hard drive and SSD options for the PowerEdge R430 system (continued)

	<p>Up to four 2.5-inch hot-swappable SAS, SATA, SATA SSD, or Nearline SAS hard drives.</p> <p>Note: Four hard-drive systems support software RAID. For more information about software RAID, see the Dell PowerEdge RAID Controller (PERC) documentation at dell.com/storagecontrollermanuals.</p>
Eight hard-drive systems	Up to eight 2.5-inch, hot-swappable SAS, SATA, SATA SSD, or Nearline SAS hard drives
Ten hard-drive systems	Up to ten 2.5-inch, hot-swappable SATA hard drive or SATA SSD

Optical drive

The PowerEdge R430 system supports one optional SATA DVD-ROM drive or DVD+/-RW drive.

Note: The optical drive is supported on the four hard-drive systems and eight hard-drive systems.

Ports and connectors specifications

USB ports

The PowerEdge R430 system supports:

- USB 2.0-compliant ports on the front panel
- USB 3.0-compliant and USB 2.0-compliant ports on the back panel
- USB 3.0-compliant internal port

The following table provides more information about the USB specifications:

The PowerEdge R430 system supports two 4-pin, USB 2.0-compliant ports on the front panel. Your system supports one 9-pin, USB 3.0-compliant port and one 4-pin, USB 2.0-compliant port on the back panel and one 9-pin, USB 3.0-compliant internal port.

Table 24 USB specifications

System	Front panel	Back panel	Internal
PowerEdge R430	Two 4-pin, USB 2.0-compliant ports	One 9-pin, USB 3.0-compliant port One 4-pin, USB 2.0-compliant port	One 9-pin, USB 3.0-compliant port

NIC ports

The PowerEdge R430 system supports four 10/100/1000 Mbps Network Interface Controller (NIC) ports on the back panel.

Serial connector

The serial connector connects a serial device to the system. The PowerEdge R430 system supports one serial connector on the back panel, which is a 9-pin connector, Data Terminal Equipment (DTE), 16550-compliant.

VGA ports

The Video Graphic Array (VGA) port enables you to connect the system to a VGA display. The PowerEdge R430 system supports two 15-pin VGA ports one each on the front and back panels.

Internal Dual SD Module

The PowerEdge R430 system supports two optional flash memory card slots with an internal dual SD module.

 **Note:** One card slot is dedicated for redundancy.

Video specifications

The PowerEdge R430 system supports Matrox G200 graphics card with 16 MB capacity. For 640 x 480 resolution, the refresh rate is 60 to 70 Hz and the color depth is 8, 16, 32 bit. For 800 x 600 resolution, the refresh rate is 60, 75, 85 Hz and color depth is 8, 16, 32 bit. For 1024 x 768 resolution, the refresh rate is 60, 75, 85 Hz and color depth is 8, 16, 32 bit. For 1152 x 864 resolution, the refresh rate is 60, 75, 85 Hz and color depth is 8, 16, 32 bit. For 1280 x 1024 resolution, the refresh rate is 60, 75 Hz and color depth is 8, 16, 32 bit. For 1440 x 900 resolution, the refresh rate is 60 Hz and color depth is 8, 16, 32 bit.

Table 25 Supported video resolution options

Resolution	Refresh rate (Hz)	Color depth (bits)
640 x 480	60, 70	8, 16, 32
800 x 600	60, 75, 85	8, 16, 32
1024 x 768	60, 75, 85	8, 16, 32
1152 x 864	60, 75, 85	8, 16, 32
1280 x 1024	60, 75	8, 16, 32
1440 x 900	60	8, 16, 32

Environmental specifications

 **Note:** For additional information about environmental measurements for specific system configurations, see Dell.com/environmental_datasheets.

When the system is in continuous operation (for altitude less than 950 m or 3117 ft), the temperature specification ranges from 10°C to 35°C (50°F to 95°F) with no direct sunlight on the equipment. NOTE: Maximum of 145 W 22 core processor is supported in systems with eight 2.5-inches drives, two PCI slot chassis, and 75 W single wide active GPU. When the system is not in operation, the temperature specification is -40°C to 65°C (-40°F to 149°F). The Maximum temperature gradient for both operation and non-operational systems is 20°C/h (36°F/h).

Table 26 Temperature specifications

Temperature	Specifications
Storage	-40°C to 65°C (-40°F to 149°F)
Continuous operation (for altitude less than 950 m or 3117 ft)	10°C to 35°C (50°F to 95°F) with no direct sunlight on the equipment.
Maximum temperature gradient (operating and storage)	20°C/h (36°F/h)

For a non-operational system, the ambient relative humidity ranges from 5% to 95% with 33°C (91°F) maximum dew point. Atmosphere must be non-condensing at all times. For an operational system, the ambient relative humidity ranges from 10% to 80% with 29°C (84.2°F) maximum dew point.

Table 27 Relative humidity specifications

Relative humidity	Specifications
Storage	5% to 95% RH with 33°C (91°F) maximum dew point. Atmosphere must be non-condensing at all times.
Operating	10% to 80% relative humidity with 29°C (84.2°F) maximum dew point.

The maximum vibration specification of an operational system is 0.26 Grms at 5 Hz to 350 Hz (all operation orientations). The maximum vibration specification of a non-operational system is 1.88 Grms at 10 Hz to 500 Hz for 15 min (all six sides tested).

Table 28 Maximum vibration specifications

Maximum vibration	Specifications
Operating	0.26 G _{rms} at 5 Hz to 350 Hz (all operation orientations).
Storage	1.88 G _{rms} at 10 Hz to 500 Hz for 15 min (all six sides tested).

The maximum shock specification of an operational system is six consecutively executed shock pulses in the positive and negative x, y, and z axes of 40 G for up to 2.3 ms. The maximum shock specification of a non-operational system is six consecutively executed shock pulses in the positive and negative x, y, and z axes (one pulse on each side of the system) of 71 G for up to 2 ms.

Table 29 Maximum shock specifications

Maximum shock	Specifications
Operating	Six consecutively executed shock pulses in the positive and negative x, y, and z axes of 40 G for up to 2.3 ms.
Storage	Six consecutively executed shock pulses in the positive and negative x, y, and z axes (one pulse on each side of the system) of 71 G for up to 2 ms.

The maximum altitude specification for an operational system is 3048 m (10,000 ft). The maximum altitude specification for a non-operational system is 12,000 m (39,370 ft).

Table 30 Maximum altitude specifications

Maximum altitude	Specifications
Operating	30482000 m (10,0006560 ft)
Storage	12,000 m (39,370 ft)

If the operating temperature of a system is up to 35 °C (95 °F), the maximum temperature is reduced by 1 °C/300 m (1 °F/547 ft) above 950 m (3,117 ft). If the operating temperature of a system ranges from 35 °C to 40 °C (95 °F to 104 °F), the maximum temperature is reduced by 1 °C/175 m (1 °F/319 ft) above 950 m (3,117 ft). If the operating temperature of a system ranges from 40 °C to 45 °C (104 °F to 113 °F), the maximum temperature is reduced by 1 °C/125 m (1 °F/228 ft) above 950 m (3,117 ft).

Table 31 Operating temperature de-rating specifications

Operating temperature de-rating	Specifications
Up to 35°C (95°F)	Maximum temperature is reduced by 1°C/300 m (1°F/547 ft) above 950 m (3,117 ft).
35°C to 40°C (95°F to 104°F)	Maximum temperature is reduced by 1°C/175 m (1°F/319 ft) above 950 m (3,117 ft).
40°C to 45°C (104°F to 113°F)	Maximum temperature is reduced by 1°C/125 m (1°F/228 ft) above 950 m (3,117 ft).

Particulate and gaseous contamination specifications



The following table defines the limitations that help avoid any equipment damage or failure from particulates and gaseous contamination. If the levels of particulates or gaseous pollution exceed the specified limitations and result in equipment damage or failure, you may need to rectify the environmental conditions. Re-mediation of environmental conditions is the responsibility of the customer.

Air filtration specification: Data center air filtration as defined by ISO Class 8 per ISO 14644-1 should have a 95% upper confidence limit. **Note:** This condition applies only to data center environments. Air filtration requirements do not apply to IT equipment designed to be used outside a data center, in environments such as an office or factory floor. **Note:** Air entering the data center must have MERV11 or MERV13 filtration. **Conductive dust specification:** Air must be free of conductive dust, zinc whiskers, or other conductive particles. **Note:** This condition applies to data center and non-data center environments. **Corrosive dust specification:** Air must be free of corrosive dust. Residual dust present in the air must have a deliquescent point less than 60% relative humidity. **Note:** This condition applies to data center and non-data center environments.

Table 32 Particulate contamination specifications

Particulate contamination	Specifications
Air filtration	Data center air filtration as defined by ISO Class 8 per ISO 14644-1 with a 95% upper confidence limit. <i>i</i> Note: This condition applies to data center environments only. Air filtration requirements do not apply to IT equipment designed to be used outside a data center, in environments such as an office or factory floor.

Table 32 Particulate contamination specifications (continued)

Particulate contamination	Specifications
	<p> Note: Air entering the data center must have MERV11 or MERV13 filtration.</p>
Conductive dust	<p>Air must be free of conductive dust, zinc whiskers, or other conductive particles.</p> <p> Note: This condition applies to data center and non-data center environments.</p>
Corrosive dust	<ul style="list-style-type: none"> Air must be free of corrosive dust. Residual dust present in the air must have a deliquescent point less than 60% relative humidity. <p> Note: This condition applies to data center and non-data center environments.</p>

The copper coupon corrosion rate is <300 Å/month per Class G1 as defined by ANSI/ISA71.04-1985. The silver coupon corrosion rate is <200 Å/month as defined by AHSRAE TC9.9.

Table 33 Gaseous contamination specifications

Gaseous contamination	Specifications
Copper coupon corrosion rate	<300 Å/month per Class G1 as defined by ANSI/ISA71.04-1985.
Silver coupon corrosion rate	<200 Å/month as defined by AHSRAE TC9.9.

 **Note:** Maximum corrosive contaminant levels measured at ≤50% relative humidity.

Expanded operating temperature

When the system is at 10% of annual operating hours, the expanded operating temperature ranges from 5°C to 40°C at 5% to 85% RH with 29°C dew point. NOTE: Outside the standard operating temperature (10°C to 35°C), the system can operate continuously in temperatures as low as 5°C and as high as 40°C. For temperatures between 35°C and 40°C, de-rate maximum allowable dry bulb temperature by 1°C per 175 m above 950 m (1°F per 319 ft). When the system is operating at < 1% of annual operating hours, the expanded operating temperature is –5°C to 45°C at 5% to 90% RH with 29°C dew point. NOTE: Outside the standard operating temperature (10°C to 35°C), the system can operate down to –5°C or up to 45°C for a maximum of 1% of its annual operating hours. For temperatures between 40°C and 45°C, de-rate maximum allowable temperature by 1°C per 125 m above 950 m (1°F per 228 ft).

Table 34 Expanded operating temperature specifications





Expanded operating temperature	Specifications
Continuous operation	<p>5°C to 40°C at 5% to 85% RH with 29°C dew point.</p> <p> Note: Outside the standard operating temperature (10°C to 35°C), the system can operate continuously in temperatures as low as 5°C and as high as 40°C.</p>

Table 34 Expanded operating temperature specifications (continued)

Expanded operating temperature	Specifications
	For temperatures between 35°C and 40°C, de-rate maximum allowable dry bulb temperature by 1°C per 175 m above 950 m (1°F per 319 ft).
≤ 1% of annual operating hours	<p data-bbox="770 447 1326 506">–5°C to 45°C at 5% to 90% RH with 29°C dew point.</p> <p data-bbox="770 510 1294 632">  Note: Outside the standard operating temperature (10°C to 35°C), the system can operate down to –5°C or up to 45°C for a maximum of 1% of its annual operating hours. </p> <p data-bbox="770 653 1321 743">For temperatures between 40°C and 45°C, de-rate maximum allowable temperature by 1°C per 125 m above 950 m (1°F per 228 ft).</p>

 **Note:** When operating in the expanded temperature range, system performance may be impacted.

 **Note:** When operating in the expanded temperature range, ambient temperature warnings maybe reported on the LCD panel and in the System Event Log.

Expanded operating temperature restrictions

- Processors of 55 W and 65 W are not supported.
- Do not perform a cold startup below 5°C.
- Allow processor performance degrade.
- Non-redundant power supplies are not supported.
- Non Dell qualified peripheral cards and/or peripheral cards are not supported.
- Maximum altitude for the operating temperature must be 3050 m (10,000 ft).

CHAPTER 4

Initial system setup and configuration

- [Setting up your system](#)..... 52
- [iDRAC configuration](#)..... 52
- [Options to install the operating system](#)..... 53

Setting up your system

Complete the following steps to set up your system:

Procedure

1. Unpack the system.
2. Install the system into the rack. For more information about installing the system into the rack, see your system *Rack Installation Placemat* at Dell.com/poweredgemanuals.
3. Connect the peripherals to the system.
4. Connect the system to its electrical outlet.
5. Turn the system on by pressing the power button or by using iDRAC.
6. Turn on the attached peripherals.

iDRAC configuration

The Integrated Dell Remote Access Controller (iDRAC) is designed to make system administrators more productive and improve the overall availability of Dell systems. iDRAC alerts administrators to system issues, helps them perform remote system management, and reduces the need for physical access to the system.

Options to set up iDRAC IP address

You must configure the initial network settings based on your network infrastructure to enable the communication to and from iDRAC. You can set up the IP address by using one of the following interfaces:

Interfaces

Document/Section

iDRAC Settings utility

See *Dell Integrated Dell Remote Access Controller User's Guide* at Dell.com/idracmanuals

Dell Deployment Toolkit

See *Dell Deployment Toolkit User's Guide* at Dell.com/openmanagemanuals

Dell Lifecycle Controller

See *Dell Lifecycle Controller User's Guide* at Dell.com/idracmanuals

Chassis or Server LCD panel

See the LCD panel section

You must use the default iDRAC IP address 192.168.0.120 to configure the initial network settings, including setting up DHCP or a static IP for iDRAC.

Note: To access iDRAC, ensure that you install the iDRAC port card or connect the network cable to the Ethernet connector 1 on the system board.

Note: Ensure that you change the default user name and password after setting up the iDRAC IP address.

Log in to iDRAC

You can log in to iDRAC as:

- iDRAC user
- Microsoft Active Directory user
- Lightweight Directory Access Protocol (LDAP) user

The default user name and password are `root` and `calvin`. You can also log in by using Single Sign-On or Smart Card.

 **Note:** You must have iDRAC credentials to log in to iDRAC.

For more information about logging in to iDRAC and iDRAC licenses, see the *Integrated Dell Remote Access Controller User's Guide* at Dell.com/idracmanuals.

Options to install the operating system

If the system is shipped without an operating system, install the supported operating system by using one of the following resources:

This section provides the resources of installing the OS.

Table 35 Resources to install the operating system

Resources	Location
Dell Systems Management Tools and Documentation media	Dell.com/operatingsystemmanuals
Dell Lifecycle Controller	Dell.com/idracmanuals
Dell OpenManage Deployment Toolkit	Dell.com/openmanagemanuals
Dell certified VMware ESXi	Dell.com/virtualizationsolutions
Supported operating systems on Dell PowerEdge systems	Dell.com/ossupport
Installation and How-to videos for supported operating systems on Dell PowerEdge systems	Supported Operating Systems for Dell PowerEdge Systems

Methods to download firmware and drivers

You can download the firmware and drivers by using any of the following methods:

You can download the firmware and drivers from Dell support site at Dell.com/support/home, You can download the firmware and drivers from by using Dell Remote Access Controller Lifecycle Controller (iDRAC with LC) at Dell.com/idracmanuals. You can download the firmware and drivers by using Dell Repository Manager, Dell OpenManage Essentials, Dell Server Update Utility, Dell OpenManage Deployment Toolkit at Dell.com/openmanagemanuals.

Table 36 Firmware and drivers

Methods	Location
From the Dell Support site	Dell.com/support/home
Using Dell Remote Access Controller Lifecycle Controller (iDRAC with LC)	Dell.com/idracmanuals
Using Dell Repository Manager (DRM)	Dell.com/openmanagemanuals
Using Dell OpenManage Essentials (OME)	Dell.com/openmanagemanuals

Table 36 Firmware and drivers (continued)

Methods	Location
Using Dell Server Update Utility (SUU)	Dell.com/openmanagemanuals
Using Dell OpenManage Deployment Toolkit (DTK)	Dell.com/openmanagemanuals

Downloading the drivers and firmware

Dell recommends that you download and install the latest BIOS, drivers, and systems management firmware on your system.

Before you begin

Ensure that you clear the web browser cache before downloading the drivers and firmware.

Procedure

1. Go to Dell.com/support/drivers.
2. Under the **Drivers & Downloads** section, type the Service Tag of your system in the **Service Tag or Express Service Code** box.

 **Note:** If you do not have the Service Tag, select **Detect My Product** to allow the system to automatically detect your Service Tag, or under General support, navigate to your product.

3. Click **Drivers & Downloads**.

The drivers that are applicable to your selection are displayed.

4. Download the drivers you need to a USB drive, CD, or DVD.

CHAPTER 5

Pre-operating system management applications

You can manage basic settings and features of a system without booting to the operating system by using the system firmware.

- [Options to manage the pre-operating system applications](#)..... 56
- [System Setup](#)..... 56
- [Dell Lifecycle Controller](#)..... 81
- [Boot Manager](#)..... 81
- [PXE boot](#)..... 82

Options to manage the pre-operating system applications

Your system has the following options to manage the pre-operating system applications:

- System Setup
- Boot Manager
- Dell Lifecycle Controller
- Preboot Execution Environment (PXE)

System Setup

By using the **System Setup** screen, you can configure the BIOS settings, iDRAC settings, and device settings of your system.

 **Note:** Help text for the selected field is displayed in the graphical browser by default. To view the help text in the text browser, press F1.

You can access system setup by using two methods:

- Standard graphical browser — The browser is enabled by default.
- Text browser — The browser is enabled by using Console Redirection.

Viewing System Setup

To view the **System Setup** screen, perform the following steps:

Procedure

1. Turn on, or restart your system.
2. Press F2 immediately after you see the following message:

```
F2 = System Setup
```

 **Note:** If your operating system begins to load before you press F2, wait for the system to finish booting, and then restart your system and try again.

System Setup details

The **System Setup Main Menu** screen details are explained as follows:

Option

Description

System BIOS

Enables you to configure BIOS settings.

iDRAC Settings

Enables you to configure iDRAC settings.

The iDRAC settings utility is an interface to set up and configure the iDRAC parameters by using UEFI (Unified Extensible Firmware Interface). You can enable or disable various iDRAC parameters by using the iDRAC settings utility. For more information about this utility, see *Integrated Dell Remote Access Controller User's Guide* at Dell.com/idracmanuals.

Device Settings

Enables you to configure device settings.

System BIOS

You can use the **System BIOS** screen to edit specific functions such as boot order, system password, setup password, set the RAID mode, and enable or disable USB ports.

Viewing System BIOS

To view the **System BIOS** screen, perform the following steps:

Procedure

1. Turn on, or restart your system.
2. Press F2 immediately after you see the following message:

```
F2 = System Setup
```

 **Note:** If your operating system begins to load before you press F2, wait for the system to finish booting, and then restart your system and try again.

3. On the **System Setup Main Menu** screen, click **System BIOS**.

System BIOS Settings details**About this task**

The **System BIOS Settings** screen details are explained as follows:

Option**Description****System Information**

Specifies information about the system such as the system model name, BIOS version, and Service Tag.

Memory Settings

Specifies information and options related to the installed memory.

Processor Settings

Specifies information and options related to the processor such as speed and cache size.

SATA Settings

Specifies options to enable or disable the integrated SATA controller and ports.

Boot Settings

Specifies options to specify the boot mode (BIOS or UEFI). Enables you to modify UEFI and BIOS boot settings.

Network Settings

Specifies options to change the network settings.

Integrated Devices

Specifies options to manage integrated device controllers and ports and specify related features and options.

Serial Communication

Specifies options to manage the serial ports and specify related features and options.

System Profile Settings

Specifies options to change the processor power management settings, memory frequency, and so on.

System Security

Specifies options to configure the system security settings, such as system password, setup password, Trusted Platform Module (TPM) security. It also manages the power and NMI buttons on the system.

Miscellaneous Settings

Specifies options to change the system date, time, and so on.

Boot Settings

You can use the **Boot Settings** screen to set the boot mode to either **BIOS** or **UEFI**. It also enables you to specify the boot order.

Viewing Boot Settings

To view the **Boot Settings** screen, perform the following steps:

Procedure

1. Turn on, or restart your system.
2. Press F2 immediately after you see the following message:

```
F2 = System Setup
```

 **Note:** If your operating system begins to load before you press F2, wait for the system to finish booting, and then restart your system and try again.

3. On the **System Setup Main Menu** screen, click **System BIOS**.
4. On the **System BIOS** screen, click **Boot Settings**.

Boot Settings details

About this task

The **Boot Settings** screen details are explained as follows:

Option Description

Boot Mode

Enables you to set the boot mode of the system.

 **CAUTION** Switching the boot mode may prevent the system from booting if the operating system is not installed in the same boot mode.

If the operating system supports UEFI, you can set this option to **UEFI**. Setting this field to **BIOS** allows compatibility with non-UEFI operating systems. This option is set to **BIOS** by default.

 **Note:** Setting this field to **UEFI** disables the **BIOS Boot Settings** menu. Setting this field to **BIOS** disables the **UEFI Boot Settings** menu.

Boot Sequence Retry

Enables or disables the Boot Sequence Retry feature. If this option is set to **Enabled** and the system fails to boot, the system reattempts the boot sequence after 30 seconds. This option is set to **Enabled** by default.

Hard-Disk Failover

Specifies the hard drive that is booted in the event of a hard drive failure. The devices are selected in the **Hard-Disk Drive Sequence** on the **Boot Option Setting** menu. When this option is set to **Disabled**, only the first hard drive in the list is attempted to boot. When this option is set to **Enabled**, all hard drives are attempted to boot in the order selected in the **Hard-Disk Drive Sequence**. This option is not enabled for UEFI Boot Mode.

Boot Option Settings

Configures the boot sequence and the boot devices.

BIOS Boot Settings

Enables or disables BIOS boot options.

 **Note:** This option is enabled only if the boot mode is BIOS.

UEFI Boot Settings

Enables or disables UEFI Boot options. The Boot options include **IPv4 PXE** and **IPv6 PXE**. This option is set to **IPv4** by default.

 **Note:** This option is enabled only if the boot mode is UEFI.

Choosing the system boot mode

System Setup enables you to specify one of the following boot modes for installing your operating system:

- BIOS boot mode (the default) is the standard BIOS-level boot interface.
- Unified Extensible Firmware Interface (UEFI) boot mode is an enhanced 64-bit boot interface. If you have configured your system to boot to UEFI mode, it replaces the system BIOS.

1. From the **System Setup Main Menu**, click **Boot Settings**, and select **Boot Mode**.

2. Select the boot mode you want the system to boot into.

 **CAUTION** Switching the boot mode may prevent the system from booting if the operating system is not installed in the same boot mode.

3. After the system boots in the specified boot mode, proceed to install your operating system from that mode.

 **Note:** Operating systems must be UEFI-compatible to be installed from the UEFI boot mode. DOS and 32-bit operating systems do not support UEFI and can only be installed from the BIOS boot mode.

 **Note:** For the latest information about supported operating systems, go to Dell.com/ossupport.

Changing the boot order

You may have to change the boot order if you want to boot from a USB key or an optical drive. The following instructions may vary if you have selected **BIOS** for **Boot Mode**.

Procedure

1. On the **System Setup Main Menu** screen, click **System BIOS > Boot Settings**.

2. Click **Boot Option Settings > Boot Sequence**.
3. Use the arrow keys to select a boot device, and use the plus (+) and minus (-) sign keys to move the device down or up in the order.
4. Click **Exit**, and then click **Yes** to save the settings on exit.

Network Settings

You can use the **Network Settings** screen to modify PXE device settings. The network settings option is available only in the UEFI mode.

Note: The BIOS does not control network settings in the BIOS mode. For the BIOS boot mode, the optional Boot ROM of the network controllers handles the network settings.

Viewing Network Settings

To view the **Network Settings** screen, perform the following steps:

Procedure

1. Turn on, or restart your system.
2. Press F2 immediately after you see the following message:

```
F2 = System Setup
```

Note: If your operating system begins to load before you press F2, wait for the system to finish booting, and then restart your system and try again.

3. On the **System Setup Main Menu** screen, click **System BIOS**.
4. On the **System BIOS** screen, click **Network Settings**.

Network Settings screen details

The **Network Settings** screen details are explained as follows:

About this task

Option Description

PXE Device n (n = 1 to 4)

Enables or disables the device. When enabled, a UEFI boot option is created for the device.

PXE Device n Settings(n = 1 to 4)

Enables you to control the configuration of the PXE device.

UEFI iSCSI Settings

You can use the iSCSI Settings screen to modify iSCSI device settings. The iSCSI Settings option is available only in the UEFI boot mode. BIOS does not control network settings in the BIOS boot mode. For the BIOS boot mode, the option ROM of the network controller handles the network settings.

Viewing UEFI iSCSI Settings

To view the **UEFI iSCSI Settings** screen, perform the following steps:

Procedure

1. Turn on, or restart your system.

2. Press F2 immediately after you see the following message:

```
F2 = System Setup
```

Note: If your operating system begins to load before you press F2, wait for the system to finish booting, and then restart your system and try again.

3. On the **System Setup Main Menu** screen, click **System BIOS**.
4. On the **System BIOS** screen, click **Network Settings**.
5. On the **Network Settings** screen, click **UEFI iSCSI Settings**.

UEFI iSCSI Settings details

The **UEFI iSCSI Settings** screen details are explained as follows:

**Option
Description**

ISCSI Initiator Name

Specifies the name of the iSCSI initiator (iqn format).

ISCSI Device n (n = 1 to 4)

Enables or disables the iSCSI device. When disabled, a UEFI boot option is created for the iSCSI device automatically.

System Security

You can use the **System Security** screen to perform specific functions such as setting the system password, setup password and disabling the power button.

Viewing System Security

To view the **System Security** screen, perform the following steps:

Procedure

1. Turn on, or restart your system.
2. Press F2 immediately after you see the following message:

```
F2 = System Setup
```

Note: If your operating system begins to load before you press F2, wait for the system to finish booting, and then restart your system and try again.

3. On the **System Setup Main Menu** screen, click **System BIOS**.
4. On the **System BIOS** screen, click **System Security**.

System Security Settings details

About this task

The **System Security Settings** screen details are explained as follows:

**Option
Description**

Intel AES-NI

Improves the speed of applications by performing encryption and decryption by using the Advanced Encryption Standard Instruction Set (AES-NI). This option is set to **Enabled** by default.

System Password

Sets the system password. This option is set to **Enabled** by default and is read-only if the password jumper is not installed in the system.

Setup Password

Sets the setup password. This option is read-only if the password jumper is not installed in the system.

Password Status

Locks the system password. This option is set to **Unlocked** by default.

TPM Security

 **Note:** The TPM menu is available only when the TPM module is installed.

Enables you to control the reporting mode of the TPM. The **TPM Security** option is set to **Off** by default. You can only modify the TPM Status, TPM Activation, and Intel TXT fields if the **TPM Status** field is set to either **On with Pre-boot Measurements** or **On without Pre-boot Measurements**.

TPM Information

Changes the operational state of the TPM. This option is set to **No Change** by default.

TPM Status

Specifies the TPM status.

TPM Command

 **CAUTION** Clearing the TPM results in the loss of all keys in the TPM. The loss of TPM keys may affect booting to the operating system.

Clears all the contents of the TPM. The **TPM Clear** option is set to **No** by default.

Intel TXT

Enables or disables the Intel Trusted Execution Technology (TXT) option. To enable the **Intel TXT** option, virtualization technology and TPM Security must be enabled with Pre-boot measurements. This option is set to **Off** by default.

Power Button

Enables or disables the power button on the front of the system. This option is set to **Enabled** by default.

NMI Button

Enables or disables the NMI button on the front of the system. This option is set to **Disabled** by default.

AC Power Recovery

Sets how the system behaves after AC power is restored to the system. This option is set to **Last** by default.

AC Power Recovery Delay

Sets the time delay for the system to power up after AC power is restored to the system. This option is set to **Immediate** by default.

User Defined Delay (60s to 240s)

Sets the **User Defined Delay** option when the **User Defined** option for **AC Power Recovery Delay** is selected.

UEFI Variable Access

Provides varying degrees of securing UEFI variables. When set to **Standard** (the default), UEFI variables are accessible in the operating system per the UEFI specification. When set to **Controlled**, selected UEFI variables are protected in the environment and new UEFI boot entries are forced to be at the end of the current boot order.

Secure Boot

Enables Secure Boot, where the BIOS authenticates each pre-boot image by using the certificates in the Secure Boot Policy. Secure Boot is disabled by default.

Secure Boot Policy

When Secure Boot policy is set to **Standard**, the BIOS uses the system manufacturer's key and certificates to authenticate pre-boot images. When Secure Boot policy is set to **Custom**, the BIOS uses the user-defined key and certificates. Secure Boot policy is set to **Standard** by default.

Secure Boot Policy Summary

Specifies the list of certificates and hashes that secure boot uses to authenticate images.

Secure Boot Custom Policy Settings

Secure Boot Custom Policy Settings is displayed only when **Secure Boot Policy** is set to **Custom**.

Viewing Secure Boot Custom Policy Settings

To view the **Secure Boot Custom Policy Settings** screen, perform the following steps:

Procedure

1. Turn on, or restart your system.
2. Press F2 immediately after you see the following message:

```
F2 = System Setup
```

 **Note:** If your operating system begins to load before you press F2, wait for the system to finish booting, and then restart your system and try again.

3. On the **System Setup Main Menu** screen, click **System BIOS**.
4. On the **System BIOS** screen, click **System Security**.
5. On the **System Security** screen, click **Secure Boot Custom Policy Settings**.

Secure Boot Custom Policy Settings details

The **Secure Boot Custom Policy Settings** screen details are explained as follows:

Option
Description

Platform Key

Imports, exports, deletes, or restores the platform key (PK).

Key Exchange Key Database

Enables you to import, export, delete, or restore entries in the Key Exchange Key (KEK) Database.

Authorized Signature Database

Imports, exports, deletes, or restores entries in the Authorized Signature Database (db).

Forbidden Signature Database

Imports, exports, deletes, or restores entries in the Forbidden Signature Database (dbx).

Creating a system and setup password

Before you begin

Ensure that the password jumper is enabled. The password jumper enables or disables the system password and setup password features. For more information, see the System board jumper settings section.

 **Note:** If the password jumper setting is disabled, the existing system password and setup password are deleted and you need not provide the system password to boot the system.

Procedure

1. To enter System Setup, press F2 immediately after turning on or rebooting your system.
2. On the **System Setup Main Menu** screen, click **System BIOS > System Security**.
3. On the **System Security** screen, verify that **Password Status** is set to **Unlocked**.
4. In the **System Password** field, type your system password, and press Enter or Tab.

Use the following guidelines to assign the system password:

- A password can have up to 32 characters.
- The password can contain the numbers 0 through 9.
- Only the following special characters are allowed: space, ("), (+), (,), (-), (.), (/), (;), ([, (\), (]), (`).

A message prompts you to reenter the system password.

5. Reenter the system password, and click **OK**.
6. In the **Setup Password** field, type your setup password and press Enter or Tab.

A message prompts you to reenter the setup password.

7. Reenter the setup password, and click **OK**.
8. Press Esc to return to the System BIOS screen. Press Esc again.

A message prompts you to save the changes.

 **Note:** Password protection does not take effect until the system reboots.

Using your system password to secure your system

If you have assigned a setup password, the system accepts your setup password as an alternate system password.

Procedure

1. Turn on or reboot your system.
2. Type the system password and press Enter.

After you finish

When **Password Status** is set to **Locked**, type the system password and press Enter when prompted at reboot.

Note: If an incorrect system password is typed, the system displays a message and prompts you to reenter your password. You have three attempts to type the correct password. After the third unsuccessful attempt, the system displays an error message that the system has stopped functioning and must be turned off. Even after you turn off and restart the system, the error message is displayed until the correct password is entered.

Deleting or changing system and setup password

Before you begin

Note: You cannot delete or change an existing system or setup password if the **Password Status** is set to **Locked**.

Procedure

1. To enter System Setup, press F2 immediately after turning on or restarting your system.
2. On the **System Setup Main Menu** screen, click **System BIOS > System Security**.
3. On the **System Security** screen, ensure that **Password Status** is set to **Unlocked**.
4. In the **System Password** field, alter or delete the existing system password, and then press Enter or Tab.
5. In the **Setup Password** field, alter or delete the existing setup password, and then press Enter or Tab.

If you change the system and setup password, a message prompts you to reenter the new password. If you delete the system and setup password, a message prompts you to confirm the deletion.

6. Press Esc to return to the **System BIOS** screen. Press Esc again, and a message prompts you to save the changes.

Operating with a setup password enabled

If **Setup Password** is set to **Enabled**, type the correct setup password before modifying the system setup options.

If you do not type the correct password in three attempts, the system displays the following message:

```
Invalid Password! Number of unsuccessful password attempts: <x> System
Halted! Must power down.
```

Even after you turn off and restart the system, the error message is displayed until the correct password is typed. The following options are exceptions:

- If **System Password** is not set to **Enabled** and is not locked through the **Password Status** option, you can assign a system password. For more information, see the System Security Settings screen section.
- You cannot disable or change an existing system password.

Note: You can use the password status option with the setup password option to protect the system password from unauthorized changes.

System Information

You can use the **System Information** screen to view system properties such as Service Tag, system model name, and the BIOS version.

Viewing System Information

To view the **System Information** screen, perform the following steps:

Procedure

1. Turn on, or restart your system.
2. Press F2 immediately after you see the following message:

```
F2 = System Setup
```

 **Note:** If your operating system begins to load before you press F2, wait for the system to finish booting, and then restart your system and try again.

3. On the **System Setup Main Menu** screen, click **System BIOS**.
4. On the **System BIOS** screen, click **System Information**.

System Information details

About this task

The **System Information** screen details are explained as follows:

Option	Description
--------	-------------

	System Model Name
--	--------------------------

	Specifies the system model name.
--	----------------------------------

	System BIOS Version
--	----------------------------

	Specifies the BIOS version installed on the system.
--	---

	System Management Engine Version
--	---

	Specifies the current version of the Management Engine firmware.
--	--

	System Service Tag
--	---------------------------

	Specifies the system Service Tag.
--	-----------------------------------

	System Manufacturer
--	----------------------------

	Specifies the name of the system manufacturer.
--	--

	System Manufacturer Contact Information
--	--

	Specifies the contact information of the system manufacturer.
--	---

	System CPLD Version
--	----------------------------

	Specifies the current version of the system complex programmable logic device (CPLD) firmware.
--	--

	UEFI Compliance Version
--	--------------------------------

	Specifies the UEFI compliance level of the system firmware.
--	---

Memory Settings

You can use the **Memory Settings** screen to view all the memory settings and enable or disable specific memory functions, such as system memory testing and node interleaving.

Viewing Memory Settings

To view the **Memory Settings** screen, perform the following steps:

Procedure

1. Turn on, or restart your system.
2. Press F2 immediately after you see the following message:

```
F2 = System Setup
```

Note: If your operating system begins to load before you press F2, wait for the system to finish booting, and then restart your system and try again.

3. On the **System Setup Main Menu** screen, click **System BIOS**.
4. On the **System BIOS** screen, click **Memory Settings**.

Memory Settings details

About this task

The **Memory Settings** screen details are explained as follows:

Option Description

System Memory Size

Specifies the memory size in the system.

System Memory Type

Specifies the type of memory installed in the system.

System Memory Speed

Specifies the system memory speed.

System Memory Voltage

Specifies the system memory voltage.

Video Memory

Specifies the amount of video memory.

System Memory Testing

Specifies whether the system memory tests are run during system boot. Options are **Enabled** and **Disabled**. This option is set to **Disabled** by default.

Memory Operating Mode

Specifies the memory operating mode. The options available are **Optimizer Mode**, **Advanced ECC Mode**, **Mirror Mode**, **Spare Mode**, **Spare with Advanced ECC Mode**, **Dell Fault Resilient Mode** and **Dell NUMA Fault Resilient Mode**. This option is set to **Optimizer Mode** by default.

Note: The **Memory Operating Mode** option can have different default and available options based on the memory configuration of your system.

Note: The **Dell Fault Resilient Mode** option establishes an area of memory that is fault resilient. This mode can be used by an operating system that supports the feature to load critical applications or enables the operating system kernel to maximize system availability.

Node Interleaving

Specifies if Non-Uniform Memory architecture (NUMA) is supported. If this field is set to **Enabled**, memory interleaving is supported if a symmetric memory configuration is installed. If the field is set to **Disabled**, the system supports NUMA (asymmetric) memory configurations. This option is set to **Disabled** by default.

Snoop Mode

Specifies the Snoop Mode options. The Snoop Mode options available are **Home Snoop**, **Early Snoop**, and **Cluster on Die**. This option is set to **Early Snoop** by default. This field is available only when the **Node Interleaving** is set to **Disabled**.

Processor Settings

You can use the **Processor Settings** screen to view the processor settings, and perform specific functions such as enabling virtualization technology, hardware prefetcher, and logical processor idling.

Viewing Processor Settings

To view the **Processor Settings** screen, perform the following steps:

Procedure

1. Turn on, or restart your system.
2. Press F2 immediately after you see the following message:

```
F2 = System Setup
```

Note: If your operating system begins to load before you press F2, wait for the system to finish booting, and then restart your system and try again.

3. On the **System Setup Main Menu** screen, click **System BIOS**.
4. On the **System BIOS** screen, click **Processor Settings**.

Processor Settings details

About this task

The **Processor Settings** screen details are explained as follows:

Option	Description
--------	-------------

Logical Processor

Enables or disables the logical processors and displays the number of logical processors. If this option is set to **Enabled**, the BIOS displays all the logical processors. If this option is set to **Disabled**, the BIOS displays only one logical processor per core. This option is set to **Enabled** by default.

QPI Speed

Enables you to control QuickPath Interconnect data rate settings.

Alternate RTID (Requestor Transaction ID) Setting

Modifies Requestor Transaction IDs, which are QPI resources. This option is set to **Disabled** by default.

 **Note:** Enabling this option may negatively impact the overall system performance.

Virtualization Technology

Enables or disables the additional hardware capabilities provided for virtualization. This option is set to **Enabled** by default.

Address Translation Service (ATS)

Defines the Address Translation Cache (ATC) for devices to cache the DMA transactions. This option provides an interface between CPU and DMA Memory Management to a chipset's Address Translation and Protection Table to translate DMA addresses to host addresses. This option is set to **Enabled** by default.

Adjacent Cache Line Prefetch

Optimizes the system for applications that need high utilization of sequential memory access. This option is set to **Enabled** by default. You can disable this option for applications that need high utilization of random memory access.

Hardware Prefetcher

Enables or disables the hardware prefetcher. This option is set to **Enabled** by default.

DCU Streamer Prefetcher

Enables or disables the Data Cache Unit (DCU) streamer prefetcher. This option is set to **Enabled** by default.

DCU IP Prefetcher

Enables or disables the Data Cache Unit (DCU) IP prefetcher. This option is set to **Enabled** by default.

Execute Disable

Enables you to run the disable memory protection technology. This option is set to **Enabled** by default.

Logical Processor Idling

Enables you to improve the energy efficiency of a system. It uses the operating system core parking algorithm and parks some of the logical processors in the system which in turn allows the corresponding processor cores to transition into a lower power idle state. This option can only be enabled if the operating system supports it. It is set to **Disabled** by default.

Configurable TDP

Enables you to reconfigure the processor Thermal Design Power (TDP) levels during POST based on the power and thermal delivery capabilities of the system. TDP verifies the maximum heat the cooling system is needed to dissipate. This option is set to **Nominal** by default.

 **Note:** This option is only available on certain stock keeping units (SKUs) of the processors.

X2Apic Mode

Enables or disables the X2Apic mode.

Dell Controlled Turbo

Controls the turbo engagement. Enable this option only when **System Profile** is set to **Performance**.

 **Note:** Depending on the number of installed CPUs, there may be up to four processor listings.

Number of Cores per Processor

Controls the number of enabled cores in each processor. This option is set to **All** by default.

Processor 64-bit Support

Specifies if the processor(s) support 64-bit extensions.

Processor Core Speed

Specifies the maximum core frequency of the processor.

Processor 1

 **Note:** Depending on the number of CPUs, there may be up to four processors listed.

The following settings are displayed for each processor installed in the system:

Option Description

Family-Model-Stepping

Specifies the family, model, and stepping of the processor as defined by Intel.

Brand

Specifies the brand name.

Level 2 Cache

Specifies the total L2 cache.

Level 3 Cache

Specifies the total L3 cache.

Number of Cores

Specifies the number of cores per processor.

SATA Settings

You can use the **SATA Settings** screen to view the SATA settings of SATA devices and enable RAID on your system.

Viewing SATA Settings

To view the **SATA Settings** screen, perform the following steps:

Procedure

1. Turn on, or restart your system.
2. Press F2 immediately after you see the following message:

```
F2 = System Setup
```

 **Note:** If your operating system begins to load before you press F2, wait for the system to finish booting, and then restart your system and try again.

3. On the **System Setup Main Menu** screen, click **System BIOS**.

4. On the **System BIOS** screen, click **SATA Settings**.

SATA Settings details

About this task

The **SATA Settings** screen details are explained as follows:

Option Description

Embedded SATA

Enables the embedded SATA option to be set to **Off**, **ATA**, **AHCI**, or **RAID** modes. This option is set to **AHCI** by default.

Security Freeze Lock

Sends Security Freeze Lock command to the Embedded SATA drives during POST. This option is applicable only for **ATA** and **AHCI** modes.

Write Cache

Enables or disables the command for Embedded SATA drives during POST.

Port A

Sets the drive type of the selected device. For **Embedded SATA settings** in **ATA** mode, set this field to **Auto** to enable BIOS support. Set it to **OFF** to turn off BIOS support. For **AHCI** or **RAID** mode, BIOS support is always enabled.

Option Description

Model

Specifies the drive model of the selected device.

Drive Type

Specifies the type of drive attached to the SATA port.

Capacity

Specifies the total capacity of the hard drive. This field is undefined for removable media devices such as optical drives.

Port B

Sets the drive type of the selected device. For **Embedded SATA settings** in **ATA** mode, set this field to **Auto** to enable BIOS support. Set it to **OFF** to turn off BIOS support. For **AHCI** or **RAID** mode, BIOS support is always enabled.

Option Description

Model

Specifies the drive model of the selected device.

Drive Type

Specifies the type of drive attached to the SATA port.

Capacity

Specifies the total capacity of the hard drive. This field is undefined for removable media devices such as optical drives.

Port C

Sets the drive type of the selected device. For **Embedded SATA settings** in **ATA** mode, set this field to **Auto** to enable BIOS support. Set it to **OFF** to turn off BIOS support. For **AHCI** or **RAID** mode, BIOS support is always enabled.

Option
Description

Model

Specifies the drive model of the selected device.

Drive Type

Specifies the type of drive attached to the SATA port.

Capacity

Specifies the total capacity of the hard drive. This field is undefined for removable media devices such as optical drives.

Port D

Sets the drive type of the selected device. For **Embedded SATA settings** in **ATA** mode, set this field to **Auto** to enable BIOS support. Set it to **OFF** to turn off BIOS support. For **AHCI** or **RAID** mode, BIOS support is always enabled.

Option
Description

Model

Specifies the drive model of the selected device.

Drive Type

Specifies the type of drive attached to the SATA port.

Capacity

Specifies the total capacity of the hard drive. This field is undefined for removable media devices such as optical drives.

Port E

Sets the drive type of the selected device. For **Embedded SATA settings** in **ATA** mode, set this field to **Auto** to enable BIOS support. Set it to **OFF** to turn off BIOS support. For **AHCI** or **RAID** mode, BIOS support is always enabled.

Option
Description

Model

Specifies the drive model of the selected device.

Drive Type

Specifies the type of drive attached to the SATA port.

Capacity

Specifies the total capacity of the hard drive. This field is undefined for removable media devices such as optical drives.

Port F

Sets the drive type of the selected device. For **Embedded SATA settings** in **ATA** mode, set this field to **Auto** to enable BIOS support. Set it to **OFF** to turn off BIOS support. For **AHCI** or **RAID** mode, BIOS support is always enabled.

**Option
Description**

Model

Specifies the drive model of the selected device.

Drive Type

Specifies the type of drive attached to the SATA port.

Capacity

Specifies the total capacity of the hard drive. This field is undefined for removable media devices such as optical drives.

Port G

Sets the drive type of the selected device. For **Embedded SATA settings** in **ATA** mode, set this field to **Auto** to enable BIOS support. Set it to **OFF** to turn off BIOS support. For **AHCI** or **RAID** mode, BIOS support is always enabled.

**Option
Description**

Model

Specifies the drive model of the selected device.

Drive Type

Specifies the type of drive attached to the SATA port.

Capacity

Specifies the total capacity of the hard drive. This field is undefined for removable media devices such as optical drives.

Port H

Sets the drive type of the selected device. For **Embedded SATA settings** in **ATA** mode, set this field to **Auto** to enable BIOS support. Set it to **OFF** to turn off BIOS support. For **AHCI** or **RAID** mode, BIOS support is always enabled.

**Option
Description**

Model

Specifies the drive model of the selected device.

Drive Type

Specifies the type of drive attached to the SATA port.

Capacity

Specifies the total capacity of the hard drive. This field is undefined for removable media devices such as optical drives.

Port I

Sets the drive type of the selected device. For **Embedded SATA settings** in **ATA** mode, set this field to **Auto** to enable BIOS support. Set it to **OFF** to turn off BIOS support. For **AHCI** or **RAID** mode, BIOS support is always enabled.

Option
Description

Model

Specifies the drive model of the selected device.

Drive Type

Specifies the type of drive attached to the SATA port.

Capacity

Specifies the total capacity of the hard drive. This field is undefined for removable media devices such as optical drives.

Port J

Sets the drive type of the selected device. For **Embedded SATA settings** in **ATA** mode, set this field to **Auto** to enable BIOS support. Set it to **OFF** to turn off BIOS support. For **AHCI** or **RAID** mode, BIOS support is always enabled.

Option
Description

Model

Specifies the drive model of the selected device.

Drive Type

Specifies the type of drive attached to the SATA port.

Capacity

Specifies the total capacity of the hard drive. This field is undefined for removable media devices such as optical drives.

Integrated Devices

You can use the **Integrated Devices** screen to view and configure the settings of all integrated devices including the video controller, integrated RAID controller, and the USB ports.

Viewing Integrated Devices

To view the **Integrated Devices** screen, perform the following steps:

Procedure

1. Turn on, or restart your system.
2. Press F2 immediately after you see the following message:

```
F2 = System Setup
```

 **Note:** If your operating system begins to load before you press F2, wait for the system to finish booting, and then restart your system and try again.

3. On the **System Setup Main Menu** screen, click **System BIOS**.

4. On the **System BIOS** screen, click **Integrated Devices**.

Integrated Devices details

About this task

The **Integrated Devices** screen details are explained as follows:

Option Description

USB 3.0 Setting

Enables or disables the USB 3.0 support. Enable this option only if your operating system supports USB 3.0. If you disable this option, devices operate at USB 2.0 speed. USB 3.0 is enabled by default.

User Accessible USB Ports

Enables or disables the USB ports. Selecting **Only Back Ports On** disables the front USB ports, selecting **All Ports Off** disables all USB ports. The USB keyboard and mouse operate during boot process in certain operating systems. After the boot process is complete, the USB keyboard and mouse do not work if the ports are disabled.

 **Note:** Selecting **Only Back Ports On** and **All Ports Off** disables the USB management port and also restricts access to iDRAC features.

Internal USB Port

Enables or disables the internal USB port. This option is set to **Enabled** by default.

Integrated RAID Controller

Enables or disables the integrated RAID controller. This option is set to **Enabled** by default.

Integrated Network Card 1

Enables or disables the integrated network card.

I/OAT DMA Engine

Enables or disables the I/OAT option. Enable only if the hardware and software support the feature.

Embedded Video Controller

Enables or disables the **Embedded Video Controller** option. This option is set to **Enabled** by default.

Current State of Embedded Video Controller

Displays the current state of the embedded video controller. The **Current State of Embedded Video Controller** option is a read-only field. If the Embedded Video Controller is the only display capability in the system (that is, no add-in graphics card is installed), then the Embedded Video Controller is automatically used as the primary display even if the **Embedded Video Controller** setting is set to **Disabled**.

SR-IOV Global Enable

Enables or disables the BIOS configuration of Single Root I/O Virtualization (SR-IOV) devices. This option is set to **Disabled** by default.

OS Watchdog Timer

If your system stops responding, this watchdog timer aids in the recovery of your operating system. When this option is set to **Enabled**, the operating system initializes the timer. When this option is set to **Disabled** (the default), the timer does not have any effect on the system.

Memory Mapped I/O above 4 GB

Enables or disables the support for PCIe devices that need large amounts of memory. This option is set to **Enabled** by default.

Slot Disablement

Enables or disables the available PCIe slots on your system. The slot disablement feature controls the configuration of PCIe cards installed in the specified slot. Slots must be disabled only when the installed peripheral card prevents booting into the operating system or causes delays in system startup. If the slot is disabled, both the Option ROM and UEFI drivers are disabled.

Serial Communication

You can use the **Serial Communication** screen to view the properties of the serial communication port.

Viewing Serial Communication

To view the **Serial Communication** screen, perform the following steps:

Procedure

1. Turn on, or restart your system.
2. Press F2 immediately after you see the following message:

```
F2 = System Setup
```

 **Note:** If your operating system begins to load before you press F2, wait for the system to finish booting, and then restart your system and try again.

3. On the **System Setup Main Menu** screen, click **System BIOS**.
4. On the **System BIOS** screen, click **Serial Communication**.

Serial Communication details

About this task

The **Serial Communication** screen details are explained as follows:

Option Description

Serial Communication

Selects serial communication devices (Serial Device 1 and Serial Device 2) in BIOS. BIOS console redirection can also be enabled and the port address can be specified. This option is set to **Auto** by default.

Serial Port Address

Enables you to set the port address for serial devices. This option is set to **Serial Device 1=COM2, Serial Device 2=COM1** by default.

 **Note:** You can use only Serial Device 2 for the Serial Over LAN (SOL) feature. To use console redirection by SOL, configure the same port address for console redirection and the serial device.

 **Note:** Every time the system boots, the BIOS syncs the serial MUX setting saved in iDRAC. The serial MUX setting can independently be changed in iDRAC. Loading the BIOS

default settings from within the BIOS setup utility may not always revert the serial MUX setting to the default setting of Serial Device 1.

External Serial Connector

Enables you to associate the External Serial Connector to Serial Device 1, Serial Device 2, or the Remote Access Device by using this option.

Note: Only Serial Device 2 can be used for Serial Over LAN (SOL). To use console redirection by SOL, configure the same port address for console redirection and the serial device.

Note: Every time the system boots, the BIOS syncs the serial MUX setting saved in iDRAC. The serial MUX setting can independently be changed in iDRAC. Loading the BIOS default settings from within the BIOS setup utility may not always revert this setting to the default setting of Serial Device 1.

Failsafe Baud Rate

Specifies the failsafe baud rate for console redirection. The BIOS attempts to determine the baud rate automatically. This failsafe baud rate is used only if the attempt fails, and the value must not be changed. This option is set to 115200 by default.

Remote Terminal Type

Sets the remote console terminal type. This option is set to $\nabla \nabla$ 100/ $\nabla \nabla$ 220 by default.

Redirection After Boot

Enables or disables the BIOS console redirection when the operating system is loaded. This option is set to **Enabled** by default.

System Profile Settings

You can use the **System Profile Settings** screen to enable specific system performance settings such as power management.

Viewing System Profile Settings

To view the **System Profile Settings** screen, perform the following steps:

Procedure

1. Turn on, or restart your system.
2. Press F2 immediately after you see the following message:

```
F2 = System Setup
```

Note: If your operating system begins to load before you press F2, wait for the system to finish booting, and then restart your system and try again.

3. On the **System Setup Main Menu** screen, click **System BIOS**.
4. On the **System BIOS** screen, click **System Profile Settings**.

System Profile Settings details

About this task

The **System Profile Settings** screen details are explained as follows:

Option
Description

System Profile

Sets the system profile. If you set the **System Profile** option to a mode other than **Custom**, the BIOS automatically sets the rest of the options. You can only change the rest of the options if the mode is set to **Custom**. This option is set to **Performance Per Watt Optimized (DAPC)** by default. DAPC is Dell Active Power Controller.

 **Note:** All the parameters on the system profile setting screen are available only when the **System Profile** option is set to **Custom**.

CPU Power Management

Sets the CPU power management. This option is set to **System DBPM (DAPC)** by default. DBPM is Demand-Based Power Management.

Memory Frequency

Sets the speed of the system memory. You can select **Maximum Performance**, **Maximum Reliability**, or a specific speed.

Turbo Boost

Enables or disables the processor to operate in the turbo boost mode. This option is set to **Enabled** by default.

Energy Efficient Turbo

Enables or disables the **Energy Efficient Turbo** option. Energy Efficient Turbo (EET) is a mode of operation where a processor's core frequency is adjusted to be within the turbo range based on workload.

C1E

Enables or disables the processor to switch to a minimum performance state when it is idle. This option is set to **Enabled** by default.

C States

Enables or disables the processor to operate in all available power states. This option is set to **Enabled** by default.

Collaborative CPU Performance Control

Enables or disables the CPU power management option. When set to **Enabled**, the CPU power management is controlled by the OS DBPM and the System DBPM (DAPC). This option is set to **Disabled** by default.

Memory Patrol Scrub

Sets the memory patrol scrub frequency. This option is set to **Standard** by default.

Memory Refresh Rate

Sets the memory refresh rate to either 1x or 2x. This option is set to **1x** by default.

Uncore Frequency

Enables you to select the **Processor Uncore Frequency** option. Dynamic mode enables the processor to optimize power resources across the cores and uncore during runtime. The optimization of the uncore frequency to either save power or optimize performance is influenced by the setting of the **Energy Efficiency Policy** option.

Energy Efficient Policy

Enables you to select the **Energy Efficient Policy** option.

The CPU uses the setting to manipulate the internal behavior of the processor and determines whether to target higher performance or better power savings.

Number of Turbo Boost Enabled Cores for Processor 1

Note: If there are two processors installed in the system, you see an entry for **Number of Turbo Boost Enabled Cores for Processor 2**.

Controls the number of turbo boost enabled cores for processor 1. The maximum number of cores is enabled by default.

Monitor/Mwait

Enables the Monitor/Mwait instructions in the processor. This option is set to **Enabled** for all system profiles, except **Custom** by default.

Note: This option can be disabled only if the **C States** option in the **Custom** mode is set to **disabled**.

Note: When **C States** is set to **Enabled** in the **Custom** mode, changing the Monitor/Mwait setting does not impact the system power or performance.

Miscellaneous Settings

You can use the **Miscellaneous Settings** screen to perform specific functions such as updating the asset tag and changing the system date and time.

Viewing Miscellaneous Settings

To view the **Miscellaneous Settings** screen, perform the following steps:

Procedure

1. Turn on, or restart your system.
2. Press F2 immediately after you see the following message:

```
F2 = System Setup
```

Note: If your operating system begins to load before you press F2, wait for the system to finish booting, and then restart your system and try again.

3. On the **System Setup Main Menu** screen, click **System BIOS**.
4. On the **System BIOS** screen, click **Miscellaneous Settings**.

Miscellaneous Settings details

About this task

The **Miscellaneous Settings** screen details are explained as follows:

Option Description

System Time

Enables you to set the time on the system.

System Date

Enables you to set the date on the system.

Asset Tag

Specifies the asset tag and enables you to modify it for security and tracking purposes.

Keyboard NumLock

Enables you to set whether the system boots with the NumLock enabled or disabled. This option is set to **On** by default.

 **Note:** This option does not apply to 84-key keyboards.

F1/F2 Prompt on Error

Enables or disables the F1/F2 prompt on error. This option is set to **Enabled** by default. The F1/F2 prompt also includes keyboard errors.

Load Legacy Video Option ROM

Enables you to determine whether the system BIOS loads the legacy video (INT 10H) option ROM from the video controller. Selecting **Enabled** in the operating system does not support UEFI video output standards. This field is available only for UEFI boot mode. You cannot set the option to **Enabled** if **UEFI Secure Boot** mode is enabled.

In-System Characterization

Enables or disables **In-System Characterization**. This option is set to **Disabled** by default. The two other options are **Enabled** and **Enabled - No Reboot**.

 **Note:** The default setting for **In-System Characterization** is subject to change in future BIOS releases.

When enabled, In-System Characterization (ISC) executes during POST upon detecting relevant change(s) in system configuration to optimize system power and performance. ISC takes about 20 seconds to execute, and system reset is needed for ISC results to be applied. The **Enabled - No Reboot** option executes ISC and continues without applying ISC results until the next time system reset occurs. The **Enabled** option executes ISC and forces an immediate system reset so that ISC results can be applied. It takes the system longer to be ready due to the forced system reset. When disabled, ISC does not execute.

iDRAC Settings utility

The iDRAC settings utility is an interface to set up and configure the iDRAC parameters by using UEFI. You can enable or disable various iDRAC parameters by using the iDRAC settings utility.

 **Note:** Accessing some of the features on the iDRAC settings utility needs the iDRAC Enterprise License upgrade.

For more information about using iDRAC, see *Dell Integrated Dell Remote Access Controller User's Guide* at Dell.com/idracmanuals.

Entering the iDRAC Settings utility

Procedure

1. Turn on or restart the managed system.
2. Press F2 during Power-on Self-test (POST).
3. On the **System Setup Main Menu** page, click **iDRAC Settings**.

The **iDRAC Settings** screen is displayed.

Changing the thermal settings

The iDRAC settings utility enables you to select and customize the thermal control settings for your system.

1. Click **iDRAC Settings > Thermal**.
2. Under **SYSTEM THERMAL PROFILE > Thermal Profile**, select one of the following options:
 - Default Thermal Profile Settings
 - Maximum Performance (Performance Optimized)
 - Minimum Power (Performance per Watt Optimized)
3. Under **USER COOLING OPTIONS**, set the **Fan Speed Offset**, **Minimum Fan Speed**, and **Custom Minimum Fan Speed**.
4. Click **Back > Finish > Yes**.

Device Settings

Device Settings enables you to configure device parameters.

Dell Lifecycle Controller

Dell Lifecycle Controller (LC) provides advanced embedded systems management capabilities including system deployment, configuration, update, maintenance, and diagnosis. LC is delivered as part of the iDRAC out-of-band solution and Dell system embedded Unified Extensible Firmware Interface (UEFI) applications.

Embedded system management

The Dell Lifecycle Controller provides advanced embedded systems management throughout the system's lifecycle. The Dell Lifecycle Controller can be started during the boot sequence and can function independently of the operating system.

 **Note:** Certain platform configurations may not support the full set of features provided by the Dell Lifecycle Controller.

For more information about setting up the Dell Lifecycle Controller, configuring hardware and firmware, and deploying the operating system, see the Dell Lifecycle Controller documentation at Dell.com/idracmanuals.

Boot Manager

The **Boot Manager** screen enables you to select boot options and diagnostic utilities.

Viewing Boot Manager

To enter **Boot Manager**:

Procedure

1. Turn on, or restart your system.
2. Press F11 when you see the following message:

```
F11 = Boot Manager
```

If your operating system begins to load before you press F11, allow the system to complete the booting, and then restart your system and try again.

Boot Manager main menu

Menu item

Description

Continue Normal Boot

The system attempts to boot to devices starting with the first item in the boot order. If the boot attempt fails, the system continues with the next item in the boot order until the boot is successful or no more boot options are found.

One-shot Boot Menu

Enables you to access boot menu, where you can select a one-time boot device to boot from.

Launch System Setup

Enables you to access System Setup.

Launch Lifecycle Controller

Exits the Boot Manager and invokes the Dell Lifecycle Controller program.

System Utilities

Enables you to launch System Utilities menu such as System Diagnostics and UEFI shell.

One-shot BIOS boot menu

One-shot BIOS boot menu enables you to select a boot device to boot from.

System Utilities

System Utilities contains the following utilities that can be launched:

- Launch Diagnostics
- BIOS Update File Explorer
- Reboot System

PXE boot







The Preboot Execution Environment (PXE) is an industry standard client or interface that allows networked computers that are not yet loaded with an operating system to be configured and booted remotely by an administrator.

CHAPTER 6

Installing and removing system components

- Safety instructions..... 84
- Before working inside your system..... 84
- After working inside your system..... 84
- Recommended tools..... 85
- Front bezel (optional)..... 85
- System cover..... 87
- Inside the system..... 89
- Cooling shroud..... 92
- System memory..... 94
- Hard drives..... 105
- Optical drive (optional)..... 118
- Cooling fans..... 123
- Internal USB memory key (optional)..... 125
- Expansion cards and expansion card riser..... 127
- iDRAC port card (optional)..... 132
- SD vFlash card (optional)..... 136
- Internal dual SD module (optional)..... 137
- Integrated storage controller card..... 141
- Processors and heat sinks..... 144
- Power supply units..... 153
- System battery..... 160
- Hard-drive backplane..... 162
- Control panel..... 171
- Power interposer board..... 181
- System board..... 183
- Trusted Platform Module..... 188

Safety instructions

-  **Note:** Whenever you need to lift the system, get others to assist you. To avoid injury, do not attempt to lift the system by yourself.
-  **WARNING** Opening or removing the system cover while the system is powered on may expose you to a risk of electric shock.
-  **CAUTION** Do not operate the system without the cover for a duration exceeding five minutes.
-  **CAUTION** Many repairs may only be done by a certified service technician. You should only perform troubleshooting and simple repairs as authorized in your product documentation, or as directed by the online or telephone service and support team. Damage due to servicing that is not authorized by Dell is not covered by your warranty. Read and follow the safety instructions that are shipped with your product.
-  **Note:** Dell recommends that you always use a static mat and static strap while working on components inside the system.
-  **Note:** To ensure proper operation and cooling, all bays in the system and system fans must be populated always with either a component or with a blank.

Before working inside your system

Before you begin

Follow the safety guidelines listed in the Safety instructions section.

Procedure

1. Turn off the system, including any attached peripherals.
2. Disconnect the system from the electrical outlet and disconnect the peripherals.
3. If installed, remove the front bezel.
4. If applicable, remove the system from the rack.

For more information, see the *Rack Installation* placemat at Dell.com/poweredgemanuals.

5. Remove the system cover.

After working inside your system

Before you begin

Follow the safety guidelines listed in the Safety instructions section.

Procedure

1. Install the system cover.
2. If applicable, install the system into the rack.
For more information, see the *Rack Installation* placemat at Dell.com/poweredgemanuals.
3. If removed, install the optional front bezel.
4. Reconnect the peripherals and connect the system to the electrical outlet.
5. Turn on the system, including any attached peripherals.

Recommended tools

You need the following tools to perform the removal and installation procedures:

- Key to the bezel lock.
This is needed only if your system includes a bezel.
- Phillips #1 screwdriver
- Phillips #2 screwdriver
- Plastic scribe
- Wrist grounding strap

Front bezel (optional)

The front bezel is attached to the front side of the server and prevents accidents while removing the hard drive or when pressing the reset or power button. The front bezel can also be locked for additional security.

Removing the optional front bezel

Before you begin

Follow the safety guidelines listed in the Safety instructions section.

Procedure

1. Locate and remove the bezel key.
 **Note:** The bezel key is attached to the back of the bezel.
2. Unlock the bezel by using the key.
3. Slide the release latch up and pull the left end of the bezel.
4. Unhook the right end, and remove the bezel.

Figure 17 Removing the optional front bezel

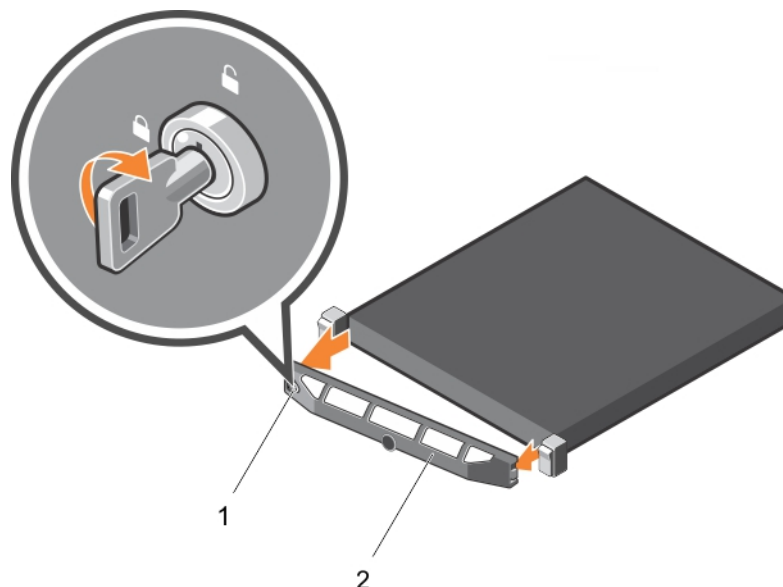

Figure 17 Removing the optional front bezel (continued)

- a. bezel lock
- b. front bezel

Installing the optional front bezel

Before you begin

Follow the safety guidelines listed in the Safety instructions section.

Procedure

1. Locate and remove the bezel key.

 **Note:** The bezel key is attached to the back of the bezel.

2. Hook the right end of the bezel onto the chassis.
3. Fit the free end of the bezel onto the system.
4. Lock the bezel by using the key.

Figure 18 Installing the optional front bezel

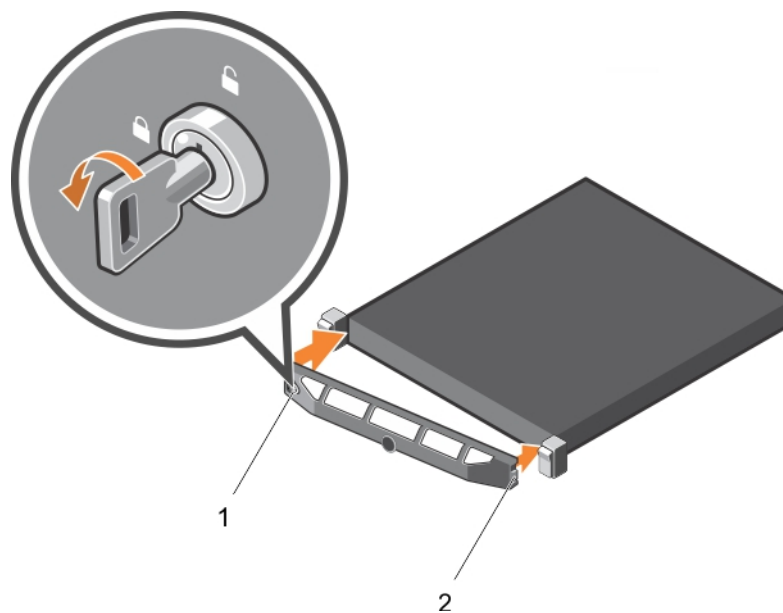

- a. bezel lock
- b. front bezel

System cover

The system cover protects the components inside the system and helps in maintaining air flow inside the system. Removing the system cover actuates the intrusion switch which aids in maintaining system security.

Removing the system cover

Before you begin

1. Follow the safety guidelines listed in the Safety instructions section.
2. Turn off the system, including any attached peripherals.
3. Disconnect the system from the electrical outlet and disconnect the peripherals.
4. If installed, remove the optional bezel. For more information, see the Removing the optional front bezel section.

Procedure

1. Rotate the latch release lock counter clockwise to the unlocked position.
2. Lift the latch toward the back of the system.

The system cover slides back and the tabs on the system cover disengage from the slots on the chassis.

 **Note:** The position of the latch may vary depending on the configuration of your system.

3. Hold the cover on both sides, and lift the cover away from the system.

Figure 19 Removing the system cover

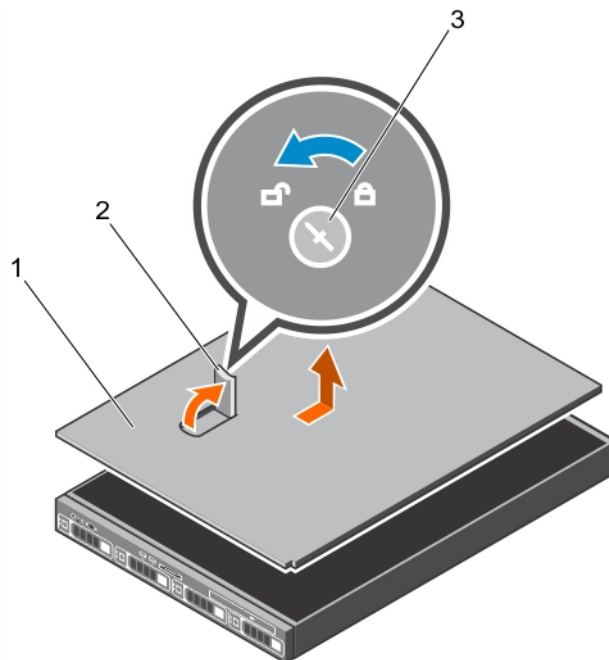

- a. system cover
- b. latch
- c. latch release lock

After you finish

1. Install the system cover.

Installing the system cover

Before you begin

1. Follow the safety guidelines listed in the Safety instructions section.
2. Ensure that all internal cables are connected and placed out of the way and no tools or extra parts are left inside the system.

Procedure

1. Align the slots on the system cover with the tabs on the chassis.
2. Push the system cover latch down to move the system cover into the closed position.

The system cover slides forward and the slots on the system cover engage with the tabs on the chassis. The system cover latch locks into place when the system cover is completely engaged with the tabs on the chassis.

3. Rotate the latch release lock clockwise to the locked position.

Figure 20 Installing the system cover

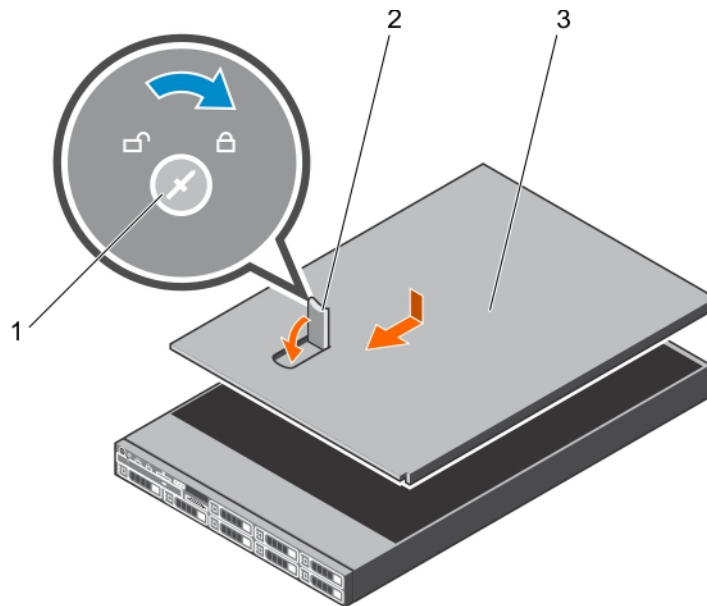

- a. latch release lock
- b. latch
- c. system cover

After you finish

1. If removed, install the front bezel.
2. Reconnect the peripherals and connect the system to the electrical outlet.
3. Turn on the system, including any attached peripherals.

Inside the system

CAUTION Many repairs may only be done by a certified service technician. You should only perform troubleshooting and simple repairs as authorized in your product documentation, or as directed by the online or telephone service and support team. Damage due to servicing that is not authorized by Dell is not covered by your warranty. Read and follow the safety instructions that are shipped with your product.

Figure 21 Inside the system—with a cabled power supply

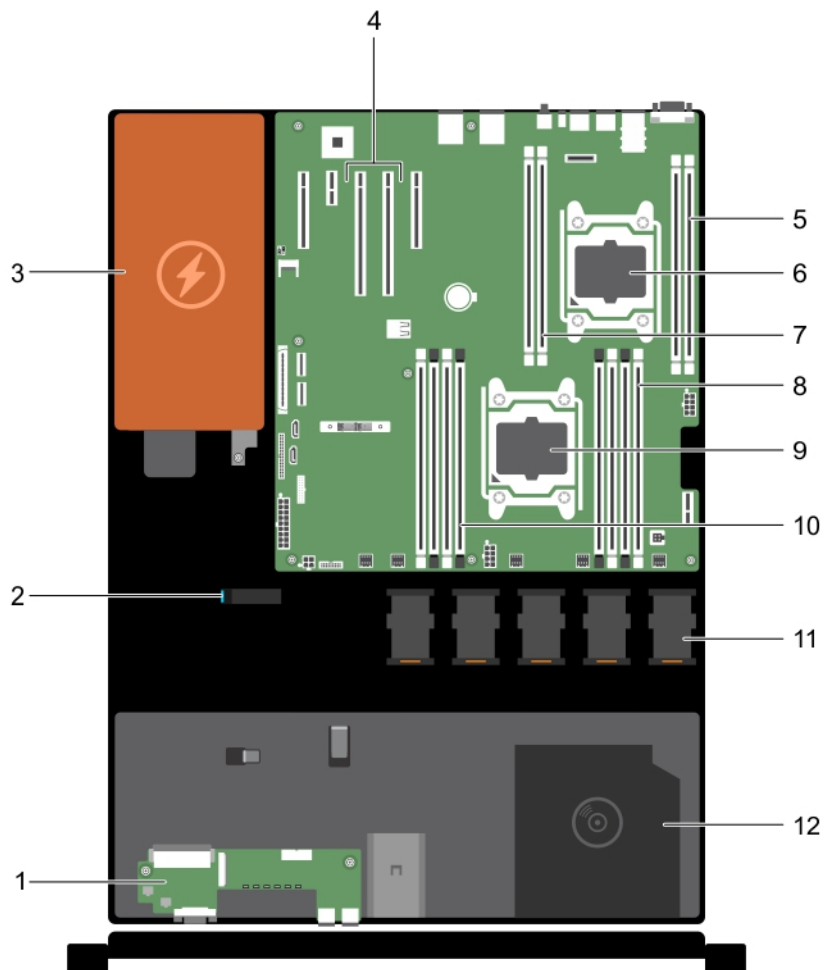

1. control panel
2. cable routing latch
3. power supply unit
4. expansion-card riser connector (2)
5. memory-module socket (B3, B4)
6. processor 2
7. memory-module socket (B1, B2)

Figure 21 Inside the system—with a cabled power supply (continued)

- 8. memory-module socket (A1, A5, A2, A6)
- 9. processor 1
- 10. memory-module socket (A3, A7, A4, A8)
- 11. cooling fan (5)
- 12. optical drive (optional)

Figure 22 Inside the system—with redundant power supplies

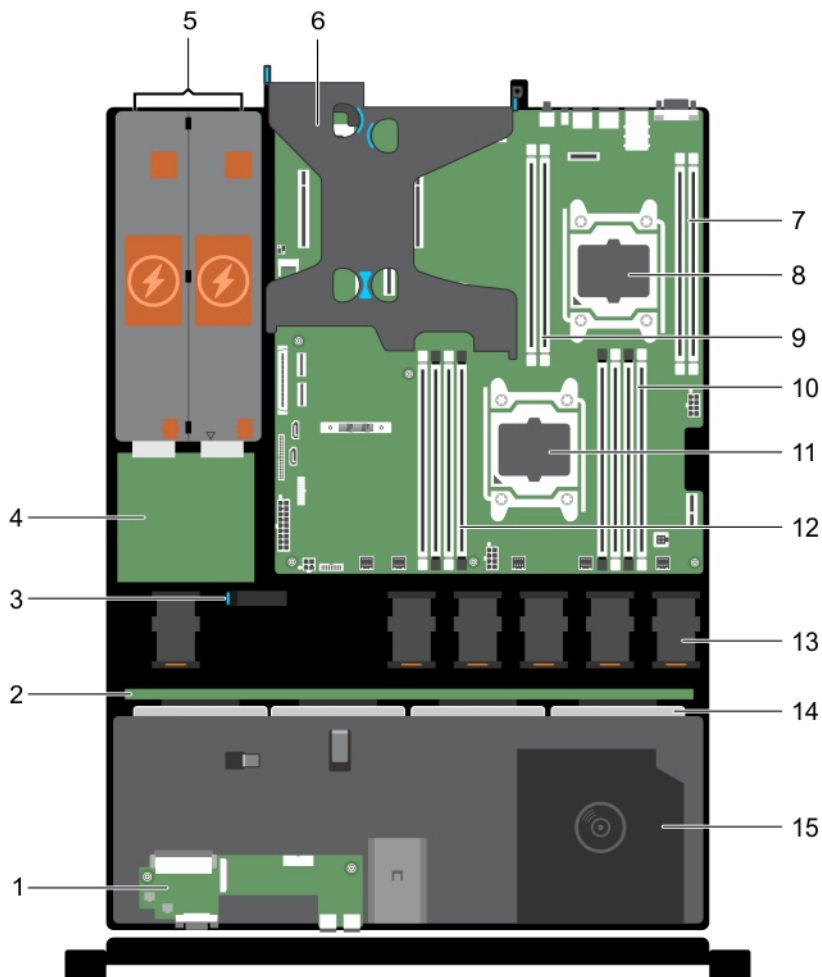

- 1. control panel
- 2. hard drive/SSD backplane
- 3. cable routing latch
- 4. power interposer board
- 5. power supply units (2)
- 6. PCIe expansion card riser (optional)

Figure 22 Inside the system—with redundant power supplies (continued)

7. memory-module socket (B3, B4)
8. processor 2
9. memory-module socket (B1, B2)
10. memory-module socket (A1, A5, A2, A6)
11. processor 1
12. memory-module socket (A3, A7, A4, A8)
13. cooling fan (6)
14. hard drives/SSDs
15. optical drive

Cooling shroud

The cooling shroud has aerodynamically placed openings that direct the airflow across the entire system. The airflow passes through all the critical parts of the system, where the vacuum pulls air across the entire surface area of the heat sink, thus allowing increased cooling.

Removing the cooling shroud

Before you begin

CAUTION Many repairs may only be done by a certified service technician. You should only perform troubleshooting and simple repairs as authorized in your product documentation, or as directed by the online or telephone service and support team. Damage due to servicing that is not authorized by Dell is not covered by your warranty. Read and follow the safety instructions that are shipped with your product.

CAUTION Never operate your system with the cooling shroud removed. The system may get overheated quickly, resulting in shutdown of the system and loss of data.

1. Follow the safety guidelines listed in the Safety instructions section.
2. Follow the procedure listed in the Before working inside your system section.

Procedure

1. Holding the touch points, lift the cooling shroud away from the system.

Figure 23 Removing the cooling shroud

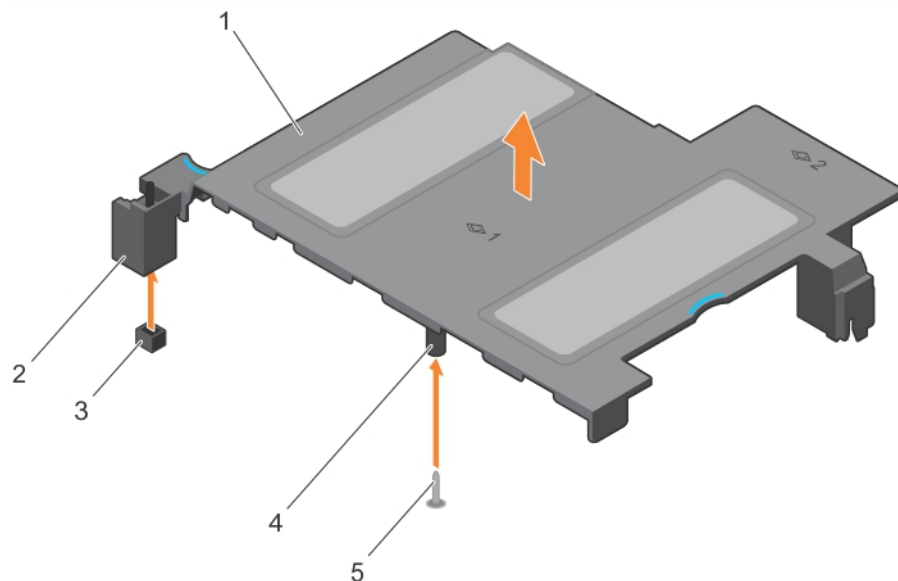

- a. cooling shroud
- b. intrusion switch
- c. intrusion switch connector on the system board
- d. guide on the cooling shroud
- e. guide pin

After you finish

1. Install the cooling shroud.
2. Follow the procedure listed in the After working inside your system section.

Installing the cooling shroud**Before you begin**

CAUTION Many repairs may only be done by a certified service technician. You should only perform troubleshooting and simple repairs as authorized in your product documentation, or as directed by the online or telephone service and support team. Damage due to servicing that is not authorized by Dell is not covered by your warranty. Read and follow the safety instructions that are shipped with your product.

1. Follow the safety guidelines listed in the Safety instructions section.
2. Follow the procedure listed in the Before working inside your system section.
3. If applicable, route the cables inside the system along the chassis wall and secure the cables by using the cable-securing bracket.

Procedure

1. Align the tabs on the cooling shroud with the securing slots on the chassis.
 - a. Align the cooling shroud with the guide pin on the system board.
 - b. Align the intrusion switch with the intrusion switch connector on the system board.
2. Lower the cooling shroud into the chassis until it is firmly seated.

When firmly seated, the memory socket numbers marked on the cooling shroud align with the respective memory sockets.

Figure 24 Installing the cooling shroud

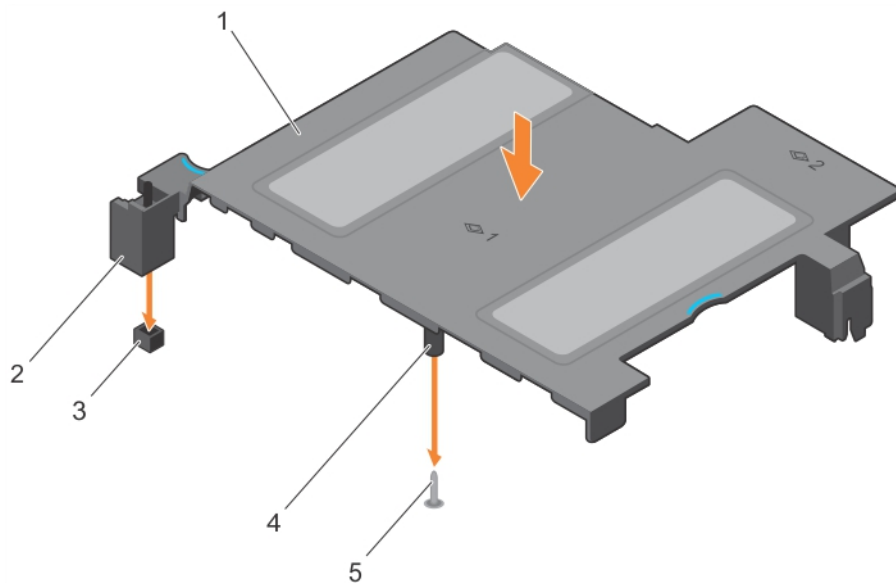

- a. cooling shroud
- b. intrusion switch
- c. intrusion switch connector on the system board

Figure 24 Installing the cooling shroud (continued)

- d. guide on the cooling shroud
- e. guide pin

After you finish

1. Follow the procedure listed in the After working inside your system section.

System memory

Your system supports DDR4 registered DIMMs (RDIMMs).

 **Note:** MT/s indicates DIMM speed in MegaTransfers per second.

Memory bus operating frequency can be 2400 MT/s, 2133 MT/s, or 1866 MT/s depending on the following factors:

- System profile selected (for example, Performance Optimized, Custom, or Dense Configuration Optimized)
- Maximum supported DIMM frequency of the processors

The system contains 12 memory sockets split into four sets — two sets of 4 sockets and two sets of 2 sockets each. Each 4-socket set is organized into two channels and each 2-socket set is organized into one channel. In each channel of the 4-socket set, the release levers of the first socket are marked white and the second socket black. In the 2-socket set, each release lever is marked white.

 **Note:** DIMMs in sockets A1 to A8 are assigned to processor 1 and DIMMs in sockets B1 to B4 are assigned to processor 2.

Figure 25 System memory board

Memory channels are organized as follows:

Processor 1

channel 0: memory sockets A1 and A5

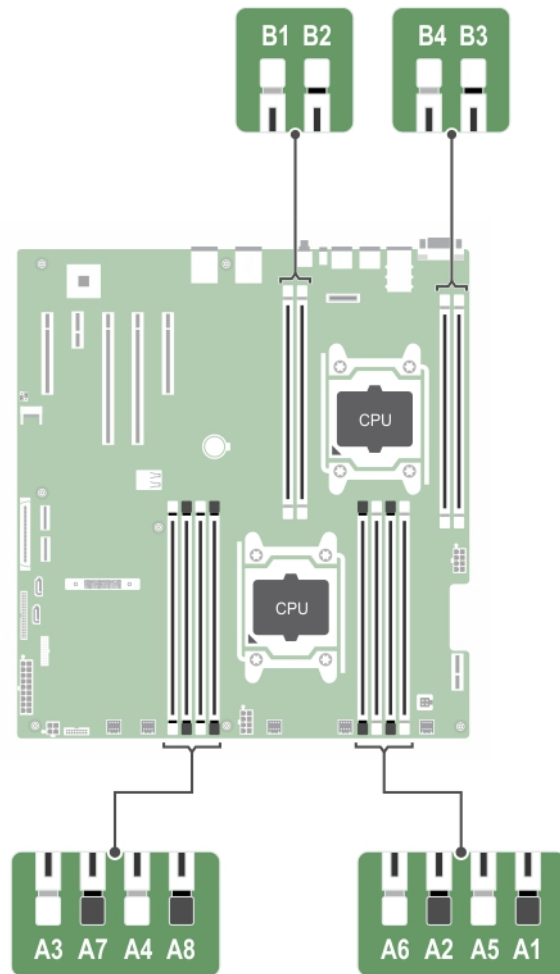
channel 1: memory sockets A2 and A6

channel 2: memory sockets A3 and A7

channel 3: memory sockets A4 and A8

Processor 2

channel 0: memory sockets B1

channel 1: memory sockets B2

channel 2: memory sockets B3

channel 3: memory sockets B4

The following table shows the memory populations and operating frequencies for the supported configurations.

This table describe about the memory populations and operating frequencies for the supported configurations.

Table 37 Supported configurations

DIMM type	DIMMs populated/channel	Voltage	Operating frequency (in MT/s)	Maximum DIMM rank/channel
RDIMM	1 2	1.2 V	2400, 2133, 1866	Dual rank or single rank

General memory module installation guidelines

Note: Memory configurations that fail to observe these guidelines can prevent your system from booting, stop responding during memory configuration, or operating with reduced memory.

The system supports Flexible Memory Configuration, enabling the system to be configured and run in any valid chipset architectural configuration. The following are the recommended guidelines for installing memory modules:

- RDIMMs and LRDIMMs must not be mixed.
- x4 and x8 DRAM based memory modules can be mixed. For more information, see the Mode-specific guidelines section.
- Up to three dual- or single-rank RDIMMs can be populated per channel.
- Up to three LRDIMMs can be populated per channel regardless of rank count.
- If memory modules with different speeds are installed, they will operate at the speed of the slowest installed memory module(s) or slower depending on system DIMM configuration.
- Populate memory module sockets only if a processor is installed. For single-processor systems, sockets A1 to A12 are available. For dual-processor systems, sockets A1 to A12 and sockets B1 to B12 are available.
- Populate all the sockets with white release tabs first, followed by the black release tabs, and then the green release tabs.
- When mixing memory modules with different capacities, populate the sockets with memory modules with highest capacity first. For example, if you want to mix 4 GB and 8 GB memory modules, populate 8 GB memory modules in the sockets with white release tabs and 4 GB memory modules in the sockets with black release tabs.
- In a dual-processor configuration, the memory configuration for each processor should be identical. For example, if you populate socket A1 for processor 1, then populate socket B1 for processor 2, and so on.
- Memory modules of different capacities can be mixed provided other memory population rules are followed (for example, 4 GB and 8 GB memory modules can be mixed).
- Mixing of more than two memory module capacities in a system is not supported.
- Populate four memory modules per processor (one DIMM per channel) at a time to maximize performance.

Mode-specific guidelines

Four memory channels are allocated to each processor. The allowable configurations depend on the memory mode selected.

Advanced Error Correction Code (lockstep)

Advanced Error Correction Code (ECC) mode extends SDDC from x4 DRAM based DIMMs to both x4 and x8 DRAMs. This protects against single DRAM chip failures during normal operation.

The installation guidelines for memory modules are as follows:

- Memory modules must be identical in size, speed, and technology.
- DIMMs installed in memory sockets with white release levers must be identical and the same rule applies for sockets with black release levers. This ensures that identical DIMMs are installed in matched pair—for example, A1 with A2, A3 with A4, A5 with A6, and so on.

Memory optimized (independent channel) mode

This mode supports Single Device Data Correction (SDDC) only for memory modules that use x4 device width. It does not impose any specific slot population requirements.

Memory sparing

Note: To use memory sparing, this feature must be enabled in System Setup.

In this mode, one rank per channel is reserved as a spare. If persistent correctable errors are detected on a rank, the data from this rank is copied to the spare rank, and the failed rank is disabled.

With memory sparing enabled, the system memory available to the operating system is reduced by one rank per channel. For example, in a dual-processor configuration with sixteen 4 GB single-rank memory modules, the available system memory is: $\frac{3}{4}$ (ranks/channel) \times 16 (memory modules) \times 4 GB = 48 GB, and not 16 (memory modules) \times 4 GB = 64 GB.

Note: Memory sparing does not offer protection against a multi-bit uncorrectable error.

Note: Both Advanced ECC/Lockstep and Optimizer modes support memory sparing.

Sample memory configurations

The following tables show sample memory configurations for one and two processor configurations that follow the appropriate memory guidelines.

Note: 1R and 2R in the following tables indicate single- and dual-rank DIMMs respectively.

Memory configurations—single processor

Table 38 Memory configurations—single processor

System Capacity (in GB)	DIMM Size (in GB)	Number of DIMMs	DIMM Rank, Organization, and Frequency	DIMM Slot Population
4	4	1	1R, x8, 2400 MT/s, 1R, x8, 2133 MT/s, 1R, x8, 1866 MT/s	A1
8	4	2	1R, x8, 2400 MT/s, 1R, x8, 2133 MT/s, 1R, x8, 1866 MT/s	A1, A2

Table 38 Memory configurations—single processor (continued)

System Capacity (in GB)	DIMM Size (in GB)	Number of DIMMs	DIMM Rank, Organization, and Frequency	DIMM Slot Population
	8	1	1R, x8, 2400 MT/s, 1R, x8, 2133 MT/s, 1R, x8, 1866 MT/s	A1
16	4	4	1R, x8, 2400 MT/s, 1R, x8, 2133 MT/s, 1R, x8, 1866 MT/s	A1, A2, A3, A4
	8	2	2R, x8, 2400 MT/s, 2R, x8, 2133 MT/s, 2R, x8, 1866 MT/s	A1, A2
	16	1	2R, x8, 2400 MT/s, 2R, x8, 2133 MT/s, 2R, x8, 1866 MT/s	A1
24	4	6	1R, x8, 2400 MT/s, 1R, x8, 2133 MT/s, 1R, x8, 1866 MT/s	A1, A2, A3, A4, A5, A6
	8	3	1R, x8, 2400 MT/s, 1R, x8, 2133 MT/s, 1R, x8, 1866 MT/s	A1, A2, A3
32	4	8	1R, x8, 2400 MT/s, 1R, x8, 2133 MT/s, 1R, x8, 1866 MT/s	A1, A2, A3, A4, A5, A6, A7, A8
	8	4	1R, x8, 2400 MT/s, 1R, x8, 2133 MT/s, 1R, x8, 1866 MT/s	A1, A2, A3, A4
	16	2	1R, x8, 2400 MT/s, 1R, x8, 2133 MT/s, 1R, x8, 1866 MT/s	A1, A2
	32	1	1R, x8, 2400 MT/s, 1R, x8, 2133 MT/s, 1R, x8, 1866 MT/s	A1
48	8	6	2R, x8, 2400 MT/s, 2R, x8, 2133 MT/s, 2R, x8, 1866 MT/s	A1, A2, A3, A4, A5, A6

Table 38 Memory configurations—single processor (continued)

System Capacity (in GB)	DIMM Size (in GB)	Number of DIMMs	DIMM Rank, Organization, and Frequency	DIMM Slot Population
	16	3	2R, x8, 2400 MT/s, 2R, x8, 2133 MT/s, 2R, x8, 1866 MT/s	A1, A2, A3
64	8	8	2R, x8, 2400 MT/s, 2R, x8, 2133 MT/s, 2R, x8, 1866 MT/s	A1, A2, A3, A4, A5, A6, A7, A8
	16	4	2R, x8, 2400 MT/s, 2R, x8, 2133 MT/s, 2R, x8, 1866 MT/s	A1, A2, A3, A4
	32	2	2R, x8, 2400 MT/s, 2R, x8, 2133 MT/s, 2R, x8, 1866 MT/s	A1, A2
96	16	6	2R, x8, 2400 MT/s, 2R, x4, 2133 MT/s, 2R, x4, 1866 MT/s	A1, A2, A3, A4, A5, A6
	32	3	2R, x8, 2400 MT/s, 2R, x4, 2133 MT/s, 2R, x4, 1866 MT/s	A1, A2, A3
128	16	8	2R, x8, 2400 MT/s, 2R, x4, 2133 MT/s, 2R, x4, 1866 MT/s,	A1, A2, A3, A4, A5, A6, A7, A8
	32	4	2R, x8, 2400 MT/s, 2R, x4, 2133 MT/s, 2R, x4, 1866 MT/s,	A1, A2, A3, A4
192	32	6	2R, x4, 2400 MT/s 2R, x4, 2133 MT/s 2R, x4, 1866 MT/s	A1, A2, A3, A4, A5, A6
256	32	8	2R, x4, 2400 MT/s 2R, x4, 2133 MT/s 2R, x4, 1866 MT/s	A1, A2, A3, A4, A5, A6, A7, A8

Memory configurations—two processors

Table 39 Memory configurations—two processors

System Capacity (in GB)	DIMM Size (in GB)	Number of DIMMs	DIMM Rank, Organization, and Frequency	DIMM Slot Population	
8	4	2	1R, x8, 2400 MT/s,	A1, B1	
			1R, x8, 2133 MT/s,		
			1R, x8, 1866 MT/s		
16	4	4	1R, x8, 2400 MT/s,	A1, A2, B1, B2	
			1R, x8, 2133 MT/s,		
			1R, x8, 1866 MT/s		
	8	2		1R, x8, 2400 MT/s,	A1, B1
				1R, x8, 2133 MT/s,	
				1R, x8, 1866 MT/s	
24	4	6	1R, x8, 2400 MT/s,	A1, A2, A3, B1, B2, B3	
			1R, x8, 2133 MT/s,		
			1R, x8, 1866 MT/s		
32	4	8	1R, x8, 2400 MT/s,	A1, A2, A3, A4, B1, B2, B3, B4	
			1R, x8, 2133 MT/s,		
			1R, x8, 1866 MT/s		
	8	4		2R, x8, 2400 MT/s,	A1, A2, B1, B2
				2R, x8, 2133 MT/s,	
				2R, x8, 1866 MT/s	
16	2		2R, x8, 2400 MT/s,	A1, B1	
			2R, x8, 2133 MT/s,		
			2R, x8, 1866 MT/s		
48	4	12	2R, x8, 2400 MT/s,	A1, A2, A3, A4, A5, A6, A7, A8, B1, B2, B3, B4	
			2R, x8, 2133 MT/s,		
			2R, x8, 1866 MT/s		
	8	6		2R, x8, 2400 MT/s,	A1, A2, A3, B1, B2, B3
				2R, x8, 2133 MT/s,	
				2R, x8, 1866 MT/s	
64	8	8	2R, x8, 2400 MT/s,	A1, A2, A3, A4, B1, B2, B3, B4	
			2R, x8, 2133 MT/s,		
			2R, x8, 1866 MT/s		
16	4		2R, x8, 2400 MT/s,	A1, A2, B1, B2	
			2R, x8, 2133 MT/s,		
			2R, x8, 1866 MT/s		

Table 39 Memory configurations—two processors (continued)

System Capacity (in GB)	DIMM Size (in GB)	Number of DIMMs	DIMM Rank, Organization, and Frequency	DIMM Slot Population
	32	2	2R, x8, 2400 MT/s, 2R, x8, 2133 MT/s, 2R, x8, 1866 MT/s	A1, B1
96	8	12	2R, x8, 2400 MT/s, 2R, x8, 2133 MT/s, 2R, x8, 1866 MT/s	A1, A2, A3, A4, A5, A6,A7,A8, B1, B2, B3, B4
	16	6	2R, x8, 2400 MT/s, 2R, x8, 2133 MT/s, 2R, x8, 1866 MT/s	A1, A2, A3, B1, B2, B3
128	16	8	2R, x4, 2400 MT/s, 2R, x4, 2133 MT/s, 2R, x4, 1866 MT/s	A1, A2, A3, A4, B1, B2, B3, B4
	32	4	2R, x4, 2400 MT/s, 2R, x4, 2133 MT/s, 2R, x4, 1866 MT/s	A1, A2, B1, B2
160	16 and 8	12	2R, x4, 2400 MT/s, 2R, x8, 2400 MT/s, 2R, x4, 2133 MT/s, 2R, x8, 2133 MT/s, 2R, x4, 1866 MT/s, 2R, x8, 1866 MT/s	A1, A2, A3, A4, A5, A6,A7,A8, B1, B2, B3, B4 Note: 16 GB DIMMs must be installed in slots numbered A1, A2, A3, A4, B1, B2, B3, and B4 and 8 GB DIMMs must be installed in slots A5, A6, A7, and A8.
192	16	12	2R, x4, 2400 MT/s, 2R, x4, 2133 MT/s, 2R, x4, 1866 MT/s	A1, A2, A3, A4, A5, A6,A7,A8, B1, B2, B3, B4
	32	6	2R, x4, 2400 MT/s, 2R, x4, 2133 MT/s, 2R, x4, 1866 MT/s	A1, A2, A3, B1, B2, B3
256	32	8	2R, x4, 2400 MT/s, 2R, x4, 2133 MT/s, 2R, x4, 1866 MT/s	A1, A2, A3, A4, B1, B2, B3, B4
384	32	12	2R, x4, 2400 MT/s, 2R, x4, 2133 MT/s	A1, A2, A3, A4, A5, A6, A7, A8, B1, B2, B3, B4

Table 39 Memory configurations—two processors (continued)

System Capacity (in GB)	DIMM Size (in GB)	Number of DIMMs	DIMM Rank, Organization, and Frequency	DIMM Slot Population
			2R, x4, 1866 MT/s	

Removing memory modules

Before you begin

CAUTION Many repairs may only be done by a certified service technician. You should only perform troubleshooting and simple repairs as authorized in your product documentation, or as directed by the online or telephone service and support team. Damage due to servicing that is not authorized by Dell is not covered by your warranty. Read and follow the safety instructions that are shipped with your product.

1. Follow the safety guidelines listed in the Safety instructions section.
2. Follow the procedure listed in the Before working inside your system section.
3. Remove the cooling shroud.

Note: The memory modules are hot to touch for some time after the system has been powered down. Allow the memory modules to cool before handling them. Handle the memory modules by the card edges and avoid touching the components or metallic contacts on the memory module.

CAUTION To ensure proper system cooling, memory module blanks must be installed in any memory socket that is not occupied. Remove memory module blanks only if you intend to install memory modules in those sockets.

Procedure

1. Locate the appropriate memory module socket.

CAUTION Handle each memory module only by the card edges, ensuring not to touch the middle of the memory module or metallic contacts.

2. To release the memory module from the socket, simultaneously press the ejectors on both ends of the memory module socket.
3. Lift and remove the memory module from the system.

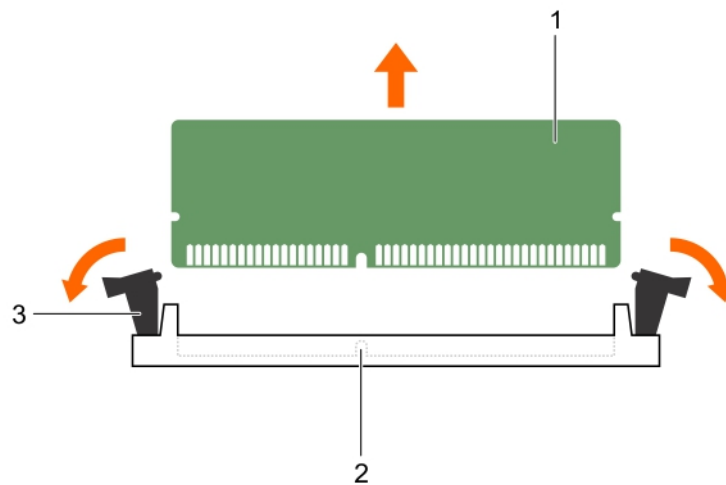
Figure 26 Removing the memory module

- a. memory module
- b. memory module socket
- c. memory module socket ejector (2)

After you finish

1. Install the memory module.
 - Note:** If you are removing the memory module permanently, install a memory module blank.
2. Install the cooling shroud.
3. Follow the procedure listed in the After working inside your system section.

Installing memory modules**Before you begin**

Note: The memory modules are hot to touch for some time after the system has been powered down. Allow the memory modules to cool before handling them. Handle the memory modules by the card edges and avoid touching the components or metallic contacts on the memory module.

CAUTION Many repairs may only be done by a certified service technician. You should only perform troubleshooting and simple repairs as authorized in your product documentation, or as directed by the online or telephone service and support team. Damage due to servicing that is not authorized by Dell is not covered by your warranty. Read and follow the safety instructions that are shipped with your product.

1. Follow the safety guidelines listed in the Safety instructions section.
2. Follow the procedure listed in the Before working inside your system section.
3. Remove the cooling shroud.

Procedure

1. Locate the appropriate memory module socket.

CAUTION Handle each memory module only by the card edges, ensuring not to touch the middle of the memory module or metallic contacts.

2. Open the ejectors on the memory module socket outward to allow the memory module to be inserted into the socket.
3. Align the edge connector of the memory module with the alignment key of the memory module socket, and insert the memory module in the socket.

CAUTION Do not apply pressure at the center of the memory module; apply pressure at both ends of the memory module evenly.

Note: The memory module socket has an alignment key that enables you to install the memory module in the socket in only one orientation.

4. Press the memory module with your thumbs until the socket levers firmly click into place.

When the memory module is properly seated in the socket, the levers on the memory module socket align with the levers on the other sockets that have memory modules installed.

Figure 27 Installing the memory module

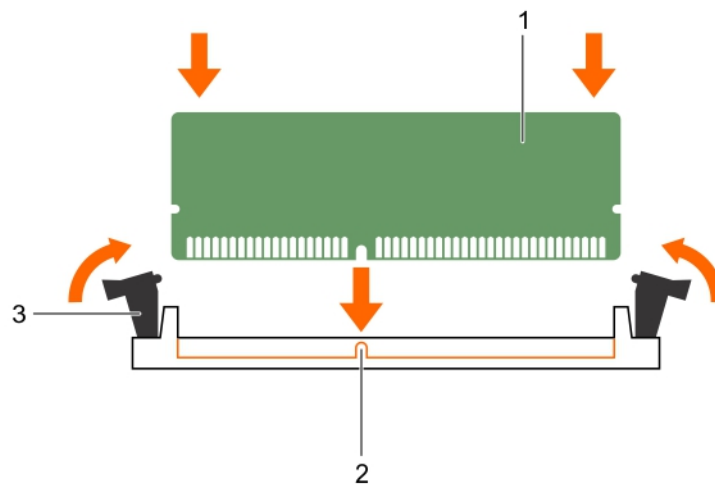

- a. memory module
- b. alignment key
- c. memory module socket ejector (2)

After you finish

1. Install the cooling shroud.
2. Follow the procedure listed in the After working inside your system section.
3. Press F2 to enter System Setup, and check the **System Memory** setting. The system should have already changed the value to reflect the installed memory.
4. If the value is incorrect, one or more of the memory modules may not be installed properly. Ensure that the memory module is firmly seated in the memory module socket.

5. Run the system memory test in system diagnostics.

Hard drives

Depending on the configuration, your system supports one of the following:

Four hard-drive systems

Up to four 3.5-inch cabled hard drives, or

Up to four 3.5-inch hot-swappable SAS hard drives, SATA hard drives, or SATA SSDs or

Up to four 2.5-inch hot-swappable SAS hard drives, SATA hard drives, or SATA SSDs

Eight hard-drive systems

Up to eight 2.5-inch hot-swappable SAS hard drives, SATA hard drives, or SATA SSDs

Ten hard-drive systems

Up to ten 2.5-inch hot-swappable SATA hard drives or SATA SSDs

 **Note:** SSD/SAS/SATA hard drives cannot be mixed in a system.

The hot-swappable hard drives connect to the system board through the hard-drive backplane. Hot-swappable hard drives are supplied in hot-swappable hard-drive carriers that fit in the hard-drive slots.

 **CAUTION** Before attempting to remove or install a hot-swappable hard drive while the system is running, see the documentation for the storage controller card to ensure that the host adapter is configured correctly to support hot-swap hard drive removal and insertion.

 **CAUTION** Do not turn off or reboot your system while the hard drive is being formatted. Doing so can cause a hard drive failure.

 **Note:** Use only hard drives that have been tested and approved for use with the hard-drive backplane.

When you format a hard drive, allow enough time for the formatting to be completed. Be aware that high-capacity hard drives can take a number of hours to format.

Removing a 2.5-inch hard drive blank

Before you begin

 **CAUTION** Many repairs may only be done by a certified service technician. You should only perform troubleshooting and simple repairs as authorized in your product documentation, or as directed by the online or telephone service and support team. Damage due to servicing that is not authorized by Dell is not covered by your warranty. Read and follow the safety instructions that are shipped with your product.

 **CAUTION** To maintain proper system cooling, all empty hard drive slots must have hard drive blanks installed.

1. Follow the safety guidelines listed in the Safety instructions section.
2. If installed, remove the front bezel.

Procedure

1. Press the release button and slide the hard drive blank out of the hard drive slot.

Figure 28 Removing a 2.5-inch hard drive blank

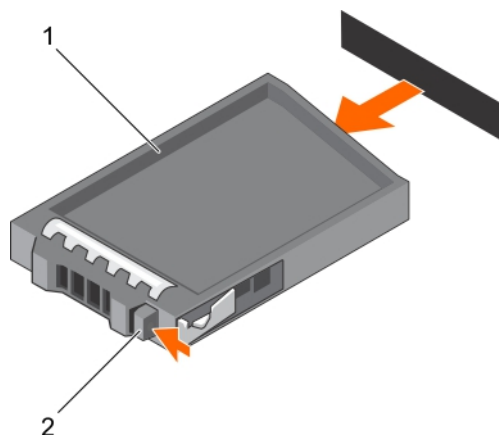

- a. hard drive blank
- b. release button

After you finish

If removed, install the front bezel.

Installing a 2.5-inch hard drive blank

Before you begin

1. Follow the safety guidelines listed in the Safety instructions section.
2. If installed, remove the front bezel.

Procedure

1. Insert the hard drive blank into the hard drive slot until the release button clicks into place.

Figure 29 Installing a 2.5-inch hard drive blank

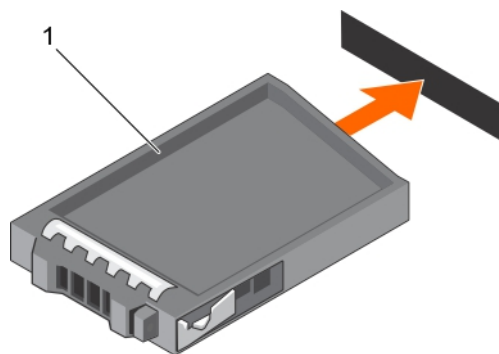

- a. hard drive blank

After you finish

If removed, install the front bezel.

Removing a 3.5-inch hard drive blank

Before you begin

CAUTION Many repairs may only be done by a certified service technician. You should only perform troubleshooting and simple repairs as authorized in your product documentation, or as directed by the online or telephone service and support team. Damage due to servicing that is not authorized by Dell is not covered by your warranty. Read and follow the safety instructions that came with the product.

CAUTION To maintain proper system cooling, all empty hard drive slots must have hard drive blanks installed.

1. Follow the safety guidelines listed in the Safety instructions section.
2. If installed, remove the front bezel.

Procedure

1. Press the release button and slide the blank out of the hard drive slot.

Figure 30 Removing a 3.5-inch hard drive blank

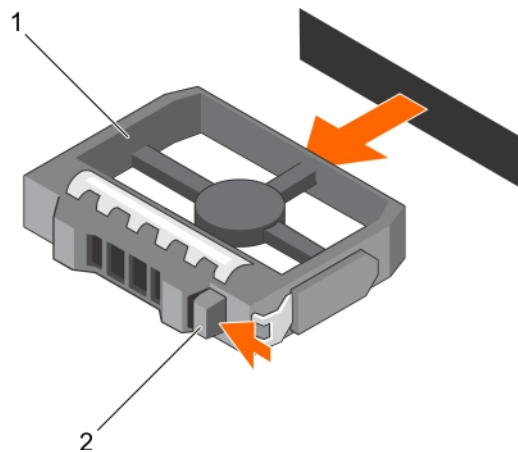

- a. hard drive blank
- b. release button

After you finish

If applicable, install the front bezel.

Installing a 3.5-inch hard drive blank

Before you begin

1. Follow the safety guidelines listed in the Safety instructions section.
2. If installed, remove the front bezel.

Procedure

1. Insert the hard drive blank into the hard drive slot until the release button clicks into place.

Figure 31 Installing a 3.5-inch hard drive blank

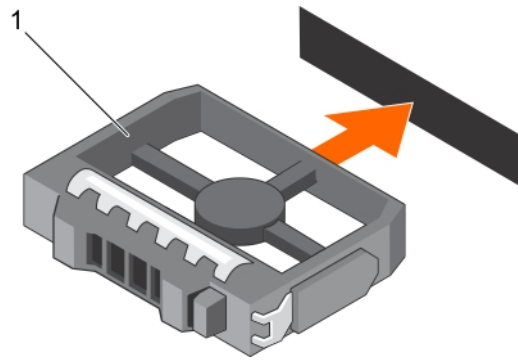

a. hard drive blank

After you finish

If applicable, install the front bezel.

Removing a 3.5-inch cabled hard drive carrier

Before you begin

CAUTION Many repairs may only be done by a certified service technician. You should only perform troubleshooting and simple repairs as authorized in your product documentation, or as directed by the online or telephone service and support team. Damage due to servicing that is not authorized by Dell is not covered by your warranty. Read and follow the safety instructions that are shipped with your product.

1. Follow the safety guidelines listed in the Safety instructions section.
2. Follow the procedure listed in the Before working inside your system section.
3. If installed, remove the front bezel.
4. If connected, disconnect the power and data cable from the hard drive.

Note: The empty cabled hard drive carrier can be used as a blank.

Procedure

1. Press the release tab on the hard drive carrier and slide the hard drive carrier out of the hard drive slot.

CAUTION To maintain proper system cooling, all empty hard drive slots must have hard drive carrier blanks installed.

2. Insert a hard drive blank in the empty hard drive slot.

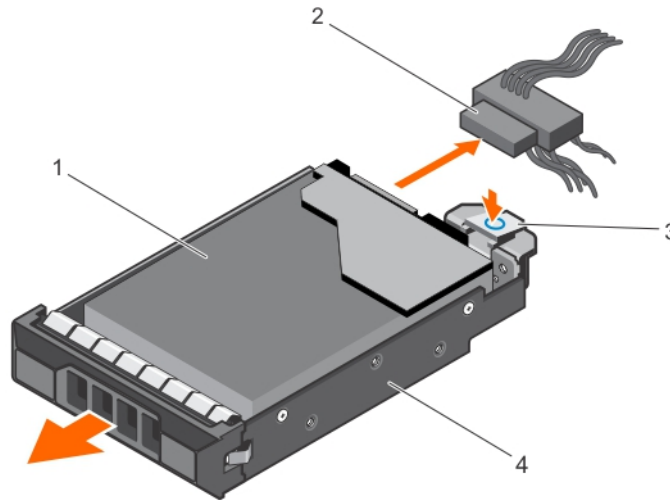
Figure 32 Removing a cabled hard drive carrier

- a. hard drive
- b. power/data cable
- c. release tab
- d. hard drive carrier

After you finish

1. If required, install a hard drive in the hard drive carrier and install the hard drive carrier into the hard drive slot in the system.
2. If you are not replacing the hard drive immediately, insert a hard drive carrier in the empty hard drive slot.
3. Follow the procedure listed in the After working inside your system section.

Installing a 3.5-inch cabled hard drive carrier**Before you begin**

CAUTION Many repairs may only be done by a certified service technician. You should only perform troubleshooting and simple repairs as authorized in your product documentation, or as directed by the online or telephone service and support team. Damage due to servicing that is not authorized by Dell is not covered by your warranty. Read and follow the safety instructions that are shipped with your product.

1. Follow the safety guidelines listed in the Safety instructions section.
2. Follow the procedure listed in the Before working inside your system section.
3. Keep the Phillips #2 screwdriver ready.

Procedure

1. Press the release tab on the hard drive carrier and slide the hard drive carrier out of the system.
2. Install the hard drive into the hard drive carrier.
 - a. Secure the hard drive in place with screws.
3. Insert the hard drive carrier into the hard drive slot, and push the hard drive carrier until it clicks into place.

4. Connect the power and data cable to the hard drive.
 - If connecting to the integrated SATA controller (SATA hard drives only), connect the SATA data cable to the SATA_A-D connector on the system board.
 - If connecting to a SAS RAID controller card (SAS or SATA hard drives), connect the data cable to the connector on the card.

Figure 33 Installing a cabled hard drive carrier

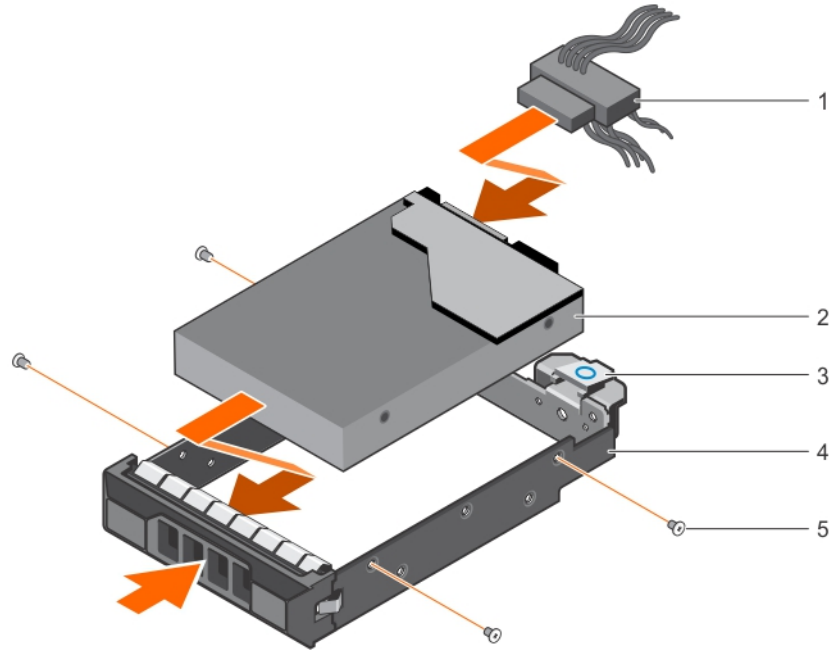

- a. power/data cable
- b. hard drive
- c. release tab
- d. hard drive carrier
- e. screw (4)

After you finish

1. Enter System Setup and ensure that the controller of the hard drive is enabled.
2. Exit System Setup and reboot the system.
3. Install any software required for the hard drive operation as described in the documentation for the hard drive.
4. Follow the procedure listed in the After working inside your system section.

Removing a hot swappable hard drive carrier

Before you begin

CAUTION Many repairs may only be done by a certified service technician. You should only perform troubleshooting and simple repairs as authorized in your product documentation, or as directed by the online or telephone service and support team. Damage due to servicing that is not authorized by Dell is not covered by your warranty. Read and follow the safety instructions that came with the product.

1. Follow the safety guidelines listed in the Safety instructions section.
2. If installed, remove the front bezel.
3. Using the management software, prepare the hard drive for removal. For more information, see the documentation for the storage controller.
If the hard drive is online, the green activity or fault indicator flashes when the hard drive is turned off. You can remove the hard drive when the hard drive indicators turn off.

CAUTION To prevent data loss, ensure that your operating system supports hot-swap drive installation. See the documentation supplied with your operating system.

Note: Hot swappable hard drives are supplied in hot swappable hard drive carriers that fit in the hard drive slots.

Procedure

1. Press the release button to open the hard drive carrier release handle.
2. Slide the hard drive carrier out of the hard drive slot.

CAUTION To maintain proper system cooling, all empty hard drive slots must have hard drive carrier blanks installed.

Figure 34 Removing a hot swappable hard drive or SSD

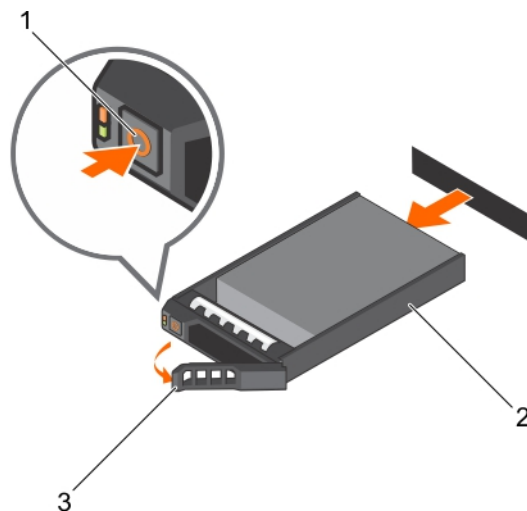

- a. release button
- b. hard drive carrier
- c. hard drive carrier handle

After you finish

1. If you are not replacing the hard drive immediately, insert a hard drive carrier blank in the empty hard drive slot, or install a hard drive carrier.
2. If removed, install the front bezel.

Installing a hot swappable hard drive carrier

Before you begin

CAUTION Many repairs may only be done by a certified service technician. You should only perform troubleshooting and simple repairs as authorized in your product documentation, or as directed by the online or telephone service and support team. Damage due to servicing that is

not authorized by Dell is not covered by your warranty. Read and follow the safety instructions that are shipped with your product.

CAUTION Use only hard drives that have been tested and approved for use with the hard drive backplane.

CAUTION Combining SAS and SATA hard drives in the same RAID volume is not supported.

CAUTION When installing a hard drive, ensure that the adjacent drives are fully installed. Inserting a hard drive carrier and attempting to lock its handle next to a partially installed carrier can damage the partially installed carrier's shield spring and make it unusable.

CAUTION To prevent data loss, ensure that your operating system supports hot-swap drive installation. See the documentation supplied with your operating system.

CAUTION When a replacement hot swappable hard drive is installed and the system is powered on, the hard drive automatically begins to rebuild. Make absolutely sure that the replacement hard drive is blank or contains data that you wish to have over-written. Any data on the replacement hard drive is immediately lost after the hard drive is installed.

Note: Hot swappable hard drives are supplied in hot swappable hard drive carriers that fit in the hard drive slots.

1. If installed, remove the front bezel.
2. If installed, remove the hard drive carrier blank.
3. Install a hot swappable hard drive into the hot swappable hard drive carrier.

Procedure

1. Press the release button on the front of the hot swappable hard drive carrier and open the hot swappable hard drive carrier handle.
2. Insert the hot swappable hard drive carrier into the hard drive slot, and push the hot swappable hard drive carrier until it comes in contact with the backplane.
3. Close the hot swappable hard drive carrier handle to lock the hot swappable hard drive carrier in place.

Figure 35 Installing a hot swappable hard drive carrier

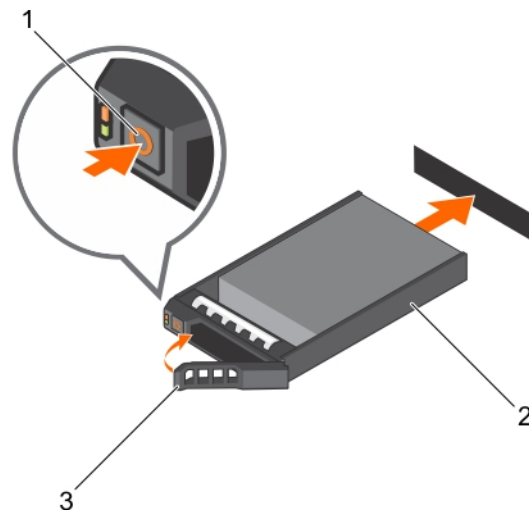

- a. release button
- b. hard drive carrier

Figure 35 Installing a hot swappable hard drive carrier (continued)

c. hard drive carrier handle

After you finish

If removed, install the front bezel.

Removing a 3.5-inch hot swappable hard drive adapter from a 3.5-inch hot swappable hard drive carrier

Before you begin

CAUTION Many repairs may only be done by a certified service technician. You should only perform troubleshooting and simple repairs as authorized in your product documentation, or as directed by the online or telephone service and support team. Damage due to servicing that is not authorized by Dell is not covered by your warranty. Read and follow the safety instructions that are shipped with your product.

1. Follow the safety guidelines listed in safety instructions section.
2. Keep the Phillips #2 screwdriver ready.
3. If installed, remove the front bezel.

Procedure

1. Remove the 3.5-inch hot swappable hard drive carrier from the system.
2. Remove the screws from the rails on the hot swappable hard drive carrier.
3. Lift the 3.5-inch hard drive adapter out of the 3.5-inch hot swappable hard drive carrier.

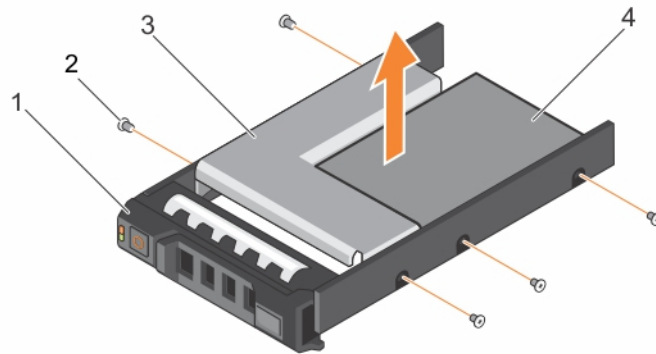
Figure 36 Removing a 3.5-inch hot swappable hard drive adapter from a 3.5-inch hot swappable hard drive carrier

- a. 3.5-inch hard drive carrier
- b. screw (5)
- c. hard drive adapter
- d. 2.5-inch hard drive

After you finish

If removed, install the front bezel.

Installing a 3.5-inch hard drive adapter into a hot swap hard drive carrier

Before you begin

CAUTION Many repairs may only be done by a certified service technician. You should only perform troubleshooting and simple repairs as authorized in your product documentation, or as directed by the online or telephone service and support team. Damage due to servicing that is not authorized by Dell is not covered by your warranty. Read and follow the safety instructions that are shipped with your product.

1. Follow the safety guidelines listed in the Safety instructions section.
2. Keep the Phillips #2 screwdriver ready.
3. If installed, remove the front bezel.
4. Install the 2.5-inch hot swappable hard drive into the hot swappable hard drive adapter.

Procedure

1. Insert the 3.5-inch hard drive adapter into the hot swappable hard drive carrier with the connector end of the hard drive toward the back of the hot swappable hard drive carrier.
2. Align the screw holes on the hard drive with the holes on the hot swappable hard drive carrier.
3. Install the screws to secure the hot swappable hard drive to the hot swappable hard drive carrier.

Figure 37 Installing a 3.5-inch hard drive adapter into a hot swappable hard drive carrier

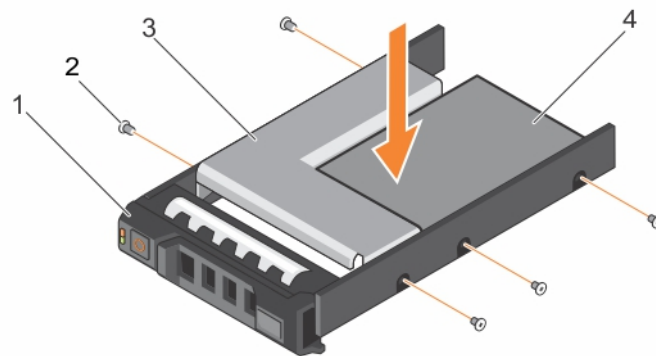

- a. 3.5-inch hard drive carrier
- b. screw (5)
- c. hard drive adapter
- d. 2.5-inch hard drive

After you finish

1. Install the hot swappable hard drive carrier into the system.
2. If removed, install the front bezel.

Removing a 2.5-inch hard drive from a 3.5-inch hard drive adapter

Before you begin

CAUTION Many repairs may only be done by a certified service technician. You should only perform troubleshooting and simple repairs as authorized in your product documentation, or as

directed by the online or telephone service and support team. Damage due to servicing that is not authorized by Dell is not covered by your warranty. Read and follow the safety instructions that came with the product.

1. Follow the safety guidelines listed in the Safety instructions section.
2. Keep the Phillips #2 screwdriver ready.
3. Remove the 3.5-inch hard drive adapter from the 3.5-inch hot swappable hard drive carrier.

Note: A 2.5-inch hot swappable hard drive is installed in a 3.5-inch hard drive adapter, which is then installed in the 3.5-inch hot swappable hard drive carrier.

Procedure

1. Remove the screws from the side of the 3.5-inch hard drive adapter.
2. Remove the hard drive from the 3.5-inch hard drive adapter.

Figure 38 Removing a 2.5-inch hard drive from a 3.5-inch hard drive adapter

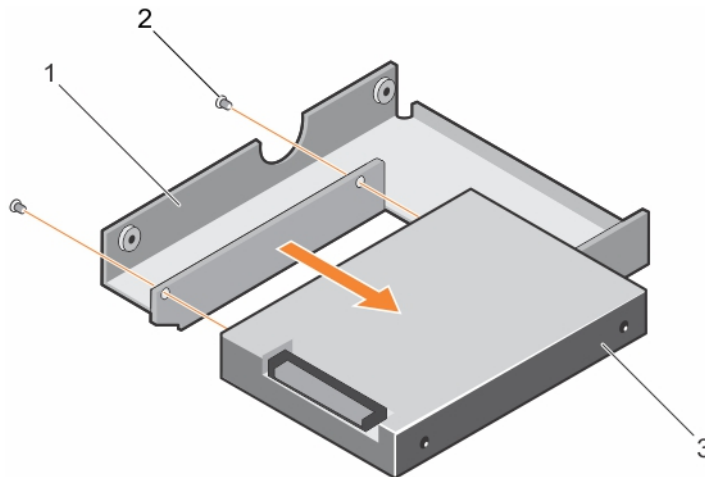

- a. 3.5-inch hard drive adapter
- b. screw (2)
- c. 2.5-inch hard drive

After you finish

Install a 2.5-inch hard drive into a 3.5-inch hard drive adapter.

Installing a 2.5-inch hard drive into a 3.5-inch hard drive adapter

Before you begin

CAUTION Many repairs may only be done by a certified service technician. You should only perform troubleshooting and simple repairs as authorized in your product documentation, or as directed by the online or telephone service and support team. Damage due to servicing that is not authorized by Dell is not covered by your warranty. Read and follow the safety instructions that are shipped with your product.

1. Follow the safety guidelines listed in the Safety instructions section.
2. Keep the Phillips #2 screwdriver ready.
3. Remove a 3.5-inch hot swappable hard drive adapter from a 3.5-inch hot swappable hard drive carrier.

Procedure

1. Align the screw holes on the 2.5-inch hard drive with the screw holes on the 3.5-inch hard drive adapter.
2. Install the screws to secure the hard drive to the 3.5-inch hard drive adapter.

Figure 39 Installing a 2.5-inch hard drive into a 3.5-inch hard drive adapter

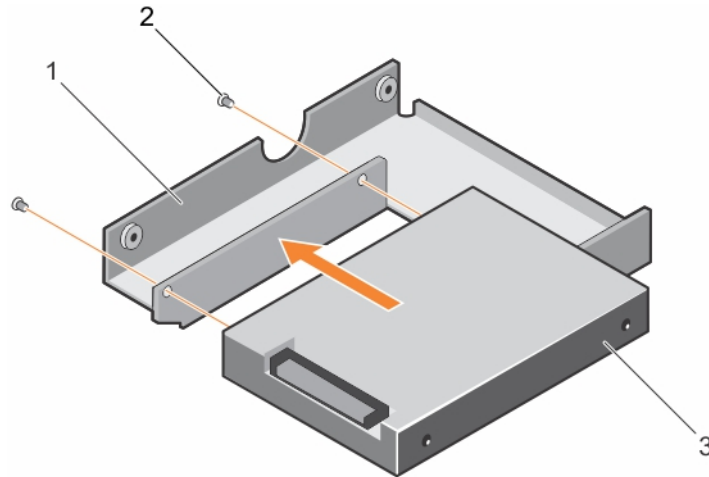

- a. 3.5-inch hard drive adapter
- b. screw (2)
- c. 2.5-inch hard drive

After you finish

Install the 3.5-inch adapter into the 3.5-inch hard drive carrier.

Removing a hard drive from a hard drive carrier

Before you begin

1. Keep the Phillips #1 screwdriver ready.
2. Remove the hot swappable hard drive carrier from the system.

Procedure

1. Remove the screws from the slide rails on the hard drive carrier.
2. Lift the hard drive out of the hard drive carrier.

Figure 40 Removing a hard drive into a hard drive carrier

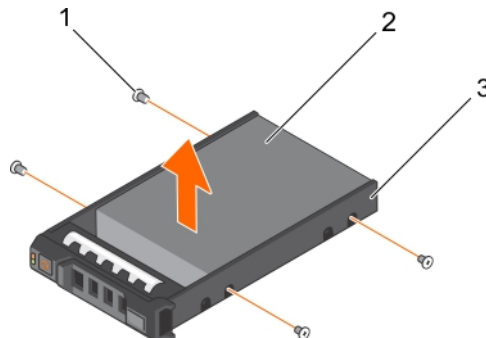

Figure 40 Removing a hard drive into a hard drive carrier (continued)

- a. screw (4)
- b. hard drive
- c. hard drive carrier

Installing a hard drive into a hard drive carrier

Before you begin

CAUTION Many repairs may only be done by a certified service technician. You should only perform troubleshooting and simple repairs as authorized in your product documentation, or as directed by the online or telephone service and support team. Damage due to servicing that is not authorized by Dell is not covered by your warranty. Read and follow the safety instructions that are shipped with your product.

Procedure

1. Insert the hard drive into the hard drive carrier with the connector end of the hard drive toward the back of the carrier.
2. Align the screw holes on the hard drive with the screws holes on the hard drive carrier.
When aligned correctly, the back of the hard drive is flush with the back of the hard drive carrier.
3. Attach the screws to secure the hard drive to the hard drive carrier.

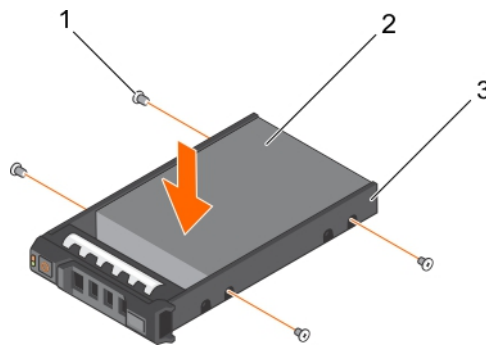
Figure 41 Installing a hard drive into a hard drive carrier

- a. screw (4)
- b. hard drive
- c. hard drive carrier

After you finish

Install the hot swappable hard drive carrier.

Optical drive (optional)

Optical drives retrieve and store data on optical discs such as CD and DVD. Optical drives can be categorized into two basic types: optical disc readers and optical disc writers.

Removing the optional ultra slim optical drive

The procedure for removing an optical drive and optical drive blank is the same.

Before you begin

CAUTION Many repairs may only be done by a certified service technician. You should only perform troubleshooting and simple repairs as authorized in your product documentation, or as directed by the online or telephone service and support team. Damage due to servicing that is not authorized by Dell is not covered by your warranty. Read and follow the safety instructions that are shipped with your product.

1. Follow the safety guidelines listed in the Safety instructions section.
2. Follow the procedure listed in the Before working inside your system section.

Note: Observe the routing of the power and data cables inside the chassis as you remove them from the system board and the optical drive. Route these cables in the same way when you replace them to prevent them from being pinched or crimped.

Procedure

1. Disconnect the power and data cables from the back of the optical drive.
2. If required, disconnect the power and data cables from the system board.
3. To release the optical drive, press and push the release tab toward the front of the system.
4. Slide the optical drive out of the system.

Figure 42 Removing the ultra slim optical drive

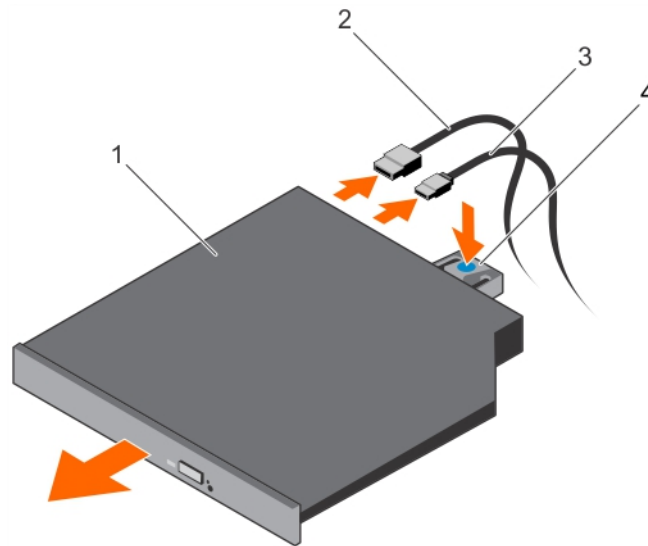



- a. optical drive
- b. data cable
- c. power cable

Figure 42 Removing the ultra slim optical drive (continued)

d. release tab

After you finish

1. If you are not installing an optical drive immediately, install an optical drive blank.
 -  **Note:** Blanks must be installed on empty optical drive or tape drive slots to maintain FCC certification of the system. The brackets also keep dust and dirt out of the system and aid in proper cooling and airflow inside the system.
 -  **Note:** The procedure to install an optical drive blank is similar to the procedure to install an optical drive.
2. Follow the procedure listed in the After working inside your system section.

Installing the optional ultra slim optical drive

The procedure for installing an optical drive and optical drive blank is similar to the procedure to install an optical drive.

Before you begin

 **CAUTION** Many repairs may only be done by a certified service technician. You should only perform troubleshooting and simple repairs as authorized in your product documentation, or as directed by the online or telephone service and support team. Damage due to servicing that is not authorized by Dell is not covered by your warranty. Read and follow the safety instructions that are shipped with your product.

1. Follow the safety guidelines listed in the Safety instructions section.
2. Follow the procedure listed in the Before working inside your system section.
3. If installed, remove the optical drive blank by pressing the blue release tab at the back of the blank and pushing the blank out of the system.

Procedure

1. Align the optical drive with the optical drive slot on the front of the chassis.
2. Slide the optical drive into the slot until the latch snaps into place.
3. Connect the power and data cables to the back of the optical drive.
4. Route the power and data cables through the cable routing latch of the system.
5. Connect the power and data cables to the connectors on the system board.

Figure 43 Installing the ultra slim optical drive

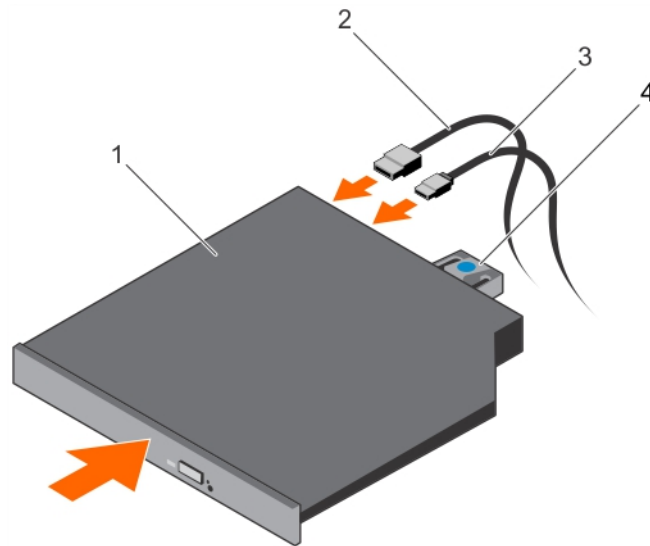

- a. optical drive
- b. data cable
- c. power cable
- d. release tab

After you finish

Follow the procedure listed in the After working inside your system section.

Removing the standard optical drive

Before you begin

CAUTION Many repairs may only be done by a certified service technician. You should only perform troubleshooting and simple repairs as authorized in your product documentation, or as directed by the online or telephone service and support team. Damage due to servicing that is not authorized by Dell is not covered by your warranty. Read and follow the safety instructions that are shipped with your product.

1. Follow the safety guidelines listed in the Safety instructions section.
2. Follow the procedure listed in the Before working inside your system section.

Procedure

1. Disconnect the power and data cable from the back of the optical drive.
Observe the routing of the power and data cable inside the chassis as you remove them from the system board and the drive. You must route these cables properly when you replace them to prevent them from being pinched or crimped.
2. Pull the release latch and disengage the optical drive from the notches on the metal standoffs.
3. Lift the optical drive out of the system.
4. If you are not adding a new optical drive, install the optical-drive blank.

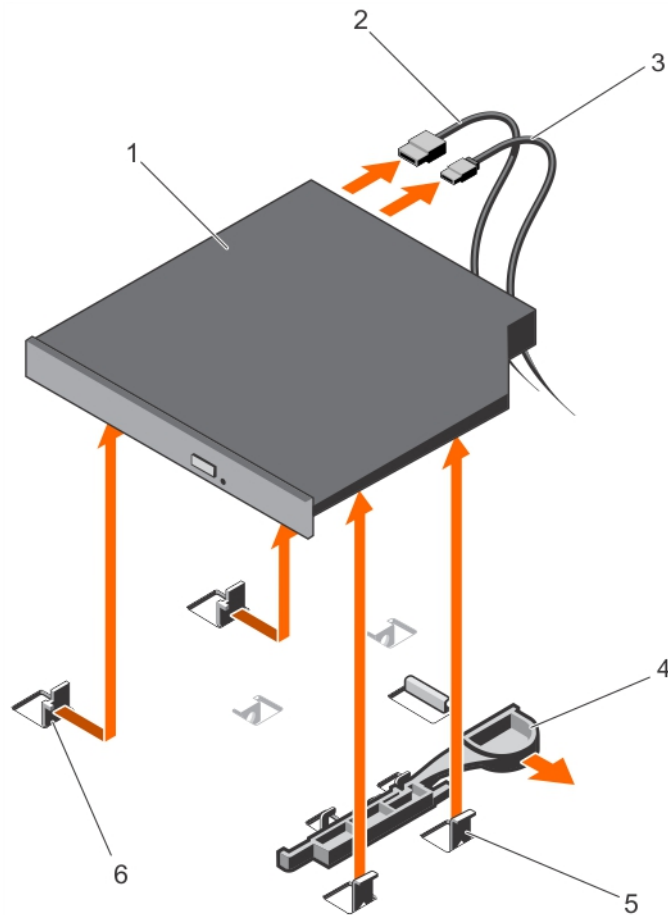
Figure 44 Removing the standard optical drive

- a. optical drive
- b. data cable
- c. power cable
- d. release latch
- e. metal standoff (4)
- f. notch on the metal standoff (2)

After you finish

Follow the procedure listed in the After working inside your system section.

Installing the standard optical drive**Before you begin**

CAUTION Many repairs may only be done by a certified service technician. You should only perform troubleshooting and simple repairs as authorized in your product documentation, or as directed by the online or telephone service and support team. Damage due to servicing that is not authorized by Dell is not covered by your warranty. Read and follow the safety instructions that are shipped with your product.

1. Follow the safety guidelines listed in the Safety instructions section.
2. Follow the procedure listed in the Before working inside your system section.

Procedure

1. Align the two notches on the metal standoffs with the slots on the side of the optical drive.
2. Slide the optical drive into the notches until it is seated firmly and the release latch snaps into place.
3. Connect the power cable.
4. Connect the data cable to the back of the drive and to the SATA connector on the system board.

Note: Route and secure the cables using the cable routing latch on the system chassis to prevent them from being pinched or crimped.

Figure 45

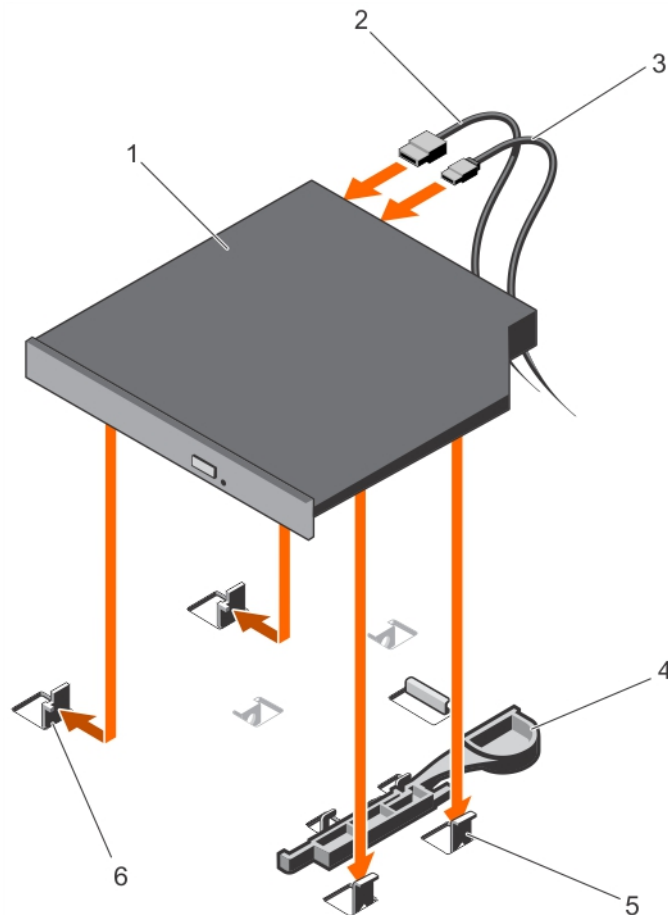

- a. optical drive
- b. data cable
- c. power cable
- d. release latch
- e. metal standoff (4)
- f. notch on the metal standoff (2)

After you finish

Follow the procedure listed in the After working inside your system section.

Cooling fans

Your system supports:

- Up to four cooling fans in a non-redundant power supply unit (PSU) configuration.
- Up to five cooling fans in a redundant PSU configuration.

Note: Fan 1 must be installed in a redundant PSU configuration.

Note: Hot-swap removal or installation of the fans is not supported.

Note: Each fan is listed in the systems management software, referenced by the respective fan number. If there is a problem with a particular fan, you can easily identify and replace the proper fan by noting the fan numbers on the cooling fan assembly.

Removing a cooling fan

Before you begin

CAUTION Many repairs may only be done by a certified service technician. You should only perform troubleshooting and simple repairs as authorized in your product documentation, or as directed by the online or telephone service and support team. Damage due to servicing that is not authorized by Dell is not covered by your warranty. Read and follow the safety instructions that are shipped with your product.

Note: The procedure for removing each fan is identical.

1. Follow the safety guidelines listed in the Safety instructions section.
2. Follow the procedure listed in the Before working inside your system section.
3. Remove the cooling shroud.

Procedure

1. Disconnect the power cable from the power connector on the system board or power interposer board.
2. Lift the fan out of the cooling fan bracket.

Figure 46 Removing a cooling fan

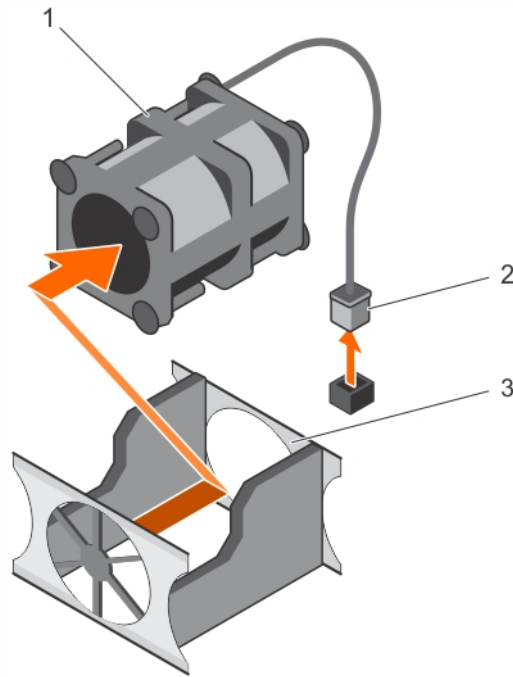

- a. cooling fan
- b. power cable connector
- c. cooling fan bracket

After you finish

1. Install the cooling fan.
2. Follow the procedure listed in the After working inside your system section.

Installing a cooling fan

Before you begin

CAUTION Many repairs may only be done by a certified service technician. You should only perform troubleshooting and simple repairs as authorized in your product documentation, or as directed by the online or telephone service and support team. Damage due to servicing that is not authorized by Dell is not covered by your warranty. Read and follow the safety instructions that are shipped with your product.

Note: The procedure for installing each fan is identical.

1. Follow the safety guidelines listed in the Safety instructions section.
2. Follow the procedure listed in the Before working inside your system section.
3. Remove the cooling shroud.
4. If installed, remove the cooling fan blank.

Procedure

1. Lower the fan into the cooling fan bracket.
2. Connect the power cable to the power cable connector on the system board.

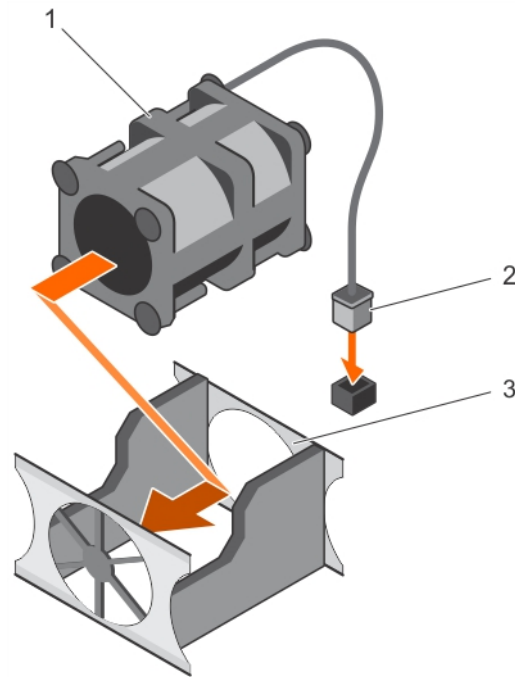
Figure 47 Installing a cooling fan

- a. cooling fan
- b. power cable connector
- c. cooling fan bracket

After you finish

1. Install the cooling shroud.
2. Follow the procedure listed in the After working inside your system section.

Internal USB memory key (optional)

An optional USB memory key installed inside your system can be used as a boot device, security key, or mass storage device.

To boot from the USB memory key, configure the USB memory key with a boot image and then specify the USB memory key in the boot sequence in System Setup.

The internal USB port must be enabled in **Internal USB Port** option in the **Integrated Devices** screen of **System Setup**.

The internal USB port is located on the system board.

Note: To locate the internal USB port (INT_USB) on the system board, see the System board connectors section.

Replacing the optional internal USB memory key

Before you begin

CAUTION Many repairs may only be done by a certified service technician. You should only perform troubleshooting and simple repairs as authorized in your product documentation, or as directed by the online or telephone service and support team. Damage due to servicing that is

not authorized by Dell is not covered by your warranty. Read and follow the safety instructions that are shipped with your product.

1. Follow the safety guidelines listed in the Safety instructions section.
2. Follow the procedure listed in the Before working inside your system section.

Procedure

1. Locate the USB port or USB memory key on the system board.
To locate the USB port, see the System board connectors section.
2. If installed, remove the USB memory key from the USB port.

Figure 48 Removing the internal USB memory key

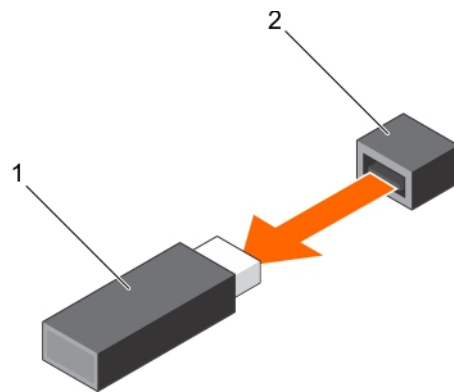

- a. USB memory key
- b. USB port

3. Insert the replacement USB memory key into the USB port.

Figure 49 Installing the internal USB memory key

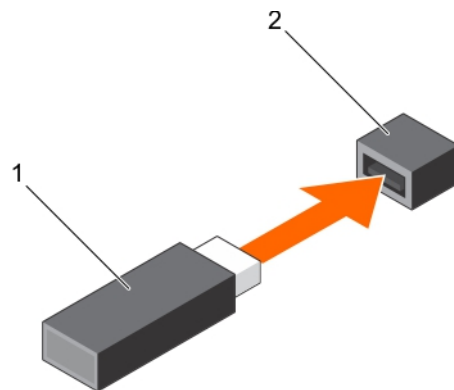

- a. USB memory key
- b. USB port

After you finish

1. Follow the procedure listed in the After working inside your system section.
2. While booting, press F2 to enter System Setup and verify that the system detects the USB memory key.

Expansion cards and expansion card riser

An expansion card in the server is an add-on card that can be inserted into an expansion slot on the system board or riser card to add enhanced functionality to the system through the expansion bus.

Note: A System Event Log (SEL) event is logged if an expansion card riser is unsupported or missing. It does not prevent your system from turning on and no BIOS POST message or F1/F2 pause is displayed.

Expansion card installation guidelines

Your system supports Generation 1, Generation 2, and Generation 3 cards. The following table provides riser configurations for R430 systems:

This table describes about the Expansion card slots available on the expansion-card riser.

Table 40 Expansion card slots available on the expansion-card riser

Expansion-card riser	PCIe slot on the expansion-card riser	Processor connection	Height	Length	Link width	Slot width
PCIE_G3_X16	1	Processor 1	Half Height	Half Length	x16	x16
	2	Processor 1	Half Height	Half Length	x16	x16
PCIE_G3_X8	1	Processor 1	Full Height	Half Length	x8	x16
	2	Processor 1	Half Height	Half Height	x8	x16

Note: The PCIE_G3_X8 and PCIE_G3_X16 are the two different types of risers supported on R430 systems. You can install an expansion card on the system board only using expansion-card riser.

Note: The expansion cards are not hot-swappable.

The following table provides a guide for installing expansion cards to ensure proper cooling and mechanical fit. The expansion cards with the highest priority must be installed first using the slot priority indicated. All other expansion cards must be installed in card priority and slot priority order.

This table describes about the Expansion card installation order (Low Profile + Low Profile configuration)

Table 41 Expansion card installation order (Low Profile + Low Profile configuration)

Card priority	Card type	Slot priority	Maximum allowed
1	RAID Integrated Storage	Integrated Slot	1
	RAID External Storage	2, 1	1
2	Infiniband single Port/Dual (Mellanox)	2, 1	2

Table 41 Expansion card installation order (Low Profile + Low Profile configuration) (continued)

Card priority	Card type	Slot priority	Maximum allowed
3	40 Gb NICs	2, 1	2
4	10 Gb NICs	2, 1	2
5	FC8 HBA	2, 1	2
6	1 Gb NICs	2, 1	2
7	12 GB SAS HBA	2, 1	2
	HBA330	Integrated Slot	1

This table describes about the Expansion card installation order (Full Height +Low Profile configuration)

Table 42 Expansion card installation order (Full Height +Low Profile configuration)

Card priority	Card type	Slot priority	Maximum allowed
1	RAID Integrated Storage	Integrated Slot	1
	RAID External Storage Low Profile	2	1
	RAID External Storage Full Height	1	1
2	Infiniband Single Port/Dual Port (Mellanox)	2	1
3	40 Gb NICs (Low profile)	2	1
	40 Gb NICs (Full height)	1	1
4	10 Gb NICs (Low profile)	2	1
	10 Gb NICs (Full height)	1	1
5	FC8 HBA (Low profile)	2	1
	FC8 HBA (Full height)	1	1
6	1 Gb NICs (Low profile)	2	1
	1 Gb NICs (Full height)	1	1
7	12 GB-SAS-HBA (Low profile)	2	1
	12 GB-SAS-HBA (Full height)	1	1
8	Non-RAID HBA330	Integrated Slot	1

Removing the expansion card riser

Before you begin

 **CAUTION** Many repairs may only be done by a certified service technician. You should only perform troubleshooting and simple repairs as authorized in your product documentation, or as

directed by the online or telephone service and support team. Damage due to servicing that is not authorized by Dell is not covered by your warranty. Read and follow the safety instructions that are shipped with your product.

1. Follow the safety guidelines listed in Safety instructions section.
2. Follow the procedure listed in the Before working inside your system section.

Procedure

1. Holding the touch points, lift the expansion card riser from the riser connector on the system board.

Figure 50 Removing and installing the expansion card riser

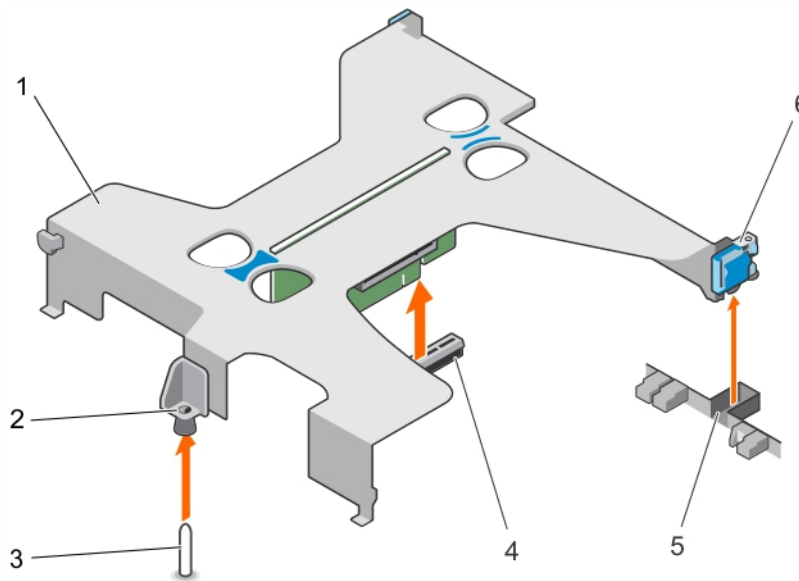

- a. expansion card riser
- b. guide on the expansion card riser
- c. guide pin on the system board
- d. riser connector on the system board
- e. slot on the chassis
- f. expansion card latch

After you finish

1. Install the expansion card riser.
2. Follow the procedure listed in the After working inside your system section.

Installing the expansion card riser

Before you begin

CAUTION Many repairs may only be done by a certified service technician. You should only perform troubleshooting and simple repairs as authorized in your product documentation, or as directed by the online or telephone service and support team. Damage due to servicing that is not authorized by Dell is not covered by your warranty. Read and follow the safety instructions that are shipped with your product.

1. Follow the safety guidelines listed in the Safety instructions section.

2. Follow the procedure listed in the Before working inside your system section.
3. Install the expansion card into the expansion card riser.

Procedure

1. Align the following:
 - a. guide on the expansion-card riser with the guide pin on the system board.
 - b. expansion card riser latch with the slot on the chassis.
2. Lower the expansion card riser until the expansion card riser is firmly seated in the connector on the system board.
3. Close the expansion card riser latch.

Figure 51 Installing the expansion card riser

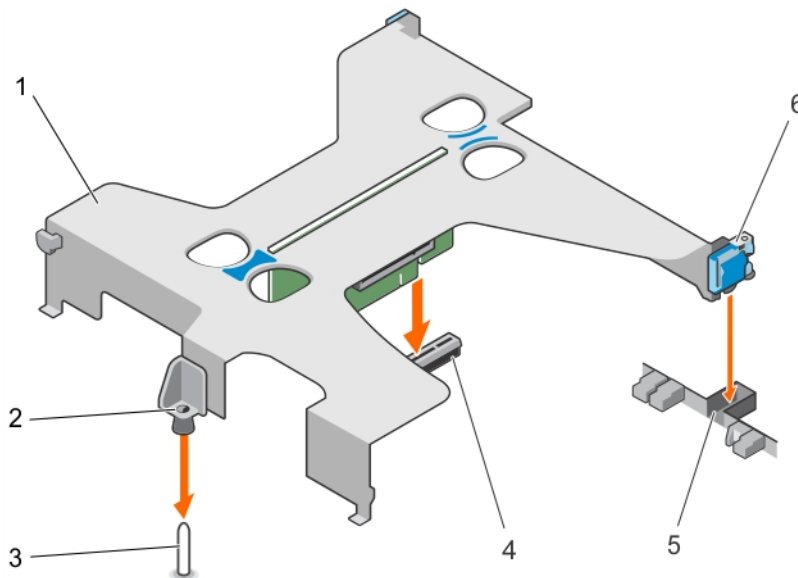

- a. expansion card riser
- b. guide on the expansion card riser
- c. guide pin on the system board
- d. riser connector on the system board
- e. slot on the chassis
- f. expansion card latch

After you finish

Follow the procedure listed in the After working inside your system section.

Removing an expansion card

Before you begin

CAUTION Many repairs may only be done by a certified service technician. You should only perform troubleshooting and simple repairs as authorized in your product documentation, or as directed by the online or telephone service and support team. Damage due to servicing that is not authorized by Dell is not covered by your warranty. Read and follow the safety instructions that are shipped with your product.

1. Follow the safety guidelines listed in the Safety instructions section.
2. Follow the procedure listed in the Before working inside your system section.
3. Disconnect any cables connected to the expansion card or expansion card riser.
4. If installed, remove the expansion card riser.

Procedure

1. Hold the expansion card by its edges and remove it from the expansion card riser connector.
2. If you are removing the card permanently, install a filler bracket in the empty expansion card slot and close the expansion card latch.

Note: You must install a filler bracket over an empty expansion card slot to maintain Federal Communications Commission (FCC) certification of the system. The brackets also keep dust and dirt out of the system and aid in proper cooling and airflow inside the system.

Figure 52 Removing an expansion card from the expansion card riser

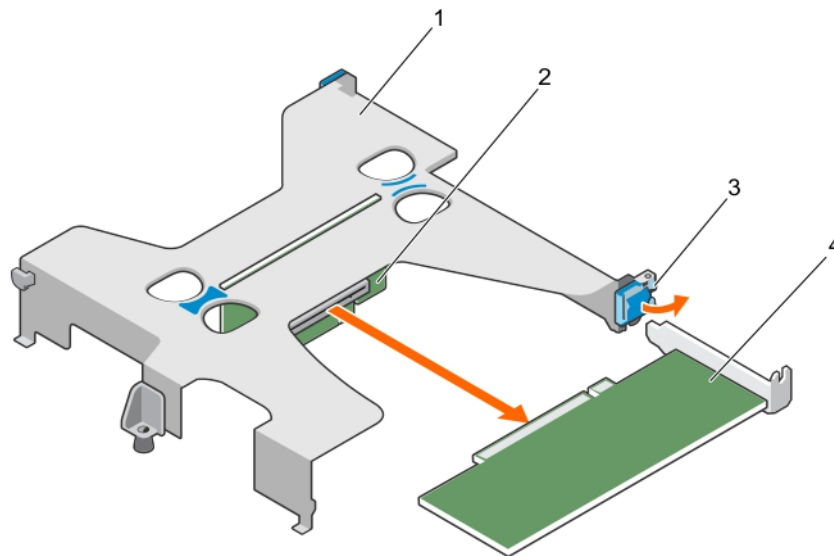

- a. expansion card riser
- b. expansion card riser connector
- c. expansion card latch
- d. expansion card

After you finish

1. Install the expansion card.
2. Install the expansion card riser
3. Follow the procedure listed in the After working inside your system section.

Installing an expansion card

Before you begin

CAUTION Many repairs may only be done by a certified service technician. You should only perform troubleshooting and simple repairs as authorized in your product documentation, or as directed by the online or telephone service and support team. Damage due to servicing that is

not authorized by Dell is not covered by your warranty. Read and follow the safety instructions that are shipped with your product.

1. Follow the safety guidelines listed in the Safety instructions section.
2. Follow the procedure listed in the Before working inside your system section.
3. Remove the expansion card riser.

Procedure

1. Locate the expansion card connector on the riser.
2. Holding the expansion card by its edges, position the card so that the card connector aligns with the connector on the expansion card riser.
3. Align the expansion card bracket with the hooks on the chassis.
4. Insert the card connector into the expansion card riser connector until the card is firmly seated.

Note: Ensure that the expansion card is properly seated along the chassis, so that expansion card latch can be closed.

5. If required, connect the cables to the expansion card.

Figure 53 Installing an expansion card into the expansion card riser

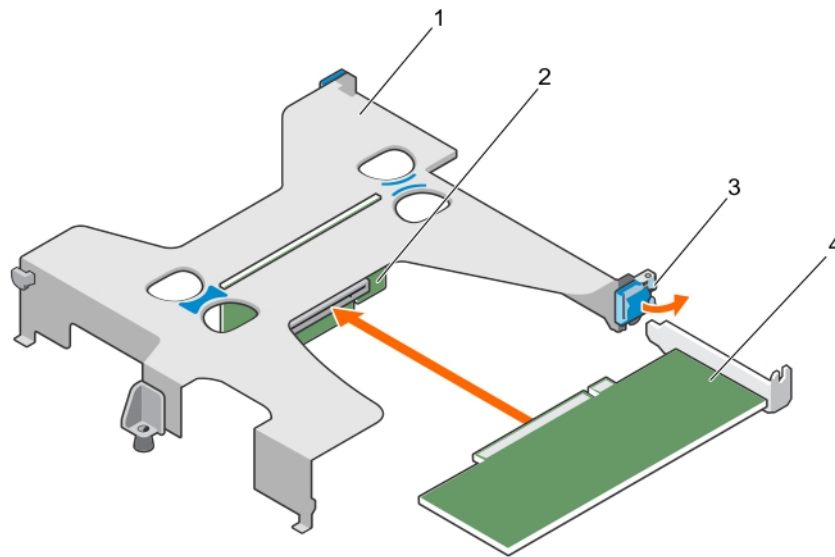

- a. expansion card riser
- b. expansion card riser connector
- c. expansion card latch
- d. expansion card

After you finish

1. Install the expansion card riser.
2. Follow the procedure listed in the After working inside your system section.

iDRAC port card (optional)

The iDRAC port card consists of a SD vFlash card slot and an iDRAC port. The iDRAC port card is used for advanced management of the system. An SD vFlash card is a Secure Digital (SD) card

that plugs into the SD vFlash card slot in the system. It provides persistent on-demand local storage and a custom deployment environment that allows automation of server configuration, scripts, and imaging. It emulates USB device(s). For more information, see the Integrated Dell Remote Access Controller User's Guide at Dell.com/esmmanuals.

The iDRAC port card consists of the SD vFlash card slot and an iDRAC port. The iDRAC port card features a dedicated NIC port and is used for remote, advanced management of the system through the network.

An SD vFlash card is a Secure Digital (SD) card that plugs into the SD vFlash card slot in the iDRAC port card. It provides persistent on-demand local storage and a custom deployment environment that enables automation of server configuration, scripts, and imaging. It emulates a USB device. For more information, see the Integrated Dell Remote Access Controller User's Guide at Dell.com/idracmanuals.

Removing the optional iDRAC port card

Before you begin

 **CAUTION** Many repairs may only be done by a certified service technician. You should only perform troubleshooting and simple repairs as authorized in your product documentation, or as directed by the online or telephone service and support team. Damage due to servicing that is not authorized by Dell is not covered by your warranty. Read and follow the safety instructions that are shipped with your product.

1. Follow the safety guidelines listed in the Safety instructions section.
2. Follow the procedure listed in the Before working inside your system section.
3. Keep the Phillips #2 screwdriver ready.
4. If connected, disconnect the network cable from the iDRAC port card.
5. If installed, remove the expansion card riser.
6. Remove the cooling shroud.

Procedure

1. Loosen the screws securing the iDRAC port card holder to the system board.
2. Pull the iDRAC port card to disengage it from the iDRAC port card connector on the system board, and remove the card from the chassis.

Figure 54 Removing the iDRAC port card

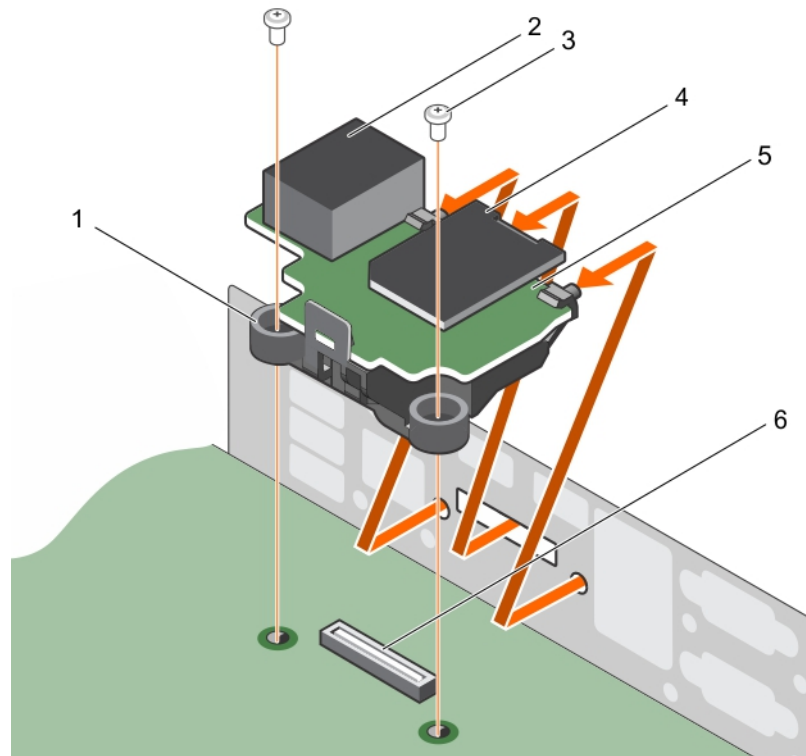

- a. iDRAC port card holder
- b. iDRAC port
- c. screw (2)
- d. SD vFlash media card
- e. iDRAC port card
- f. iDRAC port card connector

After you finish

1. Install the iDRAC port card.
2. Install the expansion card riser.
3. Install the cooling shroud.
4. If disconnected, reconnect the network cable.
5. Follow the procedure listed in the After working inside your system section.

Installing the optional iDRAC port card

Before you begin

CAUTION Many repairs may only be done by a certified service technician. You should only perform troubleshooting and simple repairs as authorized in your product documentation, or as directed by the online or telephone service and support team. Damage due to servicing that is not authorized by Dell is not covered by your warranty. Read and follow the safety instructions that are shipped with your product.

1. Ensure that you follow the safety guidelines listed in the Safety instructions section.

2. Follow the procedure listed in the Before working inside your system section.
3. Keep the Phillips #2 screwdriver ready.
4. Remove the cooling shroud.
5. If installed, remove the expansion card riser.

Procedure

1. Align and insert the tabs on the iDRAC port card into the slots on the chassis.
2. Insert the iDRAC port card into the connector on the system board.
3. Tighten the screws that secure the iDRAC port card holder to the system board.

Figure 55 Installing the iDRAC port card

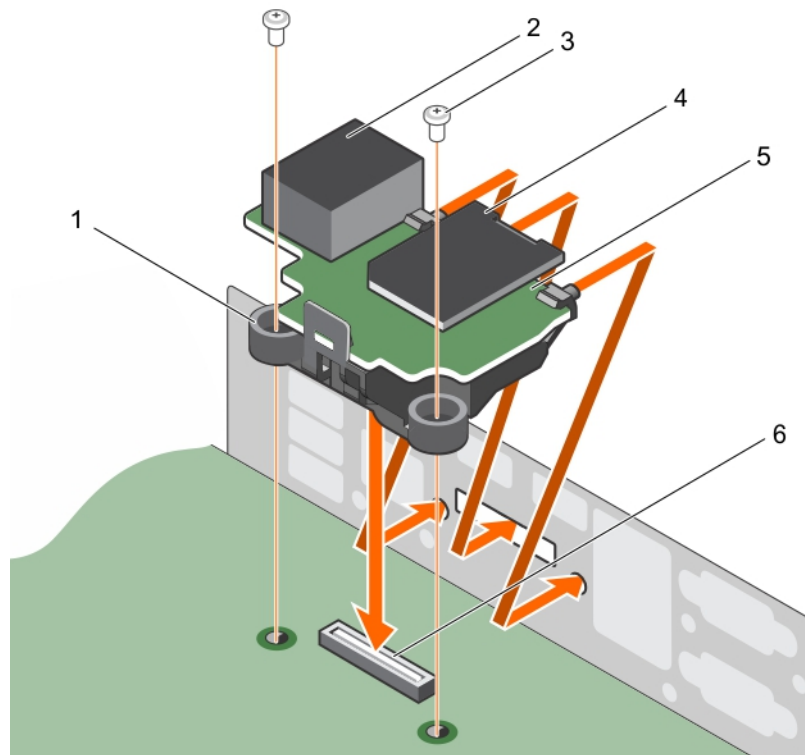

- a. iDRAC port card holder
- b. iDRAC port
- c. screw (2)
- d. SD vFlash media card
- e. iDRAC port card
- f. iDRAC port card connector

After you finish

1. Install the expansion card riser.
2. Install the cooling shroud.
3. If disconnected, reconnect the network cable.
4. Follow the procedure listed in the After working inside your system section.

SD vFlash card (optional)

An SD vFlash card is a Secure Digital (SD) card that plugs into the SD vFlash card slot in the iDRAC port card. It provides persistent on-demand local storage and a custom deployment environment that enables automation of server configuration, scripts, and imaging. It emulates USB device(s). For more information, see the Integrated Dell Remote Access Controller User's Guide at Dell.com/idracmanuals.

Removing the optional SD vFlash card

Before you begin

1. Follow the safety guidelines listed in the Safety instructions section.
2. Locate the SD vFlash card slot at the back of the chassis.

Procedure

1. To remove the SD vFlash card, push the SD vFlash card inward to release it, and pull the SD vFlash card from the SD vFlash card slot.

Figure 56 Removing the optional SD vFlash card

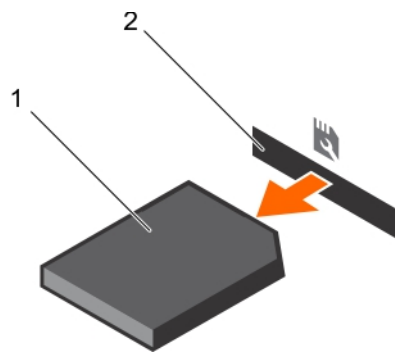

- a. SD vFlash card
- b. SD vFlash card slot

Installing an optional SD vFlash card

Before you begin

1. Follow the safety guidelines listed in the Safety instructions section.
2. Locate the SD vFlash card slot at the back of the chassis.

Procedure

1. Install a the SD vFlash card by inserting the contact-pin end of the SD vFlash card into the SD vFlash card slot on the iDRAC port card module.

Note: The slot is keyed to ensure correct insertion of the SD vFlash card.

2. Press the SD vFlash card inward to lock it into the SD vFlash card slot.

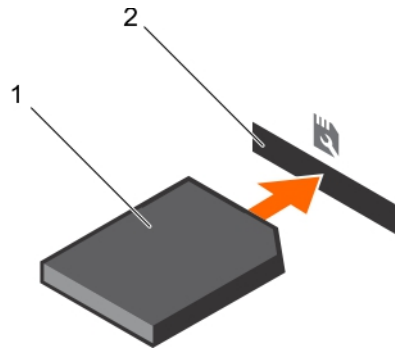
Figure 57 Installing an optional SD vFlash card

Internal dual SD module (optional)

The Internal Dual SD Module (IDSDM) card provides two SD card slots. This card offers the following features:

- Dual card operation — maintains a mirrored configuration by using SD cards in both the slots and provides redundancy.
 - ① **Note:** When the **Redundancy** option is set to **Mirror Mode** in the **Integrated Devices** screen of System Setup, the information is replicated from one SD card to another.
- Single card operation — single card operation is supported, but without redundancy.

Removing an internal SD card

Before you begin

1. Follow the safety guidelines listed in the Safety instructions section.
2. Follow the procedure listed in the Before working inside your system section.

⚠ CAUTION Many repairs may only be done by a certified service technician. You should only perform troubleshooting and simple repairs as authorized in your product documentation, or as directed by the online or telephone service and support team. Damage due to servicing that is not authorized by Dell is not covered by your warranty. Read and follow the safety instructions that are shipped with your product.

① **Note:** Temporarily label each SD card with its corresponding slot number before removal. Reinstall the SD card(s) into the corresponding slots.

Procedure

1. Locate the SD card slot on the internal dual SD module and press the card to release it from the slot.

Figure 58 Removing an internal SD card

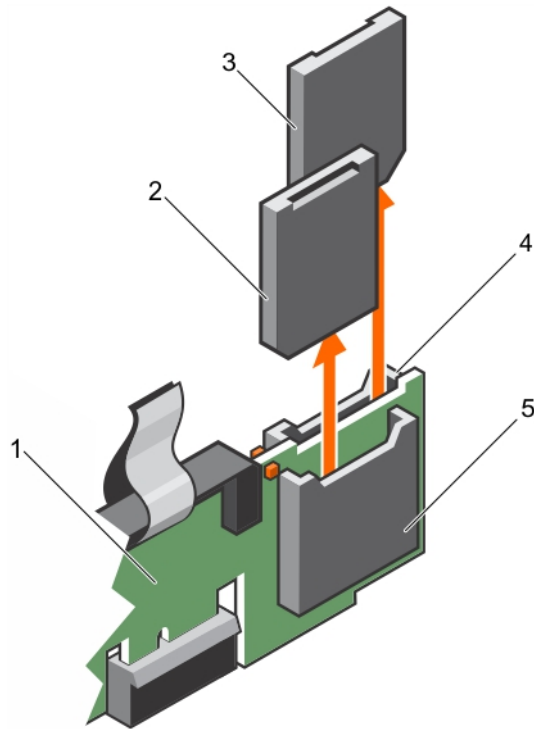

- a. IDSDM
- b. SD card 1
- c. SD card 2
- d. SD card slot 2
- e. SD card slot 1

After you finish

Follow the procedure listed in the After working inside your system section.

Installing an internal SD card

Before you begin

1. Follow the safety guidelines listed in the Safety instructions section.
2. Follow the procedure listed in the Before working inside your system section.

CAUTION Many repairs may only be done by a certified service technician. You should only perform troubleshooting and simple repairs as authorized in your product documentation, or as directed by the online or telephone service and support team. Damage due to servicing that is not authorized by Dell is not covered by your warranty. Read and follow the safety instructions that are shipped with your product.

Note: To use an SD card with your system, ensure that the **Internal SD Card Port** is enabled in System Setup.

Note: Temporarily label each SD card with its corresponding slot number before removal. Re-install the SD card(s) into the corresponding slots.

Procedure

1. Locate the SD card connector on the internal dual SD module. Orient the SD card appropriately and insert the contact-pin end of the card into the slot.

Note: The slot is keyed to ensure correct insertion of the card.

2. Press the card into the card slot to lock it into place.

Figure 59 Installing an internal SD card

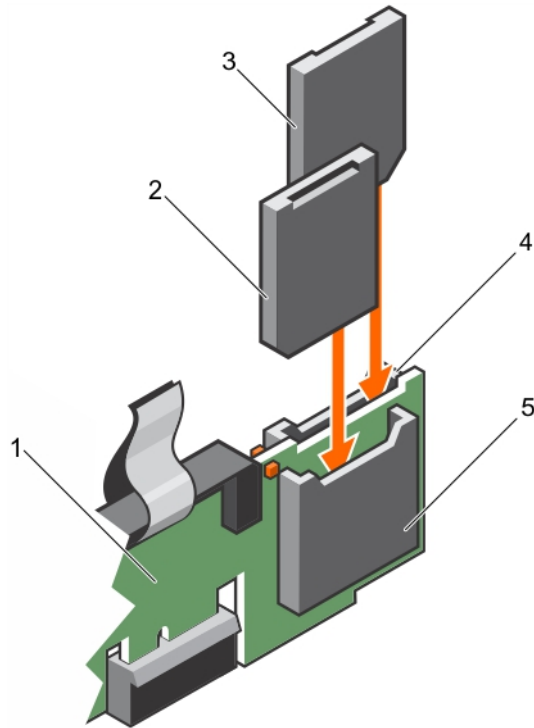

- a. IDSDM
- b. SD card 2
- c. SD card 1
- d. SD card slot 1
- e. SD card slot 2

After you finish

Follow the procedure listed in the After working inside your system section.

Removing the optional internal dual SD module

Before you begin

CAUTION Many repairs may only be done by a certified service technician. You should only perform troubleshooting and simple repairs as authorized in your product documentation, or as directed by the online or telephone service and support team. Damage due to servicing that is not authorized by Dell is not covered by your warranty. Read and follow the safety instructions that are shipped with your product.

1. Follow the safety guidelines listed in the Safety instructions section.

2. Follow the procedure listed in the Before working inside your system section.
3. If installed, remove the SD cards.
 - ⓘ **Note:** Temporarily label each SD card with its corresponding slot number before removal. Reinstall the SD cards into the corresponding slots.

Procedure

1. Locate the internal dual SD module (IDSDM) on the system board. To locate the internal dual SD module connector, see the System board connectors section.
2. Holding the pull tab, lift the IDSDM out of the system.

Figure 60 Removing the internal dual SD module (IDSDM)

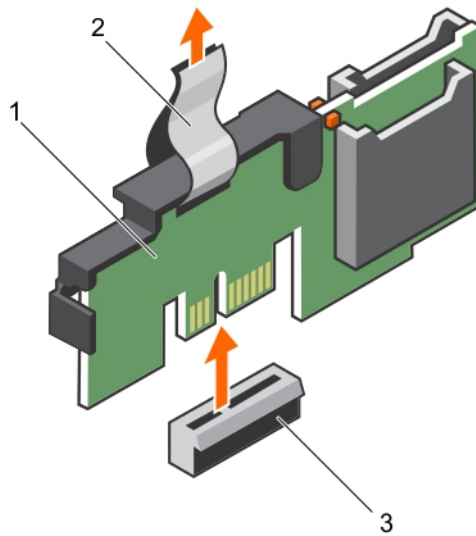

- a. IDSDM
- b. pull tab
- c. IDSDM connector

After you finish

1. Install the IDSDM.
2. If removed, install the SD cards.
3. Follow the procedure listed in the After working inside your system section.

Installing the optional internal dual SD module

Before you begin

⚠ **CAUTION** Many repairs may only be done by a certified service technician. You should only perform troubleshooting and simple repairs as authorized in your product documentation, or as directed by the online or telephone service and support team. Damage due to servicing that is not authorized by Dell is not covered by your warranty. Read and follow the safety instructions that are shipped with your product.

1. Follow the safety guidelines listed in the Safety instructions section.
2. Follow the procedure listed in the Before working inside your system section.
 - ⓘ **Note:** Temporarily label each SD card with its corresponding slot before removal.

Procedure

1. Locate the internal dual SD module (IDSMD) connector on the system board. To locate the IDSMD connector, see the System board connectors section.
2. Align the IDSMD with the connector on the system board.
3. Push the IDSMD until it is firmly seated on the system board.

Figure 61 Installing the optional internal dual SD module

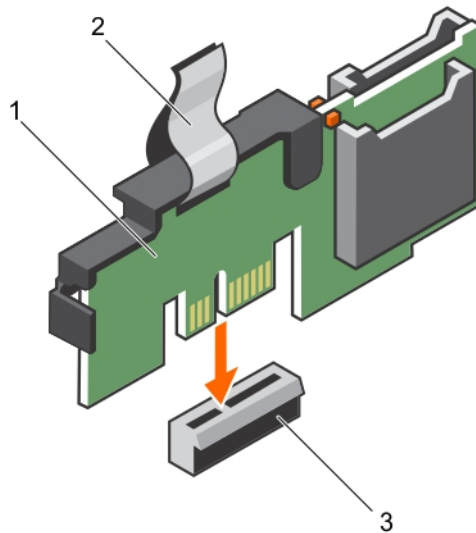

- a. IDSMD
- b. pull tab
- c. IDSMD connector

After you finish

1. Install the SD cards.
 - Note:** Re-install the SD cards into the same slots based on the labels you had marked on the cards during removal.
2. Follow the procedure listed in the After working inside your system section.

Integrated storage controller card

Your system includes a dedicated expansion card slot on the system board for an integrated storage controller card. The integrated storage controller card provides the integrated storage subsystem for the internal hard drives in your system. The controller supports SAS and SATA hard drives and also enables you to set up the hard drives in RAID configurations. The RAID configurations depend on the version of the storage controller included with your system. The controller supports SAS hard drives.

- Note:** The upgrade from embedded controller or Software RAID controller to Hardware RAID controller is not supported.

Removing the integrated storage controller card

Before you begin

CAUTION Many repairs may only be done by a certified service technician. You should only perform troubleshooting and simple repairs as authorized in your product documentation, or as directed by the online or telephone service and support team. Damage due to servicing that is not authorized by Dell is not covered by your warranty. Read and follow the safety instructions that are shipped with your product.

1. Follow the safety guidelines listed in the Safety instructions section.
2. Follow the procedure listed in the Before working inside your system section.
3. Remove the cooling shroud.
4. Keep the Phillips #2 screwdriver ready.

Procedure

1. Loosen the screws that secure the integrated storage controller cable to the integrated storage controller card connector on the system board.
2. Lift the integrated storage controller cable away from the integrated storage controller.
3. Lift one end of the card and angle it to disengage the card from the integrated storage controller card holder on the system board.
4. Lift the card out of the system.

Figure 62 Removing the integrated storage controller card

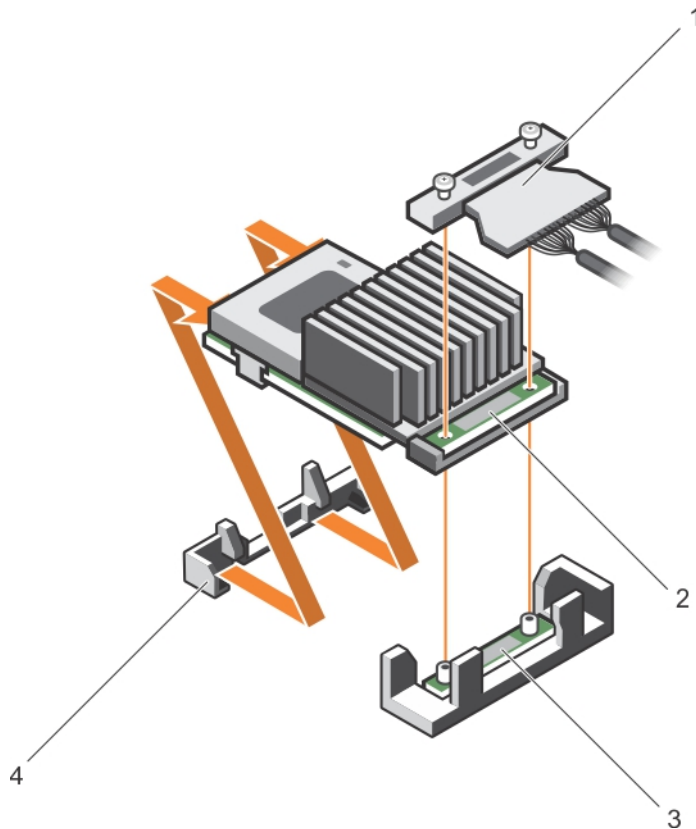

a. integrated storage controller cable

Figure 62 Removing the integrated storage controller card (continued)

- b. integrated storage controller card
- c. integrated storage controller card connector on the system board
- d. integrated storage controller card holder

After you finish

1. Install the cooling shroud.
2. Installing the integrated storage controller card.
3. Follow the procedure listed in the After working inside your system section.

Installing the integrated storage controller card

Before you begin

 **CAUTION** Many repairs may only be done by a certified service technician. You should only perform troubleshooting and simple repairs as authorized in your product documentation, or as directed by the online or telephone service and support team. Damage due to servicing that is not authorized by Dell is not covered by your warranty. Read and follow the safety instructions that are shipped with your product.

1. Follow the safety guidelines listed in the Safety instructions section.
2. Follow the procedure listed in the Before working inside your system section.
3. Remove the cooling shroud.
4. Keep the Phillips #2 screwdriver ready.

Procedure

1. Align the end of the integrated storage controller card with the controller card connector on the system board.
2. Lower the connector side of the integrated storage controller card into the integrated storage controller card connector on the system board.

 **Note:** Ensure that the tabs on the system board align with the screw holes on the integrated storage controller card.

3. Align the screws on the integrated storage controller card cable with the screw holes on the connector.
4. Tighten the screws to secure the integrated storage controller card cable with the integrated storage controller card connector on the system board.

Figure 63 Installing the integrated storage controller card

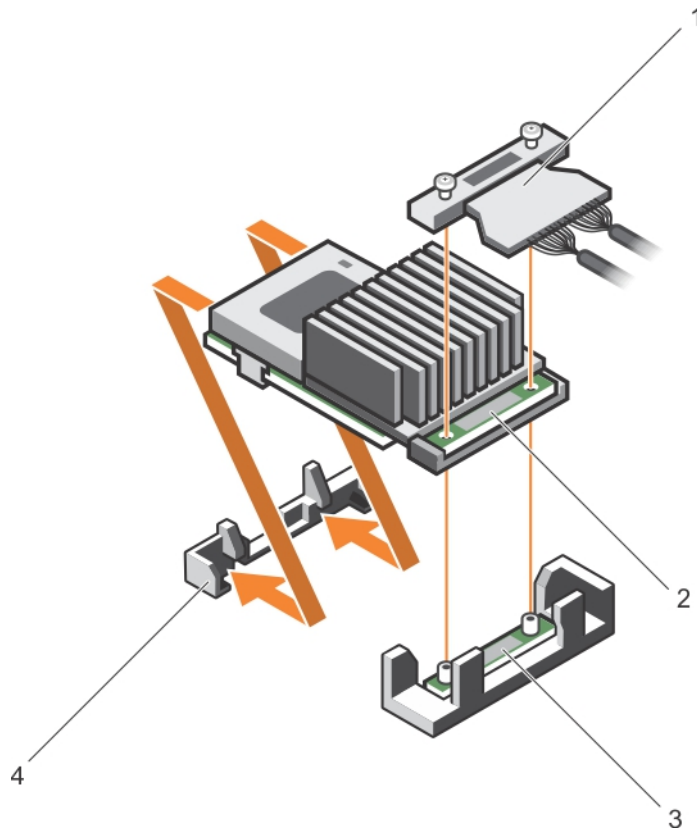

- a. integrated storage controller cable
- b. integrated storage controller card
- c. integrated storage controller card connector on the system board
- d. integrated storage controller card holder

After you finish

1. Install the cooling shroud.
2. Follow the procedure listed in the After working inside your system section.

Processors and heat sinks

Use the following procedure when:

- Removing and installing a heat sink
- Installing an additional processor
- Replacing a processor

Note: To ensure proper system cooling, you must install a processor blank in any empty processor socket.

Removing a heat sink

Before you begin

CAUTION Never remove the heat sink from a processor unless you intend to remove the processor. The heat sink is necessary to maintain proper thermal conditions.

WARNING The heat sink will be hot to touch. Allow the heat sink to cool for some time after powering down the system.

1. Follow the safety guidelines listed in the Safety instructions section.
2. Keep the Phillips #2 screwdriver ready.
3. Follow the procedure listed in the Before working inside your system section.
4. If installed, remove the full-length PCIe card(s).
5. Remove the cooling shroud.

Procedure

1. Loosen one of the screws that secure the heat sink to the system board.
Allow some time (approximately 30 seconds) for the heat sink to loosen from the processor.
2. Remove the screw diagonally opposite the screw you first removed.
3. Repeat the procedure for the remaining two screws.
4. Remove the heat sink.

Figure 64 Removing a heat sink

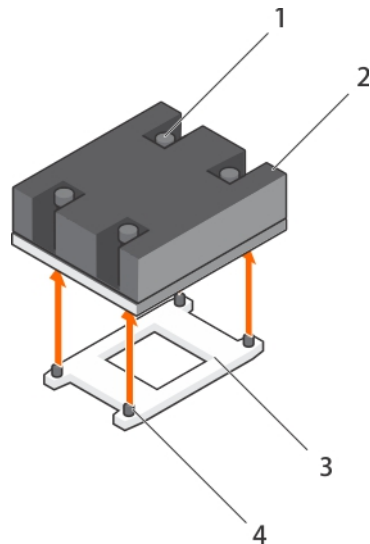

- a. retention screw (4)
- b. heat sink
- c. processor socket
- d. retention screw slot (4)

After you finish

1. Replace the heat sink(s) and processor(s).

2. Follow the procedure listed in the After working inside your system section.

Removing a processor

Before you begin

 **CAUTION** Many repairs may only be done by a certified service technician. You should only perform troubleshooting and simple repairs as authorized in your product documentation, or as directed by the online or telephone service and support team. Damage due to servicing that is not authorized by Dell is not covered by your warranty. Read and follow the safety instructions that are shipped with your product.

 **Note:** This is a Field Replaceable Unit (FRU). Removal and installation procedures should be performed only by Dell certified service technicians.

 **Note:** If you are upgrading your system, download the latest system BIOS version from Dell.com/support and follow the instructions included in the compressed download file to install the update on your system.

 **Note:** You can update the system BIOS by using the Dell Lifecycle Controller.



 **Note:** To ensure proper system cooling, you must install a processor blank in any empty processor socket.

1. Follow the safety guidelines listed in the Safety instructions section.
2. Follow the procedure listed in the Before working inside your system section.
3. Keep the Phillips #2 screwdriver ready.
4. Remove the cooling shroud.
5. Remove the heat sink.

 **WARNING** The processor is hot to touch for some time after the system has been powered down. Allow the processor to cool before removing it.

 **CAUTION** The processor is held in its socket under strong pressure. Be aware that the release lever can spring up suddenly if not firmly grasped.

Procedure

1. Release the *open first* socket lever near the unlock icon  by pushing the lever down and out from under the tab.
2. Release the *close first* socket release lever near the lock icon  by pushing the lever down and out from under the tab. Lift the lever 90 degrees upward.
3. Lower the *open first* socket-release lever to lift the processor shield.
4. Hold the tab on the processor shield and lift the processor shield until the *open first* socket-release lever lifts up.

 **CAUTION** The socket pins are fragile and can be permanently damaged. Be careful not to bend the pins in the socket when removing the processor out of the socket.

5. Lift the processor out of the socket and leave the *open first* socket-release lever up.

 **Note:** If you are permanently removing the processor, you must install a socket protective cap in the vacant socket to protect the socket pins and keep the socket free of dust.

- Note:** After removing the processor, place it in an anti-static container for reuse, return, or temporary storage. Do not touch the bottom of the processor. Touch only the side edges of the processor.

Figure 65 Processor shield

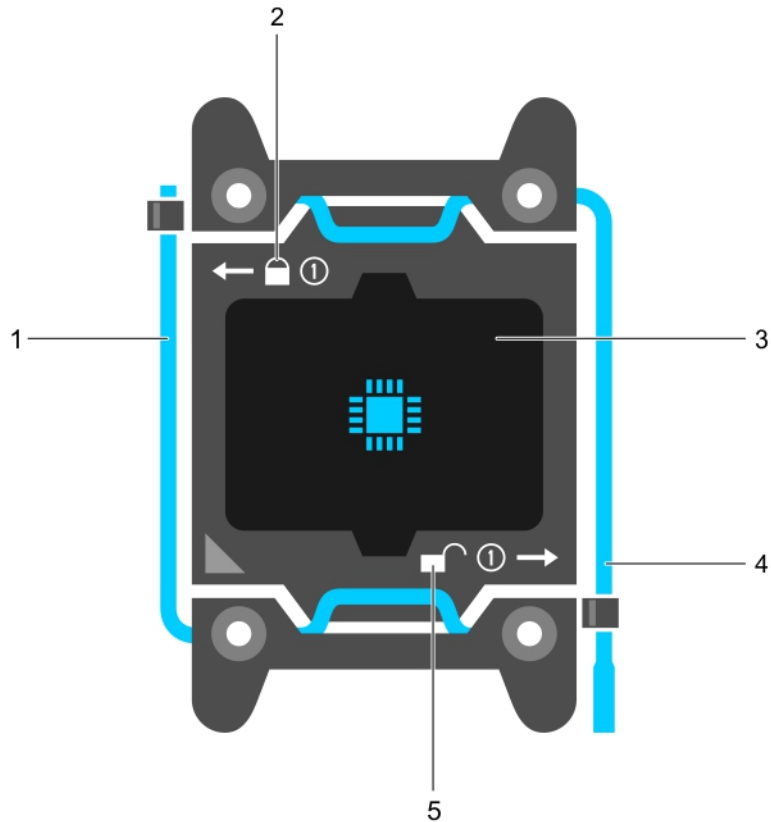

- a. *close first* socket release lever
- b. lock icon
- c. processor
- d. *open first* socket release lever
- e. unlock icon

Figure 66 Removing a processor

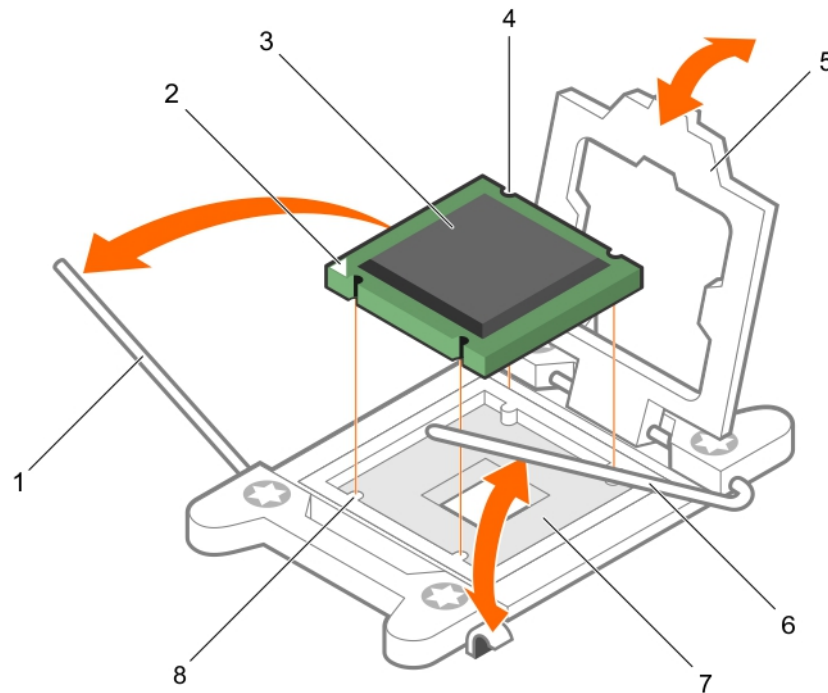

- a. *close first* socket-release lever
- b. pin-1 indicator of processor
- c. processor
- d. slot (4)
- e. processor shield
- f. *open first* socket-release lever
- g. socket
- h. socket keys (4)

After you finish





1. Replace the processor(s).
2. Install the heat sink.
3. Reinstall the cooling shroud.
4. Follow the procedure listed in the After working inside your system section.

Installing a processor







Before you begin

CAUTION Many repairs may only be done by a certified service technician. You should only perform troubleshooting and simple repairs as authorized in your product documentation, or as directed by the online or telephone service and support team. Damage due to servicing that is

not authorized by Dell is not covered by your warranty. Read and follow the safety instructions that are shipped with your product.

1. Follow the safety guidelines listed in the Safety instructions section.
 2. Follow the procedure listed in the Before working inside your system section.
 3. Keep the Phillips #2 screwdriver ready.
 4. If you are upgrading your system, download the latest system BIOS version from [Dell.com/support](https://www.dell.com/support) and follow the instructions included in the compressed download file to install the update on your system.
 -  **Note:** You can also update the system BIOS by using the Dell Lifecycle Controller.
 5. Remove the cooling shroud.
 -  **Note:** If applicable, close the expansion card latch on the cooling shroud to release the full length card.
 6. If connected, disconnect the cables from expansion card(s).
 7. If installed, remove the expansion card riser.
 -  **Note:** The heat sink and processor are too hot to touch for some time after the system has been powered down. Allow the heat sink and processor to cool down before handling them.
-  **CAUTION** Never remove the heat sink from a processor unless you intend to remove the processor. The heat sink is necessary to maintain proper thermal conditions.
-  **Note:** If you are installing a single processor, it must be installed in socket CPU1.

Procedure

1. Unpack the new processor.
 -  **Note:** If the processor has previously been used in a system, remove any remaining thermal grease from the processor by using a lint-free cloth.
2. Locate the processor socket.
3. If applicable, remove the socket protective cap.
4. Release the *open first* socket-release lever near the unlock icon  by pushing the lever down and out from under the tab.
5. Similarly, release the *close first* socket-release lever near the lock icon  by pushing the lever down and out from under the tab. Lift the lever 90 degrees upward.
6. Hold the tab near the lock symbol on the processor shield and lift it up and out of the way.
 -  **CAUTION** Positioning the processor incorrectly can permanently damage the system board or the processor. Be careful not to bend the pins in the socket.
 -  **CAUTION** While removing or reinstalling the processor, wipe your hands of any contaminants. Contaminants on the processor pins such as thermal grease or oil can damage the processor.
7. Align the processor with the socket keys.
 -  **CAUTION** Do not use force to seat the processor. When the processor is positioned correctly, it engages easily into the socket.
8. Align the pin-1 indicator of the processor with the triangle on the socket.
9. Place the processor on the socket such that the slots on the processor align with the socket keys.





10. Close the processor shield.
11. Lower the *close first* socket-release lever near the lock icon  and push it under the tab to lock it.
12. Similarly, lower the *open first* socket-release lever near the unlock icon  and push it under the tab to lock it.

Figure 67 Installing a processor

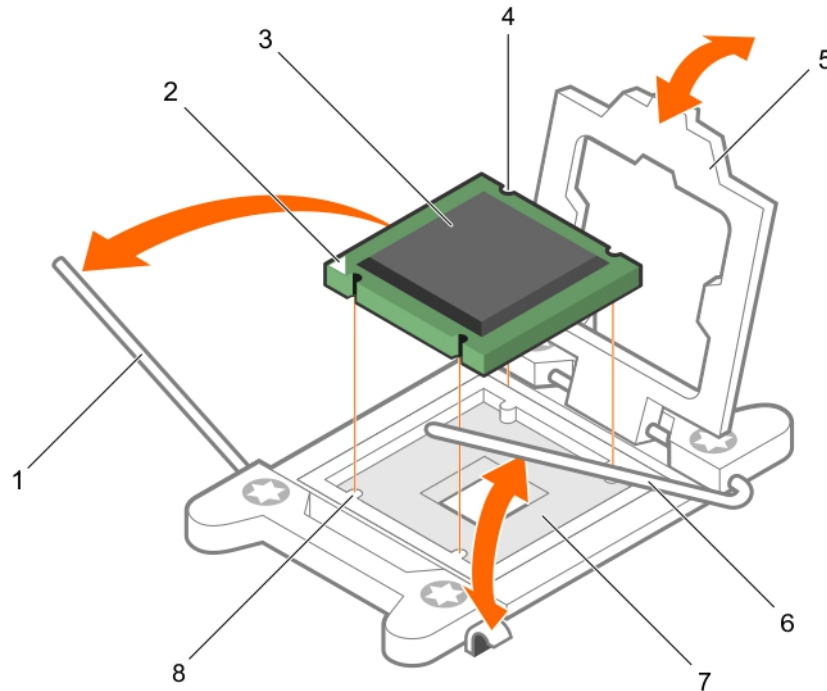

- a. socket-release lever 1
- b. pin-1 corner of the processor
- c. processor
- d. slot (4)
- e. processor shield
- f. socket-release lever 2
- g. processor socket
- h. tab (4)

After you finish

 **Note:** Ensure that you install the heat sink after you install the processor. The heat sink is necessary to maintain proper thermal conditions.

1. Install the heat sink.
2. If removed, reinstall the PCIe expansion card riser.

3. If disconnected, reconnect the cables to the expansion card(s).
4. Install the cooling shroud.
5. While booting, press F2 to enter System Setup and verify that the processor information matches the new system configuration.
6. Run the system diagnostics to verify that the new processor operates correctly.

Installing a heat sink

Before you begin

 **CAUTION** Many repairs may only be done by a certified service technician. You should only perform troubleshooting and simple repairs as authorized in your product documentation, or as directed by the online or telephone service and support team. Damage due to servicing that is not authorized by Dell is not covered by your warranty. Read and follow the safety instructions that are shipped with your product.

1. Follow the safety guidelines listed in the Safety instructions section.
2. Follow the procedure listed in the Before working inside your system section.
3. Keep the Phillips #2 screwdriver ready.
4. Install the processor.

 **Note:** If you are installing a single processor, it must be installed in socket CPU1.

Procedure

1. If you are using an existing heat sink, remove the thermal grease from the heat sink by using a clean lint-free cloth.
2. Use the thermal grease syringe included with your processor kit to apply the grease in a thin spiral on the top of the processor.

 **CAUTION** Applying too much thermal grease can result in excess grease coming in contact with and contaminating the processor socket.

 **Note:** The thermal grease syringe is intended for one-time use only. Dispose of the syringe after you use it.

Figure 68 Applying thermal grease on the top of the processor



- a. processor
- b. thermal grease
- c. thermal grease syringe

3. Place the heat sink onto the processor.
4. Tighten one of the four screws to secure the heat sink to the system board.
5. Tighten the screw diagonally opposite to the first screw you have tightened.

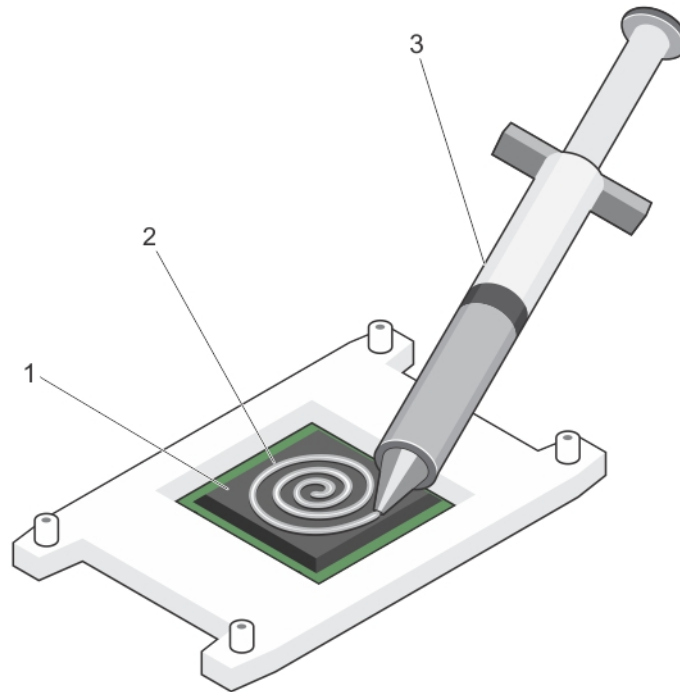
Note: Do not over-tighten the heat sink retention screws when installing the heat sink. To prevent over-tightening, tighten the retention screw until resistance is felt, and stop after the screw is seated. The screw tension should not be more than 6 in-lb (6.9 kg-cm).

6. Repeat the procedure for the remaining two screws.

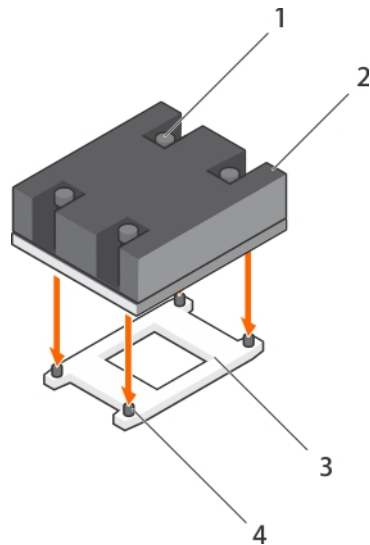
Figure 69 Installing the heat sink

- a. retention screw (4)
- b. heat sink
- c. processor socket
- d. retention screw slot (4)

After you finish

1. Follow the procedure listed in the After working inside your system section.
2. While booting, press F2 to enter System Setup and verify that the processor information matches the new system configuration.
3. Run the system diagnostics to verify that the new processor operates correctly.

Power supply units

Your system supports the following power supply units (PSUs):

- 450 W AC (non-redundant)
- 550 W AC (redundant)

When two identical PSUs are installed, the power supply configuration is redundant (1 + 1). In redundant mode, power is supplied to the system equally from both PSUs to maximize efficiency.

When only one PSU is installed, the power supply configuration is non-redundant (1 + 0). Power is supplied to the system only by the single PSU.

- Note:** If two PSUs are used, they must be of the same type and have the same maximum output power.
- Note:** For AC PSUs, use only PSU with the Extended Power Performance (EPP) label on the back. Mixing PSUs from previous generations of Dell PowerEdge servers can result in a PSU mismatch condition or failure to turn on.

Hot spare feature

Your system supports the hot spare feature that significantly reduces the power overhead associated with power supply unit (PSU) redundancy.

When the hot spare feature is enabled, one of the redundant PSUs is switched to the sleep state. The active PSU supports 100 percent of the load, thus operating at higher efficiency. The PSU in the sleep state monitors output voltage of the active PSU. If the output voltage of the active PSU drops, the PSU in the sleep state returns to an active output state.

If having both PSUs active is more efficient than having one PSU in the sleep state, the active PSU can also activate the sleeping PSU.

The default PSU settings are as follows:

- If the load on the active PSU is more than 50 percent, then the redundant PSU is switched to the active state.
- If the load on the active PSU falls below 20 percent, then the redundant PSU is switched to the sleep state.

You can configure the hot spare feature by using the iDRAC settings. For more information about iDRAC settings, see the *Integrated Dell Remote Access Controller User's Guide* available at Dell.com/idracmanuals.

Removing a redundant power supply unit

Before you begin

 **CAUTION** Many repairs may only be done by a certified service technician. You should only perform troubleshooting and simple repairs as authorized in your product documentation, or as directed by the online or telephone service and support team. Damage due to servicing that is not authorized by Dell is not covered by your warranty. Read and follow the safety instructions that are shipped with your product.

 **CAUTION** The system requires one power supply unit (PSU) for normal operation. On power-redundant systems, remove and replace only one PSU at a time in a system that is powered on.

1. Follow the safety guidelines listed in the Safety instructions section.
2. Disconnect the power cable from the power source.
3. Disconnect the power cable from the PSU and remove the straps that bundle and secure the system cables.
4. Unlatch and lift the optional cable management arm if it interferes with PSU removal. For information about the cable management arm, see the systems rack documentation at Dell.com/poweredgemanuals.

Procedure

1. Press the release latch and pull the PSU out of the chassis.

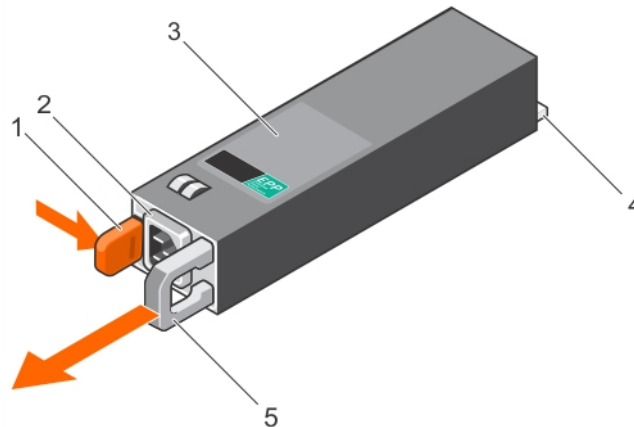
Figure 70 Removing a redundant PSU

- a. release latch
- b. PSU connector
- c. PSU
- d. power connector
- e. PSU handle

After you finish

Install the PSU.

Note: If you are removing the PSU permanently, install a PSU blank.

Installing a redundant power supply unit

Before you begin

CAUTION Many repairs may only be done by a certified service technician. You should only perform troubleshooting and simple repairs as authorized in your product documentation, or as directed by the online or telephone service and support team. Damage due to servicing that is not authorized by Dell is not covered by your warranty. Read and follow the safety instructions that are shipped with your product.

1. Follow the safety guidelines listed in the Safety instructions section.
2. Verify that both power supply units (PSUs) are of the same type and have the same maximum output power.

Note: The maximum output power (shown in Watt) is listed on the PSU label.

3. If installed, remove the PSU blank.

Procedure

1. Slide the new PSU into the chassis until the PSU is fully seated and the release latch snaps into place.

Figure 71 Installing a redundant PSU

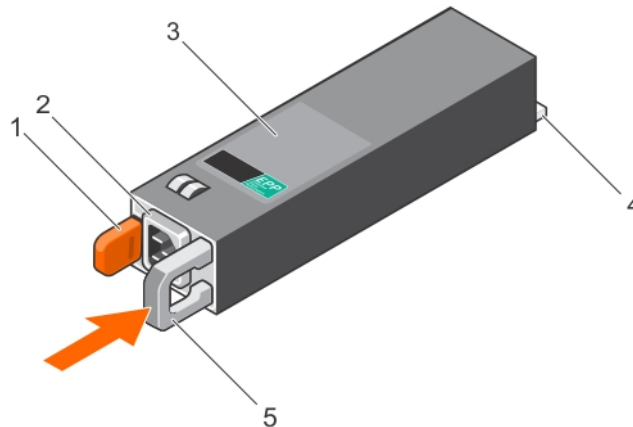

- a. release latch
- b. PSU cable connector
- c. PSU
- d. power connector
- e. PSU handle

After you finish

1. If you have unlatched the cable management arm, relatch it. For information about the cable management arm, see the rack documentation of the system.

2. Connect the power cable to the PSU and plug the cable into a power outlet.

CAUTION When connecting the power cable, secure the cable with the strap.

Note: When installing, hot-swapping, or hot-adding a new PSU in a system with two PSUs, allow several seconds for the system to recognize the PSU and determine its status. The PSU status indicator turns green to signify that the PSU is functioning properly.

Removing a cabled power supply unit

Before you begin

CAUTION Many repairs may only be done by a certified service technician. You should only perform troubleshooting and simple repairs as authorized in your product documentation, or as directed by the online or telephone service and support team. Damage due to servicing that is not authorized by Dell is not covered by your warranty. Read and follow the safety instructions that are shipped with your product.

1. Follow the safety guidelines listed in the Safety instructions section.

2. Follow the procedure listed in the Before working inside your system section.

3. Disconnect the power cable from the power source.

4. Disconnect the power cable from the power supply and remove the straps that bundle and secure the system cables.

Note: You may have to unlatch and lift the optional cable management arm if it interferes with the power supply unit (PSU) removal. For information about the cable management arm, see the system's rack documentation.

Procedure

1. Disconnect all the power cables from the PSU to the system board, hard drives, and optical drive.
2. Remove the screw securing the PSU to the chassis, slide and lift the power supply out of the chassis.

Figure 72 Removing a cabled PSU

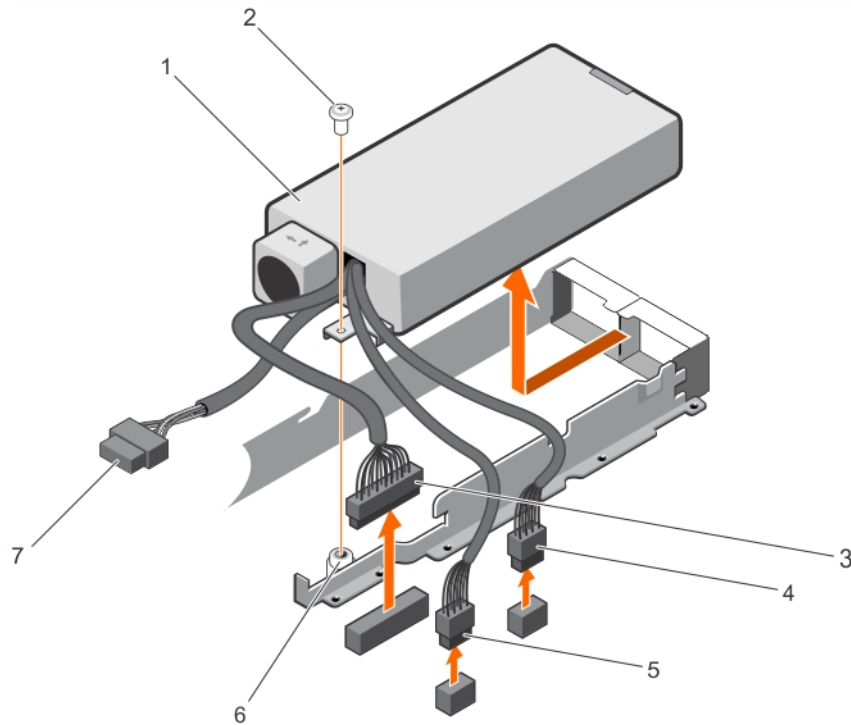

- a. PSU
- b. screw
- c. P1 cable connector
- d. P2 cable connector
- e. P3 cable connector
- f. standoff
- g. Backplane connector

After you finish

1. Install the cabled PSU.
2. Follow the procedure listed in After working inside your system section.

Installing a cabled power supply unit

Before you begin

CAUTION Many repairs may only be done by a certified service technician. You should only perform troubleshooting and simple repairs as authorized in your product documentation, or as directed by the online or telephone service and support team. Damage due to servicing that is

not authorized by Dell is not covered by your warranty. Read and follow the safety instructions that are shipped with your product.

1. Follow the safety guidelines listed in the Safety instructions section.
2. Follow the procedure listed in the Before working inside your system section.

Note: A hot-swappable non-redundant power supply unit (PSU) must be installed in Slot 1 of the PSU slot.

Procedure

1. Slide the PSU into the PSU slot.
2. Align the screw hole on the PSU with the standoff on the chassis.
3. Tighten the screw to secure the PSU to the chassis.
4. Connect all the power cables to the system board, hard drives, and optical drive.

Figure 73 Installing a cabled PSU

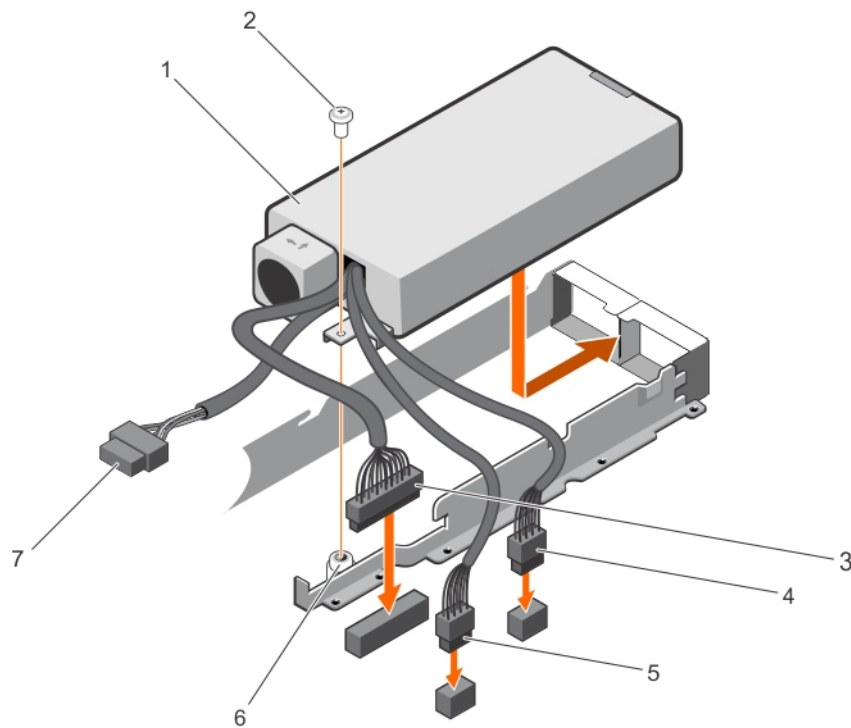

- a. PSU
- b. screw
- c. P1 cable connector
- d. P2 cable connector
- e. P3 cable connector
- f. standoff
- g. Backplane connector

After you finish

1. Follow the procedure listed in the After working inside your system section.

Removing the power supply unit blank

Install the power supply unit (PSU) blank only in the second PSU bay.

Before you begin

CAUTION Many repairs may only be done by a certified service technician. You should only perform troubleshooting and simple repairs as authorized in your product documentation, or as directed by the online or telephone service and support team. Damage due to servicing that is not authorized by Dell is not covered by your warranty. Read and follow the safety instructions that are shipped with your product.

Follow the safety guidelines listed in the Safety instructions section.

Procedure

1. If you are installing a second power supply unit (PSU), remove the PSU blank in the bay by pulling the blank outward.

CAUTION To ensure proper system cooling, the PSU blank must be installed in the second PSU bay in a non-redundant configuration. Remove the PSU blank only if you are installing a second PSU.

Figure 74 Removing the PSU blank

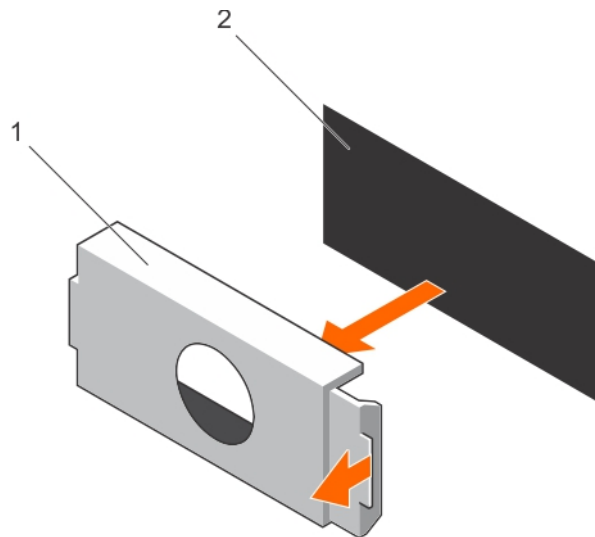

- a. PSU blank
- b. PSU bay

After you finish

Install the PSU or PSU blank.

Installing the power supply unit blank

Install the power supply unit (PSU) blank only in the second PSU bay.

Before you begin

CAUTION Many repairs may only be done by a certified service technician. You should only perform troubleshooting and simple repairs as authorized in your product documentation, or as directed by the online or telephone service and support team. Damage due to servicing that is

not authorized by Dell is not covered by your warranty. Read and follow the safety instructions that are shipped with your product.

1. Follow the safety guidelines listed in the Safety instructions section.

Procedure

1. Align the power supply unit blank with the power supply unit slot and push it into the power supply unit slot until it clicks into place.

Figure 75 Installing the PSU blank

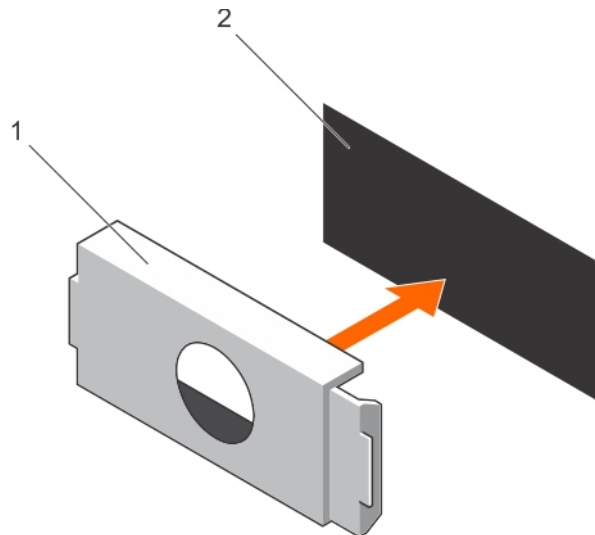

- a. PSU blank
- b. PSU bay

System battery

The system battery is used for low-level system functions like powering the real-time clock and storing the computer's BIOS settings.

Replacing the system battery

Before you begin

Note: There is a danger of a new battery exploding if it is incorrectly installed. Replace the battery only with the same or equivalent type recommended by the manufacturer. For more information, see the safety information that shipped with your system.

CAUTION Many repairs may only be done by a certified service technician. You should only perform troubleshooting and simple repairs as authorized in your product documentation, or as directed by the online or telephone service and support team. Damage due to servicing that is not authorized by Dell is not covered by your warranty. Read and follow the safety instructions that are shipped with your product.

1. Follow the safety guidelines listed in the Safety instructions section.
2. Follow the procedure listed in the Before working inside your system section.
3. Remove the cooling shroud.

4. If installed, remove the expansion card riser.

Procedure

1. Locate the battery socket. For more information, see the System board connectors section.

 **CAUTION** To avoid damage to the battery connector, you must firmly support the connector while installing or removing a battery.

2. Place your finger between the securing tabs at the negative side of the battery connector and lift the battery out of the socket.

Figure 76 Removing the system battery

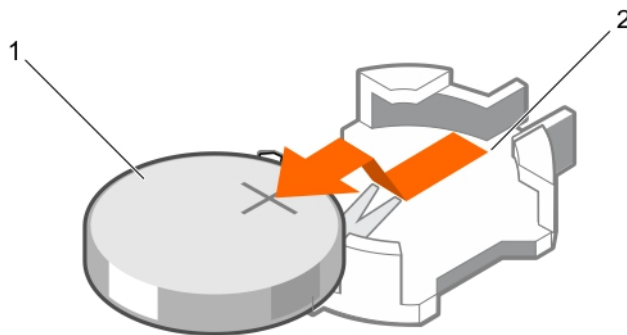

- a. system battery
- b. system battery slot

3. To install a new system battery, hold the battery with the "+" facing up and slide it under the securing tabs.
4. Press the battery into the connector until it snaps into place.

Figure 77 Installing the system battery

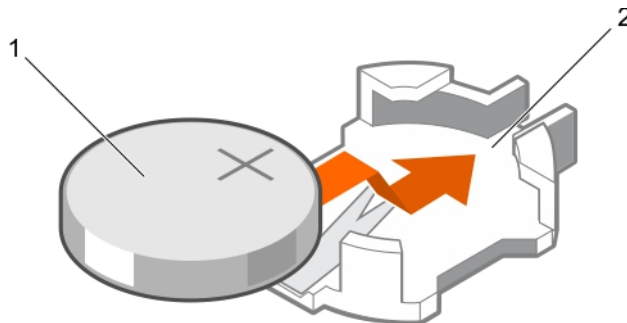

- a. system battery
- b. system battery slot

After you finish

1. Install the cooling shroud.
2. If removed, install the expansion card riser.
3. Follow the procedure listed in the After working inside your system section.
4. While booting, press F2 to enter System Setup and ensure the battery is operating properly.

5. Enter the correct time and date in the System Setup **Time** and **Date** fields.
6. Exit System Setup.

Hard-drive backplane

Depending on your system configuration:

PowerEdge R430 supports

Four 3.5 inch or 2.5 inch SAS/SATA backplane or

Eight 2.5 inch SAS/SATA backplane or

Ten 2.5 inch SAS/SATA backplane

Removing the hard drive backplane

Before you begin

 **CAUTION** Many repairs may only be done by a certified service technician. You should only perform troubleshooting and simple repairs as authorized in your product documentation, or as directed by the online or telephone service and support team. Damage due to servicing that is not authorized by Dell is not covered by your warranty. Read and follow the safety instructions that are shipped with your product.

 **CAUTION** To prevent damage to the drives and backplane, you must remove the hard drives from the system before removing the backplane.

 **CAUTION** You must note the number of each hard drive and temporarily label them before removal so that you can replace them in the same locations.

1. Follow the safety guidelines listed in the Safety instructions section.
2. Follow the procedure listed in the Before working inside your system section.
3. Remove all hard drives.

Procedure

1. Disconnect the SAS/SATA data, signal, and power cable(s) from the backplane.
2. Press the release tabs and lift the backplane upward and slide it toward the back of the chassis.

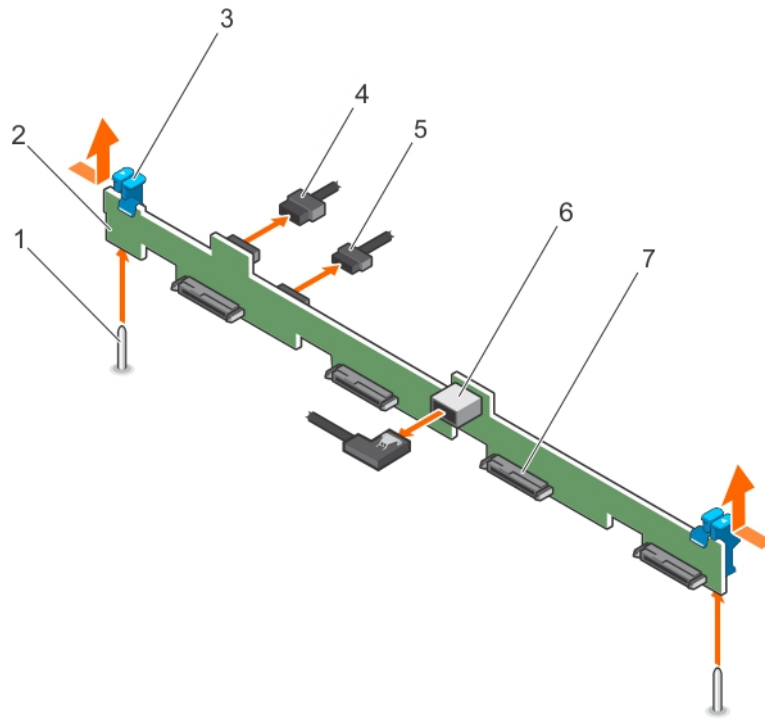
Figure 78 Removing the four 3.5 inch hard drive SAS/SATA backplane

- a. guide (2)
- b. hard drive/SSD backplane
- c. release tab (2)
- d. backplane power cable
- e. backplane signal cable
- f. SAS_A connector on the backplane
- g. hard drive/SSD connector (4)

Figure 79 Cabling diagram—Four 3.5 inch or 2.5 inch hard drive SAS/SATA backplane

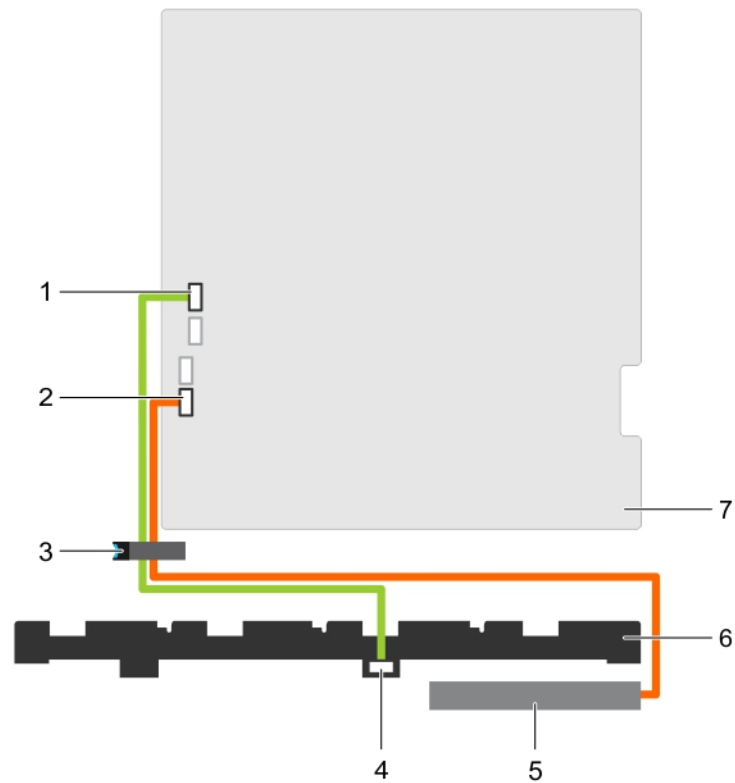

- a. SW_RAID_A connector on the system board
- b. SATA_CDROM connector on the system board
- c. cable routing latch
- d. SAS_A connector on the backplane
- e. Optical Disk Drive (ODD)
- f. hard drive backplane
- g. system board

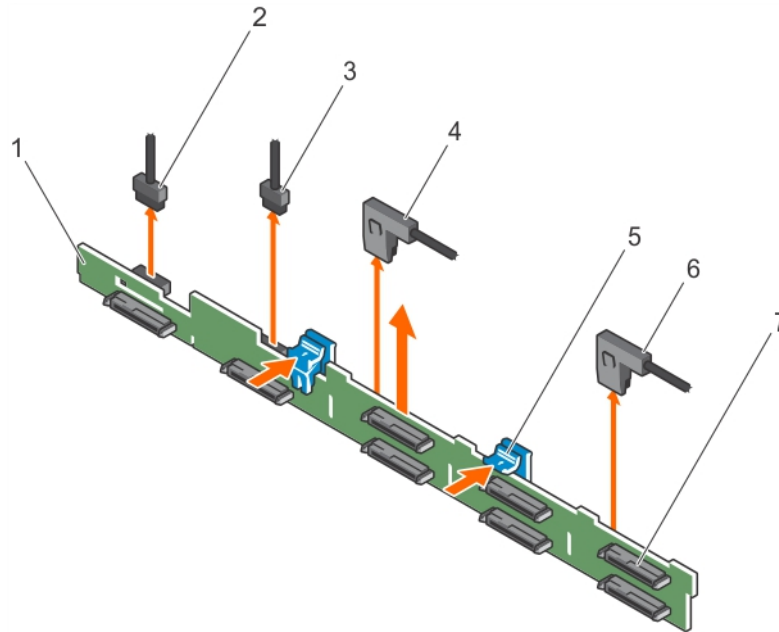
Figure 80 Removing the eight 2.5 inch SAS/SATA backplane

- a. hard drive/SSD backplane
- b. backplane power cable
- c. backplane signal cable
- d. SAS_A cable connector
- e. release tab (2)
- f. SAS_B cable connector
- g. hard drive/SSD connector (8)

Figure 81 Cabling diagram—Eight 2.5 inch SAS/SATA backplane

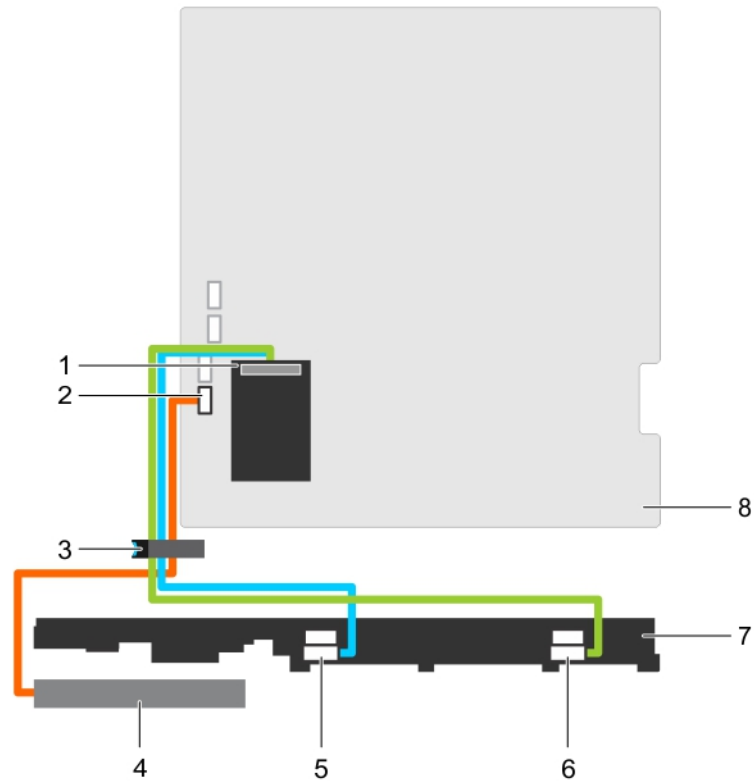

- a. integrated storage controller card
- b. SATA_CDROM connector on the system board
- c. cable routing latch
- d. Optical Disk Drive (ODD)
- e. SAS_A connector on the backplane
- f. SAS_ B connector on the backplane
- g. hard drive/SSD backplane
- h. system board

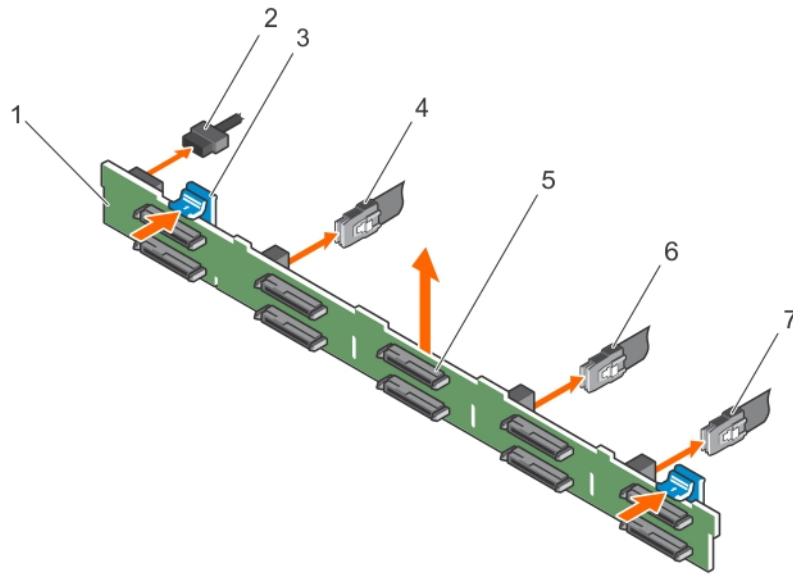
Figure 82 Removing the ten 2.5 inch SAS/SATA backplane

- a. hard drive/SSD backplane
- b. backplane power cable
- c. release tab (2)
- d. SAS_A connector on the backplane
- e. hard drive/SSD connector (10)
- f. SAS_B connector on the backplane
- g. SAS_C connector on the backplane

Figure 83 Cabling diagram—Ten 2.5 inch SAS/SATA backplane

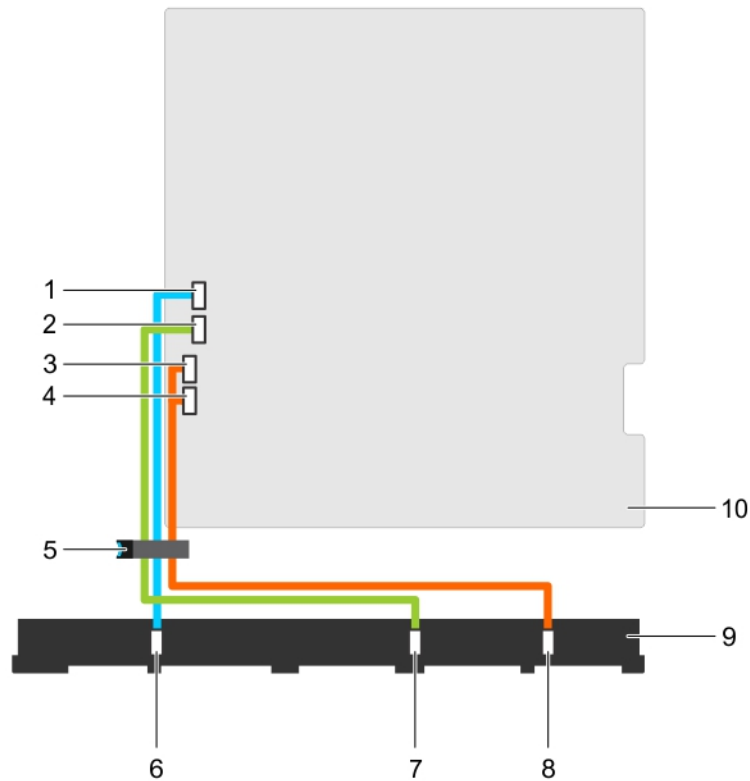

- a. SW_RAID_A connector on the system board
- b. SW_RAID_B connector on the system board
- c. SATA_hard drive8 connector on the system board
- d. SATA_hard drive9 connector on the system board
- e. cable routing latch
- f. SAS_A connector on the backplane
- g. SAS_B connector on the backplane
- h. SAS_C connector on the backplane
- i. hard drive/SSD backplane
- j. system board

After you finish

1. Install the hard drive backplane.
2. Install all the hard drives into their original slots.
3. Follow the procedure listed in the After working inside your system section.

Installing the hard drive backplane

Before you begin

CAUTION Many repairs may only be done by a certified service technician. You should only perform troubleshooting and simple repairs as authorized in your product documentation, or as directed by the online or telephone service and support team. Damage due to servicing that is not authorized by Dell is not covered by your warranty. Read and follow the safety instructions that are shipped with your product.

CAUTION To prevent damage to the control panel flex cable, do not bend the control panel flex cable after it is inserted into the connector.

1. Follow the safety guidelines listed in Safety instructions section.
2. Follow the procedure listed in the Before working inside your system section.

Procedure

1. Align the slots on the hard drive backplane with the hooks on the chassis.
2. Press down the hard drive backplane until the release tabs snap into place.
3. Connect the SAS/SATA/SSD data, signal, and power cables to the backplane.

Figure 84 Installing the four 3.5 inch hard drive SAS/SATA backplane

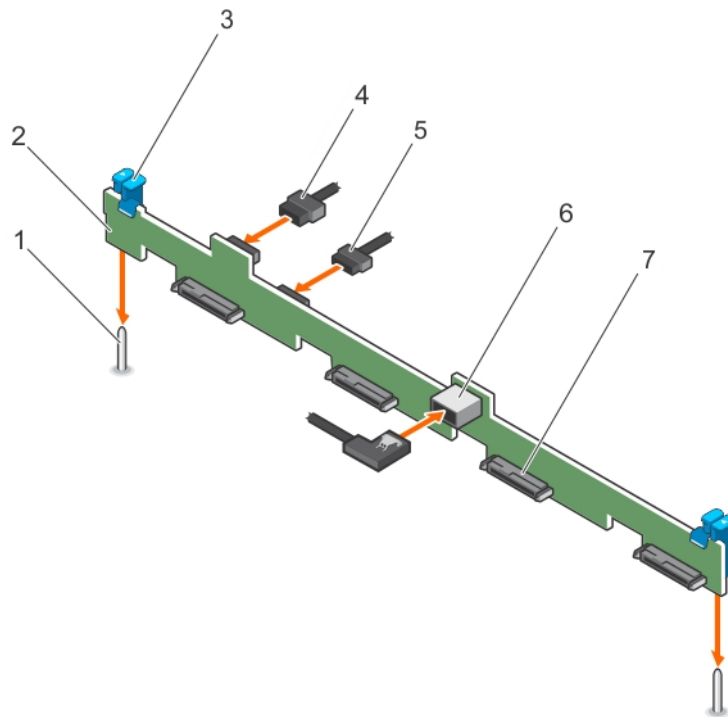

- a. guide (2)
- b. hard-drive/SSD backplane
- c. release tab (2)
- d. backplane power cable
- e. backplane signal cable
- f. SAS_A connector on the backplane

Figure 84 Installing the four 3.5 inch hard drive SAS/SATA backplane (continued)

g. hard-drive/SSD connector (4)

Figure 85 Installing the eight 2.5 inch SAS/SATA backplane

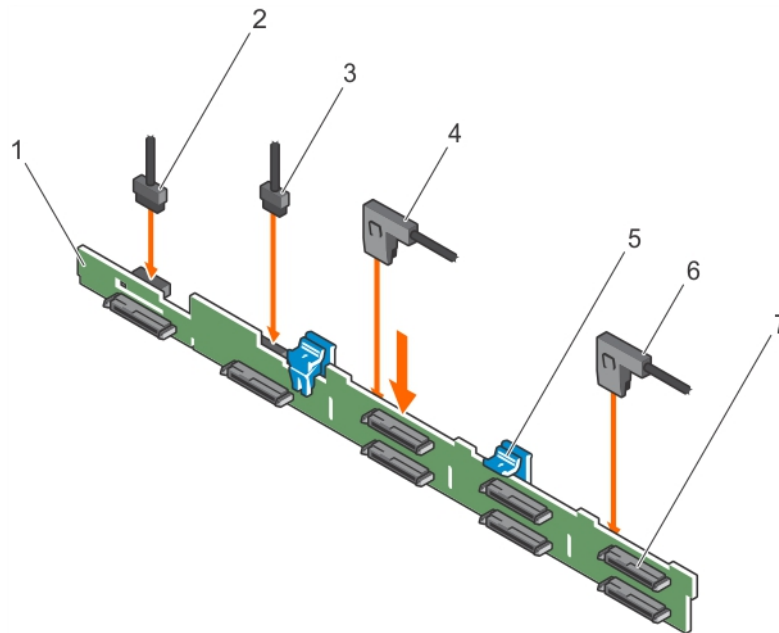

- a. hard-drive/SSD backplane
- b. backplane power cable
- c. backplane signal cable
- d. SAS_A cable connector
- e. release tab (2)
- f. SAS_B cable connector
- g. hard-drive/SSD connector (8)

Figure 86 Installing the ten 2.5 inch SAS/SATA backplane

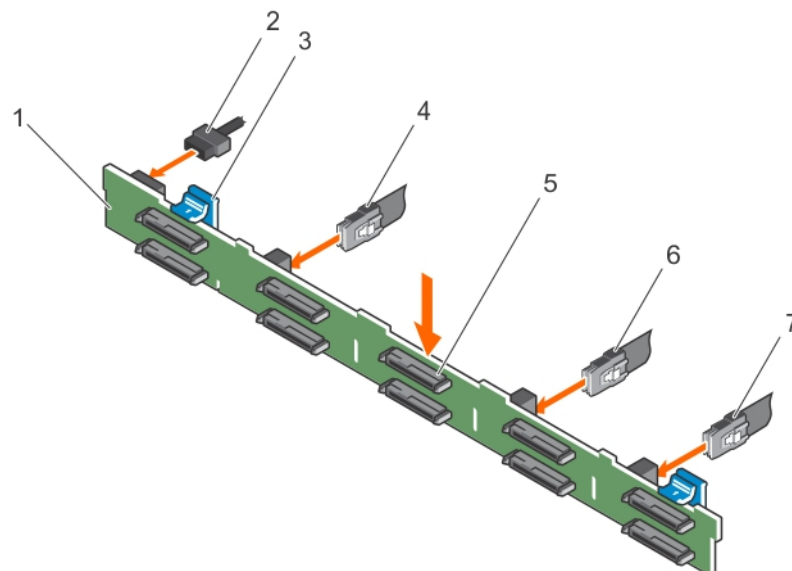

Figure 86 Installing the ten 2.5 inch SAS/SATA backplane (continued)

- a. hard drive/SSD backplane
- b. backplane power cable
- c. release tab (2)
- d. SAS_A connector on the backplane
- e. hard drive/SSD connector (10)
- f. SAS_B connector on the backplane
- g. SAS_C connector on the backplane

After you finish

1. Install the hard drives in their original locations.
2. Follow the procedure listed in the After working inside your system section.

Control panel

The control panel contains the power button, the diagnostic indicators, and the front USB ports.

Removing the control panel

Before you begin

 **CAUTION** Many repairs may only be done by a certified service technician. You should only perform troubleshooting and simple repairs as authorized in your product documentation, or as directed by the online or telephone service and support team. Damage due to servicing that is not authorized by Dell is not covered by your warranty. Read and follow the safety instructions that are shipped with your product.

1. Follow the safety guidelines listed in the Safety instructions section.
2. Follow the procedure listed in the Before working inside your system section.
3. Keep the Phillips #2 screwdriver ready.

Procedure

1. Using a Phillips #2 screwdriver, remove the screw(s) securing the control panel to the chassis.

 **CAUTION** Do not use excessive force when removing the control panel as it can damage the connectors.

2. Release the locking tabs of the control panel by angling the control panel up and away from the system.

For an eight 2.5 inch hot-swappable hard-drive chassis, remove the screw (located at the bottom of the chassis) that secures the control panel to the chassis.

For a ten 2.5 inch hot-swappable hard-drive chassis, press the control panel latch and slide the control panel out of the chassis.

3. Remove all the cables connecting the control panel to the chassis.

Figure 87 Removing the control panel—four 3.5-inch hard drives chassis

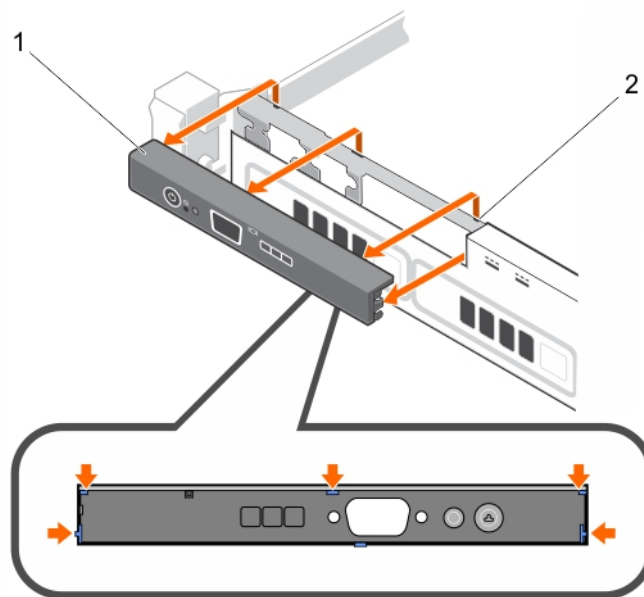

- a. control panel
- b. notches (5)

Figure 88 Removing the control panel—eight 2.5-inch hard drives/SSDs chassis

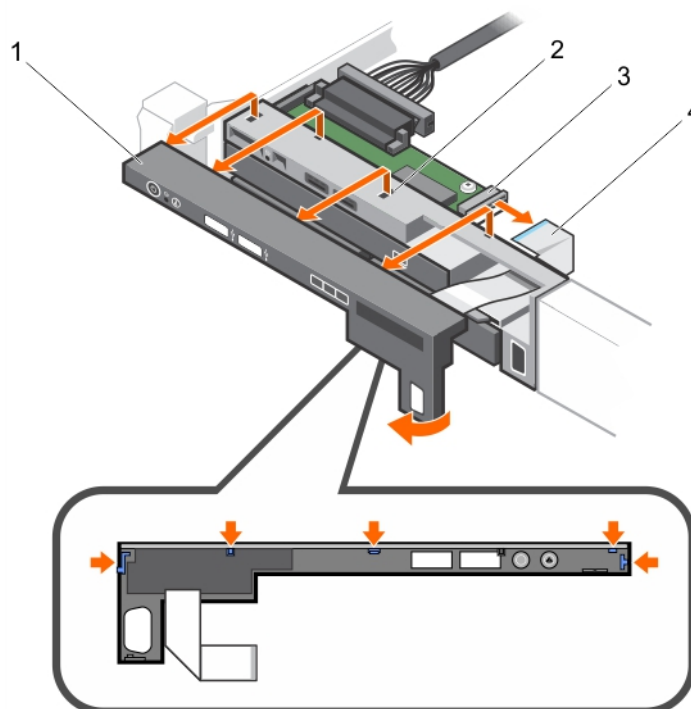

- a. control panel
- b. notches (5)
- c. control panel module
- d. LCD connector cable

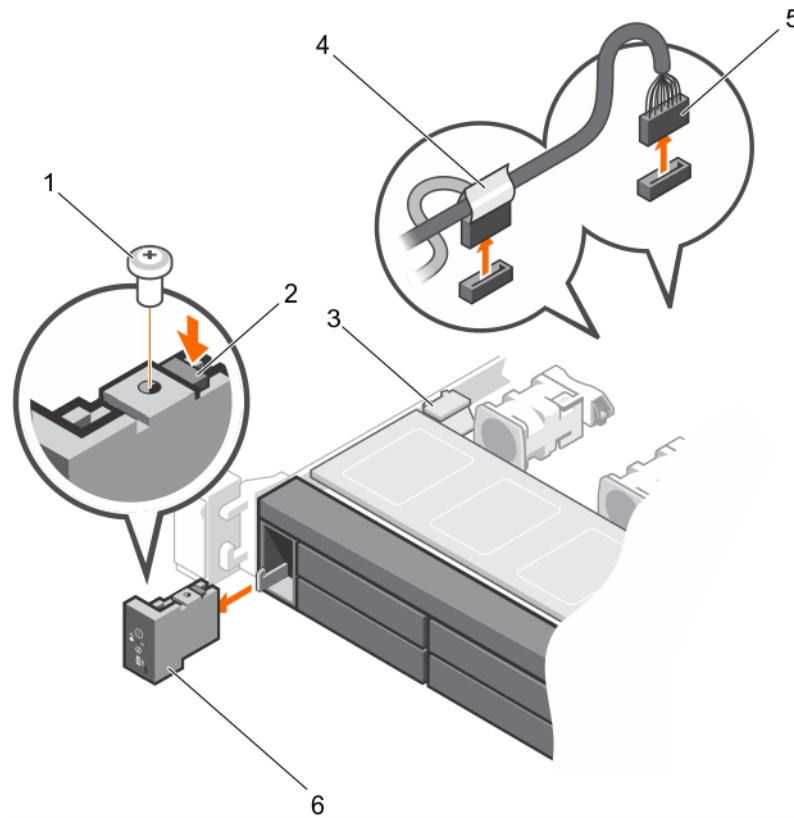
Figure 89 Removing the control panel—ten 2.5-inch hard drives/SSDs chassis

- a. screw
- b. control panel release latch
- c. cable securing clip
- d. control panel cable connecting to the system board
- e. J_FP_USB connector cable
- f. control panel

After you finish

1. Replace the control panel.
2. Follow the procedure listed in the After working inside your system section.

Installing the control panel**Before you begin**

CAUTION Many repairs may only be done by a certified service technician. You should only perform troubleshooting and simple repairs as authorized in your product documentation, or as directed by the online or telephone service and support team. Damage due to servicing that is not authorized by Dell is not covered by your warranty. Read and follow the safety instructions that are shipped with your product.

1. Follow the safety guidelines listed in the Safety instructions section.
2. Follow the procedure listed in the Before working inside your system section.
3. Keep the Phillips #2 screwdriver ready.

Procedure

1. Align the locking tabs on the control panel with the notches on the chassis and angle the control panel until it snaps into place.

When properly seated, the control panel will be flush with the front panel.

Note: For an eight 2.5 inch hard drive chassis, tighten the screw to secure the control panel to the bottom of the chassis.

Note: For a ten 2.5 inch hard-drive chassis, slide the control panel into the chassis and secure the module with the screw.

Figure 90 Installing the control panel—four 3.5 inch hard-drives chassis

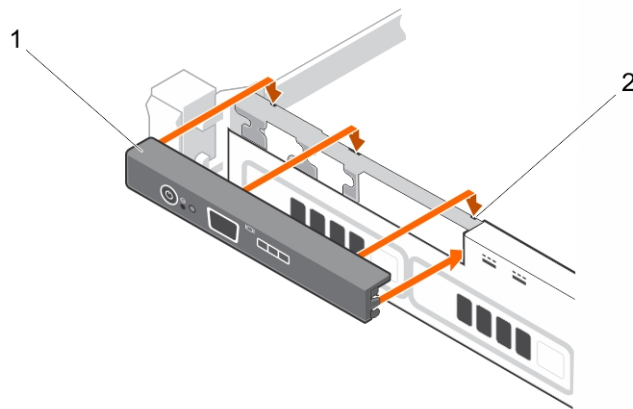

- a. control panel
- b. notches (6)

Figure 91 Installing the control panel—eight 2.5 inch hard-drives/SSDs chassis

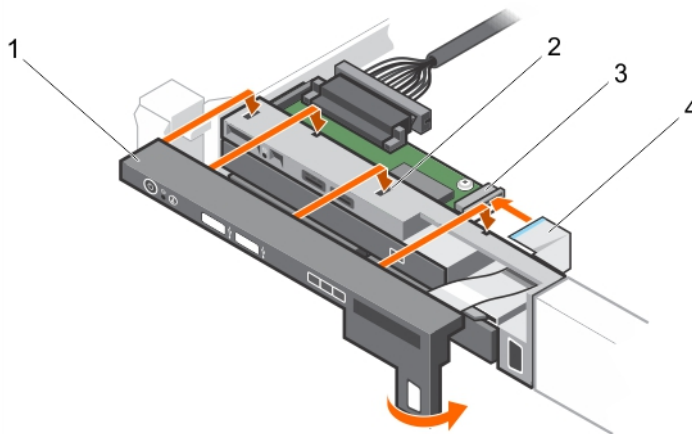

- a. control panel
- b. notches (4)
- c. control panel module
- d. LCD connector cable

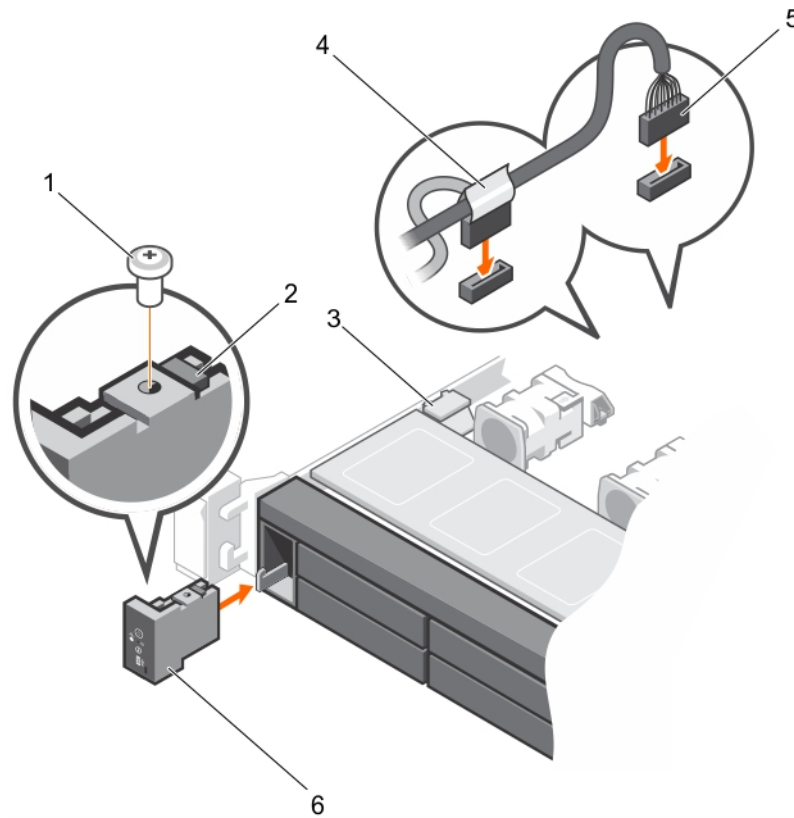
Figure 92 Installing the control panel—ten 2.5 inch hard-drives/SSDs chassis

- a. screw
- b. control panel release latch
- c. cable securing clip
- d. control panel cable connecting to the system board
- e. J_FP_USB connector cable
- f. control panel

After you finish

Follow the procedure listed in the After working inside your system section.

Removing the control panel module**Before you begin**

CAUTION Many repairs may only be done by a certified service technician. You should only perform troubleshooting and simple repairs as authorized in your product documentation, or as directed by the online or telephone service and support team. Damage due to servicing that is not authorized by Dell is not covered by your warranty. Read and follow the safety instructions that are shipped with your product.

1. Follow the safety guidelines listed in the Safety instructions section.
2. Follow the procedure listed in the Before working inside your system section.

CAUTION Do not use excessive force when removing the control panel as it can damage the connectors.

Procedure

1. Remove the screw(s) securing the control panel module to the chassis.
2. For a 3.5 inch cabled hard-drive chassis:
 - a. Remove the screw(s) securing the LED panel to the chassis.
 - b. Remove the LED panel.
3. Remove all the cables connecting the control panel module to the chassis.

Figure 93 Removing the control panel module—four cabled hard-drive chassis

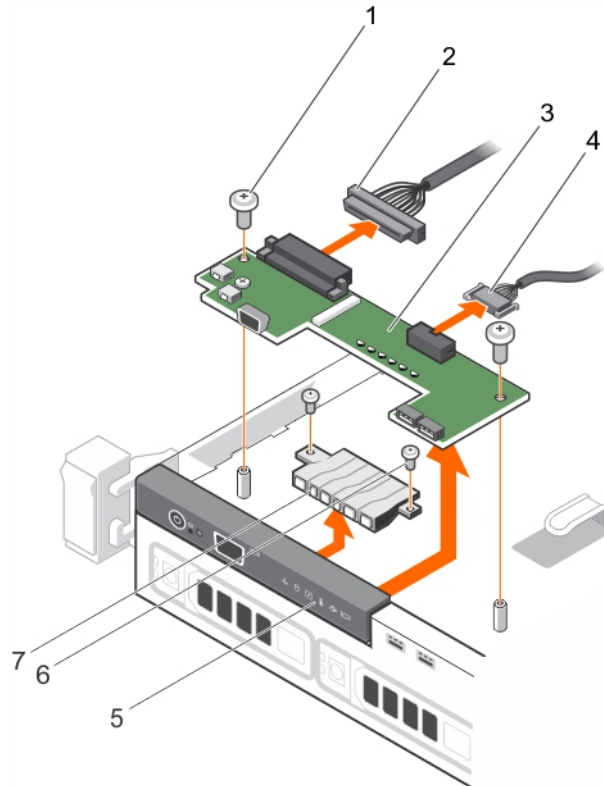

- a. screw (2)
- b. control panel module connector cable
- c. control panel module
- d. USB connector cable
- e. control panel
- f. LED-panel screw (2)
- g. LED panel

Figure 94 Removing the control panel module—four hard-drive chassis

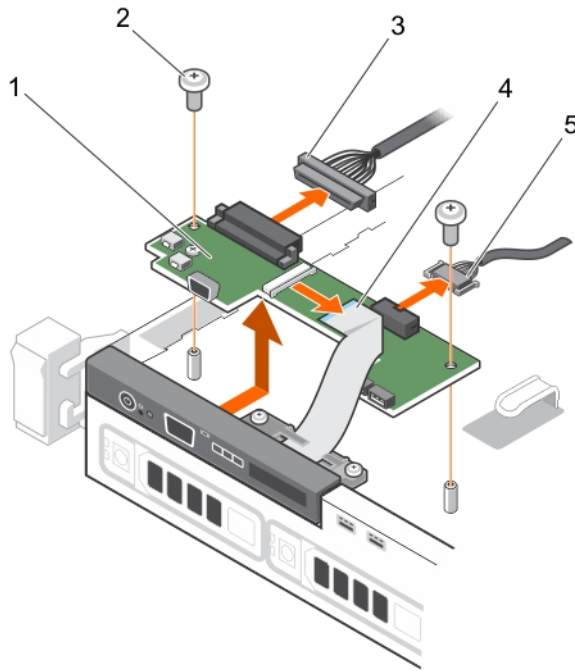

- a. control panel module
- b. control panel module screws (2)
- c. control panel module connector cable
- d. display module cable
- e. USB connector cable

Figure 95 Removing the control panel module—eight hard-drive chassis

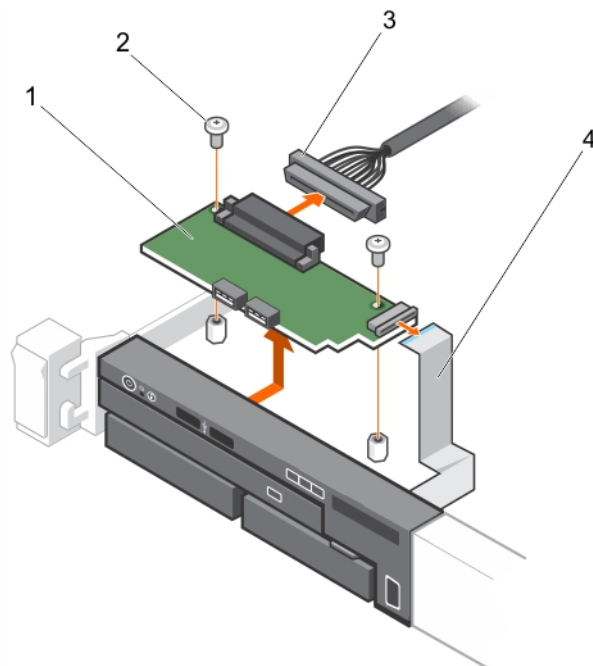

- a. control panel module

Figure 95 Removing the control panel module—eight hard-drive chassis (continued)

- b. screw (2)
- c. control panel module connector cable
- d. display module cable

After you finish

Follow the procedure listed in the After working inside your system section.

Installing the control panel module

Before you begin

 **CAUTION** Many repairs may only be done by a certified service technician. You should only perform troubleshooting and simple repairs as authorized in your product documentation, or as directed by the online or telephone service and support team. Damage due to servicing that is not authorized by Dell is not covered by your warranty. Read and follow the safety instructions that are shipped with your product.

1. Follow the safety guidelines listed in the Safety instructions section.
2. Follow the procedure listed in the Before working inside your system section.

Procedure

1. For a 3.5 inch cabled hard drive system:
 - a. Insert the LED panel into the slot in the chassis.
 - b. Secure the LED panel with the screws.
2. Insert the control panel module into the slot in the chassis and align the two screw holes on the control panel module with the corresponding holes on the chassis.
3. Secure the control panel module with the screws.
4. Connect all the applicable cables to the control panel module.

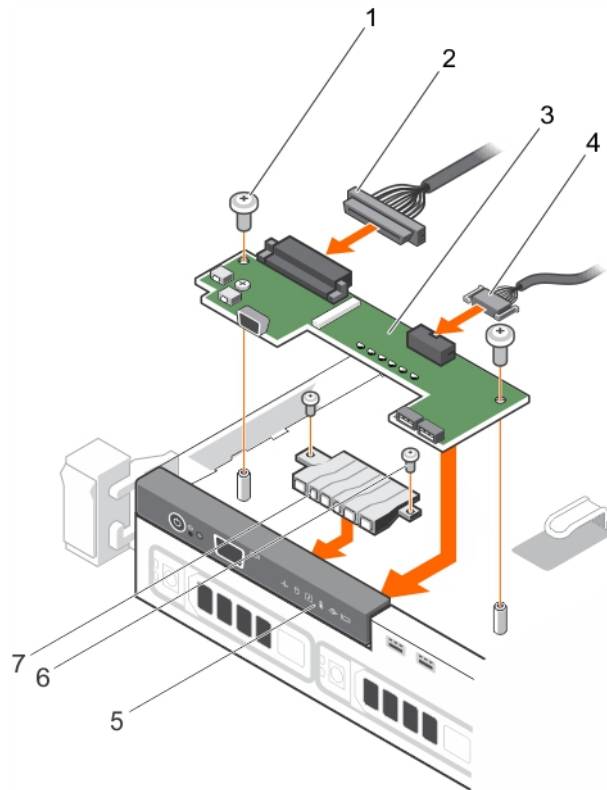
Figure 96 Installing the control panel module—four cabled hard-drive chassis

- a. screw (2)
- b. control panel module connector cable
- c. control panel module
- d. USB connector cable
- e. control panel
- f. LED-panel screw (2)
- g. LED panel

Figure 97 Installing the control panel module—four hard-drive chassis

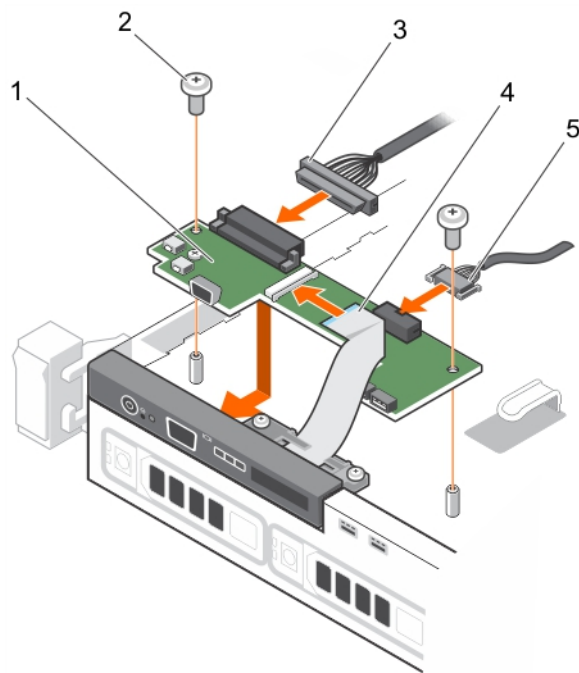

- a. control panel module
- b. control panel module screws (2)
- c. control panel module connector cable
- d. display module cable
- e. USB connector cable

Figure 98 Installing the control panel module—eight hard-drive chassis

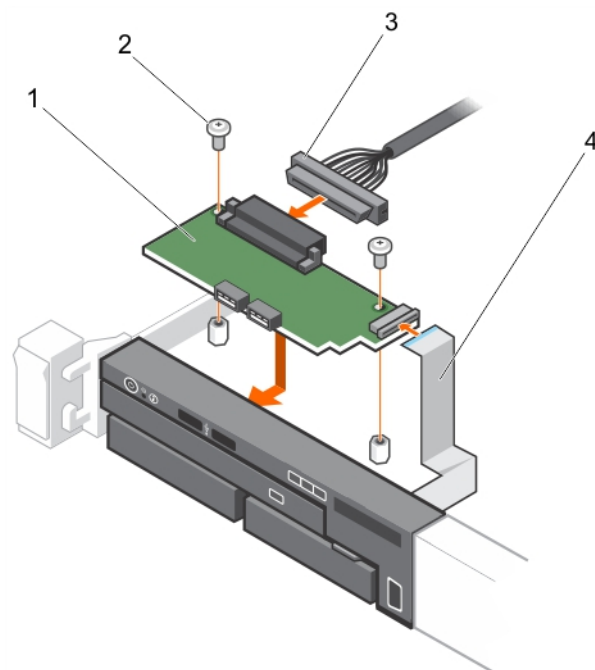

- a. control panel module

Figure 98 Installing the control panel module—eight hard-drive chassis (continued)

- b. screw (2)
- c. control panel module connector cable
- d. display module cable

After you finish

Follow the procedure listed in the After working inside your system section.

Power interposer board

The power interposer board (PIB) is a board that connects the redundant power supply units (PSUs) to the system board. The PIB is only supported in systems with redundant PSUs.

Removing the power interposer board

Before you begin

 **CAUTION** Many repairs may only be done by a certified service technician. You should only perform troubleshooting and simple repairs as authorized in your product documentation, or as directed by the online or telephone service and support team. Damage due to servicing that is not authorized by Dell is not covered by your warranty. Read and follow the safety instructions that are shipped with your product.

 **Note:** The power interposer board (PIB) is present only in systems that support redundant power supply units (PSUs).

1. Follow the safety guidelines listed in the Safety instructions section.
2. Follow the procedure listed in the Before working inside your system section.
3. Remove the PSUs from the system.
4. Keep the Phillips #2 screwdriver ready.

Procedure

1. Disconnect the power distribution cables from the system board.
2. Disconnect the fan cable.
3. Remove the two screws securing the PIB to the chassis and lift the board out of the chassis.

Figure 99 Removing the power interposer board

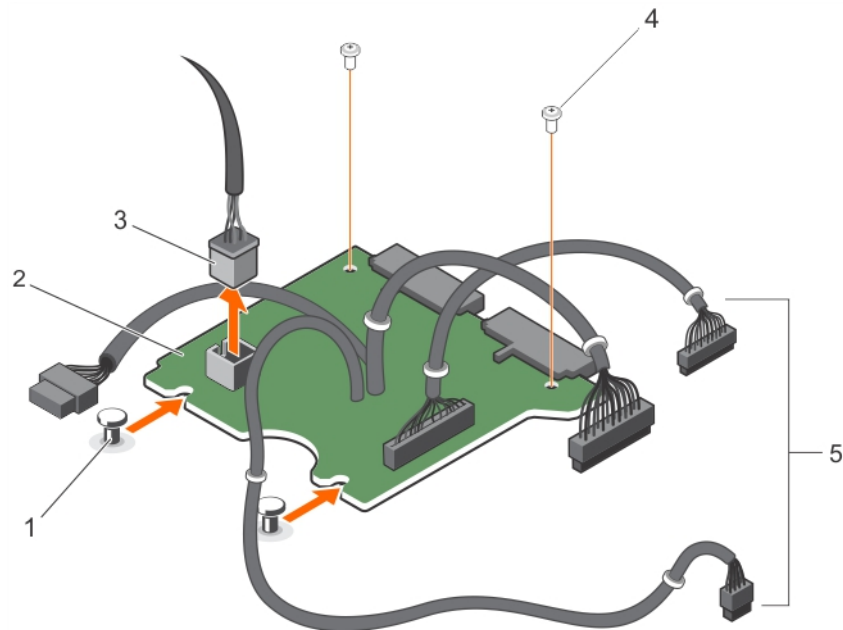

- a. standoffs (2)
- b. power interposer board
- c. fan cable connector
- d. screw (2)
- e. PSU cables to the system board (3)

After you finish

Follow the procedure listed in After working inside your system section.

Installing the power interposer board

Before you begin

CAUTION Many repairs may only be done by a certified service technician. You should only perform troubleshooting and simple repairs as authorized in your product documentation, or as directed by the online or telephone service and support team. Damage due to servicing that is not authorized by Dell is not covered by your warranty. Read and follow the safety instructions that are shipped with your product.

1. Follow the safety guidelines listed in the Safety instructions section.
2. Follow the procedure listed in Before working inside your system section.
3. Keep the Phillips #2 screwdriver ready.
4. Remove the redundant power supply unit.

Procedure

1. Align the power interposer board (PIB) with the standoffs on the chassis.
2. Install the two screws that secure the PIB to the chassis.
3. Connect the power distribution cables to the system board and fan cable connector to PIB.

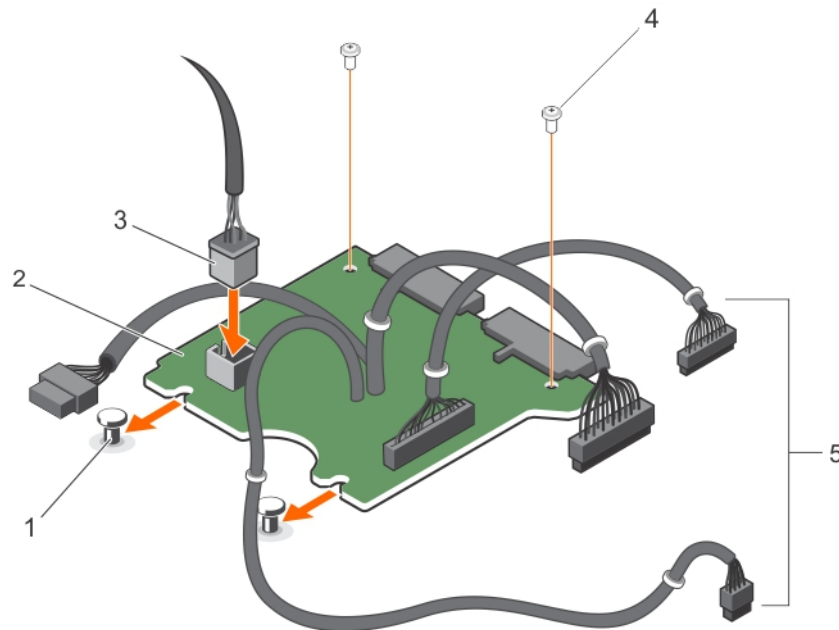
Figure 100 Installing the power interposer board

- a. standoffs (2)
- b. power interposer board
- c. fan cable connector
- d. screw (2)
- e. PSU cables to the system board (3)

After you finish

1. Install the power supply units.
2. Follow the procedure listed in After working inside your system section.

System board

A system board (also known as the motherboard) is the main printed circuit board found in systems. The system board allows communication between many of the crucial electronic components of the system, such as the central processing unit (CPU) and memory, and also provides connectors for other peripherals. Unlike a backplane, a system board contains significant number of sub-systems such as the processor expansion cards, and other components.

Removing the system board

Before you begin

- ⚠ **CAUTION** Many repairs may only be done by a certified service technician. You should only perform troubleshooting and simple repairs as authorized in your product documentation, or as directed by the online or telephone service and support team. Damage due to servicing that is not authorized by Dell is not covered by your warranty. Read and follow the safety instructions that are shipped with your product.
- ⚠ **CAUTION** If you are using the Trusted Program Module (TPM) with an encryption key, you may be prompted to create a recovery key during program or System Setup. Be sure to create

and safely store this recovery key. If you replace this system board, you must supply the recovery key when you restart your system or program before you can access the encrypted data on your hard drives.

 **CAUTION** Do not attempt to remove the TPM plug-in module from the system board. Once the TPM plug-in module is installed, it is cryptographically bound to that specific system board. Any attempt to remove an installed TPM plug-in module breaks the cryptographic binding, and it cannot be re-installed or installed on another system board.

1. Follow the safety guidelines listed in the Safety instructions section.
2. Follow the procedure listed in the Before working inside your system section.
3. Keep the Phillips #2 screwdriver ready.
4. Remove the following:
 - a. cooling shroud
 - b. memory modules
 - c. cooling fan cables
 - d. expansion card riser
 - e. integrated storage controller card
 - f. heat sink and processor
 - g. internal dual SD module

Procedure

1. Disconnect all other cables from the system board.

 **CAUTION** Take care not to damage the system identification button while removing the system board from the chassis.

2. Remove the nine screws on the system board and slide the system board toward the front of the system.
3. Hold the system board t-handle and lift the system board out of the chassis.

 **Note:** To prevent damage to the system board, ensure that you hold the system board by its edges only.

 **CAUTION** Do not lift the system board by holding a memory module, processor, or other components.

Figure 101 Removing the system board

- a. screw (9)
- b. system board
- c. system board t-handle

Installing the system board

Before you begin

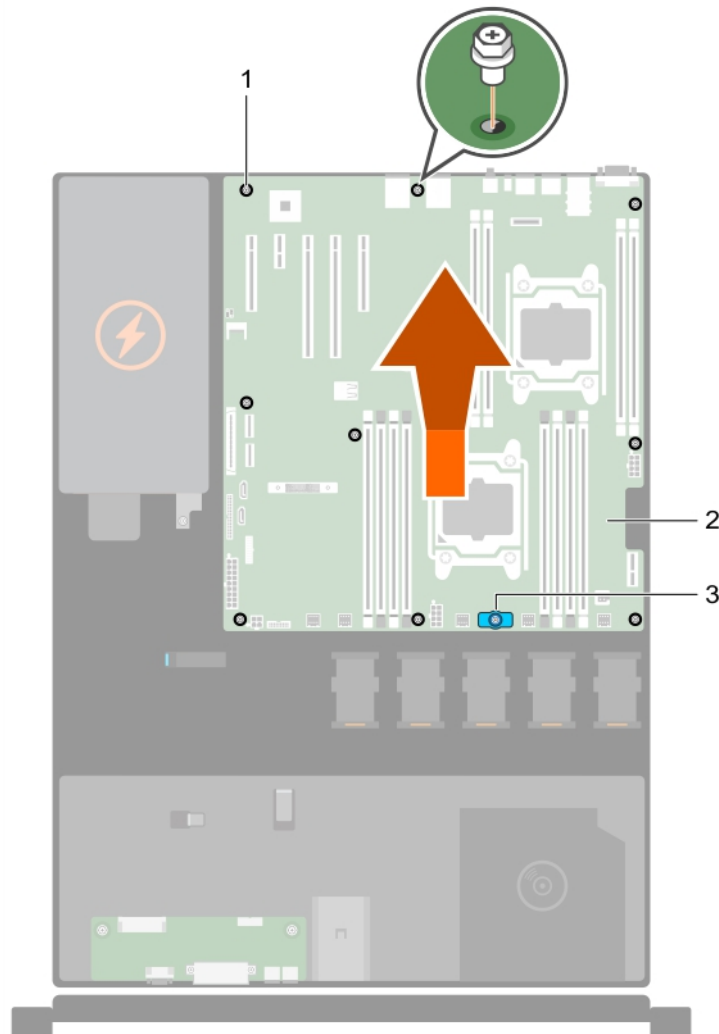
- ⚠ **CAUTION** Many repairs may only be done by a certified service technician. You should only perform troubleshooting and simple repairs as authorized in your product documentation, or as directed by the online or telephone service and support team. Damage due to servicing that is not authorized by Dell is not covered by your warranty. Read and follow the safety instructions that are shipped with your product.
- ⚠ **CAUTION** Do not lift the system board by holding a memory module, processor, or other components.
- ⚠ **CAUTION** Take care not to damage the system identification button while placing the system board into the chassis.

1. Follow the safety guidelines listed in the Safety instructions section.
2. Follow the procedure listed in the Before working inside your system section.
3. Keep the Phillips #2 screwdriver ready.
4. Unpack the new system board assembly.

Procedure

1. Hold the system board by its edges and the system board t-handle, and angle it toward the back of the chassis.
2. Lower the system board into the chassis till the connectors at the back of the system board align with the slots on the rear wall of the chassis, and the screw holes on the system board align with the standoffs on the chassis.
3. Tighten the nine screws that secure the system board to the chassis.

Figure 102 Installing the system board

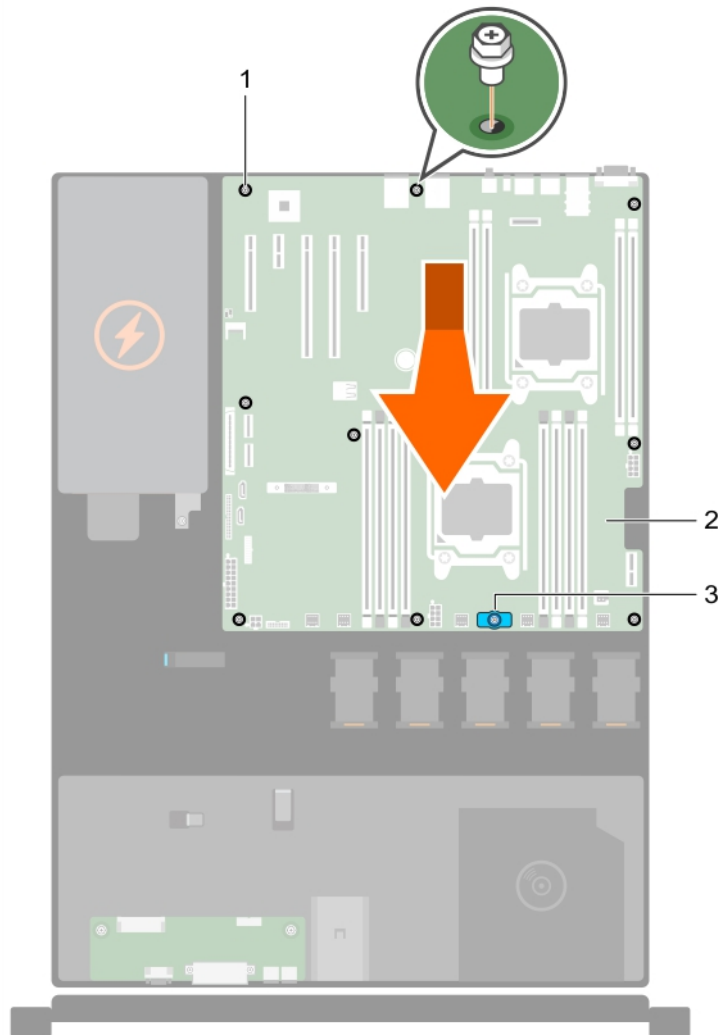

- a. screw (9)
- b. system board
- c. system board t-handle

After you finish

1. Install the Trusted Platform Module (TPM). See the Installing the Trusted Platform Module section.
2. Replace the following:
 - a. internal dual SD module
 - b. heat sink/heat sink blank and processor/processor blank
 - c. expansion card riser
 - d. expansion cards
 - e. integrated storage controller card
 - f. memory modules
 - g. cooling shroud
3. Reconnect all cables to the system board.

 **Note:** Ensure that the cables inside the system are routed through the cable routing latch.
4. Follow the procedure listed in the After working inside your system section.
5. Import your new or existing iDRAC Enterprise license. For more information, see the *Integrated Dell Remote Access Controller User's Guide* at Dell.com/idracmanuals.
6. Ensure that you:
 - a. Use the Easy Restore feature to restore the service tag. See [Restoring the Service Tag by using the Easy Restore feature](#) on page 187.
 - b. If the Service Tag is not backed up in the backup flash device, enter the system service tag manually. See [Entering the system Service Tag by using System Setup](#) on page 188.
 - c. Update the BIOS and iDRAC versions.
 - d. Re-enable the Trusted Platform Module (TPM). See [Initializing the TPM for BitLocker users](#) on page 189 or [Initializing the TPM for TXT users](#) on page 189.

Restoring the Service Tag by using the Easy Restore feature

The Easy Restore feature enables you to restore your system's Service Tag, license, UEFI configuration, and the system configuration data after replacing the system board. All data is automatically backed up in a backup flash device. If BIOS detects a new system board and the Service Tag in the backup flash device, BIOS prompts the user to restore the backup information.

Procedure

1. Turn on the system.

If BIOS detects a new system board, and if the Service Tag is present in the backup flash device, BIOS displays the Service Tag, the status of the license, and the **UEFI Diagnostics** version.
2. Perform one of the following steps:

After the restore process is complete, BIOS prompts to restore the system configuration data.
3. Perform one of the following steps:
 - Press **Y** to restore the system configuration data.
 - Press **N** to use the default configuration settings.

After the restore process is complete, the system restarts.

Entering the system Service Tag by using System Setup

If Easy Restore fails to restore the Service Tag, use System Setup to enter the Service Tag.

Procedure

1. Turn on the system.
2. Press F2 to enter System Setup.
3. Click **Service Tag Settings**.
4. Enter the Service Tag.

 **Note:** You can enter the Service Tag only when the **Service Tag** field is empty. Ensure that you enter the correct Service Tag. After the Service Tag is entered, it cannot be updated or changed.

5. Click **Ok**.
6. Import your new or existing iDRAC Enterprise license.

For more information, see the *Integrated Dell Remote Access Controller User's Guide* at Dell.com/idracmanuals.

Trusted Platform Module

Trusted Platform Module (TPM) is a dedicated microprocessor designed to secure hardware by integrating cryptographic keys into devices. A software can use a Trusted Platform Module to authenticate hardware devices. As each TPM chip has a unique and secret RSA key burned in as it is produced, it can perform the platform authentication.

 **CAUTION** Do not attempt to remove the Trusted Platform Module (TPM) from the system board. After the TPM is installed, it is cryptographically bound to that specific system board. Any attempt to remove an installed TPM breaks the cryptographic binding, and it cannot be re-installed or installed on another system board.

 **Note:** This is a Field Replaceable Unit (FRU). Removal and installation procedures must be performed only by Dell certified service technicians.

Installing the Trusted Platform Module

Before you begin

 **CAUTION** Many repairs may only be done by a certified service technician. You should only perform troubleshooting and simple repairs as authorized in your product documentation, or as directed by the online or telephone service and support team. Damage due to servicing that is not authorized by Dell is not covered by your warranty. Read and follow the safety instructions that are shipped with your product.

1. Follow the safety guidelines listed in the Safety instructions section.
2. Follow the procedure listed in the Before working inside your system section.

Procedure

1. Locate the TPM connector on the system board.

 **Note:** To locate the TPM connector on the system board, see the System board connectors section.

2. Align the edge connectors on the TPM with the slot on the TPM connector.
3. Insert the TPM into the TPM connector such that the plastic rivet aligns with the slot on the system board.
4. Press the plastic rivet until the rivet snaps into place.

Figure 103 Installing the TPM

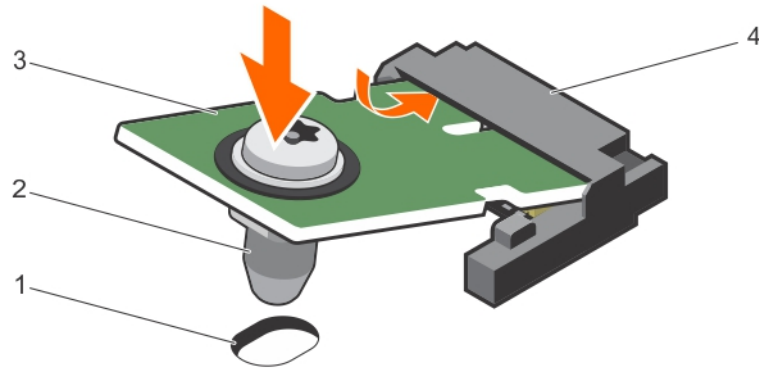

- a. rivet slot on the system board
- b. plastic rivet
- c. TPM
- d. TPM connector

After you finish

1. Install the system board.
2. Follow the procedure listed in the After working inside your system section.

Initializing the TPM for BitLocker users

Procedure

1. Initialize the TPM.

For more information about initializing the TPM, see <http://technet.microsoft.com/en-us/library/cc753140.aspx>.

The TPM Status changes to **Enabled, Activated**.

Initializing the TPM for TXT users

Procedure

1. While booting your system, press F2 to enter System Setup.
2. On the **System Setup Main Menu** screen, click **System BIOS** → **System Security Settings**.
3. From the **TPM Security** option, select **On with Pre-boot Measurements**.
4. From the **TPM Command** option, select **Activate**.
5. Save the settings.
6. Restart your system.
7. Enter **System Setup** again.

8. On the **System Setup Main Menu** screen, click **System BIOS → System Security Settings**.
9. From the **Intel TXT** option, select **On**.

CHAPTER 7

Using system diagnostics

If you experience a problem with your system, run the system diagnostics before contacting Dell for technical assistance. The purpose of running system diagnostics is to test your system hardware without requiring additional equipment or risking data loss. If you are unable to fix the problem yourself, service and support personnel can use the diagnostics results to help you solve the problem.

- [Dell Embedded System Diagnostics](#)..... 192

Dell Embedded System Diagnostics

 **Note:** The Dell Embedded System Diagnostics is also known as Enhanced Pre-boot System Assessment (ePSA) diagnostics.

The Embedded System Diagnostics provides a set of options for particular device groups or devices allowing you to:

- Run tests automatically or in an interactive mode
- Repeat tests
- Display or save test results
- Run thorough tests to introduce additional test options to provide extra information about the failed device(s)
- View status messages that inform you if tests are completed successfully
- View error messages that inform you of problems encountered during testing

When to use the Embedded System Diagnostics

Run the Embedded System Diagnostics (ePSA) if your system does not boot.

Running the Embedded System Diagnostics from Boot Manager

Before you begin

Run the Embedded System Diagnostics (ePSA) if your system does not boot.

Procedure

1. When the system is booting, press F11.
2. Use the up arrow and down arrow keys to select **System Utilities > Launch Diagnostics**.
The **ePSA Pre-boot System Assessment** window is displayed, listing all devices detected in the system. The diagnostics starts executing the tests on all the detected devices.

Running the Embedded System Diagnostics from the Dell Lifecycle Controller

Procedure

1. As the system boots, press F11.
2. Select **Hardware Diagnostics → Run Hardware Diagnostics**.
The **ePSA Pre-boot System Assessment** window is displayed, listing all devices detected in the system. The diagnostics starts executing the tests on all the detected devices.

System diagnostic controls

Menu

Description

Configuration

Displays the configuration and status information of all detected devices.

Results

Displays the results of all tests that are run.

System health

Provides the current overview of the system performance.

Event log

Displays a time-stamped log of the results of all tests run on the system. This is displayed if at least one event description is recorded.

CHAPTER 8

Jumpers and connectors





- [System board jumper settings](#).....196
- [System board connectors](#)..... 197
- [Disabling a forgotten password](#)..... 199

System board jumper settings

For information about resetting the password jumper to disable a password, see the [Disabling a forgotten password](#) section.

To enable the password, fit the jumper on pins 2 and 4. To disable the password, fit the jumper on pins 4 and 6. To select the configuration settings at the next system boot, fit the jumper on pins 3 and 5. To clear the configuration settings at system boot, fit the jumper on pins 1 and 3.

Table 43 System board jumper settings

Jumper	Setting	Description
PWRD_EN	 2 4 6 (default)	The password reset feature is enabled (pins 2–4).
	 2 4 6	The password reset feature is disabled (pins 4–6). The iDRAC local access is unlocked at the next AC power cycle.
NVRAM_CLR	 1 3 5 (default)	The configuration settings are retained at the next system boot (pins 3–5).
	 1 3 5	The configuration settings are cleared at system boot (pins 1–3).

System board connectors

Figure 104 System board jumpers and connectors

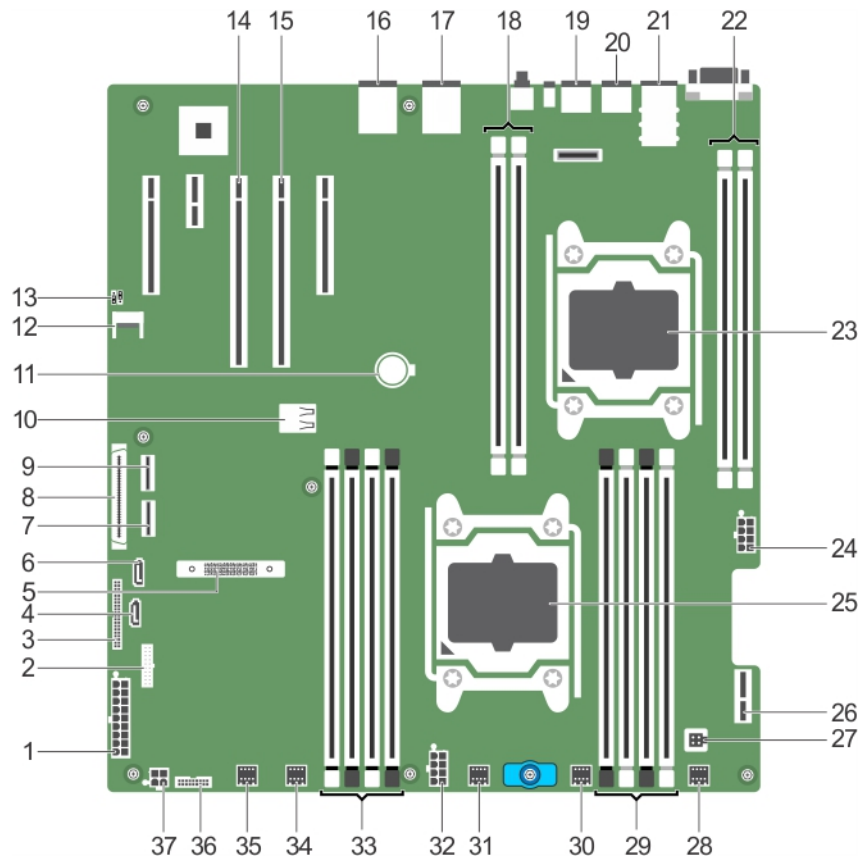

System board jumpers and connectors

Table 44 System board jumpers and connectors

Item	Connector	Description
1	SYS_PWR_CONN (P1)	24-pin power connector
2	FB_USB	Front-panel USB connector
3	PIB_CONN	Power interposer board connector
4	SATA_CDROM	SATA connector CDROM
5	MiniPERC PCIE_G3_X8 (CPU1)	Mini PERC card connector
6	SATA_TBU	SATA connector tape backup unit
7	SW_RAID_B	Software RAID connector B
8	CTRL_PNL	Control panel interface connector
9	SW_RAID_A	Software RAID connector A
10	INT_USB_3.0	Internal USB connector
11	BATTERY	Battery connector

Table 44 System board jumpers and connectors (continued)

Item	Connector	Description
12	TPM_MODULE	Trusted platform module connector
13	J_PSWD_NVRAM	For more information, see the System board jumper setting section.
14	SLOT3 PCIE_G3_X16(CPU1)	PCIe card connector 3
15	SLOT2 PCIE_G3_X16(CPU1)	PCIe card connector 2  Note: The PCIE_G3_X8 and PCIE_G3_X16 are the two different types of risers supported on R430 systems. You can install an expansion card on the system board only using expansion card riser. For more information about the installation guidelines, see the Expansion card installation guidelines section.
16	NIC4	Network connector
17	NIC3	Network connector
18	B1, B2	Memory module socket
19	USB2_3.0	USB connector
20	USB1	USB connector
21	NIC1 and NIC2	Network connector
22	B3, B4	Memory module socket
23	CPU2	Processor socket 2
24	PWR_CONN_C(P3)	8-pin power connector
25	CPU1	Processor socket 1
26	IDSDM	Internal Dual SD Module connector
27	INTRUSION	Intrusion switch connector
28	FAN6	Cooling fan connector
29	A1, A5, A2, A6	Memory module socket
30	FAN5	Cooling fan connector
31	FAN4	Cooling fan connector
32	PWR_CONN_B(P2)	8-pin power connector
33	A3, A7, A4, A8	Memory module socket
34	FAN3	Cooling fan connector
35	FAN2	Cooling fan connector
36	BP_SIG	Backplane signal connector
37	ODD_PWR	Optical disc drive connector

Disabling a forgotten password

The software security features of the system include a system password and a setup password. The password jumper enables these password features or disables them and clears any password(s) currently in use.

Before you begin

 **CAUTION** Many repairs may only be done by a certified service technician. You should only perform troubleshooting and simple repairs as authorized in your product documentation, or as directed by the online or telephone service and support team. Damage due to servicing that is not authorized by Dell is not covered by your warranty. Read and follow the safety instructions that are shipped with your product.

Procedure

1. Turn off the system, including any attached peripherals, and disconnect the system from the electrical outlet.
2. Remove the system cover.
3. Move the jumper on the system board jumper from pins 4 and 6 to pins 2 and 4.
4. Install the system cover.

The existing passwords are not disabled (erased) until the system boots with the jumper on pins 2 and 4. However, before you assign a new system and/or setup password, you must move the jumper back to pins 4 and 6.

 **Note:** If you assign a new system and/or setup password with the jumper on pins 2 and 4, the system disables the new password(s) the next time it boots.

5. Reconnect the system to its electrical outlet and turn the system on, including any attached peripherals.
6. Turn off the system, including any attached peripherals, and disconnect the system from the electrical outlet.
7. Remove the system cover.
8. Move the jumper on the system board jumper from pins 2 and 4 to pins 4 and 6.
9. Install the system cover.
10. Reconnect the system to its electrical outlet and turn the system on, including any attached peripherals.
11. Assign a new system and/or setup password.

CHAPTER 9

Troubleshooting your system

Safety first—for you and your system

 **CAUTION** Many repairs may only be done by a certified service technician. You should only perform troubleshooting and simple repairs as authorized in your product documentation, or as directed by the online or telephone service and support team. Damage due to servicing that is not authorized by Dell is not covered by your warranty. Read and follow the safety instructions that are shipped with your product.

- [Troubleshooting system startup failure](#)..... 202
- [Troubleshooting external connections](#)..... 202
- [Troubleshooting the video subsystem](#)..... 202
- [Troubleshooting a USB device](#).....202
- [Troubleshooting a serial I/O device](#)..... 203
- [Troubleshooting a NIC](#).....203
- [Troubleshooting a wet system](#).....204
- [Troubleshooting a damaged system](#)..... 205
- [Troubleshooting the system battery](#).....206
- [Troubleshooting power supply units](#)..... 206
- [Troubleshooting cooling problems](#)..... 207
- [Troubleshooting cooling fans](#).....208
- [Troubleshooting system memory](#).....208
- [Troubleshooting an internal USB key](#).....209
- [Troubleshooting an SD card](#)..... 210
- [Troubleshooting an optical drive](#)..... 211
- [Troubleshooting a hard drive](#)..... 211
- [Troubleshooting a storage controller](#).....212
- [Troubleshooting expansion cards](#)..... 213
- [Troubleshooting processors](#)..... 214
- [System messages](#)..... 214

Troubleshooting system startup failure

If you boot the system to the BIOS boot mode after installing an operating system from the UEFI Boot Manager, the system stops responding. To avoid this issue, you must boot to the same boot mode in which you installed the operating system.

For all other startup issues, note the system messages that appear on the screen.

Troubleshooting external connections

Before troubleshooting any external devices, ensure that all external cables are securely attached to the external connectors on your system before troubleshooting any external devices.

Troubleshooting the video subsystem

Procedure

1. Check the system and power connections to the monitor.
2. Check the video interface cabling from the system to the monitor.
3. Run the appropriate diagnostic test.

Results

If the tests run successfully, the problem is not related to video hardware.

If the tests fail, see the Getting help section.

Troubleshooting a USB device

Before you begin

 **Note:** Follow steps 1 to 6 to troubleshoot a USB keyboard or mouse. For other USB devices, go to step 7.

Procedure

1. Disconnect the keyboard and/or mouse cables from the system and reconnect them.
2. If the problem persists, connect the keyboard and/or mouse to another USB port on the system.
3. If the problem is resolved, restart the system, enter System Setup, and check if the non-functioning USB ports are enabled.

 **Note:** Older operating systems may not support USB 3.0.

4. Check if USB 3.0 is enabled in System Setup. If enabled, disable it and see if the issue is resolved.
5. In **iDRAC Settings Utility**, ensure that **USB Management Port Mode** is configured as **Automatic** or **Standard OS Use**.
6. If the problem is not resolved, replace the keyboard and/or mouse with a known working keyboard or mouse.

If the problem is not resolved, proceed to step 7 to troubleshoot other USB devices attached to the system.

7. Turn off all attached USB devices, and disconnect them from the system.
8. Restart the system.
9. If your keyboard is functioning, enter System Setup, verify that all USB ports are enabled on the **Integrated Devices** screen. If your keyboard is not functioning, use remote access to enable or disable the USB options.
10. Check if USB 3.0 is enabled in System Setup. If it is enabled, disable it and restart your system.
11. If the system is not accessible, reset the NVRAM_CLR jumper inside your system and restore the BIOS to the default settings. See the System board jumper setting section
12. In the **IDRAC Settings Utility**, ensure that **USB Management Port Mode** is configured as **Automatic** or **Standard OS Use**.
13. Reconnect and turn on each USB device one at a time.
14. If a USB device causes the same problem, turn off the device, replace the USB cable with a known good cable, and turn on the device.

After you finish

If all troubleshooting fails, see the Getting help section.

Troubleshooting a serial I/O device

Procedure

1. Turn off the system and any peripheral devices connected to the serial port.
2. Swap the serial interface cable with a known working cable, and turn on the system and the serial device.

If the problem is resolved, replace the interface cable with a known working cable.

3. Turn off the system and the serial device, and swap the serial device with a compatible device.
4. Turn on the system and the serial device.

After you finish

If the problem persists, see the Getting help section.

Troubleshooting a NIC

Procedure

1. Run the appropriate diagnostic test. For more information, see the Using system diagnostics section for the available diagnostic tests.
2. Restart the system and check for any system messages pertaining to the NIC controller.
3. Check the appropriate indicator on the NIC connector:
 - If the link indicator does not glow, the cable connected might be disengaged.
 - If the activity indicator does not glow, the network driver files might be damaged or missing. Install or replace the drivers as necessary. For more information, see the NIC documentation.
 - Try another known good network cable.

- If the problem persists, use another connector on the switch or hub.
4. Ensure that the appropriate drivers are installed and the protocols are bound. For more information, see the NIC documentation.
 5. Enter System Setup and confirm that the NIC ports are enabled on the **Integrated Devices** screen.
 6. Ensure that all the NICs, hubs, and switches on the network are set to the same data transmission speed and duplex. For more information, see the documentation for each network device.
 7. Ensure that all network cables are of the proper type and do not exceed the maximum length.

After you finish

If the problem persists, see the Getting help section.

Troubleshooting a wet system

Before you begin

 **CAUTION** Many repairs may only be done by a certified service technician. You should only perform troubleshooting and simple repairs as authorized in your product documentation, or as directed by the online or telephone service and support team. Damage due to servicing that is not authorized by Dell is not covered by your warranty. Read and follow the safety instructions that are shipped with your product.

Procedure

1. Turn off the system and attached peripherals, and disconnect the system from the electrical outlet.
2. Remove the system cover.
3. Remove the following components (if installed) from the system:
 - Power supply unit(s)
 - Optical drive
 - Hard drives
 - Hard drive backplane
 - USB memory key
 - Hard drive tray
 - Cooling shroud
 - Expansion card risers (if installed)
 - Expansion cards
 - Cooling fan assembly (if installed)
 - Cooling fans
 - Memory modules
 - Processor(s) and heat sink(s)
 - System board
4. Let the system dry thoroughly for at least 24 hours.
5. Reinstall the components you removed in step 3 except the expansion cards.

6. Install the system cover.
7. Turn on the system and attached peripherals.
If the problem persists, see the Getting help section.
8. If the system starts properly, turn off the system, and reinstall all the expansion cards that you removed.
9. Run the appropriate diagnostic test. For more information, see the Using system diagnostics section.

After you finish

If the tests fail, see the Getting help section.

Troubleshooting a damaged system

Before you begin

 **CAUTION** Many repairs may only be done by a certified service technician. You should only perform troubleshooting and simple repairs as authorized in your product documentation, or as directed by the online or telephone service and support team. Damage due to servicing that is not authorized by Dell is not covered by your warranty. Read and follow the safety instructions that are shipped with your product.

Procedure

1. Turn off the system and attached peripherals, and disconnect the system from the electrical outlet.
2. Remove the system cover.
3. Ensure that the following components are properly installed:
 - cooling shroud
 - expansion card risers (if installed)
 - expansion cards
 - power supply unit(s)
 - cooling fan assembly (if installed)
 - cooling fans
 - processor(s) and heat sink(s)
 - memory modules
 - hard drive carriers/cage
 - hard drive backplane
4. Ensure that all cables are properly connected.
5. Install the system cover.
6. Run the appropriate diagnostic test. For more information, see the Using system diagnostics section.

After you finish

If the problem persists, see the Getting help section.

Troubleshooting the system battery

Before you begin

 **CAUTION** Many repairs may only be done by a certified service technician. You should only perform troubleshooting and simple repairs as authorized in your product documentation, or as directed by the online or telephone service and support team. Damage due to servicing that is not authorized by Dell is not covered by your warranty. Read and follow the safety instructions that are shipped with your product.

 **Note:** If the system is turned off for long periods of time (for weeks or months), the NVRAM may lose its system configuration information. This situation is caused by a defective battery.

 **Note:** Some software may cause the system time to speed up or slow down. If the system seems to operate normally except for the time set in System Setup, the problem may be caused by a software, rather than by a defective battery.

Procedure

1. Re-enter the time and date in System Setup.
2. Turn off the system, and disconnect it from the electrical outlet for at least an hour.
3. Reconnect the system to the electrical outlet, and turn on the system.
4. Enter System Setup.

If the date and time displayed in System Setup are not correct, check the System Error Log (SEL) for system battery messages.

After you finish

If the problem persists, see the Getting help section.

Troubleshooting power supply units

Before you begin

 **CAUTION** Many repairs may only be done by a certified service technician. You should only perform troubleshooting and simple repairs as authorized in your product documentation, or as directed by the online or telephone service and support team. Damage due to servicing that is not authorized by Dell is not covered by your warranty. Read and follow the safety instructions that are shipped with your product.

Troubleshooting power source problems

Procedure

1. Press the power button to ensure that your system is turned on. If the power indicator does not glow when the power button is pressed, press the power button firmly.
2. Plug in another working power supply unit to ensure that the system board is not faulty.
3. Ensure that no loose connections exist.
For example, loose power cables.
4. Ensure that the power source meets applicable standards.
5. Ensure that there are no short circuits.

6. Have a qualified electrician check the line voltage to ensure that it meets the needed specifications.

Power supply unit problems

Procedure

1. Ensure that no loose connections exist.
For example, loose power cables.
2. Ensure that the power supply unit (PSU) handle or LED indicates that the PSU is working properly.
For more information about PSU indicators, see the Power indicator codes section.
3. If you have recently upgraded your system, ensure that the PSU has enough power to support the new system.
4. If you have a redundant PSU configuration, ensure that both the PSUs are of the same type and wattage.
You may have to upgrade to a higher wattage PSU.
5. Ensure that you use only PSUs with the Extended Power Performance (EPP) label on the back.
6. Reseat the PSU.

 **Note:** After installing a PSU, allow several seconds for the system to recognize the PSU and determine if it is working properly.

If the problem persists, see the Getting help section.

Troubleshooting cooling problems

 **CAUTION** Many repairs may only be done by a certified service technician. You should only perform troubleshooting and simple repairs as authorized in your product documentation, or as directed by the online or telephone service and support team. Damage due to servicing that is not authorized by Dell is not covered by your warranty. Read and follow the safety instructions that are shipped with your product.

Ensure that the following conditions exist:

- System cover, cooling shroud, EMI filler panel, memory module blank, or back filler bracket is not removed.
- Ambient temperature is not higher than the system specific ambient temperature.
- External airflow is not obstructed.
- A cooling fan is not removed or has not failed.
- The expansion card installation guidelines have been followed.

Additional cooling can be added by one of the following methods:

From the iDRAC web GUI:

1. Click **Hardware > Fans > Setup**.
2. From the **Fan Speed Offset** drop-down list, select the cooling level required or set the minimum fan speed to a custom value.

From F2 System Setup:

1. Select **iDRAC Settings > Thermal**, and set a higher fan speed from the fan speed offset or minimum fan speed.

From RACADM commands:

1. Run the command `racadm help system.thermalsettings`

For more information, see the Integrated Dell Remote Access User's Guide at Dell.com/idracmanuals.

Troubleshooting cooling fans

Before you begin

 **CAUTION** Many repairs may only be done by a certified service technician. You should only perform troubleshooting and simple repairs as authorized in your product documentation, or as directed by the online or telephone service and support team. Damage due to servicing that is not authorized by Dell is not covered by your warranty. Read and follow the safety instructions that are shipped with your product.

 **Note:** The fan number is referenced by the systems management software. In the event of a problem with a particular fan, you can easily identify and replace it by noting down the fan numbers on the cooling fan assembly.

1. Follow the safety guidelines listed in the Safety instructions section.
2. Follow the procedure listed in the Before working inside your system section.

Procedure

1. Reseat the fan or the fan's power cable.
2. Restart the system.

After you finish

1. Follow the procedure listed in the After working inside your system section.
2. If the problem persists, see the Getting help section.

Troubleshooting system memory

Before you begin

 **CAUTION** Many repairs may only be done by a certified service technician. You should only perform troubleshooting and simple repairs as authorized in your product documentation, or as directed by the online or telephone service and support team. Damage due to servicing that is not authorized by Dell is not covered by your warranty. Read and follow the safety instructions that are shipped with your product.

Procedure

1. If the system is operational, run the appropriate system diagnostic test. See the Using system diagnostics section for the available diagnostic tests.

If the diagnostic tests indicate a fault, follow the corrective actions provided by the diagnostic tests.

2. If the system is not operational, turn off the system and attached peripherals, and unplug the system from the power source. Wait at least for 10 seconds, and then reconnect the system to the power source.

3. Turn on the system and attached peripherals, and note the messages on the screen.
If an error message is displayed indicating a fault with a specific memory module, go to step 12.
4. Enter System Setup, and check the system memory setting. Make any changes to the memory settings, if needed.
If the memory settings match the installed memory but the problem still persists, go to step 12.
5. Turn off the system and attached peripherals, and disconnect the system from the electrical outlet.
6. Remove the system cover.
7. Check the memory channels and ensure that they are populated correctly.
 **Note:** See the system event log or system messages for the location of the failed memory module. Reinstall the memory device.
8. Reseat the memory modules in their sockets.
9. Install the system cover.
10. Enter System Setup and check the system memory setting.
If the problem is not resolved, proceed with step 11.
11. Remove the system cover.
12. If a diagnostic test or error message indicates a specific memory module as faulty, swap or replace the module with a known working memory module.
13. To troubleshoot an unspecified faulty memory module, replace the memory module in the first DIMM socket with a module of the same type and capacity.
If an error message is displayed on the screen, this may indicate a problem with the installed DIMM type(s), incorrect DIMM installation, or defective DIMM(s). Follow the on-screen instructions to resolve the problem.
14. Install the system cover.
15. As the system boots, observe any error message that is displayed and the diagnostic indicators on the front of the system.
16. If the memory problem persists, repeat step 12 through step 15 for each memory module installed.

After you finish

If the problem persists, see the Getting help section.

Troubleshooting an internal USB key

Before you begin

 **CAUTION** Many repairs may only be done by a certified service technician. You should only perform troubleshooting and simple repairs as authorized in your product documentation, or as directed by the online or telephone service and support team. Damage due to servicing that is not authorized by Dell is not covered by your warranty. Read and follow the safety instructions that are shipped with your product.

Procedure

1. Enter System Setup and ensure that the **USB key port** is enabled on the **Integrated Devices** screen.
2. Turn off the system and attached peripherals, and disconnect the system from the electrical outlet.
3. Remove the system cover.
4. Locate the USB key and reseal it.
5. Install the system cover.
6. Turn on the system and attached peripherals, and check if the USB key is functioning.
7. If the problem is not resolved, repeat step 2 and step 3.
8. Insert a known working USB key.
9. Install the system cover.

After you finish

If the problem persists, see the Getting help section.

Troubleshooting an SD card

Before you begin

 **CAUTION** Many repairs may only be done by a certified service technician. You should only perform troubleshooting and simple repairs as authorized in your product documentation, or as directed by the online or telephone service and support team. Damage due to servicing that is not authorized by Dell is not covered by your warranty. Read and follow the safety instructions that are shipped with your product.

 **Note:** Certain SD cards have a physical write-protect switch on the card. If the write-protect switch is turned on, the SD card is not writable.

Procedure

1. Enter System Setup, and ensure that the **Internal SD Card Port** is enabled.
2. Turn off the system, including any attached peripherals, and disconnect the system from the electrical outlet.
3. Remove the system cover.

 **Note:** When an SD card failure occurs, the internal dual SD module controller notifies the system. On the next restart, the system displayed a message indicating the failure. If redundancy is enabled at the time of SD card failure, a critical alert will be logged and chassis health will degrade.
4. Replace the failed SD card with a new SD card.
5. Install the system cover.
6. Reconnect the system to its electrical outlet and turn on the system, including any attached peripherals.
7. Enter System Setup, and ensure that the **Internal SD Card Port** and **Internal SD Card Redundancy** modes are set to the needed modes.

Verify that the correct SD slot is set as **Primary SD Card**.
8. Check if the SD card is functioning properly.

- If the **Internal SD Card Redundancy** option is set to **Enabled** at the time of the SD card failure, the system prompts you to perform a rebuild.

 **Note:** The rebuild is always sourced from the primary SD card to the secondary SD card.

Troubleshooting an optical drive

Before you begin

 **CAUTION** Many repairs may only be done by a certified service technician. You should only perform troubleshooting and simple repairs as authorized in your product documentation, or as directed by the online or telephone service and support team. Damage due to servicing that is not authorized by Dell is not covered by your warranty. Read and follow the safety instructions that are shipped with your product.

Procedure

- Try using a different CD or DVD.
- If the problem is not resolved, enter System Setup and ensure that the integrated SATA controller and the drive's SATA port are enabled.
- Run the appropriate diagnostic test.
- Turn off the system and attached peripherals, and disconnect the system from the electrical outlet.
- If installed, remove the bezel.
- Remove the system cover.
- Ensure that the interface cable is securely connected to the optical drive and to the controller.
- Ensure that a power cable is properly connected to the drive.
- Install the system cover.

After you finish

If the problem persists, see the Getting help section.

Troubleshooting a hard drive

Before you begin

 **CAUTION** This troubleshooting procedure can erase data stored on the hard drive. Before you proceed, back up all files on the hard drive.

 **CAUTION** Many repairs may only be done by a certified service technician. You should only perform troubleshooting and simple repairs as authorized in your product documentation, or as directed by the online or telephone service and support team. Damage due to servicing that is not authorized by Dell is not covered by your warranty. Read and follow the safety instructions that are shipped with your product.

Procedure

- Run the appropriate diagnostic test. See the Using system diagnostics section.
Depending on the results of the diagnostics test, proceed as needed through the following steps.

2. If your system has a RAID controller and your hard drives are configured in a RAID array, perform the following steps:
 - a. Restart the system and press F10 during system startup to run the Dell Lifecycle Controller, and then run the Hardware Configuration wizard to check the RAID configuration.

See the Dell Lifecycle Controller documentation or online help for information about RAID configuration.
 - b. Ensure that the hard drives are configured correctly for the RAID array.
 - c. Take the hard drive offline and reseal the drive.
 - d. Exit the configuration utility and allow the system to boot to the operating system.
3. Ensure that the needed device drivers for your controller card are installed and are configured correctly. See the operating system documentation for more information.
4. Restart the system and enter the System Setup.
5. Verify that the controller is enabled and the drives are displayed in the System Setup.

After you finish

If the problem persists, see the Getting help section.

Troubleshooting a storage controller

 **CAUTION** Many repairs may only be done by a certified service technician. You should only perform troubleshooting and simple repairs as authorized in your product documentation, or as directed by the online or telephone service and support team. Damage due to servicing that is not authorized by Dell is not covered by your warranty. Read and follow the safety instructions that are shipped with your product.

 **Note:** When troubleshooting a SAS or PERC controller, see the documentation for your operating system and the controller.

1. Run the appropriate diagnostic test. See the Using system diagnostics section.
2. Turn off the system and attached peripherals, and disconnect the system from the electrical outlet.
3. Remove the system cover.
4. Verify that the installed expansion cards are compliant with the expansion card installation guidelines.
5. Ensure that each expansion card is firmly seated in its connector.
6. Install the system cover.
7. Reconnect the system to the electrical outlet, and turn on the system and attached peripherals.
8. If the problem is not resolved, turn off the system and attached peripherals, and disconnect the system from the electrical outlet.
9. Remove the system cover.
10. Remove all expansion cards installed in the system.
11. Install the system cover.
12. Reconnect the system to the electrical outlet, and turn on the system and attached peripherals.

13. Run the appropriate diagnostic test. See the Using system diagnostics section. If the tests fail, see the Getting help section.
14. For each expansion card you removed in step 10, perform the following steps:
 - a. Turn off the system and attached peripherals, and disconnect the system from the electrical outlet.
 - b. Remove the system cover.
 - c. Reinstall one of the expansion cards.
 - d. Install the system cover.
 - e. Run the appropriate diagnostic test. See the Using system diagnostics section.

If the problem persists, see the Getting help section.

Troubleshooting expansion cards

Before you begin

 **CAUTION** Many repairs may only be done by a certified service technician. You should only perform troubleshooting and simple repairs as authorized in your product documentation, or as directed by the online or telephone service and support team. Damage due to servicing that is not authorized by Dell is not covered by your warranty. Read and follow the safety instructions that are shipped with your product.

 **Note:** When troubleshooting an expansion card, you also have to see the documentation for your operating system and the expansion card.

Procedure

1. Run the appropriate diagnostic test. See the Using system diagnostics section.
2. Turn off the system and attached peripherals, and disconnect the system from the electrical outlet.
3. Remove the system cover.
4. Ensure that each expansion card is firmly seated in its connector.
5. Install the system cover.
6. Turn on the system and attached peripherals.
7. If the problem is not resolved, turn off the system and attached peripherals, and disconnect the system from the electrical outlet.
8. Remove the system cover.
9. Remove all expansion cards installed in the system.
10. Install the system cover.
11. Run the appropriate diagnostic test. See the Using system diagnostics section.
If the tests fail, see the Getting help section.
12. For each expansion card you removed in step 8, perform the following steps:
 - a. Turn off the system and attached peripherals, and disconnect the system from the electrical outlet.
 - b. Remove the system cover.
 - c. Reinstall one of the expansion cards.

- d. Install the system cover.
- e. Run the appropriate diagnostic test. See the Using system diagnostics section.

After you finish

If the problem persists, see the Getting help section.

Troubleshooting processors

Before you begin

 **CAUTION** Many repairs may only be done by a certified service technician. You should only perform troubleshooting and simple repairs as authorized in your product documentation, or as directed by the online or telephone service and support team. Damage due to servicing that is not authorized by Dell is not covered by your warranty. Read and follow the safety instructions that are shipped with your product.

Procedure

1. Run the appropriate diagnostics test. See the Using system diagnostics section.
2. Turn off the system and attached peripherals, and disconnect the system from the electrical outlet.
3. Remove the system cover.
4. Ensure that the processor and heat sink are properly installed.
5. Install the system cover.
6. Run the appropriate diagnostic test. See the Using system diagnostics section.
7. If the problem persists, see the Getting help section.

System messages

For a list of event and error messages generated by the system firmware and agents that monitor system components, see the Dell Event and Error Messages Reference Guide at [Dell.com/openmanagemanuals](https://www.dell.com/support/manuals) > **OpenManage software**.

Warning messages

A warning message alerts you to a possible problem and prompts you to respond before the system continues a task. For example, before you format a hard drive, a message warns you that you may lose all data on the hard drive. Warning messages usually interrupt the task and need you to respond by typing y (yes) or n (no).

 **Note:** Warning messages are generated by either the application or the operating system. For more information, see the documentation that shipped with the operating system or application.

Diagnostic messages

The system diagnostic utility will generate messages if there are errors detected when you run diagnostic tests on your system. For more information about system diagnostics, see the Using system diagnostics section.

Alert messages

The systems management software generates alert messages for your system. Alert messages include information, status, warning, and failure messages for drive, temperature, fan, and power

conditions. For more information, see the systems management software documentation links listed in the Documentation resources section of this manual.

CHAPTER 10

Getting help

- [Contacting Dell](#)..... 218
- [Documentation feedback](#)..... 218
- [Accessing system information by using QRL](#)..... 218

Contacting Dell

Dell provides several online and telephone-based support and service options. If you do not have an active internet connection, you can find contact information about your purchase invoice, packing slip, bill, or Dell product catalog. Availability varies by country and product, and some services may not be available in your area. To contact Dell for sales, technical assistance, or customer-service issues:

Procedure

1. Go to Dell.com/support.
2. Select your country from the drop-down menu on the lower right corner of the page.
3. For customized support:
 - a. Enter your system Service Tag in the **Enter your Service Tag** field.
 - b. Click **Submit**.

The support page that lists the various support categories is displayed.
4. For general support:
 - a. Select your product category.
 - b. Select your product segment.
 - c. Select your product.

The support page that lists the various support categories is displayed.
5. For contact details of Dell Global Technical Support:
 - a. Click [Global Technical Support](#).
 - b. The **Contact Technical Support** page is displayed with details to call, chat, or e-mail the Dell Global Technical Support team.

Documentation feedback

Click the **Feedback** link in any of the Dell documentation pages, fill out the form, and click **Submit** to send your feedback.

Accessing system information by using QRL

You can use the Quick Resource Locator (QRL) to get immediate access to the information about your system.

Before you begin

Ensure that your smartphone or tablet has the QR code scanner installed.
The QRL includes the following information about your system:

About this task

- How-to videos
- Reference materials, including the Owner's Manual, LCD diagnostics, and mechanical overview
- Your system service tag to quickly access your specific hardware configuration and warranty information
- A direct link to Dell to contact technical assistance and sales teams

Procedure

1. Go to Dell.com/QRL and navigate to your specific product or
2. Use your smartphone or tablet to scan the model-specific Quick Resource (QR) code on your Dell PowerEdge system or in the Quick Resource Locator section.

Quick Resource Locator for the PowerEdge R430 system**Figure 105** Quick Resource Locator

