

# **Dell EMC PowerSwitch Z9332F-ON**

## **Installation Guide**

March 2022

## Notes, cautions, and warnings

 **NOTE:** A NOTE indicates important information that helps you make better use of your product.

 **CAUTION:** A CAUTION indicates either potential damage to hardware or loss of data and tells you how to avoid the problem.

 **WARNING:** A WARNING indicates a potential for property damage, personal injury, or death.

<b>Chapter 1: About this guide</b> .....	<b>5</b>
Related documents.....	5
Information symbols.....	6
<b>Chapter 2: The Z9332F-ON switch</b> .....	<b>7</b>
Introduction.....	7
Features.....	8
Physical dimensions.....	9
LED display.....	9
LED behavior.....	9
Prerequisites.....	10
Z9332F-ON switch configurations.....	11
Luggage tag.....	11
<b>Chapter 3: Site preparations</b> .....	<b>12</b>
Site selection.....	12
Cabinet placement.....	12
Rack mounting.....	13
Switch ground.....	13
Fans and airflow.....	13
Power.....	13
Storing components.....	14
<b>Chapter 4: Z9332F-ON switch installation</b> .....	<b>15</b>
Unpack.....	15
Unpacking Steps.....	15
Ground cable.....	16
Rack or cabinet hardware installation.....	16
Rail installation.....	17
Optics installation.....	20
Optics removal.....	20
Switch start-up.....	21
After switch placement.....	21
Switch replacement.....	21
<b>Chapter 5: Power supplies</b> .....	<b>23</b>
Components.....	23
AC power supply installation.....	24
AC power supply replacement.....	24
<b>Chapter 6: Fans</b> .....	<b>26</b>
Components.....	26
Fan module installation.....	27
Fan module replacement.....	27

<b>Chapter 7: Management ports.....</b>	<b>28</b>
RJ45 console port access.....	28
USB storage mount.....	28
<b>Chapter 8: Before you install an operating system.....</b>	<b>30</b>
Check your switch.....	31
ONIE service discovery.....	31
<b>Chapter 9: Specifications.....</b>	<b>32</b>
Chassis physical design.....	32
IEEE standards.....	33
Agency compliance.....	33
USA Federal Communications Commission statement.....	33
European Union EMC directive conformance statement.....	34
India.....	34
Japan VCCI compliance for class A equipment.....	34
Korean certification of compliance.....	35
Safety standards and compliance agency certifications.....	35
Electromagnetic compatibility .....	36
Product recycling and disposal.....	36
<b>Chapter 10: Dell EMC support.....</b>	<b>38</b>

# About this guide

This guide provides site preparation recommendations, step-by-step procedures for rack mounting and desk mounting your switch, inserting modules, and connecting to a power source.

**CAUTION:** To avoid electrostatic discharge (ESD) damage, wear grounding wrist straps when handling this equipment.

**NOTE:** Only trained and qualified personnel can install this equipment. Read this guide before you install and power up this equipment. This equipment contains two power cables. Disconnect both power cables before servicing.

**NOTE:** This equipment contains optical transceivers, which comply with the limits of Class 1 laser radiation.



Figure 1. Class 1 laser product tag

**NOTE:** When no cable is connected, visible and invisible laser radiation may emit from the aperture of the optical transceiver ports. Avoid exposure to laser radiation. Do not stare into open apertures.

**NOTE:** Read this guide before unpacking the switch. For unpacking instructions, see [Unpack](#).

## Regulatory

Marketing model Z9332F-ON is represented by the regulatory model E49W and the regulatory type E49W001.

### Topics:

- [Related documents](#)
- [Information symbols](#)

## Related documents

For more information about the Z9332F-ON switch, see the following documents:

- *Dell EMC SmartFabric OS10 User Guide*
- *Dell EMC SmartFabric OS10 Release Notes*
- *Dell EMC PowerSwitch Z9332F-ON Setup Guide*
- *Dell EMC PowerSwitch Z9332F-ON Release Notes*
- *Enterprise SONiC Distribution by Dell Technologies User Guide*
- *Release Notes for Enterprise SONiC Distribution by Dell Technologies*

**NOTE:** To access product documentation and resources that might be helpful to install, configure, and troubleshoot the specific Dell EMC switch, see the [Dell EMC Networking Hardware OS10 Info Hub](#). For all other resources, see Dell EMC support: [www.dell.com/support](http://www.dell.com/support).

# Information symbols

This book uses the following information symbols:

 **NOTE:** The **Note** icon signals important operational information.

 **CAUTION:** The **Caution icon** signals information about situations that could result in equipment damage or loss of data.

 **NOTE:** The **Warning** icon signals information about hardware handling that could result in injury.

 **NOTE:** The **ESD Warning** icon requires that you take electrostatic precautions when handling the device.

# The Z9332F-ON switch

The following sections describe Z9332F-ON switch:

## Topics:

- [Introduction](#)
- [Features](#)
- [Physical dimensions](#)
- [LED display](#)
- [Prerequisites](#)
- [Z9332F-ON switch configurations](#)
- [Luggage tag](#)

## Introduction

The Z9332F-ON switch is a one rack-unit, full-featured fixed 10/25/40/50/100/200/400 GbE data center switch with 400 GbE optical interfaces for data center leaf aggregation. The Z9332F-ON supports 32 QSFP56-DD 400 GbE ports and two SFP+ ports.

This switch is also usable as 25/50/100GbE switch using 25/50/100 GbE breakout for connections to switches, servers, and storage.

**i** **NOTE:** For 8x breakout only: if you use any top port as the 8x breakout port, the port directly below the 8x breakout port only breaks out as follows:

- 400 GbE: 1 x breakout to one 400 GbE interface
- 100 GbE: 1 x breakout to one 100 GbE interface
- 40 GbE: 1 x breakout to one 40 GbE interface

**i** **NOTE:** DC power is not supported.

**i** **NOTE:** AC power requires HighLine 200–240 VAC support. Using 120 VAC does not provide adequate power for the system.

The Z9332F-ON switch supports the following optic configurations:

- 32 x 40 GbE
- 32 x 100 GbE
- 32 x 400 GbE—QSFP56-DD
- 64 x 40 GbE—QSFP56-DD > 2 x QSFP+
- 64 x 100 GbE—QSFP56 > 2 x QSFP28
- 128 x 25 GbE
- 128 x 10 GbE
- 128 x 100 GbE

**Table 1. Port breakout**

Port	Size	Breakout
QSFP56-DD	10 G	1, 4, or 8
QSFP56-DD	25 G	1, 4, or 8
QSFP56-DD	40 G	1 or 2
QSFP56-DD	100 G	1, 2, or 4

**Table 1. Port breakout (continued)**

Port	Size	Breakout
SFP+	1G & 10 G	2

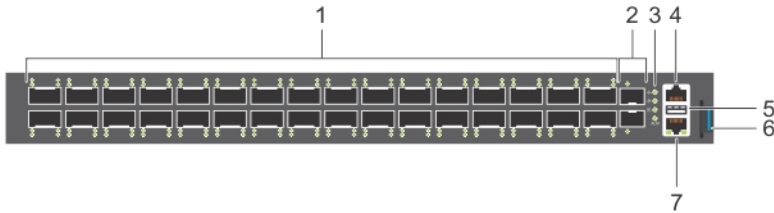

- |                                       |                          |
|---------------------------------------|--------------------------|
| 1. Thirty-two 400 GbE QSFP56-DD ports | 2. Two 10 GbE SFP+ ports |
| 3. LED Status Icons                   | 4. RJ45 console port     |
| 5. USB Type A                         | 6. Luggage tag           |
| 7. RJ45 Ethernet port                 |                          |

The Z9332F-ON switch has one RJ45 serial console port, one 10/100/1000 Base-T Ethernet management port, and one USB type-A port for the external storage. Management ports are on the I/O-side of the switch.

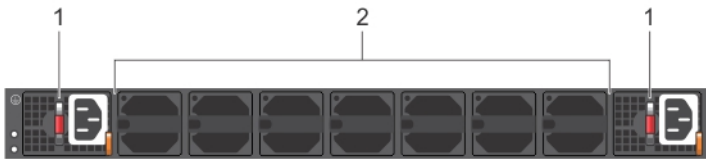

1. AC PSU1
2. Fan modules

## Features

The Z9332F-ON switch offers the following features:

- Thirty-two 400 GbE QSFP56-DD ports with QSFP28 support
- Two 10 GbE SFP+ ports
- One RJ45 console port
- One USB Type A port for more file storage
- Broadwell-DE central processing unit (CPU), 2 C, 2.2 GHz, 16 GB DDR3, 64 GB solid-state drive (SSD)
- One 10/100/1000BaseT Ethernet management port
- Temperature monitoring
- Software-readable thermal monitor
- Real-time clock (RTC) support
- Two hot-pluggable redundant PSUs
- Seven hot-pluggable replaceable fan modules
- Power management monitoring

# Physical dimensions

The Z9332F-ON switch have the following physical dimensions:

- 17.26 x 25.88 x 1.70 inches (W x D x H)
- 438.5 x 657.5 x 43.1 mm (W x D x H)

# LED display

The Z9332F-ON switch includes LED displays on the I/O side of the switch. This section describes open networking installation environment (ONIE) LED behaviors. Some LED behaviors may change after you install your software.

# LED behavior

The following Z9332F-ON switch LED behavior is seen during start up:

**NOTE:** Although each port has four LEDs, only one LED indicates switch status. The other three LEDs are intentionally off.

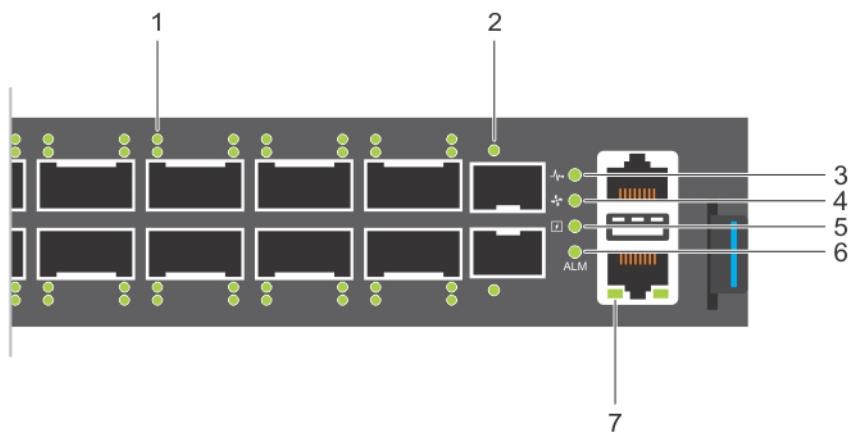

- |                           |                       |
|---------------------------|-----------------------|
| 1. Port Activity LEDs     | 2. Port Activity LEDs |
| 3. System LED             | 4. Fan LED            |
| 5. Power Supply LED       | 6. Alarm LED          |
| 7. RJ45 Ethernet Port LED |                       |

**NOTE:** For an ONIE-installed switch, after ONIE boots, the LED flashes 1 Hz green and yellow.

**Table 2. Z9332F-ON switch LED behavior**

LED	Description
System Status/Health LED	<ul style="list-style-type: none"> <li>• Solid green—Normal operation</li> <li>• Flashing green—Booting</li> <li>• Solid yellow—Major alarm. For example, thermal sensor reached the critical temperature</li> <li>• Flashing yellow—Minor alarm. For example, one PSU or fan failed.</li> </ul>
Fan LED	<ul style="list-style-type: none"> <li>• Off—No fan present</li> <li>• Solid Green—Normal operation and all fans present</li> </ul>

**Table 2. Z9332F-ON switch LED behavior (continued)**

LED	Description
	<ul style="list-style-type: none"> <li>● Solid yellow—Any one fan is absent or any fan status not in a normal status</li> </ul>
Power Supply LED	<ul style="list-style-type: none"> <li>● Off—No power</li> <li>● Solid green—Normal operation and all PSUs are present</li> <li>● Solid yellow—One PSU is absent or any one PSU status is not in a normal status.</li> </ul>
Alarm LED	<ul style="list-style-type: none"> <li>● Off—No power</li> <li>● Solid green—No alarm</li> <li>● Solid yellow—Critical alarm</li> <li>● Flashing yellow, 4 Hz—Major alarm</li> <li>● Flashing yellow, 1 Hz—Minor alarm</li> </ul>

**Table 3. System management Ethernet port LEDs**



LED	Description
Link LED	<ul style="list-style-type: none"> <li>● Off—No link</li> <li>● Solid green—Link operating at a maximum speed, autonegotiated/forced to 1000 MBase-T mode</li> </ul>
Activity LED	<ul style="list-style-type: none"> <li>● Off—No activity</li> <li>● Flashing green—Port activity</li> </ul>

**Table 4. Z9332F-ON QSFP56-DD port LEDs**

LED	Description
Link/Activity LED	<ul style="list-style-type: none"> <li>● Off—No link/activity</li> <li>● Solid green—At least one port is operationally up</li> <li>● Flashing green—At least one port is operationally up and has activity</li> </ul>

## Prerequisites

The following is a list of components that are required for successful switch installation:

-  **NOTE:** DC power is not supported.
-  **NOTE:** AC power requires HighLine 200 VAC to 240 VAC support. You cannot use 120 VAC.
-  **NOTE:** For detailed installation instructions, see [Site preparations](#) and [Z9332F-ON switch configurations](#).
- Z9332F-ON switch or multiple switches, if stacking
- AC country- and regional-specific cables to connect the AC power source to each of the AC power supplies
- Rail mounting brackets for rack installation, included
- Screws for rack installation, not included
- #1 and #2 Phillips screw drivers, not included
- Torx screwdriver, not included
- Ground cable screws for L-bracket, included
- Copper/fiber cables

Other optional components are:

- Ground cable and lug
- Extra mounting brackets
- Extra power supply unit
- Extra fan module

# Z9332F-ON switch configurations

You can order the Z9332F-ON switch in several different configurations.

- Z9332F-ON AC Normal Airflow switch—one U, 32 x 400 GbE QSFP56-DD ports, two SFP+ ports, two AC power supplies, and seven fan subsystems
- Fan with airflow from the I/O side to the PSU side
- AC power supply with airflow from the I/O side to the PSU side

## Luggage tag

The switch has a pull-out tag, known as a luggage tag, on the I/O-side of the switch. The front of the luggage tag includes switch ID information. The back of the luggage tag includes a QRL that takes you to a How-To site where you can watch videos about racking the switch, replacing components, configuring port channels, and so on.

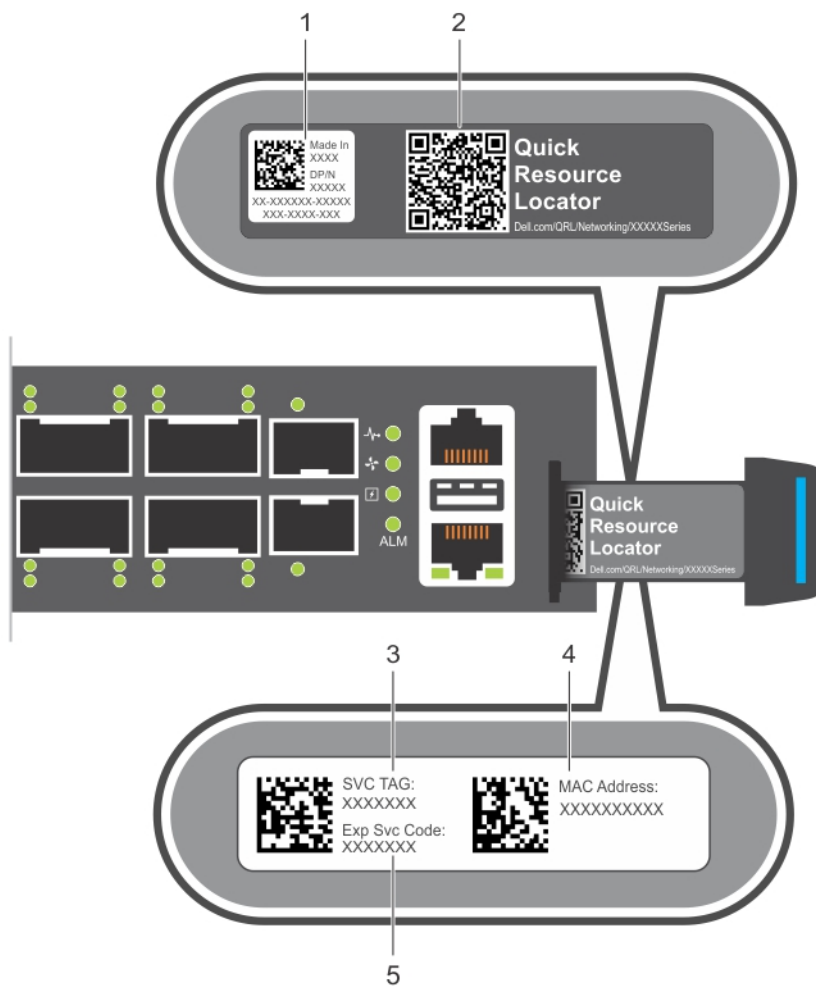

1. Switch QRL
2. Dell QRL
3. Service tag
4. MAC address
5. Express service code

# Site preparations

The Z9332F-ON switch is suitable for installation as part of a common bond network (CBN).

You can install the switch in:

- Network telecommunication facilities
- Data centers
- Other locations where the National Electric Code (NEC) applies

**i** **NOTE:** Install the switch into a rack or cabinet before installing any additional components such as cables or optics.

## Topics:

- [Site selection](#)
- [Cabinet placement](#)
- [Rack mounting](#)
- [Switch ground](#)
- [Fans and airflow](#)
- [Power](#)
- [Storing components](#)

## Site selection

Install the switch equipment in restricted access areas.

A restricted access area is one in which service personnel can only gain access using a special tool, lock, key or other means of security. The authority responsible for the location controls access to the restricted area.

Ensure that the area where you install your switch meets the following safety requirements:

- Near an adequate power source. Connect the switch to the appropriate branch circuit protection according to your local electrical codes.
- Switch environmental temperature range is from 0° to 45°C (32° to 113°F).
- Relative humidity is from 5 to 90 percent noncondensing.
- In a dry, clean, well-ventilated, and temperature-controlled room, away from heat sources such as hot air vents or direct sunlight
- Away from sources of severe electromagnetic noise
- Inside the restricted access area that is positioned in a rack or cabinet, or on a desktop with adequate space in the front, back, and sides for proper ventilation and access
- Install the switch in Information Technology Rooms in accordance with Article 645 of the National Electrical Code and NFPA 75.

For more information about switch storage and environmental temperatures, see [Specifications](#).

## Cabinet placement

Install the Z9332F-ON switch only in indoor cabinets designed for use in a controlled environment.

Do not install the switch in outside cabinets. For cabinet placement requirements, see [Site selection](#).

The cabinet must meet minimum size requirements. Airflow must be in accordance with the Electronic Industries Alliance (EIA) standard. Ensure that there is a minimum of 5 inches (12.7 cm) between the intake and exhaust vents and the cabinet wall.

## Rack mounting

When you prepare your equipment rack, ensure that the rack is grounded.

Ground the equipment rack to the same ground point the power service in your area uses. The ground path must be permanent.

## Switch ground

Dell Technologies recommends you ground your switch. Use the Z9332F-ON switch in a common bond network (CBN).

Connect the grounding cables as described in [Z9332F-ON switch installation](#).

**NOTE:** For an AC-powered switch, although the third conductor of the AC power cable provides a ground path, Dell Technologies recommends grounding your switch with a dedicated ground wire.

## Fans and airflow

Fan installation is done as part of the factory installation. The Z9332F-ON switch supports AC PSU with fan airflow from the I/O to the PSU.

The fans ship preinstalled with airflow from the I/O to the PSU. Optionally, you can order and install fans with airflow from the PSU to the I/O.

- Fan airflow from the I/O to the PSU—normal
- Fan airflow from the PSU to the I/O—reverse

**CAUTION:** Switches with fan airflow from the PSU to the I/O—reverse airflow—are subject to tighter restrictions for power consumption on cables and optics that are used for 400 GbE ports. Reverse airflow switches do not support high-power cables or optics. 400 GbE transceivers and active cables may exceed the supported threshold.

**CAUTION:** Review the optics specification sheet to understand which models support airflow from the I/O to the PSU (normal) and which support airflow from the PSU to I/O (reverse).

**NOTE:** Use a single type of airflow fan in your switch. Do not mix reverse and normal airflows in a single switch.

For proper ventilation, position the switch in an equipment rack or cabinet with a minimum of 5 inches (12.7 cm) of clearance around the exhaust vents. When you install two Z9332F-ON switches near each other, to permit proper airflow, position the two switches at least 5 inches (12.7 cm) apart. The fan speed varies based on internal temperature monitoring. The Z9332F-ON switch never intentionally turns off the fans.

For more information, see [Fans](#).

## Power

To connect the switch to the applicable power source, use the appropriate power cable. An AC power cable is included with each PSU.

When installing AC switches, follow the requirements of the National Electrical Code, ANSI/NFPA 70, where applicable.

The switch is powered-up when you connect the power cable between the switch and the power source. For more information, see [Power supplies](#).

**CAUTION:** Always disconnect the power cable before you service the power supply slots. The switch has multiple power cables. Before servicing, ensure that all power cords are disconnected.

**CAUTION:** On an AC switch, use the power supply cord as the main disconnect device. Ensure that the socket-outlet is located and installed near the equipment and is easily accessible.

**NOTE:** PSU airflow must match the airflow direction of the fans. The fans ship preinstalled with airflow from the I/O to the PSU. Optionally, you can order and install fans with airflow from the PSU to the I/O.

 **NOTE:** Module power is software that is controlled. You do not see module LEDs when the switch powers up in ONIE.

## Storing components

If you do not install your Z9332F-ON switch and components immediately, properly store the switch and all components using these guidelines:

- Storage location temperature must remain constant. The storage range is from -40°C to 70°C (-40° to 158°F).
- Store on a dry surface or floor, away from direct sunlight, heat, and air conditioning ducts.
- Store in a dust-free environment.

 **NOTE:** ESD damage can occur when components are mishandled. Always wear an ESD-preventive wrist or heel ground strap when handling the Z9332F-ON switch and accessories. After you remove the original packaging, place the Z9332F-ON switch and components on an anti-static surface.

# Z9332F-ON switch installation

To install the Z9332F-ON switch, complete the installation procedures in the order presented in this chapter.

Always handle the switch and components with care. Avoid dropping the switch or its field replaceable units (FRUs).

**NOTE:** ESD damage can occur if components are mishandled. Always wear an ESD-preventive wrist or heel ground strap when handling the Z9332F-ON switch and components. As with all electrical devices of this type, take all the necessary safety precautions to prevent injury when installing this switch.

## Topics:

- [Unpack](#)
- [Ground cable](#)
- [Rack or cabinet hardware installation](#)
- [Rail installation](#)
- [Optics installation](#)
- [Switch start-up](#)
- [After switch placement](#)
- [Switch replacement](#)

## Unpack

**NOTE:** Before unpacking the switch, inspect the container and immediately report any evidence of damage.

When unpacking the switch, make sure that the following items are included:

- One Z9332F-ON switch
- Two sets of rail kits, no tools needed
- One RJ45 to DB-9 female cable
- Two hot-swappable PSUs
- Seven hot-swappable fan units
- Two country- and region-specific AC power cables
- *Dell EMC PowerSwitch Z9332F-ON Set-up Guide*
- *Safety and Regulatory Information*
- *Warranty and Support Information*

## Unpacking Steps

Unpack the system carefully.

1. Place the container on a clean, flat surface and cut all straps securing the container.
2. Open the container or remove the container top.
3. Carefully remove the switch from the container and place it on a secure and clean surface.
4. Remove all packing material.
5. Inspect the product and accessories for damage.

# Ground cable

To attach a ground cable to the switch, use the included M4 screws.

**NOTE:** For an AC-powered switch, although the third conductor of the AC power cable provides a ground path, Dell Technologies recommends grounding your switch with a dedicated ground wire.

The ground cable and ground lug are not included. The grounding lugs must be a UL-recognized, crimp-type lug.

**CAUTION:** Grounding conductors *must* be made of copper. Do not use aluminum conductors.

**NOTE:** Coat the one-hole lug with an antioxidant compound before crimping. Also, bring any unplated mating surfaces to a shiny finish and coat with an antioxidant before mating. Plated mating surfaces must be clean and free from contamination.

**NOTE:** The rack installation ears are not suitable for grounding.

To connect the ground cable to the switch:

1. Cut your user-supplied ground cable to the wanted length.  
The cable length must facilitate proper operation of the fault interrupt circuits. Use the shortest cable route allowable.
2. Crimp the ground cable inside the user-supplied ground lug.
3. Attach the other end of the ground cable to a suitable ground point such as the rack or cabinet.  
The rack installation ears are not a suitable grounding point.

# Rack or cabinet hardware installation

You may either place the switch on a rack shelf or mount the switch directly into a 19" wide, EIA-310 E-compliant rack. Rack mounting for the Z9332F-ON switch includes four-post, two-post, round threaded holes, or square holes. The rails system is provided for 1U front-rack and two-post installations.

**WARNING:** This document is a condensed reference. Read the safety instructions in your *Safety, Environmental, and Regulatory* information booklet before you begin.

**NOTE:** The figures in this document are not intended to represent a specific switch.

**NOTE:** Do not use the mounted rails as a shelf or a workplace.

## Rack mount safety considerations

- Rack loading—Overloading or uneven loading of racks may result in shelf or rack failure, possibly damaging the equipment and causing personal injury. Stabilize racks in a permanent location before loading begins. Mount the components starting at the bottom of the rack, and then work to the top. Do not exceed the load rating of your rack.
- Power considerations—Connect only to the power source specified on the unit. When you install multiple electrical components in a rack, ensure that the total component power ratings do not exceed the circuit capabilities. Overloaded power sources and extension cords present fire and shock hazards
- Elevated ambient temperature—If installed in a closed rack assembly, the operating temperature of the rack environment may be greater than the room ambient temperature. Use care not to exceed the 45°C (113°F) maximum ambient temperature of the switch.
- Reduced air flow—Install the equipment in the rack so that the amount of airflow required for safe operation of the equipment is not compromised.
- Reliable earthing—Maintain reliable earthing of rack-mounted equipment. Pay particular attention to the supply connections other than the direct connections to the branch circuit, for example, use of power strips.
- Do not mount the equipment with the back panel facing downward.

# Rail installation

Complete the switch installation in the following order:

1. Attach the inner rails to the switch.
2. Attach the outer rails to the four-post rack.
3. Slide the switch into the rack.

To install the switch:

1. Remove the rails from the shipping container.
2. Loosen the thumbscrew at the front of the rail assembly.

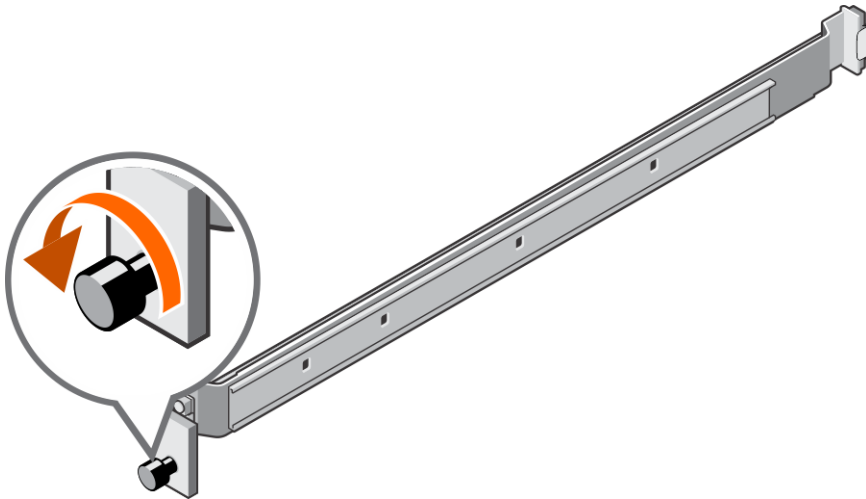

3. Pull the inner rail out of the rail assembly.

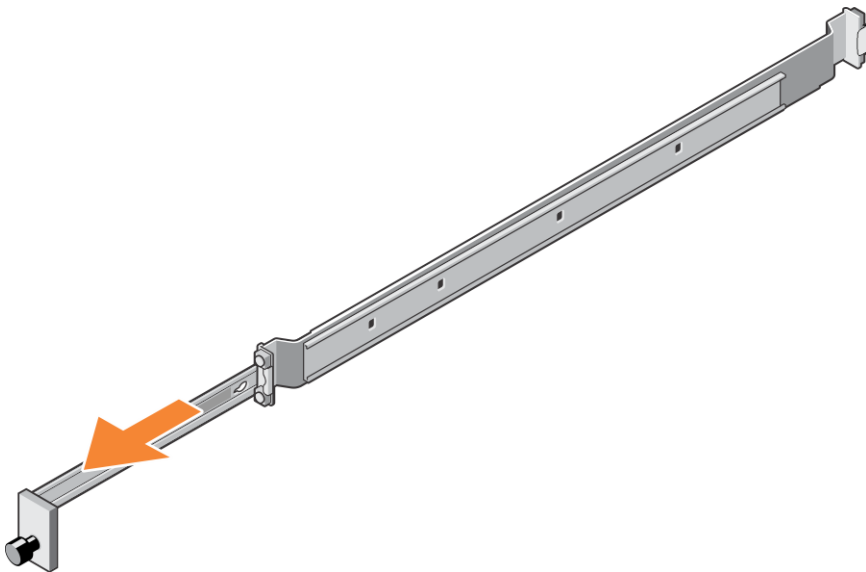

4. Slide the white-plastic lever towards the thumbscrew to separate the inner and outer rails.  
The lever is marked with a directional arrow.

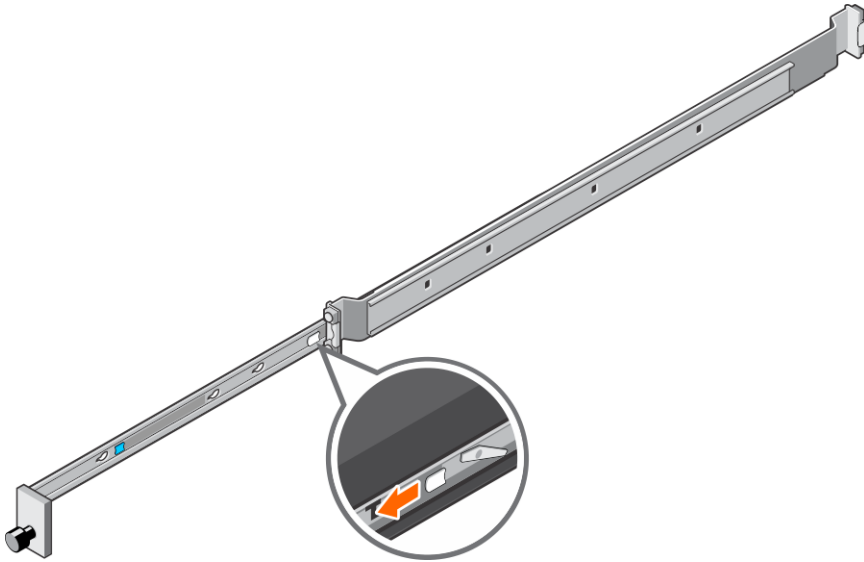

5. Line up the inner rail with the mounting heads on the switch and attach the rail to the switch. Slide the rail back until it locks into place.

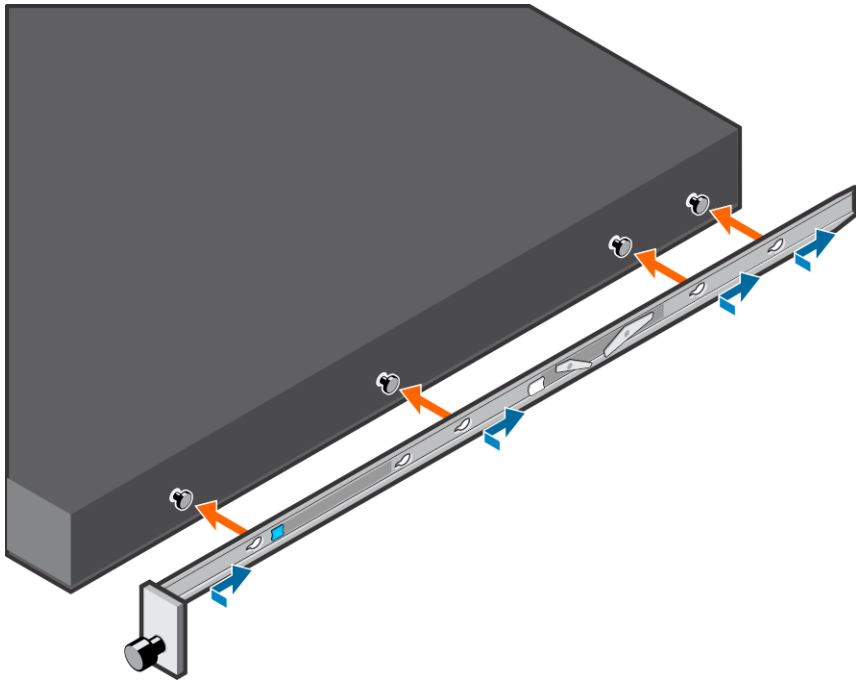

6. Repeat with the second rail.

**NOTE:** For the outer rack rails, the white latch is on the back of the rail and the black latch is on the front of the rail.

7. Start with the outer-rail rear tabs at the back of the rack rail and align the two tabs with the two rear rackmount slots. Position the white latch behind the back rack rail.



8. Push the outer rail toward the backside of the rack until the rear tabs snap into the rack. The white latch snaps into place in back of the rack post.



9. Start with the outer-rail front tabs in front of the rack rail and align the two tabs with two front rackmount slots. Position the black latch in front of the rack rail.
10. Pull the inner rail toward the frontside of the rack until the front tabs snap into the rack. The black latch snaps into place in front of the rack post.



11. Slide the switch inner rails into the rack outer rails.
12. Slide the blue-plastic lever towards the rear of the rack to fully insert the switch in the rack. You can pull or push the blue-plastic lever as it is bi-directional.
13. Tighten the front thumbscrew on each rail.

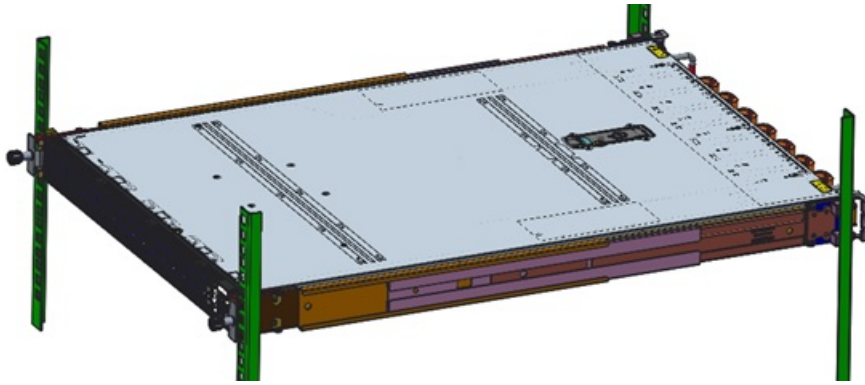

To remove the switch, loosen the thumbscrews, lift the rail latch, and slide the switch forward. After the switch is almost removed, slide the white-plastic lever towards the thumbscrews to unlock and remove the switch.

To remove the rack rails from the rack, open the white back latch, pull the rail forward and remove the back rail tabs from the two rear rack rail slots. Next open the black front latch, push the rail back and remove the front rail tabs from the front rack rail slots.

## Optics installation

The Z9332F-ON switch has QSFP56-DD and SFP+ optical ports.

For a list of supported optics, see the specification sheets at [www.dell.com/support](http://www.dell.com/support) or contact your Dell EMC Sales representative.

**CAUTION:** Switches with fan airflow from the PSU to the I/O—reverse airflow—are subject to tighter restrictions for power consumption on cables and optics that are used for 400 GbE ports. Reverse airflow switches do not support high-power cables or optics. 400 GbE transceivers and active cables may exceed the supported threshold.

**CAUTION:** Review the optics specification sheet to understand which models support airflow from the I/O to the PSU (normal) and which support airflow from the PSU to I/O (reverse).

**CAUTION:** Use caution when inserting or removing QSFP-DD optics.

**CAUTION:** ESD damage can occur if components are mishandled. Always wear an ESD-preventive wrist or heel ground strap when handling the Z9332F-ON switch and components.

**WARNING:** When working with optical fibers, follow all warning labels and always wear eye protection. Never look directly into the end of a terminated or unterminated fiber or connector as it may cause eye damage.

1. Position the optic to enter the port correctly.  
The optic has a key that prevents it from being inserted incorrectly.
2. Insert the optic into the port until it gently snaps into place.

**NOTE:** When you cable the ports, be sure not to interfere with the airflow from the small vent holes above and below the ports.

## Optics removal

Remove an optic by pushing the tab on the optic and sliding the optic from the port.

When removing optics with direct attach cables (DACs) from the port, pull the release tab firmly and steadily. Before pulling the release tab, you may need to gently push the optic into the port to ensure that it is seated properly. Do not jerk or tug repeatedly on the tab.

# Switch start-up

Supply power to the Z9332F-ON switch after it is mounted in a rack or cabinet.

Dell Technologies recommends reinspecting your switch before powering it up. Verify the following:

- Optional: The equipment is properly secured to the rack and properly grounded.
- Optional: The equipment rack is properly mounted and grounded.
- The ambient temperature around the unit, which may be higher than the room temperature, is within the limits that are specified for the Z9332F-ON switch.
- There is sufficient airflow around the unit.
- The input circuits are correctly sized for the loads and that you use sufficient overcurrent protection devices.

 **CAUTION:** Do not start up the switch if a fan module is not installed.

 **NOTE:** A US AC power cable is included for powering up an AC power supply. You must order all other power cables separately.

 **NOTE:** ESD damage can occur if components are mishandled. Always wear an ESD-preventive wrist or heel ground strap when handling the Z9332F-ON switch and components.

## Start up sequence

When the switch powers up, the fans immediately come on at high speed. The fan speed slows as the switch continues to boot.

## After switch placement

After you have securely installed and powered on the Z9332F-ON switch:

- For OS10 Networking operating system documentation and resources, see the [Dell EMC Networking OS10 Info Hub](#).
- For ONIE documentation and resources, see [www.onie.org](http://www.onie.org).

 **NOTE:** If necessary, to upgrade your software or firmware images, go to the *Drivers and Downloads* page for your switch at [www.dell.com/support](http://www.dell.com/support).

## Switch replacement

The following steps describe removing and replacing a switch with an identical replacement switch. For further assistance when replacing a switch, contact your Dell EMC support representative.

 **NOTE:** Some steps do not apply if you are replacing a different switch or non-Dell EMC switch.

 **NOTE:** ESD damage can occur when components are mishandled. Always wear an ESD-preventive wrist or heel ground strap when handling the switch and accessories. After you remove the original packaging, place the switch and components on an anti-static surface.

1. Back up the switch configuration to your back-up computer or laptop TFTP server.  
`OS10# copy config://startup.xml config://<backup file name>`
2. Disconnect the power source.
3. Label and remove all cables.
4. Remove the switch from the rack.  
At the same time, press in the two side-release bars on the switch and slide the switch forward.  
If you are using the fan trays or PSUs in the replacement switch, remove them from the switch.
5. Unpack the new switch.  
For more information, see [Unpack](#).
6. Install the new switch in your rack or cabinet.

For detailed installation instructions, see [Z9332F-ON switch installation](#).

If you are using the fan trays or PSUs from the removed switch, reinsert them in the replacement switch.

7. Connect all the cables.

8. Power on the switch.

For more information, see [Switch start up](#).

9. Establish a connection to the switch CLI.

10. Confirm that the software version of the replacement switch is the same as the previously installed switch.

```
show version
```

If the software versions do not match, upgrade the replacement switch software using the procedure included with the firmware download.

11. Copy the backed-up switch configuration to the new switch.

```
copy tftp://hostip/filepath running-config
```

## Power supplies

The Z9332F-ON switch ships with two AC power supplies that support air-flow from the I/O to the PSU. From the PSU-side of the switch, PSU1 is on the right side; PSU2 is on the left side.

Two PSUs are required for full redundancy, but the switch can operate with a single PSU.

The PSUs are field replaceable. When running with full redundancy—two power supplies installed and running—you can remove and replace one PSU without disrupting traffic.

**CAUTION:** To prevent electrical shock, ensure that the Z9332F-ON switch is grounded properly. If you do not ground your equipment correctly, excessive emissions may result. Use a qualified electrician to ensure that the power cables meet your local electrical requirements.

**NOTE:** PSU airflow must match the airflow direction of the fans. The fans ship preinstalled with airflow from the I/O to the PSU. Optionally, you can order and install fans with airflow from the PSU to the I/O.

**NOTE:** Connect the power supply to the appropriate branch circuit protection as defined by your local electrical codes. Verify that the remote power source complies with the switch input power specifications.

**NOTE:** If you use a single PSU, install a blank plate in the other PSU slot. Use power supply 2 (PSU2) as the blank plate slot. To install the blank plate, use a #1 Philips screw driver.

**NOTE:** ESD damage can occur if components are mishandled. Always wear an ESD-preventive wrist or heel ground strap when handling the Z9332F-ON switch and components.

### Topics:

- [Components](#)
- [AC power supply installation](#)

## Components

**NOTE:** DC power is not supported.

**NOTE:** AC power requires HighLine 200–240 VAC support. Using 120 VAC does not provide adequate power for the system.

Power supply 1 (PSU1) is on the left side of the switch; power supply 2 (PSU2) is on the right side of the switch.



### 1. PSUs

The PSUs have an integrated fan, which you cannot replace individually; if the fan integrated in a PSU fails, you must replace the entire PSU. You can replace the fan trays individually. For fan tray replacement procedures, see [Fans](#).

**WARNING:** Prevent exposure and contact with hazardous voltages. Do not attempt to operate this switch with the safety cover removed.

**CAUTION:** Remove the power cable from the PSU before removing the PSU. Also, do not connect the power cable before you insert the PSU in the switch.

## PSU LEDs

- Solid green—Input is OK.
- Flashing yellow—There is a fault with the PSU.
- Flashing green blink at 1 Hz—Switch is in a standby/CR state.
- Off—PSU is off.

## AC power supply installation

**NOTE:** The PSU slides into the slot smoothly. Do not force a PSU into a slot as this action may damage the PSU or the switch.

**NOTE:** Ensure that you correctly install the PSU. When you install the PSU correctly, the power connector is on the left side of the PSU.

**NOTE:** If you use a single PSU, install a blank plate in the other PSU slot. If you are only using one power supply, install the power supply in the first slot, PSU1. Install a blank plate in the second slot, PSU2.

1. Remove the PSU slot cover from the Z9332F-ON switch using a small #1 Phillips screwdriver.
2. Remove the PSU from the electro-static bag.
3. Insert the PSU into the switch PSU slot—insert the exposed PSU connector first.

The PSU slot is keyed so that you can only fully insert the PSU in one orientation. When you install the PSU correctly, it snaps into place and is flushed with the back of the switch.

4. Plug in the appropriate AC 3-prongs cable from the switch PSU to the external power source.
5. Repeat steps 1–4 if you have a redundant PSU using the second PSU slot on the Z9332F-ON switch.

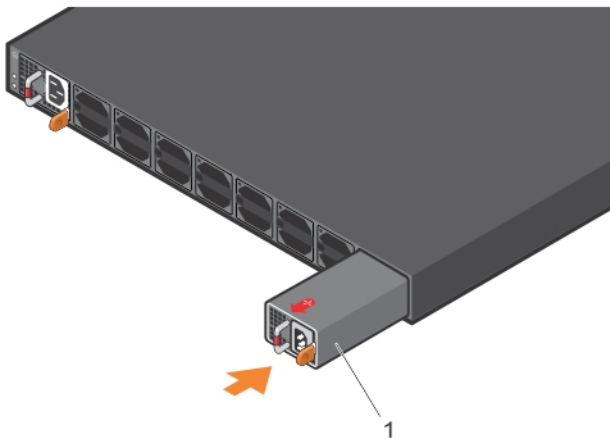

1. PSU

## AC power supply replacement

**CAUTION:** Disconnect the power cable before removing the power supplies. Also, disconnect all power cables before servicing.

**NOTE:** The PSU slides into the slot smoothly. Do not force a PSU into a slot as this action may damage the PSU or the Z9332F-ON switch.

**i** **NOTE:** If a PSU fails, you must replace the entire unit. There are no field serviceable components in the PSU. To request a hardware replacement, see <https://www.dell.com/support/>.

**i** **NOTE:** If you use a single PSU, install a blank plate in the other PSU slot. If you are only using one power supply, install the power supply in the first slot, PSU1. Install a blank plate in the second slot, PSU2.

1. Disconnect the power cable from the PSU.
2. Use the grab handle to slide the PSU out of the power supply bay.
3. Use the grab handle on the replacement PSU to slide it into the power supply bay.
4. Attach the power cables to the replacement PSU.

**i** **NOTE:** The switch powers up when the cables are connected between the power supply and the power source.

# Fans

The Z9332F-ON switch comes from the factory with two PSUs and seven fan modules that are installed in the switch. Fan module airflow is from the I/O to the PSU or from the PSU to the I/O. The fan modules and power supplies, which have integrated fans, are hot-swappable.

The fans ship preinstalled with airflow from the I/O to the PSU. From the PSU-side of the switch, fans are numbered from the right to the left. For example, FAN1 is on the right side of the switch; FAN7 is on the left side of the switch. Optionally, you can order and install fans with airflow from the PSU to the I/O.

- Fan airflow from the I/O to the PSU—normal airflow direction
- Fan airflow from the PSU to the I/O—reverse airflow direction

**CAUTION:** Switches with fan airflow from the PSU to the I/O—reverse airflow—are subject to tighter restrictions for power consumption on cables and optics that are used for 400 GbE ports. Reverse airflow switches do not support high-power cables or optics. 400 GbE transceivers and active cables may exceed the supported threshold.

**CAUTION:** Review the optics specification sheet to understand which models support airflow from the I/O to the PSU (normal) and which support airflow from the PSU to I/O (reverse).

**NOTE:** All fans and PSUs in a configuration must be in the same airflow direction.

Environmental factors can decrease the amount of time that is required between fan replacements. Check the environmental factors regularly. An increase in temperature and/or particulate matter in the air might affect performance—for example, new equipment installation).

## Topics:

- [Components](#)
- [Fan module installation](#)

## Components

The Z9332F-ON switch fans:

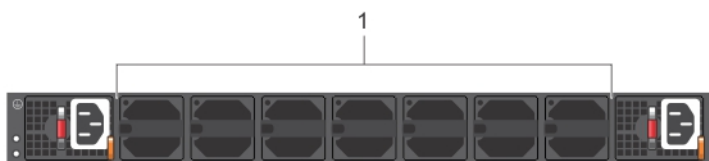

1. Fans

## Fan LEDs

- Solid green—Fan function is normal.
- Flashing yellow—There is a fan fault.
- Off—Fan is off.

# Fan module installation

The fan modules in the Z9332F-ON switch are field replaceable.

**CAUTION:** DO NOT mix airflow directions. All fans must use the same airflow direction—reverse or normal. If you mix the airflow direction, to avoid damage to the switch, you must correct the mixed airflow.

1. Take the fan module out of the shipping box.
2. Slide the module into the bay.

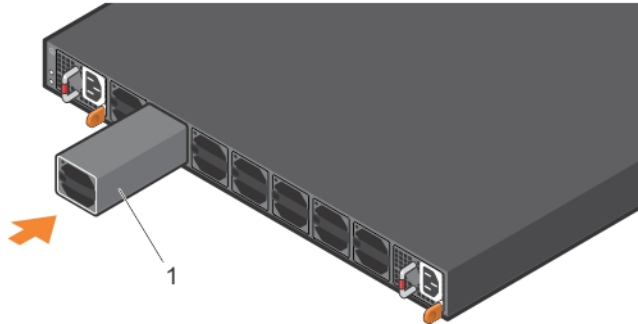

1. Fan module

# Fan module replacement

**CAUTION:** Complete the following steps within one minute or the switch temperature could rise above safe thresholds and the switch could shut down:

1. Take the replacement fan module out of the shipping box.
2. Slide the installed fan module out of the bay.
3. Slide the replacement module into the bay.

## Management ports

The Z9332F-ON switch provides three ports for management and one USB flash drive mount for file transfers.

**NOTE:** The output examples in this section are for reference only. Your output may vary.

### Topics:

- [RJ45 console port access](#)
- [USB storage mount](#)

## RJ45 console port access

The management ports are on the I/O-side of the switch.

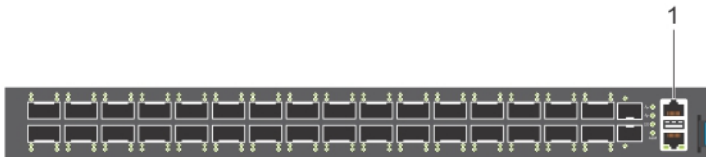

1. RJ45 console port (top); USB Type-A port (middle); RJ45 Ethernet port (bottom).

**NOTE:** Ensure that any equipment that is attached to the serial port can support the required 115200 baud rate.

**NOTE:** If the serial port on your computer cannot accept a female DB-9 connector, use a DB-9 to USB adapter.

1. Install the provided RJ45 connector-side of the provided cable into the switch console port.
2. Install the DB-9 female-side of the provided copper cable into the serial port on your computer.  
Or install the DB-9 cable into other data terminal equipment (DTE) server hardware.
3. Use the following settings to make the serial port connection:
  - 115200 baud rate
  - No parity
  - Eight data bits
  - One stop bit
  - No flow control

## USB storage mount

USB storage does not automatically mount. USB storage supports the FAT file system. To use USB storage, first mount the device using the following steps:

1. Start up the switch.
2. Press **Enter** on the **ONIE rescue mode** menu option from the ONIE Grub boot loader.
3. Create a mount directory for the USB storage.  
`ONIE:/ # mkdir /mnt/usb`
4. View the fixed disks using the `fdisk` command.

```
ONIE:/mnt # fdisk -l
```

#### For internal storage:

```
Disk /dev/sda: 15.8 GB, 15829303296 bytes
255 heads, 63 sectors/track, 1924 cylinders
Units = cylinders of 16065 * 512 = 8225280 bytes
```

Device	Boot	Start	End	Blocks	Id	System
/dev/sda1		1	1925	15458303+	ee	EFI GPT

#### For USB storage:

```
Disk /dev/sdb: 30.9 GB, 30942946304 bytes
64 heads, 32 sectors/track, 29509 cylinders
Units = cylinders of 2048 * 512 = 1048576 bytes
```

Device	Boot	Start	End	Blocks	Id	System
--------	------	-------	-----	--------	----	--------

5. Mount the device /dev/sdb to the /mnt/usb directory.

```
ONIE:/ # mount -t vfat /dev/sdb /mnt/usb
```

**i** **NOTE:** If the /mnt/usb directory is missing, the following message displays: mount: mounting /dev/sdb on /mnt/usb failed: No such file or directory.

**i** **NOTE:** If the USB device is not seen, the following message displays: mount: mounting /dev/sdb on /mnt/usb failed: No such device or address.

## Before you install an operating system

**NOTE:** Before you install an operating system, ensure that the switch has the most current ONIE and firmware version. To upgrade your switch, go the *Drivers and Downloads* page for your switch as [www.dell.com/support](http://www.dell.com/support).

After powering on the Z9332F-ON switch, it goes through a power-on self-test (POST). POST runs every time that the switch is initialized and checks the hardware components to determine if the switch is fully operational before booting. After POST, the switch uses the Grub bootloader.

To select an entry, use the up and down arrow keys. Press **Enter** to select an operating system or enter `e` to edit the commands before booting. Enter `c` for a command line. The selected entry runs automatically in the operating system.

### Grub bootloader example

```
GNU GRUB  version 2.02~beta2+e4a1fe391

+-----+
|*ONIE:  Install OS      |
| ONIE:  Rescue         |
| ONIE:  Uninstall OS   |
| ONIE:  Update ONIE    |
| ONIE:  Embed ONIE     |
| EDA-DIAG              |
|                       |
+-----+
```

Your switch comes with ONIE installed.

**NOTE:** To access ONIE, use the RJ45 or USB console port.

### ONIE example

```
ONIE: Install OS
  For downloading and installing an OS from a URL
  Starts ONIE with ONIE Discovery Service
  (factory default boot)
ONIE: Rescue
  Starts ONIE without ONIE Discovery Service
  Useful for running Diagnostics manually
ONIE: Uninstall OS
  Restore to factory defaults erases any installed OS
ONIE: Update ONIE
  For downloading and updating ONIE from a URL
ONIE: Embed ONIE
  For downloading and updating ONIE from a URL and erases any installed OS
```

During the initial setup, the switch boots to ONIE Install. ONIE Install boots with ONIE Discovery to the console, `ONIE: .`

**NOTE:** For more information, see the *Open Networking Hardware Diagnostic Guide* at [www.dell.com/support](http://www.dell.com/support).

**NOTE:** After you have securely installed and powered on the Z9332F-ON switch, to configure your switch, see your third-party ONIE-compatible operating system or the Dell EMC operating system documentation.

#### Topics:

- [Check your switch](#)

- ONIE service discovery

## Check your switch

To confirm that ONIE is working properly, use the `onie-sysinfo` command. Run the `onie-sysinfo` command at the ONIE prompt.

```
ONIE:/ # onie-sysinfo x86_64-dell_<platform>_c25

ONIE:/ # onie-sysinfo -c (Machine arch)
x86_64
ONIE:/ # onie-sysinfo -v (ONIE Version programmed)
x.xx.x.x
ONIE:/ #
ONIE:/ # uname -a
Linux onie x.x.xx-onie+ #1 SMP Tue Dec 9 17:08:16 PST 2014 x86_64 GNU/Linux
ONIE:/ #
```

## ONIE service discovery

ONIE attempts to locate the installer through several discovery methods.

To download and run an installer, the ONIE Service Discovery feature follows these steps in order and uses the first successful method found:

1. Search locally attached storage devices for one of the ONIE default installer filenames—for example, `onie self update` from the USB.
2. Discover TFTP-based image from the DHCP server.
3. Query to the IPv6 link-local neighbors using HTTP for an installer.

If none of the ONIE Service Discovery methods are successful, you can disable this using the `onie-discovery-stop` command.

You can install an operating system manually from HTTP, FTP, TFTP, or USB using the `onie-nos-install <URL>` command.

 **NOTE:** If you have a recovery USB plugged into your switch, you must remove it before using the `onie-nos-install` command.

The ONIE Install environment uses DHCP to assign an IP address to the management interface—`eth0`. If that fails, it uses the default IP address `192.168.3.10/255.255.255.0`.

To display the IP address, use the `ifconfig eth0` command, as shown.

```
ONIE:/ # ifconfig eth0
eth0 Link encap:Ethernet HWaddr 90:B1:1C:F4:9C:76
  inet addr:xx.xx.xx.xx Bcast:xx.xxx.xxx.xxx Mask:xxx.x.x.x
  inet6 addr: fe80::92b1:1cff:fef4:9c76/64 Scope:Link
UP BROADCAST RUNNING MULTICAST MTU:1500 Metric:1
RX packets:18 errors:0 dropped:0 overruns:0 frame:0
TX packets:24 errors:0 dropped:0 overruns:0 carrier:0 collisions:0 txqueuelen:1000
RX bytes:1152 (1.1 KiB) TX bytes:6864 (6.7 KiB)
Interrupt:21 Memory:ff300000-ff320000
```

To assign an IP address to the management interface, `eth0`, and verify network connectivity, use the `ifconfig eth0 <ip address>` command, as shown.

```
ONIE:/ # ifconfig eth0 xx.xx.xx.xx/xx up

Verify the network connection with ping.
ONIE:/ # ping xx.xx.x.xx
PING xx.xx.x.xx (xx.xx.x.xx): 56 data bytes
64 bytes from xx.xx.x.xx: seq=0 ttl=62 time=1.357 ms
64 bytes from xx.xx.x.xx: seq=1 ttl=62 time=0.577 ms
^C
```

# Specifications

This section lists the Z9332F-ON switch specifications.

**CAUTION:** Operate the product at an ambient temperature not higher than 45°C (113°F).

**NOTE:** For RoHS information, see [Restricted Material Compliance](#).

## Topics:

- Chassis physical design
- IEEE standards
- Agency compliance
- USA Federal Communications Commission statement
- European Union EMC directive conformance statement
- India
- Japan VCCI compliance for class A equipment
- Korean certification of compliance
- Safety standards and compliance agency certifications
- Electromagnetic compatibility
- Product recycling and disposal

## Chassis physical design

**Table 5. Chassis physical design**

Parameter	Specifications
Height	1.70 inches (43.1 mm)
Width	17.26 inches (438.5 mm)
Depth	25.88 inches (657.5 mm)
Chassis weight with factory-installed components	31 lbs (14.1 kg)—PSUs and fans
Rack clearance required	Front: 5 inches (12.7 cm) Back: 5 inches (12.7 cm)

**Table 6. Environmental parameters**

Parameter	Specifications
Operating temperature	0° to 45°C (32°F to 113°F) continuously <b>NOTE:</b> Reduce maximum temperature by 1°C/125 meters (1°F/228 feet) above 950 meters (3,117 feet).
Operating humidity	5% to 90% (RH), non-condensing
Storage temperature	–40° to 70°C (–40° to 158°F )
Storage humidity	5% to 90%, non-condensing
Maximum thermal output	635W = 2167 BTU/Hr

**Table 6. Environmental parameters (continued)**

Parameter	Specifications
Maximum operational altitude	10,000 feet (3,048 meters)
Maximum non-operational altitude	35,000 feet (10,668 meters)
Shock	Dell EMC Spec SV0115

 **NOTE:** AC power requires HighLine 200–240 VAC support. Using 120 VAC does not provide adequate power for the system.

**Table 7. AC power requirements**

Parameter	Specifications
Power supply	200–240 VAC 50/60 Hz
Maximum current draw per system	8.5A@200VAC
Maximum power consumption	1244.86 W maximum
Typical power consumption	1004 W typical—Measured @ 45°C, 16 ports with AOC and 16 ports with SR8 optics running snake traffic

## IEEE standards

The Z9332F-ON switch complies with the following IEEE standards.

- 802.1ab (LLDP)
- 802.1ax (Layer 2)
- 802.1d, 802.1w, 802.1s, 802.1x (Mgmt/Security), 802.3x (Layer 2)
- 802.3 (1000BASE-KX)
- 802.3ba (40GbE and 100GbE ports)

## Agency compliance

The Z9332F-ON switch is designed to comply with the following safety and agency requirements:

## USA Federal Communications Commission statement

This equipment has been tested and found to comply with the limits for a Class A digital device, pursuant to Part 15 of the FCC rules. These limits are designated to provide reasonable protection against harmful interference when the equipment is operated in a commercial environment. This equipment generates, uses, and can radiate radio frequency energy. If it is not installed and used in accordance to the instructions, it may cause harmful interference to radio communications. Operation of this equipment in a residential area is likely to cause harmful interference, in which case users will be required to take whatever measures necessary to correct the interference at their own expense.

Properly shielded and grounded cables and connectors must be used in order to meet FCC emission limits. Dell EMC is not responsible for any radio or television interference caused by using other than recommended cables and connectors or by unauthorized changes or modifications in the equipment. Unauthorized changes or modification could void the user's authority to operate the equipment.

This device complies with Part 15 of the FCC Rules. Operation is subject to the following two conditions: (1) this device may not cause harmful interference, and (2) this device must accept any interference received, including interference that may cause undesired operation.

### Industry Canada Class A emission compliance statement

This Class A digital apparatus complies with Canadian ICES-003.

### Avis de conformité à la réglementation d'Industrie Canada

Cet appareil numérique de la classe A est conforme à la norme NMB-003 du Canada.

Figure 2. Canadian Department of Communication Statement

## European Union EMC directive conformance statement

This product is in conformity with the protection requirements of EU Council Directive 2004/108/EC on the approximation of the laws of the Member States relating to electromagnetic compatibility. Dell EMC cannot accept responsibility for any failure to satisfy the protection requirements resulting from a non-recommended modification of this product, including the fitting of non-Dell EMC option cards.

This product has been tested and found to comply with the limits for Class A Information Technology Equipment according to CISPR 32/CISPR34 and EN55032 / EN55034. The limits for Class A equipment were derived for commercial and industrial environments to provide reasonable protection against interference with licensed communication equipment.

**i** **NOTE:** This is a Class A product. In a domestic environment, this device may cause radio interference, in which case, you may be required to take adequate measures.

European Community Contact

Dell EMC, EMEA - Central

Dahlienweg 19

66265 Heusweiler

Germany

Tel: +49 172 6802630

Email: EMEA Central Sales

## India

This product conforms to the relevant Essential Requirements of TEC, Department of Telecommunications, Ministry of Communications, Govt of India, New Delhi-110001.

## Japan VCCI compliance for class A equipment

**Class A information statement** for VCCI 32 -1:2016

この装置は、クラスA機器です。この装置を住宅環境で使用すると電波妨害を引き起こすことがあります。この場合には使用者が適切な対策を講ずるよう要求されることがあります。

VCCI - A

This is Class A product based on the standard of the Voluntary Control Council For Interference by Information Technology Equipment (VCCI). If this equipment is used in a domestic environment, radio disturbance may arise. When such trouble occurs, the user may be required to take corrective actions.

**i** **NOTE:** Use the AC power cords with Dell EMC equipment only. Do not use Dell EMC AC power cords with any unauthorized hardware.

本製品に同梱いたしております電源コードセットは、本製品専用です。本電源コードセットは、本製品以外の製品ならびに他の用途でご使用いただくことは出来ません。製品本体には同梱された電源コードセットを使用し、他製品の電源コードセットを使用しないで下さい。

## Korean certification of compliance

### Korean certification of compliance

A급 기기 (업무용 방송통신기자재)	이 기기는 업무용(A급) 전자파적합기기로서 판매자 또는 사용자는 이 점을 주의하시기 바라며, 가정외의 지역에서 사용하는 것을 목적으로 합니다.
------------------------	---

### Korean package label

	 [equipment type]
품명(Product Name)	Ethernet Switch
모델명(Model)	[model number]
신청인(Applicant)	Dell Technologies
제조사(Manufacturer)	[Manufacturer]
제조년월(Manufacturing Date)	[date]
제조국(Country of Origin)	China

## Safety standards and compliance agency certifications

- CUS UL 60950-1, 2nd Edition
  - Meets or exceeds Hi Pot and Ground Continuity testing per UL 60950-1.
- CSA 60950-1-03, 2nd Edition
- EN 60950-1, 2nd Edition
- EN 60825-1, 1st Edition
- EN 60825-1 Safety of Laser Products—Part 1: Equipment Classification Requirements and User's Guide
- EN 60825-2 Safety of Laser Products—Part 2: Safety of Optical Fibre Communication Systems
- FDA Regulation 21CFR 1040.10 and 1040.11
- IEC 60950-1, 2nd Ed, including all National Deviations and Group Differences
- IEC 62368-1

# Electromagnetic compatibility

## Emissions

- International: CISPR32: Class A
- Australia/New Zealand: AS/NZS CISPR 32: Class A
- Canada: ICES-003, Issue-4, Class A
- Europe: EN55032: CISPR 32: Class A
- International: CISPR 32: Class A
- EN55032
- Japan: VCCI V-3/2011.04, Class A
- Korea: KN32, Class A
- Taiwan: CNS13438, Class A
- USA: FCC CFR47 Part 15, Subpart B, Class A

## Immunity

- EN 300 386 v2.1.1 (2016-07) EMC for Network Equipment
- EN 55024 + A1 + A2
- EN 61000-3-2 Harmonic Current Emissions
- EN 61000-3-3 Voltage Fluctuations and Flicker
- EN 61000-4-2 ESD
- EN 61000-4-3 Radiated Immunity
- EN 61000-4-4 EFT
- EN 61000-4-5 Surge
- EN 61000-4-6 Low Frequency Conducted Immunity
- EN 61000-6-1
- EN 61000-4-11 Voltage Dips/Interruptions

## Product recycling and disposal

You must recycle or discard this switch according to applicable local and national regulations. Dell EMC encourages owners of information technology (IT) equipment to responsibly recycle their equipment when it is no longer needed. Dell EMC offers a variety of product return programs and services in several countries to assist equipment owners in recycling their IT products.

## Waste electrical and electronic equipment (WEEE) directive for recovery, recycle and reuse of IT and telecommunications products

Dell EMC switches are labeled in accordance with European Directive 2002/96/EC concerning waste electrical and electronic equipment (WEEE). The Directive determines the framework for the return and recycling of used appliances as applicable throughout the European Union. This label is applied to various products to indicate that the product is not to be thrown away, but rather reclaimed upon end of life per this Directive.



**Figure 3. The European WEEE symbol**

In accordance with the European WEEE Directive, electrical and electronic equipment (EEE) is to be collected separately and to be reused, recycled, or recovered at end of life. Users of EEE with the WEEE marking per Annex IV of the WEEE Directive, as shown above, must not dispose of end of life EEE as unsorted municipal waste, but use the collection framework available to customers for the return, recycling and recovery of WEEE. Customer participation is important to minimize any potential effects of EEE on the environment and human health due to the potential presence of hazardous substances in EEE.

Dell EMC products, which fall within the scope of the WEEE, are labeled with the crossed-out wheelie-bin symbol, as shown above, as required by WEEE.

For information on Dell EMC product recycling offerings, see the WEEE Recycling instructions on Support. For more information, contact the Dell EMC Technical Assistance Center.

## Dell EMC support

The Dell EMC support site provides documents and tools to help you effectively use Dell EMC equipment and mitigate network outages. Through the support site you can obtain technical information, access software upgrades and patches, download available management software, and manage your open cases. The Dell EMC support site provides integrated, secure access to these services.

To access the Dell EMC support site, go to [www.dell.com/support/](http://www.dell.com/support/). To display information in your language, scroll down to the bottom of the web page and select your country from the drop-down menu.

- To obtain product-specific information, enter the 7-character Service Tag or 11-digit express service code of your switch, which is found on the pull-out tag, also known as a luggage tag, and click **Submit**.
- To receive more technical support, click **Contact Us**. On the Contact Information web page, click **Technical Support**.

To access product documentation and resources that might be helpful to install, configure, and troubleshoot the specific Dell EMC Networking switch, see the [Dell EMC Networking OS10 Info Hub](#).

To search for drivers and downloads, go to [www.dell.com/drivers/](http://www.dell.com/drivers/).

To participate in Dell EMC community blogs and forums, go to [www.dell.com/community](http://www.dell.com/community).