

Dell PowerSwitch S5148F-ON

Set-up Guide

Notes, cautions, and warnings

 **NOTE:** A NOTE indicates important information that helps you make better use of your product.

 **CAUTION:** A CAUTION indicates either potential damage to hardware or loss of data and tells you how to avoid the problem.

 **WARNING:** A WARNING indicates a potential for property damage, personal injury, or death.

Chapter 1: About this guide	4
Related documents.....	4
Information Symbols.....	4
Chapter 2: Site preparations	6
Site selection.....	6
Cabinet placement.....	6
Rack mounting.....	7
Switch ground.....	7
Fans and airflow.....	7
Power.....	7
Storing components.....	7
Chapter 3: S5148F-ON switch Installation	8
Unpack.....	8
Rack or cabinet installation.....	9
ReadyRails installation.....	9
1U Tool-less mount installation.....	10
Two-post flush-mount installation.....	11
Two-post center-mount installation.....	12
Four-post threaded installation.....	13
S5148F-ON installation.....	14
1U front-rack installation.....	14
Optics installation.....	16
Optics removal.....	16
Switch power-up.....	16
After switch installation.....	17
Chapter 4: Specifications	18
Chassis physical design.....	18
Chapter 5: Support	20

About this guide

This guide provides site preparation recommendations, step-by-step procedures for rack mounting and desk mounting, inserting modules, and connecting to a power source.

CAUTION: To avoid electrostatic discharge (ESD) damage, wear grounding wrist straps when handling this equipment.

NOTE: Only trained and qualified personnel can install this equipment. Read this guide before you install and power up this equipment. This equipment contains two power cords. Disconnect both power cords before servicing.

NOTE: This equipment contains optical transceivers, which comply with the limits of Class 1 laser radiation.



Figure 1. Class 1 laser product tag

NOTE: When no cable is connected, visible and invisible laser radiation may be emitted from the aperture of the optical transceiver ports. Avoid exposure to laser radiation and do not stare into open apertures.

Topics:

- [Related documents](#)
- [Information Symbols](#)

Related documents

For more information about the S5148F-ON switch, see the following documents.

- *OS10 Enterprise Edition Release Notes*
- *OS10 Enterprise Edition User Guide*
- *Installation Guide for the S5148F-ON Switch*
- *Open Networking Hardware Diagnostic Guide*
- *Dell S5148F-ON Switch Release Notes*

NOTE: For the most recent documentation, see <https://www.dell.com/support>.

Information Symbols

This book uses the following information symbols:

NOTE: The Note icon signals important operational information.

CAUTION: The Caution icon signals information about situations that could result in equipment damage or loss of data.

NOTE: The Warning icon signals information about hardware handling that could result in injury.

 **NOTE:** The ESD Warning icon requires that you take electrostatic precautions when handling the device.

Site preparations

The S5148F-ON switch is suitable for installation as part of a common bond network (CBN).

You can install the switch in:

- Network telecommunication facilities
- Data centers
- Other locations where the National Electric Code (NEC) applies.

For more information about the S5148F-ON switch specifications, see [Specifications](#).

i **NOTE:** Install the switch into a rack or cabinet before installing any optional components.

Topics:

- [Site selection](#)
- [Cabinet placement](#)
- [Rack mounting](#)
- [Switch ground](#)
- [Fans and airflow](#)
- [Power](#)
- [Storing components](#)

Site selection

Install your equipment in restricted access areas. A restricted access area is one where service personnel can only gain access using a special tool, lock, key, or other means of security. The authority responsible for the location controls access to the restricted area.

Ensure that the area where you install your switch meets the following safety requirements:

- Near an adequate power source. Connect the switch to the appropriate branch circuit protection according to your local electrical codes.
- Environmental—switch location—continuous temperature range is from 0°C to 45°C (32°F to 113°F).
- Operating humidity is from 5 to 85 percent non-condensing, continuous.
- In a dry, clean, well-ventilated, and temperature-controlled room, away from heat sources such as hot cooling vents or direct sunlight.
- Away from sources of severe electromagnetic noise.
- Positioned in a rack or cabinet, or on a desktop with adequate space in the front, back, and sides for proper ventilation and access.
- Install the switch in Information Technology Rooms in accordance with Article 645 of the National Electrical Code and NFPA 75.

For more information about switch storage and environmental temperatures, see [Specifications](#).

Cabinet placement

Install the S5148F-ON switch only in indoor cabinets designed for use in a controlled environment.

Do not install the switch in outside cabinets. For cabinet placement requirements, see [Site selections](#).

The cabinet must meet minimum size requirements. Airflow must be in accordance with the Electronic Industries Alliance (EIA) standard. Ensure that there is a minimum of 5 inches (12.7 cm) between the intake and exhaust vents and the cabinet wall.

Rack mounting

When you prepare your equipment rack, ensure that the rack is grounded. Ground the equipment rack to the same ground point the power service in your area uses. The ground path must be permanent.

Switch ground

Dell Technologies recommends grounding your switch. Use the S5148F-ON switch in a CBN.

Fans and airflow

Fan installation is done as part of the factory install based on stock keeping unit (SKU) type. The S5148F-ON switch has SKUs that support the following configurations:

- AC PSU with fan airflow from the I/O to the PSU—normal
- AC PSU with fan airflow from the PSU to the I/O—reverse
- DC fan unit with airflow from the I/O to the PSU—normal
- DC fan unit with fan airflow from the PSU to the I/O—reverse

Be sure to order the fans suitable to support your site's ventilation. Use a single type of airflow fan in your switch. Do not mix reverse and normal airflows in a single switch.

For proper ventilation, position the switch in an equipment rack or cabinet with a minimum of 5 inches (12.7 cm) of clearance around the exhaust vents. The fan speed varies based on internal temperature monitoring. The switch never intentionally turns off the fans.

Power

To connect the switch to the applicable power source, use the appropriate power cable. An AC power cable is included with the switch.

When installing AC or DC switches, follow the requirements of the National Electrical Code ANSI/NFPA 70, where applicable.

The switch is powered-up when the power cable is connected between the switch and the power source.

CAUTION: Always disconnect the power cable before you service the power supply slots. The switch has multiple power cords. Before servicing, ensure all power cords are disconnected.

CAUTION: On the AC switch, use the power supply cable as the main disconnect device. Ensure that the socket-outlet is located/installed near the equipment and is easily accessible.

NOTE: Module power is software controlled. You do not see module LEDs when the switch powers up in ONIE.

Storing components

If you do not install your S5148F-ON switch and components immediately, properly store the switch and all optional components following these guidelines:

- Storage location temperature must remain constant. The storage range is from -40° to 70°C (-40° to 158°F).
- Store on a dry surface or floor, away from direct sunlight, heat, and air conditioning ducts.
- Store in a dust-free environment.

NOTE: ESD damage can occur when components are mishandled. Always wear an ESD-preventive wrist or heel ground strap when handling the switch and its accessories. After you remove the original packaging, place the S5148F-ON switch and its components on an anti-static surface.

S5148F-ON switch Installation

To install the S5148F-ON switch, complete the installation procedures in the order presented in this section.

Always handle the switch and its components with care. Avoid dropping the switch or any field replaceable units (FRUs).

i **NOTE:** ESD damage can occur if components are mishandled. Always wear an ESD-preventive wrist or heel ground strap when handling the switch and its components. As with all electrical devices of this type, take all the necessary safety precautions to prevent injury when installing this switch.

Topics:

- [Unpack](#)
- [Rack or cabinet installation](#)
- [ReadyRails installation](#)
- [1U Tool-less mount installation](#)
- [Two-post flush-mount installation](#)
- [Two-post center-mount installation](#)
- [Four-post threaded installation](#)
- [S5148F-ON installation](#)
- [Optics installation](#)
- [Switch power-up](#)
- [After switch installation](#)

Unpack

i **NOTE:** Before unpacking the switch, inspect the container and immediately report any evidence of damage.

When unpacking the S5148F-ON switch, make sure that the following items are included:

- One S5148F-ON switch
 - One RJ-45 to DB-9 female cable
 - Two sets of rail kits, no tools required
 - Two PSUs
 - Four fan units
 - Two country- and region-specific AC power cords
 - *S5148F-ON Set-up Guide*
 - *Safety and Regulatory Information*
 - *Warranty and Support Information*
1. Place the container on a clean, flat surface and cut all straps securing the container.
 2. Open the container or remove the container top.
 3. Carefully remove the switch from the container and place it on a secure and clean surface.
 4. Remove all packing material.
 5. Inspect the product and accessories for damage.

Rack or cabinet installation

You may either place the switch on a rack shelf or mount the switch directly into a 19" wide, EIA-310- E-compliant rack. Rack mounting includes four-post, two-post, round threaded holes, or square holes. The ReadyRails system is provided for 1U front-rack and two-post installations.

The ReadyRails system includes two separately packaged rail assemblies. To begin installation, separate each rail assembly by sliding the inside rail out of the outside rail.

 **WARNING:** This guide is a condensed reference. Read the safety instructions in your *Safety, Environmental, and Regulatory* information booklet before you begin.

 **NOTE:** The illustrations in this section are not intended to represent a specific switch.

 **NOTE:** Do not use the mounted ReadyRails as a shelf or a workplace.

Rack mount safety considerations

- Rack loading—Overloading or uneven loading of racks may result in shelf or rack failure, possibly damaging the equipment and causing personal injury. Stabilize racks in a permanent location before loading begins. Mount the components starting at the bottom of the rack, then work to the top. Do not exceed your rack's load rating.
- Power considerations—Connect only to the power source specified on the unit. When you install multiple electrical components in a rack, ensure that the total component power ratings do not exceed the circuit capabilities. Overloaded power sources and extension cords present fire and shock hazards.
- Elevated ambient temperature—If you install the switch in a closed rack assembly, the operating temperature of the rack environment may be greater than the room ambient temperature. Use care not to exceed the 45°C maximum ambient temperature of the switch.
- Reduced air flow—Do not compromise the amount of airflow required for safe operation of the equipment. Install the equipment in the rack so that the equipment constantly has the correct amount of airflow surrounding it.
- Reliable earthing—Maintain reliable earthing of rack-mounted equipment. Pay particular attention to the supply connections other than the direct connections to the branch circuit, for example: use of power strips.
- Do not mount the equipment with the fan panel facing in the downward position.

ReadyRails installation

To easily configure your rack for switch installation, use the ReadyRails rack mounting system provided.

You can install the ReadyRails system using the 1U tool-less square-hole method or one of three possible 1U threaded round-hole methods. The tooled installation methods include two-post flush mount, two-post center mount, or four-post threaded mount.

To begin installation, separate each rail assembly by sliding the inside rail out of the outside rail.

 **NOTE:** For more installation instructions, see the installation labels attached to the rail assembly.

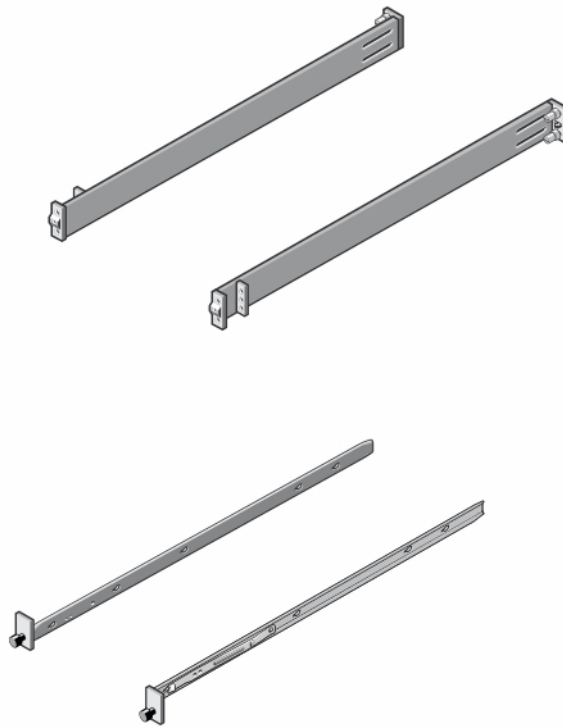

Figure 2. Separate rails

1U Tool-less mount installation

NOTE: For more installation instructions, see the installation labels attached to the rail assembly.

1. Face the ReadyRails flange ears facing outward. Place one rail between the left and right vertical posts. Align and seat the back flange rail pegs in the back vertical post flange.
The center extractions show how the pegs appear in both the square and nonthreaded round holes.

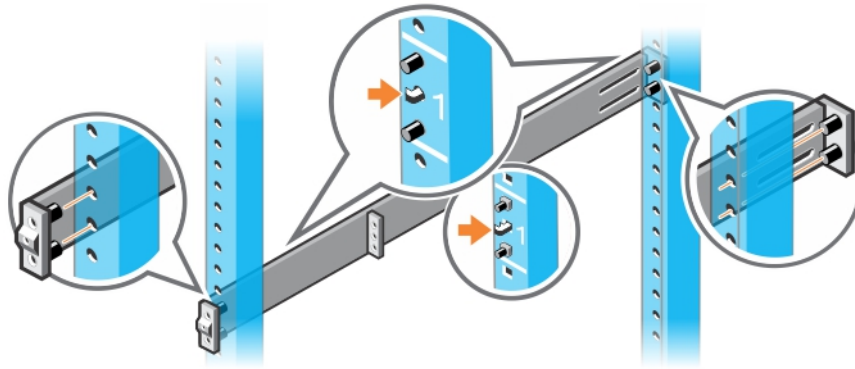

Figure 3. 1U tool-less installation

2. Align and seat the front flange pegs in the holes on the front side of the vertical post.

i **NOTE:** Be sure that the rails click into place and are secure.

3. Repeat this procedure for the second rail.
4. To remove each rail, pull on the latch release button on each flange ear and unseat each rail.

Two-post flush-mount installation

i **NOTE:** For more installation instructions, see the installation labels attached to the rail assembly.

1. For this configuration, remove the latch castings from the front side of each ReadyRails assembly, item 1.
To remove the two screws from each front flange ear on the switch side of the rail and remove each latch casting, use a Torx screwdriver. Retain the latch castings for future rack requirements. It is not necessary to remove the back flange castings.

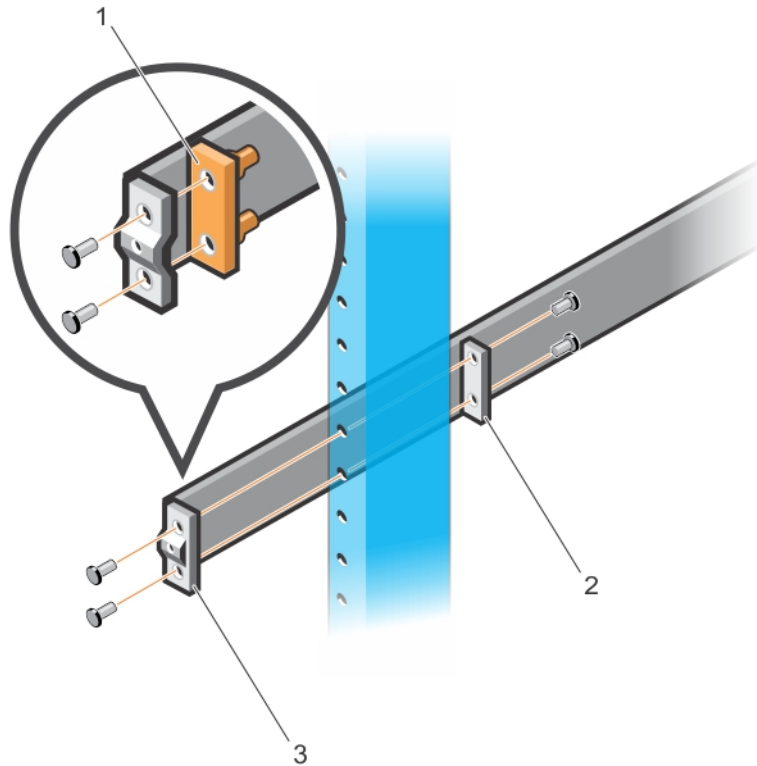

Figure 4. Two-post flush-mount installation

2. Attach one rail to the front post flange with two user-supplied screws, item 2.
3. Slide the plunger bracket forward against the vertical post and secure the plunger bracket to the post flange with two user-supplied screws, item 3.
4. Repeat this procedure for the second rail.

Two-post center-mount installation

NOTE: For more installation instructions, see the installation labels attached to the rail assembly.

1. Slide the plunger bracket rearward until it clicks into place and secure the bracket to the front post flange with two user-supplied screws, item 1.

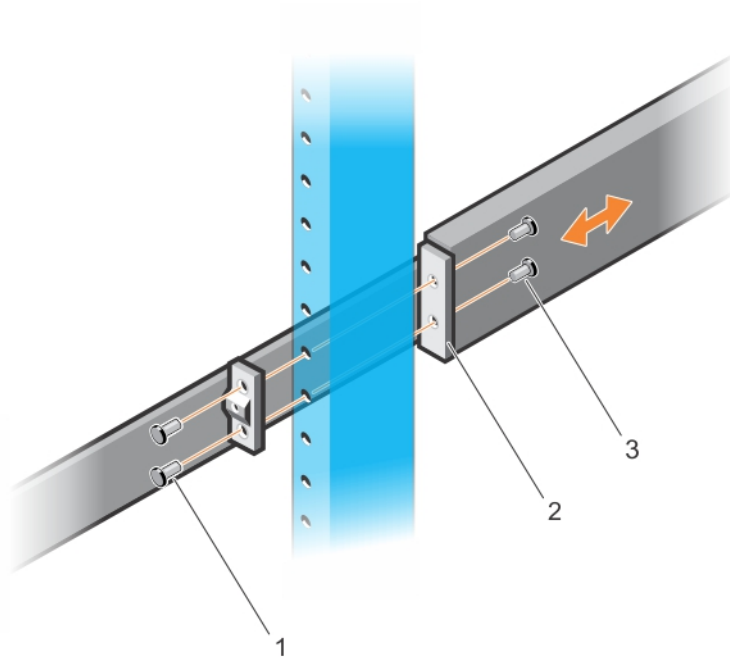

Figure 5. Two-post center-mount installation

2. Slide the back bracket towards the post. Secure it to the post flange with two user-supplied screws, items 2 and 3.
3. Repeat this procedure for the second rail.

Four-post threaded installation

NOTE: For more installation instructions, see the installation labels attached to the rail assembly.

1. Remove the latch castings from each end of the ReadyRails assemblies. To remove the two screws each latch casting, use a Torx driver.
Retain the latch castings for future rack requirements.

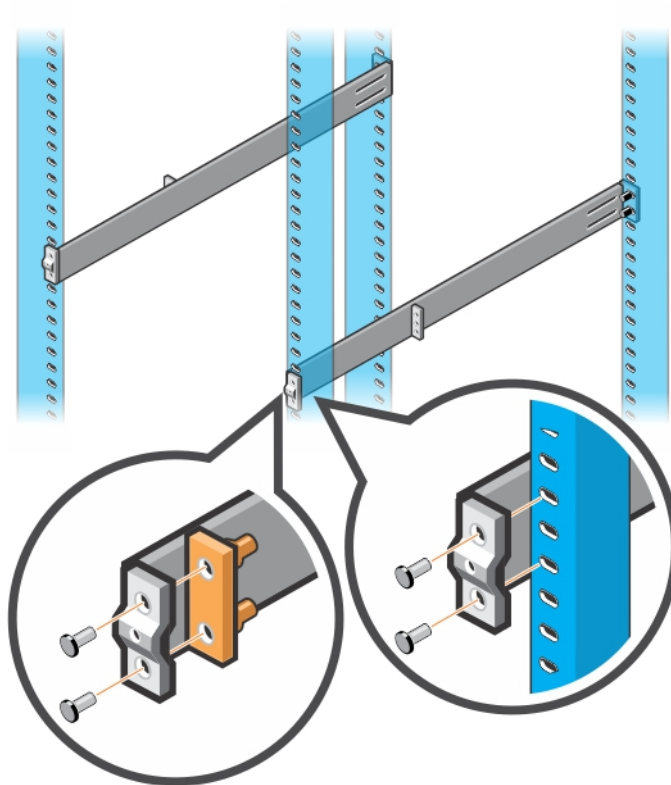

Figure 6. Four-post threaded installation

2. For each rail, attach the front and back flanges to the post flanges with two user-supplied screws at each end.

S5148F-ON installation

For the 1U two-post configurations, slide the switch into the rails in the same manner as the four-post configurations.

1U front-rack installation

Configure the rails that are attached to the switch.

1. **NOTE:** For more information, see the installation instruction labels on the rail.

Attach the inner switch rails to the S5148F-ON switch.

Line up the rail with the mounting heads and attach the rail to the chassis. Slide the rail back until it locks into place. The following shows the detail of the front standoff with the locking tab:

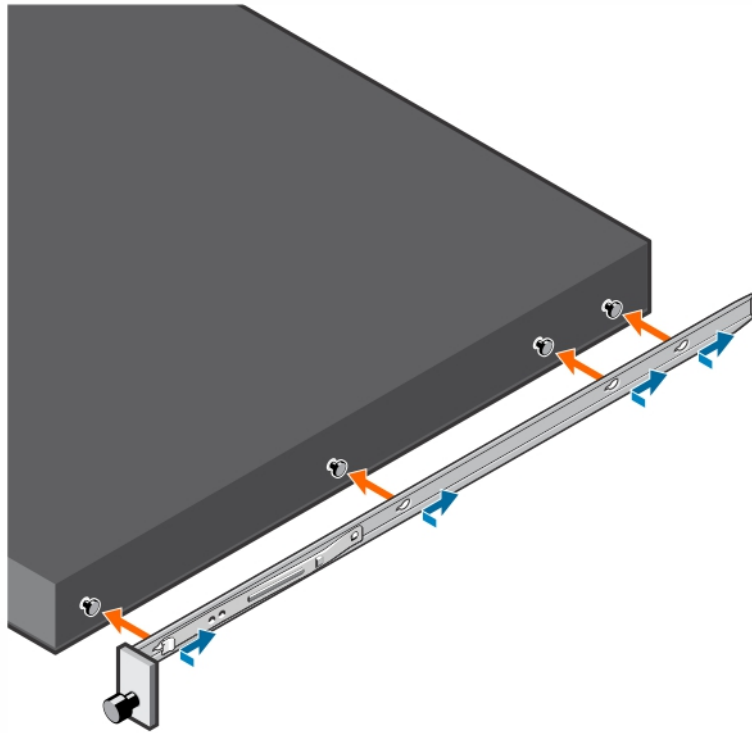

Figure 7. Switch rail attachment

2. After you install both rails, line them up on the ReadyRails. Slide the switch in until it is flush with the front of rack. About three inches before you fully insert your switch, the rail locking feature engages to keep the switch from inadvertently sliding out and falling.

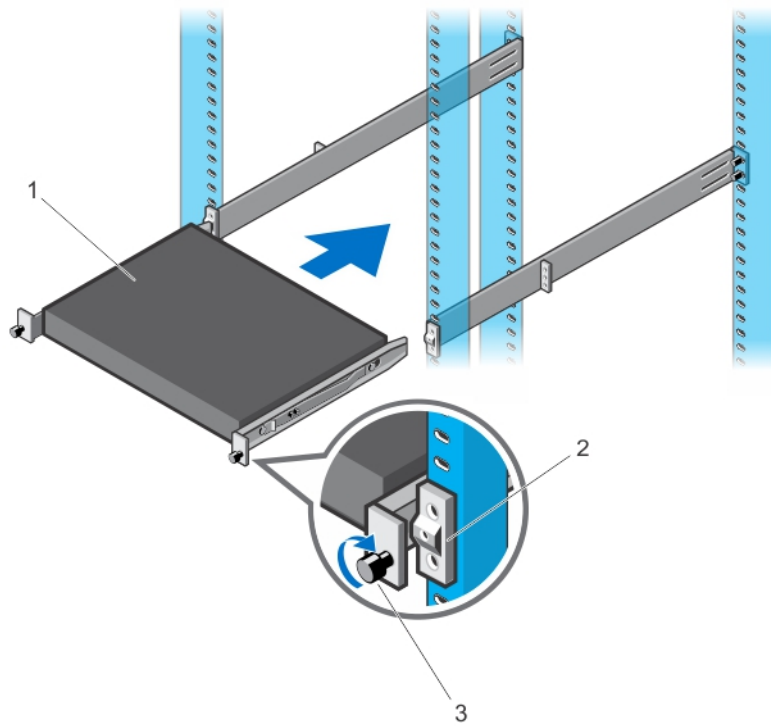



Figure 8. Front rack installation

 **NOTE:** Do not use the mounted Ready-Rails as a shelf or a workplace.

3. Tighten the two thumb screws and rack screws.

To remove the chassis from the rack or cabinet, press in the two side-release bars on the chassis at the same time and slide the chassis forward.

Optics installation

 **WARNING:** When working with optical fibers, follow all warning labels and always wear eye protection. Never look directly into the end of a terminated or unterminated fiber or connector as it may cause eye damage.

1. Position the optic so it is in the correct position.

The optic has a key that prevents it from being inserted incorrectly.

2. Insert the optic into the port until it gently snaps into place.

 **NOTE:** When you cable the ports, be sure not to interfere with the airflow from the small vent holes above and below the ports.

Optics removal

Remove an optic by pushing the tab on the optic and sliding the optic from the port.

When removing optics with direct attach cables (DACs) from the port, pull the release tab firmly and steadily. Before pulling the release tab, you may need to gently push the optic into the port to ensure that it is seated properly. Do not jerk or tug repeatedly on the tab.

Switch power-up

Supply power to the S5148F-ON switch after you mount it in a rack or cabinet.

Reinspect your switch before power up. Verify the following:

- The equipment is properly secured to the rack. Dell Technologies recommends properly grounding the switch.
- The ambient temperature around the unit, which may be higher than the room temperature, is within the limits specified for the S5148F-ON switch, see [Specifications](#).
- There is sufficient airflow around the unit.
- The input circuits are correctly sized for the loads and that you use sufficient overcurrent protection devices.
- All protective covers are in place.
- Blank panels are installed if you do not install optional modules.

 **CAUTION:** Do not power up the switch if you did not install a fan module.

 **NOTE:** A US AC power cable is included for powering up an AC power supply. You must order all other power cables separately.

 **NOTE:** ESD damage can occur if components are mishandled. Always wear an ESD-preventive wrist or heel ground strap when handling the switch and its components.

Power up sequence

When the switch powers up, the fans immediately come on at high speed. The fan speed slows as the switch continues to boot up.

After switch installation

To configure your switch, after you have securely installed and powered on the S5148F-ON switch, see your open network installation environment (ONIE)-compatible operating system documentation at <https://opencomputeproject.github.io/onie/>.

Specifications

This section lists the S5148F-ON switch specifications.

CAUTION: Operate the product at an ambient temperature not higher than 0°C to 45°C (32°F to 113°F).

CAUTION: Lithium Battery Caution: There is a danger of explosion if the battery is incorrectly replaced. Replace only with same or equivalent type of battery. Dispose of the batteries according to the manufacturer's instructions.

NOTE: For RoHS information, see [Restricted Material Compliance](#).

Topics:

- Chassis physical design

Chassis physical design

Table 1. Chassis physical design

Parameter	Specifications
Height	1.72 inches (44 mm)
Width	17.1 inches (434 mm)
Depth	18.1 inches (460 mm) PSU/fan tray handle: 1.57 inches (40 mm)
Chassis weight with factory-installed components	19 lbs (2* PSUs) 8.62 kg (2* PSUs)
Rack clearance required	Front: 5 inches (12.7 cm) Back: 5 inches (12.7 cm)

Table 2. Environmental parameters

Parameter	Specifications
Operating temperature	0°C to 45°C (32°F to 113°F) continuously -5°C to 45°C (23°F to 113°F) short-term Short term is <= 1% of operational hours per year. NOTE: Reduce maximum temperature by 1°C/125 meters (1°F/228 feet) above 950 meters (3,117 feet).
Operating humidity	5% to 85% (RH), non-condensing, continuously 5% to 90% (RH), non-condensing, short term Short term is <= 1% of operational hours per year.
Storage temperature	-40°C to 70°C (-40°F to 158°F)
Storage humidity	5% to 90%, non-condensing
Maximum thermal output	470 W = 1603.7 BTU/Hr

Table 2. Environmental parameters (continued)

Parameter	Specifications
Maximum operational altitude	10,000 feet (3,048 meters)
Maximum non-operational altitude	39,370 feet (12,000 meters)
Shock	Dell Spec SV0115

Table 3. AC power requirements

Parameter	Specifications
Power supply	100–240 VAC 50/60 Hz
Maximum current draw per system	4.7A/3.9A at 100/120V AC 2.35A/1.95A at 200/240V AC
Maximum power consumption	470 Watts
Typical power consumption	200 Watts

Table 4. DC power requirements

Parameter	Specifications
Minimum and maximum input voltage range	–40.5, –48V, –60V DC
Input current at full load with fan	–40.5V/24.0A –48V/20.25A –60V/16.2A

Support

The support site provides documents and tools to help you effectively use your equipment and mitigate network outages. Through the support site you can obtain technical information, access software upgrades and patches, download available management software, and manage your open cases. The support site provides integrated, secure access to these services.

To access the support site, go to <https://www.dell.com/support/>. To display information in your language, scroll down to the bottom of the web page and select your country or region from the drop-down menu.

- To obtain product-specific information, enter the 7-character service tag, which is known as a luggage tag, or 11-digit express service code of your switch and click **Submit**.

To view the chassis service tag or express service code, pull out the tag or enter the `show chassis` command from the CLI.

- To receive more technical support, click **Contact Us**. On the Contact Information web page, click **Technical Support**.

To access switch documentation, go to <https://www.dell.com/manuals/>.

To search for drivers and downloads, go to <https://www.dell.com/drivers/>.

To participate in community blogs and forums, go to <https://www.dell.com/community>.