

Dell PowerSwitch S5148F-ON Installation Guide

June 2023

Notes, cautions, and warnings

 **NOTE:** A NOTE indicates important information that helps you make better use of your computer.

 **CAUTION:** A CAUTION indicates either potential damage to hardware or loss of data and tells you how to avoid the problem.

 **WARNING:** A WARNING indicates a potential for property damage, personal injury, or death.

Chapter 1: About this guide	5
Related documents.....	5
Information symbols.....	6
Chapter 2: S5148F-ON switch	7
Introduction.....	7
Features.....	8
Physical dimensions.....	8
LED display.....	8
LED behavior.....	9
Prerequisites.....	11
S5148F-ON switch configurations.....	11
Luggage tag.....	12
Chapter 3: Site preparations	13
Site selection.....	13
Cabinet placement.....	13
Rack mounting.....	14
Fans and airflow.....	14
Power.....	14
Storing components.....	14
Chapter 4: NEBS compliance	15
Important information.....	15
NEBS-compliant ground installation.....	15
Chapter 5: S5148F-ON switch installation	18
Rack or cabinet hardware installation.....	18
ReadyRails installation.....	19
Tool-less square-hole installation.....	19
Two-post flush-mount installation.....	20
Two-post center-mount installation.....	21
Four-post threaded installation.....	22
Switch installation.....	23
1U front-rack installation.....	23
Ground cable.....	25
Optics installation.....	25
Optics removal.....	26
Switch power-up.....	26
After switch placement.....	26
Switch replacement.....	26
Chapter 6: Power supplies	28
Components.....	28

AC or DC power supply installation.....	29
AC or DC power supply replacement.....	30
DC power supply to power source connection.....	30
Chapter 7: Fans.....	32
Components.....	32
Fan module installation.....	33
Fan module replacement.....	33
Fan air filter replacement.....	33
Chapter 8: Management ports.....	35
RS-232 console port access.....	35
MicroUSB-B console port access.....	36
USB storage mount.....	36
Before you install an OS.....	37
ONIE service discovery.....	38
Chapter 9: Specifications.....	39
Chassis physical design.....	39
IEEE standards.....	40
Agency compliance.....	41
USA Federal Communications Commission statement.....	41
European Union directive conformance statement.....	41
Japan VCCI compliance for class A equipment.....	42
Korean certification of compliance.....	42
Safety standards and compliance agency certifications.....	43
Electromagnetic compatibility	43
Product recycling and disposal.....	43
Chapter 10: Dell support.....	45

About this guide

This guide provides site preparation recommendations, step-by-step procedures for rack mounting and desk mounting your switch, inserting modules, and connecting to a power source.

CAUTION: To avoid electrostatic discharge (ESD) damage, wear grounding wrist straps when handling this equipment.

NOTE: Only trained and qualified personnel can install this equipment. Read this guide before you install and power up this equipment. This equipment contains two power cords. Disconnect both power cords before servicing.

NOTE: This equipment contains optical transceivers, which comply with the limits of Class 1 laser radiation.



Figure 1. Class 1 laser product tag

NOTE: When no cable is connected, visible and invisible laser radiation may emit from the aperture of the optical transceiver ports. Avoid exposure to laser radiation. Do not stare into open apertures.

Regulatory

Marketing model S5148F-ON is represented by the regulatory model E21W and the regulatory type E21W001.

Topics:

- [Related documents](#)
- [Information symbols](#)

Related documents

For more information about the S5148F-ON switch, see the following documents:

- *OS10 Enterprise Edition User Guide*
- *OS10 Enterprise Edition Release Notes*
- *S5148F-ON Set-up Guide*
- *S5148F-ON Release Notes*
- *Open Networking Hardware Diagnostic Guide*

NOTE: For the most recent documentation, see the Dell support site: <https://www.dell.com/support>.

Information symbols

This book uses the following information symbols:

 **NOTE:** The **Note** icon signals important operational information.

 **CAUTION:** The **Caution icon** signals information about situations that could result in equipment damage or loss of data.

 **NOTE:** The **Warning** icon signals information about hardware handling that could result in injury.

 **NOTE:** The **ESD Warning** icon requires that you take electrostatic precautions when handling the device.

S5148F-ON switch

The following sections describe the Dell S5148F-ON switch:

Topics:

- [Introduction](#)
- [Features](#)
- [Physical dimensions](#)
- [LED display](#)
- [Prerequisites](#)
- [S5148F-ON switch configurations](#)
- [Luggage tag](#)

Introduction

The S5148F-ON switch is a one rack unit, full-featured, fixed form-factor top-of-rack (ToR) compact 10/25/40/50/100GbE switch. In addition, the S5148F-ON switch has 10/25GbE links for server connections and 40/50/100GbE links for clustering—virtual link trunking (VLT) and stacking—and uplinks to aggregation and core switches. The switch includes two hot-swappable AC or DC power supply units (PSUs) and four hot-swappable fan units.

The S5148F-ON switch includes 54 SFP28 and QSFP28 ports for Ethernet-only configurations. The SFP28 ports support forty-eight 1/10/25GbE. The QSFP28 ports support six 40/100GbE.

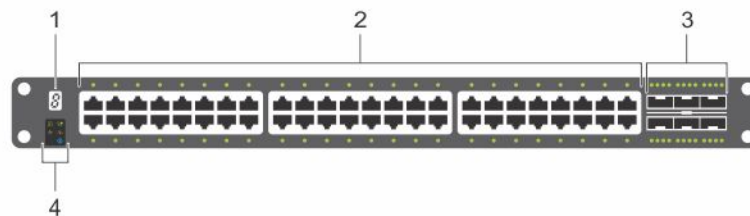

Figure 2. S5148F-ON switch I/O-side view

- | | |
|----------------------------|-------------------------------|
| 1. Stack ID | 2. Forty eight SFP28GbE ports |
| 3. Six QSFP28 100GbE ports | 4. LED Status Icons |

The S5148F-ON switch has one RJ-45 serial console port, one Micro-USB type-B console port, one 10/100/1000 Base-T Ethernet management port, and one USB type-A port for the external storage. Management ports are located on the PSU-side of the switch.

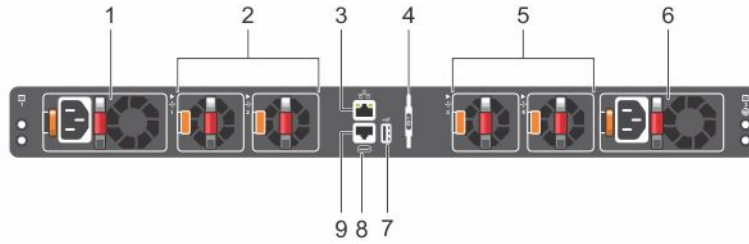

Figure 3. SS5148F-ON switch PSU-side view

- | | |
|--------------------------|------------------------|
| 1. PSU1 | 2. Fan Modules 1 and 2 |
| 3. RJ-45 management port | 4. Luggage Tag |
| 5. Fan Modules 3 and 4 | 6. PSU2 |
| 7. USB Type A | 8. MicroUSB-B Port |
| 9. RS-232 console port | |

Features

The S5148F-ON switch offers the following features:

- Forty-eight 10GbE and 25GbE SFP28 ports
- Six 40GbE and 100GbE QSFP28 ports
- One MicroUSB-B console port
- One RJ-45 serial console port
- One USB Type-A port for more file storage
- On-board Rangeley central processing unit (CPU) system with 8GB DDR III RAM, 16GB iSLC mSATA SSD
- One 10/100/1000BaseT Ethernet management port
- Two hot-swappable redundant power supplies
- Four hot-swappable fan modules
- Standard 1U switch

Physical dimensions

The S5148F-ON switch have the following physical dimensions:

- 434 x 462 x 44 mm (W x D x H)
- 17.1 x 18.2 x 1.72 inches (W x D x H)
- PSU/fan tray handle: 1.57 inches (40 mm)

LED display

The S5148F-ON switch includes LED displays on the I/O side of the switch.

NOTE: If you are installing third-party software, for LED information, see your third-party operating software (OS) documentation.

LED behavior

The following S5148F-ON switch LED behavior is seen during open networking installation environment (ONIE) operations:

S5148F-ON LEDs

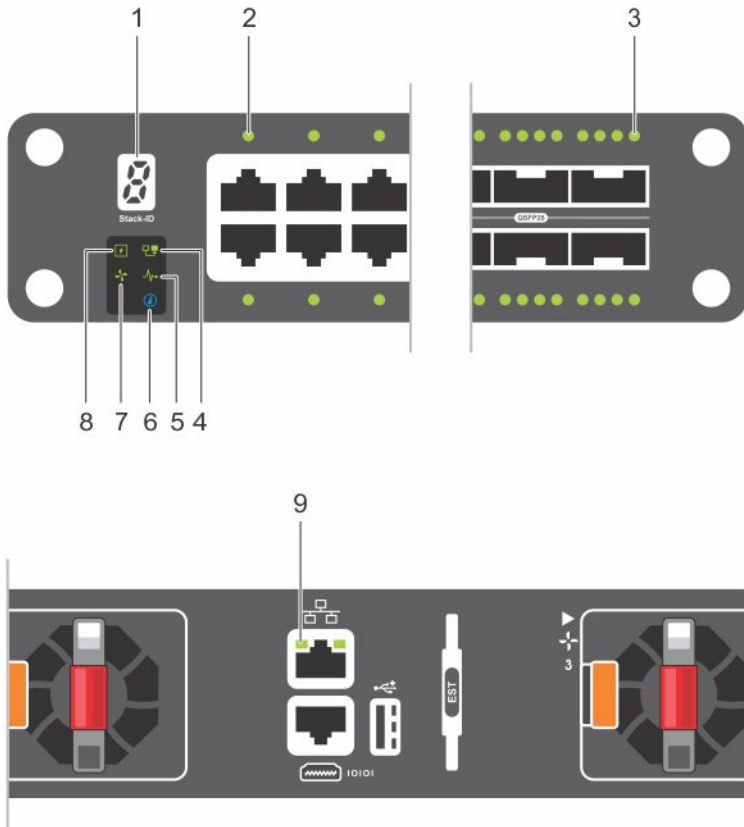

- 1. Stack ID LED
- 2. Port Activity LED
- 3. Port Activity LED
- 4. Master LED
- 5. System LED
- 6. Locator LED
- 7. Fan LED
- 8. Power LED
- 9. RJ-45 Ethernet Port LED: Left is activity; right is link.

Table 1. S5148F-ON switch LED behavior

LED	Description
System Status/Health LED	<ul style="list-style-type: none"> ● Solid green—Normal operation ● Blinking green—Booting ● Solid yellow—Critical system error ● Blinking yellow—Noncritical system error, fan failure, or power supply failure
Power LED	<ul style="list-style-type: none"> ● Off—No power ● Solid Green—Normal operation ● Solid yellow—POST is in process

Table 1. S5148F-ON switch LED behavior (continued)

LED	Description
	<ul style="list-style-type: none"> Blinking yellow—Power supply failed
Master LED	<ul style="list-style-type: none"> Off—Switch is in Stacking Slave mode Solid green—Switch is in Stacking Master or Standalone mode
FAN LED	<ul style="list-style-type: none"> Off—No power Solid green—Normal operation; fan powered and running at the expected RPM Solid yellow—Fan failed—including incompatible airflow direction when you insert the PSU or fan trays with differing airflows
PSU LED	<ul style="list-style-type: none"> Off—No power Solid green—Normal operation Solid yellow—Power supply critical event causing a shutdown Blinking yellow—PSU warning event; power continues to operate Blinking green, 1.0Hz—Standby mode Blinking green, 0.5Hz—AC power cord unplugged
LOCATOR LED/System Beacon	<ul style="list-style-type: none"> Off—Locator function disabled Blinking blue—Locator function enabled
7-Segment LED for stacking	<ul style="list-style-type: none"> Off—No power Solid green—Hex digit representing the stack unit ID
RJ-45 Ethernet Port LED	<ul style="list-style-type: none"> Off—no link and no activity detected On—Activity on the port Solid yellow—10MHz activity Solid green—100MHz activity Blinking green—1GHz activity

Table 2. System management Ethernet port LEDs

LED	Description
Link LED	<ul style="list-style-type: none"> Off—No link Solid green—Link operating at a maximum speed, autonegotiated/forced or 1G Solid yellow—Link operating at a lower speed, autonegotiated/forced or 10/100M
Port activity LED	<ul style="list-style-type: none"> Off—No link Flashing green—Port activity

NOTE: There are four LEDs for each SFP28 and QSFP28 port. For each port, 100GbE or 40GbE uses only one LED, 2x50GbE uses two LEDs, and 4x25GbE or 4x10GbE uses all four LEDs.

Table 3. SFP28 port LEDs

LED	Description
Link LED	<ul style="list-style-type: none"> Off—No link Solid green—Link operating at maximum speed, 10G Solid yellow—Link operating at a lower speed, 1G Flashing yellow, 1 second on/off—port beacon
Activity LED	<ul style="list-style-type: none"> Off—No link Flashing green—port activity

Table 4. QSFP28 port LEDs

LED	Description
Link/Activity LED—100G, 40G, or 10G	<ul style="list-style-type: none"> • Off—No link • Solid green—Link operating at maximum speed, 100G for QSFP28 port • Flashing green—Port activity operating at maximum speed, 100G for QSFP28 ports • Solid yellow—Port activity operating at a lower speed, 40G or 10G port • Flashing yellow, 1 second on/off—Port beacon
Link/Activity LED—4x25G mode or 4x10G mode	<ul style="list-style-type: none"> • Off—No link • Solid green—Link operating at maximum speed, 4x25G port • Flashing green—Link activity operating at maximum speed, 4x25G port • Solid yellow—Link operating at a lowr speed, 4x10G port • Flashing yellow, 1 second on/off—Port beacon
Link/Activity LED—2x50G mode	<ul style="list-style-type: none"> • Off—No link • Solid yellow—Link operating at a lower speed, 2x50G port • Flashing yellow—Port activity at a lower speed, 2x50G port • Flashing yellow, 1 second on/off—Port beacon

Prerequisites

The following is a list of components that are required for successful switch installation:

 **NOTE:** For detailed installation instructions, see [Site Preparations](#) and [S5148F-ON Installation](#).

- S5148F-ON switch or multiple switches, if stacking
- AC or DC country- and regional-specific cables to connect the AC or DC power source to each of the switches' AC or DC power supplies
- ReadyRail mounting brackets for rack installation, included
- Screws for rack installation
- #1 and #2 Phillips screw drivers, not included
- Torx screwdriver, not included
- Ground cable screws for L-bracket, included
- Copper/fiber cables

Other optional components are:

- M3 or M4 ground cable screw, depending on your switch
- Extra mounting brackets
- Extra power supply unit
- Extra fan module

S5148F-ON switch configurations

You can order the S5148F-ON switch in several different configurations:

- S5148F-ON AC or DC Normal Airflow: fifty-four 10/25/40/50/100GbE ports—48 SFP28 1/10/25GbE ports and 6 QSFP28 40/100GbE ports, 2 AC or DC power supplies, and 4 fan subsystems with airflow from the I/O side to the power supply side.
- S5148F-ON AC or DC Reverse Airflow: fifty-four 10/25/40/50/100GbE ports—48 SFP28 1/10/25GbE ports and 6 QSFP28 40/100GbE ports, 2 AC or DC power supplies, and 4 fan subsystems with airflow from the power supply side to the I/O side.
- Fan with airflow from the I/O side to the PSU side—normal airflow.
- Fan with airflow from the PSU side to the I/O side—reverse airflow.

- AC or DC power supply with airflow from the I/O side to the PSU side—normal airflow.
- AC or DC power supply with airflow from the PSU side to the I/O side—reverse airflow.

Luggage tag

The switch has a pull-out tag, known as a luggage tag, on the PSU-side of the switch. The front of the luggage tag includes switch ID information. The back of the luggage tag includes a QRL that takes you to a How-To site where you can watch videos about racking the switch, replacing components, configuring port channels, and so on.

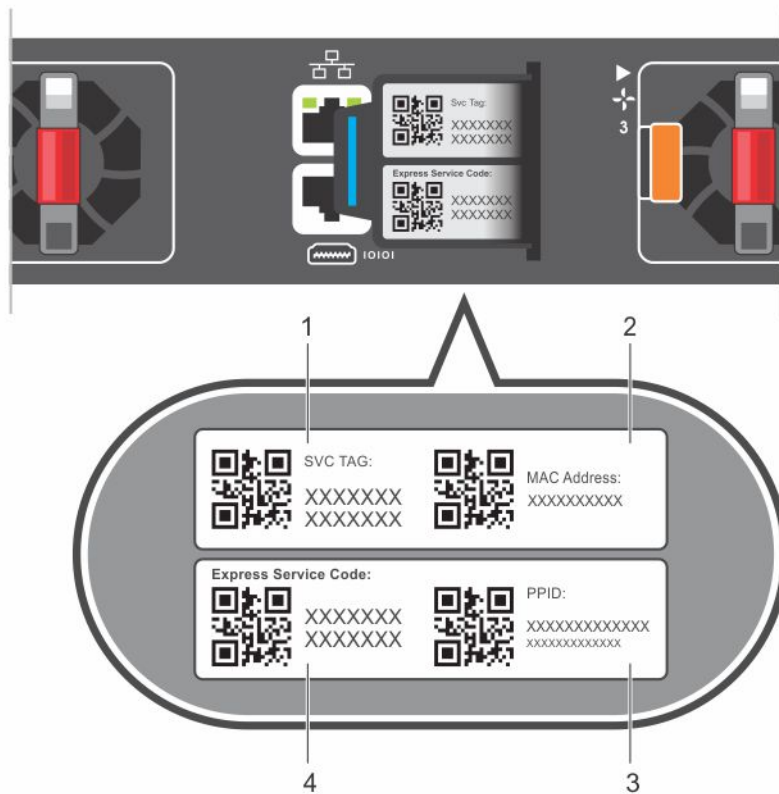

Figure 4. S5148F-ON switch luggage tag

- | | |
|----------------|-------------------------|
| 1. Service tag | 2. MAC address |
| 3. PPID | 4. Express service code |

Site preparations

The S5148F-ON switch is suitable for installation as part of a common bond network (CBN).

You can install the switch in:

- Network telecommunication facilities
- Data centers
- Other locations where the National Electric Code (NEC) applies

For more information about switch specifications, see [Specifications](#).

NOTE: Install the S5148F-ON switch in a rack or cabinet before installing the components.

Topics:

- [Site selection](#)
- [Cabinet placement](#)
- [Rack mounting](#)
- [Fans and airflow](#)
- [Power](#)
- [Storing components](#)

Site selection

Install the switch equipment in restricted access areas.

A restricted access area is one in which service personnel can only gain access using a special tool, lock, key or other means of security. The authority responsible for the location controls access to the restricted area.

Ensure that the area where you install your switch meets the following safety requirements:

- Near an adequate power source. Connect the switch to the appropriate branch circuit protection according to your local electrical codes.
- Switch environmental temperature range is from 0°C to 45°C (32°F to 113°F).
- Relative humidity is from 5 to 85 percent non-condensing.
- In a dry, clean, well-ventilated, and temperature-controlled room, away from heat sources such as hot air vents or direct sunlight.
- Away from sources of severe electromagnetic noise.
- Inside the restricted access area, positioned in a rack or cabinet, or on a desktop with adequate space in the front, back, and sides for proper ventilation and access.
- Install the switch in Information Technology Rooms in accordance with Article 645 of the National Electrical Code and NFPA 75.

For more information about switch storage and environmental temperatures, see [Specifications](#).

Cabinet placement

Install the S5148F-ON switch only in indoor cabinets designed for use in a controlled environment.

Do not install the switch in outside cabinets. For cabinet placement requirements, see [Site Selection](#).

The cabinet must meet minimum size requirements. Airflow must be in accordance with the Electronic Industries Alliance (EIA) standard. Ensure that there is a minimum of 5 inches (12.7 cm) between the intake and exhaust vents and the cabinet wall.

Rack mounting

When you prepare your equipment rack, ensure that the rack is grounded.

Ground the equipment rack to the same ground point the power service in your area uses. The ground path must be permanent.

Fans and airflow

The S5148F-ON switch fans support two airflow options: normal and reverse.

Fan combinations

Fan installation is done as part of the factory install based on stock keeping unit (SKU) type. The S5148F-ON switch has SKUs that support the following configurations:

- AC or DC PSU with fan airflow from the I/O to the PSU—the red indicator is the normal airflow direction
- AC or DC PSU with fan airflow from the PSU to the I/O—the blue indicator is the reverse airflow direction

Order the fans suitable to support your site's ventilation. Use a single type of airflow fan in your switch. Do not mix reverse and normal airflows in a single S5148F-ON switch.

For proper ventilation, position the switch in an equipment rack or cabinet with a minimum of 5 inches (12.7 cm) of clearance around the exhaust vents. When you install two S5148F-ON switches near each other, to permit proper airflow, position the two switches at least 5 inches (12.7 cm) apart. The fan speed varies based on internal temperature monitoring. The S5148F-ON switch never intentionally turns off the fans.

For more information, see [Fans](#).

Power

Connect the switch to the applicable power source using the appropriate power cord. An AC power cord is included with each PSU.

When installing AC or DC switches, follow the requirements of the National Electrical Code, ANSI/NFPA 70, where applicable.

The switch is powered-up when you connect the power cord between the switch and the power source. For more information, see [Power supplies](#).

⚠ CAUTION: Always disconnect the power cable before you service the power supply slots. The switch has multiple power cords. Before servicing, ensure all power cords are disconnected.

⚠ CAUTION: On an AC switch, use the power supply cord as the main disconnect device. Ensure that the socket-outlet is located and installed near the equipment and is easily accessible.

ℹ NOTE: Module power is software controlled. You do not see module LEDs when the switch powers up in ONIE.

Storing components

If you do not install your S5148F-ON switch and components immediately, properly store the switch and all optional components using these guidelines:

- Storage location temperature must remain constant. The storage range is from -40°C to 70°C (-40° to 158°F).
- Store on a dry surface or floor, away from direct sunlight, heat, and air conditioning ducts.
- Store in a dust-free environment.

ℹ NOTE: ESD damage can occur when components are mishandled. Always wear an ESD-preventive wrist or heel ground strap when handling the S5148F-ON switch and accessories. After you remove the original packaging, place the S5148F-ON switch and components on an anti-static surface.

NEBS compliance

For your switch to be network equipment building system (NEBS) compliant, follow the instructions detailed in this section.

To be NEBS compliant, position your switch in the rack so that the air inlet is from the front aisle and the air exhaust is to the rear aisle.

Topics:

- [Important information](#)
- [NEBS-compliant ground installation](#)

Important information

⚠ WARNING: The SFP28, QSFP28, console, Ethernet management, and universal serial bus (USB) ports are suitable for connection to intra-building or unexposed wiring or cabling only. You MUST NOT metalically connect the ports to interfaces that connect to the out side plant (OSP) or its wiring. Use these interfaces as intrabuilding interfaces only (Type 2 or Type 4 ports as described in GR-1089-CORE, Issue 6) and they require isolation from the exposed OSP cabling. Adding primary protectors is not sufficient protection to connect these interfaces metalically to OSP wiring.

⚠ WARNING: If you install and connect the S5148F-ON switch to a commercial AC power source, connect the switch to an external special protection device (SPD).

To be NEBS compliant:

- Locate your switch in a restricted-access area were only trained personnel are allowed access.
- Install and connect your switch to the common bonding network (CBN).
- You can also install and connect your switch to the central office.
- Connect the battery returns of your switch as DC-I.
- Ground your switch using a copper ground conductor.
- Clean and coat all bare grounding connection points on your switch with an antioxidant solution before making connections.
- Bring all unplated ground connection surfaces on your switch to a bright finish and treat them with an antioxidant solution before making connections.
- To ensure electrical continuity, remove any nonconductive surfaces on your switch from the ground connection points and threaded holes that secure the ground lugs.
- Use the two-hole, Listed, compression-type lug with an AWG 14 gauge wire for switch grounding.

i NOTE: The S5148F-ON switch can operate at -40.5 VDC to -60 VDC at a maximum current level of 24A.

i NOTE: The S5148F-ON switch is Earthquake Z4-compliant when you attach the ReadyRails to the four-post frame using threaded hardware. Do not use the tool-less or two-post installation methods.

NEBS-compliant ground installation

Before you install the switch into a rack, install the ground (GND) lug assembly.

Your switch includes an assembled UL-certified GND lug with bracket, which is packaged separately. If any parts are missing, contact your Dell Sales Representative.

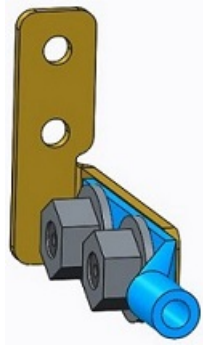

Figure 5. GND lug assembly

1. Remove the two installed M3 screws from the lower-left side of your switch.

i **NOTE:** Keep these screws.

2. Remove the bracket assembly from the shipping bag.
3. Clean the bracket and lug surfaces thoroughly and apply an antioxidant solution to the mating surfaces.
4. Attach the switch ground using the [Ground cable](#) instructions.
5. Using the two removed screws, attach the GND lug bracket assembly to your switch, as shown.
Torque the M3 screws to ± 4 -5 in-lbs.

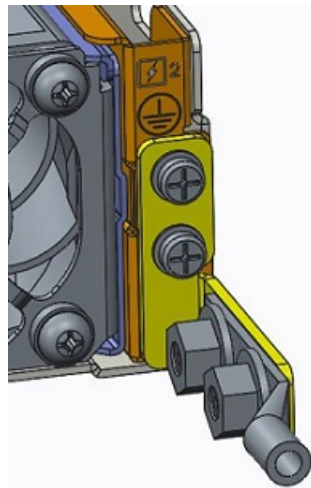

Figure 6. Attach the GND lug assembly

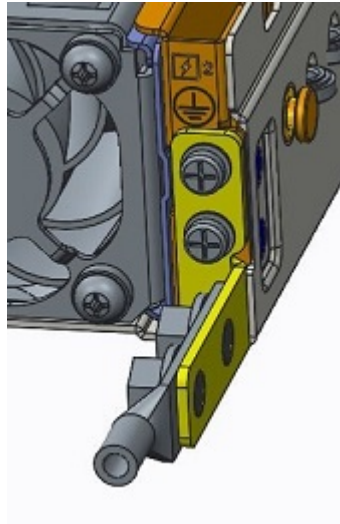

Figure 7. GND lug assembly attached

6. Install your switch into your rack using the [S5148F-ON switch installation](#) instructions.

S5148F-ON switch installation

To install the S5148F-ON switch, complete the installation procedures in the order presented in this section.

Always handle the switch and components with care. Avoid dropping the switch or its field replaceable units (FRUs).

NOTE: ESD damage can occur if components are mishandled. Always wear an ESD-preventive wrist or heel ground strap when handling the S5148F-ON switch and components. As with all electrical devices of this type, take all the necessary safety precautions to prevent injury when installing this switch.

Topics:

- [Rack or cabinet hardware installation](#)
- [ReadyRails installation](#)
- [Switch installation](#)
- [Ground cable](#)
- [Optics installation](#)
- [Switch power-up](#)
- [After switch placement](#)
- [Switch replacement](#)

Rack or cabinet hardware installation

You may either place the switch on a rack shelf or mount the switch directly into a 19" wide, EIA-310- E-compliant rack. Rack mounting includes four-post, two-post, or threaded mounts. The ReadyRails system is provided for 1U front-rack and two-post installations.

The ReadyRails system includes separately packaged rail assemblies.

CAUTION: Your switch is not NEBS Earthquake Z4-compliant if you use the 1U tool-less square-hole or two-post installation methods.

WARNING: This document is a condensed reference. Read the safety instructions in your *Safety, Environmental, and Regulatory* information booklet before you begin.

NOTE: The illustrations in this document are not intended to represent a specific switch.

NOTE: Do not use the mounted ReadyRails as a shelf or a workplace.

Rack mount safety considerations

- **Rack loading**—Overloading or uneven loading of racks may result in shelf or rack failure, possibly damaging the equipment and causing personal injury. Stabilize racks in a permanent location before loading begins. Mount the components starting at the bottom of the rack, then work to the top. Do not exceed your rack's load rating.
- **Power considerations**—Connect only to the power source specified on the unit. When you install multiple electrical components in a rack, ensure that the total component power ratings do not exceed the circuit capabilities. Overloaded power sources and extension cords present fire and shock hazards.
- **Elevated ambient temperature**—If installed in a closed rack assembly, the operating temperature of the rack environment may be greater than the room ambient temperature. Use care not to exceed the 45°C (113°F) maximum ambient temperature of the switch.
- **Reduced air flow**—Install the equipment in the rack so that the amount of airflow required for safe operation of the equipment is not compromised.
- **Reliable earthing**—Maintain reliable earthing of rack-mounted equipment. Pay particular attention to the supply connections other than the direct connections to the branch circuit, for example, use of power strips.

- Do not mount the equipment with the back panel facing downward.

ReadyRails installation

To easily configure your rack for installation of your S5148F-ON switch, use the ReadyRails rack mounting system provided.

You can install the ReadyRails system using the 1U tool-less method or one of three possible 1U tooled methods—two-post flush mount, two-post center mount, or four-post threaded mount.

CAUTION: Do not use the two-post methods if you need your switch to be NEBS Earthquake Z4-compliant.

To begin installation, separate each rail assembly by sliding the inside rail out of the outside rail.

NOTE: For more installation instructions, see the installation labels attached to the rail assembly.

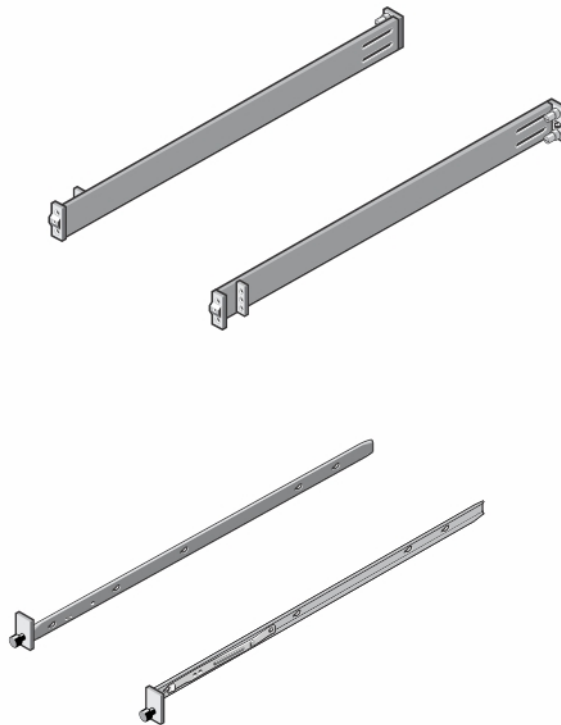

Figure 8. Separate rails

Tool-less square-hole installation

NOTE: For more installation instructions, see the installation labels attached to the rail assembly.

CAUTION: Your switch is not NEBS Earthquake Z4-compliant if you this installation method.

1. With the ReadyRails flange ears facing outward, place one rail between the left and right vertical posts. Align and seat the back flange rail pegs in the back vertical post flange. The following shows how the pegs appear in both the square and nonthreaded round holes:

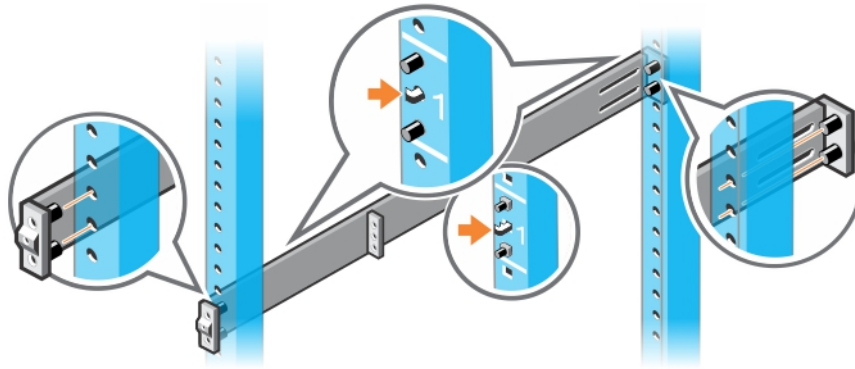

Figure 9. 1U tool-less nonthreaded square hole installation

2. Align and seat the front flange pegs in the holes on the front side of the vertical post.

NOTE: Be sure that the rails click into place and are secure.

3. Repeat this procedure for the second rail.

To remove each rail, pull on the latch release on each flange ear and unseat each rail.

Two-post flush-mount installation

NOTE: For more installation instructions, see the installation labels attached to the rail assembly.

CAUTION: Your switch is not NEBS Earthquake Z4-compliant if you this installation method.

1. For this configuration, remove the castings from the front side of each ReadyRails assembly, see item 1. Use a Torx screwdriver to remove the two screws from each front latch on the switch side of the rail. Remove the tool-less latch casting. Retain the castings for future rack requirements. Do not remove the back latch castings.

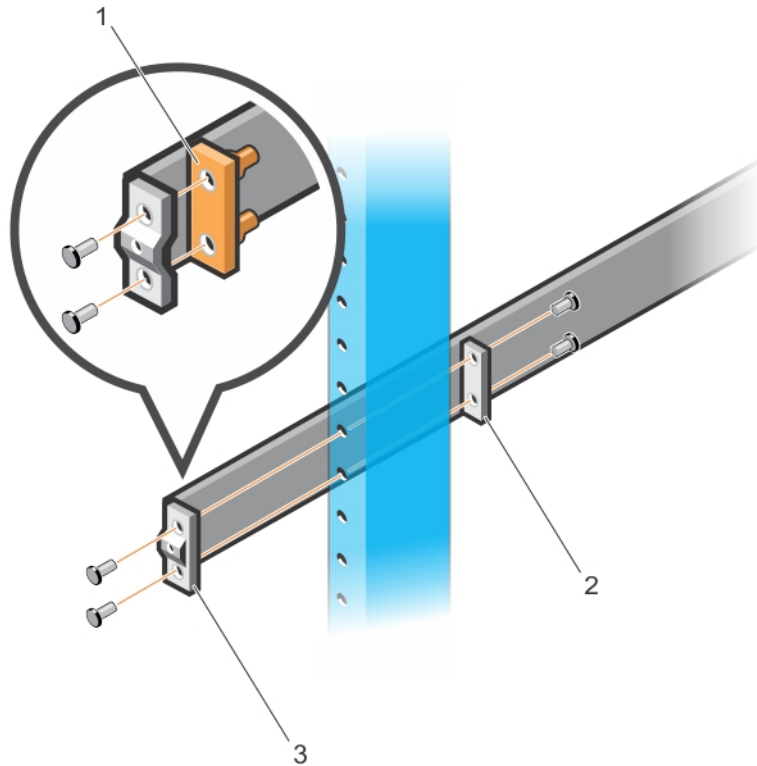

Figure 10. Two-post flush-mount configuration

2. Attach one rail to the front post flange with two user-supplied screws. See item 2.
3. Slide the plunger bracket forward against the vertical post and secure the plunger bracket to the post flange with two user-supplied screws. See item 3.
4. Repeat this procedure for the second rail.

Two-post center-mount installation

NOTE: For more installation instructions, see the installation labels attached to the rail assembly.

CAUTION: Your switch is not NEBS Earthquake Z4-compliant if you this installation method.

1. Slide the plunger bracket rearward until it clicks into place and secure the bracket to the front post flange with two user-supplied screws. See item 1.

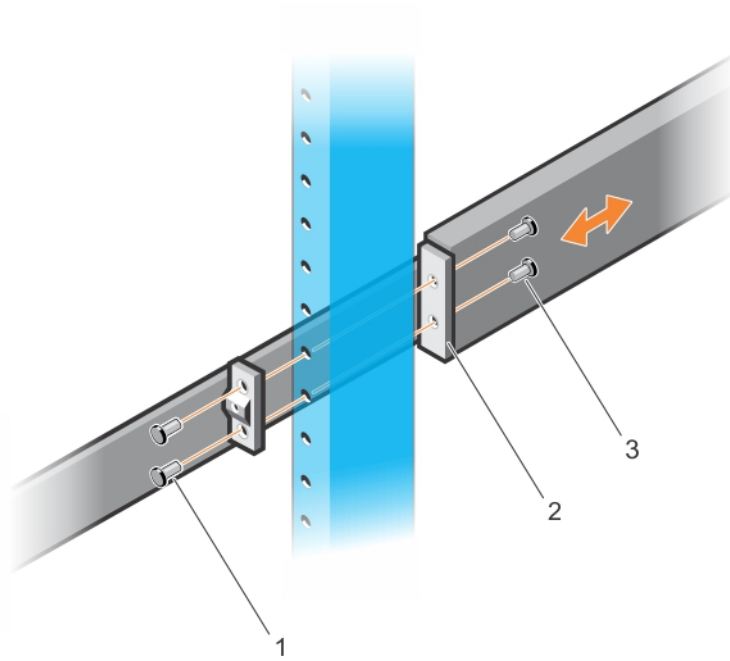

Figure 11. Two-post center-mount threaded round-hole installation

2. Slide the back bracket towards the post. Secure it to the post flange with two user-supplied screws. See item 2 and 3.
3. Repeat this procedure for the second rail.

Four-post threaded installation

NOTE: For more installation instructions, see the installation labels attached to the rail assembly.

CAUTION: To be NEBS Earthquake Z4-compliant, you must remove the tool-less latch castings described in Step 1.

1. For this installation, remove the tool-less latch castings from the front side of each ReadyRails assembly. See item 1. Use a Torx screwdriver to remove the two screws from each front latch on the switch side of the rail. Remove the tool-less latch casting. Retain the castings for future rack requirements.

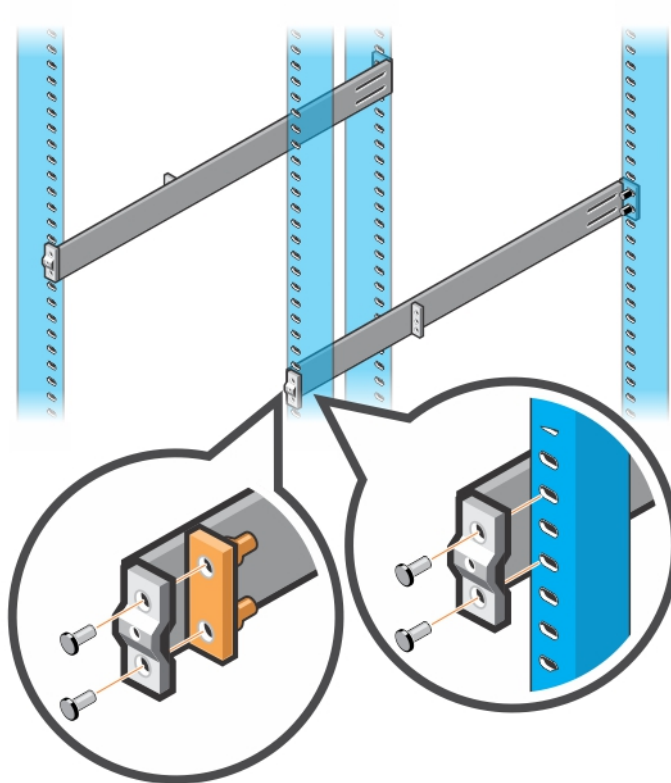

Figure 12. Four-post threaded round-hole installation

2. For each rail, attach the front and back flanges to the post flanges with two user-supplied screws at each end.

Switch installation

You can mount the switch in the 1U front-rack or 1U two-post, flush or center configuration. The following is an example of a front-rack configuration:

For the 1U two-post configurations, slide the switch into the rails in the same manner as the four-post configurations.

1U front-rack installation

Configure the rails that are attached to the switch.

NOTE: For more instructions, see the installation instruction labels on the rail.

1. Attach the inner switch rails to the S5148F-ON switch.
 - Line up the rail with the mounting heads and attach the rail to the switch.
 - Slide the rail back until it locks into place. The following shows the detail of the front standoff with the locking tab:

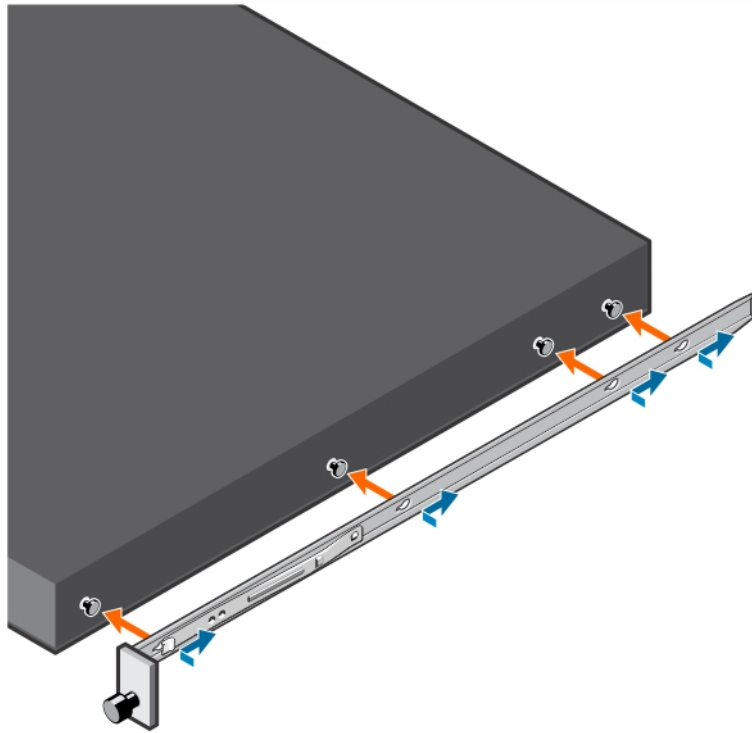

Figure 13. Attach switch rail

2. After installing both switch rails, line them up on the previously mounted ReadyRails and slide the switch in until it is flush with front of rack. To keep the switch from inadvertently sliding out of the rack and falling, about 3 inches before you fully insert your switch, the rail locking feature engages.

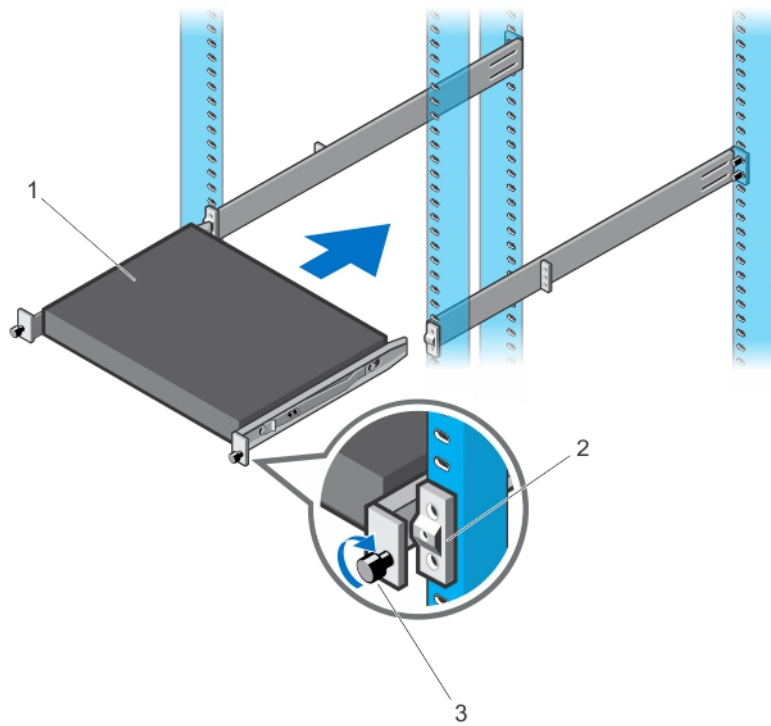



Figure 14. Front rack installation

 **NOTE:** Do not use the mounted ReadyRails as a shelf or a workplace.

3. Tighten the two thumb screws and rack screws.

To remove the switch from the rack or cabinet, press in the two side-release bars on the switch at the same time and slide the switch forward.

Ground cable

 **NOTE:** For AC-powered switches, although the third conductor of the AC power cable provides a ground path, Dell Technologies recommends grounding your switch with a dedicated ground wire.

 **NOTE:** For DC-powered switches, the only way to safely ground your switch is to attach a dedicated ground wire.

Depending on the type of switch, to attach a ground cable to the switch, you need M3 or M4 screws. The switch ships with one of the following two configurations:

- One threaded hole using an M3 screw.
- Two threaded holes using one of the two M4 screws.

In both configurations, the ground cable is not included. To properly ground the switch, Dell Technologies recommends a one- or two-hole lug, M3 or M4 hole size. The grounding lugs must be a UL-recognized, crimp-type lug.

 **CAUTION:** Grounding conductors *must* be made of copper. Do not use aluminum conductors.

 **NOTE:** Coat the one-hole lug with an antioxidant compound before crimping. Also, bring any unplated mating surfaces to a shiny finish and coat with an antioxidant before mating. Plated mating surfaces must be clean and free from contamination.

To connect the ground cable to the switch, follow these steps:

1. Cut your ground cable (not included) to the needed length. The cable length must facilitate proper operation of the fault interrupt circuits. Use the shortest cable route allowable.
2. To attach the ground cable, use one of the following:
 - Using one threaded M3 hole, attached the ground cable to the lug using an M3 screw with a captive internal tooth lock washer. Torque the screw to ± 4 -5 in-lbs.
 - Using one of the two M4 threaded holes, attach the ground cable to the lug. Use an M4 screw with a captive internal tooth lock washer. Torque the screw to ± 5 -6 in-lbs.
3. Attach the other end of the ground cable to a suitable ground point such as the rack or cabinet.
The rack installation ears are not a suitable grounding point.

Optics installation

The S5148F-ON switch has SFP28 and QSFP28 optical ports.

For a list of supported optics, see the specification sheets at <https://www.dell.com/support> or contact your Dell Sales representative.

 **CAUTION:** ESD damage can occur if components are mishandled. Always wear an ESD-preventive wrist or heel ground strap when handling the S5148F-ON switch and components.

 **WARNING:** When working with optical fibers, follow all warning labels and always wear eye protection. Never look directly into the end of a terminated or unterminated fiber or connector as it may cause eye damage.

1. Position the optic to enter the port correctly.
The optic has a key that prevents it from being inserted incorrectly.

2. Insert the optic into the port until it gently snaps into place.

 **NOTE:** When you cable the ports, be sure not to interfere with the airflow from the small vent holes above and below the ports.

Optics removal

Remove an optic by pushing the tab on the optic and sliding the optic from the port.

When removing optics with direct attach cables (DACs) from the port, pull the release tab firmly and steadily. Before pulling the release tab, you may need to gently push the optic into the port to ensure that it is seated properly. Do not jerk or tug repeatedly on the tab.

Switch power-up

Supply power to the S5148F-ON switch after it is mounted in a rack or cabinet.

Dell Technologies recommends reinspecting your switch before powering it up. Verify the following:

- Optional: The equipment is properly secured to the rack and properly grounded.
- Optional: The equipment rack is properly mounted and grounded.
- The ambient temperature around the unit, which may be higher than the room temperature, is within the limits that are specified for the S5148F-ON switch. For more information, see [Specifications](#).
- There is sufficient airflow around the unit.
- The input circuits are correctly sized for the loads and that you use sufficient overcurrent protection devices.
- All protective covers are in place.

 **CAUTION:** Do not power on the switch if you did not install a fan module.

 **NOTE:** A US AC or DC power cable is included for powering up an AC or DC power supply. You must order all other power cables separately.

 **NOTE:** ESD damage can occur if components are mishandled. Always wear an ESD-preventive wrist or heel ground strap when handling the S5148F-ON switch and components.

Power up sequence

When the switch powers up, the fans immediately come on at high speed. The fan speed slows as the switch continues to boot.

After switch placement

After you have securely installed and powered on the S5148F-ON switch, for more information:

- If you are using Dell software, see switch documentation at <https://www.dell.com/support/>.
- If you need ONIE information, see ONIE documentation at <https://opencomputeproject.github.io/onie/>.
- If you are using third-party software, see your third-party software documentation.

Switch replacement

The following steps describe removing and replacing a switch. For further assistance when replacing a switch, contact your Dell support representative.

 **NOTE:** ESD damage can occur when components are mishandled. Always wear an ESD-preventive wrist or heel ground strap when handling the switch and accessories. After you remove the original packaging, place the switch and components on an anti-static surface.

1. Back up the switch configuration to your back-up system or laptop TFTP server.

```
copy running-config tftp://hostip/filepath
```

To establish a console connection to the switch CLI, assign an IP address on the switch network.

2. Disconnect the power source.
3. Label and remove all cables.
4. Remove the switch from the rack.

Simultaneously, press in the two side-release bars on the switch and slide the switch forward.

If you are using the fan trays or PSUs in the replacement switch, remove them from the switch.

5. Unpack the new switch.

6. Confirm that the software version of the replacement switch is the same as the previously installed switch.

```
show os-version
```

If the software versions do not match, upgrade the replacement switch software using the procedure included with the firmware download.

7. Copy the backed-up switch configuration to the new switch.

```
copy tftp://hostip/filepath running-config
```

8. Install the new switch in your rack or cabinet.

For detailed installation instructions, see [S5148F-ON switch installation](#).

If you are using the fan trays or PSUs from the removed switch, reinsert them in the replacement switch.

9. Connect all the cables.

10. Power on the switch.

For more information, see [Switch power up](#).

Power supplies

The S5148F-ON switch ships with two AC or DC power supplies. The two power supplies have two air-flow directions—from the I/O to the PSU and from the PSU to the I/O.

Two PSUs are required for full redundancy, but the switch can operate with a single PSU.

The PSUs are field replaceable. When running with full redundancy—two power supplies installed and running—you can remove and replace one PSU without disrupting traffic.

CAUTION: To prevent electrical shock, ensure that the S5148F-ON switch is grounded properly. If you do not ground your equipment correctly, excessive emissions may result. Use a qualified electrician to ensure that the power cables meet your local electrical requirements.

NOTE: Connect the power supply to the appropriate branch circuit protection as defined by your local electrical codes. Verify that the remote power source complies with the switch input power specifications.

NOTE: If you use a single PSU, install a blank plate in the other PSU slot. Use power supply 2 (PSU2) as the blank plate slot. To install the blank plate, use a #1 Philips screw driver.

NOTE: ESD damage can occur if components are mishandled. Always wear an ESD-preventive wrist or heel ground strap when handling the S5148F-ON switch and components.

Topics:

- [Components](#)
- [AC or DC power supply installation](#)
- [DC power supply to power source connection](#)

Components

The following power supply options are available for the S5148F-ON switch:

- AC or DC power supply with integrated fan
- AC or DC power supply with integrated reverse flow fan

Power supply 1 (PSU1) is on the left side of the switch; power supply 2 (PSU2) is on the right side of the switch.



Figure 15. S5148F-ON PSUs

- 1—PSU modules

The PSUs have an integrated fan, which you cannot replace individually; if the fan integrated in a PSU fails, you must replace the entire PSU. You can replace the fan trays individually. For fan tray replacement procedures, see [Fans](#).

WARNING: Prevent exposure and contact with hazardous voltages. Do not attempt to operate this switch with the safety cover removed.

CAUTION: Remove the power cable from the PSU before removing the PSU. Also, do not connect the power cable before you insert the PSU in the switch.

NOTE: To comply with the GR-1089 Lightning Criteria for Equipment Interfacing with AC or DC Power Ports, use an external surge protection device (SPD) at the AC or DC input of the router.

PSU LEDs

- Solid green—Input is OK.
- Flashing yellow—There is a fault with the PSU.
- Flashing green blink at 1Hz—Switch is in a standby/CR state.
- Off—PSU is off.

AC or DC power supply installation

NOTE: The PSU slides into the slot smoothly. Do not force a PSU into a slot as this action may damage the PSU or the switch.

NOTE: Ensure that you correctly install the PSU. When you install the PSU correctly, the power connector is on the left side of the PSU.

NOTE: If you use a single PSU, install a blank plate in the other PSU slot. If you are only using one power supply, install the power supply in the first slot, PSU1. Install a blank plate in the second slot, PSU2.

1. Remove the PSU slot cover from the S5148F-ON switch using a small #1 Phillips screwdriver.
2. Remove the PSU from the electro-static bag.
3. Insert the PSU into the switch PSU slot—insert the exposed PSU connector first.

The PSU slot is keyed so that you can only fully insert the PSU in one orientation. When you install the PSU correctly, it snaps into place and is flushed with the back of the switch.

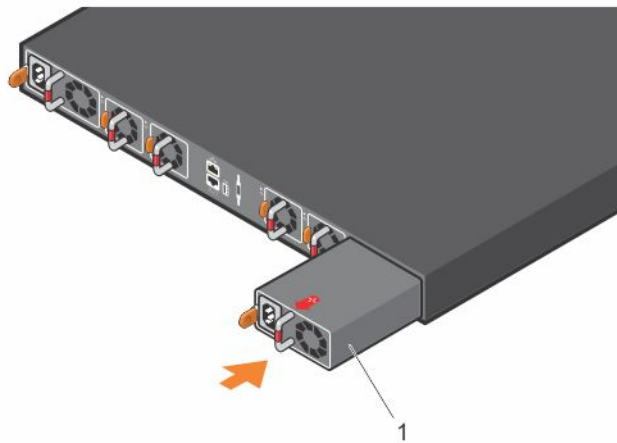

Figure 16. PSU installation

4. Plug in the appropriate AC 3-prongs cord from the switch PSU to the external power source.
5. Repeat steps 1 through 4 if you have a redundant PSU using the second PSU slot on the S5148F-ON switch.

NOTE: The S5148F-ON switch powers up when you connect the cables between the power supply and the power source.

AC or DC power supply replacement

CAUTION: Disconnect the power cable before removing the power supplies. Also, disconnect all power cables before servicing.

- NOTE:** The PSU slides into the slot smoothly. Do not force a PSU into a slot as this action may damage the PSU or the S5148F-ON switch.
- NOTE:** If a PSU fails, you must replace the entire unit. There are no field serviceable components in the PSU. To request a hardware replacement, see [Dell support](#).
- NOTE:** If you use a single PSU, install a blank plate in the other PSU slot. If you are only using one power supply, install the power supply in the first slot, PSU1. Install a blank plate in the second slot, PSU2.

1. Disconnect the power cable from the PSU.
2. Use the grab handle to slide the PSU out of the power supply bay.
3. Use the grab handle on the replacement PSU to slide it into the power supply bay.
4. Attach the power cable to the replacement PSU.

NOTE: The switch powers up when the cables are connected between the power supply and the power source.

DC power supply to power source connection

Each DC powered switch comes with a set containing a prewired, 3-inch 8 AWG, power supply connector and a four-screw wiring block. One set is provided for each DC PSU.

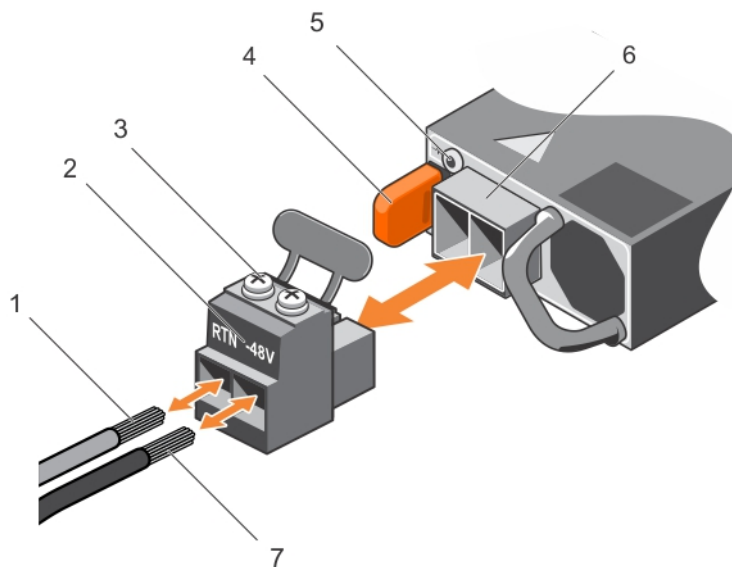

Figure 17. DC power connector and wiring block

1. DC wire RTN
2. DC power connector
3. Captive screws (2)
4. Orange tab
5. PSU status LED
6. DC power socket
7. DC wire -48V

1. Strip 0.5 inches of insulation from each of the power connector's wires, RTN and -48V.
2. Insert each of the power connector's bare wire lengths into the wiring block. Insert RTN into one hole and -48V into the other hole.
3. Use a flat-blade screwdriver to tighten the screws that secures the bare wires into the wiring block.
4. Secure the site's DC power source wires to the other side of the wiring block, see steps 1 and 3.

 **WARNING:** Do not cross the wires. In the wiring block, RTN aligns with RTN and –48V aligns with –48V.

5. Insert the DC power connector into the power socket of the DC PSU. Ensure that the connector pins firmly seat and you hear the click of the power connector's left and right levered clamps lock into place.

 **WARNING:** Never try to force the power connector into or out of the DC PSU power socket.

 **NOTE:** To remove the power connector from a DC PSU, use the orange tab on the side of the connector. Doing so disengages the power connector's clamps. After engaging the orange tab, pull the power connector from the DC PSU socket.

Fans

The S5148F-ON switch comes from the factory with two PSUs and four fan modules installed in the switch. The fan modules and the power supplies, which have integrated fans, are hot-swappable.

In addition to the power supply modules, you can order and install fan modules separately.

The S5148F-ON switch supports two airflow direction options. Do not mix airflow types in a switch; you can use only a single airflow direction in a switch. If the airflow directions are mismatched, *you must correct the mismatched airflow direction*.

- Airflow is from the I/O panel to the PSU—the red indicator is the normal airflow direction.
- Airflow is from the PSU to the I/O panel—the blue indicator is the reverse airflow direction.

All fans and PSUs in a configuration must be in the same airflow direction.

Environmental factors can decrease the amount of time required between fan replacements. Check the environmental factors regularly. An increase in temperature and/or particulate matter in the air might affect performance—for example, new equipment installation).

CAUTION: Check the fans at six-month intervals and replace them as necessary. Regularly monitor the speeds of the fans to accurately determine replacement intervals.

Topics:

- [Components](#)
- [Fan module installation](#)

Components

The following are the S5148F-ON switch fan components:

- S5148F-ON switch fan module
- S5148F-ON switch fan module—reverse flow



Figure 18. S5148F-ON switch fan modules

- 1—Fan modules

Fan LEDs

- Solid green—Fan function is normal.
- Flashing yellow—There is a fan fault.
- Off—Fan is off.

Fan module installation

The fan modules in the S5148F-ON switch are field replaceable. Module slot 1 is on the left side of the switch; module slot 4 is on the right side of the switch.

CAUTION: DO NOT mix airflow directions. All fans must use the same airflow direction—reverse or normal. If you mix the airflow direction, to avoid damage to the switch, you must correct the mixed airflow.

1. Take the fan module out of the shipping box.
2. Slide the module into the bay.

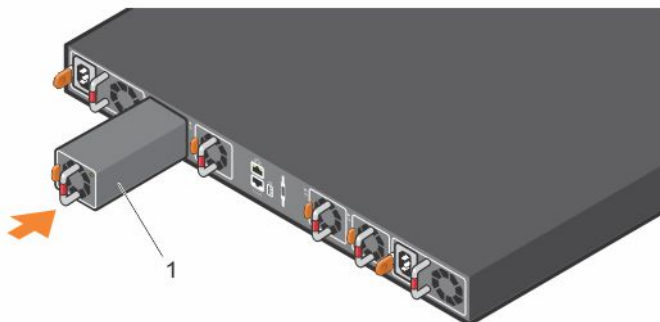

Figure 19. Fan module installation

- 1—Fan module

Fan module replacement

To request a hardware replacement, see [Dell support](#).

CAUTION: Complete the following steps within one minute or the switch temperature could rise above safe thresholds and the switch could shut down:

1. Slide the fan module out of the bay.
2. Slide the replacement module into the bay.

Fan air filter replacement

Environmental factors can decrease the amount of time required between air filter replacements. Check the environmental factors regularly. An increase in temperature and/or particulate matter in the air might affect performance.

CAUTION: Check the fan air filters at six-month intervals and replace them as necessary. To accurately determine air filter replacement intervals, regularly monitor the speeds of the cooling fans. An increase in overall fan speed may indicate a clogged filter.

You must replace the fan air filters with new filters; you cannot clean and reuse the old fan air filters. Replacement filter media must meet the requirements found in GR-63-CORE.

- Minimum dust arrestance of 65%, per ASHRAE Standard 52.1-1992. OR
- Minimum Efficiency Rating Value (MERV) of 2, per ANSI/ASHRAE Standard 52.2-2007.

CAUTION: For Network Equipment Building Systems (NEBS) compliance, use NEBS-approved filters.

Use fan air filters with reverse blue-banded air flow switches—PSUs and fans. You can replace the air filters individually on each fan within the switch without powering down a PSU module or disrupting traffic.

The fan air filter media slides into the frame from the top. No tools are required.

1. Determine which filters to replace.

2. Unlatch and remove the first module that needs the filter replaced.
3. Slide the existing filter upwards to remove it from the module.
4. Replace the filter with a new filter of the same size.
5. Reinsert the fan module.
6. Repeat for the remaining modules that need the filter replaced.

Management ports

Besides the 10/100/1000Base-T RJ-45 ports, the S5148F-ON switch provides several ports for management and storage.

NOTE: The output examples in this section are for reference only. Your output may vary.

Topics:

- [RS-232 console port access](#)
- [MicroUSB-B console port access](#)
- [USB storage mount](#)
- [Before you install an OS](#)
- [ONIE service discovery](#)

RS-232 console port access

The RS-232 console port is on the PSU-side of the S5148F-ON switch.

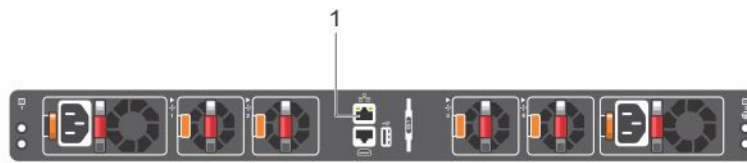

Figure 20. S5148F-ON switch RS-232 console and management ports

1. Out-of-band network management port (top); RS-232 serial console port (bottom)

CAUTION: Ensure that any equipment attached to the serial port can support the required 115200 baud rate.

NOTE: When connecting the RJ45 console to the patch panel or terminal server using Cat5e or Cat6 Ethernet cables, the maximum cable length is 100m. However, if the Ethernet cable is disconnected from the patch panel or terminal server but connected to the RJ45 console, the maximum cable length is 6m. If the cable is longer than 6m when disconnected from the panel or server, your switch may not boot.

NOTE: Before starting this procedure, ensure that your PC has a 9-pin serial port and that you have installed a terminal emulation program on the PC.

NOTE: If your PC's serial port cannot accept a female DB-9 connector, use a DB-9 male-to-male adaptor.

1. Install the provided RJ-45 connector-side of the provided cable into the switch console port.
2. Install the DB-9 female-side of the provided copper cable into your PC's serial port. Or install the DB-9 cable into other data terminal equipment (DTE) server hardware.
3. Keep the default terminal settings on the console as follows:
 - 115200 baud rate
 - No parity
 - 8 data bits
 - 1 stop bit
 - No flow control

MicroUSB-B console port access

The MicroUSB-B console port is on the PSU side of the switch.

NOTE: The S5148F-ON switch uses the Silicon Labs CP2109 USB-B chip. To find the correct USB-B universal asynchronous receiver-transmitter (UART) driver, see <https://www.silabs.com/products/development-tools/software/usb-to-uart-bridge-vcp-drivers>.

When you connect the microUSB-B port, it becomes the primary connection and, while connected, all messages are sent to the microUSB-B port.

1. Power on the PC.
2. Connect the USB-A end of cable into an available USB port on the PC.
3. Connect the microUSB-B end of cable into the microUSB-B console port on the switch.
4. Power on the switch.
5. Install the necessary USB device drivers.
6. Open your terminal software emulation program to access the switch.
7. Confirm that the terminal settings on your terminal software emulation program are as follows:
 - 115200 baud rate
 - No parity
 - 8 data bits
 - 1 stop bit
 - No flow control

USB storage mount

USB storage does not automatically mount. USB storage supports the FAT file system. To use USB storage, first mount the device using the following steps:

1. Create a mount directory for the USB storage.
ONIE:/ # mkdir /mnt/usb
2. View the fixed disks using the fdisk command.
ONIE:/mnt # fdisk -l

For internal storage:

```
Disk /dev/sda: 15.8 GB, 15829303296 bytes
255 heads, 63 sectors/track, 1924 cylinders
Units = cylinders of 16065 * 512 = 8225280 bytes

   Device Boot      Start         End      Blocks   Id  System
/dev/sda1                1         1925     15458303+  ee  EFI GPT
```

For USB storage:

```
Disk /dev/sdb: 30.9 GB, 30942946304 bytes
64 heads, 32 sectors/track, 29509 cylinders
Units = cylinders of 2048 * 512 = 1048576 bytes

   Device Boot      Start         End      Blocks   Id  System
```

3. Mount the device /dev/sdb to the /mnt/usb directory.
ONIE:/ # mount -t vfat /dev/sdb /mnt/usb

NOTE: The following message displays if the /mnt/usb directory is missing: mount: mounting /dev/sdb on /mnt/usb failed: No such file or directory.

NOTE: The following message displays if the USB device is not seen: mount: mounting /dev/sdb on /mnt/usb failed: No such device or address.

4. Optional: Add a device to the file systems table using the `fstab` command. Mount the file systems.

```
ONIE:/ # vi /etc/fstab

# FSTAB entry for the ONIE-BOOT partition mounted on /boot
LABEL=ONIE-BOOT /mnt/onie-boot ext4 defaults,rw,errors=remount-ro 0 1
/dev/sdb /mnt/usb vfat defaults 0 1

ONIE:/ # mount -a
```

The `mount -a` command mounts all the file systems as indicated in the `/etc/fstab` file.

Before you install an OS

After powering on the S5148F-ON switch, it goes through a power-on self-test (POST).

POST runs every time that the switch is initialized and checks the hardware components to determine if the switch is fully operational before booting. After POST, the switch uses the Grub bootloader.

To select an entry, use the up and down arrow keys. Press **Enter** to select an OS or enter `e` to edit the commands before booting. Enter `c` for a command line. The selected entry runs automatically in the operating system.

Grub bootloader example

```
GNU GRUB version 2.02~beta2+e4a1fe391

+-----+
|*ONIE: Install OS          |
| ONIE: Rescue              |
| ONIE: Uninstall OS       |
| ONIE: Update ONIE        |
| ONIE: Embed ONIE         |
| EDA-DIAG                  |
|                             |
+-----+
```

Your switch comes with ONIE installed.

NOTE: To access ONIE, use the RJ45 console port.

ONIE example

```
ONIE: Install OS
  For downloading and installing an OS from a URL
  Starts ONIE with ONIE Discovery Service
  (factory default boot)
ONIE: Rescue
  Starts ONIE without ONIE Discovery Service
  Useful for running Diagnostics manually
ONIE: Uninstall OS
  Restore to factory defaults erases any installed OS
ONIE: Update ONIE
  For downloading and updating ONIE from a URL
ONIE: Embed ONIE
  For downloading and updating ONIE from a URL and erases any installed OS
```

During the initial setup, the switch boots to ONIE Install. ONIE Install boots with ONIE Discovery to the console, `ONIE:.`

NOTE: For more information, see the *Open Networking Hardware Diagnostic Guide*.

NOTE: After you have securely installed and powered on the S5148F-ON switch, to configure your switch, see your third-party ONIE-compatible OS or the Dell OS documentation.

ONIE service discovery

ONIE attempts to locate the installer through several discovery methods, as shown. To download and run an installer, the ONIE Service Discovery feature uses the first successful method found.

1. Search locally attached storage devices for one of the ONIE default installer filenames—for example, the filename is: `onie self update` from the USB.
2. Query to the IPv4 and IPv6 link-local neighbors using HTTP for an installer.
3. Exact URLs from DHCPv4.
4. Discover TFTP-based image from the DHCP server.

If none of the ONIE Service Discovery methods are successful, you can disable this using the `onie-discovery-stop` command.

You can install an operating system manually from HTTP, FTP, or TFTP using the `onie-nos-install <URL>` command.

NOTE: If you have a recovery USB plugged into your switch, you must remove it before installing the DIAG-OS using the `onie-nos-install` command.

The ONIE Install environment uses DHCP to assign an IP address to the management interface—eth0. If that fails, it uses the default IP address 192.168.3.10/255.255.255.0.

To display the IP address, use the `ifconfig eth0` command, as shown.

```
ONIE:/ # ifconfig eth0
eth0 Link encap:Ethernet HWaddr 90:B1:1C:F4:9C:76
  inet addr:10.11.53.33 Bcast:10.255.255.255 Mask:255.0.0.0
  inet6 addr: fe80::92b1:1cff:fef4:9c76/64 Scope:Link
  UP BROADCAST RUNNING MULTICAST MTU:1500 Metric:1
  RX packets:18 errors:0 dropped:0 overruns:0 frame:0
  TX packets:24 errors:0 dropped:0 overruns:0 carrier:0 collisions:0 txqueuelen:1000
  RX bytes:1152 (1.1 KiB) TX bytes:6864 (6.7 KiB)
  Interrupt:21 Memory:ff300000-ff320000
```

To assign an IP address to the management interface, eth0, and verify network connectivity, use the `ifconfig eth0 <ip address>` command, as shown.

```
ONIE:/ # ifconfig eth0 10.11.53.33/16 UP

Verify the network connection with ping.
ONIE:/ # ping 10.11.8.12
PING 10.11.8.12 (10.11.8.12): 56 data bytes
64 bytes from 10.11.8.12: seq=0 ttl=62 time=1.357 ms
64 bytes from 10.11.8.12: seq=1 ttl=62 time=0.577 ms
^C
```

Specifications

This section lists the S5148F-ON switch specifications.

CAUTION: Operate the product at an ambient temperature not higher than 45°C (113°F).

CAUTION: Lithium Battery Caution: There is a danger of explosion if the battery is incorrectly replaced. Replace only with same or equivalent type of battery. Dispose of the batteries according to the manufacturer's instructions.

NOTE: For RoHS information, see [Restricted Material Compliance](#).

Topics:

- Chassis physical design
- IEEE standards
- Agency compliance
- USA Federal Communications Commission statement
- European Union directive conformance statement
- Japan VCCI compliance for class A equipment
- Korean certification of compliance
- Safety standards and compliance agency certifications
- Electromagnetic compatibility
- Product recycling and disposal

Chassis physical design

Table 5. Chassis physical design

Parameter	Specifications
Height	1.72 inches (44 mm)
Width	17.1 inches (434 mm)
Depth	Chassis: 18.2 inches (462 mm) PSU/fan tray handle: 1.57 inches (40 mm)
Chassis weight with factory-installed components	19 lbs (2* PSUs) 8.62 kg (2*PSUs)
Rack clearance required	Front: 5 inches (12.7 cm) Back: 5 inches (12.7 cm)

Table 6. Environmental parameters

Parameter	Specifications
Operating temperature	0°C to 45°C (32°F to 113°F) -5°C to 45°C (23°F to 113°F) short-term Short term is $\leq 1\%$ of operational hours per year.

Table 6. Environmental parameters (continued)

Parameter	Specifications
	 NOTE: Reduce maximum temperature by 1°C/125 meters (1°F/228 feet) above 950 meters (3,117 feet).
Operating humidity	5% to 85% (RH), non-condensing, continuously 5% to 90% (RH), non-condensing, short term Short term is $\leq 1\%$ of operational hours per year.
Storage temperature	-40°F to 70°C (-40°F to 158°F)
Storage humidity	5% to 90%, non-condensing
Maximum thermal output	470 W = 1603.7 BTU/Hr
Maximum operational altitude	10,000 feet (3,048 meters)
Maximum non-operational altitude	39,370 feet (12,000 meters)
Shock	Dell Spec SV0115

Table 7. AC power requirements

Parameter	Specifications
Power supply	100–240 VAC 50/60 Hz
Maximum current draw per switch	4.7A/3.9A at 100/120V AC 2.35A/1.95A at 200/240V AC
Maximum power capability	470 Watts
Typical power consumption	200 Watts

Table 8. DC power requirements

Parameter	Specifications
Minimum/maximum input voltage range	-40.5, -48V, -60V
Input power at full load	-40.5V/460W, -48V/930W, -60V/950W, without fan -40.5V/470W -48V/940W -60V/ 960W, with fan
Input current at full load	-40.5V/23.8A -48V/19.0A -60V/ 15.6A, without fan -40.5V/24.0A -48V/19.2A -60V/ 16.0A, with fan

IEEE standards

The S5148F-ON switch complies with the following IEEE standards.

- 802.1ab (LLDP)
- 802.1ax (Layer 2)
- 802.1d, 802.1w, 802.1s, 802.1x (Mgmt/Security), 802.3x (Layer 2)
- 802.3 (1000BASE-KX)
- 802.3ba (40GbE and 100GbE ports)

Agency compliance

The S5148F-ON switch is designed to comply with the following safety and agency requirements:

USA Federal Communications Commission statement

This equipment has been tested and found to comply with the limits for a Class A digital device, pursuant to Part 15 of the Federal Communications Commissions (FCC) rules. These limits are designated to provide reasonable protection against harmful interference when the equipment is operated in a commercial environment. This equipment generates, uses, and can radiate radio frequency energy. If it is not installed and used in accordance to the instructions, it may cause harmful interference to radio communications. Operation of this equipment in a residential area is likely to cause harmful interference, in which case users will be required to take whatever measures necessary to correct the interference at their own expense.

Properly shielded and grounded cables and connectors must be used in order to meet FCC emission limits. Dell is not responsible for any radio or television interference caused by using other than recommended cables and connectors or by unauthorized changes or modifications in the equipment. Unauthorized changes or modification could void the user's authority to operate the equipment.

This device complies with Part 15 of the FCC Rules. Operation is subject to the following two conditions: (1) this device may not cause harmful interference, and (2) this device must accept any interference received, including interference that may cause undesired operation.

Industry Canada Class A emission compliance statement

This Class A digital apparatus complies with Canadian ICES-003.

Avis de conformité à la réglementation d'Industrie Canada

Cet appareil numérique de la classe A est conforme à la norme NMB-003 du Canada.

Figure 21. Canadian Department of Communication Statement

European Union directive conformance statement

This product is in conformity with the protection requirements of EU Council Directive 2004/108/EC on the approximation of the laws of the Member States relating to electromagnetic compatibility. Dell cannot accept responsibility for any failure to satisfy the protection requirements resulting from a non-recommended modification of this product, including the fitting of non-Dell option cards.

This product has been tested and found to comply with the limits for Class A Information Technology Equipment according to CISPR32/CISPR34 and EN55032/EN55034. The limits for Class A equipment were derived for commercial and industrial environments to provide reasonable protection against interference with licensed communication equipment.

 **NOTE:** This is a Class A product. In a domestic environment, this device may cause radio interference, in which case, you may be required to take adequate measures.

European Community Contact

Dell, EMEA - Central

Dahlenweg 19

66265 Heusweiler

Germany

Tel: +49 172 6802630

Email: EMEA Central Sales

Japan VCCI compliance for class A equipment

この装置は、情報処理装置等電波障害自主規制協議会（VCCI）の基準に基づくクラスA情報技術装置です。この装置を家庭環境で使用すると電波妨害を引き起こすことがあります。この場合には使用者が適切な対策を講ずるよう要求されることがあります。

Figure 22. Japan: VCCI compliance for class A equipment

This is Class A product based on the standard of the Voluntary Control Council For Interference by Information Technology Equipment (VCCI). If this equipment is used in a domestic environment, radio disturbance may arise. When such trouble occurs, the user may be required to take corrective actions.

NOTE: Use the AC power cords with Dell equipment only. Do not use Dell AC power cords with any unauthorized hardware.

本製品に同梱いたしております電源コードセットは、本製品専用です。本電源コードセットは、本製品以外の製品ならびに他の用途でご使用いただくことは出来ません。製品本体には同梱された電源コードセットを使用し、他製品の電源コードセットを使用しないで下さい。

Figure 23. Japan: warning label

Korean certification of compliance

<p>A급 기기 (업무용 방송통신기자재)</p>	<p>이 기기는 업무용(A급) 전자파적합기기로서 판매자 또는 사용자는 이 점을 주의하시기 바라며, 가정외의 지역에서 사용하는 것을 목적으로 합니다.</p>
--------------------------------	--

Figure 24. Korean certification of compliance

	 [equipment type]
품명(Product Name)	Ethernet Switch
모델명(Model)	[model number]
신청인(Applicant)	Dell Technologies
제조사(Manufacturer)	[Manufacturer]
제조년월(Manufacturing Date)	[date]
제조국(Country of Origin)	China

Figure 25. Korean package label

Safety standards and compliance agency certifications

- CUS UL 60950-1, 2nd Edition
 - Meets or exceeds Hi Pot and Ground Continuity testing per UL 60950-1.
- CSA 60950-1-03, 2nd Edition
- EN 60950-1, 2nd Edition
- EN 60825-1, 1st Edition
- EN 60825-1 Safety of Laser Products—Part 1: Equipment Classification Requirements and User's Guide
- EN 60825-2 Safety of Laser Products—Part 2: Safety of Optical Fibre Communication Systems
- FDA Regulation 21CFR 1040.10 and 1040.11
- IEC 60950-1, 2nd Ed, including all National Deviations and Group Differences
- IEC 62368-1

Electromagnetic compatibility

Emissions

- International: CISPR32: Class A
- Australia/New Zealand: AS/NZS CISPR 32: Class A
- Canada: ICES-003, Issue-4, Class A
- Europe: EN55032 2006 CISPR 32: Class A
- International: (CISPR 32), Class A
- EN55032
- Japan: VCCI V-3/2011.04, Class A
- Korea: KN32, Class A
- Taiwan: CNS13438, Class A
- USA: FCC CFR47 Part 15, Subpart B, Class A

Immunity

- EN 300 386 v2.1.1 (2016-07) for Network Equipment
- EN 55024 + A1 + A2
- EN 61000-3-2 Harmonic Current Emissions
- EN 61000-3-3 Voltage Fluctuations and Flicker
- EN 61000-4-2 ESD
- EN 61000-4-3 Radiated Immunity
- EN 61000-4-4 EFT
- EN 61000-4-5 Surge
- EN 61000-4-6 Low Frequency Conducted Immunity
- EN 61000-6-1

Product recycling and disposal

You must recycle or discard this switch according to applicable local and national regulations. Dell encourages owners of information technology (IT) equipment to responsibly recycle their equipment when it is no longer needed. Dell offers various product return programs and services in several countries to assist equipment owners in recycling their IT products.

Waste electrical and electronic equipment (WEEE) directive for recovery, recycle, and reuse of IT and telecommunications products

Dell switches are labeled in accordance with European Directive 2002/96/EC concerning waste electrical and electronic equipment (WEEE). The Directive determines the framework for the return and recycling of used appliances as applicable throughout the European Union. This label is applied to various products to indicate that the product is not to be thrown away, but rather reclaimed upon end of life per this Directive.



Figure 26. The European WEEE symbol

In accordance with the European WEEE Directive, electrical and electronic equipment (EEE) is to be collected separately and to be reused, recycled, or recovered at end of life. Users of EEE with the WEEE marking per Annex IV of the WEEE Directive, as shown above, must not dispose of end of life EEE as unsorted municipal waste, but use the collection framework available to customers for the return, recycling and recovery of WEEE. Customer participation is important to minimize any potential effects of EEE on the environment and human health due to the potential presence of hazardous substances in EEE.

Dell products, which fall within the scope of the WEEE, are labeled with the crossed-out wheeled-bin symbol, as shown above, as required by WEEE.

For information about Dell product recycling offerings, see the WEEE Recycling instructions on Support. For more information, contact the Dell Technical Assistance Center.

Dell support

The Dell support site provides documents and tools to help you effectively use Dell equipment and mitigate network outages. Through the support site you can obtain technical information, access software upgrades and patches, download available management software, and manage your open cases. The Dell support site provides integrated, secure access to these services.

To access the Dell support site, go to <https://www.dell.com/support/>. To display information in your language, scroll down to the bottom of the web page and select your country or region from the drop-down menu.

- To obtain product-specific information, enter the 7-character service tag, which is known as a luggage tag, or 11-digit express service code of your switch and click **Submit**.

To view the chassis service tag or express service code, pull out the tag or enter the `show chassis` command from the CLI.

- To receive more technical support, click **Contact Us**. On the Contact Information web page, click **Technical Support**.

To access switch documentation, go to <https://www.dell.com/manuals/>.

To search for drivers and downloads, go to <https://www.dell.com/drivers/>.

To participate in Dell community blogs and forums, go to <https://www.dell.com/community>.