

Dell EMC PowerSwitch S4048T-ON Installation Guide

March 2021

Notes, cautions, and warnings

 **NOTE:** A NOTE indicates important information that helps you make better use of your computer.

 **CAUTION:** A CAUTION indicates either potential damage to hardware or loss of data and tells you how to avoid the problem.

 **WARNING:** A WARNING indicates a potential for property damage, personal injury, or death.

Chapter 1: About this guide	5
Related documents.....	5
Chapter 2: The S4048T-ON System	6
Introduction.....	6
System status.....	7
LED display.....	7
LED behavior.....	7
Luggage tag.....	10
Prerequisites.....	10
S4048T-ON configurations.....	11
Chapter 3: Site preparations	12
Site selection.....	12
Cabinet placement.....	13
Rack mounting.....	13
System ground.....	13
Fans and airflow.....	13
Power.....	14
Storing components.....	14
Chapter 4: NEBS compliance	15
Important information.....	15
Chapter 5: S4048T-ON installation	16
Unpack the S4048T-ON system.....	16
Unpack.....	16
Ground lug and bracket installation.....	16
ReadyRails installation.....	18
1U tool-less configuration.....	18
Two-post flush-mount configuration.....	19
Two-post center-mount configuration.....	19
Four-post threaded configuration.....	20
1U two-post installation.....	21
Ground wire installation.....	21
Optic installation.....	22
Optic removal.....	23
Split ports.....	23
System power-up.....	23
Power up sequence.....	23
Before you install an OS.....	23
ONIE service discovery.....	24
Chapter 6: Power supplies	26

Components.....	26
AC power supply installation.....	27
AC power supply replacement.....	27
DC power supply connection.....	28
Chapter 7: Fans.....	29
Components.....	29
Fan module installation.....	30
Fan module replacement.....	30
Fan air filter replacement.....	30
Chapter 8: Management ports.....	32
RS-232 console port access.....	32
Micro USB-B console port access.....	33
USB storage mount.....	33
Chapter 9: Specifications.....	35
Chassis physical design.....	35
IEEE standards.....	36
Agency compliance.....	36
USA Federal Communications Commission Statement.....	36
European Union EMC Directive Conformance Statement.....	37
Japan VCCI Compliance for Class A Equipment.....	37
Korean Certification of Compliance.....	38
Safety Standards and Compliance Agency Certifications.....	38
Electromagnetic Compatibility	38
Product Recycling and Disposal.....	39
Chapter 10: Dell EMC support.....	40

About this guide

This guide provides site preparation recommendations, step-by-step procedures for rack mounting and desk mounting, inserting optional modules, and connecting to a power source.

CAUTION: To avoid electrostatic discharge (ESD) damage, wear grounding wrist straps when handling this equipment.

NOTE: Only trained and qualified personnel can install this equipment. Read this guide before you install and power up this equipment. This equipment contains two power cords. Disconnect both power cords before servicing.

NOTE: This equipment contains optical transceivers that comply with the limits of Class 1 laser radiation.



Figure 1. Class 1 laser product label

NOTE: When no cable is connected, visible and invisible laser radiation may be emitted from the aperture of the optical transceiver ports. Avoid exposure to laser radiation and do not stare into open apertures.

Topics:

- [Related documents](#)

Related documents

For more details about the S4048T-ON system, see the following documents:

- Dell Networking Release Notes for the S4048T-ON System*
- Dell Networking Configuration Guide for the S4048T-ON System*
- Dell Networking Command Line Reference Guide for the S4048T-ON System*
- Dell Open Networking Hardware Diagnostic Guide*

NOTE: For the most recent documentation, visit Dell EMC support: www.dell.com/support

The S4048T-ON System

The following sections describe the Dell EMC S4048T-ON system:

Topics:

- [Introduction](#)
- [System status](#)
- [LED display](#)
- [Luggage tag](#)
- [Prerequisites](#)
- [S4048T-ON configurations](#)

Introduction

The S4048T-ON is a networking switch for campus aggregation and core switching 10 Gbps servers and 40 Gbps optical uplinks to the 40 Gbps switching fabric in the core.

The S4048T-ON offers the following features:

- 48 fixed 10GBase-T ports supporting 1G/10G speeds
- Six fixed QSFP+ ports supporting either one port of 40G or four ports of 10G in breakout mode
- One Micro USB serial console port
- One universal serial bus (USB) type-A port for more file storage
- Dual core 1.7 GHz Rangeley central processing unit (CPU) system
- Temperature monitoring
- Software-readable thermal monitor
- Real time clock (RTC) support
- Two hot plug redundant power supplies
- Power management monitoring
- Four removable fans
- Standard 1U chassis

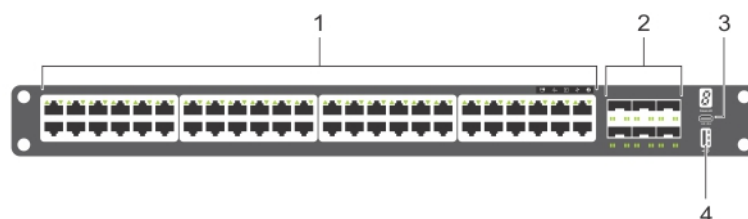

Figure 2. S4048T-ON I/O side view

1. 48 10GBase-T ports
2. 6 QSFP+ ports
3. Micro USB-B console port
4. USB-A port

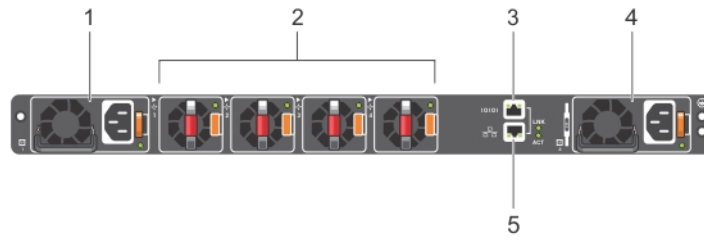

Figure 3. S4048T-ON PSU-side view

1. PSU1
2. Fan modules
3. RS-232/RJ-45 serial console port
4. PSU2
5. 10/100/1000BaseT Ethernet management port

System status

You can view system status information using the light emitting diodes (LEDs).

LED display

The S4048T-ON includes LED displays on both the I/O side and PSU side of the chassis.

For LED information, see your third-party operating software documentation.

LED behavior

The following system LED behavior is seen during open networking installation environment (ONIE) operations:

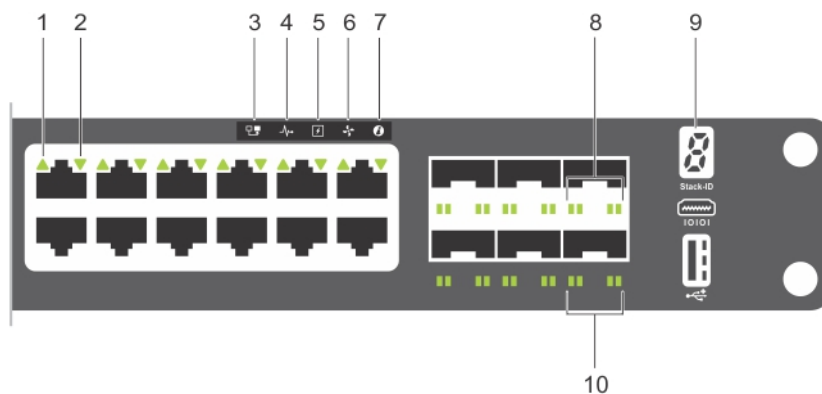

Figure 4. S4048T-ON I/O -side LEDs

1. 10 GBT—top row port
2. 10 GBT—bottom row port
3. Master LED
4. System LED
5. Power LED
6. Fan status LED

7. Locator LED
8. QSFP+ LED—top row port
9. Stack ID number
10. QSFP+ LED—bottom row port

Table 1. S4048T-ON I/O-side LED behavior

LED	Description
10 GBT	<ul style="list-style-type: none"> ● Off—no link ● Solid green—link at 10G speed ● Blinking green—port activity at 10G speed ● Solid amber—link at speed lower than 10G ● Blinking amber—port activity at lower than 10G speed ● Solid blue—port locator function
Master	<ul style="list-style-type: none"> ● Off—switch is in stacking slave mode ● Solid green—system is in stacking master or standalone mode
System	<ul style="list-style-type: none"> ● Solid green—normal operation ● Blinking green—booting ● Solid amber—critical system error ● Blinking amber—noncritical system error—fan failure or power supply failure
Power	<ul style="list-style-type: none"> ● Solid green—normal ● Solid amber—POST is in progress ● Blinking amber—power supply failed ● Off—no power
Fan	<ul style="list-style-type: none"> ● Solid green—fan powered and running at the expected RPM ● Blinking amber—fan failed, including incompatible airflow direction when you insert the PSU or fan trays with differing airflows
Locator	<ul style="list-style-type: none"> ● Off—locator function is disabled ● Blinking blue—locator function is enabled
QSFP+ port when used as one 40G port—only first LED is used in 40G mode	<ul style="list-style-type: none"> ● Off—No Link ● Solid green—link at 40G speed ● Blinking green—port activity at 40G speed ● Solid amber—link at speed lower than 40G ● Blinking amber—port activity at lower than 40G speed ● Blinking amber one second on/one second off—port locator function
QSFP+ port when used as four ports of 10G—all four LEDs are used	<ul style="list-style-type: none"> ● Off—no Link ● Solid amber—4x10G speed ● Blinking amber—port activity at 4x10G speed ● Blinking amber one second on/one second off—port locator function
Stack ID Number	<p>Displays the stack unit number of the switch</p> <p>Displays 1 by default if switch is not part of a stack</p>

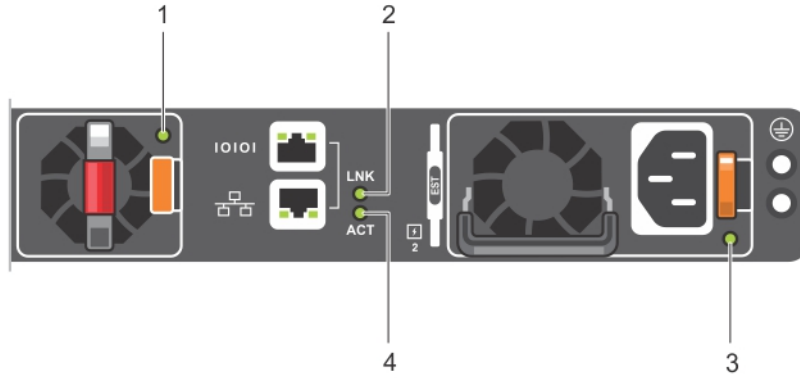

Figure 5. S4048T-ON PSU-side LEDs

1. Fan LED
2. Management port link LED
3. PSU LED
4. Management port act LED

Table 2. S4048T-ON PSU-side LED behavior

LED	Description
Fan LED	<ul style="list-style-type: none"> • Off—no power to fan/failure • Solid Green—fan is operating normally • Solid Amber—fan failure
Management port Link LED	<ul style="list-style-type: none"> • Off—no link • Solid green—link on 1G speed • Solid amber—link on 10/100 Mbps speeds
Management port Activity LED	<ul style="list-style-type: none"> • Off—no link • Blinking green—transmit/receive is active
PSU LED	<ul style="list-style-type: none"> • Off—no power to PSU/failure • Solid Green—PSU is operating normally • Blinking Green—PSU is turned off

Luggage tag

The S4048T-ON system has a pull-out tag, known as a luggage tag, on the same side as the PSUs.

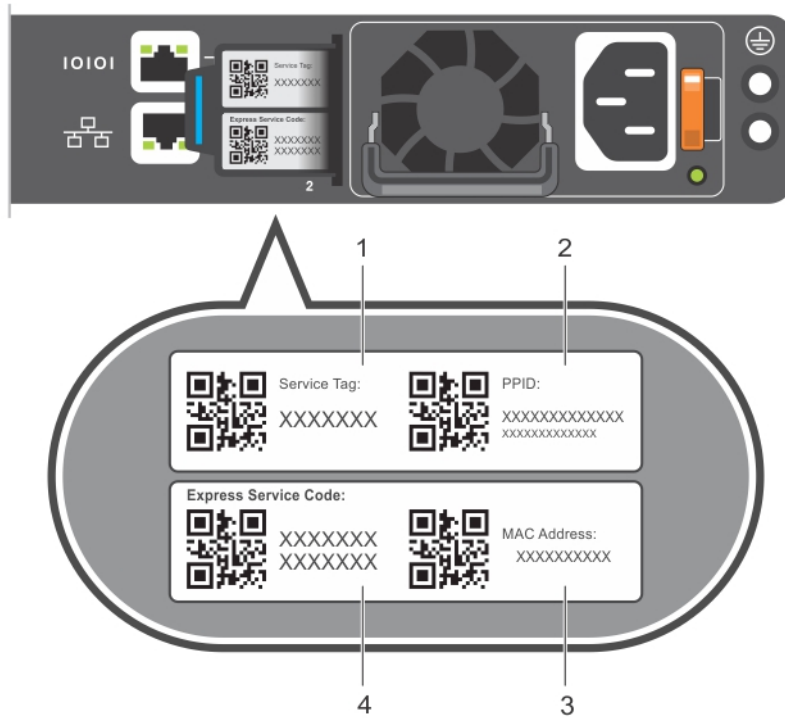

Figure 6. S4048T-ON luggage tag

- 1. Service tag
- 2. PPID
- 3. MAC address
- 4. Express service code

Prerequisites

The following is a list of system components:

NOTE: For more information, see [Site Preparations](#) and [S4048T-ON Installation](#).

- S4048T-ON chassis or multiple chassis, if stacking
- AC or DC country/regional specific power cables to connect the AC or DC power source to each of the chassis' AC or DC power supplies
- ReadyRail™ mounting brackets for rack installation
- Screws for rack installation
- Grounding GND lug, L-bracket, screws for the chassis

Items that are not included:

- GND lug and screws for the rack
- Ground wire
- Crimping tool
- Antioxidant compound—Dell EMC recommends NOALOX 4 or equivalent
- Thread-locker compound—Dell EMC recommends Threadlocker Blue 242 or equivalent
- #1 and #2 Phillips screwdrivers
- Torx screwdriver
- Copper/fiber cables

Other optional components are:

- Extra fan module, recommended for redundancy
- Extra mounting brackets if installing in a four-post rack or cabinet

S4048T-ON configurations

You can order the S4048T-ON system in several different configurations. Optional modules and optics are available to order separately.

You can order the following supported hardware components:

- S4048T-ON AC or DC Normal Airflow: 48-port 10GBase-T ports with six QSFP+ 40 G ports, two AC power supply units and four fan subsystems—airflow from the I/O side to the PSU side
- S4048T-ON AC or DC Reverse Airflow: 48-port 10GBase-T ports with six QSFP+ 40 G ports, two AC power supply units and four fan subsystems—airflow from the PSU side to the I/O side
- Fan with airflow from the I/O side to the PSU side
- Fan with airflow from the PSU side to the I/O side
- AC or DC power supply with airflow from the I/O side to the PSU side
- AC or DC power supply with airflow from the PSU side to the I/O side

Site preparations

The S4048T-ON is suitable for installation as part of a common bond network (CBN).

You can install the system in:

- Network telecommunication facilities
- Data centers
- Other locations where the National Electric Code (NEC) applies

For more information about S4048T-ON specifications, see [Specifications](#).

 **NOTE:** Install the S4048T-ON system into a rack or cabinet before installing any optional components.

Topics:

- [Site selection](#)
- [Cabinet placement](#)
- [Rack mounting](#)
- [System ground](#)
- [Fans and airflow](#)
- [Power](#)
- [Storing components](#)

Site selection

Install Dell EMC equipment in restricted access areas.

A restricted access area is one in which service personnel can only gain access using a special tool, lock, key or other means of security. Only the authority responsible for the location can grant access to the restricted access area.

 **CAUTION:** Your switch is not NEBS Earthquake Z4-compliant if you use the 1U tool-less square-hole or two-post installation methods.

 **CAUTION:** Only trained and qualified personnel should install this equipment. Read this guide before installing and powering up the system.

 **WARNING:** The following information is a condensed reference. Read the safety instructions in your Safety, Environmental, and Regulatory information booklet before you begin.

Ensure that the area where you install your system meets the following safety requirements:

- Near an adequate power source. Connect the switch to the appropriate branch circuit protection according to your local electrical codes.
- Environmental temperature between 32° to 113°F (from 0° to 45°C).
- The switch operating ambient temperature range is from 0° to 45°C (from 32° to 113°F).
- Relative humidity is from 5 to 90 percent noncondensing.
- In a dry, clean, well-ventilated and temperature-controlled room, away from heat sources such as hot air ventilation outlets or direct sunlight.
- Away from sources of severe electromagnetic noise.
- Inside the restricted access area, positioned in a rack or cabinet, or on a desktop with adequate space in the front, back, and sides for proper ventilation and access.
- Install the switch in Information Technology Rooms in accordance with Article 645 of the National Electrical Code and NFPA 75.

For more information about switch storage and environmental temperatures, see [Specifications](#).

Review these guidelines for rack mounting:

- Rack mounting—You may either place the switch on a rack shelf or mount the switch directly into a 19" wide, EIA-310-E-compliant rack.
- Rack loading—Overloading or uneven loading of racks may result in shelf or rack failure and may damage the equipment or cause possible personal injury. Stabilize the racks in a permanent location before loading begins. Mount the components starting at the bottom of the rack, then work to the top. Do not exceed your rack load rating.
- Power considerations—Connect only to the power source specified on the unit. When you install multiple electrical components in a rack, ensure that the total component power ratings do not exceed the circuit capabilities. Overloaded power sources and extension cords present fire and shock hazards.
- Elevated ambient temperature—If you install the equipment in a closed rack assembly, the operating temperature of the rack environment may be greater than the room ambient temperature. The acceptable ambient temperature ranges are listed in [Specifications](#) under Environmental Parameters.
- Reduced air flow—Install the equipment in the rack so that you do not compromise the amount of airflow required for safe operation of the switch. For proper ventilation, position the chassis in an equipment rack or cabinet with a minimum of 5 inches (12.7 cm) of clearance around exhaust vents.
- Reverse air flow—To ensure cool air intake and to avoid hot air blow out from the I/O side, ensure that you have the necessary clearance.
- Reliable earthing—Maintain reliable earthing of rack-mounted equipment. Pay particular attention to the supply connections other than the direct connections to the branch circuit; for example, use of power strips.
- Do not mount the equipment with the PSU side facing in a downward position.

i **NOTE:** Always handle the system and its components with care. Avoid dropping the chassis or its field replaceable units.

△ CAUTION: Always wear an electrostatic discharge (ESD) wrist or heel ground strap when handling a system and its components. As with all electrical devices of this type, take all necessary safety precautions to prevent injury when installing this system. ESD damage can occur if components are mishandled.

Cabinet placement

Install the S4048T-ON only in indoor cabinets designed for use in a controlled environment.

Do not install the S4048T-ON in outside cabinets. For cabinet placement requirements, see [Site selection](#).

The cabinet must meet minimum size requirements. Airflow must be in accordance with the Electronic Industries Alliance (EIA) standard. Ensure that there is a minimum of 5 inches (12.7 cm) between the intake and exhaust vents and the cabinet wall.

Rack mounting

When you prepare your equipment rack, ensure that the rack is grounded.

Ground the equipment rack to the same ground point the power service in your area uses. The ground path must be permanent.

System ground

Dell EMC recommends you ground your system. Use the S4048T-ON in a common bond network (CBN).

Connect the grounding cable as described in [Ground lug and bracket installation](#) and [Ground wire installation](#).

Fans and airflow

The S4048T-ON fans support two airflow options.

Fan combinations

Fans are installed as part of the factory install based on SKU type. The system has stock keeping units (SKUs) that support the following configurations:

- AC or DC PSU with fan airflow from the I/O to the PSU

- AC or DC PSU with fan airflow from the PSU to the I/O

Be sure to order the fans suitable to support your site's ventilation. Use a single type of airflow fan in your system.

 **NOTE:** *DO NOT* mix reverse and normal airflows in a single S4048T-ON chassis.

For proper ventilation, position the system in an equipment rack or cabinet with a minimum of 5 inches (12.7 cm) of clearance around the exhaust vents. When you install two systems near each other, position the two chassis at least 5 inches (12.7 cm) apart to permit proper airflow. The fan speed increases when the internal temperature reaches 132.8°F (56°C) and decreases to normal speed when the temperature falls to 127.4°F (53°C). The S4048T-ON never intentionally turns off the fans.

Power

To connect the chassis to the applicable power source, use the appropriate power cord.

- If the switch is an AC model, a country/region-specific AC power cord is included with each PSU.
- If the switch is a DC model, a country/region-specific DC power cord is included with each DC power kit.

When installing AC systems, follow the requirements of the National Electrical Code, ANSI/NFPA 70 where applicable.

The system is powered-up when the power cord is connected between the system and the power source.

 **CAUTION:** Always disconnect the power cable before you service the power supply slots.

 **CAUTION:** Use the power supply cord as the main disconnect device on the AC system. Ensure that the socket-outlet is located/installed near the equipment and is easily accessible.

Storing components

If you do not install your system and components immediately, Dell EMC recommends properly storing the system and all optional components by following these guidelines:

- Storage location temperature must remain constant ranging from -40° to 158°F (from -40°C to 70°C).
- Store on a dry surface or floor, away from direct sunlight, heat, and air conditioning ducts.
- Store in a dust-free environment.

 **NOTE:** ESD damage can occur when components are mishandled. Always wear an ESD-preventive wrist or heel ground strap when handling the S4048T-ON and its accessories. After you remove the original packaging, place the S4048T-ON and its components on an antistatic surface.

NEBS compliance

For your system to be network equipment building system (NEBS) compliant, you must follow the instructions detailed in this chapter.

To be NEBS compliant, orient your system in the rack so that the air inlet is from the front aisle and the air exhaust is from the rear aisle.

Topics:

- [Important information](#)

Important information

⚠ WARNING: The quad form-factor pluggable (QSFP), BaseT, console, Ethernet management, and universal serial bus (USB) ports are suitable for connection to intra-building or unexposed wiring or cabling only. You **MUST NOT** metallically connect the ports to interfaces that connect to the out side plant (OSP) or its wiring. Use these interfaces as intra-building interfaces only—Type 2 or Type 4 ports as described in GR-1089-CORE, Issue 6. Also, they require isolation from the exposed OSP cabling. Adding primary protectors is not sufficient protection to connect these interfaces metallically to OSP wiring.

⚠ WARNING: If you install and connect the S4048T-ON to a commercial AC power source, you must connect the system to an external special protection device (SPD).

⚠ WARNING: Use shielded intra-building cabling that is grounded at both ends for the 1/10GbE BaseT intra-building ports.

To be NEBS compliant, follow these regulations:

- Locate your system in a restricted-access area where only trained personnel are allowed access.
- Install and connect your system to the common bonding network (CBN).
- You can also install and connect your system to the central office.
- Connect the battery returns of your system as DC-I.
- Ground your system using a copper ground conductor.
- Clean and coat all bare grounding connection points on your system with an anti-oxidant solution before making connections.
- Bring all unplated surfaces on your system to a bright finish and treat them with an anti-oxidant solution before making connections.
- Remove any non-conductive surfaces on your system from the threads and connection points to ensure electrical continuity.
- Use the two-hole, Listed, compression-type lug with an AWG 14 gauge wire that uses 4-in/lb to secure your system to the frame.

i NOTE: The S4048T-ON can operate at -40.5 to -60 VDC at a maximum current level of 24A or at 100–240 VAC at a maximum current level of 7.1A.

i NOTE: The S4048T-ON is Earthquake Z4-compliant when you attach the ReadyRails to the frame using threaded hardware. Do not use the tool-less or two-post installation methods.

S4048T-ON installation

To install the S4048T-ON system, Dell EMC recommends completing the installation procedures in the order presented in this guide.

Always handle the S4048T-ON and its components with care. Avoid dropping the system or its field replaceable units (FRUs).

i **NOTE:** ESD damage can occur if components are mishandled. Always wear an ESD-preventive wrist or heel ground strap when handling the S4048T-ON and its components. As with all electrical devices of this type, take all the necessary safety precautions to prevent injury when installing this system.

Topics:

- [Unpack the S4048T-ON system](#)
- [Ground lug and bracket installation](#)
- [ReadyRails installation](#)
- [Ground wire installation](#)
- [Optic installation](#)
- [System power-up](#)
- [Before you install an OS](#)

Unpack the S4048T-ON system

i **NOTE:** Before unpacking the system, inspect the container and immediately report any evidence of damage.

When unpacking system, make sure that the following items are included:

- One S4048T-ON switch
- One RJ-45 to DB-9 female cable
- One ReadyRails™ kit for rack installation, two mounting brackets, bolts, and cage nuts
- One grounding GND lug, L-bracket, and screws for chassis
- One set of self-adhesive rubber pads for free-standing installation, four pads are included
- Two PSUs
- Two AC country/region-specific power cords
- *Getting Started Guide*
- *Safety and Regulatory Information*
- *Warranty and Support Information*

Unpack

1. Place the container on a clean, flat surface and cut all straps securing the container.
2. Open the container, or remove the container top.
3. Remove the switch from the container carefully. Place it on a secure and clean surface.
4. Remove all packing material.
5. Inspect the product and accessories for damage.

Ground lug and bracket installation

Before you install the system in a rack, install the ground (GND) lug and bracket assembly with a ground wire attached.

Dell EMC supplies a kit with the following:

- One 2-hole UL-certified GND lug
- L-bracket
- Two flat head screws to attach the lug to the bracket
- Two pan head screws to attach the assembly to the chassis

Supply the following:

- A wire that complies with your local electrical codes in size and color. The wire is typically 14 AWG colored green or green with a yellow stripe
- An antioxidant compound—Dell EMC recommends NOALOX 4 or equivalent
- A crimping tool
- A thread-locker compound—Dell EMC recommends Threadlocker Blue 242 or equivalent

1. Attach the end of the ground wire to the GND lug:
 - a. Coat the bare end of the wire with an antioxidant compound.
 - b. Insert the end of the wire into the lug.
 - c. To secure the connect of the wire to the lug, crimp the lug end.

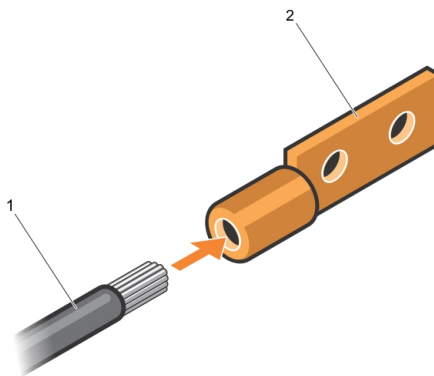

Figure 7. Ground wire and GND lug

- a. 1—Ground wire
- b. 2—GND lug

2. Apply the thread-locker compound to the two flat head screws, then attach the GND lug to the L-bracket.

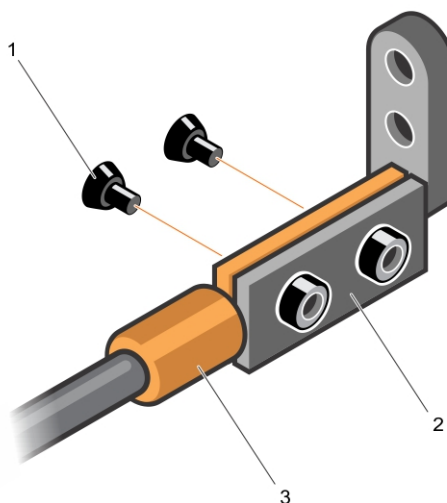

Figure 8. Screws, GND lug, and L-bracket assembly

- a. 1—Flat head screws

- b. 2—GND lug
 - c. 3—Attached ground wire
3. Attach the assembly to the S4048T-ON chassis:
- a. Apply the thread-locker compound to the two pan head screws.
 - b. Attach the GND lug and bracket assembly to the two-hole chassis ground connector nuts on the PSU side. Tighten the screws to ensure torque between 3–5 inch/lbs.

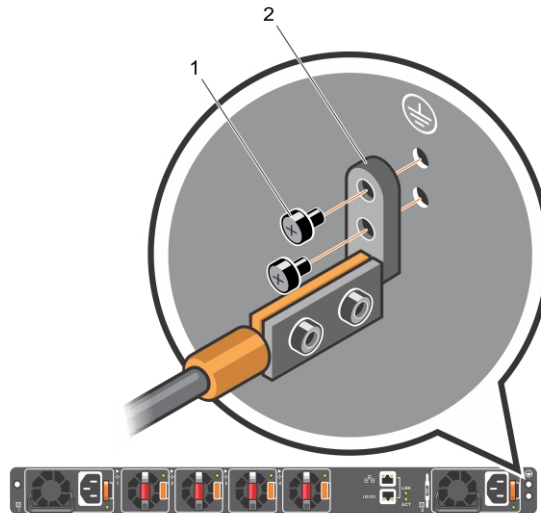

Figure 9. S4048T-ON PSU-side ground

- a. 1—Pan head screws
- b. 2—L-bracket

CAUTION: Take care not to damage the attached ground wire as you proceed to install the switch.

After you install the switch in the rack, see [Ground wire installation](#).

ReadyRails installation

Use the ReadyRails™ rack mounting system to easily configure your rack so that you can install your switch.

The ReadyRails system is provided for 1U front-rack and two-post installations. The ReadyRails system includes two separately packaged rail assemblies and two rails that are shipped attached to the sides of the switch. Install the ReadyRails system using the 1U tool-less method or one of three possible 1U tooled methods—two-post flush mount, two-post center mount, or four-post threaded.

CAUTION: Your system is not NEBS Earthquake Z4-compliant if you use the 1U tool-less square-hole or two-post installation methods.

CAUTION: Do not use the mounted ReadyRails as a shelf or a workplace.

NOTE: The illustrations in this document are not intended to represent a specific switch.

1U tool-less configuration

NOTE: Your system is not NEBS Earthquake Z4-compliant if you use this method.

1. Face the ReadyRails flange ears outward, place one rail between the left and right vertical posts.

Align and seat the back flange rail pegs in the back vertical post flange. This illustration shows how the pegs appear in both the square and unthreaded round holes.

2. Align and seat the front flange pegs in the holes on the front side of the vertical post.
3. Repeat this procedure for the second rail.
4. To remove each rail, pull on the latch release button on each flange ear and unseat each rail.

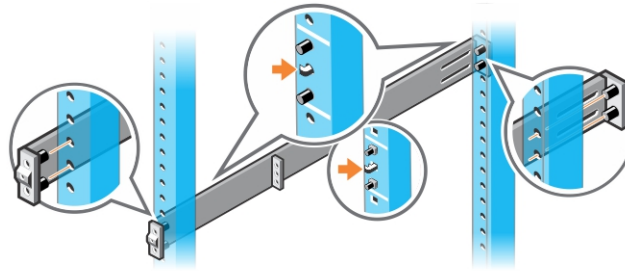

Figure 10. 1U tool-less configuration

Two-post flush-mount configuration

CAUTION: Your system is not NEBS Earthquake Z4-compliant if you use this installation method.

1. Remove the tool-less latch castings from the front side of each ReadyRails assembly, item 1.
Use a Torx driver to remove the two screws from each front flange ear on the switch side of the rail. Remove each latch casting. Retain the castings for future rack requirements. It is not necessary to remove the rear flange castings.
2. Attach one rail to the front post flange with two user-supplied screws, item 2.
3. Slide the plunger bracket forward against the vertical post and secure the plunger bracket to the post flange with two user-supplied screws, item 3.
4. Repeat this procedure for the second rail.

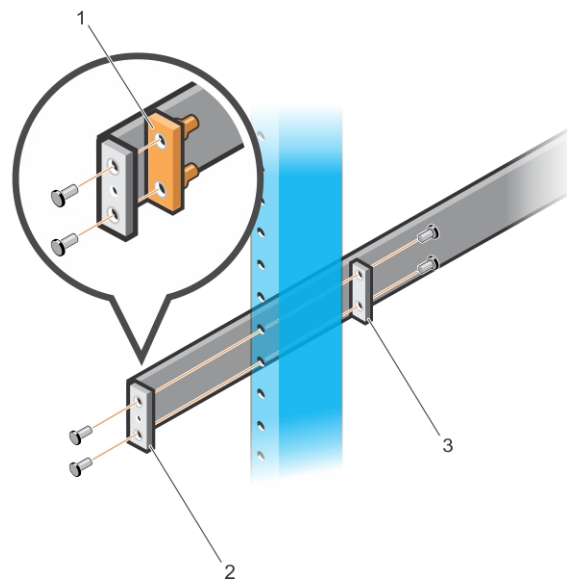

Figure 11. Two-post flush-mount configuration

Two-post center-mount configuration

CAUTION: Your system is not NEBS Earthquake Z4-compliant if you use this installation method.

1. Slide the plunger bracket rearward until it clicks into place and secure the bracket to the front post flange with two user-supplied screws, item 1.
2. Slide the back bracket towards the post and secure it to the post flange with two user-supplied screws, item 2.
3. Repeat this procedure for the second rail.

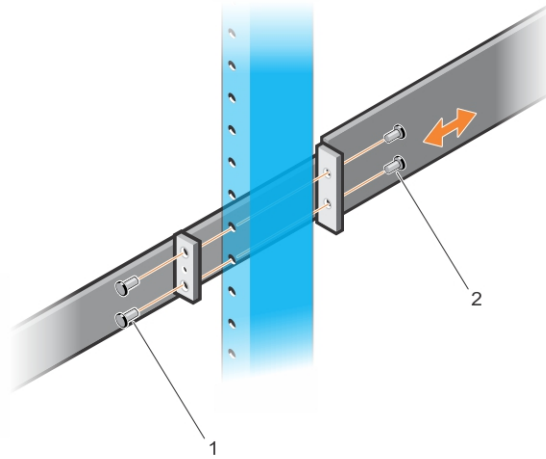

Figure 12. Two-post center-mount configuration

Four-post threaded configuration

CAUTION: To be NEBS Earthquake Z4-compliant, you must remove the tool-less latch castings described in Step 1.

1. Remove the tool-less latch castings from each end of the ReadyRails assemblies.
Use a Torx driver to remove the two screws from each latch casting. Remove each casting, item 1. Retain the castings for future rack requirements.
2. Attach the front and rear flanges for each rail to the post flanges with two user-supplied screws at each end, item 2.

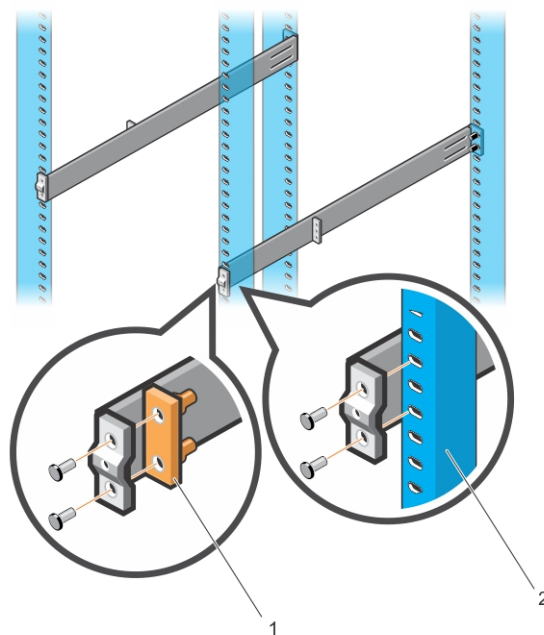

Figure 13. Four-post threaded configuration

1U two-post installation

You can install the switch in 1U front-rack, four-post or two-post configurations. The following is an example of a front-rack configuration.

For the 1U two-post flush or center configurations, slide the system into the rails in the same manner as the four-post configurations.

1U front-rack installation

Configure the rails that are attached to the system:

1. Attach the inner chassis members switch rails to the system, items 1 and 2.
The following illustration, item 3, shows the detail for the front standoff with the locking tab.

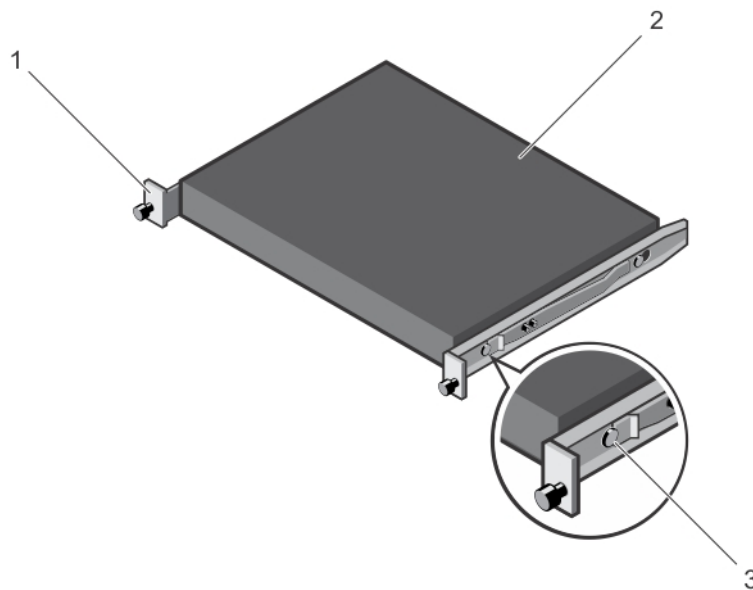

Figure 14. Switch rail attachment

2. After you have installed both switch rails, line them up on the previously mounted Ready-Rails and slide the switch in until it is flush with front of rack.
About three inches prior to full insertion, the rail locking feature engages to keep the switch from inadvertently sliding out of the rack and falling.

NOTE: Do not use the mounted Ready-Rails as a shelf or a workplace.

Ground wire installation

After you have installed the S4048T-ON switch in a rack, complete the installation of the ground wire.

You previously installed the GND lug and bracket assembly, with ground wire attached, to the S4048T-ON chassis, see [Ground lug and bracket installation](#).

Provide the following items:

- One 2-hole UL-certified GND lug to attach ground wire to rack
- Two National Electric Code (NEC) compliant screws to attach the GND lug to the rack
- Antioxidant compound
- Crimping tool

1. Measure and cut a length of wire sufficient to reach between the system-installed GND lug and the rack-end GND lug.

2. Attach the end of the wire to the rack-end GND lug.
 - a. Coat the bare end of the wire with an antioxidant compound.
 - b. Insert the end of the wire into the lug.
 - c. To secure the connection, crimp the lug end.

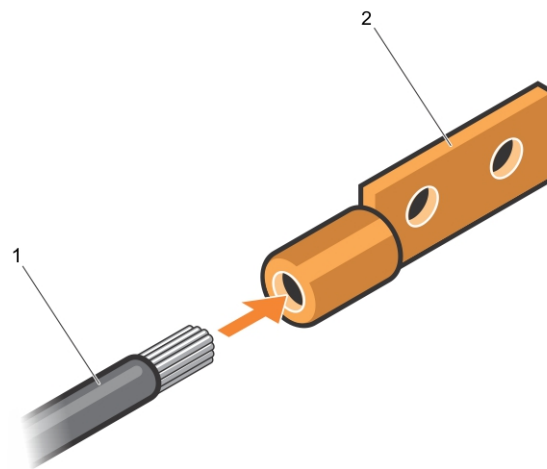

Figure 15. Ground wire and GND lug

- a. 1—Ground wire
 - b. 2—GND lug
3. Install the second GND lug, in compliance with NEC guidelines, at the desired location to ground the switch.
 - a. Ensure that the rack mating surface is clean.
 - b. Bring any bare metal to a bright finish.
 - c. Apply the antioxidant compound to the mating surfaces before mating.

Optic installation

The S4048T-ON system has 48 RJ-45 ports and six quad small form-factor pluggable plus (QSFP+) optical ports.

For a list of supported optics, see the S4048T-ON Specification Sheet at www.dell.com/support/ or contact your Dell EMC Networking representative.

CAUTION: ESD damage can occur if the components are mishandled. Always wear an ESD-preventive wrist or heel ground strap when handling the system and its components.

NOTE: When working with optical fibers, follow all the warning labels and always wear eye protection. Never look directly into the end of a terminated or unterminated fiber or connector as it may cause eye damage.

1. Position the optic so it is in the correct position.

The optic has a key that prevents it from being inserted incorrectly.

2. Insert the optic into the port until it gently snaps into place.

NOTE: Both rows of QSFP+ ports require that you install the 40 GbE optics with the tabs facing up.

NOTE: When you cable the ports, do not block the airflow from the small ventilation holes over and below the ports.

Optic removal

Remove an optic by pushing the tab on the optic and sliding the optic from the port.

When removing optics with direct attach cables (DACs) from the port, pull the release tab firmly and steadily. Before pulling the release tab, you may need to gently push the optic into the port to ensure it is seated properly. Do not jerk or tug repeatedly on the tab.

Split ports

The S4048T-ON supports splitting a single 40G QSFP+ port into four 10G ports using one of the supported breakout cables.

System power-up

Supply power to the S4048T-ON after it is mounted in a rack or cabinet.

Dell EMC recommends reinspecting your system before powering up. Verify the following:

- The equipment is properly secured to the rack and properly grounded, optional.
- The equipment rack is properly mounted and grounded, optional.
- The ambient temperature around the unit, which may be higher than the room temperature, is within the limits specified for the S4048T-ON, see [Specifications](#).
- There is sufficient airflow around the unit.
- The input circuits are correctly sized for the loads and that you use sufficient overcurrent protection devices.
- All protective covers are in place.
- Blank panels are installed if you do not install optional modules.

i **NOTE:** A US AC power cable is included for powering up an AC power supply. You must order all other power cables separately.

i **NOTE:** ESD damage can occur if components are mishandled. Always wear an ESD-preventive wrist or heel ground strap when handling the S4048T-ON system and its components.

Power up sequence

When the system powers up, the fans immediately come on at high speed. The fan speed slows as the system boots up.

Before you install an OS

After powering on the S4048T-ON system, it goes through a power-on self-test (POST).

POST runs every time the switch initializes and checks hardware components to determine if the switch is fully operational before booting. After POST, the system uses the Grub bootloader.

Use the up and down arrow keys to select which entry is selected. To edit the commands before booting, press **Enter** to select an OS or enter **e**. Enter **c** for a command line. The selected entry runs automatically in the operating system.

Grub bootloader example

```
GNU GRUB  version 2.02~beta2+e4a1fe391
+-----+
|*ONIE: Install OS          |
| ONIE: Rescue              |
| ONIE: Uninstall OS       |
| ONIE: Update ONIE        |
| ONIE: Embed ONIE         |
| ONIE: Diag ONIE          |
|                           |
```

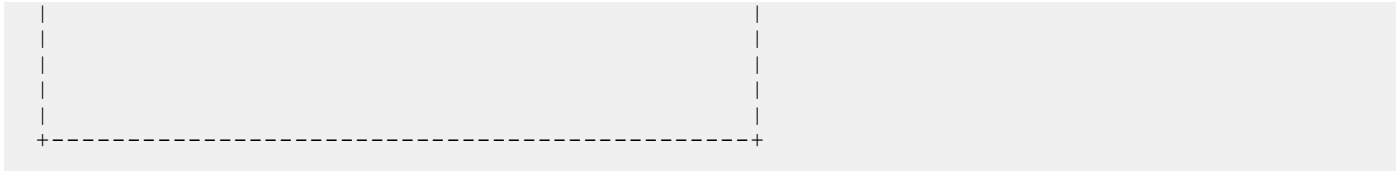

Your system comes with ONIE installed.

ONIE example

```
ONIE: Install OS
  For downloading and installing an OS from a URL
  Starts ONIE with ONIE Discovery Service
  (factory default boot)
ONIE: Rescue
  Starts ONIE without ONIE Discovery Service
  Useful for running Diagnostics manually
ONIE: Uninstall OS
  Restore to factory defaults erases any installed OS
ONIE: Update ONIE
  For downloading and updating ONIE from a URL
ONIE: Embed ONIE
  For downloading and updating ONIE from a URL and erases any installed OS
ONIE: Diag ONIE
  Run Diagnostic package for S4048T-ON
```

During initial setup, the system boots to ONIE Install. ONIE Install boots with ONIE Discovery to the console, `ONIE:.`

To configure your system, see your third-party ONIE-compatible OS or Dell EMC OS documentation.

ONIE service discovery

ONIE attempts to locate the installer through several discovery methods, as shown. To download and run an installer, the ONIE Service Discovery feature uses the first successful method found.

1. Pass from the boot loader.
2. Search locally attached storage devices for one of the ONIE default installer filenames; for example, USB.
3. Exact URLs from DHCPv4.
4. Inexact URLs based on DHCPv4 responses.
5. Query to IPv6 link-local neighbors using HTTP for an installer.
6. TFTP waterfall—from DHCPv4 option 66

If none of the ONIE Service Discovery methods are successful, you can disable this using the `onie-discovery-stop` command.

You can install an operating system manually from HTTP, FTP, or TFTP using the `onie-nos-install <URL>` command.

The ONIE Install environment uses DHCP to assign an IP address to the management interface, `eth0`. If that fails, it uses the default IP address `192.168.3.10/255.255.255.0`.

To display the IP address, use the `ifconfig eth0` command.

The following is an example of the `ifconfig eth0` command.

```
ONIE:/ # ifconfig eth0
eth0 Link encap:Ethernet HWaddr 90:B1:1C:F4:9C:76
      inet addr:10.11.53.33 Bcast:10.255.255.255 Mask:255.0.0.0
      inet6 addr: fe80::92b1:1cff:fef4:9c76/64 Scope:Link
      UP BROADCAST RUNNING MULTICAST MTU:1500 Metric:1
      RX packets:18 errors:0 dropped:0 overruns:0 frame:0
      TX packets:24 errors:0 dropped:0 overruns:0 carrier:0 collisions:0 txqueuelen:1000
      RX bytes:1152 (1.1 KiB) TX bytes:6864 (6.7 KiB)
      Interrupt:21 Memory:ff300000-ff320000
```

To assign an IP address to the management interface, eth0, and verify the network connectivity, use the `ifconfig eth0 <ip address>` command, as shown.

```
ONIE:/ # ifconfig eth0 10.11.53.33/16

Verify the network connection with ping.
ONIE:/ # ping 10.11.8.12
PING 10.11.8.12 (10.11.8.12): 56 data bytes
64 bytes from 10.11.8.12: seq=0 ttl=62 time=1.357 ms
64 bytes from 10.11.8.12: seq=1 ttl=62 time=0.577 ms
^C
```

Power supplies

The S4048T-ON ships with two power supply units.

The system supports AC or DC power supplies with two air-flow directions—from the I/O side to the PSU side and from the PSU side to the I/O side. Two PSUs are required for full redundancy, but the system can operate with a single PSU.

The PSUs are field replaceable. When running with full redundancy—two power supply units installed and running, you can remove and replace one PSU without disrupting traffic.

NOTE: If you use a single PSU, install a blank plate in the other PSU slot. Dell EMC recommends using PSU2 as the blank plate slot.

NOTE: Connect the power supply to the appropriate branch circuit protection as defined by your local electrical codes. Verify that the remote power source complies with the switch input power specifications.

NOTE: ESD damage can occur if components are mishandled. Always wear an ESD-preventive wrist or heel ground strap when handling the S4048T-ON and its components.

CAUTION: To prevent electrical shock, verify that the S4048T-ON is grounded properly. If you do not ground your equipment correctly, excessive emissions may result. Use a qualified electrician to ensure that the power cables meet your local electrical requirements.

Topics:

- [Components](#)
- [AC power supply installation](#)
- [DC power supply connection](#)

Components

The following power supply options are available for the S4048T-ON:

- AC or DC power supply with integrated fan
- AC or DC power supply with integrated reverse flow fan

PSU1 is on the left side of the chassis; PSU2 is on the right side of the chassis.

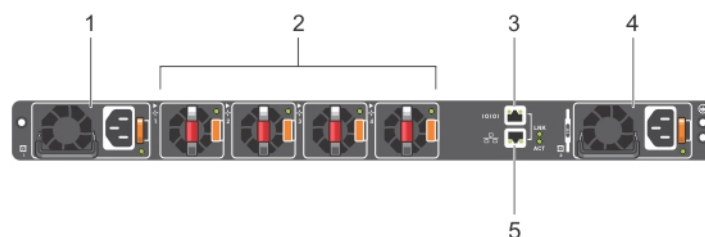

Figure 16. S4048T-ON PSU-side view

- | | |
|--|----------------|
| 1. PSU1 | 2. Fan modules |
| 3. RS-232/RJ-45 serial console port | 4. PSU2 |
| 5. 10/100/1000BaseT Ethernet management port | |

The PSUs are single units that include an integrated fan. You can individually replace the separate fan units however if the integrated PSU fan fails, you must replace the entire PSU. For fan tray replacement procedures, see [Fans](#).

⚠ WARNING: Prevent exposure and contact with hazardous voltages. Do not attempt to operate this system with the safety cover removed.

⚠ CAUTION: Remove the power cable from the PSU before removing the PSU. Also, do not connect the power cable before you insert the PSU in the chassis.

i NOTE: To comply with the GR-1089 Lightning Criteria for Equipment Interfacing with AC or DC Power Ports, use an external surge protection device (SPD) at the AC or DC input of the switch.

AC power supply installation

i NOTE: The PSU slides into the slot smoothly. Do not force a PSU into a slot as this action can damage the PSU or the chassis.

i NOTE: Ensure that you correctly install the PSU. When you install the PSU correctly, the power connector is on the right side of the PSU.

i NOTE: When using a single PSU, install a blank plate in the other PSU slot. If you are only using one power supply, Dell EMC recommends installing the power supply in the first slot, PSU1, and installing a blank plate in the second slot, PSU2.

1. Remove the PSU slot cover from the S4048T-ON system.

2. Remove the PSU from the electro-static bag.

3. Insert the PSU into the switch PSU slot.

Insert the PSU exposed PCB edge connector first.

The PSU slot is keyed so that you can only insert the PSU in one orientation.

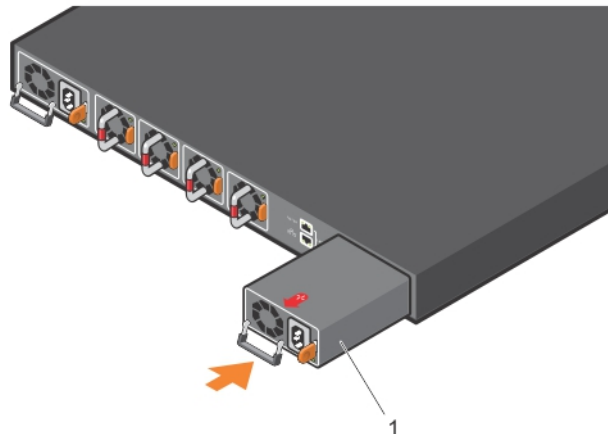

Figure 17. PSU installation

a. PSU

When you install the PSU correctly, it snaps into place and is flushed with the back of the switch.

4. Plug in the appropriate three-pronged AC cord from the switch PSU to the external power source.

5. If you have a redundant PSU, a second PSU, repeat steps 1 through 4 using the second PSU slot.

i NOTE: The S4048T-ON powers up when you connect the cables between the power supply and the power source.

AC power supply replacement

⚠ CAUTION: Disconnect the power cord before removing the power supplies. Also, disconnect all power cords before servicing.

- NOTE:** The PSU slides into the slot smoothly. Do not force a PSU into a slot as this action may damage the PSU or the S4048T–ON chassis.
 - NOTE:** If a PSU fails, you must replace the entire unit. There are no field serviceable components in the PSU. To request a hardware replacement, see [Dell Support](#).
 - NOTE:** If you use a single PSU, install a blank plate in the other PSU slot. If you are only using one power supply, Dell EMC recommends installing the power supply in the first slot, PSU1, and installing a blank plate in the second slot, PSU2.
1. Disconnect the power cable from the PSU.
 2. Use the grab handle to slide the PSU out of the power supply bay.
 3. Use the grab handle on the replacement PSU to slide it into the power supply bay.
 4. Attach the power cord to the replacement PSU.
- NOTE:** The system powers up when you connect the cables between the power supply and the power source.

DC power supply connection

Each DC PSU kit, sold separately, comes with a connector cable.

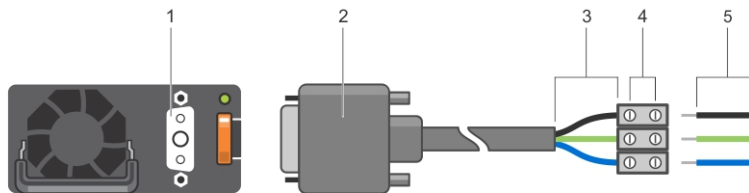

Figure 18. DC power supply and connector cable

1. DC PSU power socket
 2. Cable connector with thumb screws
 3. Cable connector wires—black, green, and blue
 4. Wiring block
 5. DC power source wires—black, green, blue
1. Strip 1/2 inches of insulation from each of the site's DC power source wires, item 5.
 2. Insert each of the site's DC power source's bare wire lengths into the wiring block, matching the wire colors, items 3 and 4.
 - WARNING:** Do not cross the wires—in the wiring block, blue aligns with blue, green aligns with green, and black aligns with black.
 3. Use a flat-blade screwdriver to tighten the screws that secure the bare wires into the wiring block.
 4. Insert the DC power connector cable end into the power socket of the DC PSU and tighten the thumb screws, items 1 and 2.
 - WARNING:** Never force the power connector into or out of the DC PSU power socket.
- NOTE:** To remove the power connector from a DC PSU, unscrew the thumb screws and pull the power connector from the DC PSU socket.

Fans

The S4048T-ON comes from the factory with two PSUs and four fan modules installed in the chassis. The fan modules and the power supplies, which have integrated fans, are hot-swappable.

NOTE: To run the system, the four fan slots must have operating fan units. If you do not install a module in each slot, the system shuts down in one minute.

In addition to the power supply modules, you can order and install fan modules separately.

The system supports two airflow direction options. *DO NOT* mix airflow types in a chassis; you can use only a single airflow direction in a chassis. If you mismatch the airflow directions, the system powers down in one minute.

- Normal—airflow is from the I/O panel to the PSU.
- Reversed—airflow is from the PSU to the I/O panel.

All fans and PSUs in a configuration must be in the same airflow direction.

Environmental factors can decrease the amount of time required between fan replacements. Check the environmental factors regularly. An increase in temperature and/or particulate matter in the air might affect performance; for example, new equipment installation.

CAUTION: Check the fans at six-month intervals and replace them as necessary. Regularly monitor the speeds of the cooling fans to accurately determine replacement intervals.

Topics:

- [Components](#)
- [Fan module installation](#)
- [Fan module replacement](#)
- [Fan air filter replacement](#)

Components

The following list the fan components:

- S4048T-ON fan module
- S4048T-ON fan module—reverse flow

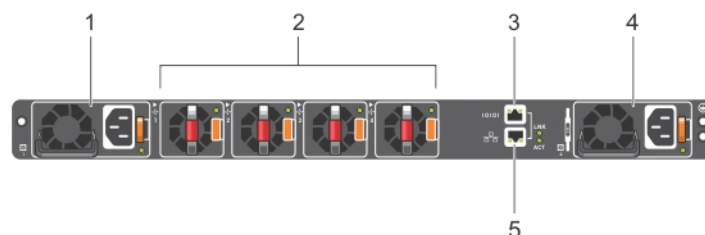

Figure 19. S4048T-ON PSU-side view

- | | |
|--|----------------|
| 1. PSU1 | 2. Fan modules |
| 3. RS-232/RJ-45 serial console port | 4. PSU2 |
| 5. 10/100/1000BaseT Ethernet management port | |

Fan module installation

The fan modules in the S4048T-ON are field replaceable.

Module slot 1 is on the left side of the chassis, module slot 2 is in the middle of the chassis, and module slot 3 is on the right side of the chassis.

CAUTION: DO NOT mix airflow directions. All fans must use the same airflow direction—reverse or normal. If you mix the airflow direction, to avoid damage to the switch, you must correct the mixed airflow.

1. Take the fan module out of the shipping box.
2. Use the grab handle to slide the module into the bay.

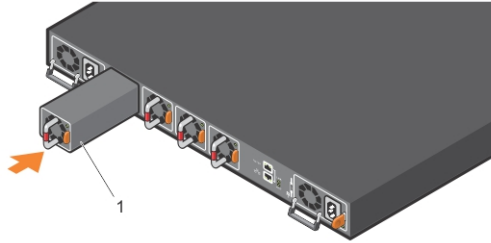

Figure 20. S4048T-ON fan module installation

- a. 1—Fan module

Fan module replacement

CAUTION: Complete steps 2 and 3 within one minute or the system powers down.

1. Use the red-marked grab handle to slide the fan module out of the bay.
2. Use the red-marked grab handle on the replacement module to slide it into the bay.
3. Ensure that the module is secure.

Fan air filter replacement

Environmental factors can decrease the amount of time required between air filter replacements. Check the environmental factors regularly. An increase in temperature and/or particulate matter in the air might affect performance.

CAUTION: Check the fan air filters at six-month intervals and replace them as necessary. To accurately determine air filter replacement intervals, regularly monitor the speeds of the cooling fans. An increase in overall fan speed may indicate a clogged filter.

You must replace the fan air filters with new filters; you cannot clean and reuse the old fan air filters. Replacement filter media must meet the requirements found in GR-63-CORE.

- Minimum dust arrestance of 65%, per ASHRAE Standard 52.1-1992. OR
- Minimum Efficiency Rating Value (MERV) of 2, per ANSI/ASHRAE Standard 52.2-2007.

CAUTION: For Network Equipment Building Systems (NEBS) compliance, use NEBS approved filters.

Use fan air filters with reverse blue-banded air flow systems—PSUs and fans. You can replace the air filters individually on each fan within the system without powering down a PSU module or disrupting traffic.

The fan air filter media slides into the frame from the top. No tools are required.

1. Determine which filters to replace.
2. Unlatch and remove the first module that needs the filter replaced.
3. Slide the existing filter upwards to remove it from the module.

4. Replace the filter with a new filter of the same size.
5. Repeat for the remaining modules that need the filter replaced.

Management ports

Besides the 10 GbE and 40 GbE switch ports, the S4048T-ON system provides several ports for management and storage.

NOTE: The output examples in this section are for reference only. Your output may vary.

Topics:

- [RS-232 console port access](#)
- [Micro USB-B console port access](#)
- [USB storage mount](#)

RS-232 console port access

The RS-232 console port is on the PSU-side of the S4048T-ON chassis.

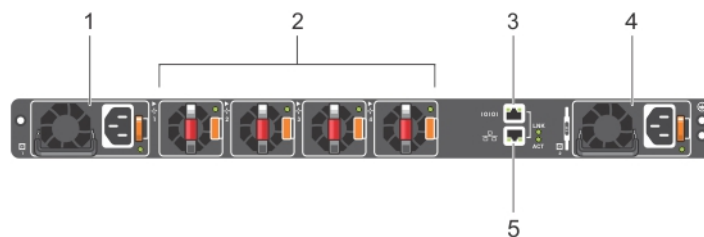

Figure 21. S4048T-ON PSU-side view

- | | |
|--|----------------|
| 1. PSU1 | 2. Fan modules |
| 3. RS-232/RJ-45 serial console port | 4. PSU2 |
| 5. 10/100/1000BaseT Ethernet management port | |

CAUTION: Ensure that any equipment attached to the serial port can support the required 115200 baud rate.

NOTE: When connecting the RJ45 console to the patch panel or terminal server using Cat5e or Cat6 Ethernet cables, the maximum cable length is 100m. However, if the Ethernet cable is disconnected from the patch panel or terminal server but connected to the RJ45 console, the maximum cable length is 6m. If the cable is longer than 6m when disconnected from the panel or server, your switch may not boot.

NOTE: Before starting this procedure, be sure that your PC has a 9-pin serial port and you have a terminal emulation program already installed and running on the PC.

NOTE: If your PC's serial port cannot accept a female DB-9 connector, use a DB-9 male-to-male adaptor.

1. Install the provided RJ-45 connector side of the provided cable into the console port.
2. Install the DB-9 female side of the provided copper cable into your PC's serial port or into other data terminal equipment (DTE) server hardware that you intend to use.
3. Keep the default terminal settings on the console as follows:
 - 115200-baud rate
 - No parity
 - Eight data bits
 - One stop bit

- No flow control

Micro USB-B console port access

The Micro USB-B console port is on the I/O side of the switch.

NOTE: The S4048T-ON switch uses the Silicon Labs CP2109 USB-B chip. To find the correct USB-B universal asynchronous receiver-transmitter (UART) driver, see <https://www.silabs.com/products/development-tools/software/usb-to-uart-bridge-vcp-drivers>.

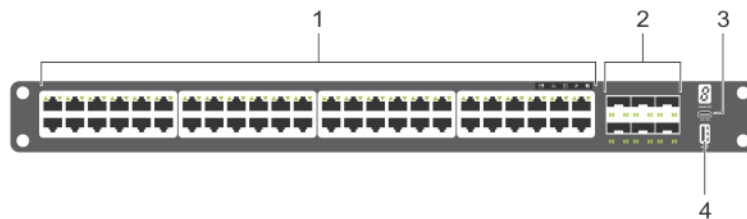

Figure 22. S4048T-ON I/O-side view

- | | |
|---------------------------------|--------------------|
| 1. Forty-eight 10G Base-T ports | 2. Six QSFP+ ports |
| 3. Micro USB-B console port | 4. USB-A port |

NOTE: The Micro USB-B console port does not provide console access in the ONIE bootloader or ONIE. To navigate the ONIE bootloader and access ONIE, use the RS-232/RJ-45 serial console port.

To access the Micro USB-B console port, follow these steps.

1. Power on the PC.
2. Connect the USB-A end of cable into an available USB port on the PC.
3. Connect the Micro USB-B end of cable into the Micro USB-B console port on the system.
4. Power on the system.
5. Install the necessary USB device drivers.
6. Access the S4048T-ON by opening your terminal software emulation program.
7. Confirm that the terminal settings as follows:
 - 115200-baud rate
 - No parity
 - Eight data bits
 - One stop bit
 - No flow control

NOTE: The terminal settings are the same for the Micro USB-B console port as for the RS-232/RJ-45 console port.

USB storage mount

The USB storage supports the FAT file system. The USB storage does not automatically mount. To use USB storage, you must first mount the device.

1. Create a mount directory for the USB.

```
ONIE:/ # mkdir /mnt/usb
```
2. View the fixed disks using the `fdisk` command.

```
ONIE:/mnt # fdisk -l
```

For internal storage:

```
Disk /dev/sda: 15.8 GB, 15829303296 bytes
255 heads, 63 sectors/track, 1924 cylinders
Units = cylinders of 16065 * 512 = 8225280 bytes
```

Device	Boot	Start	End	Blocks	Id	System
/dev/sda1		1	1925	15458303+	ee	EFI GPT

For USB storage:

```
Disk /dev/sdb: 30.9 GB, 30942946304 bytes
64 heads, 32 sectors/track, 29509 cylinders
Units = cylinders of 2048 * 512 = 1048576 bytes
```

Device	Boot	Start	End	Blocks	Id	System
--------	------	-------	-----	--------	----	--------

3. Mount the device /dev/sdb to the /mnt/usb directory.

```
ONIE:/ # mount -t vfat /dev/sdb /mnt/usb
```

i **NOTE:** The following message displays if the /mnt/usb directory is missing: mount: mounting /dev/sdb on /mnt/usb failed: No such file or directory.

i **NOTE:** The following message displays if the USB device is not seen: mount: mounting /dev/sdb on /mnt/usb failed: No such device or address.

4. Add a device to the file systems table, fstab, and mount the file systems.

```
ONIE:/ # vi /etc/fstab
```

```
# FSTAB entry for the ONIE-BOOT partition mounted on /boot
LABEL=ONIE-BOOT /mnt/onie-boot ext4 defaults,rw,errors=remount-ro 0 1
/dev/sdb /mnt/usb vfat defaults 0 1

ONIE:/ # mount -a
```

Specifications

This chapter lists the S4048T–ON specifications.

CAUTION: Operate the product at an ambient temperature not higher than 113°F (45°C).

CAUTION: Lithium Battery Caution: There is a danger of explosion if the battery is incorrectly replaced. Replace only with same or equivalent type of battery. Dispose of the batteries according to the manufacturer's instructions.

NOTE: For RoHS information, see [Restricted Material Compliance](#).

Topics:

- [Chassis physical design](#)
- [IEEE standards](#)
- [Agency compliance](#)

Chassis physical design

Table 3. Chassis physical design

Parameter	Specifications
Height	1.71 inches (43.5 mm).
Width	17.09 inches (434 mm).
Depth	Chassis: 18.11 inches (460 mm). PSU latch: 1.12 inches (28 mm).
Chassis weight with factory-installed components	23 lbs (10.43 kg) (2*PSUs).
Rack clearance required	I/O side: 5 inches (12.7 cm). PSU side: 5 inches (12.7 cm).

Table 4. Environmental parameters

Parameter	Specifications
Operating temperature	32° to 113°F (0° to 45°C).
Operating humidity	5 to 90 percent (RH), noncondensing.
Storage temperature	–40° to 158°F (–40° to 70°C).
Storage and nonoperating humidity	5 to 95 percent (RH), noncondensing.
Maximum thermal output	1568 BTH/hr.
Maximum operational altitude	10,000 feet (3,048 meters).
Maximum nonoperational altitude	No performance degradation to 35,000 feet (10,668 meters).
Shock	Meets Bellcore Zone 4 earthquake requirements, MIL-STD-810.

Table 5. AC power requirements

Parameter	Specifications
Power supply	100–240 VAC 50/60 Hz.
Maximum current draw per system	7.1 A @ 550 Watts 3.4 A @ 550 Watts
Maximum power consumption	550 Watts.
Typical power consumption	338 Watts.

Table 6. DC power requirements

Parameter	Specifications
Minimum/maximum input voltage range	-40.5V/ -48V/ -60V
Input power at full load	-40.5V/970W -48V/930W -60V/ 950W, without fan. -40.5V/980W -48V/940W -60V/ 960W, with fan.
Input current at full load	-40.5V/23.8A -48V/19.0A -60V/ 15.6A, without fan. -40.5V/24.0A -48V/19.2A -60V/ 16.0A, with fan.
Start up VDC—voltage when the system is powered on	39.0+/-1.5V.
Start off VDC—voltage during the boot up process	37.5+/-1.5V.

IEEE standards

The S4048T-ON complies with the following IEEE standards:

- 802.3ab Gigabit Ethernet (1000BASE-T)
- 802.3ae 10 Gigabit Ethernet (10GBASE-X)
- 802.3ba 40 Gigabit Ethernet (40GBase-SR4, 40GBase-CR4) on optical ports
- 802.3u Fast Ethernet (100BASE-TX)
- 802.3z Gigabit Ethernet (1000BASE-X)

Agency compliance

The S4048T-ON is designed to comply with the following safety and agency requirements:

USA Federal Communications Commission Statement

This equipment has been tested and found to comply with the limits for a Class A digital device, pursuant to Part 15 of the FCC rules. These limits are designated to provide reasonable protection against harmful interference when the equipment is operated in a commercial environment. This equipment generates, uses, and can radiate radio frequency energy. If it is not installed and used in accordance to the instructions, it may cause harmful interference to radio communications. Operation of this equipment in a residential area is likely to cause harmful interference, in which case users will be required to take whatever measures necessary to correct the interference at their own expense.

Properly shielded and grounded cables and connectors must be used in order to meet FCC emission limits. Dell EMC is not responsible for any radio or television interference caused by using other than recommended cables and connectors or by unauthorized changes or modifications in the equipment. Unauthorized changes or modification could void the user's authority to operate the equipment.

This device complies with Part 15 of the FCC Rules. Operation is subject to the following two conditions: (1) this device may not cause harmful interference, and (2) this device must accept any interference received, including interference that may cause undesired operation.

Industry Canada Class A emission compliance statement

This Class A digital apparatus complies with Canadian ICES-003.

Avis de conformité à la réglementation d'Industrie Canada

Cet appareil numérique de la classe A est conforme à la norme NMB-003 du Canada.

Figure 23. Canadian Department of Communication Statement

European Union EMC Directive Conformance Statement

This product is in conformity with the protection requirements of EU Council Directive 2004/108/EC on the approximation of the laws of the Member States relating to electromagnetic compatibility. Dell EMC cannot accept responsibility for any failure to satisfy the protection requirements resulting from a nonrecommended modification of this product, including the fitting of non-Dell EMC option cards.

This product has been tested and found to comply with the limits for Class A Information Technology Equipment according to CISPR 22/European Standard EN 55022. The limits for Class A equipment were derived for commercial and industrial environments to provide reasonable protection against interference with licensed communication equipment.

NOTE: This is a Class A product. In a domestic environment, this device may cause radio interference, in which case, you may be required to take adequate measures.

Japan VCCI Compliance for Class A Equipment

この装置は、情報処理装置等電波障害自主規制協議会（VCCI）の基準に基づくクラスA情報技術装置です。この装置を家庭環境で使用すると電波妨害を引き起こすことがあります。この場合には使用者が適切な対策を講ずるよう要求されることがあります。

Figure 24. Japan: VCCI Compliance for Class A Equipment

This is Class A product based on the standard of the Voluntary Control Council For Interference by Information Technology Equipment (VCCI). If this equipment is used in a domestic environment, radio disturbance may arise. When such trouble occurs, the user may be required to take corrective actions.

NOTE: Use the AC power cords with Dell Networking equipment only. Do not use Dell EMC AC power cords with any unauthorized hardware.

本製品に同梱いたしております電源コードセットは、本製品専用です。本電源コードセットは、本製品以外の製品ならびに他の用途でご使用いただくことは出来ません。製品本体には同梱された電源コードセットを使用し、他製品の電源コードセットを使用しないで下さい。

Figure 25. Japan: Warning Label

Korean Certification of Compliance

A급 기기 (업무용 방송통신기자재)	이 기기는 업무용(A급) 전자파적합기기로서 판매자 또는 사용자는 이 점을 주의하시기 바라며, 가정외의 지역에서 사용하는 것을 목적으로 합니다.
------------------------	---

Figure 26. Korean Certification of Compliance

	 [equipment type]
품명(Product Name)	Ethernet Switch
모델명(Model)	[model number]
신청인(Applicant)	Force10 Networks, Inc.
제조사(Manufacturer)	Delta Networks, (Dongguan) Ltd.
제조년월(Manufacturing Date)	[date]
제조국(Country of Origin)	China

Figure 27. Korean Package Label

Safety Standards and Compliance Agency Certifications

- CUS UL 60950-1, 2nd Edition
- CSA 60950-1-03, 2nd Edition
- EN 60950-1, 2nd Edition
- EN 60825-1, 1st Edition
- EN 60825-1 Safety of Laser Products — Part 1: Equipment Classification Requirements and User's Guide
- EN 60825-2 Safety of Laser Products — Part 2: Safety of Optical Fibre Communication Systems
- FDA Regulation 21CFR 1040.10 and 1040.11
- IEC 60950-1, 2nd Ed, including all National Deviations and Group Differences

Electromagnetic Compatibility

Emissions

- International: CISPR 22, Class A
- Australia/New Zealand: AS/NZS CISPR 22, Class A
- Canada: ICES-003, Issue-4, Class A
- Europe: EN55022 2006 (CISPR 22), Class A
- Japan: VCCI V-3/2011.04 Class A
- USA: FCC CFR47 Part 15, Subpart B, Class A

Immunity

- EN 300 386 EMC for Network Equipment
- EN55022, Class A
- EN 55024
- EN 61000-3-2 Harmonic Current Emissions
- EN 61000-3-3 Voltage Fluctuations and Flicker
- EN 61000-4-2 ESD
- EN 61000-4-3 Radiated Immunity
- EN 61000-4-4 EFT
- EN 61000-4-5 Surge
- EN 61000-4-6 Low Frequency Conducted Immunity

Product Recycling and Disposal

You must recycle or discard this system according to applicable local and national regulations. Dell EMC encourages owners of information technology (IT) equipment to responsibly recycle their equipment when it is no longer needed. Dell EMC offers a variety of product return programs and services in several countries to assist equipment owners in recycling their IT products.

Waste Electrical and Electronic Equipment (WEEE) Directive for Recovery, Recycle and Reuse of IT and Telecommunications Products

Dell EMC switches are labeled in accordance with European Directive 2002/96/EC concerning waste electrical and electronic equipment (WEEE). The Directive determines the framework for the return and recycling of used appliances as applicable throughout the European Union. This label is applied to various products to indicate that the product is not to be thrown away, but rather reclaimed upon end of life per this Directive.



Figure 28. The European WEEE Symbol

In accordance with the European WEEE Directive, electrical and electronic equipment (EEE) is to be collected separately and to be reused, recycled, or recovered at end of life. Users of EEE with the WEEE marking per Annex IV of the WEEE Directive, as shown above, must not dispose of end of life EEE as unsorted municipal waste, but use the collection framework available to customers for the return, recycling and recovery of WEEE. Customer participation is important to minimize any potential effects of EEE on the environment and human health due to the potential presence of hazardous substances in EEE.

Dell EMC products, which fall within the scope of the WEEE, are labeled with the crossed-out wheeled-bin symbol, as shown above, as required by WEEE.

To access information on Dell EMC product recycling offerings, go to <https://www.dell.com/support/>.

Dell EMC support

The Dell EMC support site provides a range of documents and tools to assist you with using Dell EMC equipment and mitigating the impact of network outages. Through the support site you can obtain technical information regarding Dell EMC products, access software upgrades and patches, download available management software, and manage your open cases. The Dell EMC support site provides integrated, secure access to these services.

To access the Dell EMC support site, go to www.dell.com/support/. To display information in your language, scroll down to the bottom of the web page and select your country from the drop-down menu.

- To obtain product-specific information, enter the 7-character service tag or 11-digit express service code of your S4048T-ON system and click **Submit**.
- To receive additional kinds of technical support, click **Contact Us**. On the **Contact Information** web page, click **Technical Support**.
- To access S4048T documentation, go to www.dell.com/manuals/.
- To search for drivers and downloads, go to www.dell.com/drivers/.
- To participate in Dell EMC community blogs and forums, go to www.dell.com/community.

To view the service tag or express service code on a system, pull out the tag as shown in the following illustration.

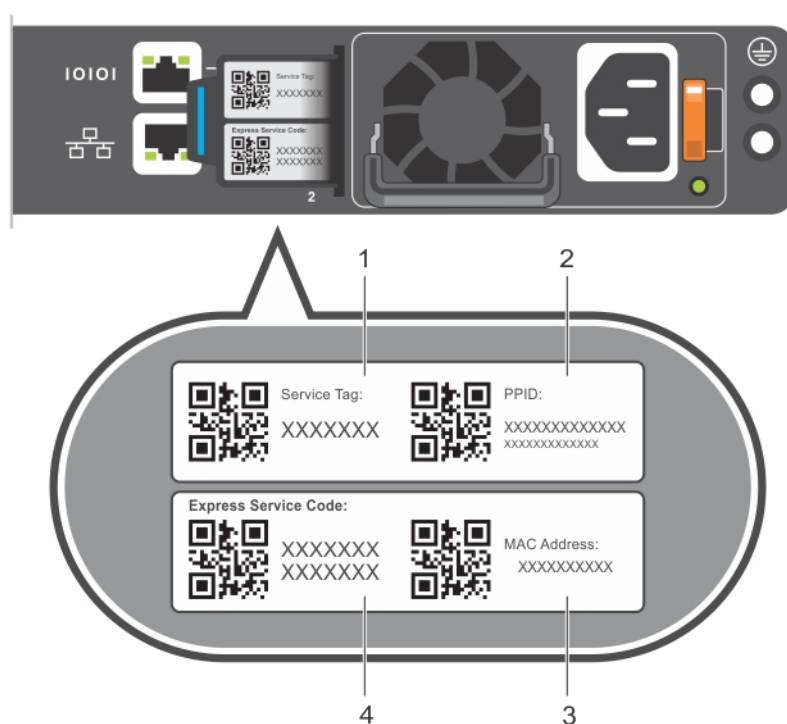

Figure 29. S4048T-ON luggage tag

1. Service tag
2. PPID
3. MAC address
4. Express service code