

Latitude 7220 Rugged Extreme Tablet

Service Manual

Notes, cautions, and warnings

 **NOTE:** A NOTE indicates important information that helps you make better use of your product.

 **CAUTION:** A CAUTION indicates either potential damage to hardware or loss of data and tells you how to avoid the problem.

 **WARNING:** A WARNING indicates a potential for property damage, personal injury, or death.

Chapter 1: Working on your tablet.....	6
Safety instructions.....	6
Installation and operating instructions.....	6
Before working inside your tablet.....	7
Safety precautions.....	7
Electrostatic discharge—ESD protection.....	8
ESD field service kit	8
Transporting sensitive components.....	9
After working inside your tablet.....	9
Chapter 2: Major components of your system.....	11
Chapter 3: Removing and installing components.....	14
Recommended tools.....	14
Screw list.....	14
Batteries.....	16
Lithium-ion battery precautions.....	16
Removing the batteries.....	16
Installing the batteries.....	17
Subscriber Identification Module (SIM) card.....	18
Removing the uSIM.....	18
Inserting the uSIM.....	19
Stylus.....	20
Removing the stylus.....	20
Installing the stylus.....	21
Display assembly.....	22
Removing the display assembly.....	22
Installing the display assembly.....	26
Function keys.....	30
Removing the function keys.....	30
Installing the function keys.....	31
Heat sink.....	32
Removing the SSD heat-sink.....	32
Installing the SSD heat-sink.....	33
System fan.....	34
Removing the system fan.....	34
Installing the system fan.....	35
Solid-state drive.....	36
Removing the M.2 2230 solid-state drive.....	36
Removing the M.2 2280 solid-state drive.....	36
Installing M.2 2230 solid-state drive.....	37
Installing the M.2 2280 solid-state drive.....	37
WLAN card.....	38
Removing the WLAN card.....	38

Installing the WLAN card.....	39
WWAN card.....	41
Removing the WWAN card.....	41
Installing the WWAN card.....	42
Microphone.....	43
Removing the microphone.....	43
Installing the microphone.....	44
Front camera.....	44
Removing the front camera.....	44
Installing the front camera.....	46
Coin-cell battery.....	48
Removing the coin-cell battery.....	48
Installing the coin-cell battery.....	49
System board.....	50
Removing the system board.....	50
Installing the system board.....	55
Rear Camera.....	58
Removing the rear camera.....	58
Installing the rear camera.....	59
Micro serial port and power connector port.....	60
Removing micro serial port and power connector port.....	60
Installing micro serial port and power connector port.....	61
Docking Board.....	63
Removing the docking board.....	63
Installing the docking board.....	64
Smart card reader and wireless passthrough daughterboard.....	65
Removing the smart card reader and wireless passthrough daughterboard.....	65
Installing the smart card reader and wireless passthrough daughterboard.....	67
Chapter 4: Software.....	70
Drivers and downloads.....	70
Chapter 5: System setup.....	71
Boot menu.....	71
Navigation keys.....	71
Boot Sequence.....	72
System setup options.....	72
General options.....	72
System information.....	73
Video.....	75
Security.....	75
Secure boot.....	76
Intel Software Guard Extensions.....	77
Performance.....	77
Power management.....	78
POST behavior.....	79
Manageability.....	80
Virtualization support.....	80
Wireless.....	81

Maintenance screen.....	81
System logs.....	82
SupportAssist System Resolution.....	82
About.....	82
Updating the BIOS.....	82
Updating the BIOS in Windows.....	82
Updating the BIOS using the USB drive in Windows.....	83
Updating the BIOS from the F12 One-Time boot menu.....	83
System and setup password.....	84
Assigning a system setup password.....	84
Deleting or changing an existing system setup password.....	85
Chapter 6: Troubleshooting.....	86
Handling swollen Lithium-ion batteries.....	86
Dell SupportAssist Pre-boot System Performance Check diagnostics.....	87
Running the ePSA diagnostics.....	87
System diagnostic lights.....	87
Recovering the operating system.....	88
WiFi power cycle.....	89
Chapter 7: Getting help and contacting Dell.....	90

Working on your tablet

Topics:

- [Safety instructions](#)

Safety instructions

Use the following safety guidelines to protect your computer from potential damage and to ensure your personal safety. Unless otherwise noted, each procedure included in this document assumes that you have read the safety information that shipped with your computer.

⚠ WARNING: Before working inside your computer, read the safety information that is shipped with your computer. For more safety best practices, see the Regulatory Compliance home page at www.dell.com/regulatory_compliance.

⚠ WARNING: Disconnect your computer from all power sources before opening the computer cover or panels. After you finish working inside the computer, replace all covers, panels, and screws before connecting your computer to an electrical outlet.

⚠ CAUTION: To avoid damaging the computer, ensure that the work surface is flat, dry, and clean.

⚠ CAUTION: To avoid damaging the components and cards, handle them by their edges, and avoid touching the pins and the contacts.

⚠ CAUTION: You should only perform troubleshooting and repairs as authorized or directed by the Dell technical assistance team. Damage due to servicing that is not authorized by Dell is not covered by your warranty. See the safety instructions that is shipped with the product or at www.dell.com/regulatory_compliance.

⚠ CAUTION: Before touching anything inside your computer, ground yourself by touching an unpainted metal surface, such as the metal at the back of the computer. While you work, periodically touch an unpainted metal surface to dissipate static electricity which could harm internal components.

⚠ CAUTION: When you disconnect a cable, pull it by its connector or its pull tab, not the cable itself. Some cables have connectors with locking tabs or thumbscrews that you must disengage before disconnecting the cable. When disconnecting cables, keep them evenly aligned to avoid bending the connector pins. When connecting cables, ensure that the ports and the connectors are correctly oriented and aligned.

⚠ CAUTION: Press and eject any installed card from the media-card reader.

⚠ CAUTION: Exercise caution when handling Lithium-ion batteries in laptops. Swollen batteries should not be used and should be replaced and disposed properly.

ⓘ NOTE: The color of your computer and certain components may appear differently than shown in this document.

Installation and operating instructions

An installation manual is provided with each unit to direct the user on proper installation and operation of the device.

ⓘ NOTE: Warning and Safety instructions are provided in English and French for Canadian Certification.

ⓘ NOTE: Suitable for use in class I, division 2, groups A, B, C and D hazardous locations, or nonhazardous locations only.

⚠ WARNING: Explosion hazard - Do not disconnect equipment (rechargeable Lithium-ion battery) unless power has been switched off or the area is known to be non-hazardous.

⚠ WARNING: Explosion hazard - Substitution of any component can impair suitability for class I, division 2.

ℹ NOTE: Ambient temperature: - Range as under Ratings.

ℹ NOTE: Temperature code - T4A

⚠ WARNING: Explosion hazard - Do not use these external connections in a hazardous location: POGO ports, smart card reader, SIM-card slot, mini-RS232 port, USB 3.0 port, DC-in Jack, audio jack, mini-HDMI port, microSD-card reader, antenna pass-through port, or USB type-C port.

⚠ WARNING: Explosion hazard - The tablet is to be only powered from the battery pack while in hazardous locations. The power adapter is not certified for use in hazardous locations and not to be used in hazardous locations.

⚠ WARNING: Explosion hazard - The battery must only be changed or charged in an area free of ignitable concentrations.

⚠ WARNING: Explosion hazard - Do not remove or replace the microSD-card and/or battery pack while the circuit is live unless the area is free of ignitable concentrations.

ℹ NOTE: To avoid risk of fire or explosion, replace battery manufactured by Simplo Technology Co., Ltd. only. Use of any another battery can cause risk of fire or explosion.

Before working inside your tablet

About this task

To avoid damaging your tablet, perform the following steps before you begin working inside the tablet:

Steps

1. Ensure that you follow the [Safety Instruction](#).
2. Ensure that your work surface is flat and clean to prevent the tablet cover from being scratched.
3. Turn off your tablet.
4. If the tablet is connected to a docking device (docked) such as the mobile keyboard or a docking station, undock it.
5. Disconnect your tablet and all attached devices from their electrical outlets.
6. Press and hold the power button while the tablet is unplugged to ground the system board.
 - ℹ NOTE:** To avoid electrostatic discharge, ground yourself by using a wrist grounding strap or by periodically touching an unpainted metal surface simultaneously as touching a connector on the back of the tablet.
7. Remove any installed ExpressCards or Smart Cards from the appropriate slots.

Safety precautions

The safety precautions chapter details the primary steps to be taken before performing any disassembly instructions.

Observe the following safety precautions before you perform any installation or break/fix procedures involving disassembly or reassembly:

- Turn off the tablet and all attached peripherals.
- Disconnect the tablet and all attached peripherals from AC power.
- Disconnect all network cables, telephone, and telecommunications lines from the system.
- Use an ESD field service kit when working inside any tablet to avoid electrostatic discharge (ESD) damage.
- After removing any system component, carefully place the removed component on an antistatic mat.
- Wear shoes with nonconductive rubber soles to reduce the chance of getting electrocuted.

Bonding

Bonding is a method for connecting two or more grounding conductors to the same electrical potential. This is done by using a field service electrostatic discharge (ESD) kit. When connecting a bonding wire, ensure that it is connected to bare metal and never to a painted or nonmetal surface. The wrist strap should be secure and in full contact with your skin, and ensure that you remove all jewelry such as watches, bracelets, or rings prior to bonding yourself and the equipment.

Electrostatic discharge—ESD protection

ESD is a major concern when you handle electronic components, especially sensitive components such as expansion cards, processors, memory DIMMs, and system boards. Very slight charges can damage circuits in ways that may not be obvious, such as intermittent problems or a shortened product life span. As the industry pushes for lower power requirements and increased density, ESD protection is an increasing concern.

Due to the increased density of semiconductors used in recent Dell products, the sensitivity to static damage is now higher than in previous Dell products. For this reason, some previously approved methods of handling parts are no longer applicable.

Two recognized types of ESD damage are catastrophic and intermittent failures.

- **Catastrophic** – Catastrophic failures represent approximately 20 percent of ESD-related failures. The damage causes an immediate and complete loss of device functionality. An example of catastrophic failure is a memory DIMM that has received a static shock and immediately generates a "No POST/No Video" symptom with a beep code emitted for missing or nonfunctional memory.
- **Intermittent** – Intermittent failures represent approximately 80 percent of ESD-related failures. The high rate of intermittent failures means that most of the time when damage occurs, it is not immediately recognizable. The DIMM receives a static shock, but the tracing is merely weakened and does not immediately produce outward symptoms related to the damage. The weakened trace may take weeks or months to melt, and in the meantime may cause degradation of memory integrity, intermittent memory errors, etc.

The more difficult type of damage to recognize and troubleshoot is the intermittent (also called latent or "walking wounded") failure.

Perform the following steps to prevent ESD damage:

- Use a wired ESD wrist strap that is properly grounded. The use of wireless anti-static straps is no longer allowed; they do not provide adequate protection. Touching the chassis before handling parts does not ensure adequate ESD protection on parts with increased sensitivity to ESD damage.
- Handle all static-sensitive components in a static-safe area. If possible, use anti-static floor pads and workbench pads.
- When unpacking a static-sensitive component from its shipping carton, do not remove the component from the anti-static packing material until you are ready to install the component. Before unwrapping the anti-static packaging, ensure that you discharge static electricity from your body.
- Before transporting a static-sensitive component, place it in an anti-static container or packaging.

ESD field service kit

The unmonitored Field Service kit is the most commonly used service kit. Each Field Service kit includes three main components: anti-static mat, wrist strap, and bonding wire.

Components of an ESD field service kit

The components of an ESD field service kit are:

- **Anti-Static Mat** – The anti-static mat is dissipative and parts can be placed on it during service procedures. When using an anti-static mat, your wrist strap should be snug and the bonding wire should be connected to the mat and to any bare metal on the system being worked on. Once deployed properly, service parts can be removed from the ESD bag and placed directly on the mat. ESD-sensitive items are safe in your hand, on the ESD mat, in the system, or inside a bag.
- **Wrist Strap and Bonding Wire** – The wrist strap and bonding wire can be either directly connected between your wrist and bare metal on the hardware if the ESD mat is not required, or connected to the anti-static mat to protect hardware that is temporarily placed on the mat. The physical connection of the wrist strap and bonding wire between your skin, the ESD mat, and the hardware is known as bonding. Use only Field Service kits with a wrist strap, mat, and bonding wire. Never use wireless wrist straps. Always be aware that the internal wires of a wrist strap are prone to damage from normal wear and tear, and must be checked regularly with a wrist strap tester in order to avoid accidental ESD hardware damage. It is recommended to test the wrist strap and bonding wire at least once per week.

- **ESD Wrist Strap Tester** – The wires inside of an ESD strap are prone to damage over time. When using an unmonitored kit, it is a best practice to regularly test the strap prior to each service call, and at a minimum, test once per week. A wrist strap tester is the best method for doing this test. If you do not have your own wrist strap tester, check with your regional office to find out if they have one. To perform the test, plug the wrist-strap's bonding-wire into the tester while it is strapped to your wrist and push the button to test. A green LED is lit if the test is successful; a red LED is lit and an alarm sounds if the test fails.
- **Insulator Elements** – It is critical to keep ESD sensitive devices, such as plastic heat sink casings, away from internal parts that are insulators and often highly charged.
- **Working Environment** – Before deploying the ESD Field Service kit, assess the situation at the customer location. For example, deploying the kit for a server environment is different than for a desktop or portable environment. Servers are typically installed in a rack within a data center; desktops or portables are typically placed on office desks or cubicles. Always look for a large open flat work area that is free of clutter and large enough to deploy the ESD kit with additional space to accommodate the type of system that is being repaired. The workspace should also be free of insulators that can cause an ESD event. On the work area, insulators such as Styrofoam and other plastics should always be moved at least 12 inches or 30 centimeters away from sensitive parts before physically handling any hardware components
- **ESD Packaging** – All ESD-sensitive devices must be shipped and received in static-safe packaging. Metal, static-shielded bags are preferred. However, you should always return the damaged part using the same ESD bag and packaging that the new part arrived in. The ESD bag should be folded over and taped shut and all the same foam packing material should be used in the original box that the new part arrived in. ESD-sensitive devices should be removed from packaging only at an ESD-protected work surface, and parts should never be placed on top of the ESD bag because only the inside of the bag is shielded. Always place parts in your hand, on the ESD mat, in the system, or inside an anti-static bag.
- **Transporting Sensitive Components** – When transporting ESD sensitive components such as replacement parts or parts to be returned to Dell, it is critical to place these parts in anti-static bags for safe transport.

ESD protection summary

It is recommended that all field service technicians use the traditional wired ESD grounding wrist strap and protective anti-static mat at all times when servicing Dell products. In addition, it is critical that technicians keep sensitive parts separate from all insulator parts while performing service and that they use anti-static bags for transporting sensitive components.

Transporting sensitive components

When transporting ESD sensitive components such as replacement parts or parts to be returned to Dell, it is critical to place these parts in anti-static bags for safe transport.

Lifting equipment

Adhere to the following guidelines when lifting heavy weight equipment:

 **CAUTION: Do not lift greater than 50 pounds. Always obtain additional resources or use a mechanical lifting device.**

1. Get a firm balanced footing. Keep your feet apart for a stable base, and point your toes out.
2. Tighten stomach muscles. Abdominal muscles support your spine when you lift, offsetting the force of the load.
3. Lift with your legs, not your back.
4. Keep the load close. The closer it is to your spine, the less force it exerts on your back.
5. Keep your back upright, whether lifting or setting down the load. Do not add the weight of your body to the load. Avoid twisting your body and back.
6. Follow the same techniques in reverse to set the load down.

After working inside your tablet

About this task

After you complete any replacement procedure, ensure that you connect external devices, cards, and cables before turning on your tablet.

 **CAUTION: To avoid damage to the tablet, use only the battery that is designed for this particular Dell tablet. Do not use batteries that are designed for other Dell tablets.**

Steps

1. Connect any external devices, such as a mobile keyboard or a docking station, and replace any cards, such as an ExpressCard.
2. Connect your tablet and all attached devices to their electrical outlets.
3. Turn on your tablet.

Major components of your system

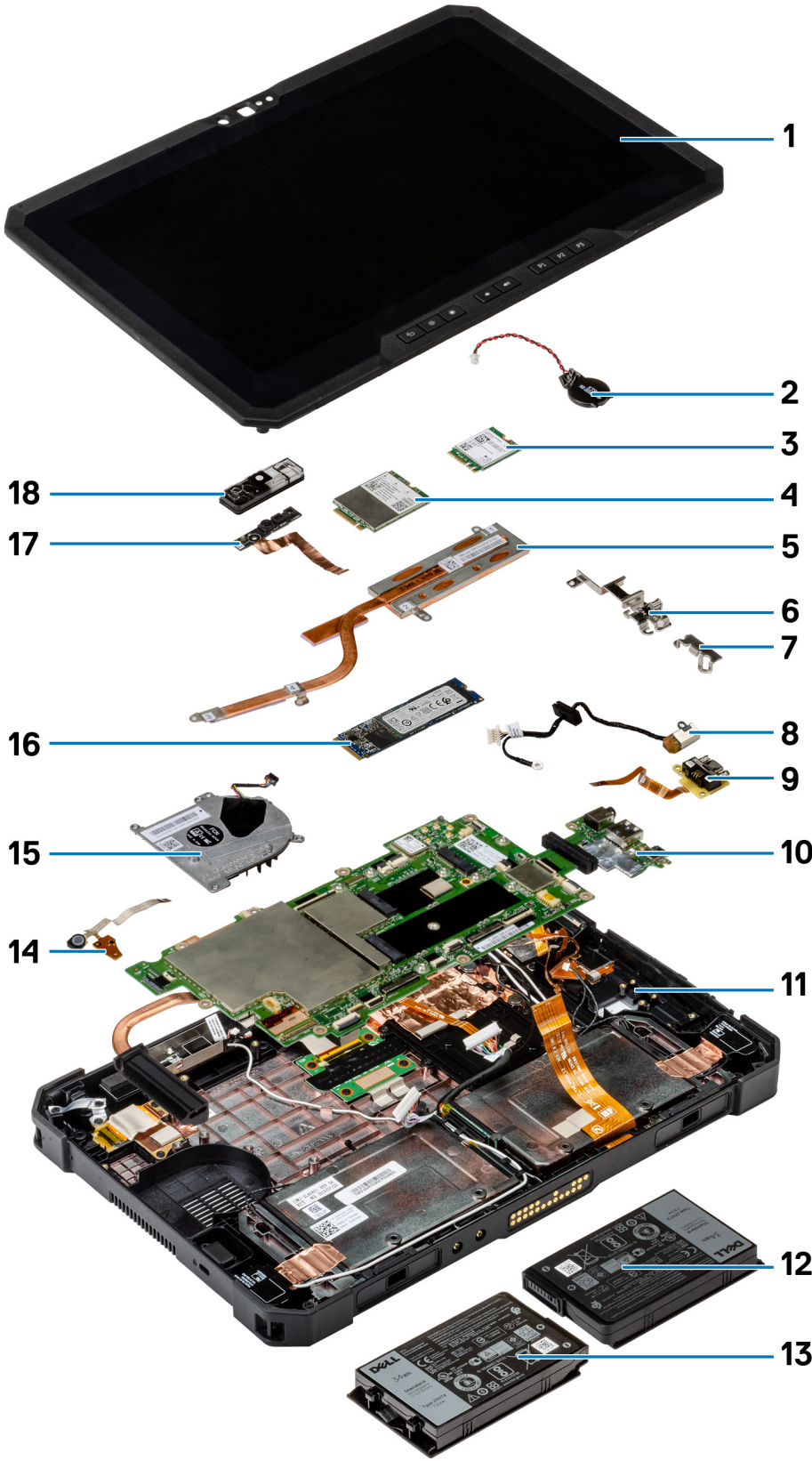

1. Display assembly
2. Coin-cell battery
3. WLAN card
4. WWAN card
5. Heat-sink
6. USB Type-C bracket
7. Mini-serial bracket
8. Power adapter port
9. Mini-serial port
10. System board
11. NFC antenna
12. Left battery (as viewed from the back)
13. Right battery (as viewed from the back)
14. Microphone assembly circuit board
15. System fan
16. Solid-state drive
17. Front camera cable
18. Front camera cover

 **NOTE:** Dell provides a list of components and their part numbers for the original system configuration purchased. These parts are available according to warranty coverages purchased by the customer. Contact your Dell sales representative for purchase options.

Removing and installing components

NOTE: The images in this document may differ from your computer depending on the configuration you ordered.

Topics:

- Recommended tools
- Screw list
- Batteries
- Subscriber Identification Module (SIM) card
- Stylus
- Display assembly
- Function keys
- Heat sink
- System fan
- Solid-state drive
- WLAN card
- WWAN card
- Microphone
- Front camera
- Coin-cell battery
- System board
- Rear Camera
- Micro serial port and power connector port
- Docking Board
- Smart card reader and wireless passthrough daughterboard

Recommended tools

The procedures in this document require the following tools:

- Phillips #0 screwdriver
- Phillips #1 screwdriver
- Phillips #2 screwdriver
- Plastic scribe

















NOTE: The #0 screw driver is for screws 0-1, and the #1 screw driver is for screws 2-4.

Screw list

NOTE: When removing screws from a component, it is recommended to note the screw type, the quantity of screws, and then place them in a screw storage box. This is to ensure that the correct number of screws and correct screw type is restored when the component is replaced.

NOTE: Screw color may vary with the configuration ordered.

Table 1. Screw list

Component	Screw type	Quantity	Screw image
LCD	M2.5x5	19	
Function keys	M2x5	6	
SSD Heat-sink	M2x3	5	
System fan	M2x5	4	
Solid-state drive (SSD)	M2x3	1	
M.2 WLAN	M2x3	1	
M.2 WWAN	M2x3	1	
Microphone	M2x5	2	
Front camera	M2x3	1	
System board	M2x5 M2x3 M1.6x5	11 2 2	  
Rear camera	M2x5	3	
Micro serial port and power connector port	M2x5 M1.6x5	6 2	 
Docking Board	M2x5	5	
Smart card reader and wireless passthrough daughterboard	M2x5	10	

Batteries

Lithium-ion battery precautions

CAUTION:

- Exercise caution when handling Lithium-ion batteries.
- Discharge the battery completely before removing it. Disconnect the AC power adapter from the system and operate the computer solely on battery power—the battery is fully discharged when the computer no longer turns on when the power button is pressed.
- Do not crush, drop, mutilate, or penetrate the battery with foreign objects.
- Do not expose the battery to high temperatures, or disassemble battery packs and cells.
- Do not apply pressure to the surface of the battery.
- Do not bend the battery.
- Do not use tools of any kind to pry on or against the battery.
- Ensure any screws during the servicing of this product are not lost or misplaced, to prevent accidental puncture or damage to the battery and other system components.
- If the battery gets stuck inside your computer as a result of swelling, do not try to release it as puncturing, bending, or crushing a lithium-ion battery can be dangerous. In such an instance, contact Dell technical support for assistance. See www.dell.com/contactdell.
- Always purchase genuine batteries from www.dell.com or authorized Dell partners and resellers.
- Swollen batteries should not be used and should be replaced and disposed properly. For guidelines on how to handle and replace swollen Lithium-ion batteries, see [Handling swollen Lithium-ion batteries](#).

Removing the batteries

Prerequisites

1. Follow the procedure in [before working inside your tablet](#).

 **NOTE:** This tablet can accommodate two hot-swap capable batteries (Primary and optional). The removal procedure of the primary and optional battery are identical.

About this task

The figure indicates the location of the batteries and provides a visual representation of the removal procedure.

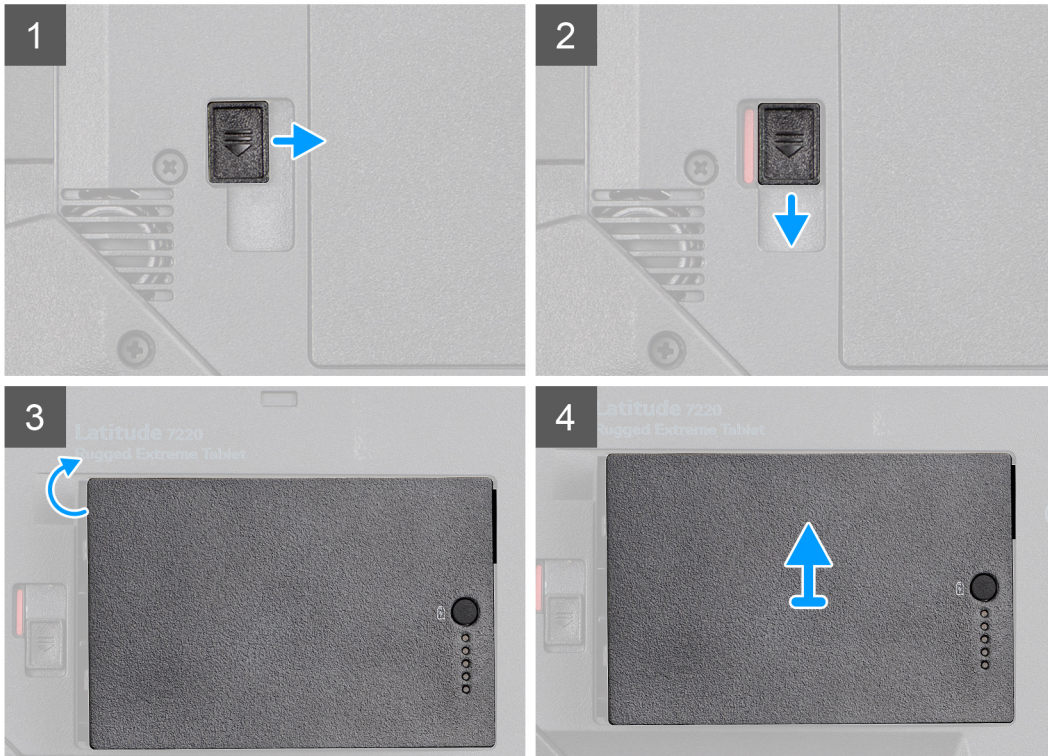
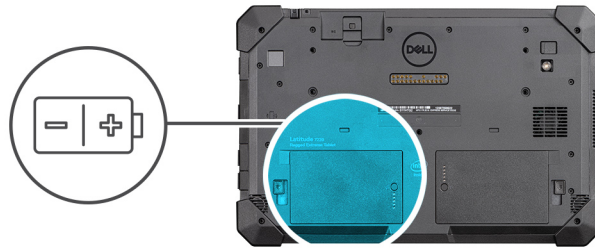

Steps

1. Slide the battery release latch to the unlock position.
2. Slide the latch down to unlock the battery.
3. Lift the battery out of the battery bay.
4. Remove the battery from the tablet.

Installing the batteries

Prerequisites

If you are replacing a component, remove the existing component before performing the installation procedure.

About this task

NOTE: This tablet can accommodate two hot-swap capable batteries (Primary and optional). The installation procedure of the primary and optional battery are identical.

The figure indicates the location of the battery and provides a visual representation of the installation procedure.

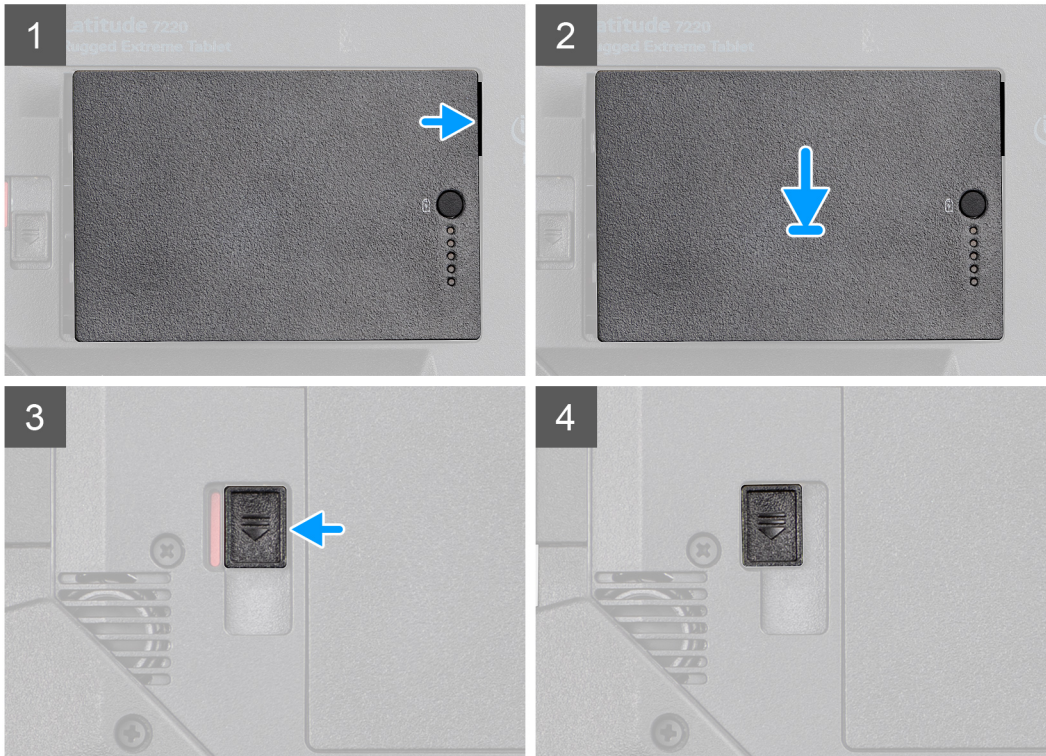
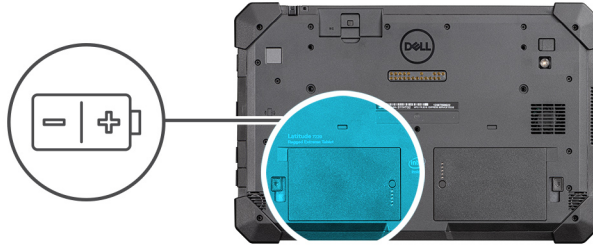

Steps

1. Align the pins on the battery with the connector on the tablet.
i **NOTE:** Ensure that the metal pin of the battery is aligned in place.
2. Place the battery into the battery bay until it clicks into place.
3. Slide the battery latch to the locked state.
4. Ensure that the battery release latch is in the locked state.

Next steps

1. Follow the procedure in [after working inside your tablet](#).

Subscriber Identification Module (SIM) card

Removing the uSIM

Prerequisites

1. Follow the procedure in [before working inside your tablet](#).
2. Remove the [batteries](#).

About this task

The figure indicates the location of the uSIM and provides a visual representation of the removal procedure.

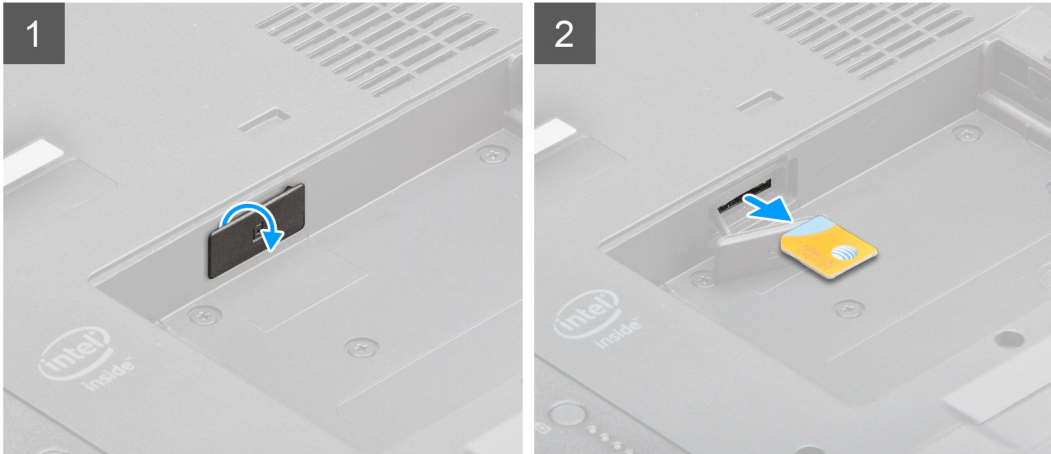
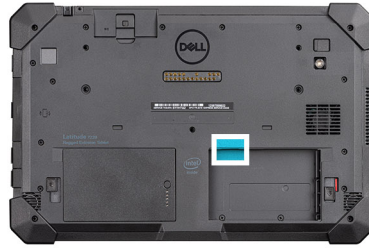

Steps

1. Open the uSIM slot cap.
2. Press the uSIM card, and slide it out of the slot.

i **NOTE:** Use a flat pointed scribe to ease removing the SIM.

Inserting the uSIM

Prerequisites

If you are replacing a component, remove the existing component before performing the installation procedure.

About this task

The figure indicates the location of the uSIM and provides a visual representation of the installation procedure.

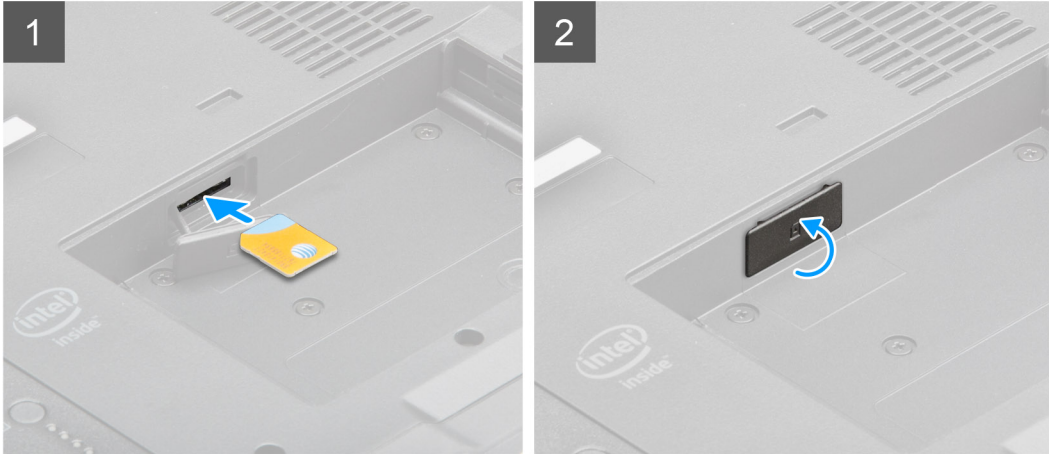

Steps

1. Insert the uSIM card in the slot until it is locked.
2. Close the uSIM slot cap to initial state.

Next steps

1. Install the [batteries](#).
2. Follow the procedure in [after working inside your tablet](#).

Stylus

Removing the stylus

Prerequisites

1. Follow the procedure in [before working inside your tablet](#).

About this task

The figure indicates the location of the stylus and provides a visual representation of the removal procedure.

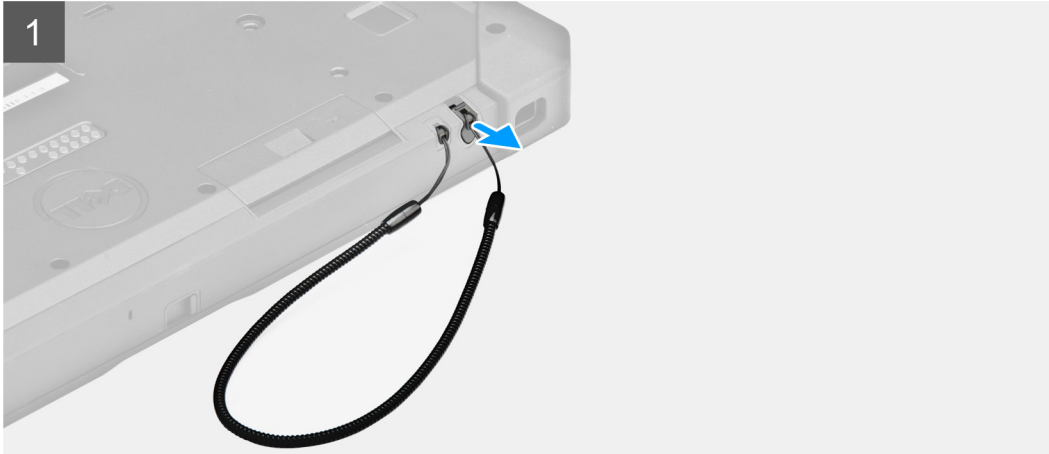

Steps

1. Slide the stylus upward using the groove on the stylus pen.
NOTE: Avoid pulling the stylus with the stretchable thread.
2. Loosen the knot and slip the stylus through the hole to remove the tether from the chassis.

Installing the stylus

Prerequisites

If you are replacing a component, remove the existing component before performing the installation procedure.

About this task

The figure indicates the location of the stylus and provides a visual representation of the installation procedure.

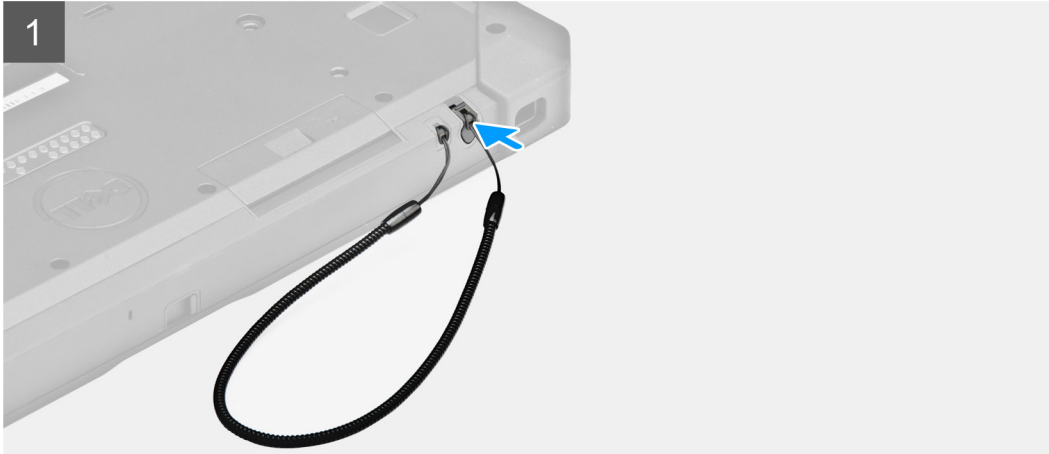

Steps

1. Slip the stylus through the hole to create a knot that holds the tether to the chassis.
2. Insert the stylus into the slot on the tablet.

NOTE: When not in use, avoid hanging the stylus that is detached from its groove.

Next steps

1. Follow the procedure in [after working inside your tablet](#).

Display assembly

Removing the display assembly

Prerequisites

1. Follow the procedure in [before working inside your tablet](#).
2. Remove the [batteries](#).

About this task

The figure indicates the location of the display assembly and provides a visual representation of the removal procedure.



19x
M2.5x5



1



2



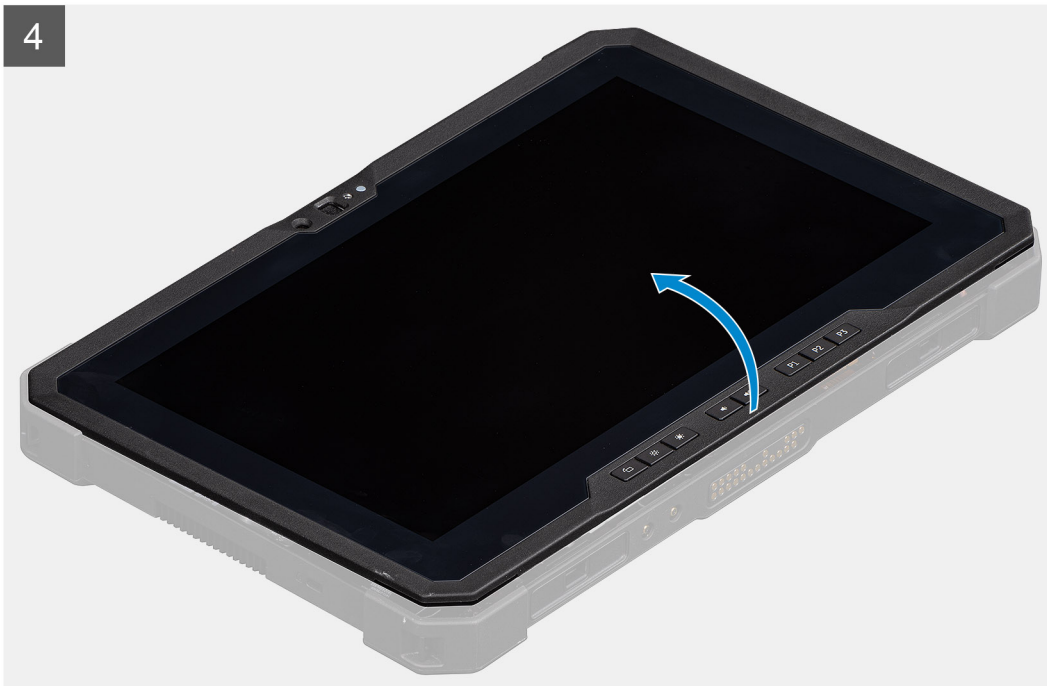
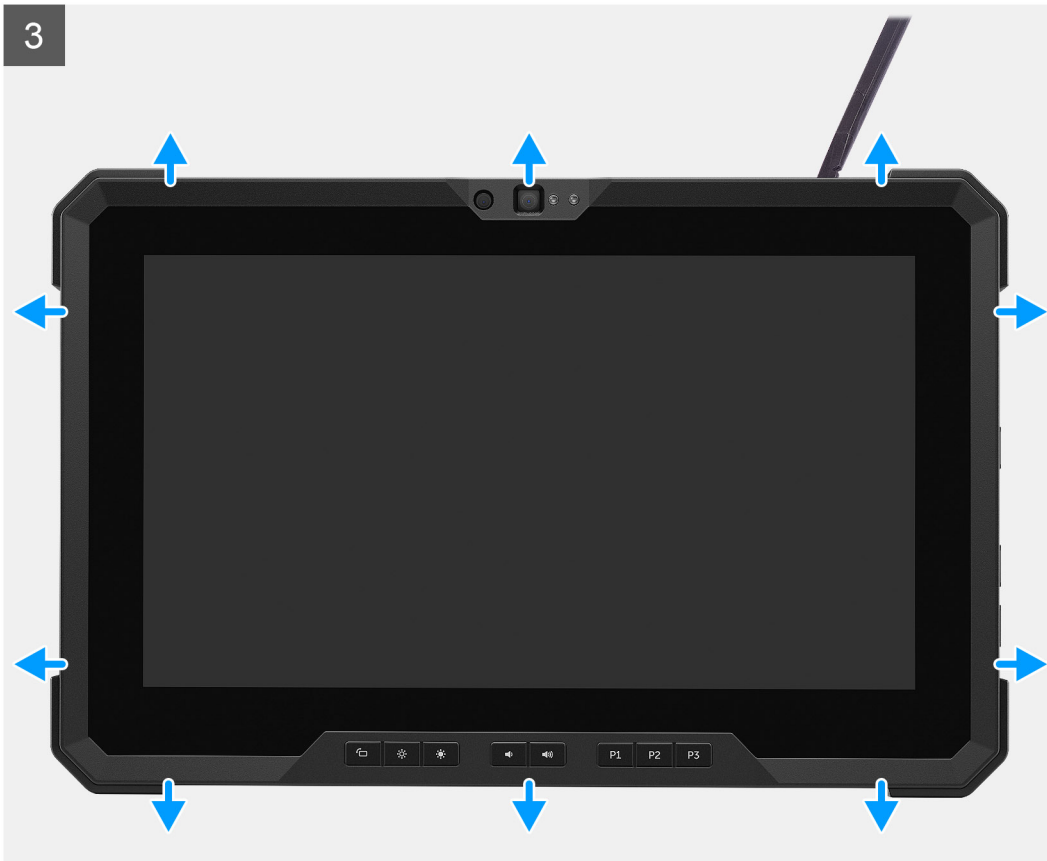

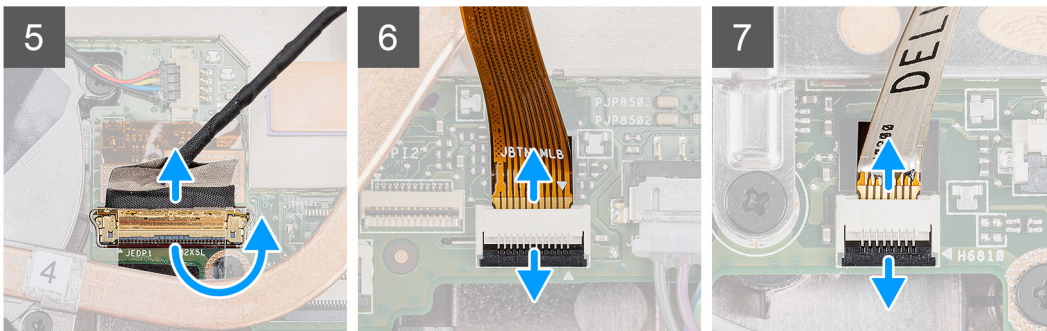
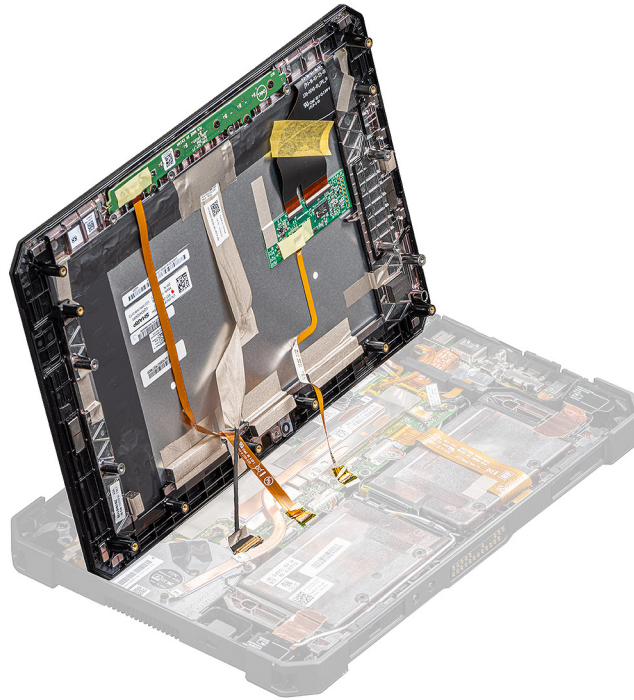

Steps

1. Place the tablet on a flat and clean surface and remove the 19 (M2.5x5) screws that secure the display assembly to the chassis.
2. Flip the tablet.
3. Using a plastic scribe, gently pry the edges evenly to unlock the plastic clips that secure the display assembly to the chassis.
 - i** **NOTE:** Tip of the plastic scribe should be inserted to avoid damage to the seal on the display assembly and to the clips that secure the display assembly to the chassis.
4. Flip the LCD panel by an angle less than 90°.
 - i** **NOTE:** Ensure not to flip more than 90° angle, as the LCD panel ports and cables are connected to the system board and may damage the LCD cables.
5. Remove the adhesive tape. Using a plastic scribe, lift the latch and disconnect the eDP cable from the connector on the system board.
6. Remove the adhesive tape. Using a plastic scribe, lift the latch and release the function key cable from the connector on the system board.
7. Remove the adhesive tape. Using a plastic scribe, lift the latch and release the touch cable that is connected to the system board.

Installing the display assembly

Prerequisites

If you are replacing a component, remove the existing component before performing the installation procedure.

About this task

The figure indicates the location of the component and provides a visual representation of the installation procedure.

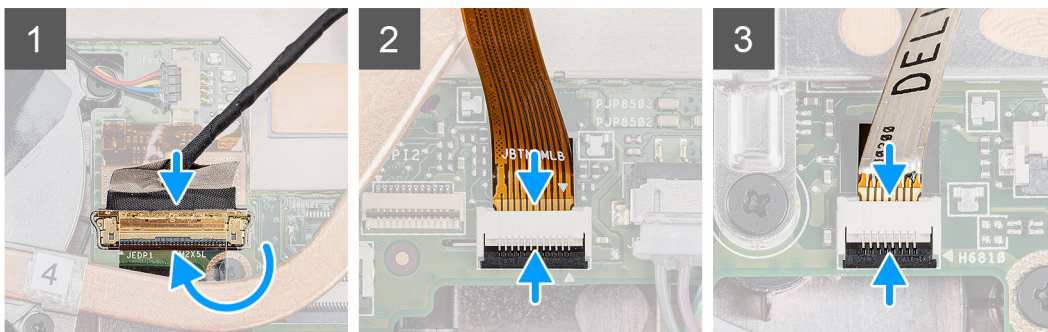
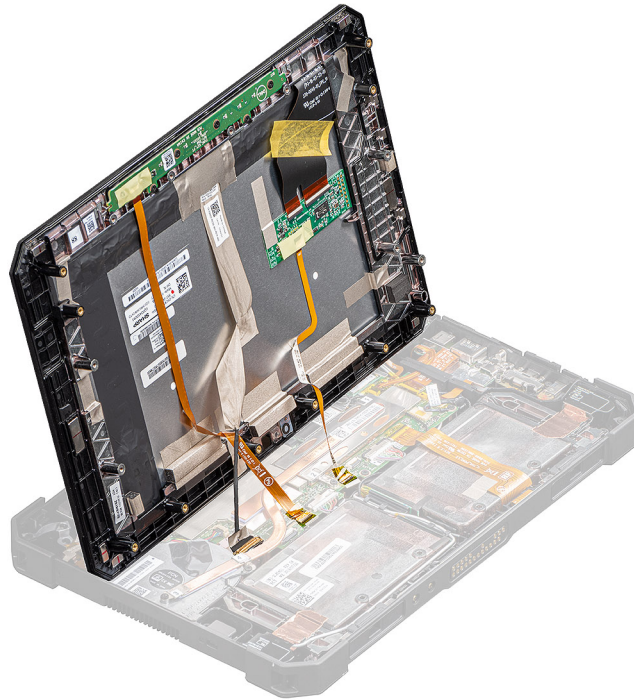

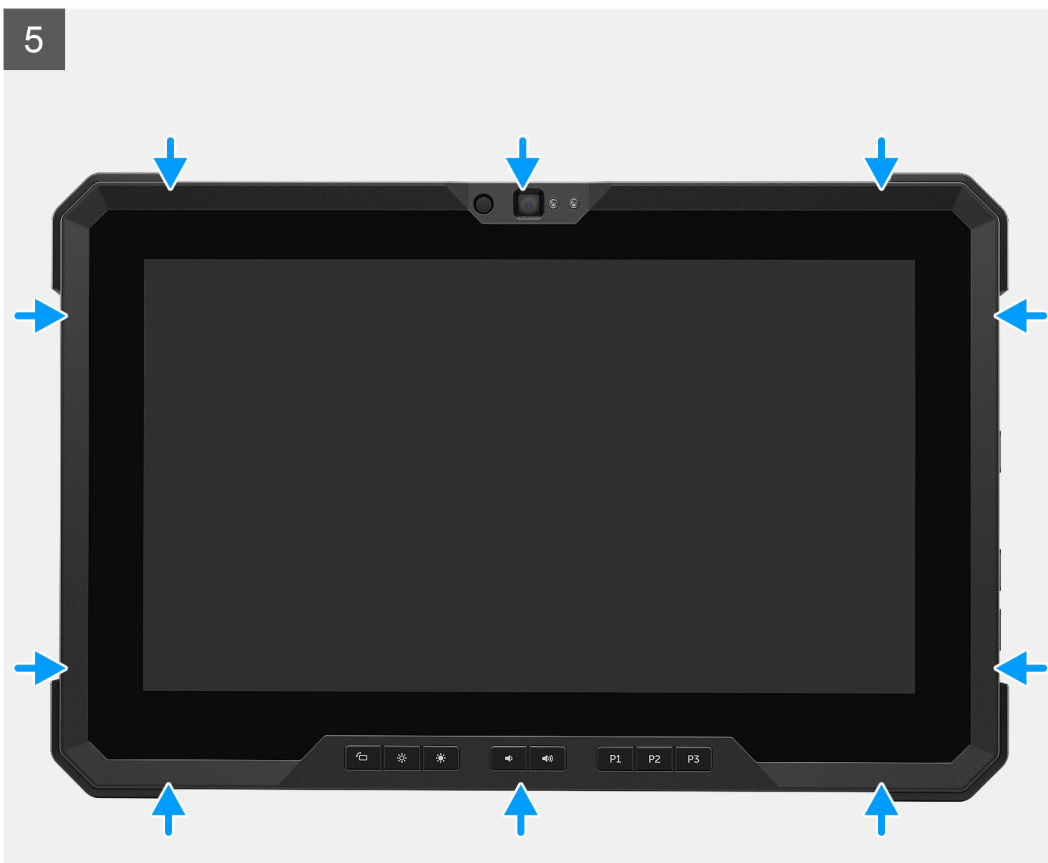

6





19x
M2.5x5



7



Steps

1. Place the LCD panel by less than 90°, use a plastic scribe to connect the eDP cable and close the latch. Secure the connector with the attached adhesive tape that came with the eDP cable.
2. Using a plastic scribe, connect the function key cable to the connector on the system board and close the latch. Secure the connector with new adhesive tape.
3. Using a plastic scribe, connect the touch cable to the connector on the system board and close the latch. Secure the connector with new adhesive tape.
4. Align the LCD panel on the chassis.
5. Press the edges of the display assembly to secure it to the chassis.
6. Flip the tablet.

i **NOTE:** Ensure to place the tablet on a flat surface.

7. Replace the 19 (M2.5x5) screws that secure the display assembly to the chassis.

i **NOTE:** DO NOT force tighten the screws, to avoid damage to the screws thread.

Next steps

1. Install the [batteries](#).
2. Follow the procedure in [after working inside your tablet](#).

Function keys

NOTE: The function key buttons are NOT keyed for correct installation. These keys can be installed with several incorrect combinations which leads to RDs. During a service incident, technicians must note the function keys button layout to ensure that the function keys are installed at their correct location.

Removing the function keys

Prerequisites

1. Follow the procedure in [before working inside your tablet](#).
2. Remove the [batteries](#).
3. Remove the [display assembly](#).

About this task

The figure indicates the location of the function keys and provides a visual representation of the removal procedure.



6x
M2x5

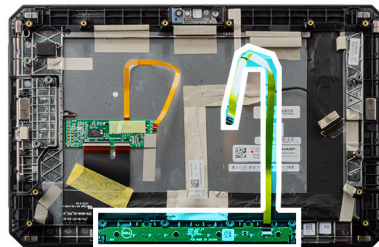

Steps

1. Flip the display assembly.

2. Remove the six (M2x5) screws that secure the function keys board to the display assembly.
3. Lift the function keys board away from the display assembly along with the function keys cable.

Installing the function keys

Prerequisites

If you are replacing a component, remove the existing component before performing the installation procedure.

About this task

The figure indicates the location of the function keys and provides a visual representation of the installation procedure.



6x
M2x5

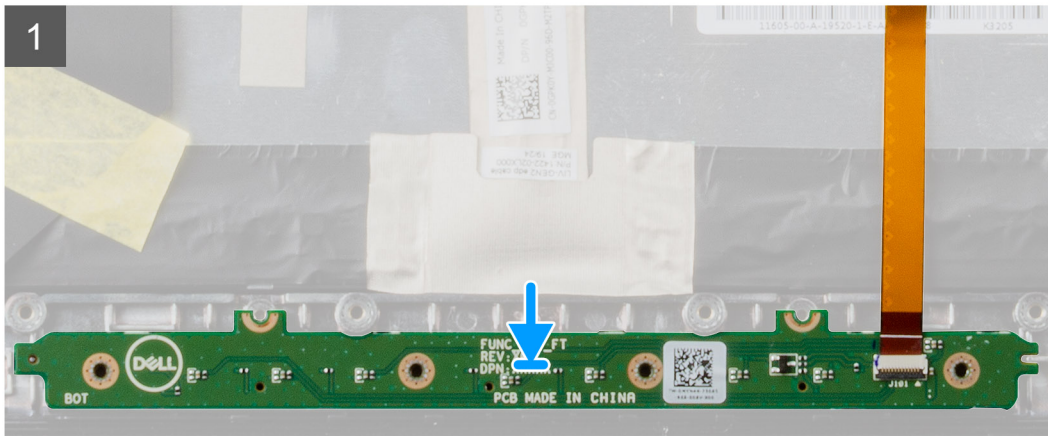
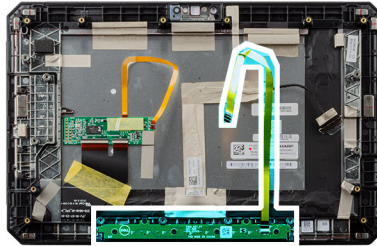

Steps

1. Align and place the function keys board on the display assembly.
2. Replace the six (M2x5) screws that secure the function keys board to the display assembly.

Next steps

1. Install the [display assembly](#).
2. Install the [batteries](#).

3. Follow the procedure in [after working inside your tablet](#).

Heat sink

Removing the SSD heat-sink

Prerequisites

1. Follow the procedure in [before working inside your tablet](#).
2. Remove the [batteries](#).
3. Remove the [display assembly](#).

About this task

The figure indicates the location of the heat sink and provides a visual representation of the removal procedure.

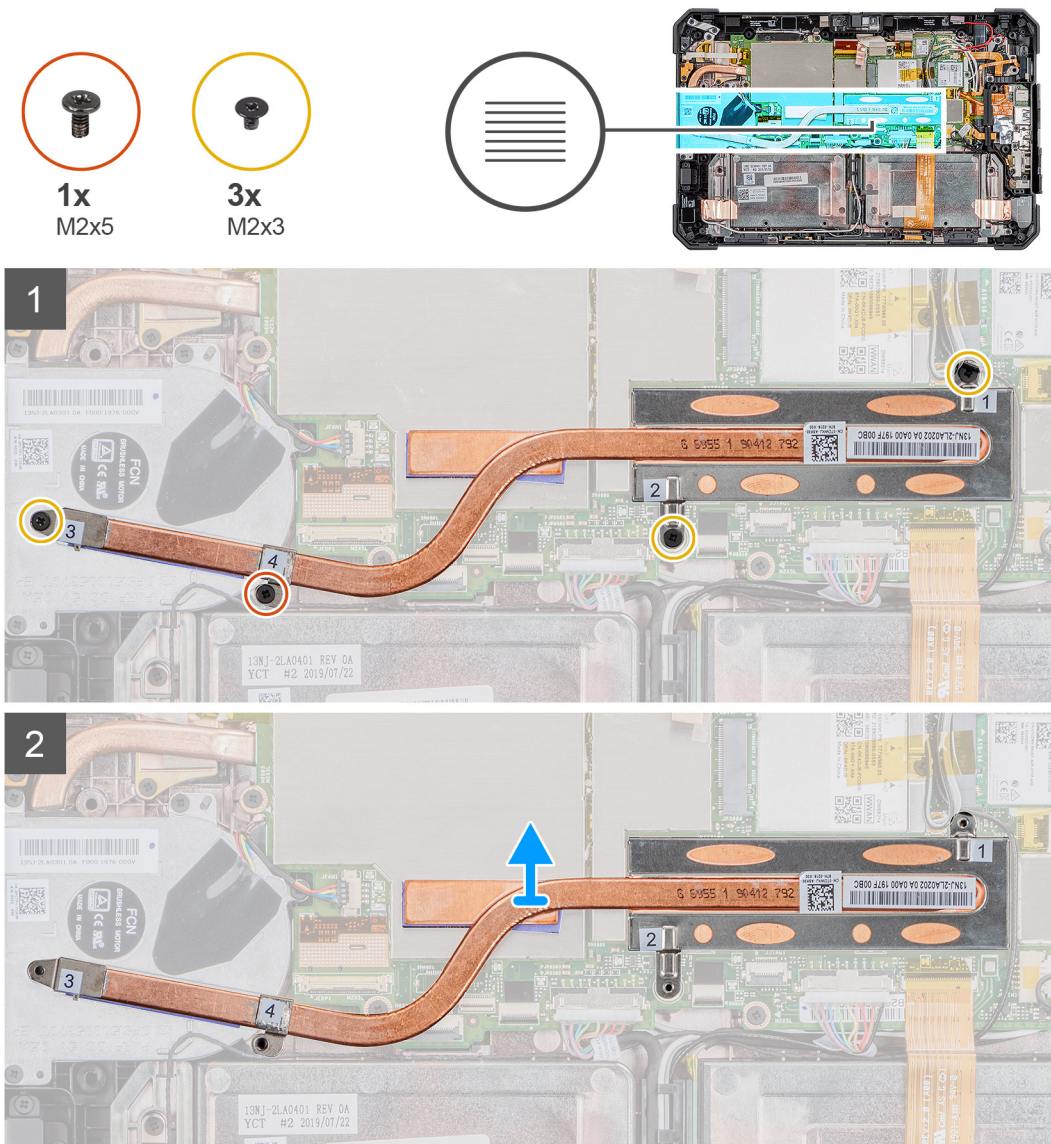

Steps

1. Remove the three (M2X3) screws and M2X5 screw that secure the SSD heat-sink to the system board.

NOTE: Remove the screws in the order of the callout numbers [1,2,3,4] as indicated on the SSD heat sink.

NOTE: Ensure not to bend the heatsink pipe while removing the heatsink from the SSD. Do not remove the heatsink by pulling on the pipe. Carefully pry the cover from the SSD using a plastic scribe.

2. Lift the heat-sink away from the system board.

Installing the SSD heat-sink

Prerequisites

If you are replacing a component, remove the existing component before performing the installation procedure.

About this task

The figure indicates the location of the SSD heat-sink and provides a visual representation of the installation procedure.

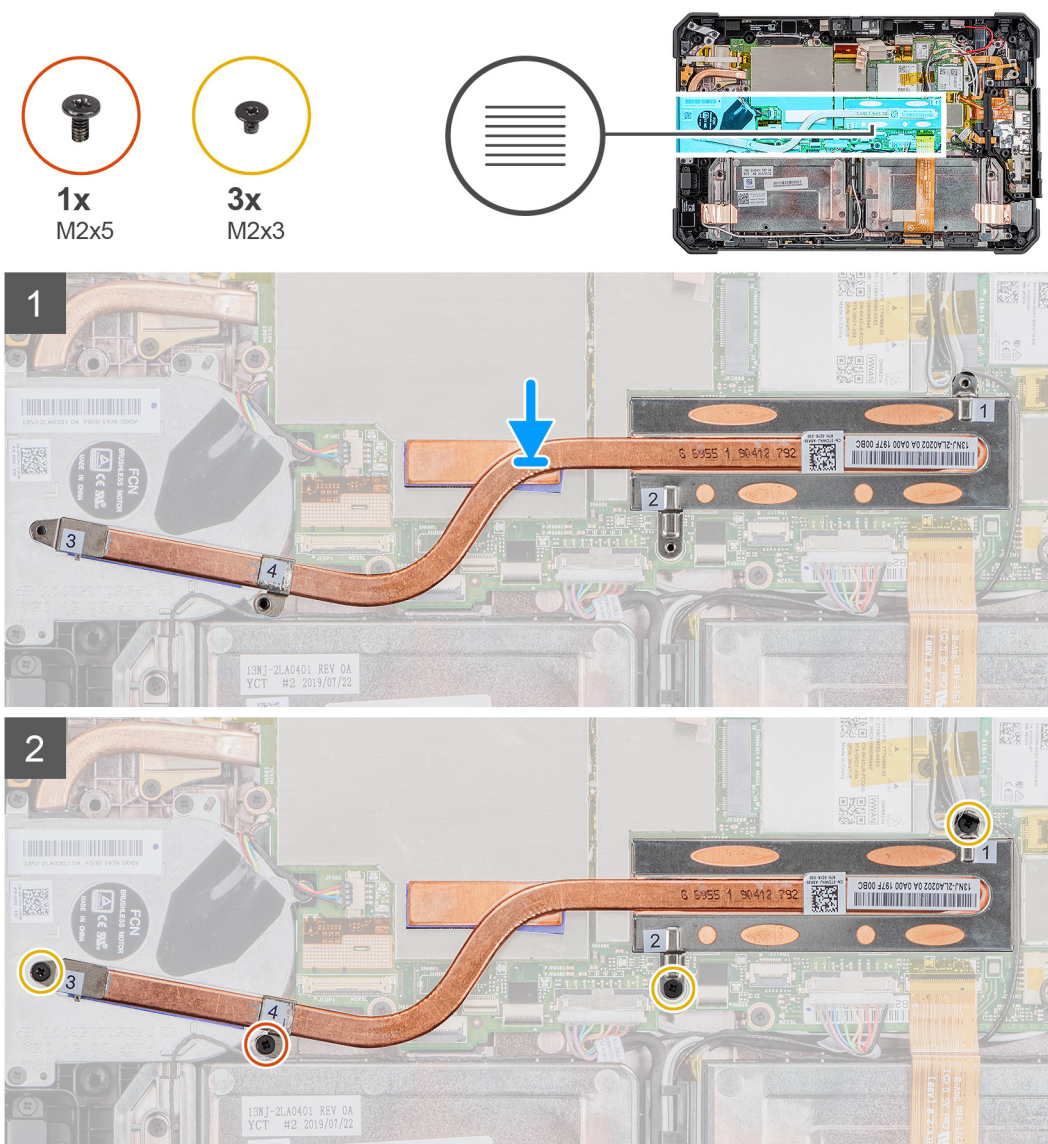

Steps

1. Align the screws on the SSD heat-sink with the screw holes on the system board.
2. Tighten the four captive screws to secure the SSD heat-sink to the system board.

NOTE: Replace the screws in the order indicated on the heat-sink.

Next steps

1. Install the [display assembly](#).
2. Install the [batteries](#).
3. Follow the procedure in [after working inside your tablet](#).

System fan

Removing the system fan

Prerequisites

1. Follow the procedure in [before working inside your tablet](#).
2. Remove the [batteries](#).
3. Remove the [display assembly](#).
4. Remove the [SSD heat-sink](#).

About this task

The figure indicates the location of the system fan and provides a visual representation of the removal procedure.



Steps

1. Unroute the cable from the routing guide on the system fan.
2. Disconnect the system fan cable from the connector on the system board.
3. Remove the four (M2x5) screws that secure the system fan to the system board.
4. Lift the system fan off the system board.

Installing the system fan

Prerequisites

If you are replacing a component, remove the existing component before performing the installation procedure.

About this task

The figure indicates the location of the system fan and provides a visual representation of the installation procedure.

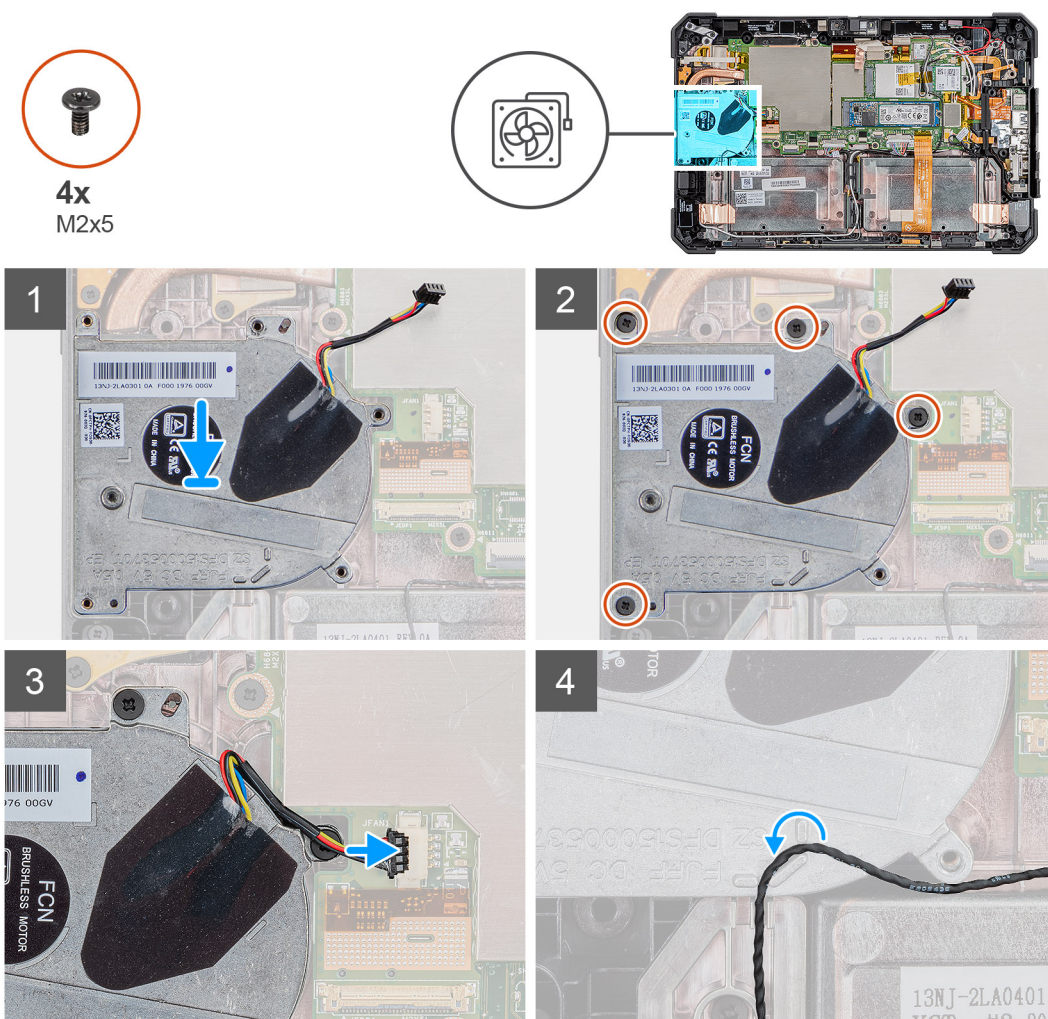

Steps

1. Align the screws on the system fan with the screw holes on the system board.
2. Replace the four (M2x5) screws to secure the system fan to the chassis.
3. Connect the system fan cable to the connector on the system board.
4. Route the system fan cable through the routing guide on the system fan.

Next steps

1. Install the [SSD heat-sink](#).
2. Install the [display assembly](#).
3. Install the [batteries](#).
4. Follow the procedure in [after working inside your tablet](#).

Solid-state drive

Removing the M.2 2230 solid-state drive

Prerequisites

1. Follow the procedure in [before working inside your tablet](#).
2. Remove the [batteries](#).
3. Remove the [display assembly](#).
4. Remove the [heat-sink](#).

About this task

The figure indicates the location of the M.2 2230 solid-state drive and provides a visual representation of the removal procedure.

Steps

1. Remove the (M2x3) screw that secures the solid-state drive to the system board.
2. Slide and remove the solid-state drive from the solid-state drive slot on the system board.

Removing the M.2 2280 solid-state drive

Prerequisites

1. Follow the procedure in [before working inside your tablet](#).
2. Remove the [batteries](#).
3. Remove the [display assembly](#).
4. Remove the [SSD heat-sink](#).

About this task

The figure indicates the location of the solid-state drive and provides a visual representation of the removal procedure.



1x
M2x3

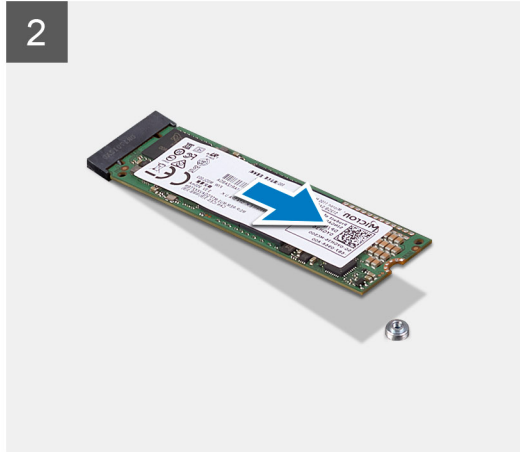
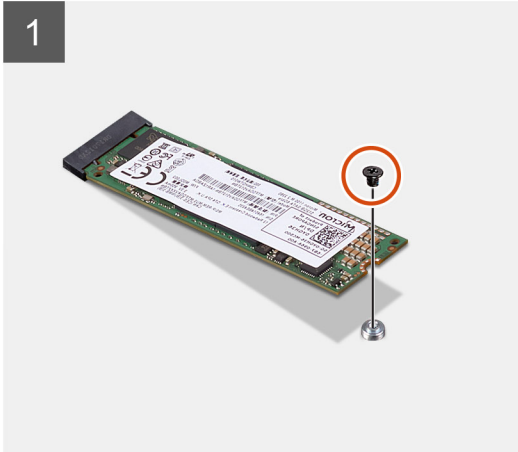
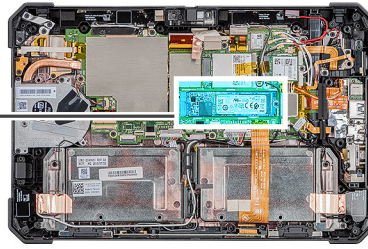

Steps

1. Remove the (M2x3) screw that secures the solid-state drive to the system board.
2. Slide and remove the solid-state drive from the solid-state drive slot on the system board.

Installing M.2 2230 solid-state drive

Prerequisites

If you are replacing a component, remove the existing component before performing the installation procedure.

About this task

The following image indicates the location of the M.2 2230 solid-state drive and provides a visual representation of the installation procedure:

Steps

1. Align the notch on the solid-state drive with the tab on the solid-state drive slot.
2. Replace the screw (M2x3) that secures the solid-state drive module to the system board.

Next steps

1. Install the [heat-sink](#).
2. Install the [display assembly](#).
3. Install the [batteries](#).
4. Follow the procedure in [after working inside your tablet](#).

Installing the M.2 2280 solid-state drive

Prerequisites

If you are replacing a component, remove the existing component before performing the installation procedure.

About this task

The following image indicates the location of the M.2 2280 solid-state drive and provides a visual representation of the installation procedure:

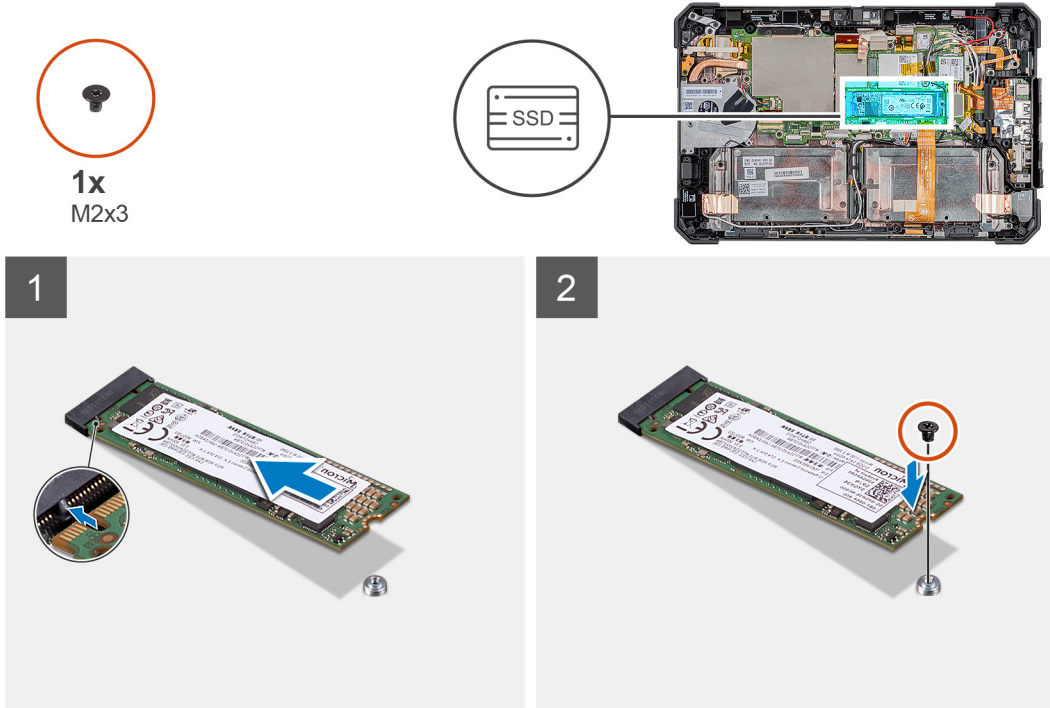

Steps

1. Align the notch on the solid-state drive with the tab on the solid-state drive slot.
2. Replace the screw (M2x3) that secures the solid-state drive module to the system board.

Next steps

1. Install the [heat-sink](#).
2. Install the [display assembly](#).
3. Install the [batteries](#).
4. Follow the procedure in [after working inside your tablet](#).

WLAN card

Removing the WLAN card

Prerequisites

1. Follow the procedure in [before working inside your tablet](#).
2. Remove the [batteries](#).
3. Remove the [display assembly](#).

About this task

The figure indicates the location of the WLAN card and provides a visual representation of the removal procedure.



1x
M2x3

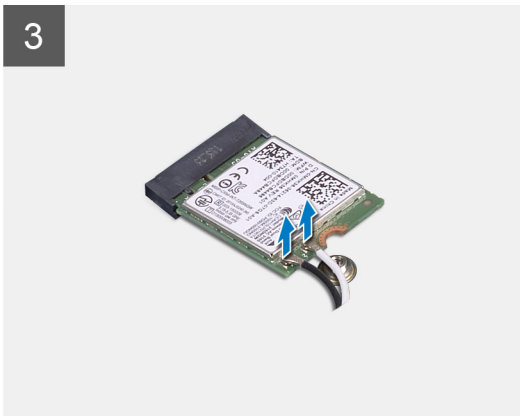
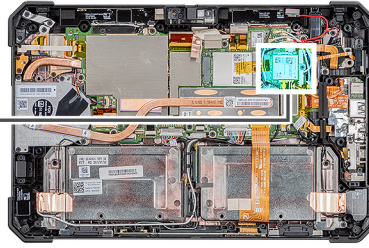

Steps

1. Remove the screw (M2x3) that secures the WLAN card bracket to the WLAN card.
2. Remove the WLAN card bracket from the WLAN card.
3. Disconnect the antenna cables from the WLAN card.
4. Slide and remove the WLAN card from the WLAN card slot.

Installing the WLAN card

Prerequisites

If you are replacing a component, remove the existing component before performing the installation procedure.

About this task

The figure indicates the location of the WLAN card and provides a visual representation of the installation procedure.



1x
M2x3

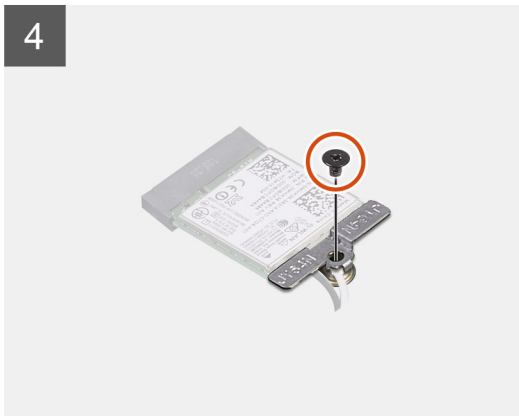
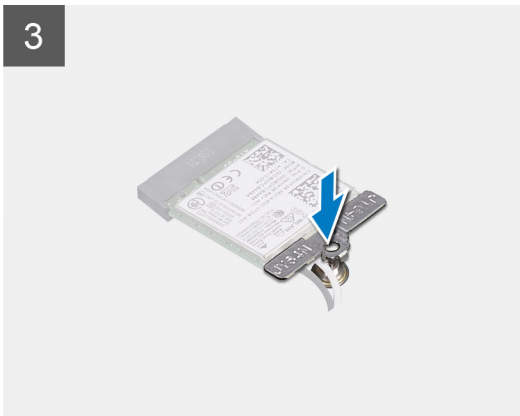
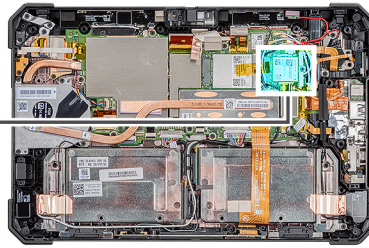

Steps

1. Slide the wireless card at an angle into the wireless card slot.
2. Connect the antenna cables to the WLAN card. The following table provides the antenna-cable color scheme for the WLAN card that supports your tablet.

Table 2. Connectors on the wireless card

Antenna	Cable Color
Main (white triangle)	White
Auxiliary (black triangle)	Black

3. Place the WLAN card bracket on the WLAN card.
4. Replace the screw (M2x3) to secure the WLAN card bracket to the WLAN card.

Next steps

1. Install the [display assembly](#).
2. Install the [batteries](#).
3. Follow the procedure in [after working inside your tablet](#).

WWAN card

Removing the WWAN card

Prerequisites

1. Follow the procedure in [before working inside your tablet](#).
2. Remove the [batteries](#).
3. Remove the [display assembly](#).

About this task

The figure indicates the location of the WWAN card and provides a visual representation of the removal procedure.

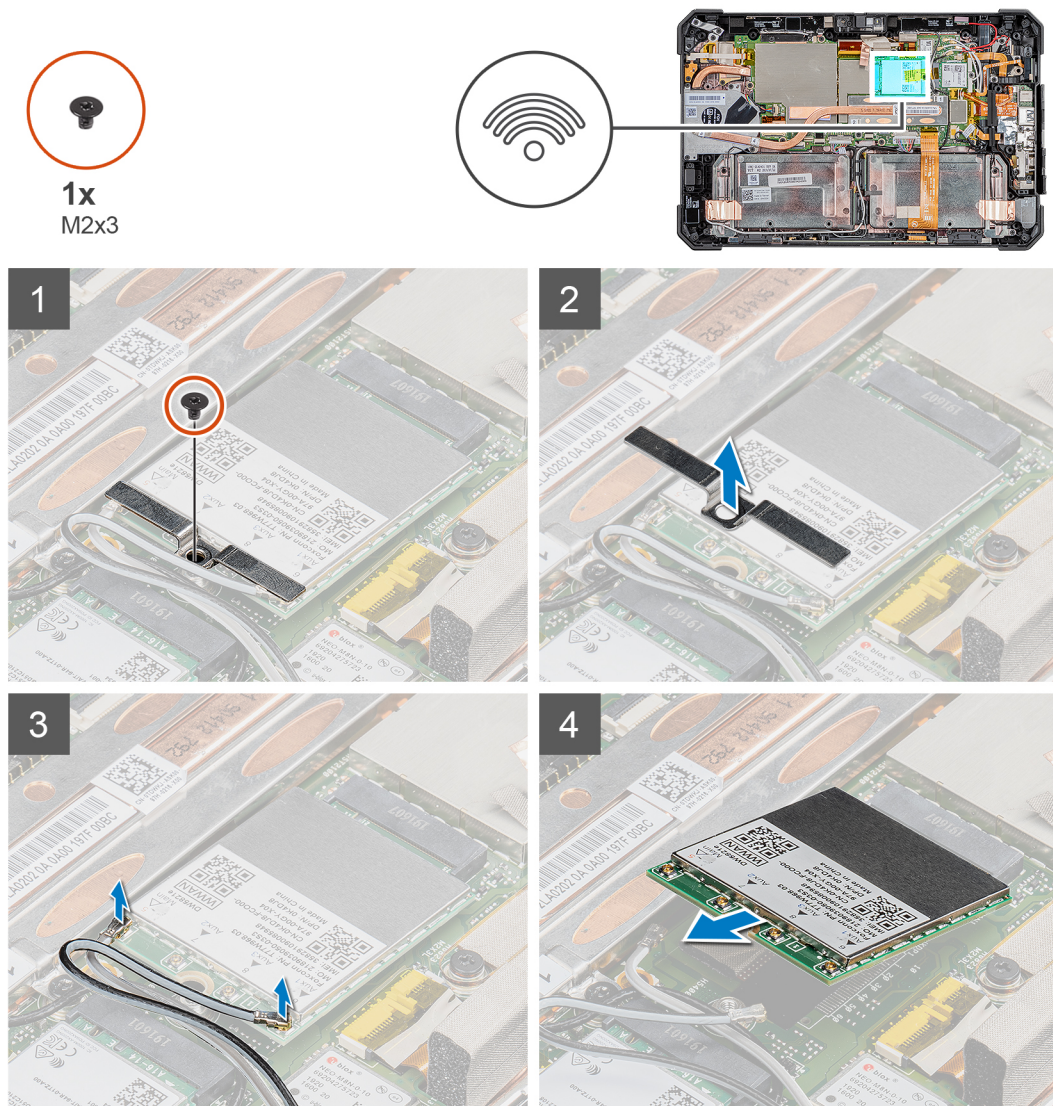

Steps

1. Remove the screw (M2x3) that secures the WWAN card bracket to the WWAN card.
2. Remove the WWAN card bracket from the WWAN card.
3. Disconnect the antenna cables from the WWAN card.
4. Slide and remove the WWAN card from the WWAN card slot.

Installing the WWAN card

Prerequisites

If you are replacing a component, remove the existing component before performing the installation procedure.

About this task

The figure indicates the location of the WWAN card and provides a visual representation of the installation procedure.



Steps

1. Slide the WWAN card at an angle into the WWAN card slot.
2. Connect the antenna cables to the WWAN card. The following table provides the antenna-cable color scheme for the WWAN card that supports your tablet.

Table 3. Connectors on the wireless card

Antenna	Cable Color
Main (white triangle)	White
Auxiliary (black triangle)	Black

3. Place the WWAN card bracket on the WWAN card.

4. Replace the screw (M2x3) to secure the WWAN card bracket to the WWAN card.

Next steps

1. Install the [display assembly](#).
2. Install the [batteries](#).
3. Follow the procedure in [after working inside your tablet](#).

Microphone

Removing the microphone

Prerequisites

1. Follow the procedure in [before working inside your tablet](#).
2. Remove the [batteries](#).
3. Remove the [display assembly](#).

About this task

The figure indicates the location of the microphone and provides a visual representation of the removal procedure.

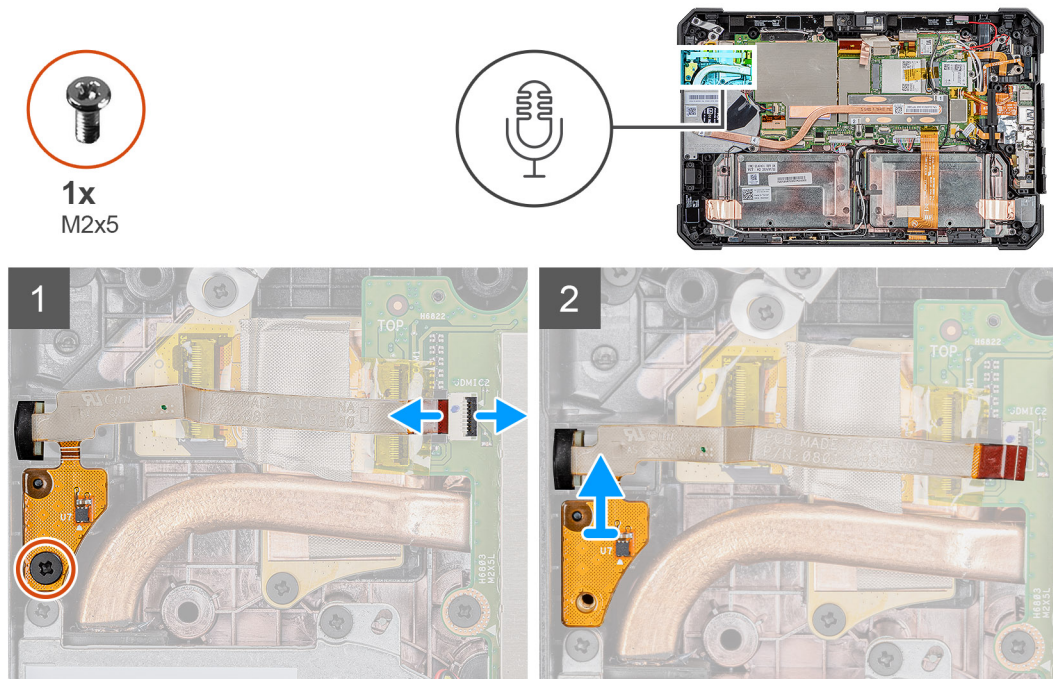

Steps

1. Remove the adhesive tape, open the latch, and disconnect the microphone cable from the connector on the system board. Remove the screw (M2x5) that secures the integrated microphone assembly circuit board to the system board.
2. Lift the microphone cable to expose another screw that holds the microphone bracket in place. Remove the bracket to loosen the microphone assembly.
3. Release the microphone assembly and, lift the microphone from the tablet chassis.

NOTE: NEVER pull the microphone by the cable. In case the circuit board is not released smoothly, push from below the microphone circuit board by a plastic scribe.

Installing the microphone

Prerequisites

If you are replacing a component, remove the existing component before performing the installation procedure.

About this task

The figure indicates the location of the microphone and provides a visual representation of the installation procedure.



1x
M2x5

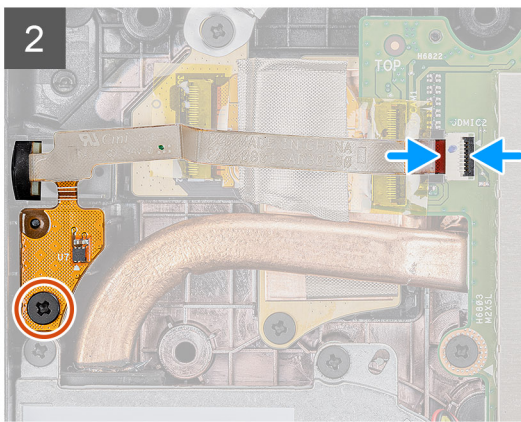
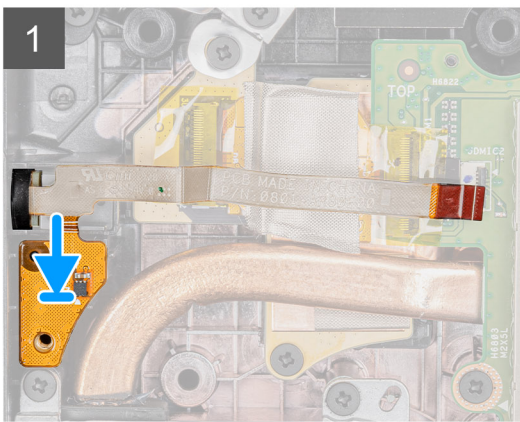
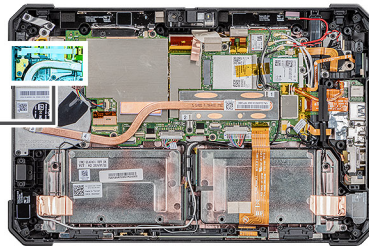

Steps

1. Align the screw hole on the integrated microphone assembly circuit board with the screw hole on the chassis.
2. Insert the microphone and microphone bracket. Replace the screw that holds the microphone bracket in place.
3. Replace the screw (M2x5) that secures the integrated microphone assembly circuit board to the chassis and connect the microphone cable to the connector on the system board. Close the latch to secure the cable.

Next steps

1. Install the [display assembly](#).
2. Install the [batteries](#).
3. Follow the procedure in [after working inside your tablet](#).

Front camera

Removing the front camera

Prerequisites

1. Follow the procedure in [before working inside your tablet](#).
2. Remove the [batteries](#).
3. Remove the [display assembly](#).

About this task

The figure indicates the location of the front camera and provides a visual representation of the removal procedure.



1x
M2x3

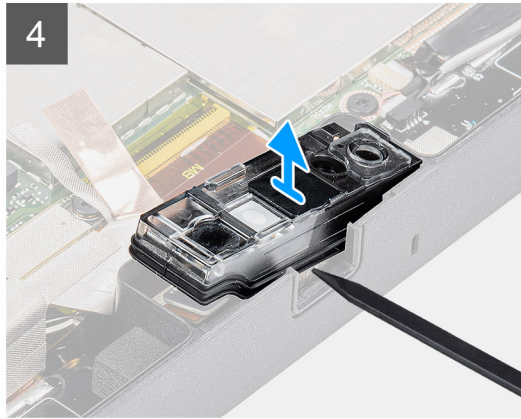
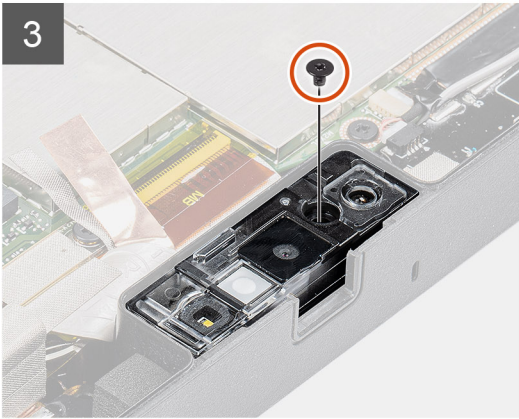
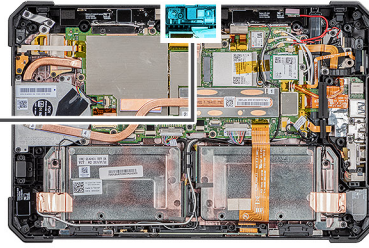

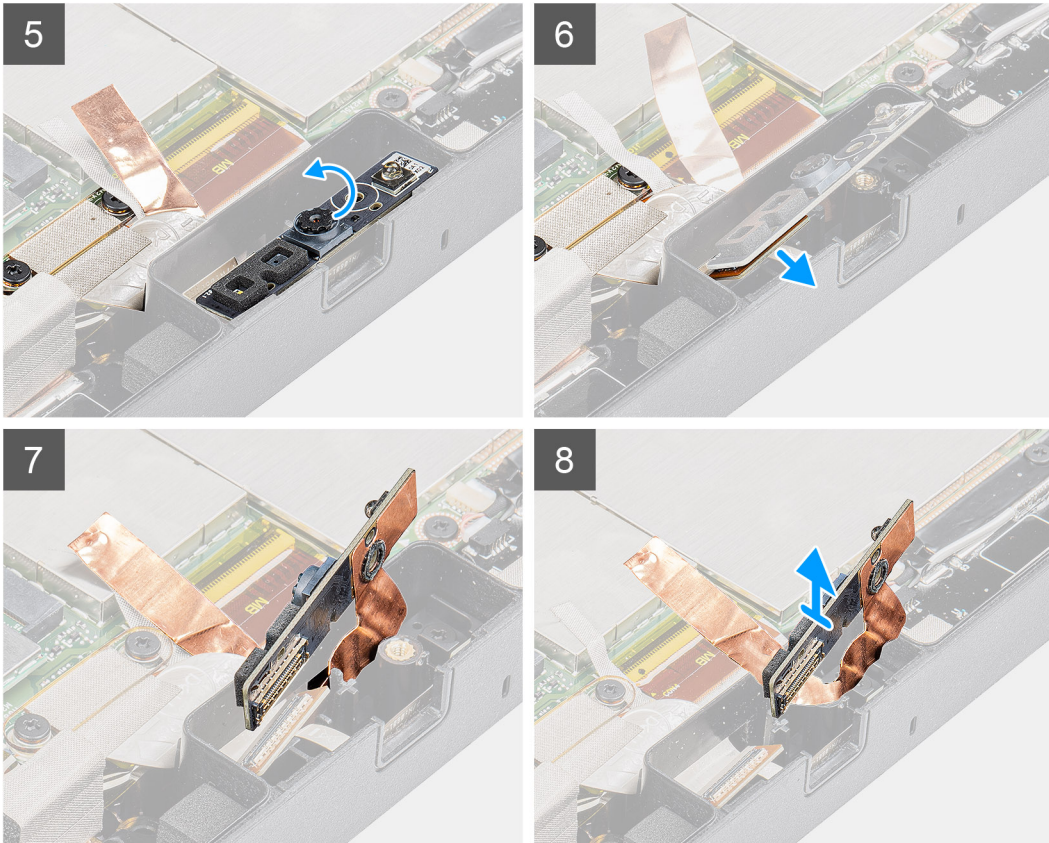

Steps

1. Open the lens cover by sliding the camera shutter towards right.
2. Using a plastic scribe, lift the camera lens shutter.
3. Remove the (M2x3) screw that secures the camera cover on the tablet chassis.
4. Using a plastic scribe, lift the front camera from the tablet chassis.
5. Lift the lens case at the edge to insert the plastic scribe in the gap.
6. Disconnect the camera cable that secures the cable to the system board.
7. Lift the lens case by an angle not more than 35° and push upward to release the camera lens case.
8. Remove the camera circuit board away from the tablet chassis.

Installing the front camera

Prerequisites

If you are replacing a component, remove the existing component before performing the installation procedure.

About this task

The figure indicates the location of the front camera and provides a visual representation of the installation procedure.



1x
M2x3

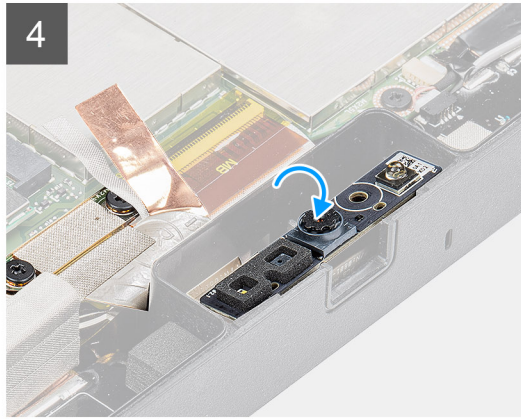
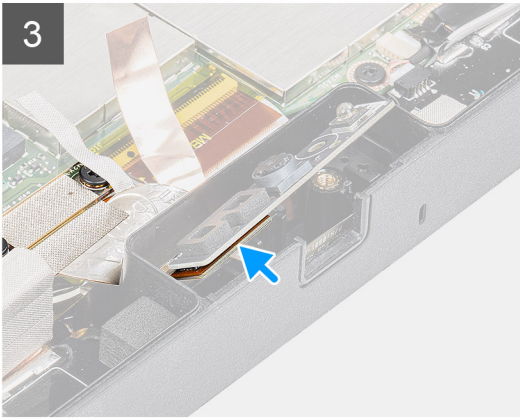
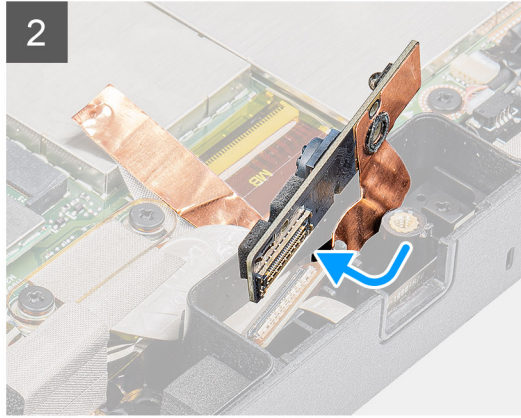
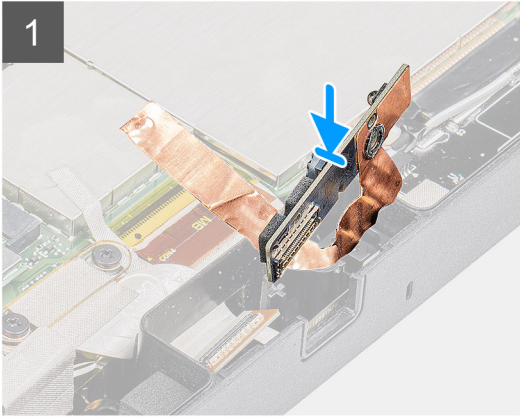
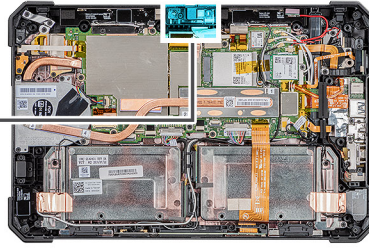

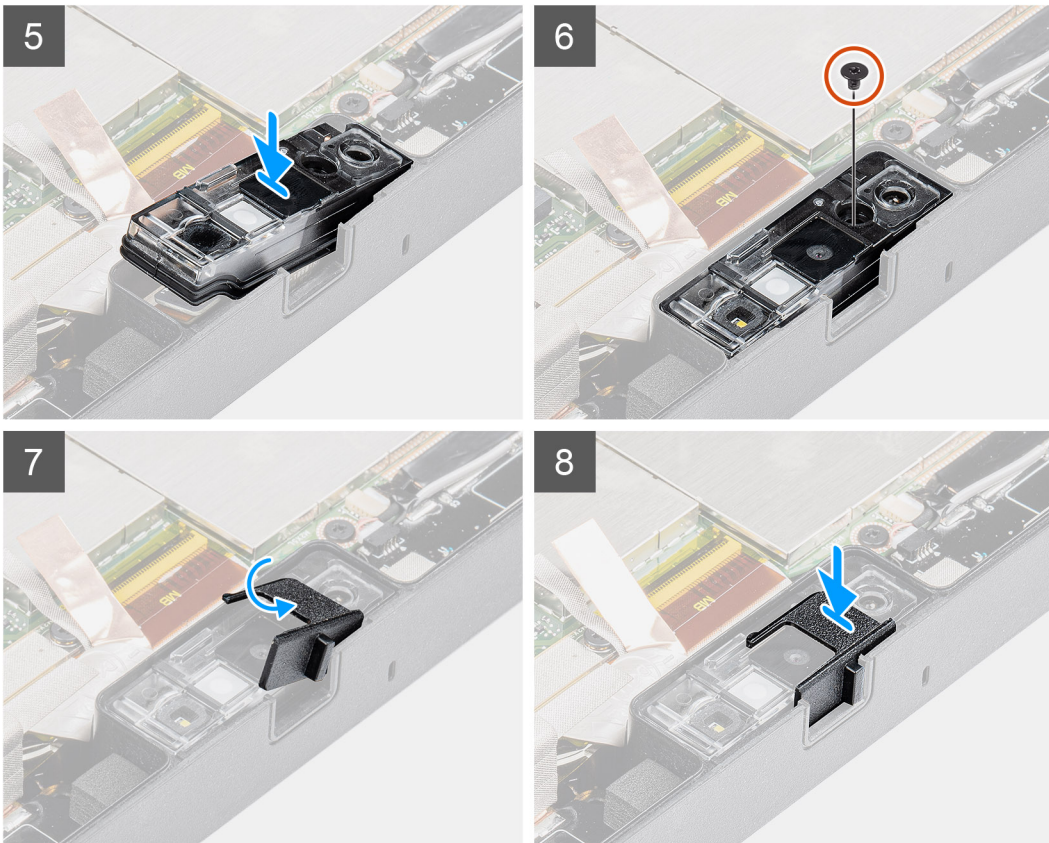

Steps

1. Align the front camera circuit board over the camera slot.
 - i** **NOTE:** Opposite side of the camera circuit board is placed to connect cable in the connector.
2. Connect the front camera cable and plug in the cable to the connector.
3. Flip the front camera circuit board.
4. Align front camera circuit board with screw hole.
5. Place the camera lens case to the camera placeholder.
6. Replace the screw (M2x3) to secure the front camera circuit board on the tablet chassis.
7. Slide the lens shutter in the lens channel and push towards left.

Next steps

1. Install the [display assembly](#).
2. Install the [batteries](#).
3. Follow the procedure in [after working inside your tablet](#).

Coin-cell battery

Removing the coin-cell battery

Prerequisites

1. Follow the procedure in [before working inside your tablet](#).
2. Remove the [batteries](#).
3. Remove the [display assembly](#).

NOTE: Removing the coin-cell battery resets the BIOS setup programs settings to default. It is recommended that you note the BIOS setup programs settings before removing the coin-cell battery.

About this task

The figure indicates the location of the coin-cell battery and provides a visual representation of the removal procedure.

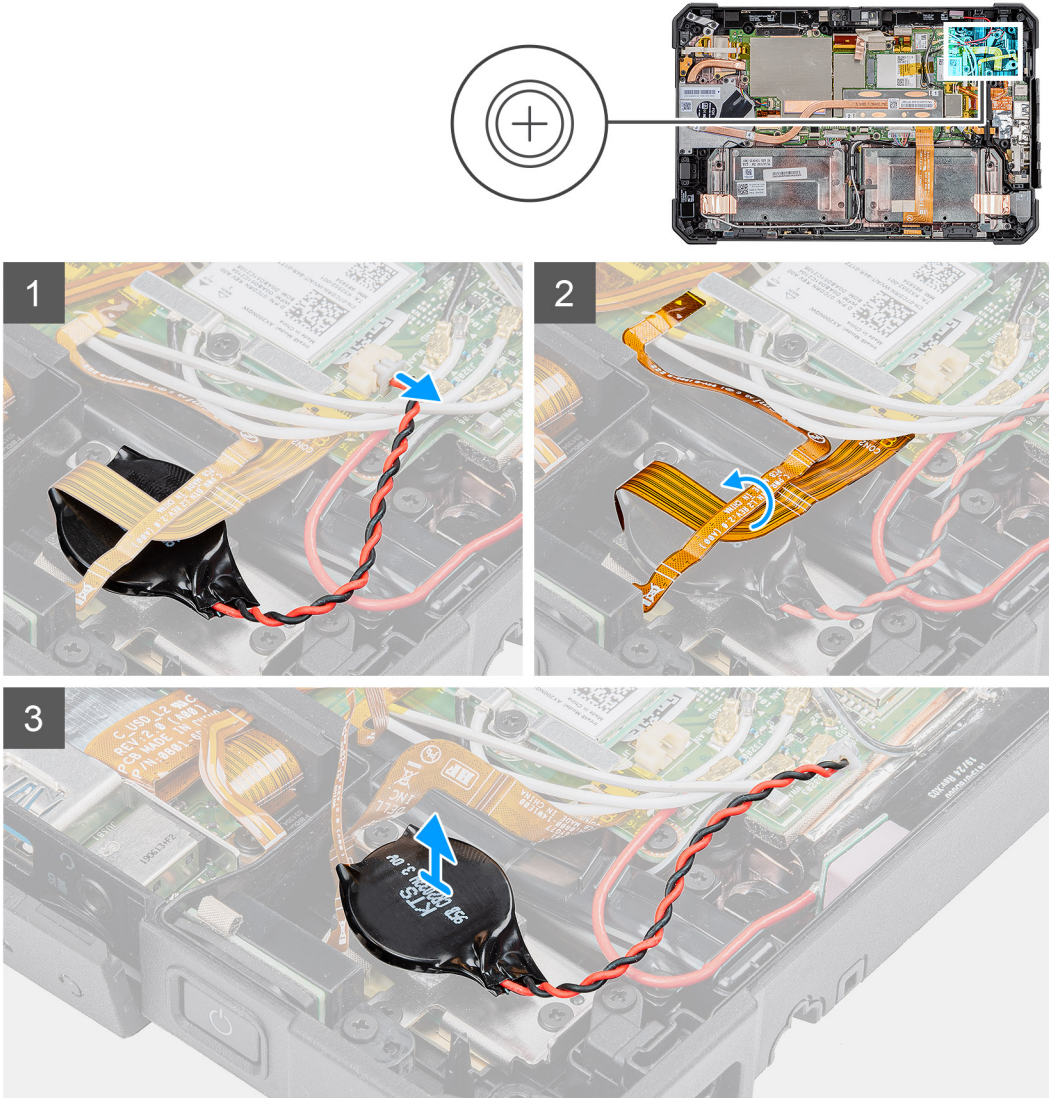

Steps

1. Disconnect the coin-cell battery cable from the system board.
2. Move the fingerprint reader cable and microSD card cable over the coin-cell battery.
3. Peel the coin-cell battery off the system board.

Installing the coin-cell battery

Prerequisites

If you are replacing a component, remove the existing component before performing the installation procedure.

About this task

The figure indicates the location of the coin-cell battery and provides a visual representation of the installation procedure.

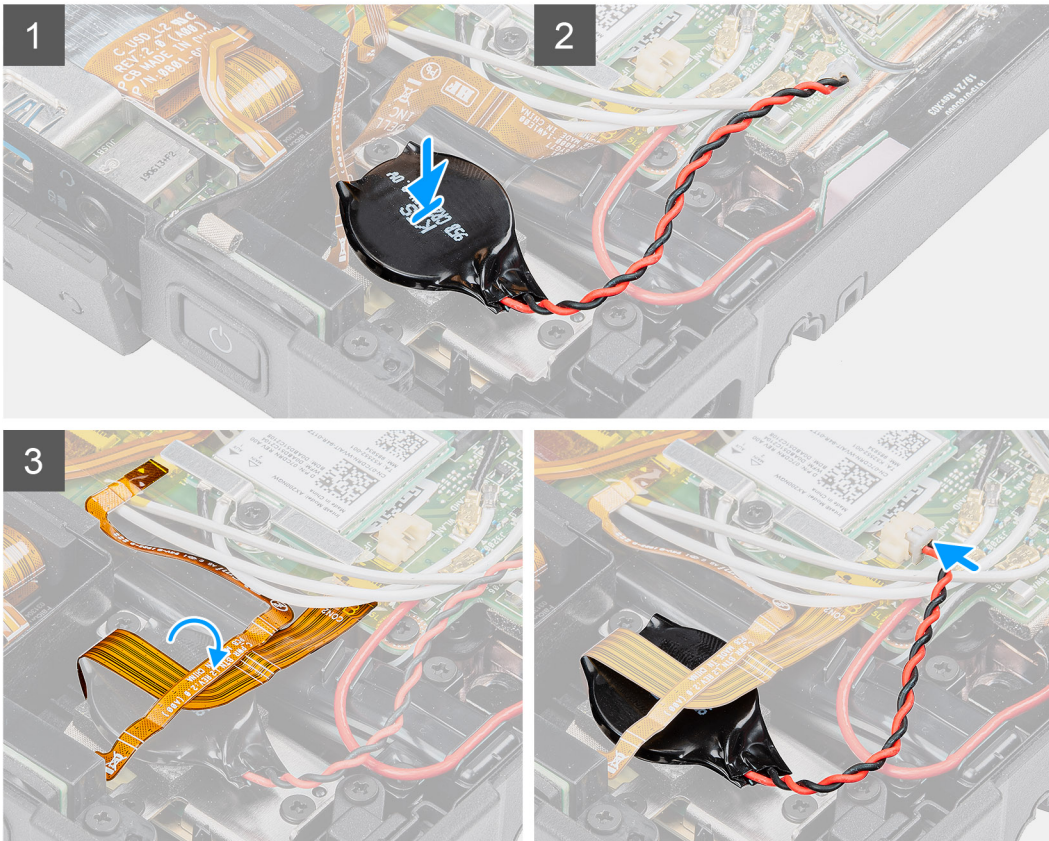
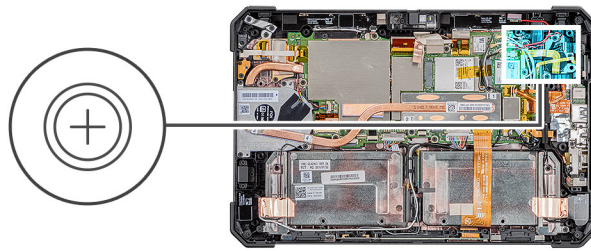

Steps

1. Adhere the coin-cell battery to the slot on the system board.
2. Place the fingerprint cable and microSD card cable on the coin-cell battery.
3. Connect the coin-cell battery cable to the connector on the system board.

Next steps

1. Install the [display assembly](#).
2. Install the [batteries](#).
3. Follow the procedure in [after working inside your tablet](#).

System board

Removing the system board

Prerequisites

1. Follow the procedure in [before working inside your tablet](#).
2. Remove the [batteries](#).
3. Remove the [display assembly](#).

4. Remove the [SSD heat-sink](#).
5. Remove the [system fan](#).
6. Remove the [solid-state drive](#).
7. Remove the [WLAN](#).
8. Remove the [WWAN](#).

About this task

The figure indicates the location of the system board and provides a visual representation of the removal procedure.

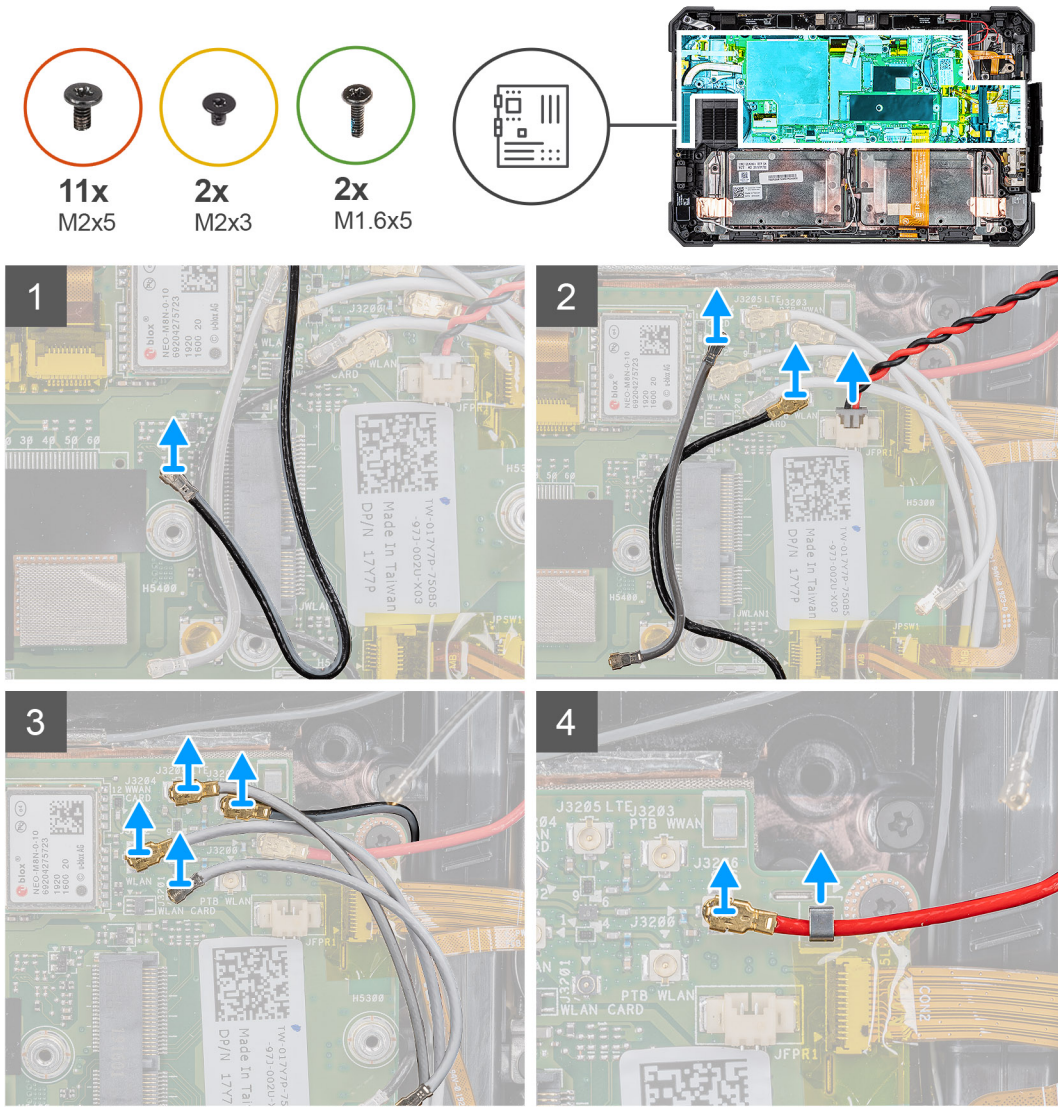

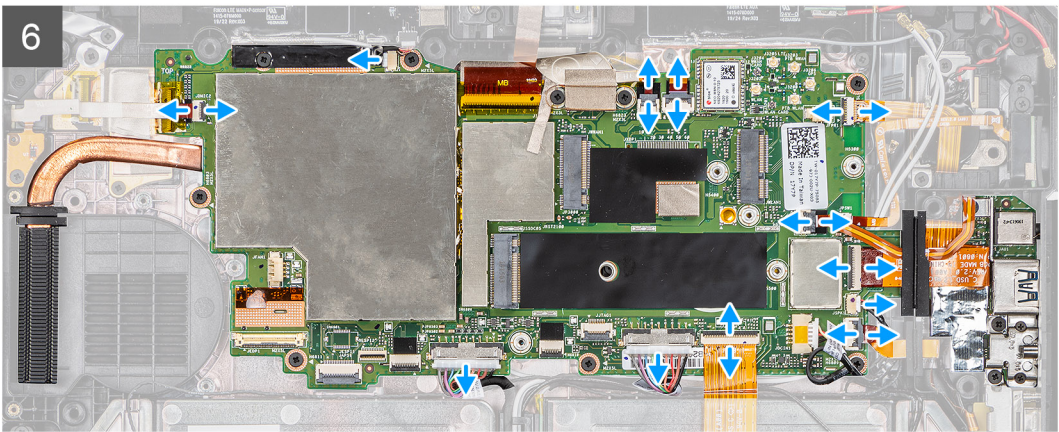
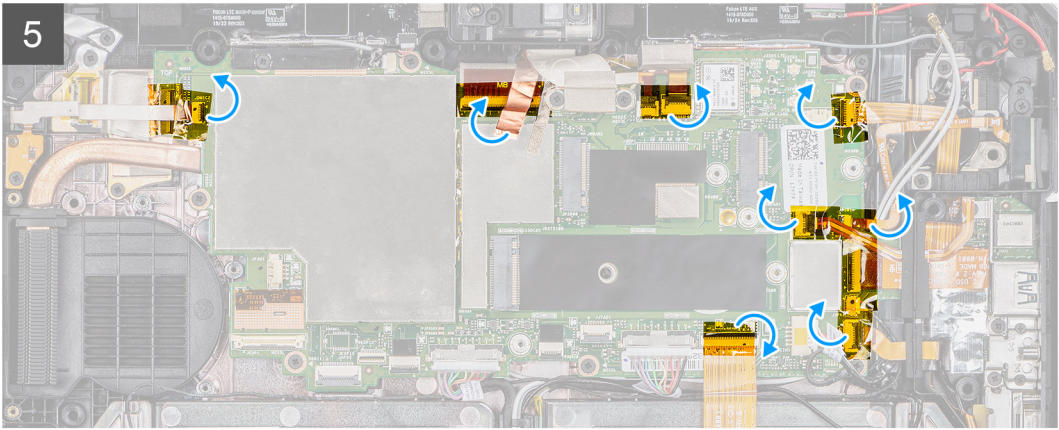

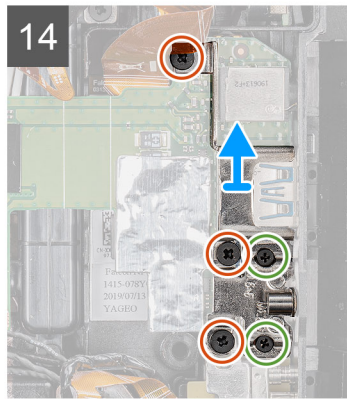
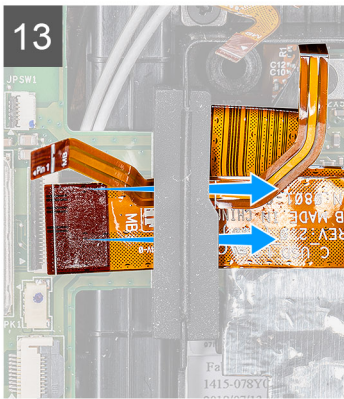
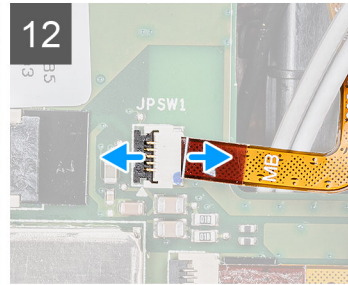
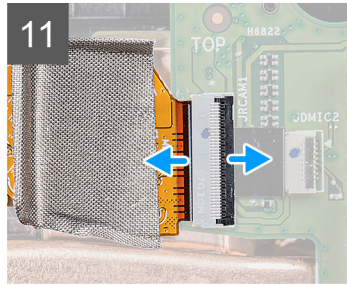
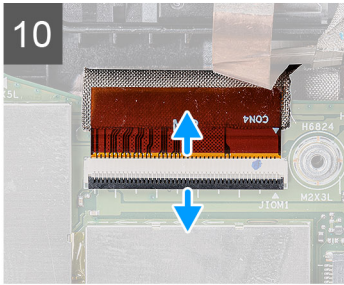
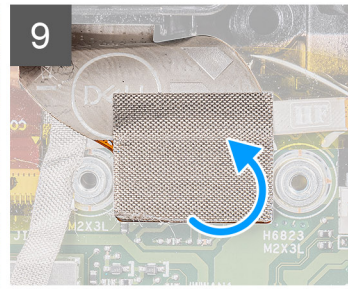
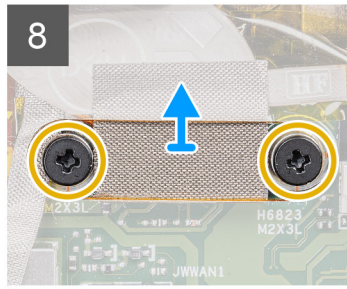
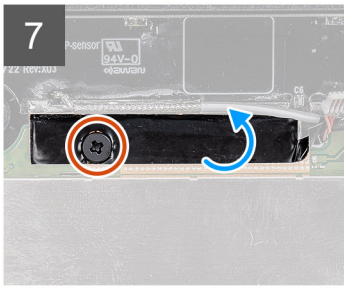

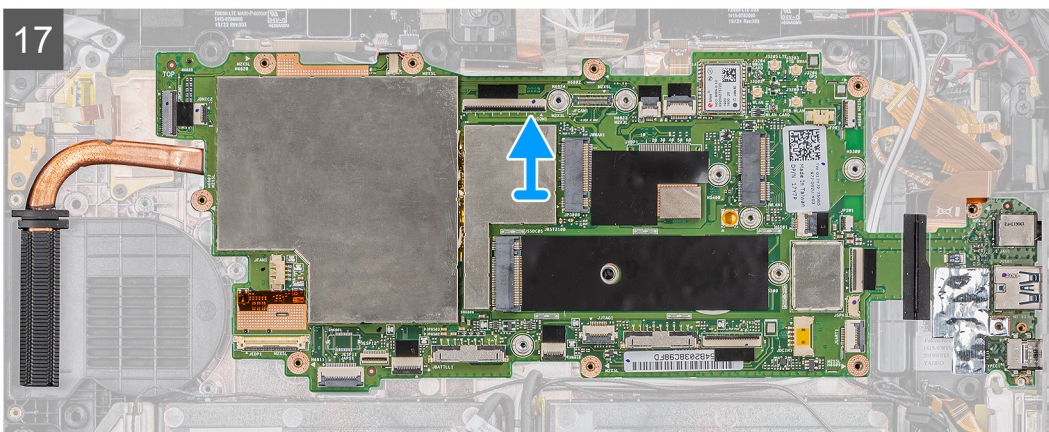
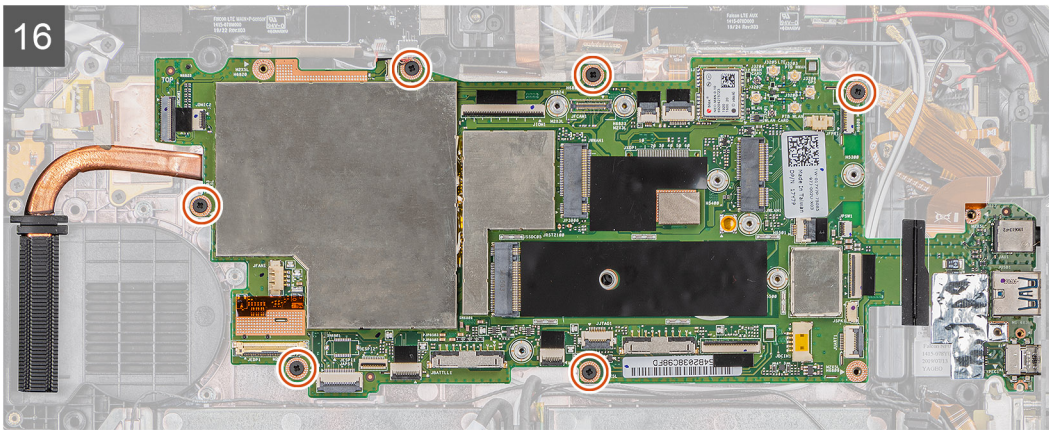

Steps

1. Disconnect the antenna cable from the system board.
2. Disconnect the radio antenna cables and coin-cell battery cable from the system board.
3. Remove the antenna cable from the clip, and disconnect the antenna cables from the system board.
4. Unroute the GPS cable from the routing channel and disconnect it from the system board.
5. Peel the adhesive tapes off the connectors from the system board.
6. Disconnect the following cables from their connector on the system board (L-R): microphone board, LTE main+ p-sensor, mic, smartcard, Fingerprint reader, microSD card, NFC, Mini serial, speaker, pogo connector, right battery, and left battery from the system board.

i NOTE: Carefully slide the microSD cable and NFC cable out from the rubber grommet. Ensure that the pull tab of the FPC cables is not stuck under the rubber grommet. The FPC cables may get damaged, when they are forcefully slid out when their pull tabs are still stuck under the rubber grommet.
7. Remove the screw (M2x5) that secures the adhesive tape, and peel the adhesive tape off the system board.
8. Remove the two (M2x3) screws that secure the camera MIPI plate to the system board.
9. Peel the conductive cloth that secures the camera MIPI plate on the system board.
10. Lift the latch, and disconnect the OpExpansion module pogo connector cable from the system board.
11. Lift the latch, and disconnect the rear camera flexible flat cable (FFC) from the system board.
12. Lift the latch, and disconnect the power button cable from the system board.
13. Slide and remove the microSD cable and NFC cable under the grommet.
14. Remove the three (M2x5) screws and two (M1.6x5) screws to remove the bracket that secures the system board to the tablet chassis.
15. Disconnect the power adapter cable and remove the (M2x5) screw that secures the system board to the tablet chassis.
16. Remove the six (M2x5) screws that secure the system board to the tablet chassis.
17. Lift the system board away from the tablet chassis.

Installing the system board

Prerequisites

If you are replacing a component, remove the existing component before performing the installation procedure.

About this task

The figure indicates the location of the system board and provides a visual representation of the installation procedure.

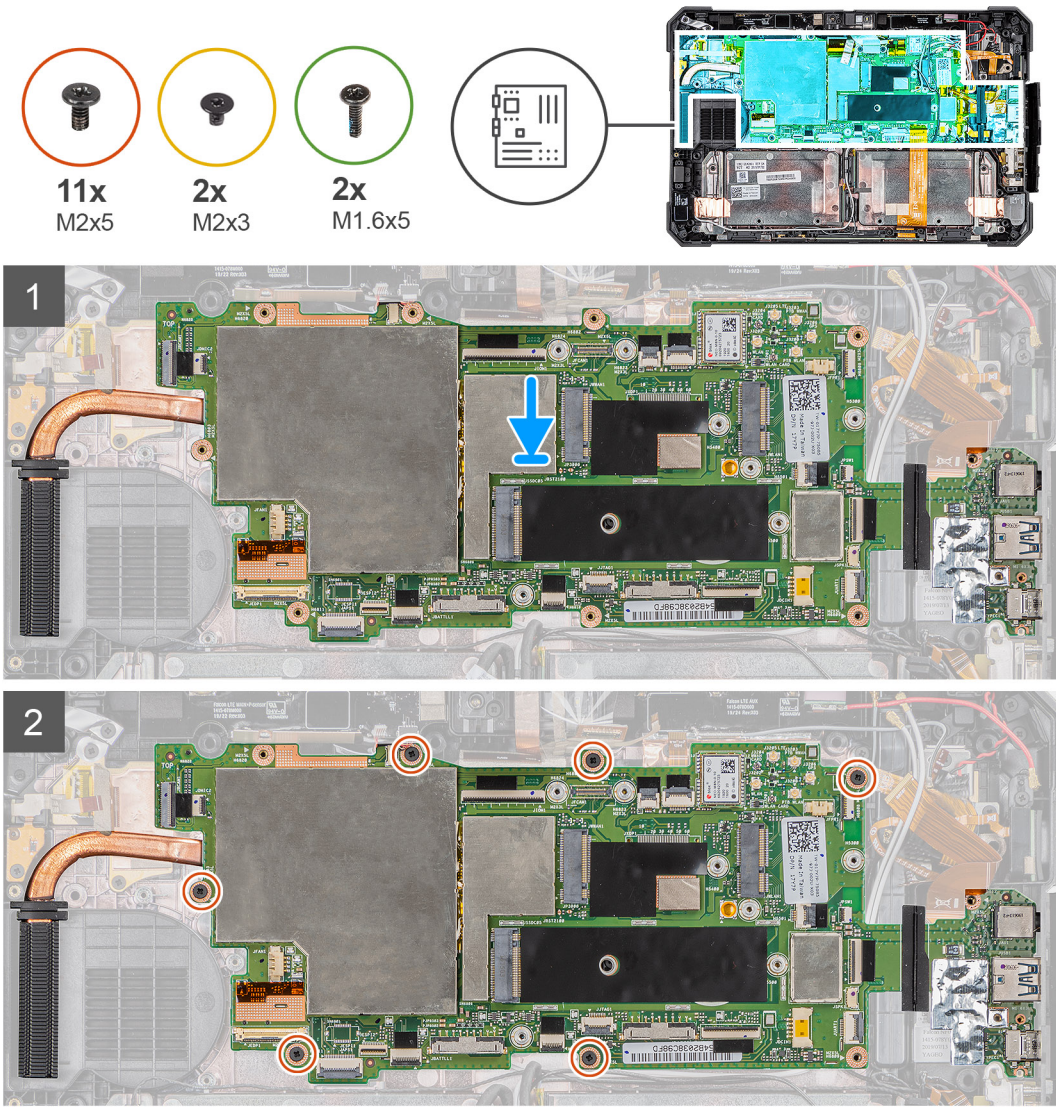

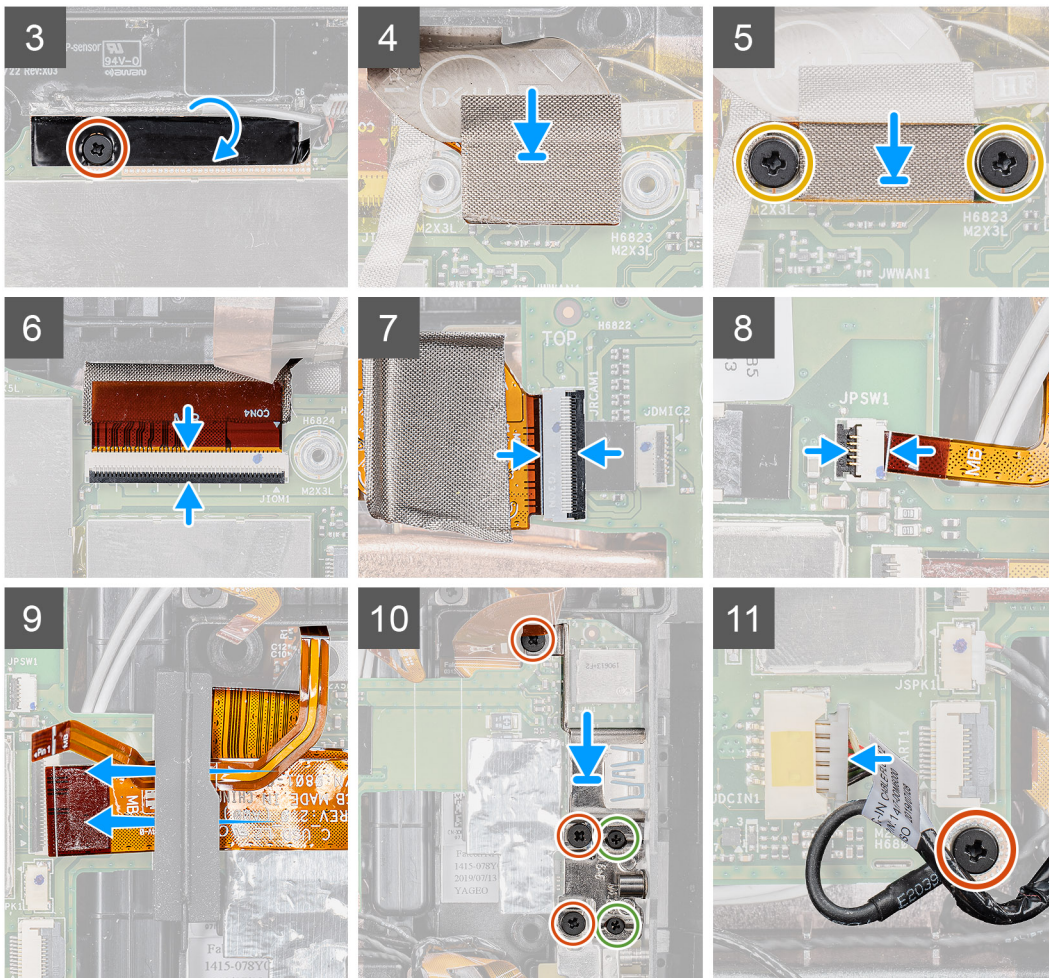

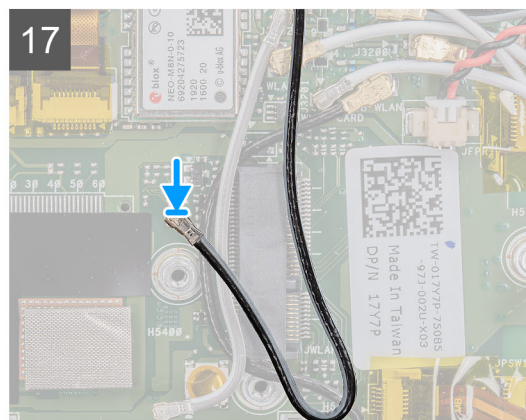
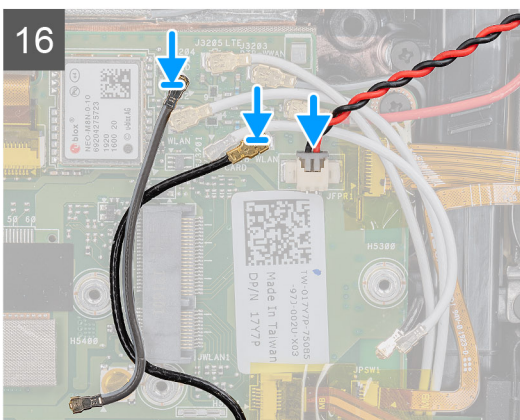
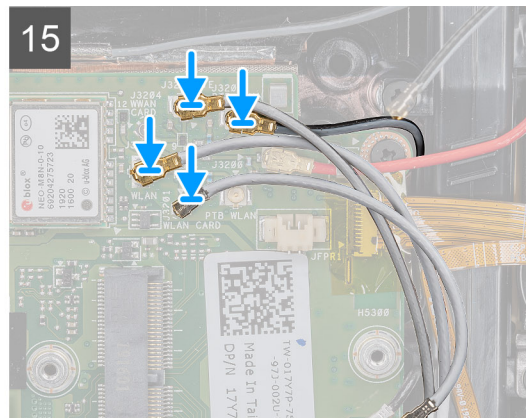
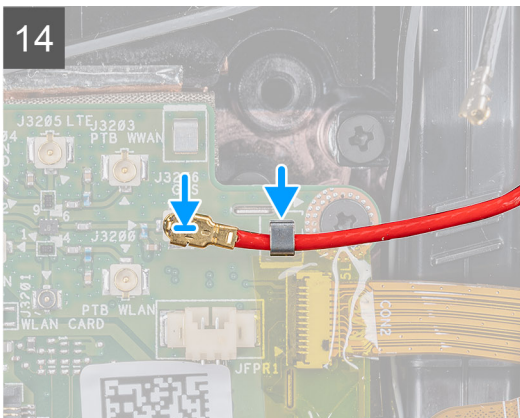
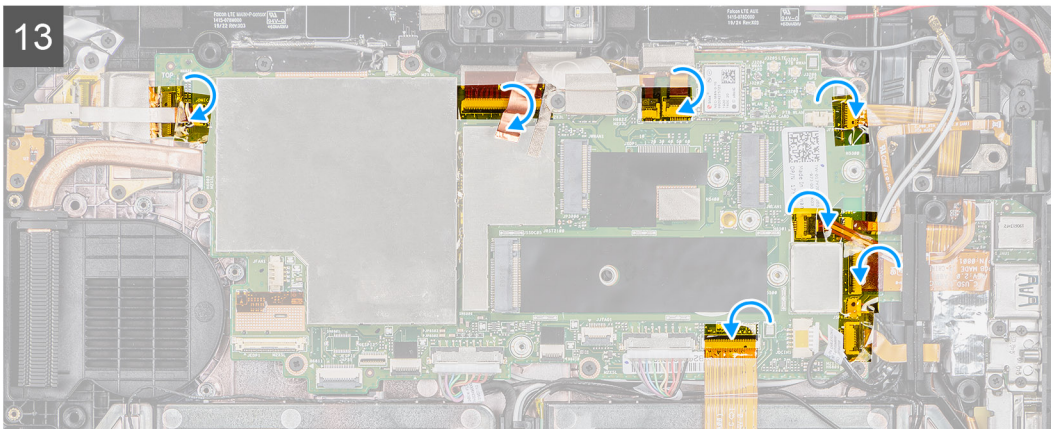
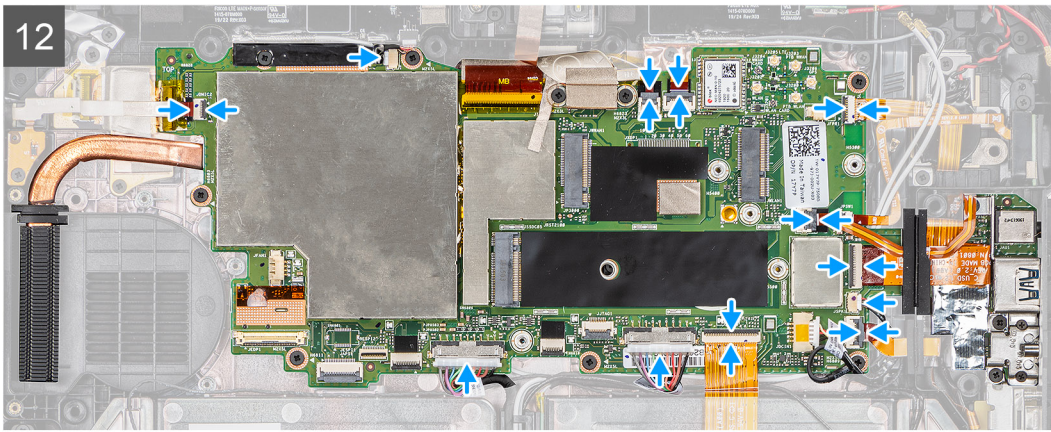

Steps

1. Place the system board on the tablet chassis.

2. Replace the six (M2x5) screws that secure the system board to the tablet chassis.
3. Affix the adhesive tape and replace the (M2x5) screw that secures it to the system board.
4. Affix the conductive cloth that secures the camera MIPI plate on the system board.
5. Replace the two (M2x3) screws that secure the camera MIPI plate on the system board.
6. Connect the OpExpansion module pogo connector cable to the connector on the system board.
7. Connect the rear camera flexible flat cable (FFC) to the connector on the system board.
8. Connect the power button cable to the connector on the system board.
9. Insert and slide the microSD cable and NFC cable under the grommet.
10. Place the bracket and replace the three (M2x5) screws and two (M1.6x5) screws that secure the system board to the tablet chassis.
11. Connect the power adapter cable and replace the (M2x5) screw that secures the system board to the tablet chassis.
12. Connect the following cables to their connector on the system board (L-R): microphone board, LTE main + p-sensor, mic, smartcard, fingerprint reader, microSD card, NFC, mini serial, speaker, pogo connector, right battery, and left battery from the system board.
13. As illustrated, affix the adhesive tapes to the connectors on the system board.
14. Route the GPS cable into the routing channel and connect it to the system board.
15. Slide the antenna cable into the clip and connect the antenna cables to the system board.
16. Connect the radio antenna cables and coin-cell battery cable to the system board.
17. Connect the antenna cable to the system board.

Next steps

1. Install the [WWAN](#).
2. Install the [WLAN](#).
3. Install the [solid-state drive](#).
4. Install the [system fan](#).
5. Install the [SSD heat-sink](#).
6. Install the [display assembly](#).
7. Install the [batteries](#).
8. Follow the procedure in [after working inside your tablet](#).

Rear Camera

Removing the rear camera

Prerequisites

1. Follow the procedure in [before working inside your tablet](#).
2. Remove the [batteries](#).
3. Remove the [display assembly](#).
4. Remove the [SSD heat-sink](#).
5. Remove the [system fan](#).
6. Remove the [solid-state drive](#).
7. Remove the [WLAN](#).
8. Remove the [WWAN](#).
9. Remove the [microphone](#).
10. Remove the [front camera](#).
11. Remove the [coin-cell battery](#).
12. Remove the [system board](#).

About this task

The figure indicates the location of the rear camera and provides a visual representation of the removal procedure.



3x
M2x5

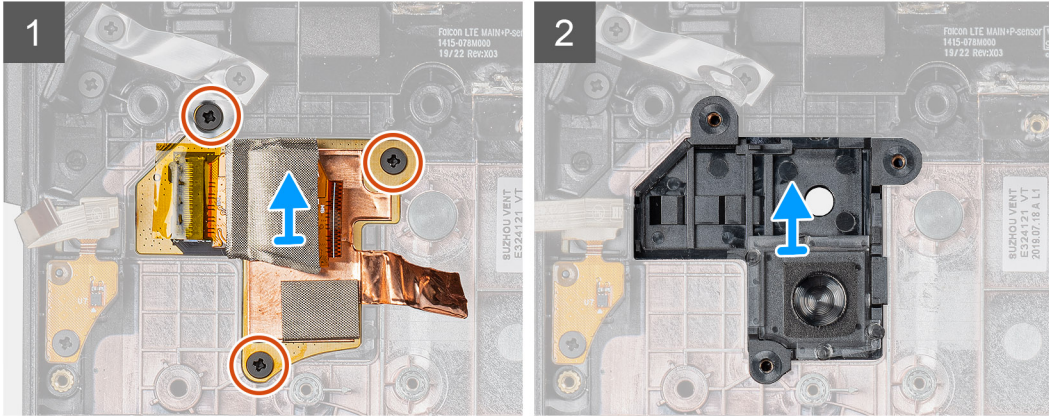
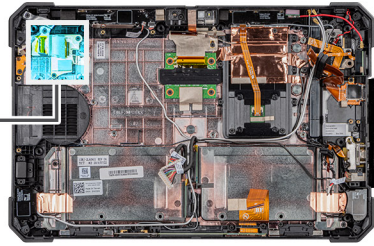

Steps

1. Peel the copper adhesive tape and remove the three (M2x5) screws that secure the rear camera circuit board on the tablet chassis.
2. Remove the back camera board cable from the chassis.

Installing the rear camera

Prerequisites

If you are replacing a component, remove the existing component before performing the installation procedure.

About this task

The figure indicates the location of the rear camera and provides a visual representation of the installation procedure.



3x
M2x5

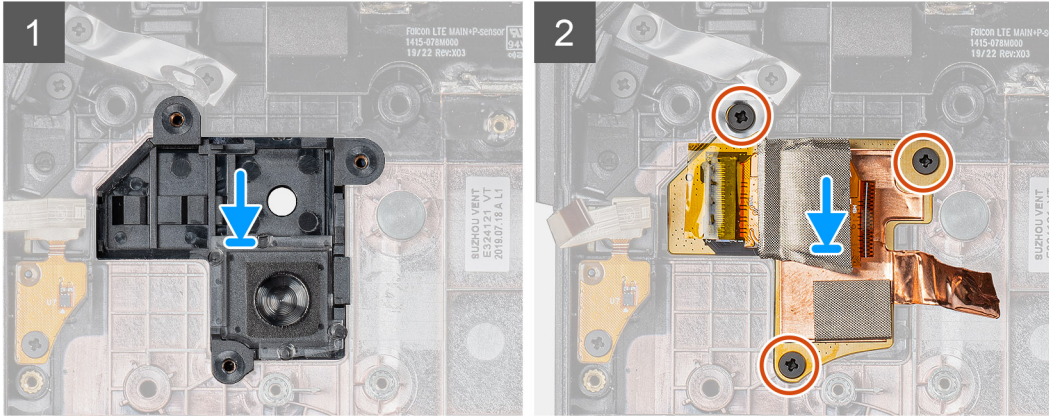
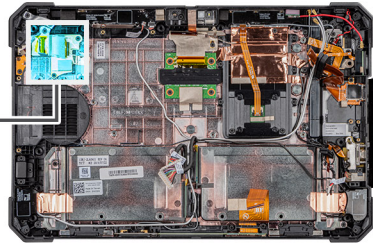

Steps

1. Align the screw holes on the rear camera circuit board with the screw holes on the tablet chassis.
2. Replace copper adhesive tape and the three (M2x5) screws to secure the rear camera circuit board to the chassis.

Next steps

1. Install the [system board](#).
2. Install the [coin-cell battery](#).
3. Install the [front camera](#).
4. Install the [microphone](#).
5. Install the [WWAN](#).
6. Install the [WLAN](#).
7. Install the [solid-state drive](#).
8. Install the [system fan](#).
9. Install the [SSD heat-sink](#).
10. Install the [display assembly](#).
11. Install the [batteries](#).
12. Follow the procedure in [after working inside your tablet](#).

Micro serial port and power connector port

Removing micro serial port and power connector port

Prerequisites

1. Follow the procedure in [before working inside your tablet](#).
2. Remove the [batteries](#).
3. Remove the [display assembly](#).

About this task

The figure indicates the location of the micro serial port and power connector (DC-in) port and provides a visual representation of the removal procedure.

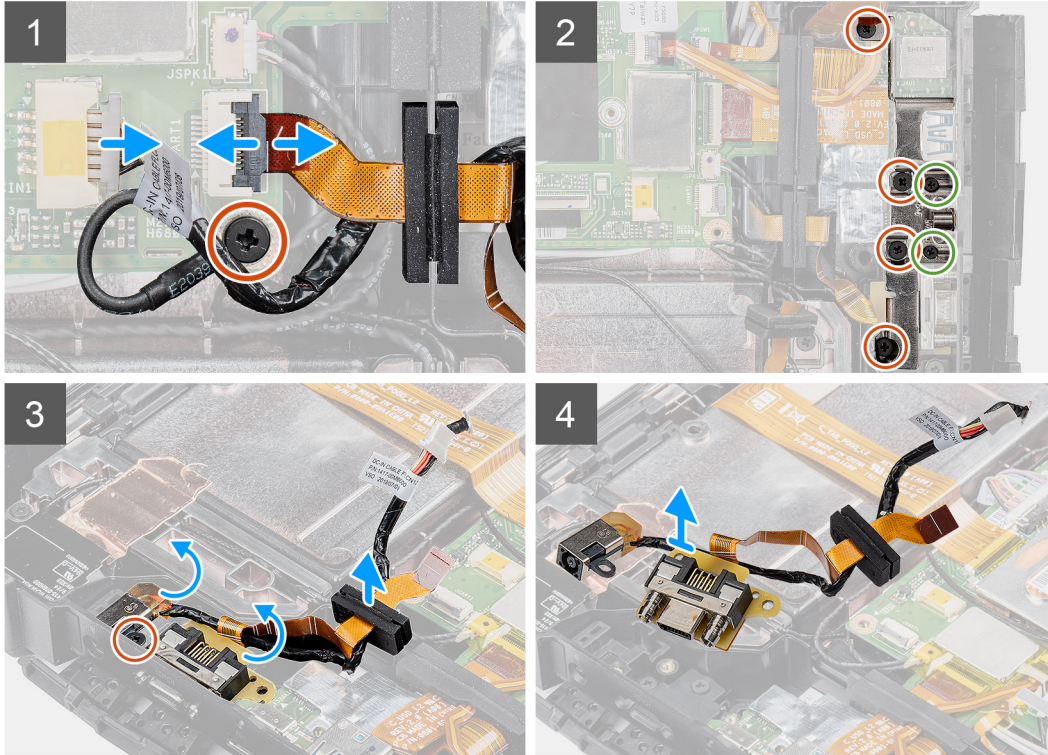
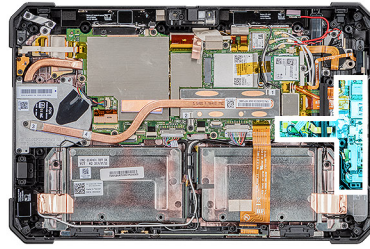

Steps

1. Disconnect the DC-in cable from the connector and remove the (M2x5) screw that secures the system board to the system chassis.
2. Lift the latch, and disconnect the micro serial port cable from the connector.
3. Remove the four (M2x5) screws and two (M1.6x5) screws that secure the metal bracket to the system chassis.
4. Lift and remove the metal bracket from system.
5. Remove the (M2x5) screw that secures the DC-in port and serial port to the system chassis.
6. Flip the cables and lift the rubber grommet to release the DC-in and serial port from the system chassis.

NOTE: Rubber grommet ensures to secure the micro serial port cable from damage.

Installing micro serial port and power connector port

Prerequisites

If you are replacing a component, remove the existing component before performing the installation procedure.

About this task

The figure indicates the location of the micro serial port and power connector (DC-in) port and provides a visual representation of the installation procedure.

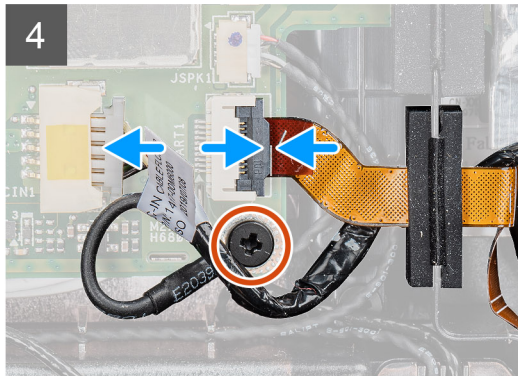
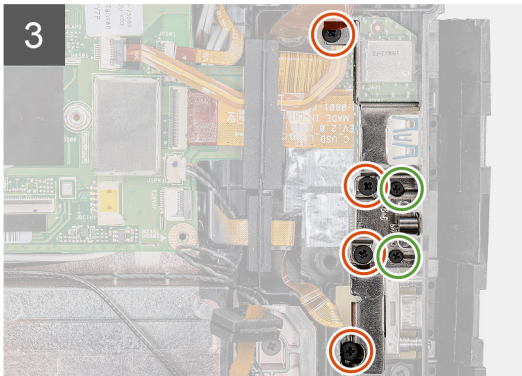
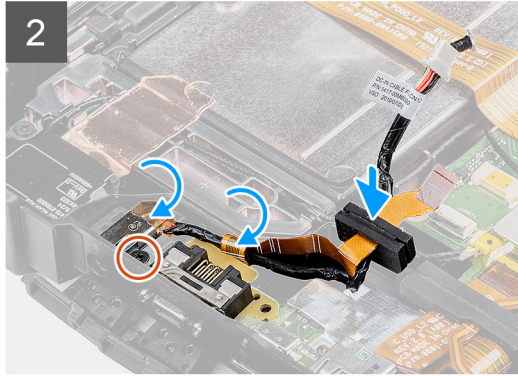
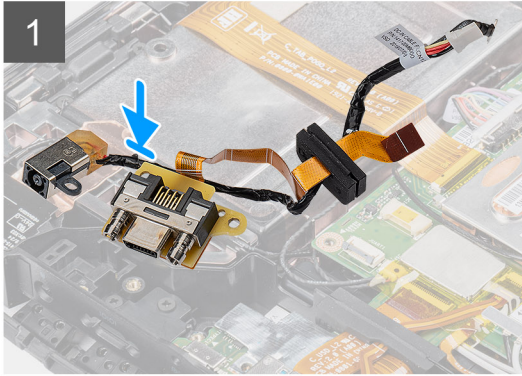
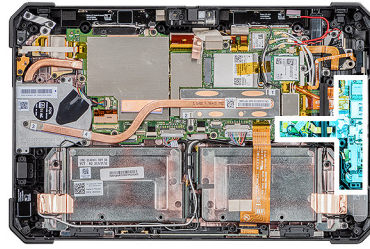

Steps

1. Insert the DC-in port and micro serial port into the slot on the chassis.
2. Replace the (M2x5) screw that secures the DC-in port and serial port to the system chassis and align the rubber grommet to slide in the channel .
3. Align the metal brackets that secure the ports on the system chassis.
4. Replace the four (M2x5) screws and two (M1.6x5) screws that secure the metal bracket to the system chassis.
5. Connect the serial port cable into the connector.
6. Close the latch to secure the serial port cable to the system board.
7. Connect the DC-in port cable to the system board and replace the (M2x5) screw that secures the system board to the system chassis.

Next steps

1. Install the [display assembly](#).
2. Install the [batteries](#).
3. Follow the procedure in [after working inside your tablet](#).

Docking Board

Removing the docking board

Prerequisites

1. Follow the procedure in [before working inside your tablet](#).
2. Remove the [batteries](#).
3. Remove the [display assembly](#).
4. Remove the [heat-sink](#).
5. Remove the [system fan](#).
6. Remove the [solid-state drive](#).
7. Remove the [WLAN](#).
8. Remove the [WWAN](#).
9. Remove the [microphone](#).
10. Remove the [front camera](#).
11. Remove the [coin-cell battery](#).
12. Remove the [system board](#).

About this task

The figure indicates the location of the docking board and provides a visual representation of the removal procedure.



5x
M2x5

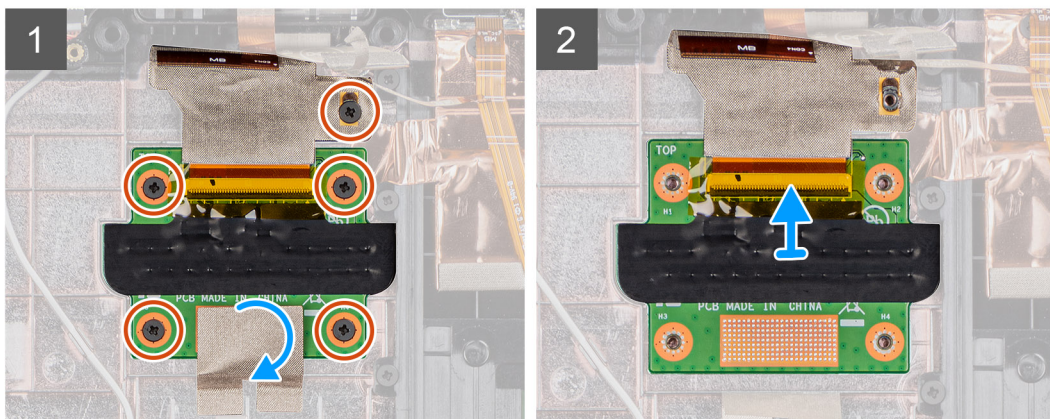
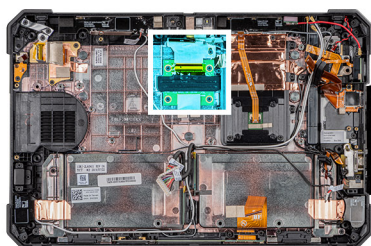

Steps

1. Remove the adhesive tape that secures the docking circuit board on the system chassis.
2. Remove the five (M2x5) screws that secure the docking circuit board on the system board chassis.
NOTE: As the docking board is positioned beneath the system board, ensure to remove the system board, to replace a faulty docking board.
3. Lift the latch, and slide to remove the docking board cable on the system board.

Installing the docking board

Prerequisites

If you are replacing a component, remove the existing component before performing the installation procedure.

About this task

The figure indicates the location of the docking board and provides a visual representation of the installation procedure.



5x
M2x5

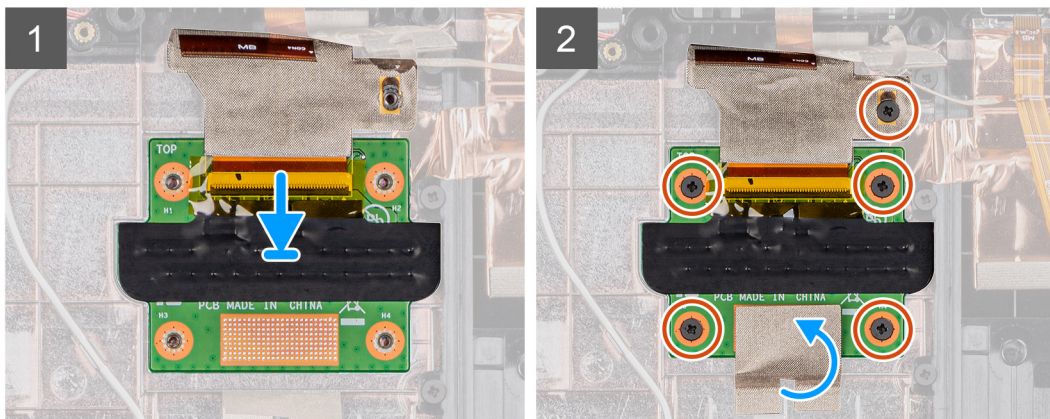
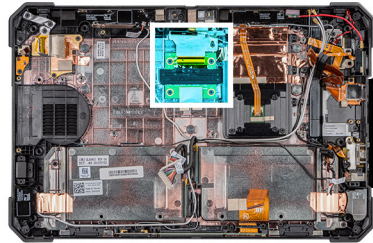

Steps

1. Connect the docking board cable to the connector.
i **NOTE:** Slide the cable through the connector clips, and release the latch.
2. Align the docking board and replace the five (M2x5) screws that secure the docking board to the system chassis.
3. Replace the adhesive tape to secure the docking board to the system chassis.

Next steps

1. Install the [system board](#).
2. Install the [coin-cell battery](#).
3. Install the [front camera](#).
4. Install the [microphone](#).
5. Install the [WWAN](#).
6. Install the [WLAN](#).
7. Install the [solid-state drive](#).
8. Install the [system fan](#).
9. Install the [heat-sink](#).
10. Install the [display assembly](#).
11. Install the [batteries](#).
12. Follow the procedure in [after working inside your tablet](#).

Smart card reader and wireless passthrough daughterboard

Removing the smart card reader and wireless passthrough daughterboard

Prerequisites

1. Follow the procedure in [before working inside your tablet](#).
2. Remove the [batteries](#).
3. Remove the [display assembly](#).
4. Remove the [heat-sink](#).
5. Remove the [system fan](#).
6. Remove the [solid-state drive](#).
7. Remove the [WLAN](#).
8. Remove the [WWAN](#).
9. Remove the [microphone](#).
10. Remove the [front camera](#).
11. Remove the [coin-cell battery](#).
12. Remove the [system board](#).
13. Remove the [docking board](#).

About this task

The figure indicates the location of the smart card reader and wireless passthrough daughterboard and provides a visual representation of the removal procedure.



10x
M2x5

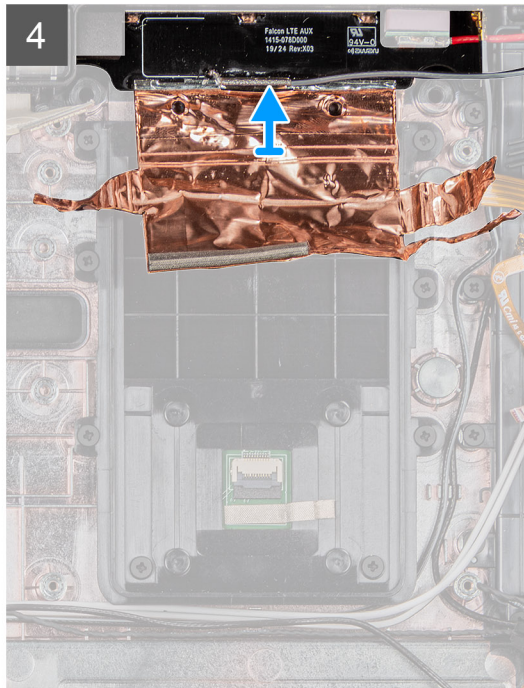
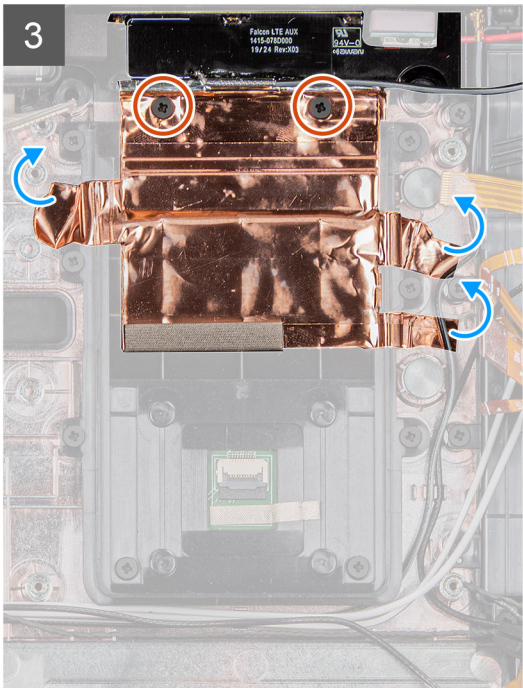
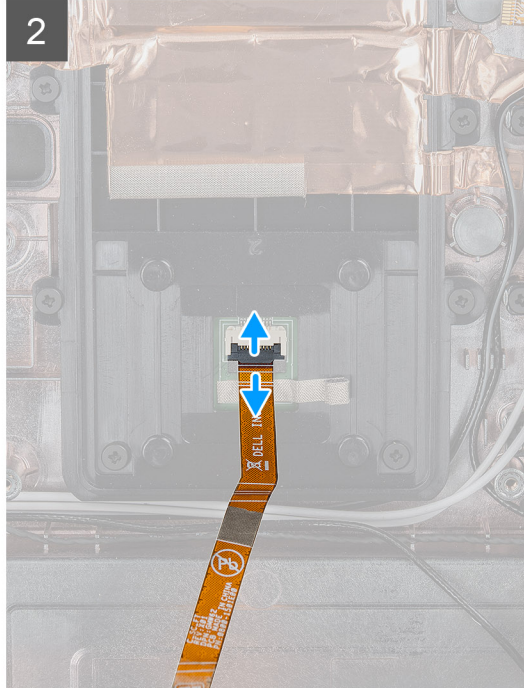
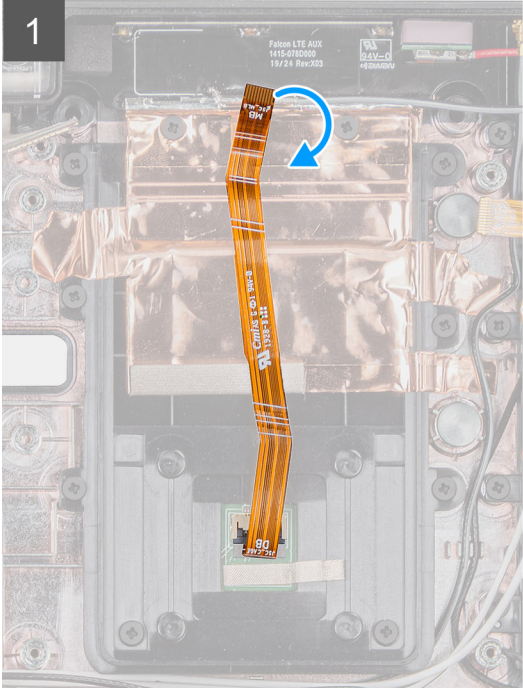
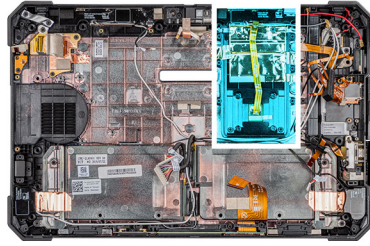

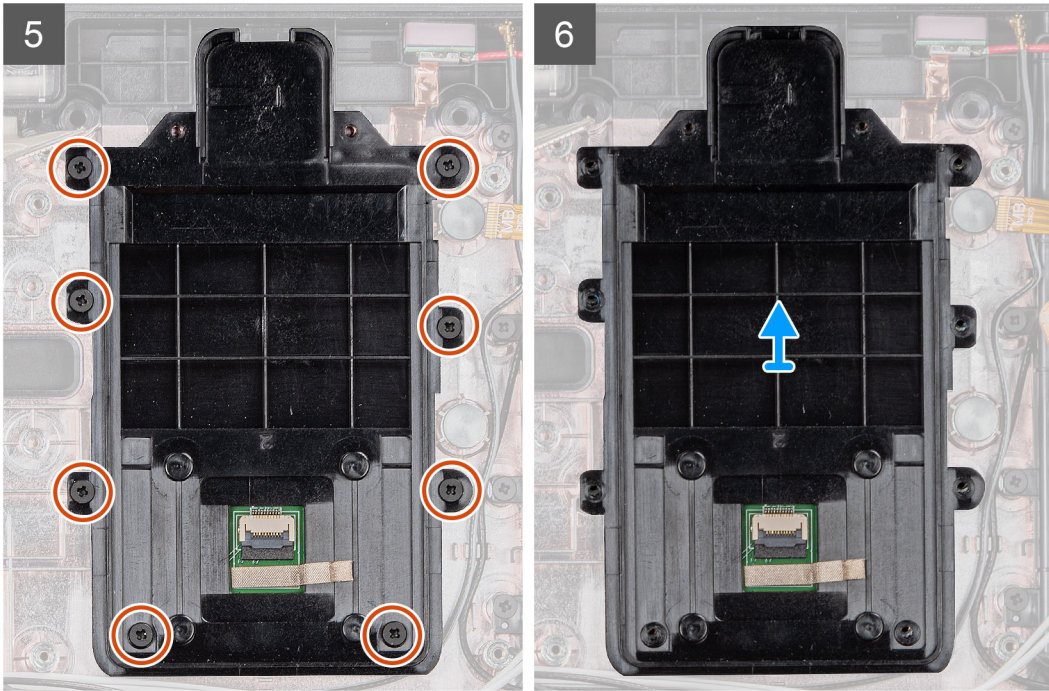

Steps

1. Flip and disconnect the smart card reader cable from the connector.
2. Remove the two (M2x5) screws that secure the wireless passthrough daughterboard to the system chassis.
3. Remove the copper adhesive shield, and lift the wireless passthrough daughterboard away from the system.
4. Remove the eight (M2x5) screws that secure the smart card reader to the system chassis.

Installing the smart card reader and wireless passthrough daughterboard

Prerequisites

If you are replacing a component, remove the existing component before performing the installation procedure.

About this task

The figure indicates the location of the smart card reader and wireless passthrough daughterboard and provides a visual representation of the installation procedure.



10x
M2x5

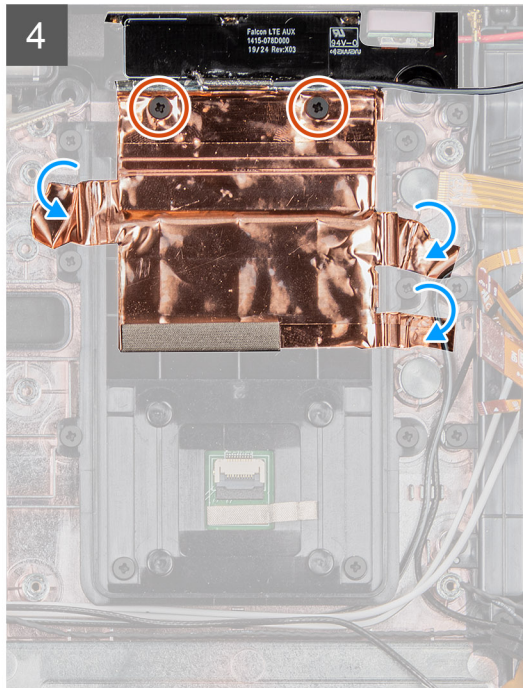
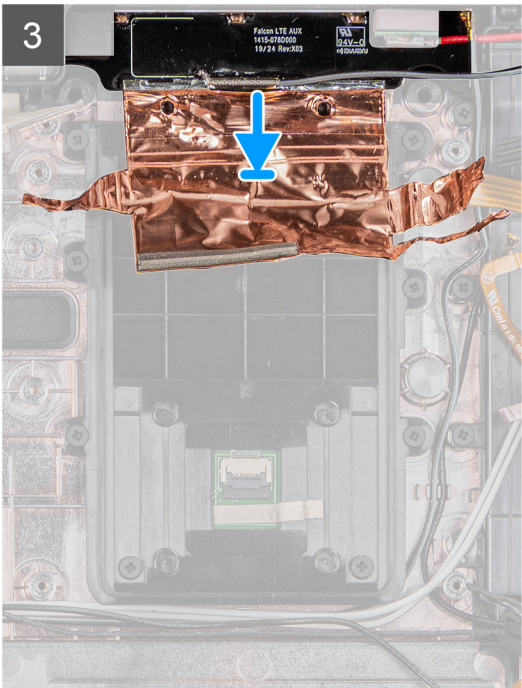
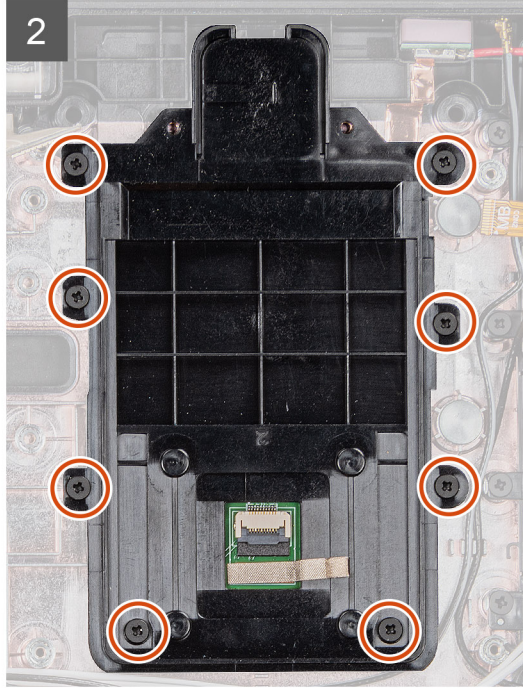
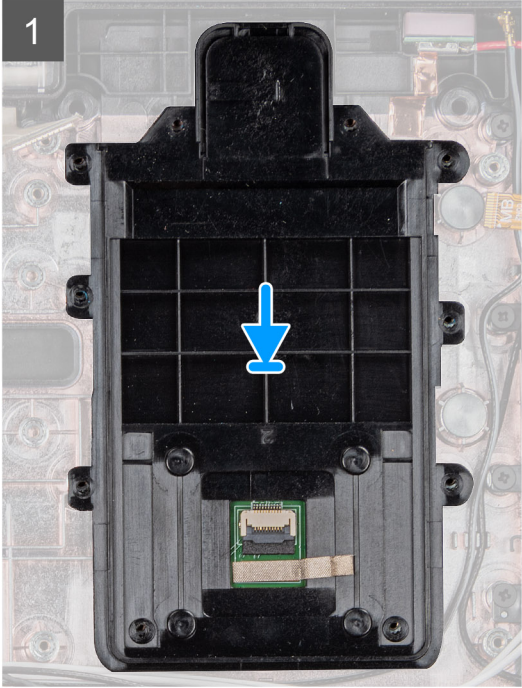
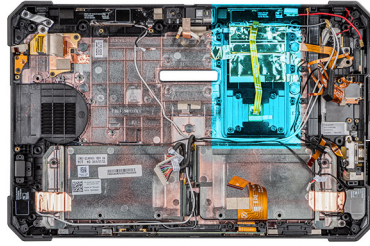

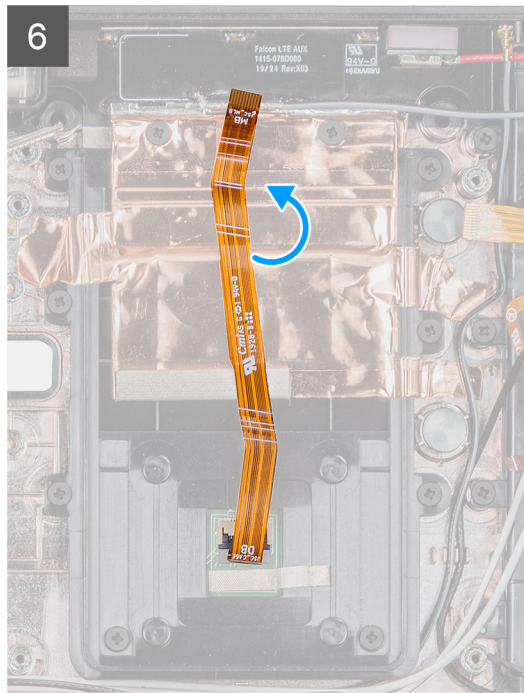
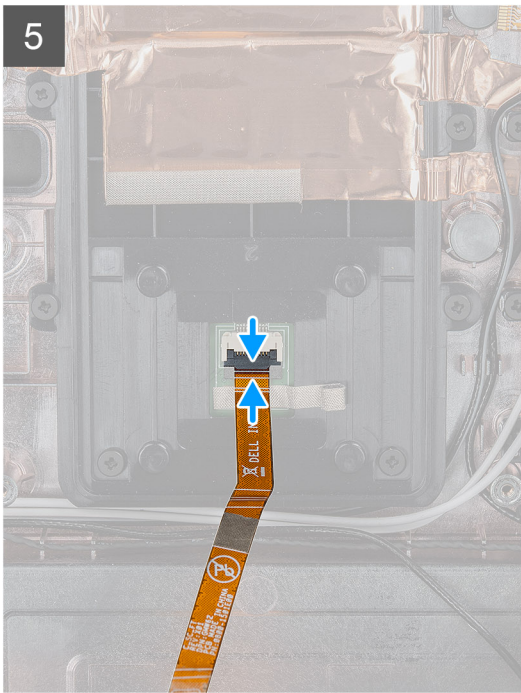

Steps

1. Align the smart card reader, and replace the eight (M2x5) screws that secure smart card reader to the system chassis.
2. Align and replace the wireless passthrough daughterboard on the system chassis.
3. Replace the copper adhesive shield to secure the wireless passthrough daughterboard to the smart card reader holder.
4. Replace the two (M2x5) screws that secure the wireless passthrough daughterboard to the system chassis.
5. Connect the smart card reader cable to the connector.
6. Flip the smart card reader cable.

Next steps

1. Install the [docking board](#).
2. Install the [system board](#).
3. Install the [coin-cell battery](#).
4. Install the [front camera](#).
5. Install the [microphone](#).
6. Install the [WWAN](#).
7. Install the [WLAN](#).
8. Install the [solid-state drive](#).
9. Install the [system fan](#).
10. Install the [heat-sink](#).
11. Install the [display assembly](#).
12. Install the [batteries](#).
13. Follow the procedure in [after working inside your tablet](#).

Software

This chapter details the supported operating systems along with instructions on how to install the drivers.

Topics:

- [Drivers and downloads](#)

Drivers and downloads

When troubleshooting, downloading or installing drivers it is recommended that you read the Dell Knowledge Based article, Drivers and Downloads FAQ [000123347](#).

System setup

CAUTION: Unless you are an expert computer user, do not change the settings in the BIOS Setup program. Certain changes can make your computer work incorrectly.

NOTE: Before you change BIOS Setup program, it is recommended that you write down the BIOS Setup program screen information for future reference.

Use the BIOS Setup program for the following purposes:

- Get information about the hardware installed in your computer, such as the amount of RAM and the size of the hard drive.
- Change the system configuration information.
- Set or change a user-selectable option, such as the user password, type of hard drive installed, and enabling or disabling base devices.

Topics:

- [Boot menu](#)
- [Navigation keys](#)
- [Boot Sequence](#)
- [System setup options](#)
- [Updating the BIOS](#)
- [System and setup password](#)

Boot menu

Press and hold the Volume down key to access the BIOS. Press and hold the Volume up key to access the one time boot menu with a list of the valid boot devices for the system. Diagnostics and BIOS Setup options are also in this menu. The devices that are listed on the boot menu depend on the bootable devices in the system. This menu is useful when you are attempting to boot to a particular device or to bring up the diagnostics for the system. Using the boot menu does not make any changes to the boot order stored in the BIOS.

The options are:

- **UEFI Boot:**
 - Windows Boot Manager
- **Other Options:**
 - BIOS Setup
 - Device Configuration
 - BIOS Flash Update
 - Diagnostics
 - SupportAssist OS Recovery
 - Exit Boot Menu and Continue

Navigation keys

NOTE: For most of the System Setup options, changes that you make are recorded but do not take effect until you restart the system.

Keys

Up arrow

Down arrow

Navigation

Moves to the previous field.

Moves to the next field.

Keys	Navigation
Enter	Selects a value in the selected field (if applicable) or follow the link in the field.
Spacebar	Expands or collapses a drop-down list, if applicable.
Tab	Moves to the next focus area.
Esc	Moves to the previous page until you view the main screen. Pressing Esc in the main screen displays a message that prompts you to save any unsaved changes and restarts the system.

Boot Sequence

Boot sequence enables you to bypass the System Setup–defined boot device order and boot directly to a specific device (for example: optical drive or hard drive). During the Power-on Self-Test (POST), when the Dell logo appears, you can:

- Access System Setup by pressing F2 key
- Bring up the one-time boot menu by pressing F12 key.

The one-time boot menu displays the devices that you can boot from including the diagnostic option. The boot menu options are:

- Removable Drive (if available)
- STXXXX Drive
 - **NOTE:** XXXX denotes the SATA drive number.
- Optical Drive (if available)
- SATA Hard Drive (if available)
- Diagnostics
 - **NOTE:** Choosing **Diagnostics**, displays the **SupportAssist** screen.

The boot sequence screen also displays the option to access the System Setup screen.

System setup options

NOTE: Depending on the tablet and its installed devices, the items listed in this section may or may not appear.

General options

Table 4. General

Option	Description
System Information	Displays the following information: <ul style="list-style-type: none"> • System Information: Displays BIOS Version, Service Tag, Asset Tag, Ownership Tag, Manufacture Date, Ownership Date, and the Express Service Code. • Memory Information: Displays Memory Installed, Memory Available, Memory Speed, Memory Channel Mode, Memory Technology, DIMM A size, and DIMM B size • Processor Information: Displays Processor Type, Core Count, Processor ID, Current Clock Speed, Minimum Clock Speed, Maximum Clock Speed, Processor L2 Cache, Processor L3 Cache, HT Capable, and 64-Bit Technology. • Device Information: Displays M.2 SATA-0, M.2 SATA-1, M.2 PCIe SSD-0, M.2 PCIe SSD-1, Passthrough MAC Address, Video Controller, Video BIOS Version, Video Memory, Panel type, Native Resolution, Audio Controller, Wi-Fi Device, Cellular Device, and Bluetooth Device.
Battery Information	Displays the battery status health and whether the AC adapter is installed.
Boot Sequence	Allows you to specify the order in which the computer attempts to find an operating system from the devices specified in this list.

Table 4. General (continued)

Option	Description
Advanced Boot Options	Allows you to select the UEFI Network Stack option, when in UEFI boot mode. By default, no option is selected.
UEFI Boot Path Security	This option controls whether or not the system will prompt the user to enter the Admin password when booting a UEFI boot path from the F12 Boot Menu. <ul style="list-style-type: none">• Always, Except Internal HDD—Default• Always, Except Internal HDD&PXE• Always• Never
Date/Time	Allows you to set the date and time settings. Changes to the system date and time take effect immediately.

System information

Table 5. System Configuration

Option	Description
SATA Operation	Allows you to configure the operating mode of the integrated hard drive controller. <ul style="list-style-type: none">• Disabled = The SATA controllers are hidden• AHCI = SATA is configured for AHCI mode• RAID ON = SATA is configured to support RAID mode (selected by default)
Smart Reporting	This field controls whether hard drive errors for integrated drives are reported during system startup. The Enable Smart Reporting option is disabled by default.
USB Configuration	Allows you to enable or disable the integrated USB controller for: <ul style="list-style-type: none">• Enable USB Boot Support• Enable External USB Port All the options are enabled by default. <ul style="list-style-type: none">• Optimize USB (selected by default)• Optimize GPS
USB PowerShare	This option configures the USB PowerShare feature behavior. <ul style="list-style-type: none">• Enable USB PowerShare - disabled by default This feature is intended to allow users to power or charge external devices, such as phones and portable music players, using the stored system battery power through the USB PowerShare port on the notebook, while the notebook is in a sleep state.
Audio	Allows you to enable or disable the integrated audio controller. The option Enable Audio is selected by default. <ul style="list-style-type: none">• Enable Microphone• Enable Internal Speaker Both the options are selected by default.
Keyboard Illumination	This field lets you choose the operating mode of the keyboard illumination feature. The keyboard brightness level can be set from 25% to 100%. The options are: <ul style="list-style-type: none">• Disabled• Level is 25%• Level is 50%• Level is 75%• Level is 100%-enabled by default

Table 5. System Configuration (continued)

Option	Description
Tablet Buttons Illumination	<p>This controls the LED brightness for the following tablet buttons: Power, Rotation Lock, LCD Brightness Down, LCD Brightness Up, Volume Down, Volume Up, P1, P2, and P3. The options are:</p> <ul style="list-style-type: none"> ● Off ● Level is 25% ● Level is 50% ● Level is 75% ● Level is 100%-enabled by default
Keyboard Backlight Timeout on AC	<p>The Keyboard Backlight Timeout dims out with AC option. The main keyboard illumination feature is not affected. Keyboard Illumination will continue to support the various illumination levels. This field has an effect when the backlight is enabled. The options are:</p> <ul style="list-style-type: none"> ● 5 sec ● 10 sec-enabled by default ● 15 sec ● 30 sec ● 1 min ● 5 min ● 15 min ● Never
Keyboard Backlight Timeout on Battery	<p>The Keyboard Backlight Timeout dims out with the Battery option. The main keyboard illumination feature is not affected. Keyboard Illumination will continue to support the various illumination levels. This field has an effect when the backlight is enabled. The options are:</p> <ul style="list-style-type: none"> ● 5 sec ● 10 sec-enabled by default ● 15 sec ● 30 sec ● 1 min ● 5 min ● 15 min ● Never
RGB Keyboard Backlight	<p>The RGB keyboard backlight feature: There are six available colors: four preset colors (white, red, green, and blue) and two user configurable colors.</p> <ul style="list-style-type: none"> ● White: Enabled and Active ● Red: Enabled ● Green: Enabled ● Blue: Enabled ● Custom1: Disabled by default ● Custom2: Disabled by default
Touchscreen	<p>This field controls whether the touchscreen is enabled or disabled</p> <ul style="list-style-type: none"> ● Touchscreen (selected by default)
Stealth Mode Control	<p>This option configures the Dell Stealth Mode feature:</p> <p>Checking 'Enable Stealth Mode' enables this feature. Default is enabled:</p> <ul style="list-style-type: none"> ● Disable onboard LEDs ● Disable onboard LCD screen ● Disable onboard speaker* ● Disable onboard fans* ● Disable Bluetooth radio* ● Disable GPS receiver*

Table 5. System Configuration (continued)

Option	Description
	<ul style="list-style-type: none"> • Disable WLAN radio* • Disable WWAN radio* * - when present
Fingerprint Reader	<ul style="list-style-type: none"> • Enable Fingerprint Reader Device (enabled by default) Enable or disable the Fingerprint Reader Device
Miscellaneous Devices	Allows you to enable or disable the following devices: <ul style="list-style-type: none"> • Enable User-Facing Camera (enabled by default) • Enable World-Facing Camera (enabled by default) • Enable Dedicated GPS Radio (enabled by default) • Enable Secure Digital (SD) Card (enabled by default) • Secure Digital (SD) Card Boot • Secure Digital (SD) Card Read-Only Mode

Video

Option **Description**

LCD Brightness Allows you to set the display brightness depending up on the power source—On Battery and On AC. The LCD brightness is independent for battery and AC adapter. It can be set using the slider.

 **NOTE:** The video setting is visible only when a video card is installed into the system.

Security

Table 6. Security

Option	Description
Admin Password	Allows you to set, change, and delete the admin password.
System Password	Allows you to set, change, and delete the system password.
Strong Password	This option lets you enable or disable strong passwords for the system.
Password Configuration	Allows you to control the minimum and maximum number of characters allowed for a administrative password and the system password. The range of characters is between 4 and 32.
Password Bypass	This option lets you bypass the System (Boot) Password and the internal HDD password prompts during a system restart. <ul style="list-style-type: none"> • Disabled — Always prompt for the system and internal HDD password when they are set. This option is enabled by default. • Reboot Bypass — Bypass the password prompts on Restarts (warm boots).  NOTE: The system will always prompt for the system and internal HDD passwords when powered on from the off state (a cold boot). Also, the system will always prompt for passwords on any module bay HDDs that may be present.
Password Change	This option lets you determine whether changes to the System and Hard Disk passwords are permitted when an administrator password is set. Allow Non-Admin Password Changes - This option is enabled by default.
Non-Admin Setup Changes	This option lets you determine whether changes to the setup option are permitted when an administrator password is set. <ul style="list-style-type: none"> • Allow Wireless Switch Changes (disabled by default)

Table 6. Security (continued)

Option	Description
UEFI Capsule Firmware Updates	This option controls whether this system allows BIOS updates via UEFI capsule update packages. This option is selected by default. Disabling this option will block BIOS updates from services such as Microsoft Windows Update and Linux Vendor Firmware Service (LVFS)
TPM 2.0 Security	Allows you to control whether the Trusted Platform Module (TPM) is visible to the operating system. <ul style="list-style-type: none"> • TPM On (default) • Clear • PPI Bypass for Enable Commands (default) • PPI Bypass for Disable Commands • PPI Bypass for Clear Commands • Attestation Enable (default) • Key Storage Enable (default) • SHA-256 (default) Choose any one option: <ul style="list-style-type: none"> • Disabled • Enabled (default)
Absolute	This field lets you Enable, Disable or Permanently Disable the BIOS module interface of the optional Absolute Persistence Module service from Absolute Software. <ul style="list-style-type: none"> • Enabled - This option is selected by default. • Disabled • Permanently Disabled
OROM Keyboard Access	This option determines whether users are able to enter Option ROM configuration screen via hotkeys during boot. <ul style="list-style-type: none"> • Enabled (default) • Disabled • One Time Enable
Admin Setup Lockout	Allows you to prevent users from entering Setup when Admin password is set. This option is not set by default.
Master Password Lockout	Allows you to disable master password support Hard Disk passwords need to be cleared before the settings can be changed. This option is not set by default.
SMM Security Mitigation	Allows you to enable or disable additional UEFI SMM Security Mitigation protections. This option is selected by default.

Secure boot

Table 7. Secure Boot

Option	Description
Secure Boot Enable	Allows you to enable or disable Secure Boot feature <ul style="list-style-type: none"> • Secure Boot Enable Option is selected by default.
Secure Boot Mode	Allows you to modify the behavior of Secure Boot to allow evaluation or enforcement of UEFI driver signatures. <ul style="list-style-type: none"> • Deployed Mode (default) • Audit Mode
Expert key Management	Allows you to manipulate the security key databases only if the system is in Custom Mode. The Enable Custom Mode option is disabled by default. The options are: <ul style="list-style-type: none"> • PK (default)

Table 7. Secure Boot (continued)

Option	Description
	<ul style="list-style-type: none"> • KEK • db • dbx <p>If you enable the Custom Mode, the relevant options for PK, KEK, db, and dbx appear. The options are:</p> <ul style="list-style-type: none"> • Save to File- Saves the key to a user-selected file • Replace from File- Replaces the current key with a key from a user-selected file • Append from File- Adds a key to the current database from a user-selected file • Delete- Deletes the selected key • Reset All Keys- Resets to default setting • Delete All Keys- Deletes all the keys <p>NOTE: If you disable the Custom Mode, all the changes made will be erased and the keys will restore to default settings.</p>

Intel Software Guard Extensions

Table 8. Intel Software Guard Extensions

Option	Description
Intel SGX Enable	<p>This field specifies you to provide a secured environment for running code/storing sensitive information in the context of the main OS.</p> <p>Click one of the following options:</p> <ul style="list-style-type: none"> • Disabled • Enabled • Software controlled—Default
Enclave Memory Size	<p>This option sets SGX Enclave Reserve Memory Size</p> <p>Click one of the following options:</p> <ul style="list-style-type: none"> • 32 MB • 64 MB • 128 MB—Default

Performance

Table 9. Performance

Option	Description
Multi Core Support	<p>This field specifies whether the process has one or all cores enabled. The performance of some applications improves with the additional cores.</p> <ul style="list-style-type: none"> • All—Default • 1 • 2 • 3
Intel SpeedStep	<p>Allows you to enable or disable the Intel SpeedStep mode of processor.</p> <ul style="list-style-type: none"> • Enable Intel SpeedStep <p>This option is set by default.</p>

Table 9. Performance (continued)

Option	Description
C-States Control	<p>Allows you to enable or disable the additional processor sleep states.</p> <ul style="list-style-type: none"> ● C states <p>This option is set by default.</p>
Intel TurboBoost	<p>Allows you to enable or disable the Intel TurboBoost mode of the processor.</p> <ul style="list-style-type: none"> ● Enable Intel TurboBoost <p>This option is set by default.</p>
Hyper-Thread Control	<p>Allows you to enable or disable the HyperThreading in the processor.</p> <ul style="list-style-type: none"> ● Disabled ● Enabled—Default

Power management

Option	Description
--------	-------------

Lid Switch

Allows you to disable the lid switch so the screen does not shut off when lid is closed.
 Default setting: Enable Lid Switch is selected.

AC Behavior

Allows you to enable or disable the computer from turning on automatically when an AC adapter is connected.
 Default setting: Wake on AC is not selected.

Enable Intel Speed Shift Technology

- Enable Intel Speed Shift Technology

Default setting: Enabled

Auto On Time

Allows you to set the time at which the computer must turn on automatically. The options are:

- Disabled
- Every Day
- Weekdays
- Select Days

Default setting: Disabled

USB Wake Support

Allows you to enable USB devices to wake the system from Standby.

i NOTE: This feature is only functional when the AC power adapter is connected. If the AC power adapter is removed during Standby, the system setup removes power from all the USB ports to conserve battery power.

- Enable Wake on Dell USB-C Dock

Wake on LAN

Allows you to enable or disable the feature that powers on the computer from the Off state when triggered by a LAN signal.

- Disabled
- LAN Only

Default setting: Disabled

Peak Shift

This option enables you to minimize the AC power consumption during the peak power times of day. After you enable this option, your system runs only in battery even if the AC is attached.

- Enable peak shift—is disabled
- Set battery threshold (15% to 100%) - 15 % (enabled by default)

Option	Description
Advanced Battery Charge Configuration	<p>This option enables you to maximize the battery health. By enabling this option, your system uses the standard charging algorithm and other techniques, during the non work hours to improve the battery health.</p> <p>Enable Advanced Battery Charge Mode- is disabled</p>
Battery#1 Charge Configuration	<p>Allows you to select the charging mode for the battery. The options are:</p> <ul style="list-style-type: none"> • Adaptive—enabled by default • Standard—Fully charges your battery at a standard rate. • ExpressCharge—The battery charges over a shorter time using Dell's fast charging technology. • Primarily AC use • Custom <p>If Custom Charge is selected, you can also configure Custom Charge Start and Custom Charge Stop.</p> <p>NOTE: All charging mode may not be available for all the batteries. To enable this option, disable the Advanced Battery Charge Configuration option.</p>
Battery#2 Charge Configuration	<p>Allows you to select the charging mode for the battery. The options are:</p> <ul style="list-style-type: none"> • Adaptive—enabled by default • Standard—Fully charges your battery at a standard rate. • ExpressCharge—The battery charges over a shorter time using Dell's fast charging technology. • Primarily AC use • Custom <p>If Custom Charge is selected, you can also configure Custom Charge Start and Custom Charge Stop.</p> <p>NOTE: All charging mode may not be available for all the batteries. To enable this option, disable the Advanced Battery Charge Configuration option.</p>
Dock Battery Charger Mode	<p>Allows you to select the charging mode for the battery. The options are:</p> <ul style="list-style-type: none"> • Standard—enabled by default • ExpressCharge—The battery charges over a shorter time using Dell's fast charging technology.
Type-C Connector Power	<p>This allows you to set the maximum power that can be drawn from the Type-C connector. The options are:</p> <ul style="list-style-type: none"> • 7.5 Watts—enabled by default • 15 Watts <p>NOTE: Setting a higher power value for the Type-C connector may cause the system to throttle sooner, if the total system power budget is exceeded.</p>
Power Usage Mode	<p>Allows you to choose the system power usage mode. The options are:</p> <ul style="list-style-type: none"> • Power Saver • Balanced • Performance-enabled by default • High Performance

POST behavior

Option	Description
Adapter Warnings	<p>Allows you to enable or disable the system setup (BIOS) warning messages when you use certain power adapters.</p> <p>Default setting: Enable Adapter Warnings</p>
USB-C Warnings	<p>Allows you to enable the system displays warning messages for USB-C devices.</p> <p>Enable Dock Warning Messages. This option is enabled by default.</p>
Keypad (Embedded)	<p>Allows you to select one of the two methods to enable the keypad that is embedded in the internal keyboard.</p> <ul style="list-style-type: none"> • Fn Key Only—enabled by default

Option	Description
	<ul style="list-style-type: none"> By Numlock
Fn Lock Options	<p>Allows you to let hot key combinations Fn + Esc toggle the primary behavior of F1–F12, between their standard and secondary functions. If you disable this option, you cannot toggle dynamically the primary behavior of these keys. The available options are:</p> <ul style="list-style-type: none"> Fn Lock—enabled by default Lock Mode Disable/Standard—enabled by default Lock Mode Enable/Secondary
Fastboot	<p>Allows you to speed up the boot process by bypassing some of the compatibility steps. The options are:</p> <ul style="list-style-type: none"> Minimal—enabled by default Thorough Auto
Extended BIOS POST Time	<p>Allows you to create an extra preboot delay. The options are:</p> <ul style="list-style-type: none"> 0 seconds—enabled by default. 5 seconds 10 seconds
Full Screen Log	<ul style="list-style-type: none"> Enable Full Screen Logo—not enabled
Sign of Life Indication	<ul style="list-style-type: none"> Enable Tablet Button LED Sign of Life—enabled by default
Warnings and errors	<ul style="list-style-type: none"> Prompt on warnings and errors—enabled by default Continue on warnings Continue on warnings and errors
MAC Address Pass-Through	<ul style="list-style-type: none"> Passthrough MAC Address—enabled by default Disabled

Manageability

Option	Description
Intel AMT Capability	<p>Allows you to provision AMT and MEBx Hotkey function is enabled, during the system boot.</p> <ul style="list-style-type: none"> Disabled Enabled - by default Restrict MEBx Access
USB Provision	<p>When enabled Intel AMT can be provisioned using the local provisioning file via a USB storage device.</p> <ul style="list-style-type: none"> Enable USB Provision - disabled by default
MEBX Hotkey	<p>Allows you to specify whether the MEBx Hotkey function should enable, during the system boot.</p> <ul style="list-style-type: none"> Enable MEBx hotkey—enabled by default

Virtualization support

Option	Description
Virtualization	<p>This field specifies whether a virtual Machine Monitor (VMM) can utilize the conditional hardware capabilities provided by Intel Virtualization Technology.</p> <p>Enable Intel Virtualization Technology—enabled by default.</p>
VT for Direct I/O	<p>Enables or disables the Virtual Machine Monitor (VMM) from utilizing the additional hardware capabilities provided by Intel® Virtualization technology for direct I/O.</p> <p>Enable VT for Direct I/O - enabled by default.</p>

Option	Description
Trusted Execution	This option specifies whether a Measured Virtual Machine Monitor (MVMM) can utilize the additional hardware capabilities provided by Intel Trusted Execution Technology. The TPM Virtualization Technology, and the Virtualization technology for direct I/O must be enabled to use this feature. Trusted Execution - disabled by default.

Wireless

Allows you to enable or disable the internal wireless devices. All the options are enabled by default.

Table 10. Wireless

Options	Descriptions
WWAN/GPS	Allows enabling/disabling of internal WWAN/GPS device
Bluetooth	Allows enabling/disabling of internal Bluetooth device
WLAN	Allows enabling/disabling of internal WLAN device
Contactless Smartcard/NFC	Allows enabling/disabling of internal Contactless Smartcard/NFC device

Table 11. Antenna Switch

Options	Descriptions
System Antennas Only	Allows enabling/disabling of System antennas
WLAN(Ant A) and WWAN(Ant B) - enabled by default	Allows enabling/disabling of WLAN and WWAN
WLAN(Ant A) and GPS(Ant B)	Allows enabling/disabling of WLAN and GPS
GPS(Ant A) and WWAN(Ant B)	Allows enabling/disabling of GPS and WWAN
WLAN(Ant A)	Allows enabling/disabling of WLAN
WWAN(Ant B)	Allows enabling/disabling of WWAN
GPS(Ant B)	Allows enabling/disabling of GPS

Maintenance screen

Option	Description
Service Tag	Displays the Service Tag of your computer.
Asset Tag	Allows you to create a system asset tag if an asset tag is not already set. This option is not set by default.
BIOS Downgrade	This controls flashing of the system firmware to previous revisions. Option 'Allow BIOS downgrade' is enabled by default.
Data Wipe	This field allows users to erase the data securely from all internal storage devices. Option 'Wipe on Next boot' is not enabled by default. The following is list of devices affected: <ul style="list-style-type: none"> • Internal SATA HDD/SSD • Internal M.2 SATA SDD • Internal M.2 PCIe SSD • Internal eMMC
BIOS Recovery	This field allows you to recover from certain corrupted BIOS conditions from a recover file on the user primary hard drive or an external USB key. <ul style="list-style-type: none"> • BIOS Recovery from Hard Drive—enabled by default • BIOS Auto-Recovery—enabled by default

System logs

Option	Description
BIOS Events	Allows you to view and clear the System Setup (BIOS) POST events.
Thermal Events	Allows you to view and clear the System Setup (Thermal) events.
Power Events	Allows you to view and clear the System Setup (Power) events.

SupportAssist System Resolution

Table 12. SupportAssist System Resolution

Option	Description
Auto OS Recovery Threshold	<p>The Auto OS recovery threshold setup option controls the automatic boot flow for SupportAssist System Resolution Console and for Dell OS recovery tool.</p> <ul style="list-style-type: none">● OFF● 1● 2—Default● 3
SupportAssist OS Recovery	<p>The SupportAssist OS Recovery option will enable or disable the boot flow for SupportAssist OS Recovery tool in the event of certain system errors.</p> <ul style="list-style-type: none">● SupportAssist OS Recovery <p>This option is set by default.</p>

About

License Information: It contains the Copyright information.

Updating the BIOS

Updating the BIOS in Windows

About this task

 **CAUTION:** If BitLocker is not suspended before updating the BIOS, the next time you reboot the system it will not recognize the BitLocker key. You will then be prompted to enter the recovery key to progress and the system will ask for this on each reboot. If the recovery key is not known this can result in data loss or an unnecessary operating system re-install. For more information on this subject, search in the Knowledge Base Resource at www.dell.com/support.

Steps

1. Go to www.dell.com/support.
2. Click **Product support**. In the **Search support** box, enter the Service Tag of your computer, and then click **Search**.
 **NOTE:** If you do not have the Service Tag, use the SupportAssist feature to automatically identify your computer. You can also use the product ID or manually browse for your computer model.
3. Click **Drivers & Downloads**. Expand **Find drivers**.
4. Select the operating system installed on your computer.

5. In the **Category** drop-down list, select **BIOS**.
6. Select the latest version of BIOS, and click **Download** to download the BIOS file for your computer.
7. After the download is complete, browse the folder where you saved the BIOS update file.
8. Double-click the BIOS update file icon and follow the on-screen instructions.
For more information, search in the Knowledge Base Resource at www.dell.com/support.

Updating the BIOS using the USB drive in Windows

About this task

 **CAUTION:** If BitLocker is not suspended before updating the BIOS, the next time you reboot the system it will not recognize the BitLocker key. You will then be prompted to enter the recovery key to progress and the system will ask for this on each reboot. If the recovery key is not known this can result in data loss or an unnecessary operating system re-install. For more information on this subject, search in the Knowledge Base Resource at www.dell.com/support.

Steps

1. Follow the procedure from step 1 to step 6 in [Updating the BIOS in Windows](#) to download the latest BIOS setup program file.
2. Create a bootable USB drive. For more information, search in the Knowledge Base Resource at www.dell.com/support.
3. Copy the BIOS setup program file to the bootable USB drive.
4. Connect the bootable USB drive to the computer that needs the BIOS update.
5. Restart the computer and press **F12**.
6. Select the USB drive from the **One Time Boot Menu**.
7. Type the BIOS setup program filename and press **Enter**.
The **BIOS Update Utility** appears.
8. Follow the on-screen instructions to complete the BIOS update.

Updating the BIOS from the F12 One-Time boot menu

Update your computer BIOS using the BIOS update.exe file that is copied to a FAT32 USB drive and booting from the F12 One-Time boot menu.

About this task

 **CAUTION:** If BitLocker is not suspended before updating the BIOS, the next time you reboot the system it will not recognize the BitLocker key. You will then be prompted to enter the recovery key to progress and the system will ask for this on each reboot. If the recovery key is not known this can result in data loss or an unnecessary operating system re-install. For more information on this subject, search in the Knowledge Base Resource at www.dell.com/support.

BIOS Update

You can run the BIOS update file from Windows using a bootable USB drive or you can also update the BIOS from the F12 One-Time boot menu on the computer.

Most of the Dell computers built after 2012 have this capability, and you can confirm by booting your computer to the F12 One-Time Boot Menu to see if BIOS FLASH UPDATE is listed as a boot option for your computer. If the option is listed, then the BIOS supports this BIOS update option.

 **NOTE:** Only computers with BIOS Flash Update option in the F12 One-Time boot menu can use this function.

Updating from the One-Time boot menu

To update your BIOS from the F12 One-Time boot menu, you need the following:

- USB drive formatted to the FAT32 file system (key does not have to be bootable)
- BIOS executable file that you downloaded from the Dell Support website and copied to the root of the USB drive
- AC power adapter that is connected to the computer

- Functional computer battery to flash the BIOS

Perform the following steps to perform the BIOS update flash process from the F12 menu:

 **CAUTION: Do not turn off the computer during the BIOS update process. The computer may not boot if you turn off your computer.**

Steps

1. From a turn off state, insert the USB drive where you copied the flash into a USB port of the computer.
2. Turn on the computer and press F12 to access the One-Time Boot Menu, select BIOS Update using the mouse or arrow keys then press Enter.
The flash BIOS menu is displayed.
3. Click **Flash from file**.
4. Select external USB device.
5. Select the file and double-click the flash target file, and then click **Submit**.
6. Click **Update BIOS**. The computer restarts to flash the BIOS.
7. The computer will restart after the BIOS update is completed.

System and setup password

Table 13. System and setup password

Password type	Description
System password	Password that you must enter to log on to your system.
Setup password	Password that you must enter to access and make changes to the BIOS settings of your computer.

You can create a system password and a setup password to secure your computer.

 **CAUTION: The password features provide a basic level of security for the data on your computer.**

 **CAUTION: Anyone can access the data stored on your computer if it is not locked and left unattended.**

 **NOTE:** System and setup password feature is disabled.

Assigning a system setup password

Prerequisites

You can assign a new **System or Admin Password** only when the status is in **Not Set**.

About this task

To enter the system setup, press F2 immediately after a power-on or reboot.

Steps

1. In the **System BIOS** or **System Setup** screen, select **Security** and press **Enter**.
The **Security** screen is displayed.
2. Select **System/Admin Password** and create a password in the **Enter the new password** field.
Use the following guidelines to assign the system password:
 - A password can have up to 32 characters.
 - The password can contain the numbers 0 through 9.
 - Only lower case letters are valid, upper case letters are not allowed.
 - Only the following special characters are allowed: space, ("), (+), (.), (-), (.), (/), (;), ([], (\), (]), (`).
3. Type the system password that you entered earlier in the **Confirm new password** field and click **OK**.

4. Press **Esc** and a message prompts you to save the changes.
5. Press **Y** to save the changes.
The computer reboots.

Deleting or changing an existing system setup password

Prerequisites

Ensure that the **Password Status** is Unlocked (in the System Setup) before attempting to delete or change the existing System and Setup password. You cannot delete or change an existing System or Setup password, if the **Password Status** is Locked.

About this task

To enter the System Setup, press **F2** immediately after a power-on or reboot.

Steps

1. In the **System BIOS** or **System Setup** screen, select **System Security** and press **Enter**.
The **System Security** screen is displayed.
2. In the **System Security** screen, verify that **Password Status** is **Unlocked**.
3. Select **System Password**, alter or delete the existing system password and press **Enter** or **Tab**.
4. Select **Setup Password**, alter or delete the existing setup password and press **Enter** or **Tab**.

 **NOTE:** If you change the System and/or Setup password, re enter the new password when prompted. If you delete the System and Setup password, confirm the deletion when prompted.

5. Press **Esc** and a message prompts you to save the changes.
6. Press **Y** to save the changes and exit from System Setup.
The computer restarts.

Troubleshooting

Topics:

- [Handling swollen Lithium-ion batteries](#)
- [Dell SupportAssist Pre-boot System Performance Check diagnostics](#)
- [System diagnostic lights](#)
- [Recovering the operating system](#)
- [WiFi power cycle](#)

Handling swollen Lithium-ion batteries

Like most laptops, Dell laptops use lithium-ion batteries. One type of lithium-ion battery is the lithium-ion polymer battery. Lithium-ion polymer batteries have increased in popularity in recent years and have become standard in the electronics industry due to customer preferences for a slim form factor (especially with newer ultra-thin laptops) and long battery life. Inherent to lithium-ion polymer battery technology is the potential for swelling of the battery cells.

Swollen battery may impact the performance of the laptop. To prevent possible further damage to the device enclosure or internal components leading to malfunction, discontinue the use of the laptop and discharge it by disconnecting the AC adapter and letting the battery drain.

Swollen batteries should not be used and should be replaced and disposed of properly. We recommend contacting Dell product support for options to replace a swollen battery under the terms of the applicable warranty or service contract, including options for replacement by a Dell authorized service technician.

The guidelines for handling and replacing Lithium-ion batteries are as follows:

- Exercise caution when handling Lithium-ion batteries.
- Discharge the battery before removing it from the system. To discharge the battery, unplug the AC adapter from the system and operate the system only on battery power. When the system will no longer power on when the power button is pressed, the battery is fully discharged.
- Do not crush, drop, mutilate, or penetrate the battery with foreign objects.
- Do not expose the battery to high temperatures, or disassemble battery packs and cells.
- Do not apply pressure to the surface of the battery.
- Do not bend the battery.
- Do not use tools of any type to pry on or against the battery.
- If a battery gets stuck in a device as a result of swelling, do not try to free it as puncturing, bending, or crushing a battery can be dangerous.
- Do not attempt to reassemble a damaged or swollen battery into a laptop.
- Swollen batteries that are covered under warranty should be returned to Dell in an approved shipping container (provided by Dell)—this is to comply with transportation regulations. Swollen batteries that are not covered under warranty should be disposed of at an approved recycling center. Contact Dell product support at <https://www.dell.com/support> for assistance and further instructions.
- Using a non-Dell or incompatible battery may increase the risk of fire or explosion. Replace the battery only with a compatible battery purchased from Dell that is designed to work with your Dell computer. Do not use a battery from other computers with your computer. Always purchase genuine batteries from <https://www.dell.com> or otherwise directly from Dell.

Lithium-ion batteries can swell for various reasons such as age, number of charge cycles, or exposure to high heat. For more information on how to improve the performance and lifespan of the laptop battery and to minimize the possibility of occurrence of the issue, search Dell Laptop Battery in the Knowledge Base Resource at www.dell.com/support.

Dell SupportAssist Pre-boot System Performance Check diagnostics

About this task

SupportAssist diagnostics (also known as system diagnostics) performs a complete check of your hardware. The Dell SupportAssist Pre-boot System Performance Check diagnostics is embedded with the BIOS and is launched by the BIOS internally. The embedded system diagnostics provides a set of options for particular devices or device groups allowing you to:

- Run tests automatically or in an interactive mode
- Repeat tests
- Display or save test results
- Run thorough tests to introduce additional test options to provide extra information about the failed device(s)
- View status messages that inform you if tests are completed successfully
- View error messages that inform you of problems encountered during testing

 **NOTE:** Some tests for specific devices require user interaction. Always ensure that you are present at the computer terminal when the diagnostic tests are performed.

For more information, see <https://www.dell.com/support/kbdoc/000180971>.

Running the ePSA diagnostics

About this task

 **NOTE:** A keyboard must be connected to the tablet using USB port or docking port to perform the following tasks:

Steps

1. Turn on your computer.
2. As the computer boots, press the F12 key as the Dell logo appears.
3. If no keyboard attached, Press and hold the volume up key to access the one time boot menu.
4. On the boot menu screen, select the **Diagnostics** option.
5. Click the arrow at the bottom left corner.
Diagnostics front page is displayed.
6. Click the arrow in the lower-right corner to go to the page listing.
The items that are detected are listed.
7. To run a diagnostic test on a specific device, press Esc and click **Yes** to stop the diagnostic test.
8. Select the device from the left pane and click **Run Tests**.
9. If there are any issues, error codes are displayed.
Note the error code and validation number and contact Dell.

System diagnostic lights

Battery-status light

Indicates the power and battery-charge status.

Solid green — Power adapter is connected and the battery has more than 5 percent charge.

Amber — Computer is running on battery and the battery has less than 5 percent charge.

Off

- Power adapter is connected and the battery is fully charged.
- Computer is running on battery and the battery has more than 5 percent charge.
- Computer is in sleep state, hibernation, or turned off.

The power and battery-status light blinks amber along with beep codes indicating failures.

For example, the power and battery-status light blinks amber two times followed by a pause, and then blinks white three times followed by a pause. This 2,3 pattern continues until the computer is turned off indicating no memory or RAM is detected.

The following table shows different power and battery-status light patterns and associated problems.

Table 14. LED codes

Diagnostic light codes	Problem description
2,1	Processor failure
2,2	System board: BIOS or ROM (Read-Only Memory) failure
2,3	No memory or RAM (Random-Access Memory) detected
2,4	Memory or RAM (Random-Access Memory) failure
2,5	Invalid memory installed
2,6	System-board or chipset error
2,7	Display failure
2,8	LCD power rail failure. Replace system board
3,1	Coin-cell battery failure
3,2	PCI, video card/chip failure
3,3	Recovery image not found
3,4	Recovery image found but invalid
3,5	Power-rail failure
3,6	System BIOS Flash incomplete
3,7	Management Engine (ME) error

Camera status light: Indicates whether the camera is in use.

- Solid white — Camera is in use.
- Off — Camera is not in use.

Caps Lock status light: Indicates whether Caps Lock is enabled or disabled.

- Solid white — Caps Lock enabled.
- Off — Caps Lock disabled.

Recovering the operating system

When your computer is unable to boot to the operating system even after repeated attempts, it automatically starts Dell SupportAssist OS Recovery.

Dell SupportAssist OS Recovery is a standalone tool that is preinstalled in all Dell computers installed with Windows operating system. It consists of tools to diagnose and troubleshoot issues that may occur before your computer boots to the operating system. It enables you to diagnose hardware issues, repair your computer, back up your files, or restore your computer to its factory state.

You can also download it from the Dell Support website to troubleshoot and fix your computer when it fails to boot into their primary operating system due to software or hardware failures.

For more information about the Dell SupportAssist OS Recovery, see *Dell SupportAssist OS Recovery User's Guide* at www.dell.com/serviceabilitytools. Click **SupportAssist** and then, click **SupportAssist OS Recovery**.

WiFi power cycle

About this task

If your computer is unable to access the internet due to WiFi connectivity issues a WiFi power cycle procedure may be performed. The following procedure provides the instructions on how to conduct a WiFi power cycle:

 **NOTE:** Some ISPs (Internet Service Providers) provide a modem/router combo device.

Steps



1. Turn off your computer.
2. Turn off the modem.
3. Turn off the wireless router.
4. Wait for 30 seconds.
5. Turn on the wireless router.
6. Turn on the modem.
7. Turn on your computer.

Getting help and contacting Dell

Self-help resources

You can get information and help on Dell products and services using these self-help resources:

Table 15. Self-help resources

Self-help resources	Resource location
Information about Dell products and services	www.dell.com
My Dell app	
Tips	
Contact Support	In Windows search, type <code>Contact Support</code> , and press Enter.
Online help for operating system	www.dell.com/support/windows
Access top solutions, diagnostics, drivers and downloads, and learn more about your computer through videos, manuals and documents.	Your Dell computer is uniquely identified by a Service Tag or Express Service Code. To view relevant support resources for your Dell computer, enter the Service Tag or Express Service Code at www.dell.com/support . For more information on how to find the Service Tag for your computer, see Locate the Service Tag on your computer .
Dell knowledge base articles for a variety of computer concerns	<ol style="list-style-type: none"> 1. Go to www.dell.com/support. 2. On the menu bar at the top of the Support page, select Support > Knowledge Base. 3. In the Search field on the Knowledge Base page, type the keyword, topic, or model number, and then click or tap the search icon to view the related articles.

Contacting Dell

To contact Dell for sales, technical support, or customer service issues, see www.dell.com/contactdell.

 **NOTE:** Availability varies by country/region and product, and some services may not be available in your country/region.

 **NOTE:** If you do not have an active Internet connection, you can find contact information about your purchase invoice, packing slip, bill, or Dell product catalog.