

Dell EMC XC6420 Series Hyper-Converged Appliance

Installation and Service Manual

Notes, cautions, and warnings

 **NOTE:** A NOTE indicates important information that helps you make better use of your product.

 **CAUTION:** A CAUTION indicates either potential damage to hardware or loss of data and tells you how to avoid the problem.

 **WARNING:** A WARNING indicates a potential for property damage, personal injury, or death.

© 2018 Dell Inc. or its subsidiaries. All rights reserved. Dell, EMC, and other trademarks are trademarks of Dell Inc. or its subsidiaries. Other trademarks may be trademarks of their respective owners.

Contents

| | |
|---|-----------|
| 1 XC6420 Series overview | 7 |
| Back view of the XC6420 Series sled | 7 |
| Network ports indicator codes | 8 |
| Sled to hard drive mapping | 10 |
| Locating the Service Tag of your system | 10 |
| 2 Documentation resources | 12 |
| 3 Technical specifications | 13 |
| Dimensions of the XC6420 Series sled | 13 |
| Chassis weight | 14 |
| Processor specifications | 14 |
| System battery | 14 |
| Expansion bus specifications | 14 |
| Memory specifications | 14 |
| Hard drives and storage specifications | 15 |
| Video specifications | 15 |
| Environmental specifications | 16 |
| Temperature specifications | 16 |
| Relative humidity specifications | 16 |
| Maximum vibration specifications | 16 |
| Maximum shock specifications | 17 |
| Maximum altitude specifications | 17 |
| Operating temperature de-rating specifications | 17 |
| Particulate and gaseous contamination specifications | 18 |
| Standard operating temperature specifications | 18 |
| Expanded operating temperature specifications | 22 |
| 4 Initial system setup and configuration | 24 |
| Setting up your system | 24 |
| iDRAC configuration | 24 |
| Options to set up iDRAC IP address | 24 |
| Log in to iDRAC | 25 |
| Methods to download firmware and drivers | 25 |
| Downloading drivers and firmware | 25 |
| 5 Pre-operating system management applications | 27 |
| Options to manage the pre-operating system applications | 27 |
| System Setup | 27 |
| Viewing System Setup | 27 |
| System Setup details | 28 |
| System BIOS | 28 |

| | |
|----------------------------------|----|
| iDRAC Settings utility..... | 47 |
| Device Settings..... | 47 |
| Dell Lifecycle Controller..... | 47 |
| Embedded systems management..... | 47 |
| Boot Manager..... | 47 |
| Viewing Boot Manager..... | 47 |
| Boot Manager main menu..... | 48 |
| One-shot BIOS boot menu..... | 48 |
| System Utilities..... | 48 |
| PXE boot..... | 48 |

6 Installing and removing system components..... 49

| | |
|--|----|
| Safety instructions..... | 49 |
| Before working inside your system..... | 49 |
| After working inside your system..... | 49 |
| Recommended tools..... | 49 |
| Inside the sled..... | 50 |
| XC6420 Series sled..... | 50 |
| Removing a sled | 50 |
| Installing a sled | 52 |
| Air shroud..... | 54 |
| Removing the air shroud..... | 54 |
| Installing the air shroud | 55 |
| System memory..... | 56 |
| General memory module installation guidelines..... | 57 |
| Mode-specific guidelines..... | 58 |
| Removing a memory module..... | 58 |
| Installing a memory module..... | 59 |
| Support bracket..... | 60 |
| Removing the support bracket..... | 60 |
| Installing the support bracket..... | 60 |
| Expansion cards..... | 61 |
| PCIe slot priority | 61 |
| Removing the expansion card riser assembly..... | 62 |
| Installing the expansion card riser assembly..... | 63 |
| Removing an expansion card..... | 64 |
| Installing an expansion card..... | 66 |
| Removing the riser card..... | 68 |
| Installing the riser card..... | 69 |
| M.2 SATA drive..... | 70 |
| Removing the M.2 SATA x16 riser..... | 70 |
| Installing the M.2 SATA x16 riser..... | 71 |
| Removing the M.2 SATA card..... | 72 |
| Installing the M.2 SATA card..... | 73 |
| Mezzanine and OCP cards..... | 74 |
| Removing a mezzanine card..... | 74 |

| | |
|---|-----------|
| Installing a mezzanine card..... | 75 |
| Removing the mezzanine card bridge board | 77 |
| Installing the mezzanine card bridge board..... | 77 |
| Removing the OCP card..... | 78 |
| Installing the OCP card..... | 79 |
| System battery..... | 80 |
| Replacing system battery..... | 80 |
| Installing the system battery..... | 81 |
| Trusted Platform Module..... | 82 |
| Replacing the Trusted Platform Module..... | 82 |
| Initializing the TPM 1.2 for TXT users..... | 83 |
| Initializing the TPM 2.0 for TXT users..... | 84 |
| 7 Using system diagnostics..... | 85 |
| Dell Embedded System Diagnostics..... | 85 |
| Running the Embedded System Diagnostics from Boot Manager..... | 85 |
| Running the Embedded System Diagnostics from the Dell Lifecycle Controller..... | 85 |
| System diagnostic controls..... | 86 |
| 8 Jumpers and connectors | 87 |
| System board jumper settings..... | 87 |
| System board connectors..... | 88 |
| Disabling forgotten password..... | 89 |
| 9 Getting help..... | 90 |
| Contacting Dell..... | 90 |
| Documentation feedback..... | 90 |
| Accessing system information by using QRL..... | 90 |
| Quick Resource Locator for XC6420 systems..... | 91 |
| Receiving automated support with SupportAssist | 91 |
| A BOSS card..... | 92 |
| Introduction to BOSS card..... | 92 |
| Supported operating systems..... | 92 |
| Supported XC Series systems | 92 |
| BOSS card features..... | 93 |
| Foreign Import..... | 93 |
| SMART Info..... | 93 |
| Auto-Rebuild..... | 93 |
| BOSS card replacement by using Foreign Import option..... | 93 |
| Driver installation..... | 97 |
| BOSS troubleshooting..... | 97 |
| Physical disks not visible to operating system..... | 97 |
| Virtual disk not visible to operating system..... | 98 |
| Drive failure..... | 98 |
| Fault in controller..... | 98 |
| BOSS card is not detected..... | 98 |

| | |
|--|----|
| Unable to boot to M.2 drive installed in slot 1..... | 99 |
| CLI reports unsupported features | 99 |

XC6420 Series overview

The XC6420 Series sled supports up to two Intel Xeon Scalable E5-2600 product family processors with 28 cores per processor. The sled also supports 16 memory modules, dedicated mezzanine, PCIe and Open Compute Project (OCP) adapters for expansion and connectivity.

NOTE: The Intel Xeon Scalable processor with fabric connector is also known as Native Omnipath.

Topics:

- Back view of the XC6420 Series sled
- Network ports indicator codes
- Sled to hard drive mapping
- Locating the Service Tag of your system

Back view of the XC6420 Series sled

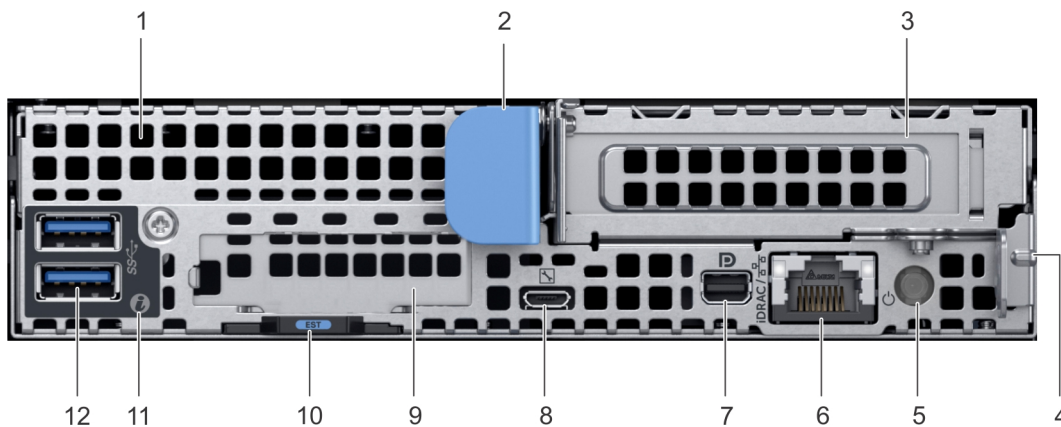







Figure 1. Back view of the XC6420 Series sled

Table 1. Back panel features

| Item | Indicator, button, or connector | Icon | Description |
|------|---------------------------------|------|--|
| 1 | mezzanine card slot | N/A | Enables you to connect mezzanine expansion cards. For more information, see Technical specifications . |
| 2 | sled release handle | N/A | Enables you to remove the sled from the enclosure. |
| 3 | Low Profile PCIe card slot | N/A | Enables you to connect PCI Express expansion cards. For more information, see Technical specifications . |
| 4 | sled release lock | N/A | Enables you to remove the sled from the enclosure. |
| 5 | rear power button | N/A | Enables you to power on the sled while accessing it from the rear. |

| Item | Indicator, button, or connector | Icon | Description |
|------|---------------------------------|---|---|
| 6 | iDRAC or NIC port | iDRAC /  | Enables you to remotely access iDRAC. For more information, see the iDRAC User's Guide at Dell.com/poweredgemanuals . |
| 7 | mini display port |  | Enables you to connect a display device to the system. For more information, see Technical specifications . |
| 8 | iDRAC Direct micro USB port |  | Enables you to connect a portable device to the sled. |
| 9 | OCP card slot | N/A | Enables you to connect Open Compute Project (OCP) expansion cards. For more information, see Technical specifications . |
| 10 | EST pull out tab | N/A | This tab has the unique Express Service Code, Service Tag, and MAC address labels. |
| 11 | system id indicator |  | The System Identification (ID) LED is available on the back of the system. Press the system ID button on the front of the enclosure to identify a system in a rack. |
| 12 | USB 3.0 port (2) |  | The USB ports are 9-pin and 3.0-compliant. These ports enable you to connect USB devices to the system. |

Network ports indicator codes



Figure 2. LAN indicators on the QSFPP carrier card

- 1 Link indicator

Table 3. Ethernet port indicator codes

| Convention | Status | Condition |
|------------|--------------------------------------|--|
| A | Link and activity indicators are off | The NIC is not connected to the network. |
| B | Link indicator is green | The NIC is connected to a valid network at its maximum port speed. |
| C | Link indicator is amber | The NIC is connected to a valid network at less than its maximum port speed. |
| D | Activity indicator is flashing green | Network data is being sent or received. |

Sled to hard drive mapping

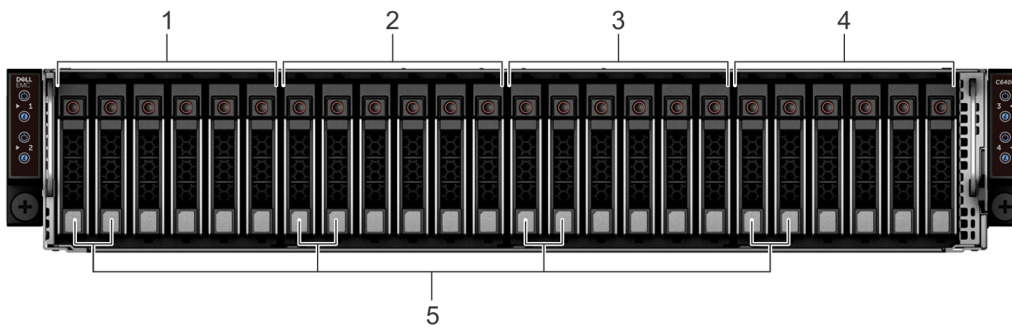

Figure 5. Sled to drive mapping for the enclosure with 24 x 2.5 inch drives

- | | | | |
|---|-------------------------------------|---|-------------------------------|
| 1 | drives 0–5 mapped to sled 1 | 2 | drives 6–11 mapped to sled 2 |
| 3 | drives 12–17 mapped to sled 3 | 4 | drives 18–23 mapped to sled 4 |
| 5 | (optional) NVMe hard drive location | | |

NOTE: The warranty of the drives are linked to the Service Tag of the corresponding sled.

Locating the Service Tag of your system

Your system is identified by a unique Express Service Code and Service Tag number. The Express Service Code and Service Tag are found on the back of the sled by pulling out the EST tag. This information is used by Dell EMC to route support calls to the appropriate personnel.

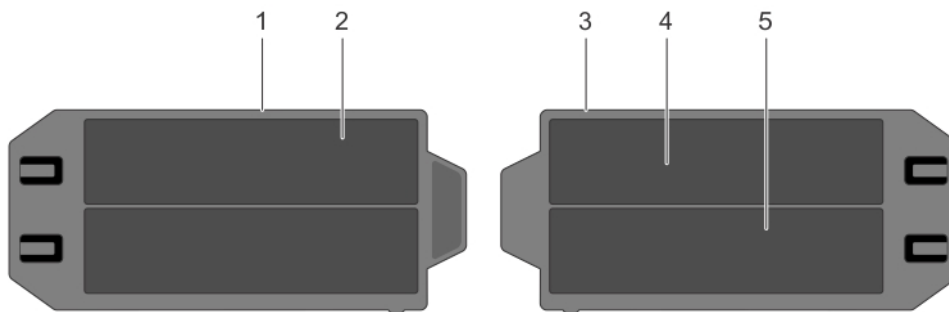

Figure 6. Locating the Service Tag of your system

- | | | | |
|---|-------------------------------|---|---------------------------------------|
| 1 | information tag (top view) | 2 | Express Service Tag label |
| 3 | information tag (bottom view) | 4 | network MAC address information label |

5 iDRAC MAC address information label

Documentation resources

Dell EMC documentation is either included with your shipment or available at the Dell website at Dell.com/XCseriesmanuals.

Dell EMC documentation for Dell EMC iDRAC is available at Dell.com/idracmanuals.

To access the Dell EMC documentation:

- 1 On the Dell EMC Support page, scroll down to **General Support**, and then click **Servers, Storage & Networking**.
- 2 Click **Engineered Solutions** and select the documentation you require.

Table 4. Reference documentation for Dell EMC XC6420 Series Hyper-converged Appliance

| To learn about... | See... |
|--|---|
| Set up instructions of your Dell EMC XC6420 Series, including the technical specifications | <i>Getting Started Guide</i> |
| Hardware details of your Dell EMC XC6420 Series | <i>Installation and Service Manual</i> |
| How to install your Dell EMC XC6420 Series in a rack | <i>Rail Installation Guide</i> |
| How to deploy your XC6420 Series and set up this solution | <i>Solutions Guide</i> |
| Deploying Azure Log Analytics Solution | <i>Dell EMC XC Series Azure Log Analytics Solution Deployment Guide</i> |
| ESXi Best Practices Guide | <i>Dell EMC Best Practices for Running VMware ESXi 6.5 or Later Clusters on XC Series Family Appliances</i> |
| Windows Hyper-V Best Practices Guide | <i>Dell EMC XC Series Best Practices for Running Windows Server 2016 with Hyper-V</i> |
| Known issues and workarounds | <i>Release Notes for XC Series Hyper-Converged Appliances</i> |
| Support Matrix | <i>Dell EMC XC6420 Series Hyper-Converged Appliance Support Matrix</i> |
| Troubleshooting your system | Troubleshooting Guide at Dell.com/poweredge manuals |

Technical specifications

The technical and environmental specifications of your system are outlined in this section.

Topics:

- Dimensions of the XC6420 Series sled
- Chassis weight
- Processor specifications
- System battery
- Expansion bus specifications
- Memory specifications
- Hard drives and storage specifications
- Video specifications
- Environmental specifications

Dimensions of the XC6420 Series sled

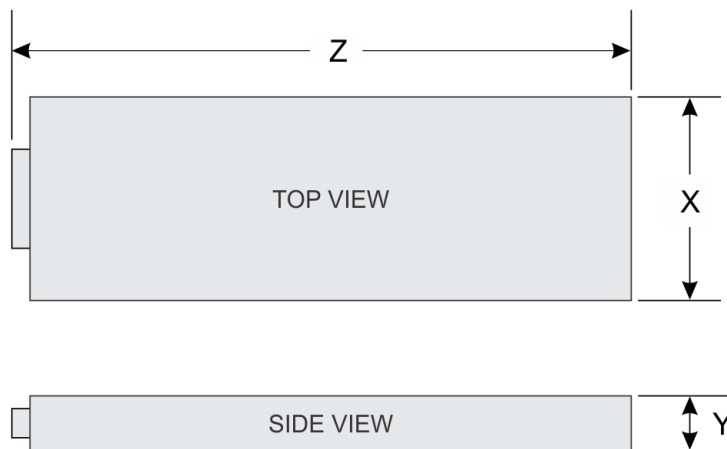

Figure 7. Dimensions of the XC6420 Series sled

Table 5. Dimensions of the XC6420 Series sled

| X | Y | Z |
|------------------------|-----------------------|-------------------------|
| 17.44 mm (6.86 inches) | 4.05 mm (1.59 inches) | 57.45 mm (22.61 inches) |

Chassis weight

Table 6. Chassis weight of the XC6420 Series sleds

| System | Maximum weight (with all the sleds and drives) |
|----------------------------------|--|
| 24 x 2.5-inch hard drive systems | 41.46 Kg (91.40 lb) |
| No backplane systems | 34.56 Kg (76.19 lb) |

Processor specifications

The XC6420 Series sled supports up to two Intel Xeon Scalable E5-2600 product family processors in each of the four independent sleds. Each processor supports up to 28 cores.

System battery

The XC6420 Series sled uses a CR 2032 3V replaceable lithium coin cell battery.

Expansion bus specifications

The XC6420 Series sled supports four Generation 3 capable PCIe slots. Two slots are populated with the base configuration.

Table 7. Expansion bus specifications

| PCIe Slots | Description | Form factor |
|-----------------------------|----------------------------------|---|
| x8 Mezzanine PCIe riser | Slot 1: x8 PCIe Gen3 from CPU 1 | Custom form factor |
| x8 + x8 OCP Mezzanine riser | Slot 2: x8 PCIe Gen3 from CPU 1 | Standard Open Compute Project (OCP) form factor |
| | Slot 3: x8 PCIe Gen3 from CPU 1 | |
| x16 PCIe main riser | Slot 4: x16 PCIe Gen3 CPU 1 | Standard Low Profile PCIe form factor |
| x16 buried PCIe riser | Slot 5: x16 PCIe Gen3 from CPU 2 | Custom form factor |

NOTE: M.2 SATA riser is supported on the buried riser.

Memory specifications

The XC6420 Series sled supports DDR4 registered DIMMs (RDIMMs) and Load Reduced DIMMS (LRDIMMs) including 3D XPoint.

Table 8. Memory specifications

| Memory module sockets | Architecture | Memory capacity and ranking | Minimum RAM | Maximum RAM |
|-----------------------|---|--|--|--|
| Sixteen 288-pin | 2666 MT/s DDR4 RDIMMs and LRDIMMS with support for advanced ECC or memory optimized operation | <ul style="list-style-type: none">Single rank - 8 GBDual rank - 16 GBDual rank - 64 GB | <ul style="list-style-type: none">8 GB with a single processor16 GB with dual processor | <ul style="list-style-type: none">512 GB with a single processor1024 GB with dual processor |

Hard drives and storage specifications

The XC6420 Series sled supports SAS and SATA hard drives and Solid State Drives (SSDs).

Table 9. Supported drive options for the XC6420 Series sled

| Maximum number of drives in the enclosure | Maximum number of drives assigned per sled |
|---|--|
| 24 x 2.5-inch drive systems | Six SAS or SATA hard drives and SSDs per sled |
| 24 x 2.5-inch drive systems with NVMe | The NVMe backplane supports either of these configurations: <ul style="list-style-type: none">• Two NVMe drives and four SAS or SATA hard drives and SSDs per sled• Six SAS or SATA hard drives and SSDs per sled |
| M.2 SATA drive | The supported capacity of the M.2 SATA card is 120 GB |
| microSD card | One on each PCIe riser of each sled |

Table 10. Supported RAID options with M.2 SATA drives

| Options | Dual M.2 SATA drives with hardware RAID |
|----------------------------|---|
| Hardware RAID | Yes |
| RAID Mode | RAID 1 |
| Number of drives supported | 2 |
| Supported CPUs | CPU 1 and CPU 2 |

Video specifications

The XC6420 Series sled supports a Matrox G200 integrated graphics card with 16 MB RAM.

Table 11. Supported video resolution options

| Resolution | Refresh rate (Hz) | Color depth (bits) |
|-------------|-------------------|--------------------|
| 1024 x 768 | 60 | up to 24 |
| 1280 x 800 | 60 | up to 24 |
| 1280 x 1024 | 60 | up to 24 |
| 1360 x 768 | 60 | up to 24 |
| 1440 x 900 | 60 | up to 24 |

Environmental specifications

The sections below contains information about the environmental specifications of the system.

Temperature specifications

Table 12. Temperature specifications

| Temperature | Specifications |
|--|---|
| Storage | -40°C to 65°C (-40°F to 149°F) |
| Continuous operation (for altitude less than 950 m or 3117 ft) | 10°C to 35°C (50°F to 95°F) with no direct sunlight on the equipment. |
| Maximum temperature gradient (operating and storage) | 20°C/h (36°F/h) |

NOTE: Some configurations require a lower ambient temperature for more information, see the Standard operating temperature specifications.

Relative humidity specifications

Table 13. Relative humidity specifications

| Relative humidity | Specifications |
|-------------------|--|
| Storage | 5% to 95% RH with 33°C (91°F) maximum dew point. Atmosphere must be non-condensing at all times. |
| Operating | 10% to 80% relative humidity with 29°C (84.2°F) |

Maximum vibration specifications

Table 14. Maximum vibration specifications

| Maximum vibration | Specifications |
|-------------------|---|
| Operating | 0.26 Grms at 5 Hz to 350 Hz (all operation orientations). |
| Storage | 1.88 Grms at 10 Hz to 500 Hz for 15 min (all six sides tested). |

Maximum shock specifications

Table 15. Maximum shock specifications

| Maximum shock | Specifications |
|---------------|--|
| Operating | 24 executed shock pulses 6 G in the positive and negative x, y, z axis for up to 11 ms (four pulses on each side of the system). |
| Storage | Six consecutively executed shock pulses of 71 G in the positive and negative x, y, z axes for up to 2 ms (one pulse on each side of the system). |

Maximum altitude specifications

Table 16. Maximum altitude specifications

| Maximum altitude | Specifications |
|------------------|----------------------|
| Operating | 3048 m (10,000 ft) |
| Storage | 12,000 m (39,370 ft) |

Operating temperature de-rating specifications

Table 17. Operating temperature

| Operating temperature de-rating | Specifications |
|---------------------------------|--|
| Up to 35°C (95°F) | Maximum temperature is reduced by 1°C/300 m (1°F/547 ft) above 950 m (3,117 ft). |
| 35°C to 40°C (95°F to 104°F) | Maximum temperature is reduced by 1°C/175 m (1°F/319 ft) above 950 m (3,117 ft). |
| 40°C to 45°C (104°F to 113°F) | Maximum temperature is reduced by 1°C/125 m (1°F/228 |

Particulate and gaseous contamination specifications

Table 18. Particulate contamination specifications

| Particulate contamination | Specifications |
|--|---|
| Air filtration | Data center air filtration as defined by ISO Class 8 per ISO 14644-1 with a 95% upper confidence limit. |
| <p>NOTE: This condition applies only to data center environments. Air filtration requirements do not apply to IT equipment designed to be used outside a data center, in environments such as an office or factory floor.</p> | |
| <p>NOTE: Air entering the data center must have MERV11 or MERV13 filtration.</p> | |
| Conductive dust | Air must be free of conductive dust, zinc whiskers, or other conductive particles. |
| <p>NOTE: This condition applies to data center and non-data center environments.</p> | |
| Corrosive dust | Air must be free of corrosive dust. |
| Residual dust present in the air must have a deliquescent point less than 60% relative humidity. | |
| <p>NOTE: This condition applies to data center and non-data center environments.</p> | |

Table 19. Gaseous contamination specifications

| Gaseous contamination | Specifications |
|--|---|
| Copper coupon corrosion rate | <300 Å/month per Class G1 as defined by ANSI/ISA71.04-1985. |
| Silver coupon corrosion rate | <200 Å/month as defined by AHSRAE TC9.9. |
| <p>NOTE: Maximum corrosive contaminant levels measured at ≤50% relative humidity.</p> | |

Standard operating temperature specifications

- NOTE:**
 - 1 Not available: Indicates that the configuration is not offered by Dell EMC.
 - 2 Not supported: Indicates that the configuration is not thermally supported.
- NOTE:** All components including the DIMMs, communication cards, M.2 SATA, and PERC cards can be supported with sufficient thermal margin if the ambient temperature is equal to or below to the maximum continuous operating temperature listed in these tables with the exception of the Mellanox DP LP card.

Table 20. Standard operating temperature specifications

| Standard operating temperature | Specifications |
|--|---|
| Temperature ranges (for altitude less than 950 m or 3117 ft) | 10°C to 35°C (50°F to 95°F) with no direct sunlight on the equipment. |

NOTE: Some configurations require a lower ambient temperature. For more information see the following tables.

Table 21. Maximum continuous operating temperature for non-fabric dual processor configuration

| TDP (W) | Processor model number | Supported heat sinks | Max DIMM count per CPU | 24x 2.5" HDDs enclosure | 20x 2.5" HDDs enclosure | 16x 2.5" HDDs enclosure | 12x 2.5" HDDs enclosure | 8x 2.5" HDDs enclosure | 4x 2.5" HDDs enclosure |
|---------|------------------------|------------------------------------|------------------------|-------------------------|-------------------------|-------------------------|-------------------------|------------------------|------------------------|
| 205W | 8180 | CPU1: FMM2M CPU2: V2DRD | CPU1: 6 CPU2: 8 | Not supported | | 21°C/ 69.8°F | 21°C/ 69.8°F | 21°C/ 69.8°F | 21°C/ 69.8°F |
| | 8180M | CPU1: FMM2M CPU2: V2DRD | CPU1: 6 CPU2: 8 | | | 21°C/ 69.8°F | 21°C/ 69.8°F | 21°C/ 69.8°F | 21°C/ 69.8°F |
| | 8168 | CPU1: FMM2M CPU2: V2DRD | CPU1: 6 CPU2: 8 | | | 21°C/ 69.8°F | 21°C/ 69.8°F | 21°C/ 69.8°F | 21°C/ 69.8°F |
| 200W | 6154 | CPU1: FMM2M CPU2: V2DRD | CPU1: 6 CPU2: 8 | | | 22°C/ 71.6°F | 22°C/ 71.6°F | 22°C/ 71.6°F | 22°C/ 71.6°F |
| 165W | 6150 | CPU1: JYKMM CPU2: V2DRD | CPU1: 8 CPU2: 8 | | | 30°C/ 86°F | 30°C/86°F | 30°C/86°F | 35°C/95°F |
| | 6146 | CPU1: JYKMM CPU2: V2DRD | CPU1: 6 CPU2: 8 | | | 30°C/ 86°F | 30°C/86°F | 30°C/86°F | 35°C/95°F |
| | 8176 | CPU1: JYKMM CPU2: V2DRD | CPU1: 8 CPU2: 8 | | | 30°C/ 86°F | 30°C/86°F | 30°C/86°F | 35°C/95°F |
| | 8176M | CPU1: JYKMM CPU2: V2DRD | CPU1: 8 CPU2: 8 | | | 30°C/ 86°F | 30°C/86°F | 30°C/86°F | 35°C/95°F |
| | 8170M | CPU1: JYKMM CPU2: V2DRD | CPU1: 8 CPU2: 8 | | | 30°C/ 86°F | 30°C/86°F | 30°C/86°F | 35°C/95°F |

| TDP (W) | Processor model number | Supported heat sinks | Max DIMM count per CPU | 24x 2.5" HDDs enclosure | 20x 2.5" HDDs enclosure | 16x 2.5" HDDs enclosure | 12x 2.5" HDDs enclosure | 8x 2.5" HDDs enclosure | 4x 2.5" HDDs enclosure |
|---------|------------------------|------------------------------------|------------------------|-------------------------|-------------------------|-------------------------|-------------------------|------------------------|------------------------|
| | 8170 | CPU1: JYKMM CPU2: V2DRD | CPU1: 8 CPU2: 8 | | | 30°C/ 86°F | 30°C/86°F | 30°C/86°F | 35°C/95°F |
| 155W | 6144 | CPU1: FMM2M CPU2: V2DRD | CPU1: 6 CPU2: 8 | Not supported | 30°C/86°F | 30°C/ 86°F | 30°C/86°F | 30°C/86°F | 35°C/95°F |
| 150W | 6148 | CPU1: JYKMM CPU2: V2DRD | CPU1: 8 CPU2: 8 | 30°C/ 86°F | 30°C/86°F | 30°C/ 86°F | 30°C/86°F | 30°C/86°F | 35°C/95°F |
| | 6142 | CPU1: FMM2M CPU2: V2DRD | CPU1: 8 CPU2: 8 | 30°C/ 86°F | 30°C/86°F | 30°C/ 86°F | 30°C/86°F | 30°C/86°F | 35°C/95°F |
| | 6136 | CPU1: JYKMM CPU2: V2DRD | CPU1: 8 CPU2: 8 | 30°C/ 86°F | 30°C/86°F | 30°C/ 86°F | 30°C/86°F | 30°C/86°F | 35°C/95°F |
| | 8164 | CPU1: JYKMM CPU2: V2DRD | CPU1: 8 CPU2: 8 | 30°C/ 86°F | 30°C/86°F | 30°C/ 86°F | 30°C/86°F | 30°C/86°F | 35°C/95°F |
| | 8160M | CPU1: JYKMM CPU2: V2DRD | CPU1: 8 CPU2: 8 | 30°C/ 86°F | 30°C/86°F | 30°C/ 86°F | 30°C/86°F | 30°C/86°F | 35°C/95°F |
| | 8160 | CPU1: JYKMM CPU2: V2DRD | CPU1: 8 CPU2: 8 | 30°C/ 86°F | 30°C/86°F | 30°C/ 86°F | 30°C/86°F | 30°C/86°F | 35°C/95°F |
| 140W | 6132 | CPU1: JYKMM CPU2: V2DRD | CPU1: 8 CPU2: 8 | 30°C/ 86°F | 30°C/86°F | 30°C/ 86°F | 30°C/86°F | 30°C/86°F | 35°C/95°F |
| | 6152 | CPU1: JYKMM CPU2: V2DRD | CPU1: 8 CPU2: 8 | 30°C/ 86°F | 30°C/86°F | 30°C/ 86°F | 30°C/86°F | 30°C/86°F | 35°C/95°F |
| | 6140M | CPU1: JYKMM CPU2: V2DRD | CPU1: 8 CPU2: 8 | 30°C/ 86°F | 30°C/86°F | 30°C/ 86°F | 30°C/86°F | 30°C/86°F | 35°C/95°F |
| | 6140 | CPU1: JYKMM | CPU1: 8 CPU2: 8 | 30°C/ 86°F | 30°C/86°F | 30°C/ 86°F | 30°C/86°F | 30°C/86°F | 35°C/95°F |

| TDP (W) | Processor model number | Supported heat sinks | Max DIMM count per CPU | 24x 2.5" HDDs enclosure | 20x 2.5" HDDs enclosure | 16x 2.5" HDDs enclosure | 12x 2.5" HDDs enclosure | 8x 2.5" HDDs enclosure | 4x 2.5" HDDs enclosure |
|---------|------------------------|--|------------------------|-------------------------|-------------------------|-------------------------|-------------------------|------------------------|------------------------|
| 130W | 6134 | CPU2: V2DRD CPU1: JYKMM CPU2: V2DRD | CPU1: 8 CPU2: 8 | 30°C/86°F | 30°C/86°F | 35°C/95°F | 35°C/95°F | 35°C/95°F | 35°C/95°F |
| 125W | 6126 | CPU1: JYKMM CPU2: V2DRD | CPU1: 8 CPU2: 8 | 30°C/86°F | 30°C/86°F | 35°C/95°F | 35°C/95°F | 35°C/95°F | 35°C/95°F |
| 8153 | | CPU1: JYKMM CPU2: V2DRD | CPU1: 8 CPU2: 8 | 30°C/86°F | 30°C/86°F | 35°C/95°F | 35°C/95°F | 35°C/95°F | 35°C/95°F |
| 6138 | | CPU1: JYKMM CPU2: V2DRD | CPU1: 8 CPU2: 8 | 30°C/86°F | 30°C/86°F | 35°C/95°F | 35°C/95°F | 35°C/95°F | 35°C/95°F |
| 6130 | | CPU1: JYKMM CPU2: V2DRD | CPU1: 8 CPU2: 8 | 30°C/86°F | 30°C/86°F | 35°C/95°F | 35°C/95°F | 35°C/95°F | 35°C/95°F |
| 115W | 6128 | CPU1: FMM2M CPU2: V2DRD | CPU1: 6 CPU2: 8 | 30°C/86°F | 30°C/86°F | 35°C/95°F | 35°C/95°F | 35°C/95°F | 35°C/95°F |
| 105W | 5122 | CPU1: FMM2M CPU2: V2DRD | CPU1: 6 CPU2: 8 | 35°C/95°F | 35°C/95°F | 35°C/95°F | 35°C/95°F | 35°C/95°F | 35°C/95°F |
| 5120 | | CPU1: JYKMM CPU2: V2DRD | CPU1: 8 CPU2: 8 | 35°C/95°F | 35°C/95°F | 35°C/95°F | 35°C/95°F | 35°C/95°F | 35°C/95°F |
| 5118 | | CPU1: JYKMM CPU2: V2DRD | CPU1: 8 CPU2: 8 | 35°C/95°F | 35°C/95°F | 35°C/95°F | 35°C/95°F | 35°C/95°F | 35°C/95°F |
| 85W | 5115 | CPU1: JYKMM CPU2: V2DRD | CPU1: 8 CPU2: 8 | 35°C/95°F | 35°C/95°F | 35°C/95°F | 35°C/95°F | 35°C/95°F | 35°C/95°F |
| 4116 | | CPU1: JYKMM CPU2: V2DRD | CPU1: 8 CPU2: 8 | 35°C/95°F | 35°C/95°F | 35°C/95°F | 35°C/95°F | 35°C/95°F | 35°C/95°F |

| TDP (W) | Processor model number | Supported heat sinks | Max DIMM count per CPU | 24x 2.5" HDDs enclosure | 20x 2.5" HDDs enclosure | 16x 2.5" HDDs enclosure | 12x 2.5" HDDs enclosure | 8x 2.5" HDDs enclosure | 4x 2.5" HDDs enclosure |
|---------|------------------------|---------------------------|------------------------|-------------------------|-------------------------|-------------------------|-------------------------|------------------------|------------------------|
| | 4114 | CPU1: JYKMM CPU2: V2DRD | CPU1: 8 CPU2: 8 | 35°C/95°F | 35°C/95°F | 35°C/95°F | 35°C/95°F | 35°C/95°F | 35°C/95°F |
| | 4112 | CPU1: JYKMM CPU2: V2DRD | CPU1: 8 CPU2: 8 | 35°C/95°F | 35°C/95°F | 35°C/95°F | 35°C/95°F | 35°C/95°F | 35°C/95°F |
| | 4110 | CPU1: JYKMM CPU2: V2DRD | CPU1: 8 CPU2: 8 | 35°C/95°F | 35°C/95°F | 35°C/95°F | 35°C/95°F | 35°C/95°F | 35°C/95°F |
| | 4108 | CPU1: JYKMM CPU2: V2DRD | CPU1: 8 CPU2: 8 | 35°C/95°F | 35°C/95°F | 35°C/95°F | 35°C/95°F | 35°C/95°F | 35°C/95°F |
| | 3106 | CPU1: JYKMM CPU2: V2DRD | CPU1: 8 CPU2: 8 | 35°C/95°F | 35°C/95°F | 35°C/95°F | 35°C/95°F | 35°C/95°F | 35°C/95°F |
| | 3104 | CPU1: JYKMM CPU2: V2DRD | CPU1: 8 CPU2: 8 | 35°C/95°F | 35°C/95°F | 35°C/95°F | 35°C/95°F | 35°C/95°F | 35°C/95°F |
| 70W | 4109T | CPU1: JYKMM CPU2: V2DRD | CPU1: 8 CPU2: 8 | 35°C/95°F | 35°C/95°F | 35°C/95°F | 35°C/95°F | 35°C/95°F | 35°C/95°F |

Expanded operating temperature specifications

Table 22. Expanded operating temperature

| Expanded operating temperature | Specifications |
|--------------------------------|---|
| Continuous operation | 5°C to 40°C at 5% to 85% RH with 29°C dew point. <div style="border-left: 2px solid black; padding-left: 10px; margin-left: 20px;"> <p>NOTE: Outside the standard operating temperature (10°C to 35°C), the system can operate continuously in temperatures as low as 5°C and as high as 40°C.</p> </div> <p>For temperatures between 35°C and 40°C, de-rate maximum allowable temperature by 1°C per 175 m above 950 m (1°F per 319 ft).</p> |
| ≤ 1% of annual operating hours | -5°C to 45°C at 5% to 90% RH with 29°C dew point. |

i | **NOTE:** Outside the standard operating temperature (10°C to 35°C), the system can operate down to -5°C or up to 45°C for a maximum of 1% of its annual operating hours.

For temperatures between 40°C and 45°C, de-rate maximum allowable temperature by 1°C per 125 m above 950 m (1°F per 228 ft).

i | **NOTE:** When operating in the expanded temperature range, system performance may be impacted.

i | **NOTE:** When operating in the expanded temperature range, ambient temperature warnings may be reported in the System Event Log.

Initial system setup and configuration

NOTE: NVMe drive slots are 6, 7, 8, and 9. XC640-4 does not support NVMe drives.

Drive slot numbering is 0 relative for chassis. All NVMe drives are installed in the last slots. Maximum of four NVMe drives are supported.

Topics:

- [Setting up your system](#)
- [iDRAC configuration](#)
- [Methods to download firmware and drivers](#)

Setting up your system

Complete the following steps to set up your system:

About this task

NOTE: Do not change any of the factory settings.

Steps

- 1 Unpack the system.
- 2 Install the system into the rack. For more information about installing the system into the rack, see the *Rail Installation Guide* at Dell.com/XCSeriesmanuals.
- 3 Connect the peripherals to the system.
- 4 Connect the system to its electrical outlet.
- 5 Turn the system on by pressing the power button or by using iDRAC.
- 6 Turn on the attached peripherals.

For more information about setting up your system, see your *Getting Started Guide* shipped with your system.

iDRAC configuration

The Integrated Dell Remote Access Controller (iDRAC) is designed to make system administrators more productive and improve the overall availability of Dell EMC systems. iDRAC alerts administrators to system issues, helps them perform remote system management, and reduces the need for physical access to the system.

Options to set up iDRAC IP address

You must configure the initial network settings based on your network infrastructure to enable the communication to and from iDRAC.

You must use the default iDRAC IP address 192.168.0.120 to configure the initial network settings, including setting up DHCP or a static IP for iDRAC. You can set up the IP address by using one of the following interfaces:

| Interfaces | Document/Section |
|------------------------|---|
| iDRAC Settings utility | See <i>Dell Integrated Dell Remote Access Controller User's Guide</i> at Dell.com/idracmanuals |

| | |
|--|--|
| Interfaces | Document/Section |
| Dell Lifecycle Controller | See <i>Dell Lifecycle Controller User's Guide</i> at Dell.com/idracmanuals |
| iDRAC Direct and Quick Sync 2 (optional) | See <i>Dell Integrated Dell Remote Access Controller User's Guide</i> at Dell.com/idracmanuals |

NOTE: To access iDRAC, ensure that you connect the Ethernet cable to the iDRAC direct port. You can also access iDRAC through the shared LOM mode, if you have opted for a system that has the shared LOM mode enabled.

Log in to iDRAC

You can log in to iDRAC as:

- iDRAC user
- Microsoft Active Directory user
- Lightweight Directory Access Protocol (LDAP) user

If you have opted for secure default access to iDRAC, the iDRAC secure default password is available on the back of the system Information tag. If you have not opted for secure default access to iDRAC, then the default user name and password are `root` and `calvin`. You can also log in by using Single Sign-On or Smart Card.

NOTE: You must have the iDRAC credentials to log in to iDRAC.

NOTE: Ensure that you change the default user name and password after setting up the iDRAC IP address.

For more information about logging in to the iDRAC and iDRAC licenses, see the latest *Integrated Dell Remote Access Controller User's Guide* at [Dell.com/idracmanuals](https://dell.com/idracmanuals).

You can also access iDRAC by using RACADM. For more information, see the *RACADM Command Line Interface Reference Guide* at [Dell.com/idracmanuals](https://dell.com/idracmanuals).

Methods to download firmware and drivers

You can download the firmware and drivers by using any of the following methods:

Table 23. Firmware and drivers

| Methods | Location |
|--|---|
| From the Dell Support site | Dell.com/support/home |
| Using Dell Remote Access Controller Lifecycle Controller (iDRAC with LC) | Dell.com/idracmanuals |

Downloading drivers and firmware

Dell EMC recommends that you download and install the latest BIOS, drivers, and systems management firmware on your system.

Prerequisite

Ensure that you clear the web browser cache before downloading the drivers and firmware.

Steps

- 1 Go to **Dell.com/support/drivers**.
- 2 In the **Drivers & Downloads** section, type the Service Tag of your system in the **Enter a Service Tag or product ID** box, and then click **Submit**.

 **NOTE:** If you do not have the Service Tag, select **Detect Product** to allow the system to automatically detect your Service Tag, or click **View products**, and navigate to your product.

- 3 Click **Drivers & Downloads**.
The drivers that are applicable to your selection are displayed.
- 4 Download the drivers to a USB drive, CD, or DVD.

Pre-operating system management applications

Dell EMC recommends that you do not change any of the factory settings. XC Series settings are configured at the factory.

Topics:

- [Options to manage the pre-operating system applications](#)
- [System Setup](#)
- [Dell Lifecycle Controller](#)
- [Boot Manager](#)
- [PXE boot](#)

Options to manage the pre-operating system applications

Your system has the following options to manage the pre-operating system applications:

- System Setup
- Dell Lifecycle Controller
- Boot Manager
- Preboot Execution Environment (PXE)

System Setup

By using the **System Setup** screen, you can configure the BIOS settings, iDRAC settings, and device settings of your system.

i **NOTE:** Help text for the selected field is displayed in the graphical browser by default. To view the help text in the text browser, press F1.

You can access system setup by using two methods:

- Standard graphical browser—The browser is enabled by default.
- Text browser—The browser is enabled by using Console Redirection.

Viewing System Setup

To view the **System Setup** screen, perform the following steps:

- 1 Turn on, or restart your system.
- 2 Press F2 immediately after you see the following message:

```
F2 = System Setup
```

i **NOTE:** If your operating system begins to load before you press F2, wait for the system to finish booting, and then restart your system and try again.

System Setup details

The **System Setup Main Menu** screen details are explained as follows:

NOTE: The XC Series system does not support the NVDIMM-N, RAID, or UEFI settings.

| Option | Description |
|------------------------|--|
| System BIOS | Enables you to configure BIOS settings. |
| iDRAC Settings | Enables you to configure the iDRAC settings. The iDRAC settings utility is an interface to set up and configure the iDRAC parameters by using UEFI (Unified Extensible Firmware Interface). You can enable or disable various iDRAC parameters by using the iDRAC settings utility. For more information about this utility, see <i>Integrated Dell Remote Access Controller User's Guide</i> at Dell.com/idracmanuals . |
| Device Settings | Enables you to configure device settings. |

System BIOS

You can use the **System BIOS** screen to edit specific functions such as boot order, system password, setup password, PCIe NVMe RAID mode, and set the SATA enable or disable USB ports.

NOTE: The XC Series system does not support the NVDIMM-N, RAID, or UEFI settings.

Viewing System BIOS

To view the **System BIOS** screen, perform the following steps:

- 1 Turn on, or restart your system.
- 2 Press F2 immediately after you see the following message:

F2 = System Setup

NOTE: If your operating system begins to load before you press F2, wait for the system to finish booting, and then restart your system and try again.

- 3 On the **System Setup Main Menu** screen, click **System BIOS**.

System BIOS Settings details

NOTE: The XC Series system does not support the NVDIMM-N, RAID, or UEFI settings.

The **System BIOS Settings** screen details are explained as follows:

| Option | Description |
|---------------------------|--|
| System Information | Specifies information about the system such as the system model name, BIOS version, and Service Tag. |
| Memory Settings | Specifies information and options related to the installed memory. |
| Processor Settings | Specifies information and options related to the processor such as speed and cache size. |
| SATA Settings | Specifies options to enable or disable the integrated SATA controller and ports. |

| Option | Description |
|--------------------------------|--|
| NVMe Settings | Specifies options to change the NVMe settings. If the system contains the NVMe drives that you want to configure in a RAID array, you must set this field and the Embedded SATA field on the SATA Settings menu to RAID mode. You might also need to change the Boot Mode setting to UEFI . Otherwise, you should set this field to Non-RAID mode. |
| Boot Settings | Allows you to set the boot mode — BIOS or UEFI. |
| Network Settings | Specifies options to manage the UEFI network settings and boot protocols. Legacy network settings are managed from the Device Settings menu. |
| Integrated Devices | Specifies options to manage integrated device controllers and ports, specifies related features and options. |
| Serial Communication | Specifies options to manage the serial ports, related features and options. |
| System Profile Settings | Specifies options to change the processor power management settings, memory frequency. |
| System Security | Specifies options to configure the system security settings, such as system password, setup password, Trusted Platform Module (TPM) security, and UEFI secure boot. It also manages the power button on the system. |
| Redundant OS Settings | Specifies the options to configure the Redundant OS settings. |
| Miscellaneous Settings | Specifies options to change the system date and time. |

System Information

You can use the **System Information** screen to view system properties such as Service Tag, system model name, and the BIOS version.

 **NOTE:** The XC Series system does not support the NVDIMM-N, RAID, or UEFI settings.

Viewing System Information

To view the **System Information** screen, perform the following steps:

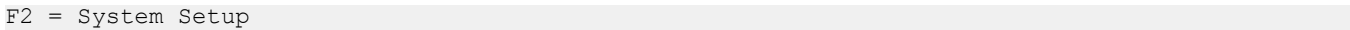
- 1 Turn on, or restart your system.
- 2 Press F2 immediately after you see the following message:

- 3 On the **System Setup Main Menu** screen, click **System BIOS**.
- 4 On the **System BIOS** screen, click **System Information**.

 **NOTE:** If your operating system begins to load before you press F2, wait for the system to finish booting, and then restart your system and try again.

System Information details

 **NOTE:** The XC Series system does not support the NVDIMM-N, RAID, or UEFI settings.

The **System Information** screen details are explained as follows:

| Option | Description |
|--------------------------|----------------------------------|
| System Model Name | Specifies the system model name. |

| Option | Description |
|--|--|
| System BIOS Version | Specifies the BIOS version installed on the system. |
| System Management Engine Version | Specifies the current version of the Management Engine firmware. |
| System Service Tag | Specifies the system Service Tag. |
| System Manufacturer | Specifies the name of the system manufacturer. |
| System Manufacturer Contact Information | Specifies the contact information of the system manufacturer. |
| System CPLD Version | Specifies the current version of the system complex programmable logic device (CPLD) firmware. |
| UEFI Compliance Version | Specifies the UEFI compliance level of the system firmware. |

Memory Settings

You can use the **Memory Settings** screen to view all the memory settings and enable or disable specific memory functions, such as system memory testing and node interleaving.

 **NOTE:** The XC Series system does not support the NVDIMM-N, RAID, or UEFI settings.

Viewing Memory Settings

To view the **Memory Settings** screen, perform the following steps:

- 1 Turn on, or restart your system.
- 2 Press F2 immediately after you see the following message:

```
F2 = System Setup
```
- 3 On the **System Setup Main Menu** screen, click **System BIOS**.
- 4 On the **System BIOS** screen, click **Memory Settings**.

 **NOTE:** If your operating system begins to load before you press F2, wait for the system to finish booting, and then restart your system and try again.

Memory Settings details

The **Memory Settings** screen details are explained as follows:

| Option | Description |
|----------------------------|---|
| System Memory Size | Specifies the memory size in the system. |
| System Memory Type | Specifies the type of memory installed in the system. |
| System Memory Speed | Specifies the system memory speed. |

| Option | Description |
|---|--|
| System Memory Voltage | Specifies the system memory voltage. |
| Video Memory | Specifies the amount of video memory. |
| System Memory Testing | Specifies whether the system memory tests are run during system boot. Options are Enabled and Disabled . This option is set to Disabled by default. |
| Memory Operating Mode | <p>Specifies the memory operating mode. The options available are Optimizer Mode, Single Rank Spare Mode, Multi Rank Spare Mode, Mirror Mode, and Dell Fault Resilient Mode. This option is set to Optimizer Mode by default.</p> <p>NOTE: The Memory Operating Mode option can have different default and available options based on the memory configuration of your system.</p> <p>NOTE: The Dell Fault Resilient Mode option establishes an area of memory that is fault resilient. This mode can be used by an operating system that supports the feature to load critical applications or enables the operating system kernel to maximize system availability.</p> |
| Current State of Memory Operating Mode | Specifies the current state of the memory operating mode. |
| Node Interleaving | Specifies if Non-Uniform Memory Architecture (NUMA) is supported. If this field is set to Enabled , memory interleaving is supported if a symmetric memory configuration is installed. If the field is set to Disabled , the system supports NUMA (asymmetric) memory configurations. This option is set to Disabled by default. |

Processor Settings

You can use the **Processor Settings** screen to view the processor settings, and perform specific functions such as enabling virtualization technology, hardware prefetcher, logical processor idling, and opportunistic self-refresh.

Viewing Processor Settings

To view the **Processor Settings** screen, perform the following steps:

- 1 Turn on, or restart your system.
- 2 Press F2 immediately after you see the following message:

F2 = System Setup

NOTE: If your operating system begins to load before you press F2, wait for the system to finish booting, and then restart your system and try again.

- 3 On the **System Setup Main Menu** screen, click **System BIOS**.
- 4 On the **System BIOS** screen, click **Processor Settings**.

Processor Settings details

The **Processor Settings** screen details are explained as follows:

| Option | Description |
|--------------------------|--|
| Logical Processor | Enables or disables the logical processors and displays the number of logical processors. If this option is set to Enabled , the BIOS displays all the logical processors. If this option is set to Disabled , the BIOS displays only one logical processor per core. This option is set to Enabled by default. |

| Option | Description |
|--------------------------------------|--|
| Virtualization Technology | Enables you to control the QuickPath Interconnect data rate settings. |
| Adjacent Cache Line Prefetch | Optimizes the system for applications that need high utilization of sequential memory access. This option is set to Enabled by default. You can disable this option for applications that need high utilization of random memory access. |
| Hardware Prefetcher | Enables or disables the hardware prefetcher. This option is set to Enabled by default. |
| DCU Streamer Prefetcher | Enables or disables the Data Cache Unit (DCU) streamer prefetcher. This option is set to Enabled by default. |
| DCU IP Prefetcher | Enables or disables the Data Cache Unit (DCU) IP prefetcher. This option is set to Enabled by default. |
| Sub NUMA Cluster | Enables or disables the Sub NUMA Cluster. This option is set to Disabled by default. |
| Logical Processor Idling | Enables you to improve the energy efficiency of a system. It uses the operating system core parking algorithm and parks some of the logical processors in the system which in turn allows the corresponding processor cores to transition into a lower power idle state. This option can only be enabled if the operating system supports it. It is set to Disabled by default. |
| X2APIC Mode | Enables or disables the X2APIC mode. This option is set to Disabled by default. |
| Dell Controlled Turbo | Controls the turbo engagement. Enable this option only when System Profile is set to Disabled . |
| Number of Cores per Processor | Controls the number of enabled cores in each processor. This option is set to All by default. |
| Processor Core Speed | Specifies the maximum core frequency of the processor. |
| Processor n | <p> NOTE: Depending on the number of processors, there might be up to four processors listed.</p> |

The following settings are displayed for each processor installed in the system:

| Option | Description |
|------------------------------|---|
| Family-Model-Stepping | Specifies the family, model, and stepping of the processor as defined by Intel. |
| Brand | Specifies the brand name. |
| Level 2 Cache | Specifies the total L2 cache. |
| Level 3 Cache | Specifies the total L3 cache. |
| Number of Cores | Specifies the number of cores per processor. |

SATA Settings

You can use the **SATA Settings** screen to view the SATA settings of SATA devices and enable SATA on your system.

 **NOTE:** The XC Series system does not support the NVDIMM-N, RAID, or UEFI settings.

Viewing SATA Settings

To view the **SATA Settings** screen, perform the following steps:

- 1 Turn on, or restart your system.
- 2 Press F2 immediately after you see the following message:

F2 = System Setup

NOTE: If your operating system begins to load before you press F2, wait for the system to finish booting, and then restart your system and try again.

- 3 On the **System Setup Main Menu** screen, click **System BIOS**.
- 4 On the **System BIOS** screen, click **SATA Settings**.

SATA Settings details

NOTE: The XC Series system does not support the NVDIMM-N, RAID, or UEFI settings.

The **SATA Settings** screen details are explained as follows:

| Option | Description | | | | | | | | |
|-----------------------------|---|--------|-------------|--------------|---|-------------------|--|-----------------|---|
| Embedded SATA | Enables the embedded SATA option to be set to AHCI , or RAID modes. This option is set to AHCI by default. | | | | | | | | |
| Security Freeze Lock | Sends Security Freeze Lock command to the embedded SATA drives during POST. This option is applicable only for ATA and AHCI mode. This option is set to Enable by default. | | | | | | | | |
| Write Cache | Enables or disables the command for the embedded SATA drives during POST. This option is set to Disable by default. | | | | | | | | |
| Port A | Sets the drive type of the selected device. For the Embedded SATA settings in ATA mode, set this field to Auto to enable BIOS support. Set it to OFF to turn off BIOS support. For AHCI or RAID mode, BIOS support is always enabled. <table border="1"><thead><tr><th>Option</th><th>Description</th></tr></thead><tbody><tr><td>Model</td><td>Specifies the drive model of the selected device.</td></tr><tr><td>Drive Type</td><td>Specifies the type of drive attached to the SATA port.</td></tr><tr><td>Capacity</td><td>Specifies the total capacity of the hard drive. This field is undefined for removable media devices such as optical drives.</td></tr></tbody></table> | Option | Description | Model | Specifies the drive model of the selected device. | Drive Type | Specifies the type of drive attached to the SATA port. | Capacity | Specifies the total capacity of the hard drive. This field is undefined for removable media devices such as optical drives. |
| Option | Description | | | | | | | | |
| Model | Specifies the drive model of the selected device. | | | | | | | | |
| Drive Type | Specifies the type of drive attached to the SATA port. | | | | | | | | |
| Capacity | Specifies the total capacity of the hard drive. This field is undefined for removable media devices such as optical drives. | | | | | | | | |
| Port B | Sets the drive type of the selected device. For the Embedded SATA settings in ATA mode, set this field to Auto to enable BIOS support. Set it to OFF to turn off BIOS support. For AHCI or RAID mode, BIOS support is always enabled. <table border="1"><thead><tr><th>Option</th><th>Description</th></tr></thead><tbody><tr><td>Model</td><td>Specifies the drive model of the selected device.</td></tr><tr><td>Drive Type</td><td>Specifies the type of drive attached to the SATA port.</td></tr><tr><td>Capacity</td><td>Specifies the total capacity of the hard drive. This field is undefined for removable media devices such as optical drives.</td></tr></tbody></table> | Option | Description | Model | Specifies the drive model of the selected device. | Drive Type | Specifies the type of drive attached to the SATA port. | Capacity | Specifies the total capacity of the hard drive. This field is undefined for removable media devices such as optical drives. |
| Option | Description | | | | | | | | |
| Model | Specifies the drive model of the selected device. | | | | | | | | |
| Drive Type | Specifies the type of drive attached to the SATA port. | | | | | | | | |
| Capacity | Specifies the total capacity of the hard drive. This field is undefined for removable media devices such as optical drives. | | | | | | | | |
| Port C | Sets the drive type of the selected device. For the Embedded SATA settings in ATA mode, set this field to Auto to enable BIOS support. Set it to OFF to turn off BIOS support. | | | | | | | | |

| | | | | | | | | | |
|-------------------|---|---------------|--------------------|--------------|---|-------------------|--|-----------------|---|
| Option | <p>Description</p> <p>For AHCI or RAID mode, BIOS support is always enabled.</p> <table border="0"> <tr> <td style="vertical-align: top;">Option</td> <td>Description</td> </tr> <tr> <td>Model</td> <td>Specifies the drive model of the selected device.</td> </tr> <tr> <td>Drive Type</td> <td>Specifies the type of drive attached to the SATA port.</td> </tr> <tr> <td>Capacity</td> <td>Specifies the total capacity of the hard drive. This field is undefined for removable media devices such as optical drives.</td> </tr> </table> | Option | Description | Model | Specifies the drive model of the selected device. | Drive Type | Specifies the type of drive attached to the SATA port. | Capacity | Specifies the total capacity of the hard drive. This field is undefined for removable media devices such as optical drives. |
| Option | Description | | | | | | | | |
| Model | Specifies the drive model of the selected device. | | | | | | | | |
| Drive Type | Specifies the type of drive attached to the SATA port. | | | | | | | | |
| Capacity | Specifies the total capacity of the hard drive. This field is undefined for removable media devices such as optical drives. | | | | | | | | |
| Port D | <p>Sets the drive type of the selected device. For the Embedded SATA settings in ATA mode, set this field to Auto to enable BIOS support. Set it to OFF to turn off BIOS support.</p> <p>For AHCI or RAID mode, BIOS support is always enabled.</p> <table border="0"> <tr> <td style="vertical-align: top;">Option</td> <td>Description</td> </tr> <tr> <td>Model</td> <td>Specifies the drive model of the selected device.</td> </tr> <tr> <td>Drive Type</td> <td>Specifies the type of drive attached to the SATA port.</td> </tr> <tr> <td>Capacity</td> <td>Specifies the total capacity of the hard drive. This field is undefined for removable media devices such as optical drives.</td> </tr> </table> | Option | Description | Model | Specifies the drive model of the selected device. | Drive Type | Specifies the type of drive attached to the SATA port. | Capacity | Specifies the total capacity of the hard drive. This field is undefined for removable media devices such as optical drives. |
| Option | Description | | | | | | | | |
| Model | Specifies the drive model of the selected device. | | | | | | | | |
| Drive Type | Specifies the type of drive attached to the SATA port. | | | | | | | | |
| Capacity | Specifies the total capacity of the hard drive. This field is undefined for removable media devices such as optical drives. | | | | | | | | |
| Port E | <p>Sets the drive type of the selected device. For the Embedded SATA settings in ATA mode, set this field to Auto to enable BIOS support. Set it to OFF to turn off BIOS support.</p> <p>For AHCI or RAID mode, BIOS support is always enabled.</p> <table border="0"> <tr> <td style="vertical-align: top;">Option</td> <td>Description</td> </tr> <tr> <td>Model</td> <td>Specifies the drive model of the selected device.</td> </tr> <tr> <td>Drive Type</td> <td>Specifies the type of drive attached to the SATA port.</td> </tr> <tr> <td>Capacity</td> <td>Specifies the total capacity of the hard drive. This field is undefined for removable media devices such as optical drives.</td> </tr> </table> | Option | Description | Model | Specifies the drive model of the selected device. | Drive Type | Specifies the type of drive attached to the SATA port. | Capacity | Specifies the total capacity of the hard drive. This field is undefined for removable media devices such as optical drives. |
| Option | Description | | | | | | | | |
| Model | Specifies the drive model of the selected device. | | | | | | | | |
| Drive Type | Specifies the type of drive attached to the SATA port. | | | | | | | | |
| Capacity | Specifies the total capacity of the hard drive. This field is undefined for removable media devices such as optical drives. | | | | | | | | |
| Port F | <p>Sets the drive type of the selected device. For the Embedded SATA settings in ATA mode, set this field to Auto to enable BIOS support. Set it to OFF to turn off BIOS support.</p> <p>For AHCI or RAID mode, BIOS support is always enabled.</p> <table border="0"> <tr> <td style="vertical-align: top;">Option</td> <td>Description</td> </tr> <tr> <td>Model</td> <td>Specifies the drive model of the selected device.</td> </tr> <tr> <td>Drive Type</td> <td>Specifies the type of drive attached to the SATA port.</td> </tr> <tr> <td>Capacity</td> <td>Specifies the total capacity of the hard drive. This field is undefined for removable media devices such as optical drives.</td> </tr> </table> | Option | Description | Model | Specifies the drive model of the selected device. | Drive Type | Specifies the type of drive attached to the SATA port. | Capacity | Specifies the total capacity of the hard drive. This field is undefined for removable media devices such as optical drives. |
| Option | Description | | | | | | | | |
| Model | Specifies the drive model of the selected device. | | | | | | | | |
| Drive Type | Specifies the type of drive attached to the SATA port. | | | | | | | | |
| Capacity | Specifies the total capacity of the hard drive. This field is undefined for removable media devices such as optical drives. | | | | | | | | |
| Port G | <p>Sets the drive type of the selected device. For the Embedded SATA settings in ATA mode, set this field to Auto to enable BIOS support. Set it to OFF to turn off BIOS support.</p> <p>For AHCI or RAID mode, BIOS support is always enabled.</p> <table border="0"> <tr> <td style="vertical-align: top;">Option</td> <td>Description</td> </tr> <tr> <td>Model</td> <td>Specifies the drive model of the selected device.</td> </tr> <tr> <td>Drive Type</td> <td>Specifies the type of drive attached to the SATA port.</td> </tr> </table> | Option | Description | Model | Specifies the drive model of the selected device. | Drive Type | Specifies the type of drive attached to the SATA port. | | |
| Option | Description | | | | | | | | |
| Model | Specifies the drive model of the selected device. | | | | | | | | |
| Drive Type | Specifies the type of drive attached to the SATA port. | | | | | | | | |

| Option | Description |
|-------------------|--|
| Option | Description |
| Capacity | Specifies the total capacity of the hard drive. This field is undefined for removable media devices such as optical drives. |
| Port H | Sets the drive type of the selected device. For the Embedded SATA settings in ATA mode, set this field to Auto to enable BIOS support. Set it to OFF to turn off BIOS support. For AHCI or RAID mode, BIOS support is always enabled. |
| Option | Description |
| Model | Specifies the drive model of the selected device. |
| Drive Type | Specifies the type of drive attached to the SATA port. |
| Capacity | Specifies the total capacity of the hard drive. This field is undefined for removable media devices such as optical drives. |

NVMe Settings

NOTE: The XC Series system does not support the NVMe drives with RAID.

NOTE: The XC Series system does not support the NVDIMM-N, RAID, or UEFI settings.

The NVMe settings enable you to set the NVMe drives to either **RAID** mode or **Non-RAID** mode.

NOTE: To configure these drives as RAID drives, you must set the NVMe drives and the Embedded SATA option in the SATA Settings menu to RAID mode. If not, you must set this field to Non-RAID mode.

Viewing NVMe Settings

To view the **NVMe Settings** screen, perform the following steps:

- 1 Turn on, or restart your system.
- 2 Press F2 immediately after you see the following message:
F2 = System Setup
- 3 On the **System Setup Main Menu** screen, click **System BIOS**.
- 4 On the **System BIOS** screen, click **NVMe Settings**.

NOTE: If your operating system begins to load before you press F2, wait for the system to finish booting, and then restart your system and try again.

NVMe Settings details

NOTE: The XC Series system does not support the NVMe drives with RAID.

NOTE: The XC Series system does not support the NVDIMM-N, RAID, or UEFI settings.

The NVMe Settings screen details are explained as follows:

| Option | Description |
|------------------|---|
| NVMe Mode | Enables you to set the NVMe mode. This option is set to Non RAID by default. |

Boot Settings

You can use the **Boot Settings** screen to set the boot mode to either **BIOS** or **UEFI**. It also enables you to specify the boot order.

NOTE: The **XC Series system does not support the NVDIMM-N, RAID, or UEFI settings.**

- **UEFI:** The Unified Extensible Firmware Interface (UEFI) is a new interface between operating systems and platform firmware. The interface consists of data tables with platform related information, also boot and runtime service calls that are available to the operating system and its loader. The following benefits are available when the **Boot Mode** is set to **UEFI**:
 - Support for hard drive partitions larger than 2 TB.
 - Enhanced security (e.g., UEFI Secure Boot).
 - Faster boot time.
- **BIOS:** The **BIOS Boot Mode** is the legacy boot mode. It is maintained for backward compatibility.

Viewing Boot Settings

To view the **Boot Settings** screen, perform the following steps:

- 1 Turn on, or restart your system.
- 2 Press F2 immediately after you see the following message:

F2 = System Setup

NOTE: If your operating system begins to load before you press F2, wait for the system to finish booting, and then restart your system and try again.

- 3 On the **System Setup Main Menu** screen, click **System BIOS**.
- 4 On the **System BIOS** screen, click **Boot Settings**.

Boot Settings details

NOTE: The **NVDIMM-N, RAID or UEFI settings are not supported.**

The **Boot Settings** screen details are explained as follows:

| Option | Description |
|----------------------------|---|
| Boot Mode | <p>Enables you to set the boot mode of the system.</p> <p>CAUTION: Switching the boot mode may prevent the system from booting if the operating system is not installed in the same boot mode.</p> <p>If the operating system supports UEFI, you can set this option to UEFI. Setting this field to BIOS allows compatibility with non-UEFI operating systems. This option is set to BIOS by default.</p> <p>NOTE: Setting this field to UEFI disables the BIOS Boot Settings menu.</p> |
| Boot Sequence Retry | <p>Enables or disables the Boot Sequence Retry feature. If this option is set to Enabled and the system fails to boot, the system re-attempts the boot sequence after 30 seconds. This option is set to Enabled by default.</p> |
| Hard-Disk Failover | <p>Specifies the hard drive that is booted in the event of a hard drive failure. The devices are selected in the Hard-Disk Drive Sequence on the Boot Option Setting menu. When this option is set to Disabled, only the first hard drive in the list is attempted to boot. When this option is set to Enabled, all hard drives are attempted to boot in the order selected in the Hard-Disk Drive Sequence. This option is not enabled for UEFI Boot Mode. This option is set to Disabled by default.</p> |

| Option | Description |
|------------------------------------|--|
| Boot Option Settings | Configures the boot sequence and the boot devices. |
| BIOS Boot Settings | Enables or disables BIOS boot options. NOTE: This option is enabled only if the boot mode is BIOS. |
| UEFI Boot Settings | Enables or disables UEFI Boot options. The UEFI options include PXE boot devices. NOTE: This option is enabled only if the boot mode is UEFI. |
| UEFI Boot Sequence | Enables you to change the PXE boot device order. |
| Boot Options Enable/Disable | Enables you to select the enabled or disabled PXE devices. |

Integrated Devices

You can use the **Integrated Devices** screen to view and configure the settings of all integrated devices including the video controller, integrated RAID controller, and the USB ports.

NOTE: The XC Series system does not support the NVDIMM-N, RAID, or UEFI settings.

Viewing Integrated Devices

To view the **Integrated Devices** screen, perform the following steps:

About this task

NOTE: The XC Series system does not support the NVDIMM-N, RAID, or UEFI settings.

Steps

- 1 Turn on, or restart your system.
- 2 Press F2 immediately after you see the following message:

```
F2 = System Setup
```
- 3 On the **System Setup Main Menu** screen, click **System BIOS**.
- 4 On the **System BIOS** screen, click **Integrated Devices**.

NOTE: If your operating system begins to load before you press F2, wait for the system to finish booting, and then restart your system and try again.

Integrated Devices details

The **Integrated Devices** screen details are explained as follows:

| Option | Description |
|----------------------------------|--|
| User Accessible USB Ports | Enables or disables the USB ports. Selecting All Ports Off disables all USB ports. The USB keyboard and mouse operate during boot process in certain operating systems. After the boot process is complete, the USB keyboard and mouse do not work if the ports are disabled. This option is set to All Ports On by default. |
| Internal USB Port | Enables or disables the internal USB port. This option is set to On or Off . This option is set to On by default. NOTE: The Internal SD Card Port on the PCIe riser is controlled by Internal USB Port. |

| Option | Description |
|---|---|
| iDRAC Direct USB Port | The iDRAC Direct USB port is managed by iDRAC exclusively with no host visibility. This option is set to ON or OFF . When set to OFF , iDRAC does not detect any USB devices installed in this managed port. This option is set to On by default. |
| Embedded NIC1 | Enables or disables the Embedded NIC1 port. The option is set to Enabled by default. |
| I/OAT DMA Engine | Enables or disables the I/O Acceleration Technology (I/OAT) option. I/OAT is a set of DMA features designed to accelerate network traffic and lower CPU utilization. Enable only if the hardware and software support the feature. This option is set to Disabled by default. |
| Embedded Video Controller | Enables or disables the use of Embedded Video Controller as the primary display. When set to Enabled , the Embedded Video Controller will be the primary display even if add-in graphic cards are installed. When set to Disabled , an add-in graphics card will be used as the primary display. BIOS will output displays to both the primary add-in video and the embedded video during POST and pre-boot environment. The embedded video will then be disabled right before the operating system boots. This option is set to Enabled by default.  NOTE: When there are multiple add-in graphic cards installed in the system, the first card discovered during PCI enumeration is selected as the primary video. You might have to re-arrange the cards in the slots in order to control which card is the primary video. |
| Current State of Embedded Video Controller | Displays the current state of the embedded video controller. The Current State of Embedded Video Controller option is a read-only field. If the Embedded Video Controller is the only display capability in the system (that is, no add-in graphics card is installed), then the Embedded Video Controller is automatically used as the primary display even if the Embedded Video Controller setting is set to Disabled . |
| SR-IOV Global Enable | Enables or disables the BIOS configuration of Single Root I/O Virtualization (SR-IOV) devices. This option is set to Disabled by default. |
| OS Watchdog Timer | If your system stops responding, this watchdog timer aids in the recovery of your operating system. When this option is set to Enabled , the operating system initializes the timer. When this option is set to Disabled (the default), the timer does not have any effect on the system. |
| Memory Mapped I/O above 4 GB | Enables or disables the support for the PCIe devices that require large amount of memory. Enable this option only for 64-bit operating systems. This option is set to Enabled by default. |
| Memory Mapped I/O above Base | When set to 12 TB , the system maps the MMIO base to 12 TB. Enable this option for an OS that requires 44 bit PCIe addressing. When set to 512 GB , the system maps the MMIO base to 512 GB, and reduces the maximum support for memory to less than 512 GB. Enable this option only for the 4 GPU DGMA issue. This option is set to 56 TB by default. |
| Slot Disablement | Enables or disables the available PCIe slots on your system. The slot disablement feature controls the configuration of the PCIe cards installed in the specified slot. Slots must be disabled only when the installed peripheral card prevents booting into the operating system or causes delays in system startup. If the slot is disabled, both the Option ROM and UEFI drivers are disabled. Only slots that are present on the system will be available for control. |

Table 24. Slot Disablement

| Option | Description |
|---------------|---|
| Slot 1 | Enables or disables the PCIe slot 1. This option is set to Enabled by default. |
| Slot 3 | Enables or disables or only the boot driver is disabled for the PCIe slot 3. This option is set to Enabled by default. |
| Slot 4 | Enables or disables or only the boot driver is disabled for the PCIe slot 4. This option is set to Enabled by default. |
| Slot 5 | Enables or disables or only the boot driver is disabled for the PCIe slot 5. This option is set to Enabled by default. |

| Option | Description |
|---------------|---|
| Slot 6 | Enables or disables or only the boot driver is disabled for the PCIe slot 6. This option is set to Enabled by default. |

Serial Communication

You can use the **Serial Communication** screen to view the properties of the serial communication port.

Viewing Serial Communication

To view the **Serial Communication** screen, perform the following steps:

- 1 Turn on, or restart your system.
- 2 Press F2 immediately after you see the following message:
F2 = System Setup

NOTE: If your operating system begins to load before you press F2, wait for the system to finish booting, and then restart your system and try again.

- 3 On the **System Setup Main Menu** screen, click **System BIOS**.
- 4 On the **System BIOS** screen, click **Serial Communication**.

Serial Communication details

The **Serial Communication** screen details are explained as follows:

| Option | Description |
|-------------------------------|--|
| Serial Port Address | Enables you to set the port address for serial devices. This field sets the serial port address to either COM1 or COM2 (COM1=0x3F8, COM2=0x2F8). This option is set to Serial Device1=COM2 or Serial Device 2=COM1 by default. <p>NOTE: You can use only Serial Device 2 for the Serial Over LAN (SOL) feature. To use console redirection by SOL, configure the same port address for console redirection and the serial device.</p> <p>NOTE: Every time the system boots, the BIOS syncs the serial MUX setting saved in iDRAC. The serial MUX setting can independently be changed in iDRAC. Loading the BIOS default settings from within the BIOS setup utility may not always revert the serial MUX setting to the default setting of Serial Device 1.</p> |
| Failsafe Baud Rate | Specifies the failsafe baud rate for console redirection. The BIOS attempts to determine the baud rate automatically. This failsafe baud rate is used only if the attempt fails, and the value is not changed. This option is set to 115200 by default. |
| Remote Terminal Type | Sets the remote console terminal type. This option is set to VT100/VT220 by default. |
| Redirection After Boot | Enables or disables the BIOS console redirection when the operating system is loaded. This option is set to Enabled by default. |

System Profile Settings

You can use the **System Profile Settings** screen to enable specific system performance settings such as power management.

Viewing System Profile Settings

To view the **System Profile Settings** screen, perform the following steps:

- 1 Turn on, or restart your system.
- 2 Press F2 immediately after you see the following message:

F2 = System Setup

NOTE: If your operating system begins to load before you press F2, wait for the system to finish booting, and then restart your system and try again.

- 3 On the **System Setup Main Menu** screen, click **System BIOS**.
- 4 On the **System BIOS** screen, click **System Profile Settings**.

System Profile Settings details

The **System Profile Settings** screen details are explained as follows:

| Option | Description |
|-----------------------------|--|
| System Profile | Sets the system profile. If you set the System Profile option to a mode other than Custom , the BIOS automatically sets the rest of the options. You can only change the rest of the options if the mode is set to Custom . This option is set to Performance Per Watt Optimized (DAPC) by default. DAPC is Dell Active Power Controller. Other options include Performance Per Watt (OS) , Performance Per Watt (HWPM) , Performance , and Workstation Performance . NOTE: All the parameters on the system profile setting screen are available only when the System Profile option is set to Custom. |
| CPU Power Management | Sets the CPU power management. This option is set to System DBPM (DAPC) by default. DBPM is Demand-Based Power Management. Other options include OS DBPM , Maximum Performance , and Hardware P States . |
| Memory Frequency | Sets the speed of the system memory. You can select Maximum Performance , Maximum Reliability , or a specific speed. This option is set to Maximum Performance by default. |
| Turbo Boost | Enables or disables the processor to operate in the turbo boost mode. This option is set to Enabled by default. |
| C1E | Enables or disables the processor to switch to a minimum performance state when it is idle. This option is set to Enabled by default. |
| C States | Enables or disables the processor to operate in all available power states. This option is set to Enabled by default. |
| Write Data CRC | Enables or disables the Write Data CRC. This option is set to Enabled by default. |
| Memory Patrol Scrub | Sets the memory patrol scrub frequency. This option is set to Standard by default. |
| Memory Refresh Rate | Sets the memory refresh rate to either 1x or 2x. This option is set to 1x by default. |
| Uncore Frequency | Enables you to select the Processor Uncore Frequency option. Dynamic mode enables the processor to optimize power resources across the cores and uncore during runtime. The optimization of the uncore frequency to either save power or optimize performance is influenced by the setting of the Energy Efficiency Policy option. |

| Option | Description |
|--|--|
| Number of Turbo Boost Enabled Cores for Processor 1 | <p>NOTE: If there are two processors installed in the system, you will see an entry for Number of Turbo Boost Enabled Cores for Processor 2.</p> <p>Controls the number of turbo boost enabled cores for Processor 1. The maximum number of cores is enabled by default.</p> |
| Monitor/Mwait | <p>Enables the Monitor/Mwait instructions in the processor. This option is set to Enabled for all system profiles, except Custom by default.</p> <p>NOTE: This option can be disabled only if the C States option in the Custom mode is set to disabled.</p> <p>NOTE: When C States is set to Enabled in the Custom mode, changing the Monitor/Mwait setting does not impact the system power or performance.</p> |
| CPU Interconnect Bus Link Power Management | Enables or disables the CPU Interconnect Bus Link Power Management. This option is set to Enabled by default. |
| PCI ASPM L1 Link Power Management | Enables or disables the PCI ASPM L1 Link Power Management. This option is set to Enabled by default. |

System Security

You can use the **System Security** screen to perform specific functions such as setting the system password, setup password and disabling the power button.

Viewing System Security

To view the **System Security** screen, perform the following steps:



- 1 Turn on, or restart your system.
- 2 Press F2 immediately after you see the following message:

- 3 On the **System Setup Main Menu** screen, click **System BIOS**.
- 4 On the **System BIOS** screen, click **System Security**.

NOTE: If your operating system begins to load before you press F2, wait for the system to finish booting, and then restart your system and try again.

System Security Settings details

The **System Security Settings** screen details are explained as follows:

| Option | Description |
|--|---|
| In-Band Manageability Interface | <p>When set to Disabled, this setting will hide the Management Engine's (ME), HECI devices, and the system's IPMI devices from the operating system. This prevents the operating system from changing the ME power capping settings, and blocks access to all in-band management tools. All management should be managed through out-of-band. This option is set to Enabled by default.</p> <p>NOTE: BIOS update requires HECI devices to be operational and DUP updates require IPMI interface to be operational. This setting needs to be set to Enabled to avoid updating errors.</p> |

| Option | Description | | | | |
|---|---|---------|-------------|------------------|---|
| Intel(R) AES-NI | Improves the speed of applications by performing encryption and decryption by using the Advanced Encryption Standard Instruction Set (AES-NI). This option is set to Enabled by default. | | | | |
| System Password | Sets the system password. This option is set to Enabled by default and is read-only if the password jumper is not installed in the system. | | | | |
| Setup Password | Sets the setup password. This option is read-only if the password jumper is not installed in the system. | | | | |
| Password Status | Locks the system password. This option is set to Unlocked by default. | | | | |
| TPM Security | <p> NOTE: The TPM menu is available only when the TPM module is installed.</p> <p>Enables you to control the reporting mode of the TPM. The TPM Security option is set to Off by default. You can only modify the TPM Status, TPM Activation, and the Intel TXT fields if the TPM Status field is set to either On with Pre-boot Measurements or On without Pre-boot Measurements.</p> | | | | |
| TPM Information | Changes the operational state of the TPM. This option is set to No Change by default. | | | | |
| TPM Status | Specifies the TPM status. | | | | |
| TPM Command | <p>Controls the Trusted Platform Module (TPM). When set to None, no command is sent to the TPM. When set to Activate, the TPM is enabled and activated. When set to Deactivate, the TPM is disabled and deactivated. When set to Clear, all the contents of the TPM are cleared. This option is set to None by default.</p> <p> CAUTION: Clearing the TPM results in the loss of all keys in the TPM. The loss of TPM keys may affect booting to the operating system.</p> <p>This field is read-only when TPM Security is set to Off. The action requires an additional reboot before it can take effect.</p> | | | | |
| Intel(R) TXT | Enables or disables the Intel Trusted Execution Technology (TXT) option. To enable the Intel TXT option, virtualization technology and TPM Security must be enabled with Pre-boot measurements. This option is set to Off by default. | | | | |
| Power Button | Enables or disables the power button on the front of the system. This option is set to Enabled by default. | | | | |
| AC Power Recovery | Sets how the system behaves after AC power is restored to the system. This option is set to Last by default. | | | | |
| AC Power Recovery Delay | Sets the time delay for the system to power up after AC power is restored to the system. This option is set to Immediate by default. | | | | |
| User Defined Delay (60 s to 240 s) | Sets the User Defined Delay option when the User Defined option for AC Power Recovery Delay is selected. | | | | |
| UEFI Variable Access | Provides varying degrees of securing UEFI variables. When set to Standard (the default), UEFI variables are accessible in the operating system per the UEFI specification. When set to Controlled , selected UEFI variables are protected in the environment and new UEFI boot entries are forced to be at the end of the current boot order. | | | | |
| Secure Boot | Enables Secure Boot, where the BIOS authenticates each pre-boot image by using the certificates in the Secure Boot Policy. Secure Boot is set to Disabled by default. | | | | |
| Secure Boot Policy | When Secure Boot policy is set to Standard , the BIOS uses the system manufacturer's key and certificates to authenticate pre-boot images. When Secure Boot policy is set to Custom , the BIOS uses the user-defined key and certificates. Secure Boot policy is set to Standard by default. | | | | |
| Secure Boot Mode | <p>Configures how the BIOS uses the Secure Boot Policy Objects (PK, KEK, db, dbx).</p> <p>If the current mode is set to Deployed Mode, the available options are User Mode and Deployed Mode. If the current mode is set to User Mode, the available options are User Mode, Audit Mode, and Deployed Mode.</p> <table border="1"> <thead> <tr> <th>Options</th> <th>Description</th> </tr> </thead> <tbody> <tr> <td>User Mode</td> <td>In User Mode, PK must be installed, and BIOS performs signature verification on programmatic attempts to update policy objects.</td> </tr> </tbody> </table> | Options | Description | User Mode | In User Mode , PK must be installed, and BIOS performs signature verification on programmatic attempts to update policy objects. |
| Options | Description | | | | |
| User Mode | In User Mode , PK must be installed, and BIOS performs signature verification on programmatic attempts to update policy objects. | | | | |

| Option | Description |
|---|--|
| Options | Description The BIOS allows unauthenticated programmatic transitions between modes. |
| Audit Mode | In Audit mode , PK is not present. The BIOS does not authenticate programmatic updates to the policy objects, and transitions between modes. Audit Mode is useful for programmatically determining a working set of policy objects. BIOS performs signature verification on pre-boot images and logs results in the image Execution Information Table, but executes the images whether they pass or fail verification. |
| Deployed Mode | Deployed Mode is the most secure mode. In Deployed Mode , PK must be installed and the BIOS performs signature verification on programmatic attempts to update policy objects. Deployed Mode restricts the programmatic mode transitions. |
| Secure Boot Policy Summary | Specifies the list of certificates and hashes that secure boot uses to authenticate images. |
| Secure Boot Custom Policy Settings | Configures the Secure Boot Custom Policy. To enable this option, set the Secure Boot Policy to Custom option. |

Creating a system and setup password

Prerequisite

Ensure that the password jumper is enabled. The password jumper enables or disables the system password and setup password features. For more information, see [System board jumper settings](#).

NOTE: If the password jumper setting is disabled, the existing system password and setup password are deleted and you need not provide the system password to boot the system.

Steps

- To enter System Setup, press F2 immediately after turning on or rebooting your system.
- On the **System Setup Main Menu** screen, click **System BIOS > System Security**.
- On the **System Security** screen, verify that **Password Status** is set to **Unlocked**.
- In the **System Password** field, type your system password, and press Enter or Tab.
Use the following guidelines to assign the system password:system password:
 - A password can have up to 32 characters.
 - The password can contain the numbers 0 through 9.
 - Only the following special characters are allowed: space, ("), (+), (,), (-), (.), (/), (:), ([), (\), (]), (`).

A message prompts you to reenter the system password.
- Reenter the system password, and click **OK**.
- In the **Setup Password** field, type your setup password and press Enter or Tab.
A message prompts you to reenter the setup password.
- Reenter the setup password, and click **OK**.
- Press Esc to return to the System BIOS screen. Press Esc again.

A message prompts you to save the changes.

NOTE: Password protection does not take effect until the system reboots.

Using your system password to secure your system

About this task

If you have assigned a setup password, the system accepts your setup password as an alternate system password.

Steps

- 1 Turn on or reboot your system.
- 2 Type the system password and press Enter.

Next step

When **Password Status** is set to **Locked**, type the system password and press Enter when prompted at reboot.

NOTE: If an incorrect system password is typed, the system displays a message and prompts you to reenter your password. You have three attempts to type the correct password. After the third unsuccessful attempt, the system displays an error message that the system has stopped functioning and must be turned off. Even after you turn off and restart the system, the error message is displayed until the correct password is entered.

Deleting or changing system and setup password

Prerequisite

NOTE: You cannot delete or change an existing system or setup password if the **Password Status** is set to **Locked**.

Steps

- 1 To enter System Setup, press F2 immediately after turning on or restarting your system.
- 2 On the **System Setup Main Menu** screen, click **System BIOS > System Security**.
- 3 On the **System Security** screen, ensure that **Password Status** is set to **Unlocked**.
- 4 In the **System Password** field, alter or delete the existing system password, and then press Enter or Tab.
- 5 In the **Setup Password** field, alter or delete the existing setup password, and then press Enter or Tab.
If you change the system and setup password, a message prompts you to reenter the new password. If you delete the system and setup password, a message prompts you to confirm the deletion.
- 6 Press Esc to return to the **System BIOS** screen. Press Esc again, and a message prompts you to save the changes.
- 7 Select **Setup Password**, change, or delete the existing setup password and press Enter or Tab.

NOTE: If you change the system password or setup password, a message prompts you to reenter the new password. If you delete the system password or setup password, a message prompts you to confirm the deletion.

Operating with setup password enabled

If **Setup Password** is set to **Enabled**, type the correct setup password before modifying the system setup options.

If you do not type the correct password in three attempts, the system displays the following message:

```
Invalid Password! Number of unsuccessful password attempts: <x> System Halted! Must power down.
```

```
Password Invalid. Number of unsuccessful password attempts: <x> Maximum number of password attempts exceeded. System halted.
```

Even after you turn off and restart the system, the error message is displayed until the correct password is typed. The following options are exceptions:

- If **System Password** is not set to **Enabled** and is not locked through the **Password Status** option, you can assign a system password. For more information, see [System Security Settings details](#).
- You cannot disable or change an existing system password.

NOTE: You can use the password status option with the setup password option to protect the system password from unauthorized changes.

Redundant OS Control

You can use the **Redundant OS Control** screen to set the redundant OS info for redundant OS control. It enables you to set up a physical recovery disk on your system.

Viewing Redundant OS Control

To view the **Redundant OS Control** screen, perform the following steps:

- 1 Turn on, or restart your system.
- 2 Press F2 immediately after you see the following message:
F2 = System Setup

NOTE: If your operating system begins to load before you press F2, wait for the system to finish booting, and then restart your system and try again.

- 3 On the **System Setup Main Menu** screen, click **System BIOS**.
- 4 On the **System BIOS** screen, click **Redundant OS Control**.

Redundant OS Control screen details

NOTE: The XC Series system does not support the NVDIMM-N, RAID, or UEFI settings.

The **Redundant OS Control** screen details are explained as follows:

| Option | Description |
|------------------------------|--|
| Redundant OS Location | <p>Enables you to select a backup disk from the following devices:</p> <ul style="list-style-type: none"> • None • Internal microSD card • SATA Ports in AHCI mode • M.2 drives • Internal USB <p>NOTE: RAID configurations and NVMe cards are not included as BIOS does not have the ability to distinguish between individual drives in those configurations.</p> |
| Redundant OS State | <p>NOTE: This option is disabled if Redundant OS Location is set to None.</p> <p>When set to Visible, the backup disk is visible to the boot list and OS. When set to Hidden, the backup disk is disabled and is not visible to the boot list and OS. This option is set to Visible by default.</p> <p>NOTE: BIOS disables the device in hardware, so it cannot be accessed by the OS.</p> |
| Redundant OS Boot | <p>NOTE: This option is disabled if Redundant OS Location is set to None or if Redundant OS State is set to Hidden.</p> |

| Option | Description |
|--------|---|
| | When set to Enabled , BIOS boots to the device specified in Redundant OS Location . When set to Disabled , BIOS preserves the current boot list settings. This option is set to Enabled by default. |

Miscellaneous Settings

You can use the **Miscellaneous Settings** screen to perform specific functions such as updating the asset tag and changing the system date and time.

Viewing Miscellaneous Settings

To view the **Miscellaneous Settings** screen, perform the following steps:

- 1 Turn on, or restart your system.
- 2 Press F2 immediately after you see the following message:

F2 = System Setup

NOTE: If your operating system begins to load before you press F2, wait for the system to finish booting, and then restart your system and try again.

- 3 On the **System Setup Main Menu** screen, click **System BIOS**.
- 4 On the **System BIOS** screen, click **Miscellaneous Settings**.

Miscellaneous Settings details

NOTE: The XC Series system does not support the NVDIMM-N, RAID, or UEFI settings.

The **Miscellaneous Settings** screen details are explained as follows:

| Option | Description |
|--------------------------------------|---|
| System Time | Enables you to set the time on the system. |
| System Date | Enables you to set the date on the system. |
| Asset Tag | Specifies the asset tag and enables you to modify it for security and tracking purposes. |
| Keyboard NumLock | Enables you to set whether the system boots with the NumLock enabled or disabled. This option is set to On by default. NOTE: This option does not apply to 84-key keyboards. |
| F1/F2 Prompt on Error | Enables or disables the F1/F2 prompt on error. This option is set to Enabled by default. The F1/F2 prompt also includes keyboard errors. |
| Load Legacy Video Option ROM | Enables you to determine whether the system BIOS loads the legacy video (INT 10H) option ROM from the video controller. Selecting Enabled in the operating system does not support UEFI video output standards. This field is available only for UEFI boot mode. You cannot set the option to Enabled if UEFI Secure Boot mode is enabled. |
| Dell Wyse P25/P45 BIOS Access | Enables or disables the Dell Wyse P25/P45 BIOS Access. This option is set to Enabled by default. |
| Power Cycle Request | Enables or disables the Power Cycle Request. This option is set to None by default. |

iDRAC Settings utility

The iDRAC settings utility is an interface to set up and configure the iDRAC parameters by using UEFI. You can enable or disable various iDRAC parameters by using the iDRAC settings utility.

① | **NOTE:** The XC Series system does not support the NVDIMM-N, RAID, or UEFI settings.

① | **NOTE:** Accessing some of the features on the iDRAC settings utility needs the iDRAC Enterprise License upgrade.

For more information about using iDRAC, see *Dell Integrated Dell Remote Access Controller User's Guide* at [Dell.com/idracmanuals](https://www.dell.com/idracmanuals).

Device Settings

Device Settings enables you to configure device parameters.

Dell Lifecycle Controller

Dell Lifecycle Controller (LC) provides advanced embedded systems management capabilities including system deployment, configuration, update, maintenance, and diagnosis. LC is delivered as part of the iDRAC out-of-band solution and Dell system embedded Unified Extensible Firmware Interface (UEFI) applications.

① | **NOTE:** The XC Series system does not support the NVDIMM-N, RAID, or UEFI settings.

Embedded systems management

The Dell Lifecycle Controller provides advanced embedded systems management throughout the system's lifecycle. The Dell Lifecycle Controller can be started during the boot sequence and can function independently of the operating system.

① | **NOTE:** Certain platform configurations may not support the full set of features provided by the Dell Lifecycle Controller.

For more information about setting up the Dell Lifecycle Controller, configuring hardware and firmware, and deploying the operating system, see the Dell Lifecycle Controller documentation at [Dell.com/idracmanuals](https://www.dell.com/idracmanuals).

Boot Manager

The **Boot Manager** screen enables you to select boot options and diagnostic utilities.

① | **NOTE:** The XC Series system does not support the NVDIMM-N, RAID, or UEFI settings.

Viewing Boot Manager

About this task

To enter Boot Manager:

Steps

- 1 Turn on, or restart your system.
- 2 Press F11 when you see the following message:
F11 = Boot Manager

If your operating system begins to load before you press F11, allow the system to complete the booting, and then restart your system and try again.

Boot Manager main menu

NOTE: The XC Series system does not support the NVDIMM-N, RAID, or UEFI settings.

| Menu item | Description |
|------------------------------------|---|
| Continue Normal Boot | The system attempts to boot to devices starting with the first item in the boot order. If the boot attempt fails, the system continues with the next item in the boot order until the boot is successful or no more boot options are found. |
| One-shot Boot Menu | Enables you to access boot menu, where you can select a one-time boot device to boot from. |
| Launch System Setup | Enables you to access System Setup. |
| Launch Lifecycle Controller | Exits the Boot Manager and invokes the Dell Lifecycle Controller program. |
| System Utilities | Enables you to launch System Utilities menu such as System Diagnostics and UEFI shell. |

One-shot BIOS boot menu

One-shot BIOS boot menu enables you to select a boot device to boot from.

System Utilities

System Utilities contains the following utilities that can be launched:

- Launch Diagnostics
- BIOS Update File Explorer
- Reboot System

PXE boot

You can use the Preboot Execution Environment (PXE) option to boot and configure the networked systems, remotely.

To access the **PXE boot** option, boot the system and then press F12 during POST instead of using standard Boot Sequence from BIOS Setup. It does not pull any menu or allow managing of network devices.

Installing and removing system components

Safety instructions

- ⚠ WARNING:** Whenever you need to lift the system, get others to assist you. To avoid injury, do not attempt to lift the system by yourself.
- ⚠ WARNING:** Opening or removing the system cover while the system is powered on may expose you to a risk of electric shock.
- ⚠ CAUTION:** Do not operate the system without the cover for a duration exceeding five minutes. Operating the system without the system cover can result in component damage.
- ⚠ CAUTION:** Many repairs may only be done by a certified service technician. You should only perform troubleshooting and simple repairs as authorized in your product documentation, or as directed by the online or telephone service and support team. Damage due to servicing that is not authorized by Dell is not covered by your warranty. Read and follow the safety instructions that are shipped with your product.
- ℹ NOTE:** It is recommended that you always use an antistatic mat and antistatic strap while working on components inside the system.
- ⚠ CAUTION:** To ensure proper operation and cooling, all bays in the system and system fans must be always populated with a component or a blank.

Before working inside your system

Prerequisite

Follow the safety guidelines listed in [Safety instructions](#).

Steps

- 1 Turn off the system, including all attached peripherals.
- 2 Disconnect the system from the electrical outlet and disconnect the peripherals.
- 3 Remove the sled from the enclosure.

After working inside your system

Prerequisite

Follow the safety guidelines listed in [Safety instructions](#).

Steps

- 1 Reconnect the peripherals and connect the system to the electrical outlet.
- 2 Turn on the attached peripherals and then turn on the system.

Recommended tools

You need the following tools to perform the removal and installation procedures:

- Phillips #1 screwdriver
- Phillips #2 screwdriver
- 1/4 inch flat head screwdriver

- #4 nut driver
- Torx #T30 screwdriver
- Wrist grounding strap
- ESD mat

Inside the sled

⚠ CAUTION: This system must be operated with the system cover installed to ensure proper cooling.

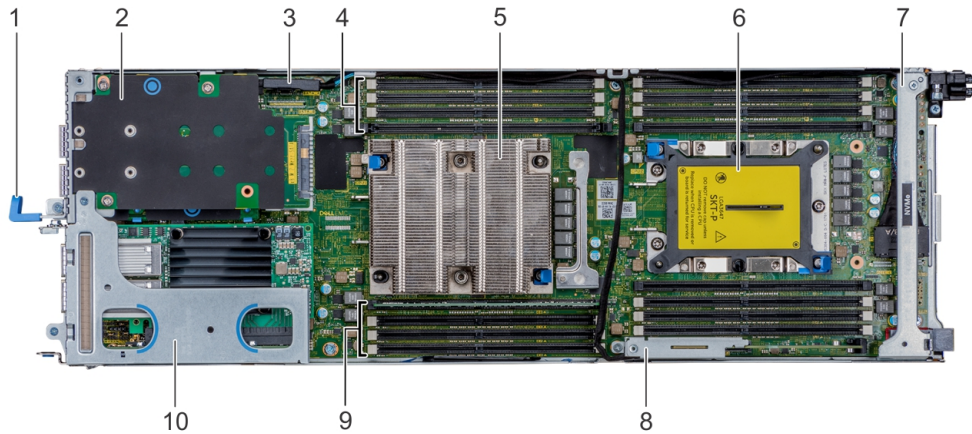

Figure 8. Inside the XC6420 sled

- | | | | |
|---|---------------------------------|----|--|
| 1 | sled pull handle | 2 | mezzanine card |
| 3 | SATA connector | 4 | memory slot (4) |
| 5 | CPU1 processor heat sink module | 6 | CPU2 processor heat sink module socket |
| 7 | supporting bracket | 8 | M.2 SATA riser |
| 9 | memory slot (4) | 10 | PCIe expansion card riser assembly |

XC6420 Series sled

The XC6420 Series sled is a server unit that is installed into the XC6400 Series enclosure. The sled features dual processors, memory, a PCIe expansion slot, mezzanine cards, and onboard storage (SD card and M.2 SATA).

Removing a sled

Prerequisites

- 1 Follow the safety guidelines listed in [Safety instructions](#).
- 2 Follow the procedure listed in [Before working inside your system](#).

ⓘ NOTE: The process of removing a sled blank is similar to removing a sled.

Step

Press the retaining latch and using the handle slide the sled out of the enclosure horizontally, ensuring that the sled is supported from beneath.

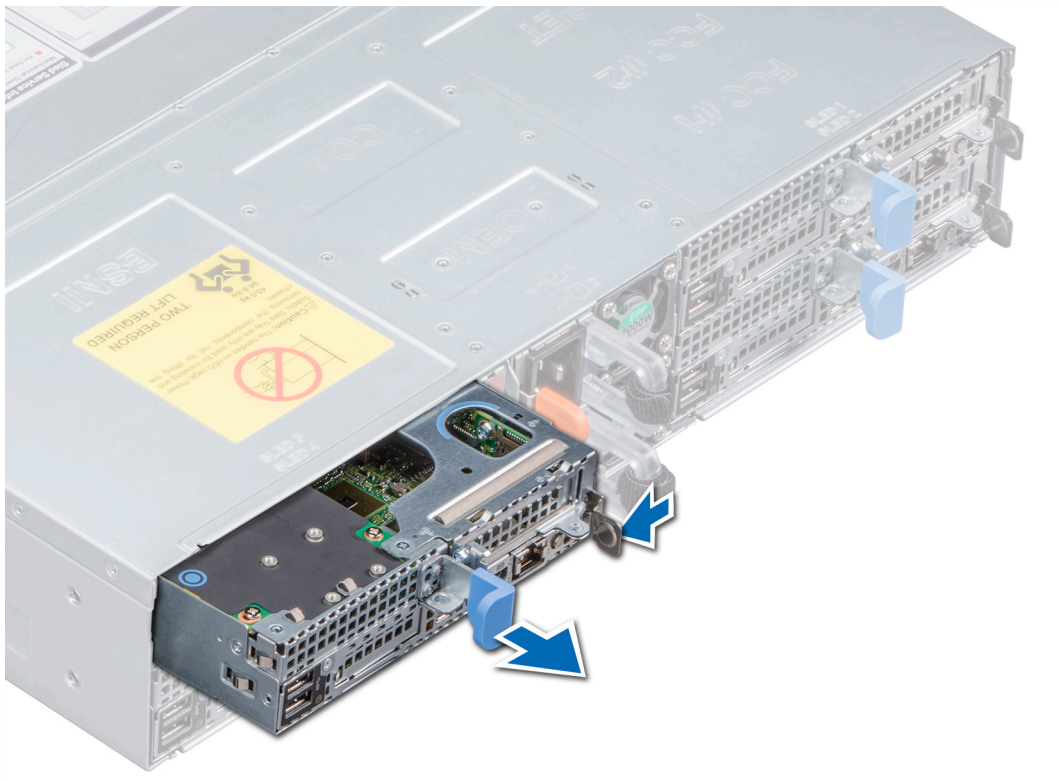

Figure 9. Removing a sled

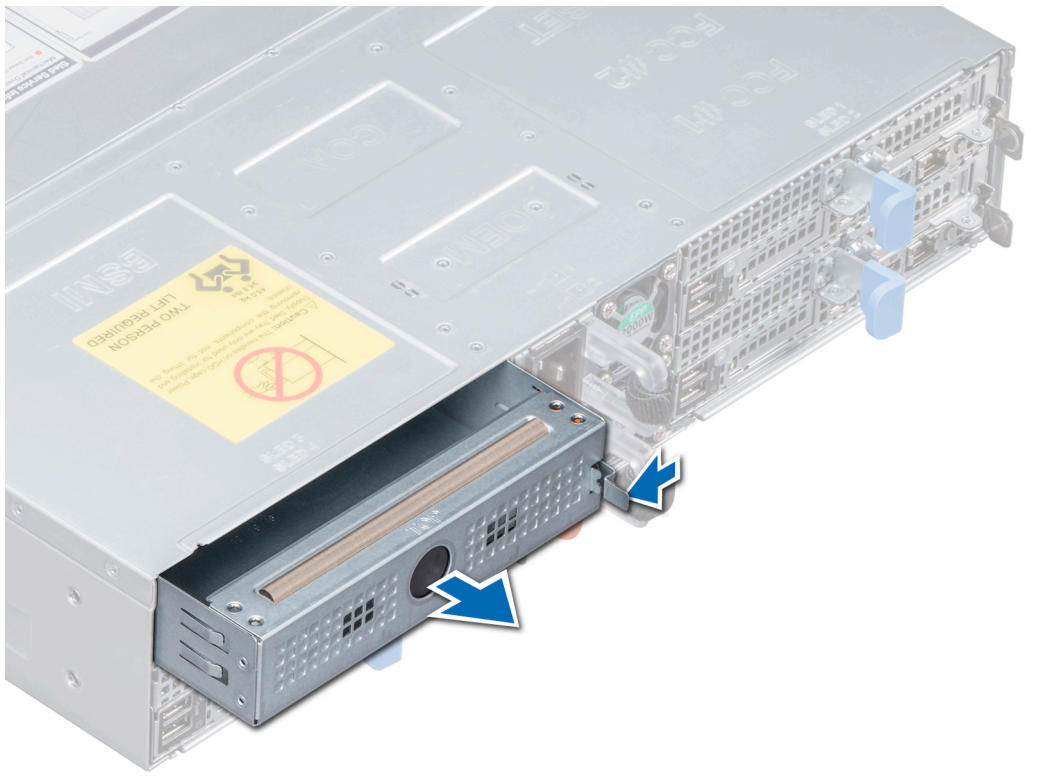

Figure 10. Removing a sled blank

Next step

Install the sled into the enclosure.

NOTE: If the sled is not being replaced immediately, a sled blank must be installed to ensure proper cooling of the system.

Installing a sled

Prerequisites

- 1 Follow the safety guidelines listed in [Safety instructions](#).
- 2 If installed, [remove the sled blank](#).

Step

Slide the sled into the enclosure horizontally, ensuring that the sled is supported from beneath until it locks into place.

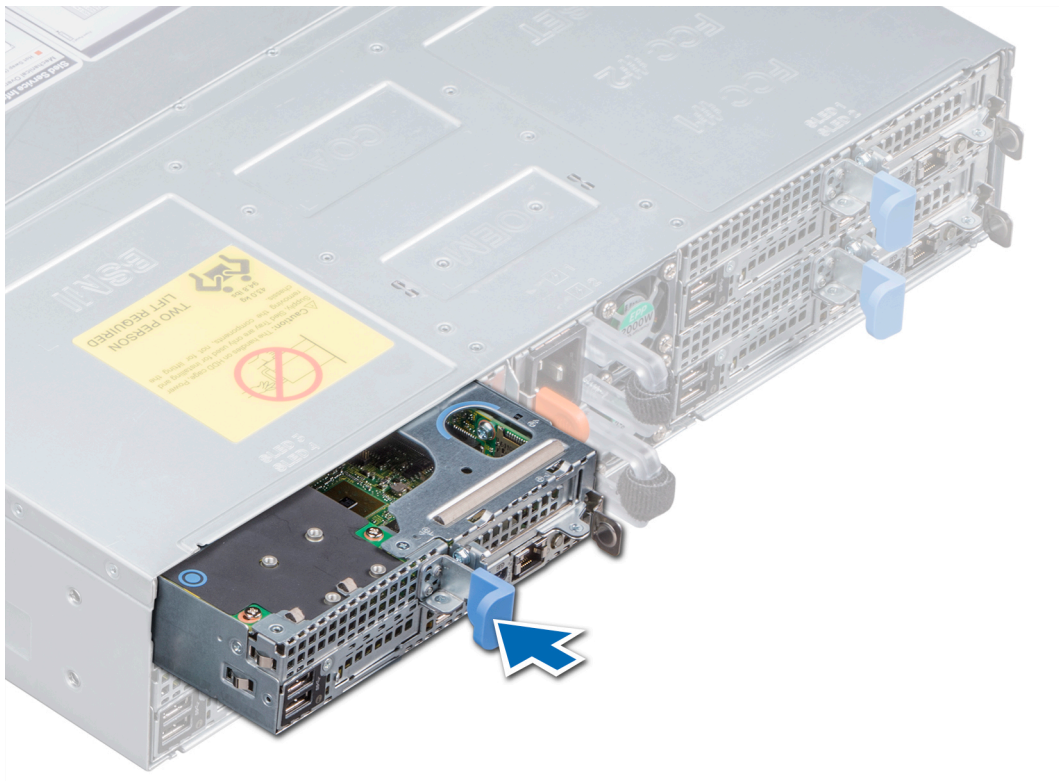

Figure 11. Installing a sled

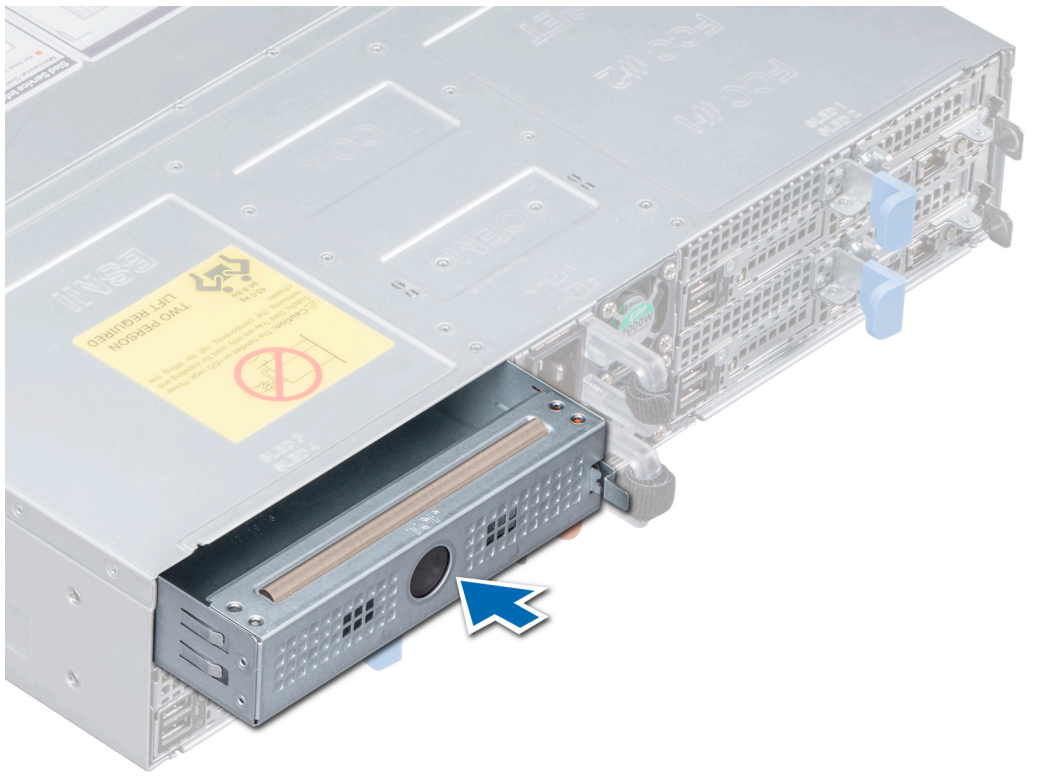

Figure 12. Installing a sled blank

Next step

Follow the procedure listed in [After working inside your system](#).

NOTE: To add the Service Tag of the system board to match the Service Tag of the physical node, contact Dell EMC Technical Support.

Air shroud

The air shroud aerodynamically directs the airflow across the sled. The airflow passes through all the critical parts of the sled, where the fans push the air across the entire surface area of the heat sink. There is a vacuum created by air pulled across the hard drives, thus allowing increased cooling.

Removing the air shroud

Prerequisites

- 1 Follow the safety guidelines listed in [Safety instructions](#).
- 2 Follow the procedure listed in [Before working inside your system](#).
- 3 [Remove the sled](#) from the enclosure.

Steps

- 1 Press the clip on the air shroud to release the shroud from the sled.
- 2 Remove the shroud by rotating the shroud and releasing the hinge from the slot on the system.

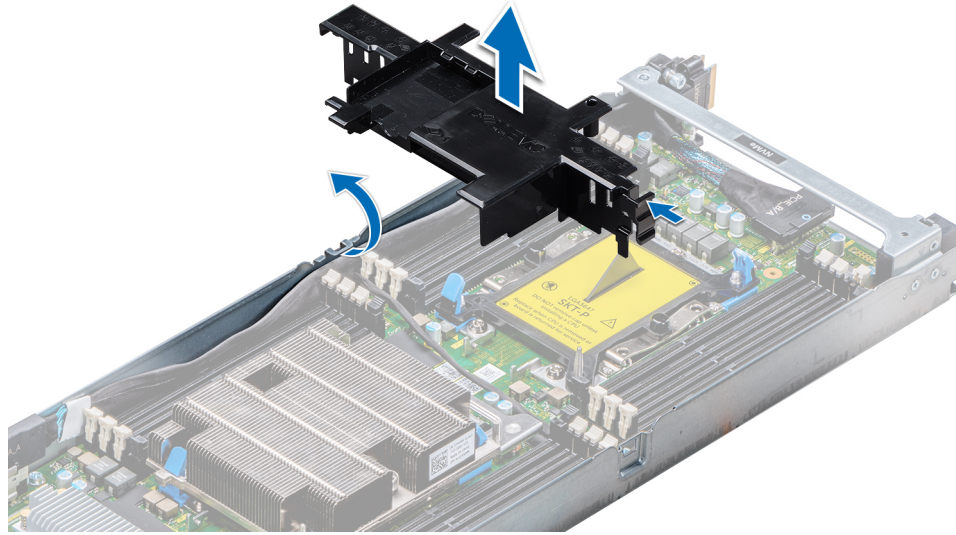

Figure 13. Removing the air shroud

Next step

Install the air shroud.

Installing the air shroud

Prerequisite

- 1 Follow the safety guidelines listed in [Safety instructions](#).

Steps

- 1 Insert the air shroud into the sled, aligning the shroud hinge with slot on the sled chassis.

NOTE: Ensure that both the SATA cables are routed through the air shroud cable guide slot behind the air shroud latches.

NOTE: Ensure that neither of the cables are pinched or pressed under the air shroud.

- 2 Press the air shroud until the locks click into place.

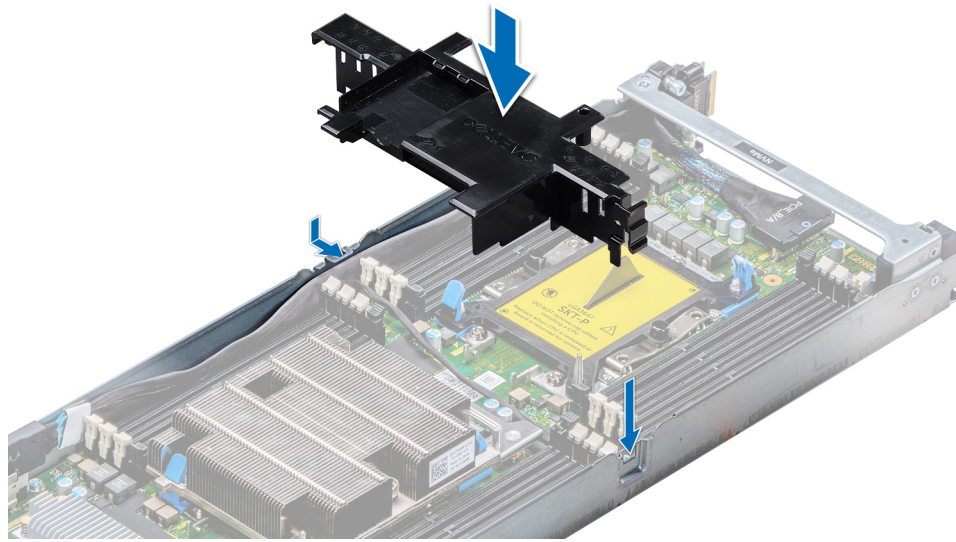

Figure 14. Installing the air shroud

Next steps

- 1 [Install the sled](#) into the enclosure.
- 2 Follow the procedure listed in [After working inside your system](#).

System memory

The system supports DDR4 registered DIMMs (RDIMMs) and load reduced DIMMs (LRDIMMs). System memory holds the instructions that are executed by the processor.

NOTE: MT/s indicates DIMM speed in MegaTransfers per second.

Memory bus operating frequency can be 2666 MT/s, 2400 MT/s, or 2133 MT/s depending on the following factors:

- DIMM type (RDIMM or LRDIMM)
- Number of DIMMs populated per channel
- System profile selected (for example, Performance Optimized, or Custom [can be run at high speed or lower])
- Maximum supported DIMM frequency of the processors

Your system contains 16 memory sockets split into two sets of 8 sockets, one set per processor. Each 8-socket set is organized into channels. In each channel, the release tabs of the first socket are marked white, the second socket black.

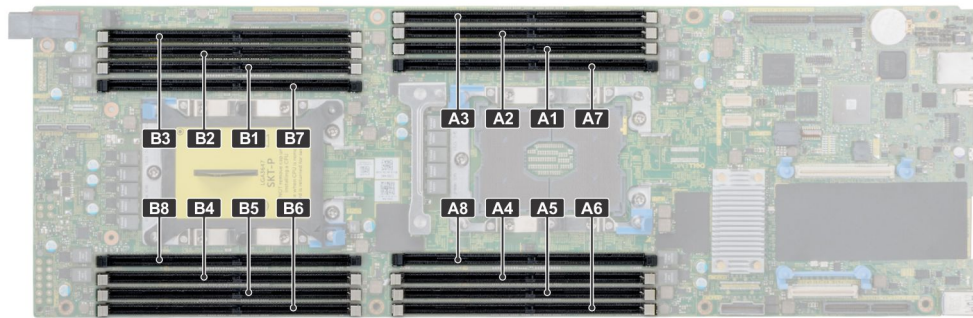

Figure 15. Memory socket locations

Memory channels are organized as follows:

Table 25. Memory channels

| Processor | Channel 0 | Channel 1 | Channel 2 | Channel 3 | Channel 4 | Channel 5 |
|-------------|-----------------|-----------|-----------|-----------------|-----------|-----------|
| Processor 1 | Slots A1 and A7 | Slots A2 | Slots A3 | Slots A8 and A4 | Slots A5 | Slots A6 |
| Processor 2 | Slots B1 and B7 | Slots B2 | Slots B3 | Slots B8 and B4 | Slots B5 | Slots B6 |

General memory module installation guidelines

NOTE: Memory configurations that fail to observe these guidelines can prevent your system from booting, stop responding during memory configuration, or operating with reduced memory.

The system supports Flexible Memory Configuration, enabling the system to be configured and run in any valid chipset architectural configuration. The following are the recommended guidelines for installing memory modules:

- RDIMMs and LRDIMMs must not be mixed.
- x4 and x8 DRAM based memory modules can be mixed. For more information, see the Mode-specific guidelines section.
- Up to two RDIMMs can be populated per channel regardless of rank count.
- Up to two LRDIMMs can be populated per channel regardless of rank count.
- If memory modules with different speeds are installed, they will operate at the speed of the slowest installed memory module(s) or slower depending on the system DIMM configuration.
- Populate memory module sockets only if a processor is installed. For dual-processor systems, sockets A1 to A8 and sockets B1 to B8 are available.
- Populate all the sockets with white release tabs first, followed by the sockets with black release tabs.
- When mixing memory modules with different capacities, populate the sockets with memory modules with highest capacity first. For example, if you want to mix 8 GB and 16 GB memory modules, populate 16 GB memory modules in the sockets with white release tabs and 8 GB memory modules in the sockets with black release tabs.
- In a dual-processor configuration, the memory configuration for each processor should be identical. For example, if you populate socket A1 for processor 1, then populate socket B1 for processor 2, and so on.
- Memory modules of different capacities can be mixed provided other memory population rules are followed (for example, 8 GB and 16 GB memory modules can be mixed).
- Mixing of more than two memory module capacities in a system is not supported.
- Populate six memory modules per processor (one DIMM per channel) at a time to maximize performance.

Mode-specific guidelines

Five memory channels are allocated to each processor. The allowable configurations depend on the memory mode selected. It is recommended to set the memory to Memory Optimized mode.

NOTE: You can mix x4 and x8 DRAM based DIMMs to support RAS features. However, all guidelines for specific RAS features must be followed. x4 DRAM based DIMMs retain Single Device Data Correction (SDDC) in memory optimized (independent channel) mode. x8 DRAM based DIMMs need Advanced ECC mode to gain SDDC.

Removing a memory module

Prerequisites

- 1 Follow the safety guidelines listed in [Safety instructions](#).
- 2 Follow the procedure listed in [Before working inside your system](#).
- 3 Remove the air shroud.

WARNING: Allow the memory modules to cool after you power off the system. Handle the memory modules by the card edges and avoid touching the components or metallic contacts on the memory module.

CAUTION: To ensure proper system cooling, memory module blanks must be installed in any memory socket that is not occupied. Remove memory module blanks only if you intend to install memory modules in those sockets.

CAUTION: To ensure proper system cooling in configurations with mid drive tray, memory module blanks must be installed in any memory socket that is not occupied. Remove memory module blanks only if you intend to install memory modules in those sockets.

Steps

- 1 Locate the appropriate memory module socket.

CAUTION: Handle each memory module only by the card edges, ensuring not to touch the middle of the memory module or metallic contacts.

- 2 Push the ejectors outward on both ends of the memory module socket to release the memory module from the socket.
- 3 Lift and remove the memory module from the system.

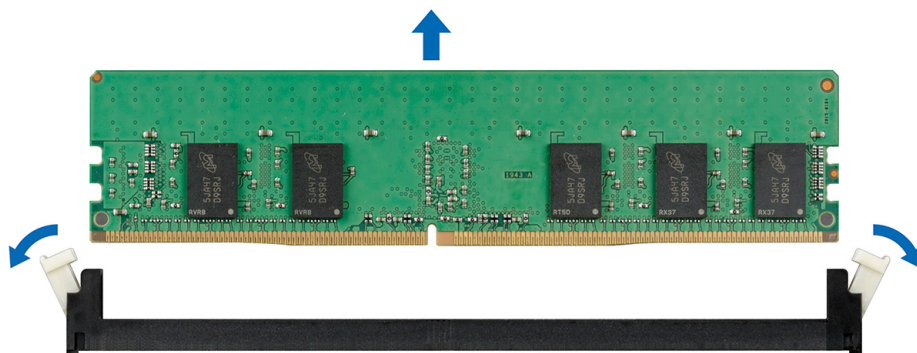

Figure 16. Removing a memory module

Next steps

- 1 [Install the memory module](#).
- 2 If you are removing the memory module permanently, install a memory module blank. The procedure to install a memory module blank is similar to that of the memory module.

Installing a memory module

Prerequisite

Follow the safety guidelines listed in [Safety instructions](#).

Steps

- 1 Locate the appropriate memory module socket.

CAUTION: Handle each memory module only by the edges, ensuring not to touch the middle of the memory module or metallic contacts.

CAUTION: To prevent damage to the memory module or the memory module socket during installation, do not bend or flex the memory module. You must insert both ends of the memory module simultaneously.

- 2 Open the ejectors on the memory module socket outward to allow the memory module to be inserted into the socket.

- 3 Align the edge connector of the memory module with the alignment key of the memory module socket, and insert the memory module in the socket.

CAUTION: Do not apply pressure at the center of the memory module; apply pressure at both ends of the memory module evenly.

NOTE: The memory module socket has an alignment key that enables you to install the memory module in the socket in only one orientation.

- 4 Press the memory module with your thumbs until the socket levers firmly click into place.

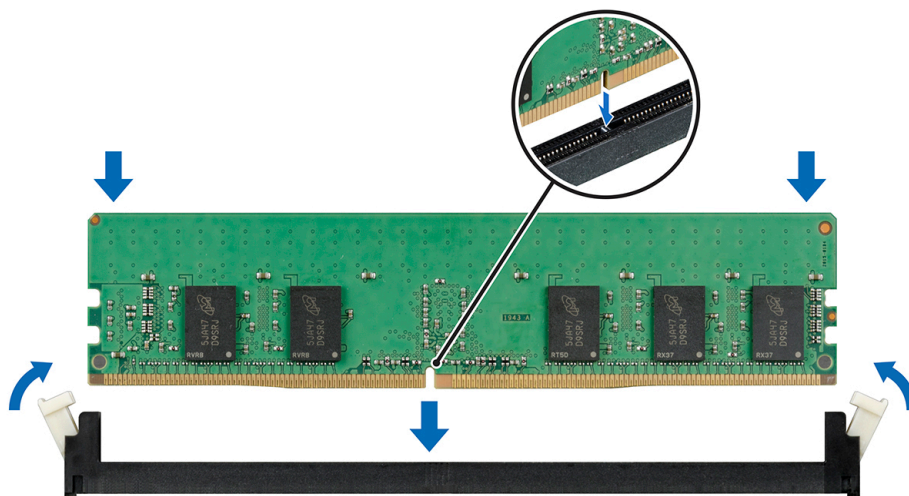

Figure 17. Installing a memory module

Next steps

- 1 [Install the air shroud](#).
- 2 Follow the procedure listed in [After working inside your system](#).
- 3 To verify if the memory module has been installed properly, press F2 and navigate to **System Setup Main Menu > System BIOS > Memory Settings**. In the **Memory Settings** screen, the System Memory Size must reflect the updated capacity of the installed memory.
- 4 If the value is incorrect, one or more of the memory modules may not be installed properly. Ensure that the memory module is firmly seated in the memory module socket.
- 5 Run the system memory test in system diagnostics.

Support bracket

Removing the support bracket

Prerequisites

- 1 Follow the safety guidelines listed in [Safety instructions](#).
- 2 Follow the procedure listed in [Before working inside your system](#).
- 3 [Remove the sled](#) from the enclosure.

Step

Using the Phillips #1 screwdriver, remove the screws that secure the support bracket and lift the bracket away from the sled.

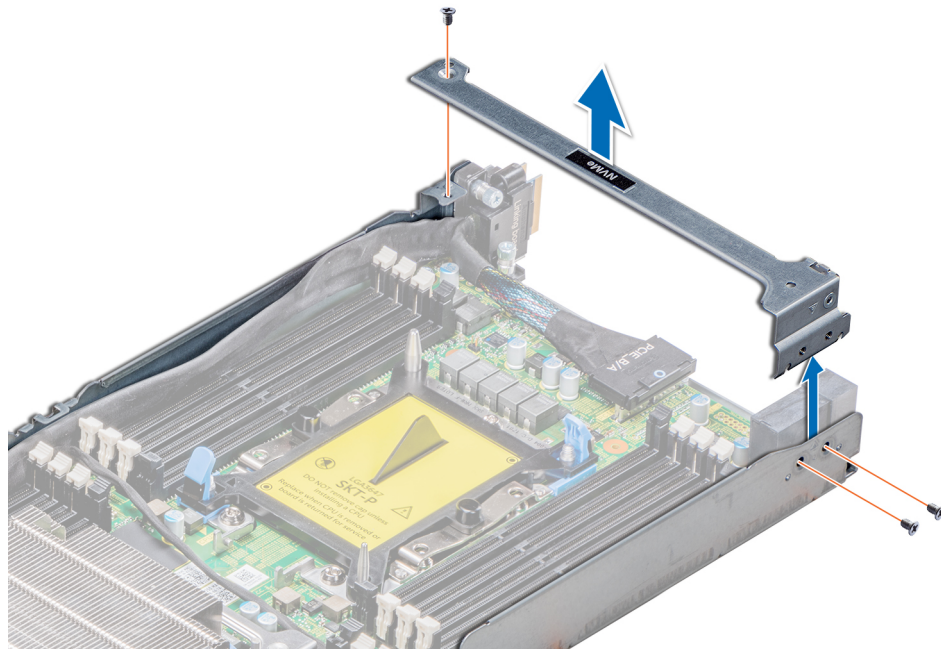

Figure 18. Removing the support bracket

Next step

[Install the support bracket](#).

Installing the support bracket

Prerequisite

- 1 Follow the safety guidelines listed in [Safety instructions](#).

Steps

- 1 Place the support bracket in the sled.
- 2 Using a Phillips #1 screwdriver, replace the screws to secure the bracket in place.

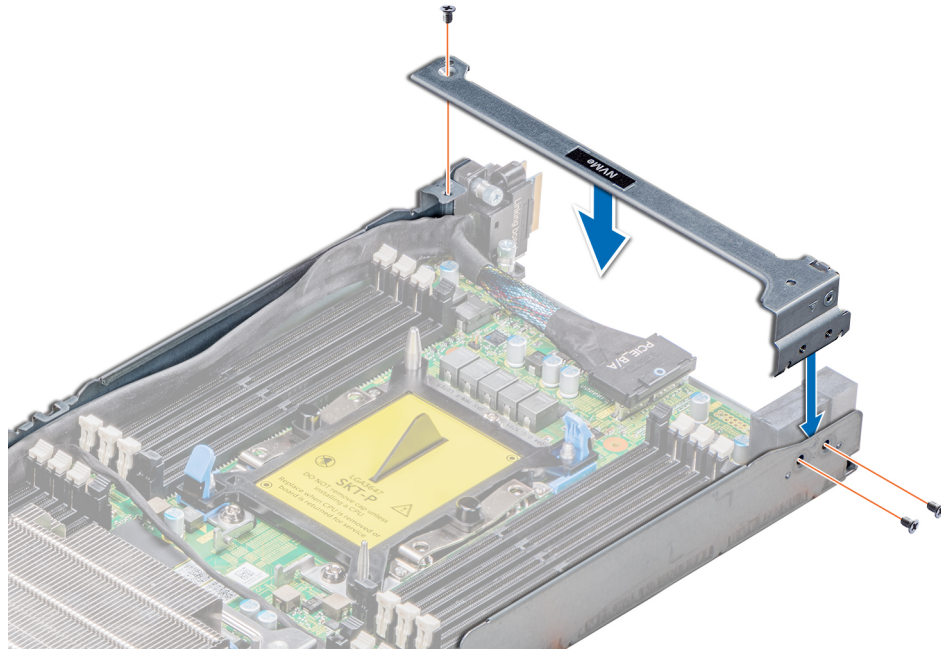

Figure 19. Installing the support bracket

Next steps

- 1 [Install the sled](#) into the enclosure.
- 2 Follow the procedure listed in [After working inside your system](#).

Expansion cards

The expansion card in the system is a printed circuit board that can be inserted into an expansion slot on the system board riser card to add functionality to the system through the expansion bus.

NOTE: A missing or an unsupported expansion card riser logs an System Event Log (SEL) event. This does not prevent your system from powering on and no BIOS, POST messages or F1 or F2 pause is displayed.

PCIe slot priority

Table 26. Supported expansion options

| Riser | Form factor | Slot | CPU mapping | Slot width | Maximum power consumption |
|--|-------------|------|--------------------------------|-------------------------------------|---------------------------|
| PCIe Slot (slot 4) | Low profile | 1 | CPU1 Skylake or Skylake-Fabric | PCIe Gen3 x16 (x16 connector) | 75 W |
| Mezzanine slot (slot 1) | Mezzanine | 1 | CPU1 Skylake or Skylake-Fabric | PCIe Gen3 x8 (through Bridge Board) | 25 W |
| Open Computing Project (OCP) mezzanine slot (slot 3) | Mezzanine | 1 | CPU1 Skylake or Skylake-Fabric | PCIe Gen3 x16 | 25 W |

| Riser | Form factor | Slot | CPU mapping | Slot width | Maximum power consumption |
|-----------------------------------|-------------|------|--------------------------------|---|---------------------------|
| or OCP mezzanine slot (slot 3) | Mezzanine | 1 | CPU1 Skylake-Fabric | OCP MEZZ will be occupied by SKL-F QSFP carrier card | 25 W |
| Riser slot (SATA M.2) (slot 5) | Low profile | 1 | CPU2 Skylake or Skylake-Fabric | PCIe connector data lanes not used for M.2 SATA Riser | 25 W |

NOTE: For the expansion bus specification see the [Expansion bus specifications](#).

Table 27. Supported expansion cards

| Location | Card type | Form factor | Link width | Slot priority | Maximum number of cards |
|--------------------|--|-------------|------------|---------------|-------------------------|
| Mezzanine (slot 1) | Dell HBA H330 mini Adapter | Mezzanine | x8 | 1 | 1 |
| Slot 5 | SATA M.2 | Low profile | x16 | 4 | 1 |
| Slot 4 | Intel Ethernet 10G Dual Port X550-t Adapter | Low profile | x4 | 4 | 1 |
| Slot 4 | Intel Ethernet X710 Dual port 10GbE SFP + Adapter | Low profile | x8 | 4 | 1 |
| Slot 4 | Mellanox ConnectX-4 Lx Dual Port 25 GbE DA/SFP Adapter | Low profile | x8 | 4 | 1 |
| Slot 4 | Intel Gigabit Dual Port I350-t Adapter, 1GB | Low profile | x4 | 4 | 1 |

Removing the expansion card riser assembly

Prerequisites

NOTE: You must install an expansion card filler bracket over an empty expansion slot to maintain Federal Communications Commission (FCC) certification of the system. The brackets also keep dust and dirt out of the system and aid in proper cooling and airflow inside the system.

- 1 Follow the safety guidelines listed in [Safety instructions](#).
- 2 Follow the procedure listed in [Before working inside your system](#).
- 3 [Remove the sled](#) from the enclosure.

Steps

- 1 Remove the screws that secure the expansion card riser assembly.
- 2 Lift the expansion card riser assembly out of the sled.

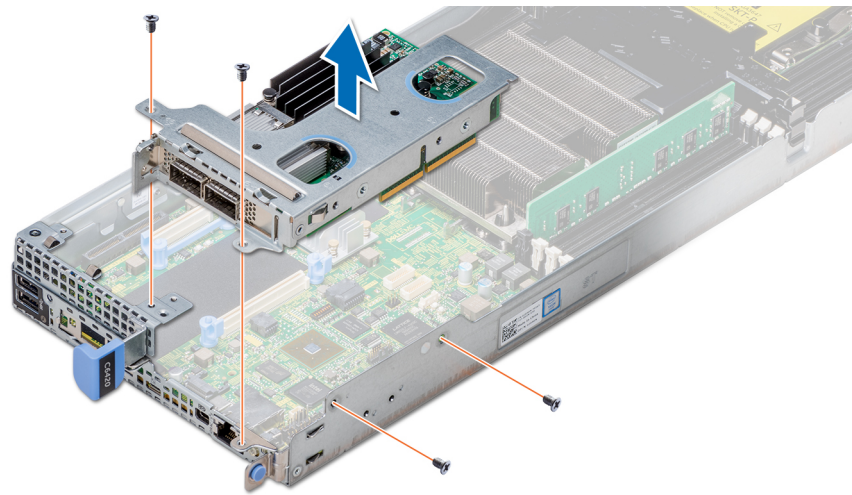

Figure 20. Removing the expansion card riser assembly

Next step

Install the expansion card riser assembly.

Installing the expansion card riser assembly

Prerequisite

NOTE: You must install an expansion card filler bracket over an empty expansion slot to maintain Federal Communications Commission (FCC) certification of the system. The brackets also keep dust and dirt out of the system and aid in proper cooling and airflow inside the system.

Follow the safety guidelines listed in [Safety instructions](#).

Steps

- 1 Place the expansion card assembly into the system board assembly.
- 2 Align the riser card connector with the connector on the system board, and press the expansion card riser assembly into place.
- 3 Using the Phillips #2 screwdriver, tighten the screws that secure the expansion card riser assembly.

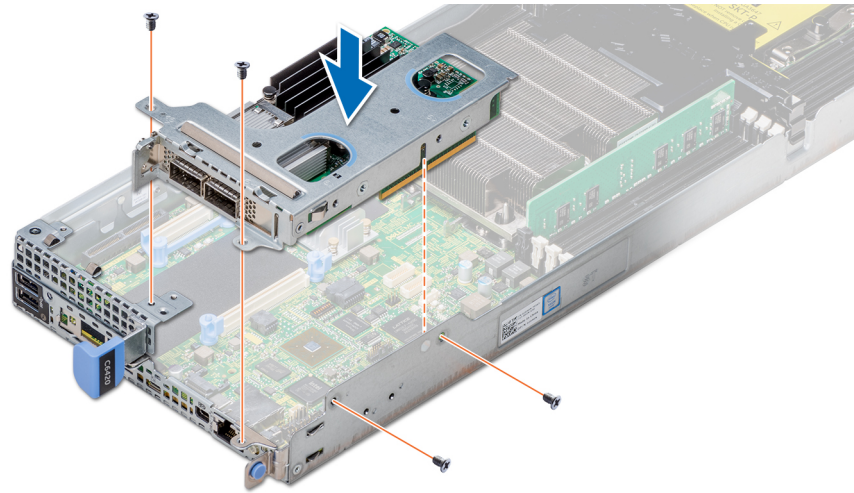

Figure 21. Installing the expansion card riser assembly

Next steps

- 1 [Install the sled](#) into the enclosure.
- 2 Follow the procedure listed in [After working inside your system](#).

Removing an expansion card

Prerequisites

- 1 Follow the safety guidelines listed in [Safety instructions](#).
- 2 Follow the procedure listed in [Before working inside your system](#).
- 3 [Remove the sled](#) from the enclosure.
- 4 [Remove the expansion card riser assembly](#).

Steps

- 1 Remove the screw that secures the expansion card to the assembly.
- 2 Hold the expansion card by its edges, and carefully remove it from the riser card.

NOTE: You must install an expansion card filler bracket over an empty expansion slot to maintain Federal Communications Commission (FCC) certification of the system. The brackets also keep dust and dirt out of the system and aid in proper cooling and airflow inside the system.

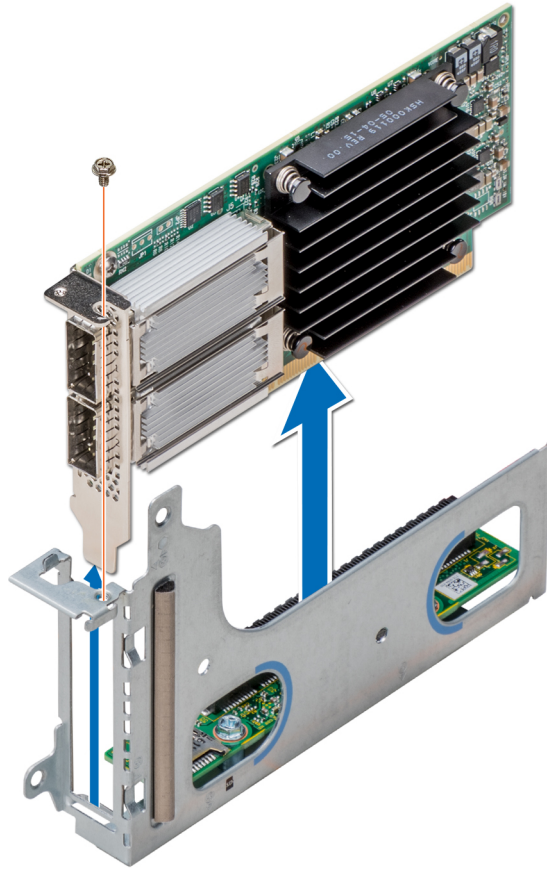

Figure 22. Removing an expansion card

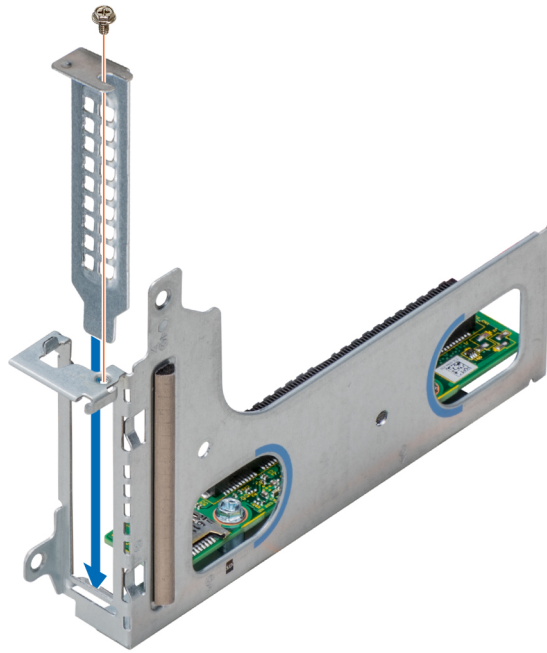

Figure 23. Installing the expansion card filler bracket

Next step

Install the [expansion card](#) or the expansion card filler bracket.

Installing an expansion card

Prerequisites

CAUTION: Expansion cards can only be installed in the slots on the expansion card riser. Do not attempt to install expansion cards directly into the riser connector on the system board.

- 1 Follow the safety guidelines listed in [Safety instructions](#).
- 2 Unpack the expansion card and prepare it for installation. For instructions, see the documentation accompanying the card.

Steps

- 1 If installed, remove the filler bracket by performing the following steps:

- a Remove the screw that secures the filler bracket.
- b Hold the filler bracket by its edges, and carefully remove it from the riser card.

NOTE: You must install an expansion card filler bracket over an empty expansion slot to maintain Federal Communications Commission (FCC) certification of the system. The brackets also keep dust and dirt out of the system and aid in proper cooling and airflow inside the system.

- 2 Holding the card by its edges, position the card so that the card edge connector aligns with the connector on the riser card.
- 3 Insert the card edge connector and push the card firmly into the riser card until the card is fully seated.
- 4 Replace the screw that secures the expansion card.

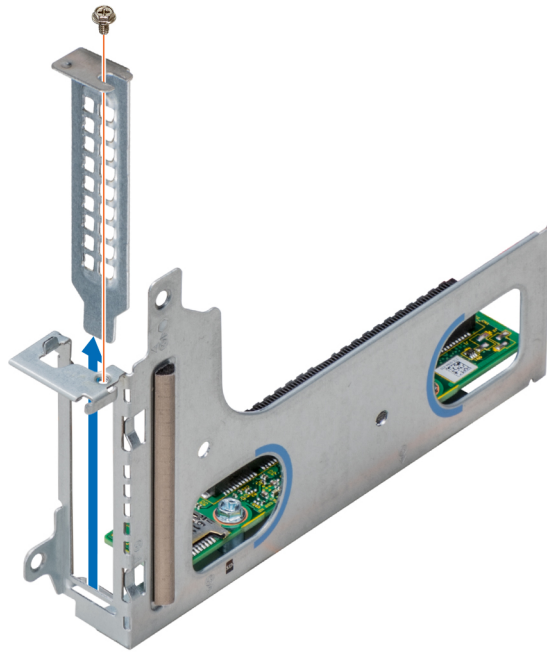

Figure 24. Removing the expansion card filler bracket

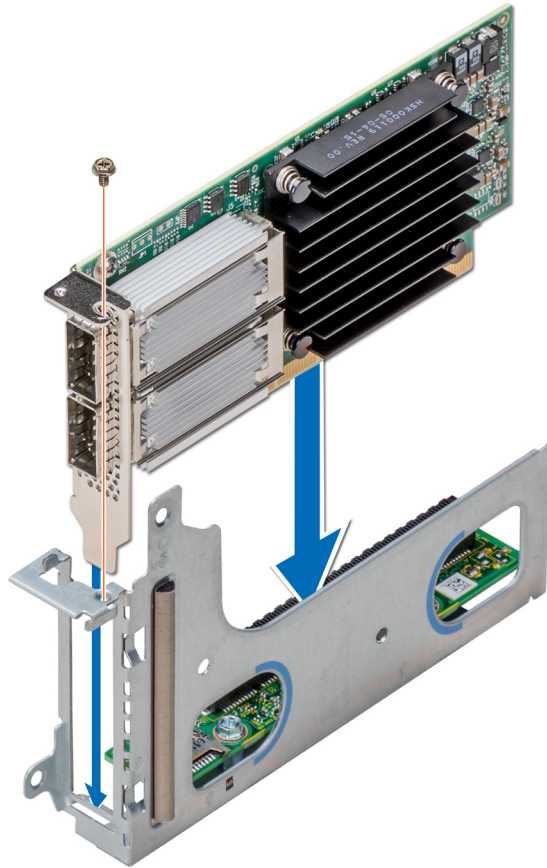

Figure 25. Installing an expansion card

Next steps

- 1 [Install the expansion card riser assembly.](#)
- 2 [Install the sled](#) into the enclosure.
- 3 Follow the procedure listed in [After working inside your system.](#)

Removing the riser card

Prerequisites

- 1 Follow the safety guidelines listed in [Safety instructions.](#)
- 2 Follow the procedure listed in [Before working inside your system.](#)
- 3 [Remove the sled](#) from the enclosure.
- 4 [Remove the expansion card riser assembly.](#)
- 5 If installed, [remove the expansion card.](#)

Steps

- 1 Using the Phillips #2 screwdriver, remove the screws that secure the riser card to the expansion card bracket.
- 2 Lift the riser card away from the expansion card bracket.

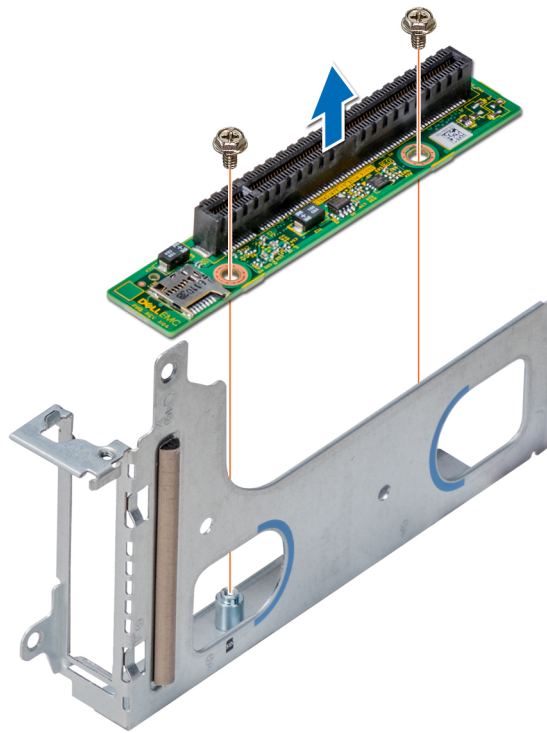

Figure 26. Removing the riser card

Next step

Install the riser card.

Installing the riser card

Prerequisite

- 1 Follow the safety guidelines listed in [Safety instructions](#).

Steps

- 1 Place the riser card into the expansion card bracket.
- 2 Using the Phillips #2 screwdriver, tighten the screws that secure the riser card to the expansion card bracket.

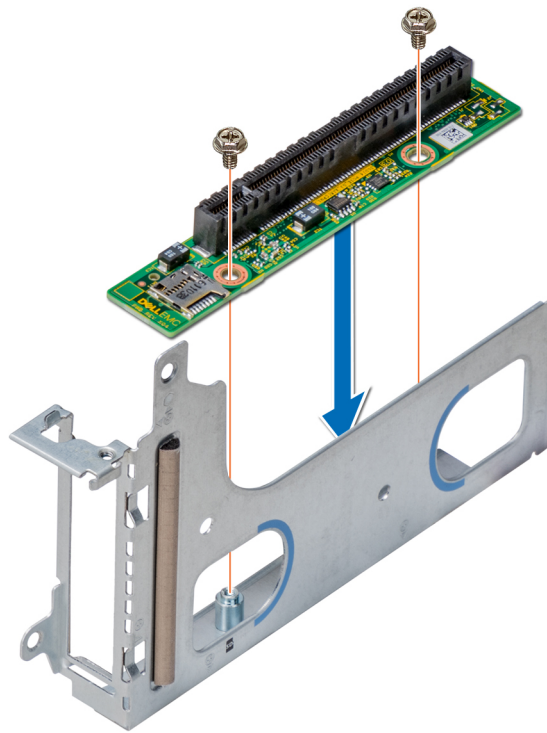

Figure 27. Installing the riser card

Next steps

- 1 If removed, [install the expansion card](#).
- 2 [Install the expansion card riser assembly](#).
- 3 [Install the sled](#) into the enclosure.
- 4 Follow the procedure listed in [After working inside your system](#).

M.2 SATA drive

The BOSS card is a simple RAID solution card designed specifically for booting a server's operating system. The card supports up to two 6 Gbps M.2 SATA drives. The BOSS adapter card has a x8 connector using PCIe gen 2.0 x2 lanes, available only in the low-profile and half-height form factor.

Removing the M.2 SATA x16 riser

Prerequisites

- 1 Follow the safety guidelines listed in [Safety instructions](#).
- 2 Follow the procedure listed in [Before working inside your system](#).
- 3 [Remove the sled](#) from the enclosure.

Steps

- 1 Using the Phillips #1 screwdriver, loosen the screw that secures the riser to the sled.
- 2 Lift the riser up to disengage the riser from the connector on the system board.
- 3 Disconnect the data cable from the riser.

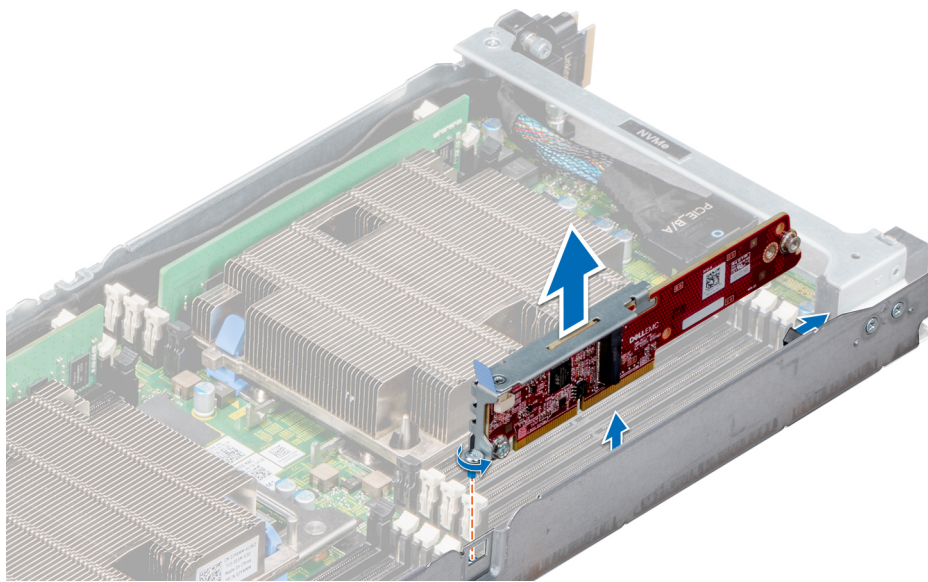

Figure 28. Removing the M.2 SATA x16 riser

Next step

Install the M.2 SATA x16 riser.

Installing the M.2 SATA x16 riser

Prerequisite

- 1 Follow the safety guidelines listed in [Safety instructions](#).

Steps

- 1 Connect the data cable to the riser.
- 2 Insert the keyed end of the M.2 SATA riser into the lock on the system board.
- 3 Align and insert the edge connector into the connector on the system board.
- 4 Using the Phillips #2 screwdriver, tighten the screw to secure the riser to the sled.

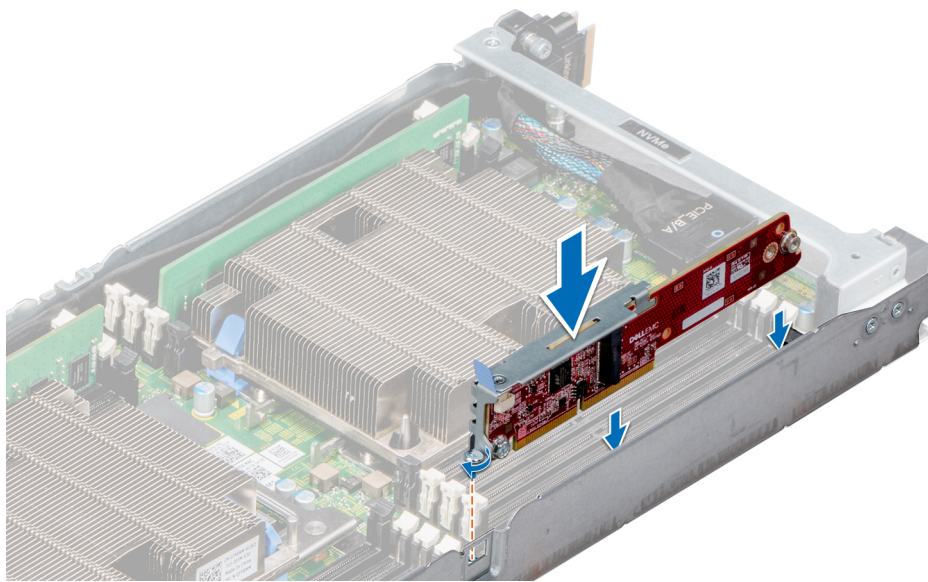

Figure 29. Installing the M.2 SATA x16 riser

Next steps

- 1 [Install the sled](#) into the enclosure.
- 2 Follow the procedure listed in [After working inside your system](#).

Removing the M.2 SATA card

Prerequisites

- 1 Follow the safety guidelines listed in [Safety instructions](#).
- 2 Follow the procedure listed in [Before working inside your system](#).
- 3 [Remove the sled](#) from the enclosure.
- 4 If applicable, [remove the expansion card riser assembly](#).
- 5 [Remove the M.2 x16 riser](#).

Steps

- 1 Using the Phillips #1 screwdriver, unscrew the screw that secures the M.2 card to the board.
- 2 Pull the card out of the connector and lift the card away.

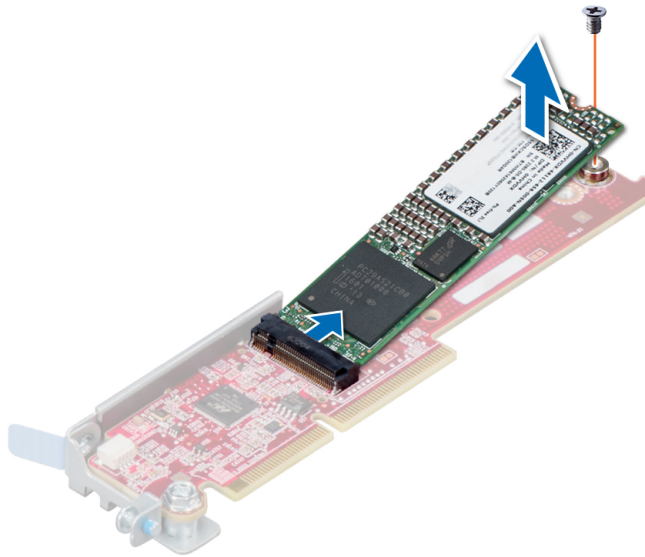

Figure 30. Removing the M.2 SATA card from the M.2 SATA x16 riser

Next step

Install the M.2 SATA card.

Installing the M.2 SATA card

Prerequisite

- 1 Follow the safety guidelines listed in [Safety instructions](#).

Steps

- 1 Insert the edge connector of the M.2 SATA card into the connector on the board, and push the card in.
- 2 Using the Phillips #1 screwdriver, secure the card in place.

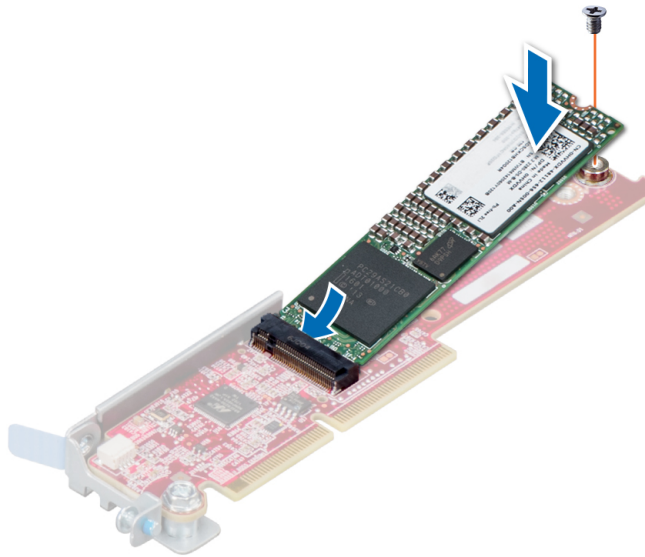

Figure 31. Installing the M.2 SATA card on the SATA x16 riser

Next steps

- 1 If removed, [install the expansion card riser assembly](#).
- 2 [Install the M.2 x16 riser](#).
- 3 [Install the sled](#) into the enclosure.
- 4 Follow the procedure listed in [After working inside your system](#).

Mezzanine and OCP cards

The mezzanine and Open Compute Project (OCP) cards connect to the PCI bus. They are physically smaller than the standard expansion card, and often connect to a dedicated connector on the system board.

Removing a mezzanine card

Prerequisites

NOTE: The procedure to remove the mezzanine blank is similar to the removal of a mezzanine card.

- 1 Follow the safety guidelines listed in [Safety instructions](#).
- 2 Follow the procedure listed in [Before working inside your system](#).
- 3 [Remove the sled](#) from the enclosure.
- 4 [Remove the expansion card riser assembly](#).

Steps

- 1 Remove the screws that secure the mezzanine card to the sled.
- 2 Lift the mezzanine card out of the sled.

NOTE: You must install an expansion card filler bracket over an empty expansion slot to maintain Federal Communications Commission (FCC) certification of the system. The brackets also keep dust and dirt out of the system and aid in proper cooling and airflow inside the system.

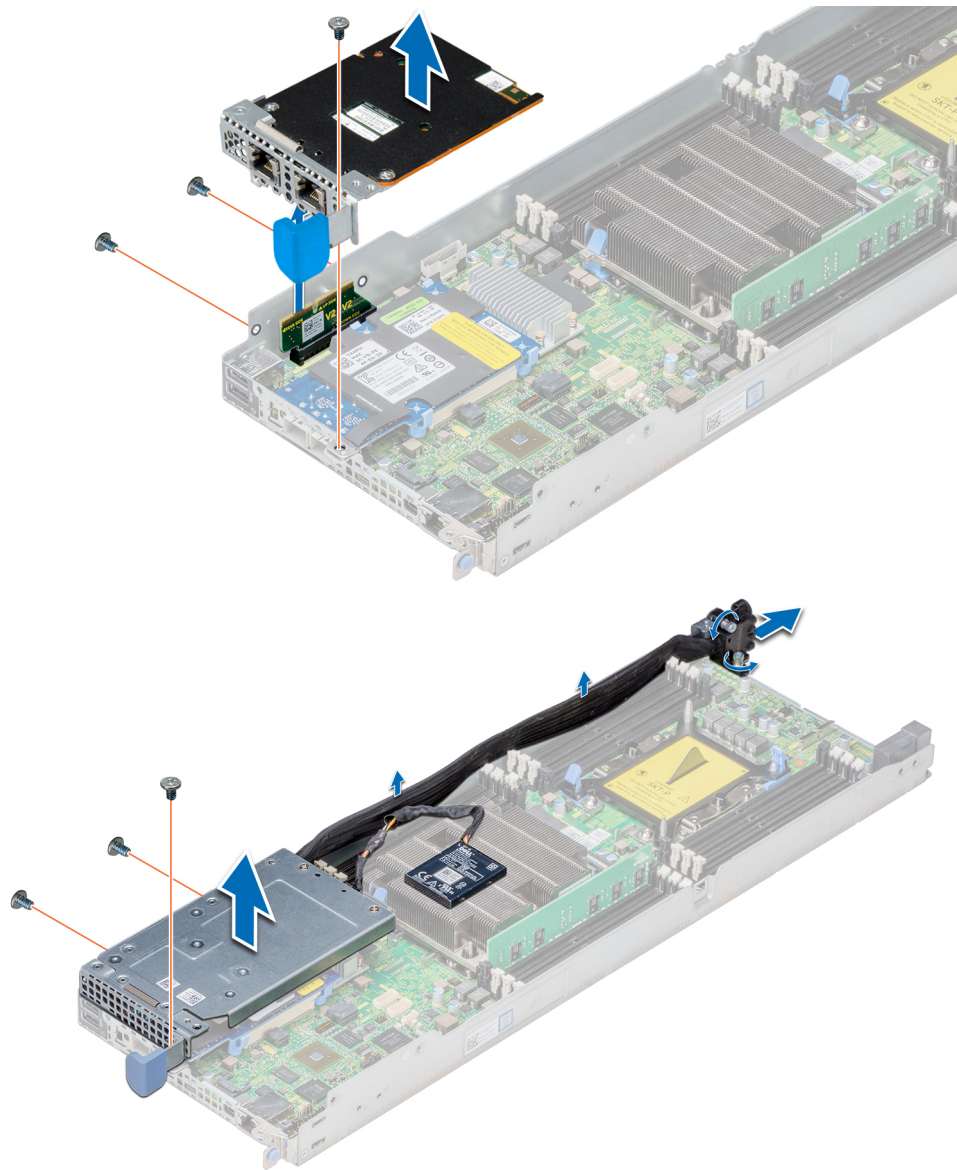

Figure 32. Removing a mezzanine card

Next step

Install the [mezzanine card](#) or the mezzanine card filler bracket.

Installing a mezzanine card

Prerequisite

NOTE: The procedure to install the mezzanine blank is similar to the removal of a mezzanine card.

- 1 Follow the safety guidelines listed in [Safety instructions](#).

Steps

- 1 Attach and secure the mezzanine card bracket to the mezzanine card.
- 2 Holding the card by its edges, position the card so that the card edge connector aligns with the connector of the bridge board on the system board.

- 3 Insert the card edge connector and push the card firmly until the card is fully seated on the bridge board.
- 4 Using the Phillips #2 screwdriver, secure the mezzanine card and bracket assembly to the sled using screws.

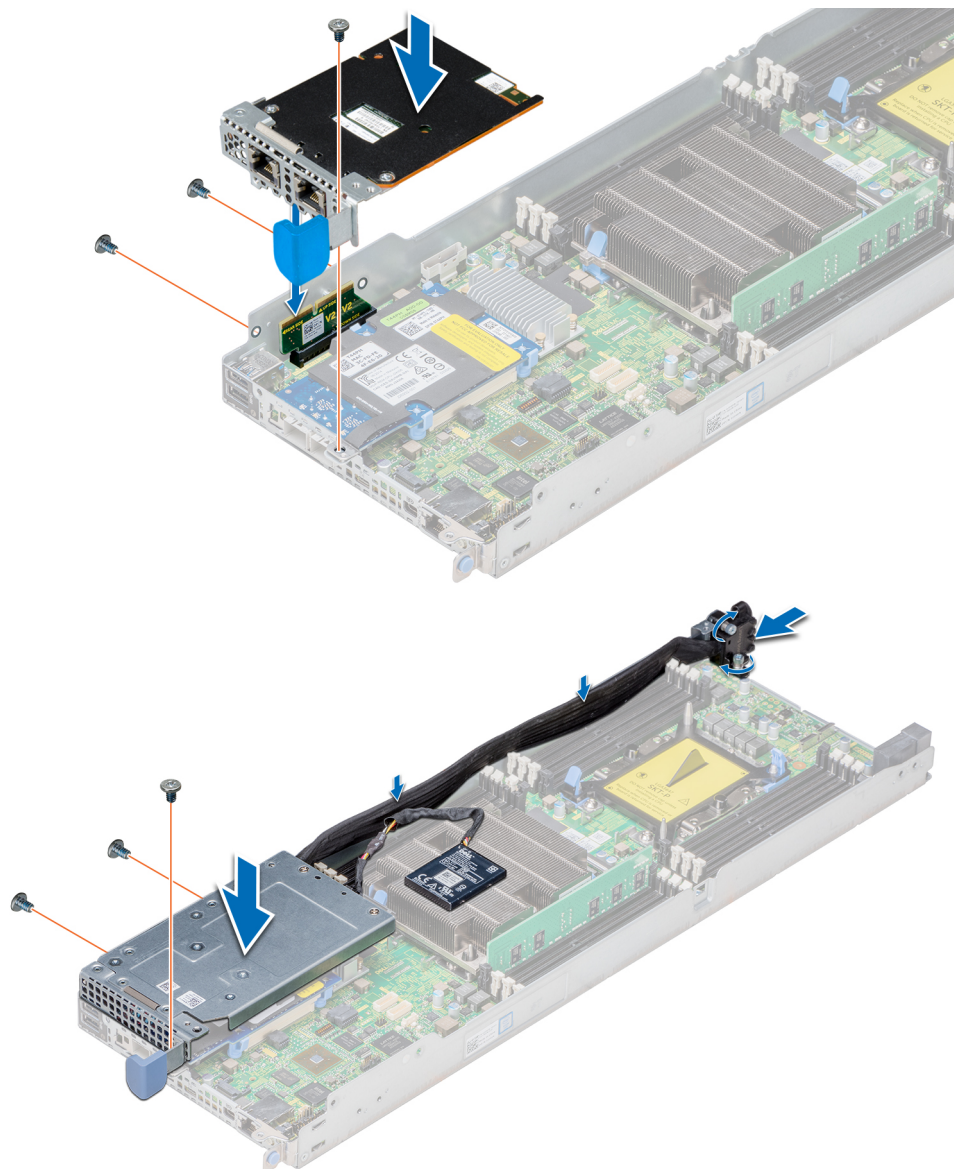

Figure 33. Installing a mezzanine card

Next steps

- 1 [Install the mezzanine card](#) or the mezzanine card filler bracket.
- 2 [Install the expansion card riser assembly](#).
- 3 [Install the sled](#) into the enclosure.
- 4 Follow the procedure listed in [After working inside your system](#).

Removing the mezzanine card bridge board

Prerequisites

- 1 Follow the safety guidelines listed in [Safety instructions](#).
- 2 Follow the procedure listed in [Before working inside your system](#).
- 3 [Remove the sled](#) from the enclosure.
- 4 [Remove the expansion card riser assembly](#).
- 5 [Remove the mezzanine card](#).

Step

Pull the mezzanine card bridge board away from the mezzanine card slot on the system board.

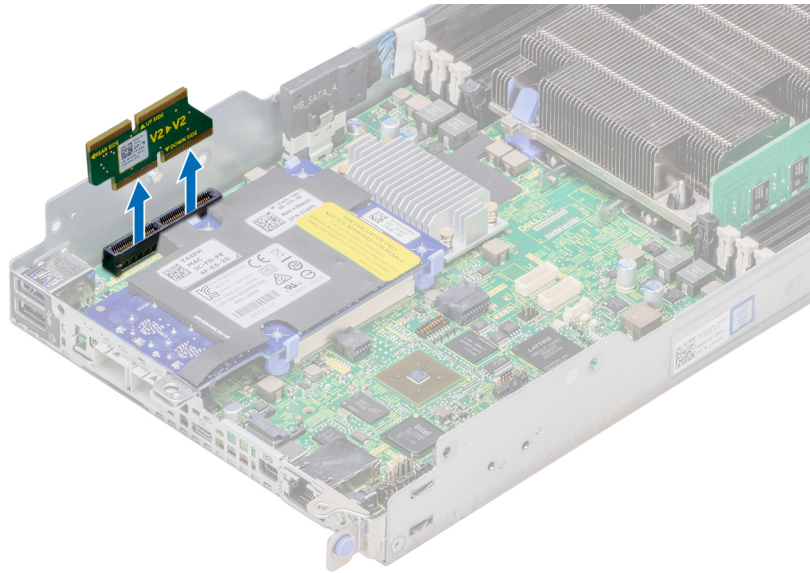

Figure 34. Removing the mezzanine card bridge board

Next step

[Install the mezzanine card bridge board](#).

Installing the mezzanine card bridge board

Prerequisite

- 1 Follow the safety guidelines listed in [Safety instructions](#).

Step

Insert the mezzanine card bridge board into the mezzanine slot on the system board.

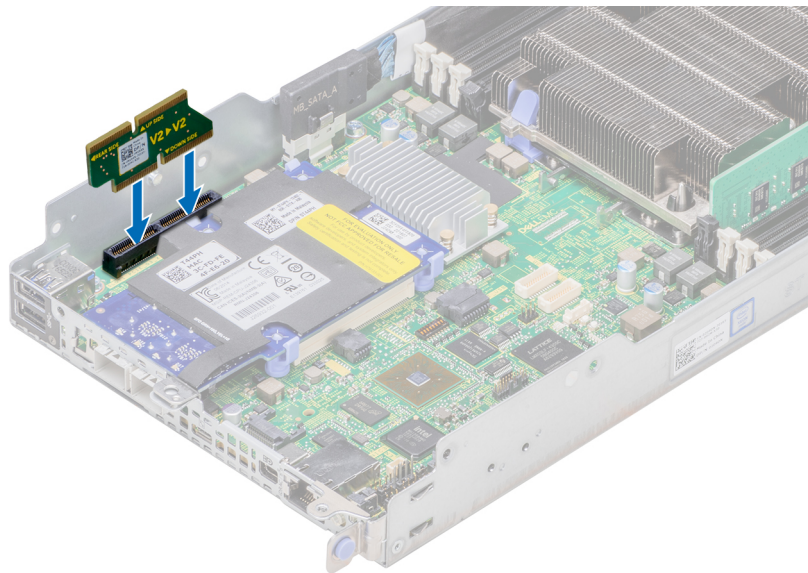

Figure 35. Installing the mezzanine card bridge board

Next steps

- 1 [Install the mezzanine card.](#)
- 2 [Install the expansion card riser assembly.](#)
- 3 [Install the sled](#) into the enclosure.
- 4 Follow the procedure listed in [After working inside your system.](#)

Removing the OCP card

Prerequisites

NOTE: The procedure to remove the mezzanine blank is similar to the removal of a mezzanine card.

- 1 Follow the safety guidelines listed in [Safety instructions.](#)
- 2 Follow the procedure listed in [Before working inside your system.](#)
- 3 [Remove the sled](#) from the enclosure.
- 4 [Remove the mezzanine card.](#)

Steps

- 1 Push the blue retention clips away on one side and release the Open Compute Project (OCP) card. Repeat step 1 to release the card from the clips on the other side.
- 2 Slide the card toward the front of the sled to disengage the connectors from the chassis and lift the card up.

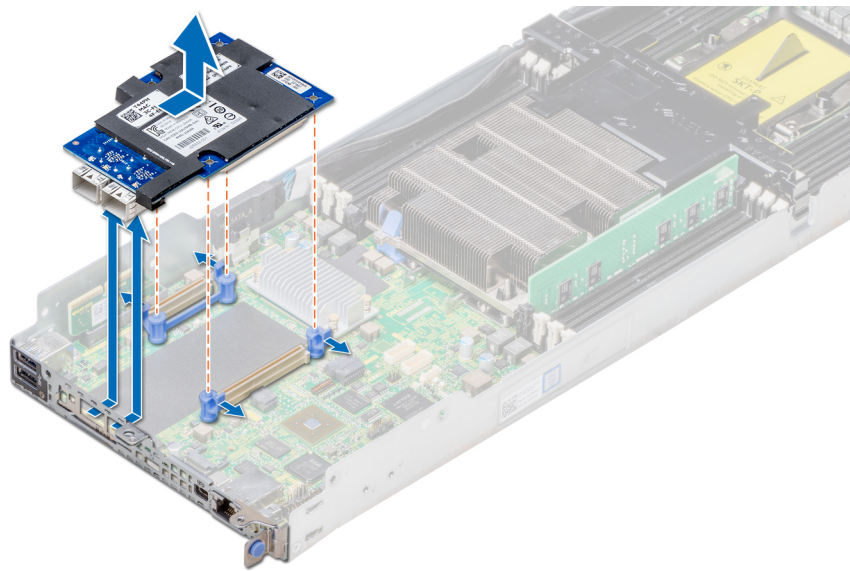

Figure 36. Removing the OCP card

Next step

Install the OCP card.

Installing the OCP card

Prerequisite

Follow the safety guidelines listed in [Safety instructions](#).

Steps

- 1 Insert the Open Compute Project (OCP) card into the sled, aligning the connector on the card with the connector in the system board.
- 2 You must also align the holes on the card with the guide pins on the blue retention clips.
- 3 Push down to lock the card in place.

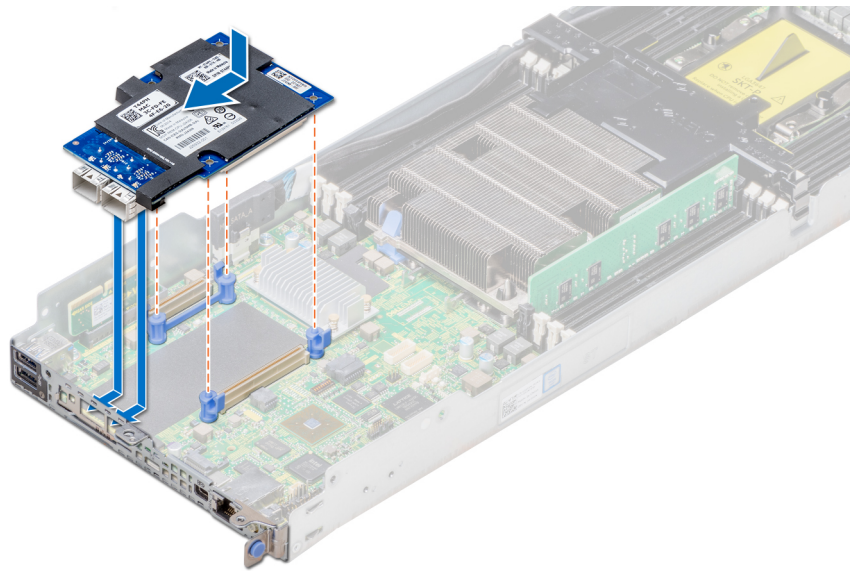

Figure 37. Installing the OCP card

Next steps

- 1 [Install the mezzanine card.](#)
- 2 [Install the sled](#) into the enclosure.
- 3 Follow the procedure listed in [After working inside your system.](#)

System battery

The system battery is used to power the real-time clock of the system.

NOTE: There is a system battery in each of the sleds.

Replacing system battery

Prerequisites

WARNING: There is a danger of a new battery exploding if it is incorrectly installed. Replace the battery only with the same or equivalent type recommended by the manufacturer. For more information, see the safety information that shipped with your system.

NOTE: Battery is a Field Replaceable Unit (FRU). Only Dell EMC certified service technicians must remove or install the system battery.

- 1 Follow the safety guidelines listed in [Safety instructions.](#)
- 2 Follow the procedure listed in [Before working inside your system.](#)
- 3 [Remove the sled](#) from the enclosure.
- 4 [Remove the expansion card riser assembly.](#)

Steps

- 1 Locate the battery socket. For more information, see [System board connectors.](#)
- 2 Insert a plastic scribe at the negative side of the battery connector and lever the battery up, lift the battery out of the socket.

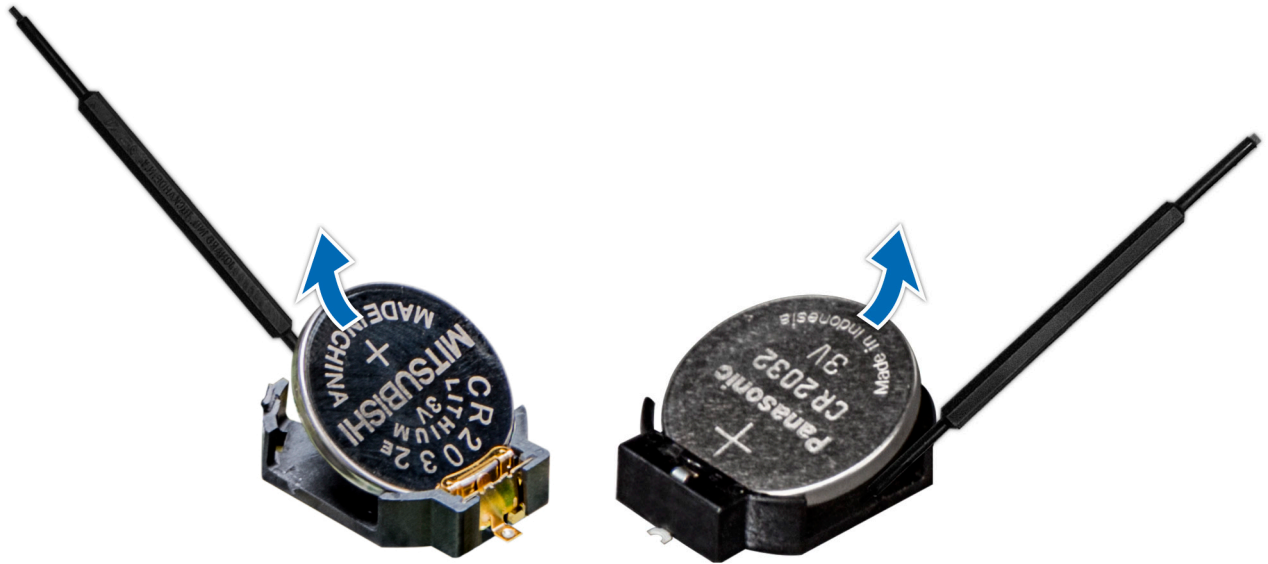

Figure 38. Removing system battery

Next step

Install the system battery.

Installing the system battery

Prerequisites

⚠ WARNING: There is a danger of a new battery exploding if it is incorrectly installed. Replace the battery only with the same or equivalent type recommended by the manufacturer. For more information, see the safety information that shipped with your system.

📘 NOTE: Battery is a Field Replaceable Unit (FRU). Removal and installation procedures are to be performed only by Dell certified service technicians.

- 1 Follow the safety guidelines listed in [Safety instructions](#).
- 2 Follow the procedure listed in [Before working inside your system](#).

Steps

- 1 Locate the battery socket. For more information, see [System board connectors](#).
- 2 Hold the battery with the "+" facing up and slide it under the securing tabs.
- 3 Press the battery into the connector until it snaps into place.

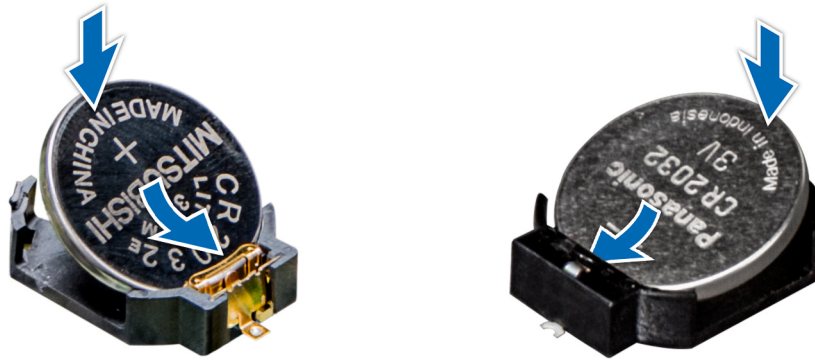

Figure 39. Installing the system battery

Next steps

- 1 If removed, [install the expansion card riser](#).
- 2 [Install the sled](#) into the enclosure.
- 3 Follow the procedure listed in [After working inside your system](#).
- 4 While booting, press F2 to enter System Setup and ensure that the battery is operating properly.
- 5 Enter the correct time and date in the System Setup **Time** and **Date** fields.
- 6 Exit System Setup.

Trusted Platform Module

Trusted Platform Module (TPM) is a dedicated microprocessor designed to secure hardware by integrating cryptographic keys into devices. Software can use a TPM to authenticate hardware devices. Because each TPM chip has a unique and secret RSA key which is embedded during the manufacture of the TPM, it is capable of performing platform authentication operation.

Replacing the Trusted Platform Module

Prerequisites

① **NOTE:** There is a TPM slot on the system board of each sled.

- 1 Follow the safety guidelines listed in [Safety instructions](#).
- 2 Follow the procedure listed in [Before working inside your system](#).

① **NOTE:**

- Ensure that your operating system supports the version of the TPM module being installed.
- Ensure that you download and install the latest BIOS firmware on your system.
- Ensure that the BIOS is configured to enable UEFI boot mode.

About this task

⚠ **CAUTION:** If you are using the Trusted Platform Module (TPM) with an encryption key, you may be prompted to create a recovery key during program or System Setup. Work with the customer to create and safely store this recovery key. When replacing this system board, you must supply the recovery key when you restart your system or program before you can access the encrypted data on your hard drives.

CAUTION: Once the TPM plug-in module is installed, it is cryptographically bound to that specific system board. Any attempt to remove an installed TPM plug-in module breaks the cryptographic binding, the removed TPM cannot be reinstalled or installed on another system board.

Removing the TPM

- 1 Locate the TPM connector on the system board.
- 2 Press to hold the module down and remove the screw using the security Torx 8-bit shipped with the TPM module.
- 3 Slide the TPM module out from its connector.
- 4 Push the plastic rivet away from the TPM connector and rotate it 90° counterclockwise to release it from the system board.
- 5 Pull the plastic rivet out of its slot on the system board.

Installing the TPM

Steps

- 1 To install the TPM, align the edge connectors on the TPM with the slot on the TPM connector.
- 2 Insert the TPM into the TPM connector such that the plastic rivet aligns with the slot on the system board.
- 3 Press the plastic rivet until the rivet snaps into place.

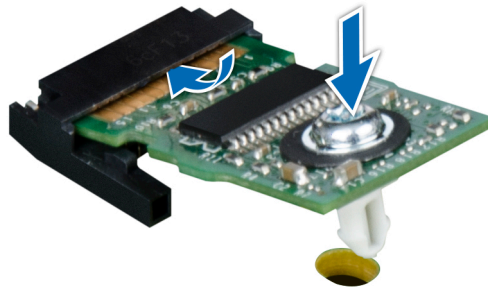

Figure 40. Installing the TPM

- 4 Replace the screw that secures the TPM to the system board.

Next step

- 1 Follow the procedure listed in [After working inside your system](#).

Initializing the TPM 1.2 for TXT users

- 1 While booting your system, press F2 to enter System Setup.
- 2 On the **System Setup Main Menu** screen, click **System BIOS > System Security Settings**.
- 3 From the **TPM Security** option, select **On with Pre-boot Measurements**.
- 4 From the **TPM Command** option, select **Activate**.
- 5 Save the settings.
- 6 Restart your system.
- 7 Enter **System Setup** again.
- 8 On the **System Setup Main Menu** screen, click **System BIOS > System Security Settings**.
- 9 From the **Intel TXT** option, select **On**.

Initializing the TPM 2.0 for TXT users

- 1 While booting your system, press F2 to enter System Setup.
- 2 On the **System Setup Main Menu** screen, click **System BIOS > System Security Settings**.
- 3 From the **TPM Security** option, select **On**.
- 4 Save the settings.
- 5 Restart your system.
- 6 Enter **System Setup** again.
- 7 On the **System Setup Main Menu** screen, click **System BIOS > System Security Settings**.
- 8 Select the **TPM Advanced Settings** option.
- 9 From the **TPM2 Algorithm Selection** option, select **SHA256**, then go back to **System Security Settings** screen.
- 10 On the **System Security Settings** screen, from the **Intel TXT** option, select **On**.
- 11 Save the settings.
- 12 Restart your system.

Using system diagnostics

If you experience a problem with your system, run the system diagnostics before contacting Dell for technical assistance. The purpose of running system diagnostics is to test your system hardware without using additional equipment or risking data loss. If you are unable to fix the problem yourself, service and support personnel can use the diagnostics results to help you solve the problem.

Dell Embedded System Diagnostics

NOTE: The Dell Embedded System Diagnostics is also known as Enhanced Pre-boot System Assessment (ePSA) diagnostics.

The Embedded System Diagnostics provides a set of options for particular device groups or devices allowing you to:

- Run tests automatically or in an interactive mode
- Repeat tests
- Display or save test results
- Run thorough tests to introduce additional test options to provide extra information about the failed device(s)
- View status messages that inform you if tests are completed successfully
- View error messages that inform you of problems encountered during testing

Running the Embedded System Diagnostics from Boot Manager

Run the Embedded System Diagnostics (ePSA) if your system does not boot.

- 1 When the system is booting, press F11.
- 2 Use the up arrow and down arrow keys to select **System Utilities > Launch Diagnostics**.
- 3 Alternatively, when the system is booting, press F10, select **Hardware Diagnostics > Run Hardware Diagnostics**.
The **ePSA Pre-boot System Assessment** window is displayed, listing all devices detected in the system. The diagnostics starts executing the tests on all the detected devices.

Running the Embedded System Diagnostics from the Dell Lifecycle Controller

- 1 As the system boots, press F10.
- 2 Select **Hardware Diagnostics → Run Hardware Diagnostics**.
The **ePSA Pre-boot System Assessment** window is displayed, listing all devices detected in the system. The diagnostics starts executing the tests on all the detected devices.

System diagnostic controls

| Menu | Description |
|----------------------|---|
| Configuration | Displays the configuration and status information of all detected devices. |
| Results | Displays the results of all tests that are run. |
| System health | Provides the current overview of the system performance. |
| Event log | Displays a time-stamped log of the results of all tests run on the system. This is displayed if at least one event description is recorded. |

Jumpers and connectors

This topic provides specific information about the jumpers. It also provides some basic information about jumpers and switches and describes the connectors on the various boards in the system. Jumpers on the system board help to disable the system and setup passwords. You must know the connectors on the system board to install components and cables correctly.





Topics:

- [System board jumper settings](#)
- [System board connectors](#)
- [Disabling forgotten password](#)

System board jumper settings

For information on resetting the password jumper to disable a password, see [Disabling forgotten password](#).

Table 28. System board jumper settings

| Jumper | Setting | Description |
|-----------|--|--|
| NVRAM_CLR |  2 4 6 (default) | The BIOS configuration settings are retained at system boot. |
| |  2 4 6 | The BIOS configuration settings are cleared at system boot. |
| PWRD_EN |  1 3 5 (default) | The BIOS password feature is enabled. |
| |  1 3 5 | The BIOS password feature is disabled. iDRAC local access is unlocked at next AC power cycle. iDRAC password reset is enabled in F2 iDRAC settings menu. |

System board connectors

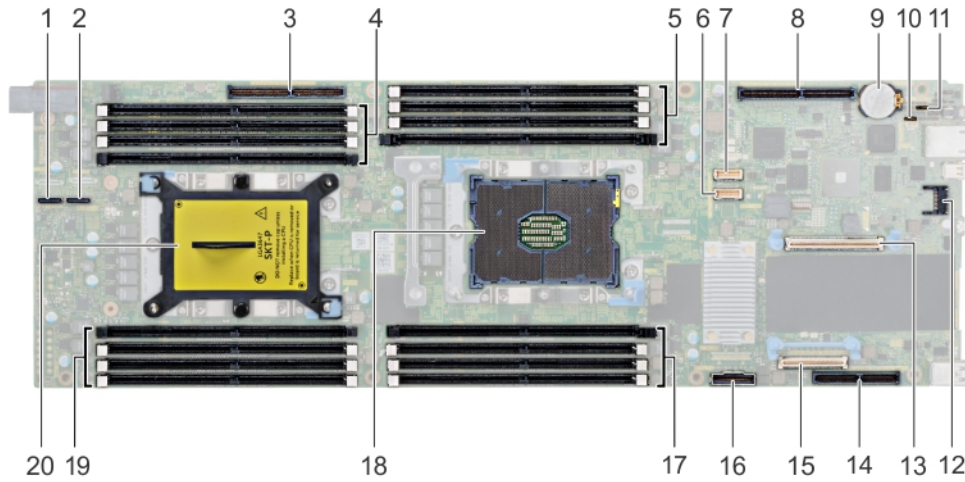

Figure 41. XC6420 system board connectors

Table 29. System Board Connectors and Description

| Item | Connector | Description |
|------|------------------|------------------------------------|
| 1 | PCIe B | NVMe B connector |
| 2 | PCIe A | NVMe A connector |
| 3 | PCIe Slot 5 | Slot 5: x16 PCIe Gen3 from CPU 2 |
| 4 | DIMM sockets (4) | DIMM B8, DIMM B4, DIMM B5, DIMM B6 |
| 5 | DIMM sockets (4) | DIMM A8, DIMM A4, DIMM A5, DIMM A6 |
| 6 | HFI_SB_1 | Side band cable 1 for OCP |
| 7 | HFI_SB_2 | Side band cable 2 for OCP |
| 8 | PCIe Slot 4 | Slot 4: x16 PCIe Gen3 CPU 1 |
| 9 | Batt | System battery |
| 10 | PWDCLR | Password clear jumper |
| 11 | NVRAMCLR | NVRAM clear jumper |
| 12 | PCIe Slot 3 | Slot 3: x8 PCIe Gen3 from CPU 1 |
| 13 | TPM | TPM connector |
| 14 | PCIe Slot 1 | Slot 1: x8 PCIe Gen3 from CPU 1 |
| 15 | PCIe Slot 2 | Slot 2: x8 PCIe Gen3 from CPU 1 |
| 16 | SATA_A | SATA cable connector |
| 17 | DIMM sockets (4) | DIMM A7, DIMM A1, DIMM A2, DIMM A3 |
| 18 | CPU 1 | CPU socket 1 |
| 19 | DIMM sockets (4) | DIMM B7, DIMM B1, DIMM B2, DIMM B3 |

| Item | Connector | Description |
|------|-----------|----------------------------------|
| 20 | CPU 2 | CPU socket 2 (with a dust cover) |

Disabling forgotten password

The software security features of the system include a system password and a setup password. The password jumper enables or disables password features and clears any password(s) currently in use.

Prerequisite

⚠ CAUTION: Many repairs may only be done by a certified service technician. You should only perform troubleshooting and simple repairs as authorized in your product documentation, or as directed by the online or telephone service and support team. Damage due to servicing that is not authorized by Dell is not covered by your warranty. Read and follow the safety instructions that are shipped with your product.

Steps

- 1 Turn off the system, including any attached peripherals, and disconnect the system from the electrical outlet.
- 2 Remove the system cover.
- 3 Move the jumper on the system board jumper from pins 2 and 4 to pins 4 and 6.
- 4 Install the system cover.

The existing passwords are not disabled (erased) until the system boots with the jumper on pins 4 and 6. However, before you assign a new system and/or setup password, you must move the jumper back to pins 2 and 4.

ⓘ NOTE: If you assign a new system and/or setup password with the jumper on pins 4 and 6, the system disables the new password(s) the next time it boots.

- 5 Reconnect the system to its electrical outlet and turn on the system, including any attached peripherals.
- 6 Turn off the system, including any attached peripherals, and disconnect the system from the electrical outlet.
- 7 Remove the system cover.
- 8 Move the jumper on the system board jumper from pins 4 and 6 to pins 2 and 4.
- 9 Install the system cover.
- 10 Reconnect the system to its electrical outlet and turn on the system, including any attached peripherals.
- 11 Assign a new system and/or setup password.

Getting help

Topics:

- [Contacting Dell](#)
- [Documentation feedback](#)
- [Accessing system information by using QRL](#)
- [Receiving automated support with SupportAssist](#)

Contacting Dell

Dell EMC provides several online and telephone based support and service options. If you do not have an active internet connection, you can find contact information about your purchase invoice, packing slip, bill, or Dell EMC product catalog. Availability varies by country and product, and some services may not be available in your area. To contact Dell EMC for sales, technical assistance, or customer service issues:

- 1 Go to **Dell.com/support**.
- 2 Select your country from the drop-down menu on the lower right corner of the page.
- 3 For customized support:
 - a Enter your system Service Tag in the **Enter your Service Tag** field.
 - b Click **Submit**.The support page that lists the various support categories is displayed.
- 4 For general support:
 - a Select your product category.
 - b Select your product segment.
 - c Select your product.The support page that lists the various support categories is displayed.
- 5 For contact details of Dell EMC Global Technical Support:
 - a Click **Global Technical Support**.
 - b The **Contact Technical Support** page is displayed with details to call, chat, or e-mail the Dell EMC Global Technical Support team.

Documentation feedback

You can rate the documentation or write your feedback on any of our Dell documentation pages and click **Send Feedback** to send your feedback.

Accessing system information by using QRL

You can use the Quick Resource Locator (QRL) to get immediate access to the information about your system.

Prerequisites

Ensure that your smartphone or tablet has the QR code scanner installed.

The QRL includes the following information about your system:

- How-to videos
- Reference materials, including the Installation and Service Manual, and mechanical overview

- A direct link to Dell to contact technical assistance and sales teams

Steps

- 1 Go to **Dell.com/QRL** and navigate to your specific product or
- 2 Use your smartphone or tablet to scan the model-specific Quick Resource (QR) code on your Dell EMC XC6420 Hyper-converged appliance or in the Quick Resource Locator section.

Quick Resource Locator for XC6420 systems



Figure 42. Quick Resource Locator for XC6420 systems

Receiving automated support with SupportAssist

Dell SupportAssist is an optional Dell Services offering that automates technical support for your Dell server, storage, and networking devices. By installing and setting up a SupportAssist application in your IT environment, you can receive the following benefits:

- **Automated issue detection** — SupportAssist monitors your Dell devices and automatically detects hardware issues, both proactively and predictively.
- **Automated case creation** — When an issue is detected, SupportAssist automatically opens a support case with Dell Technical Support.
- **Automated diagnostic collection** — SupportAssist automatically collects system state information from your devices and uploads it securely to Dell. This information is used by Dell Technical Support to troubleshoot the issue.
- **Proactive contact** — A Dell Technical Support agent contacts you about the support case and helps you resolve the issue.

The available benefits vary depending on the Dell Service entitlement purchased for your device. For more information about SupportAssist, go to **Dell.com/SupportAssist**.

BOSS card

Introduction to BOSS card

BOSS is a simple RAID solution card designed specifically for booting a server's operating system. The card supports up to two 6 Gbps M.2 SATA drives. The BOSS adapter card has a x8 connector using PCIe gen 2.0 x2 lanes, available only in the low-profile and half-height form factor. The BOSS modular card has a dedicated slot in blade servers.

NOTE: There are no status LEDs on the BOSS card.

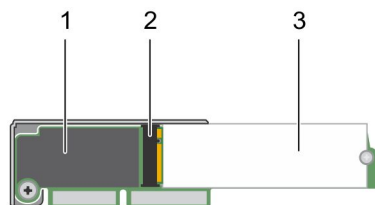

Figure 43. Features of BOSS card

- 1 BOSS card
- 2 M.2 SATA drive connector
- 3 80 mm M.2 SATA drive

Supported operating systems

The BOSS card supports the following minimum supported versions of operating systems:

- Microsoft Windows Server 2016
- VMware ESXi 6.0 Update 3
- VMware ESXi 6.5

NOTE: For the latest list of supported operating systems and driver installation instructions, see the system documentation at Dell.com/support/operatingsystemmanuals. For specific operating system service pack requirements, see the Drivers and Downloads section at Dell.com/support/manuals.

Supported XC Series systems

The following XC Series systems support the BOSS adapter card:

- XC640
- XC6420

- XC740xd
- XC940

BOSS card features

BOSS card supports the following features:

- Foreign Import
- SMART Info
- Auto-Rebuild

Foreign Import

A virtual disk is considered foreign if it is not native to the adapter.

- A virtual disk is considered native to the adapter if:
 - The virtual disk was created or imported on the adapter.
- A physical disk is considered native to the adapter if:
 - There is no previous virtual disk metadata on the adapter and the physical disk(s) are unconfigured.
 - All configured virtual disk(s) on the physical disk(s) are deleted.

SMART Info

SMART monitors certain physical aspects of all motors, heads, and physical disk electronics to help detect predictable physical disk failures. Data on SMART-compliant physical disks can be monitored to identify changes in values and determine whether the values are within threshold limits. Many mechanical and electrical failures display some degradation in performance before failure.

A SMART failure is also referred to as predicted failure. There are numerous factors that are predicted physical disk failures, such as a bearing failure, a broken read/write head, and changes in spin-up rate. In addition, there are factors related to read/write surface failure, such as seek error rate and excessive bad sectors.

Auto-Rebuild

A virtual disk rebuild will begin on system boot automatically if the native virtual disk is degraded and a valid rebuild target is present. A valid rebuild target is any functional drive attached to the BOSS-S1 device which is not part of the native virtual disk and is of equal or greater storage capacity. An auto-rebuild occurs without prompting the user, and any data on the rebuild target is overwritten.

BOSS card replacement by using Foreign Import option

Prerequisites

- 1 Stop the cluster and power off the node that needs the BOSS card replaced.
- 2 Remove the BOSS card and both M.2 SSD cards.
- 3 Connect the same M.2 SSD cards to the new BOSS card.
- 4 Connect the new BOSS card to the node, and then power on the node.

Steps

- 1 Turn on, or restart your appliance. Press F2 immediately after you see this message: F2 = System Setup, and then select **Device Settings**.
- 2 Select **AHCI Controller Configuration Utility**.
- 3 Select **<Virtual Disk Info>**, to view the virtual disk.

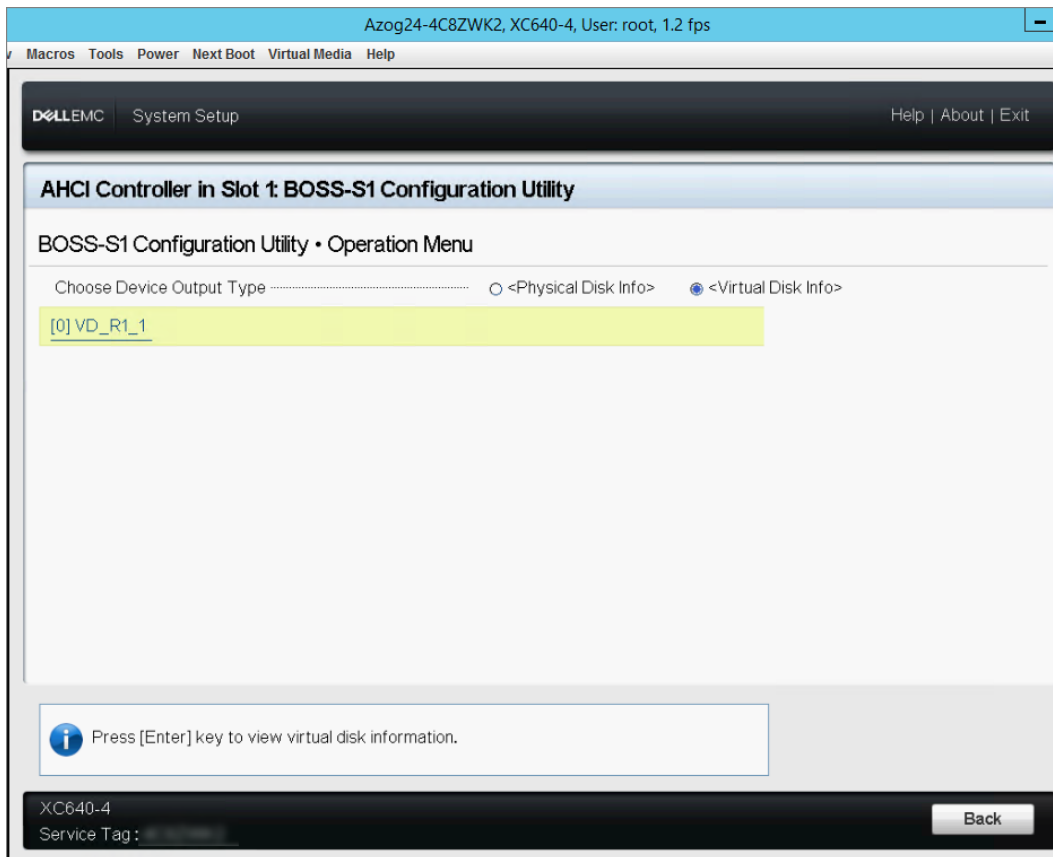

Figure 44. BOSS configuration utility

- 4 Click virtual disk. The status of the virtual disk is **Foreign**, and then click **Import**.

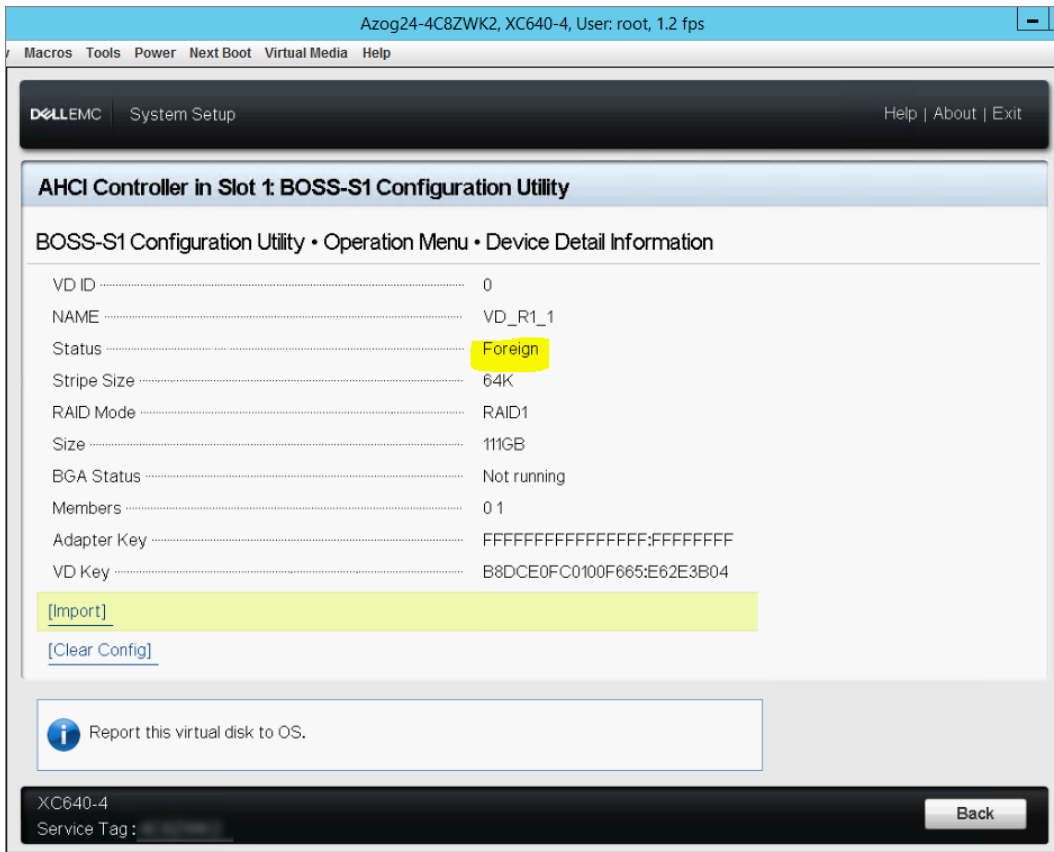

Figure 45. Virtual disk detail information

- 5 Click **Back** to go to the Virtual Disk info screen. Again, click virtual disk to view the status as **Functional**.

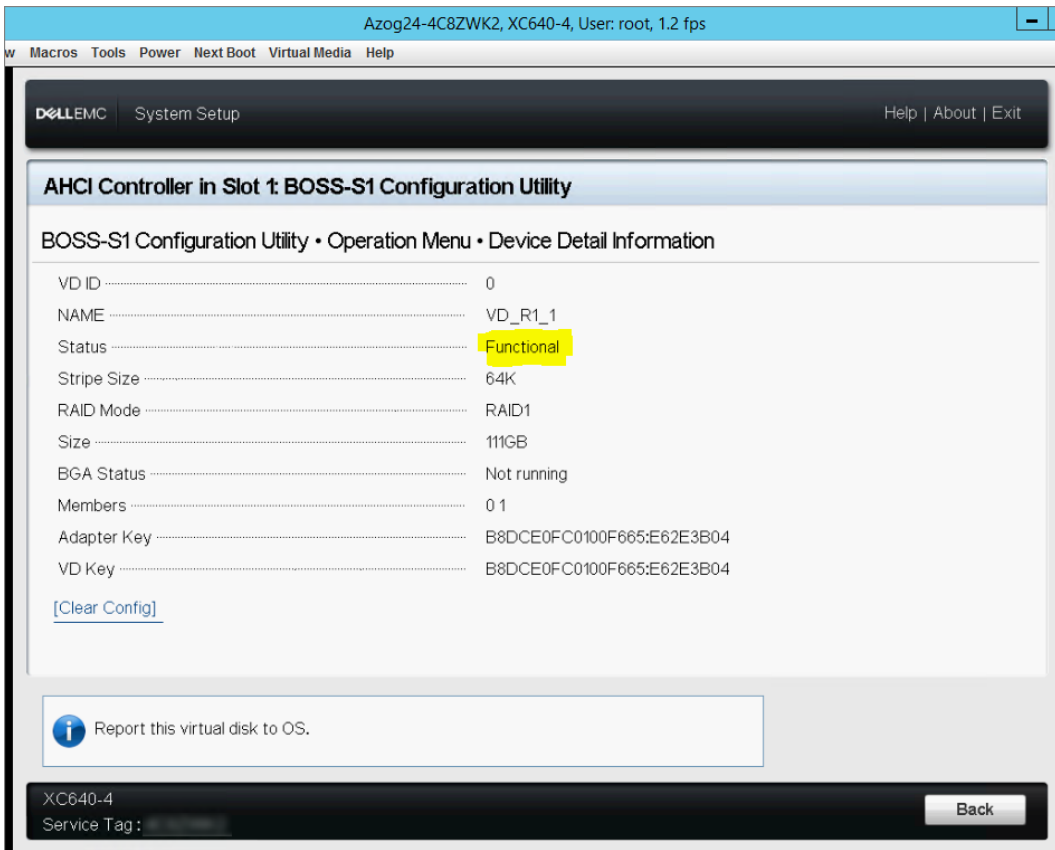

Figure 46. Virtual disk status

Next steps

① **NOTE:** If you connect a brand new BOSS card, you have to upgrade all the firmware to latest available versions.

- 1 Go to **iDRAC System Inventory** and verify that BOSS card is up to date.
- 2 Turn on, or restart your appliance. Press F2 immediately after you see this message: F2 = System Setup, and then select Boot Settings.
- 3 Change the boot order so that the BOSS card is first.

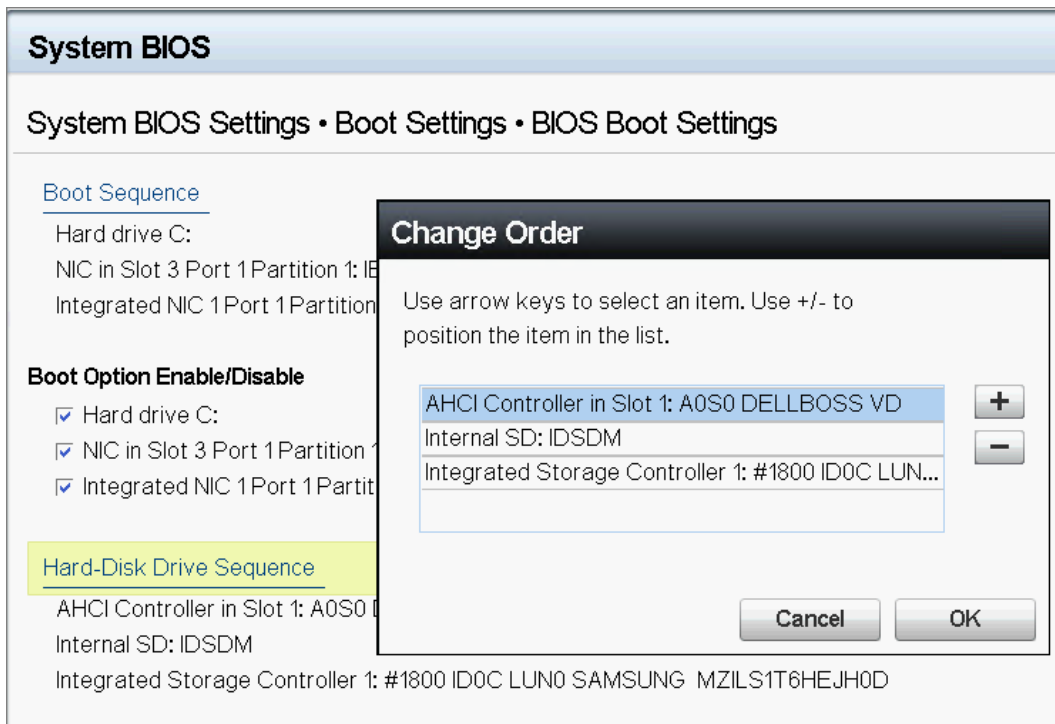

Figure 47. BOSS card boot order

- 4 Reboot the system and verify it boots into ESX.
- 5 Log in to the CVM and start the cluster.
- 6 Verify that Prism Hardware Diagram displays all nodes are detected.

Driver installation

The BOSS card uses the native AHCI driver of the supported operating systems.

Windows driver installation — Dell provides the Dell Update Package (DUP) to update drivers on systems running Windows Server 2012 R2 and newer operating system. DUP is an executable application that updates drivers for specific devices. DUP supports command line interface and silent execution. For more information, see Dell.com/support.

NOTE: For more information about supported drivers, see the Support Matrix available at Dell.com/XCSeriesmanuals.

BOSS troubleshooting

To get help with your Dell EMC BOSS card, you can contact your Dell EMC Technical Service representative or see Dell.com/support.

Physical disks not visible to operating system

Issue: One or both physical disks are not appearing for use by an operating system.

Probable cause: A physical disk will not be presented to the operating system in the following scenarios:

- There is RAID metadata on the physical disk and no RAID metadata on the controller.
- The BOSS controller has RAID metadata on it and the physical disks do not have the RAID metadata on it.

Corrective action: If the RAID metadata is on the controller, clear the controller configuration.
If the RAID metadata is on the physical disk, erase the data available in physical disk.

Alternatively, if you want to keep the RAID drives, see [Virtual disk not visible to operating system](#).

Virtual disk not visible to operating system

Issue: In RAID mode a virtual disk is not appearing for use by an operating system.

Probable cause: Virtual disks will not be presented to the system if they are not native to the controller.

Corrective action: Import the virtual disk using Hardware-Independent Imaging (HII).

Drive failure

Issue: An installed drive is not listed in the BOSS configuration utility.
OpenManage reports **Physical Disk offline** state.

Probable cause: Drive is either in failure state or has corrupted firmware.

Corrective action: Reseat drive to ensure drive is inserted correctly. If error persists, attempt to update drive firmware using DUP. If error is still present, replace erroneous drive.

Fault in controller

Issue: Controller's UEFI Configuration Utility Menu entry is not appearing.

Probable cause: Either a firmware or a hardware fault

Corrective action:

- 1 Flash the latest firmware on the BOSS adapter.
- 2 If the problem persists, shutdown the system, and then unplug the BOSS adapter.
- 3 Plug the BOSS adapter into the PCIe slot.
- 4 Boot the system and check the UEFI Configuration Utility Menu again.

If the problem still persists, see [BOSS card is not detected](#).

NOTE: Ensure that the system is completely disconnected from all power sources before making any hardware changes.

NOTE: If you replace the SAS HBA330 controller you must update to the latest HBA firmware version.

BOSS card is not detected

Issue: BOSS device is not detected in the system.

Probable cause: Hardware fault on the card.

Corrective action: Replace the BOSS adapter with a new one.

Unable to boot to M.2 drive installed in slot 1

- Issue:** When two unconfigured bootable M.2 drives are inserted into the BOSS device, only the slot 0 drive boots.
- Probable cause:** Working as designed, BIOS only allows booting from the first listed boot device (in this case, slot 0) per peripheral controller. This only occurs in legacy BIOS boot mode.
- Corrective action:** Swap the drive in slot 1 to slot 0.

CLI reports unsupported features

- Issue:** Several commands, options, or other features listed by the Marvell CLI state that they are unsupported when run.
- Probable cause:** CLI shows the same information on all Marvell products, but only implements the functions which are pertinent to that platform or system.
- Corrective action:** Use supported features.