

Venue 8 Pro

User's Guide - Windows 10



Notes, cautions, and warnings

 **NOTE:** A NOTE indicates important information that helps you make better use of your tablet.

 **CAUTION:** A CAUTION indicates either potential damage to hardware or loss of data and tells you how to avoid the problem.

 **WARNING:** A WARNING indicates a potential for property damage, personal injury, or death.

1 Features	5
2 Setting up your tablet	7
Charging the tablet	7
Power and battery-charge status light behavior	7
Power and battery-charge status light icons	8
Turning on your tablet	8
Inserting a micro-SIM card	8
Removing the micro-SIM card	9
Inserting a microSD card	9
Removing the microSD card	10
Using headphones	10
3 Using your tablet	12
Turning off your tablet	12
Using the power button on the Start screen	12
Using the power button	12
Turning off the screen	12
Using the power button on the Start screen	12
Using the power button	12
Start screen	12
Wi-Fi	13
Turning Wi-Fi on or off	13
Connecting to a network	13
Mobile broadband setting	13
Bluetooth	13
Turning Bluetooth on or off	13
Pairing with Bluetooth-enabled devices	13
Screen orientation	14
Locking or unlocking the screen orientation	14
Adjusting screen brightness	14
Auto adjust	14
Synchronizing your tablet	14
Restoring your operating system	14
Resetting your tablet	15
Gestures	15
4 Troubleshooting	17
Battery problem	17
Network problem	17
Touchscreen problem	18
System problem	18
5 Entering BIOS setup program	19

With keyboard.....	19
Without keyboard.....	19
6 Specifications.....	20
7 Getting help	22
Contacting Dell.....	22
8 Locating your Service Tag and Express Service Code.....	23

Features

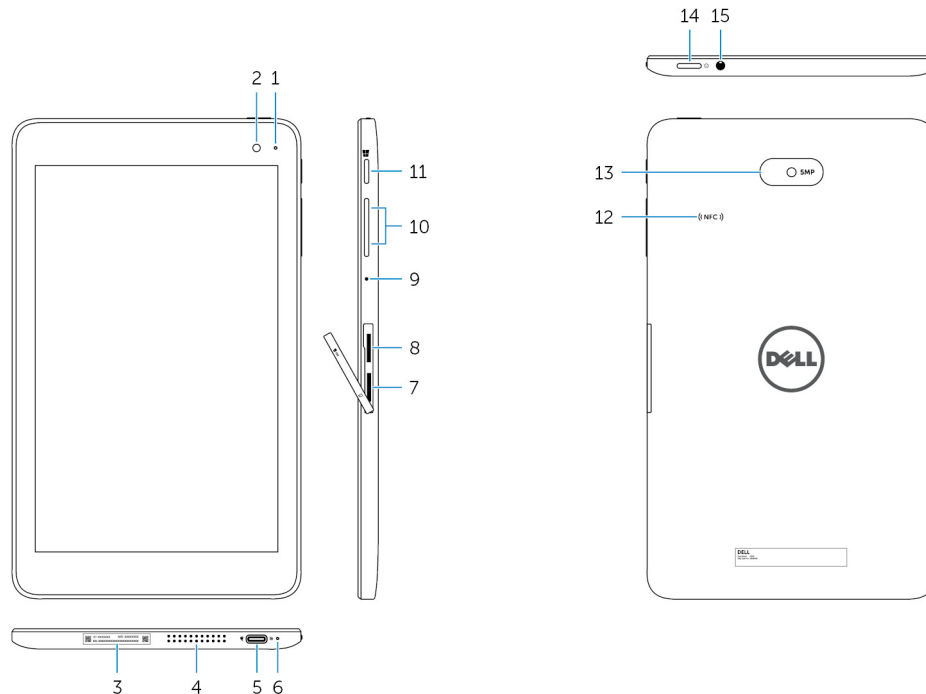

Feature

1.	Camera-status light	Turns on when the front camera or rear camera is in use.
2.	Front camera	Allows you to capture photos, and record videos.
3.	Service Tag label	Provides the Service Tag and Express Service Code needed when contacting Dell.
4.	Speaker	Provide audio output.
5.	USB 3.0 and power-adaptor port (USB-C)	Connect a power adapter to provide power to your tablet and charge the battery. Connect peripherals such as storage devices, printers, displays and so on. Provides data transfer speeds up to 5 Gbps. NOTE: You need to use converters (sold separately) to connect standard USB, HDMI, and DisplayPort devices.
6.	Power and battery-charge status light	Indicates the power-state and the battery-charging status of the tablet.
7.	Micro-SIM card slot	Insert a micro-SIM card to connect to a mobile broadband network.
8.	microSD card slot	Insert a microSD card to expand the tablet's storage capacity. Your tablet supports a microSD card with capacity up to 128 GB.
9.	Microphone	Provides sound input for audio recording, voice calls, and so on.
10.	Volume-control buttons (2)	Press to increase or decrease the volume.
11.	Windows button	<ul style="list-style-type: none"> Press to open the Windows Start screen. Press for quick access to the most recently used app or most recently used screen.
12.	NFC-sensor area (optional)	Near Field Communication feature allows you to share files wirelessly with other NFC-compatible devices.

Feature

- | | | |
|-----|--------------|---|
| 13. | Rear camera | Allows you to capture photos, and record videos. |
| 14. | Power button | <ul style="list-style-type: none">• Press and hold for 2 seconds to turn on the tablet if it is turned off.• Press to turn on the tablet if it is in sleep state.• Press to put the tablet in sleep state if it is turned on. |
| 15. | Headset port | Connect a headphone, a microphone, or a headphone and microphone combo (headset). |

Setting up your tablet

WARNING: Before you begin any of the procedures in this section, read the safety information that shipped with your tablet. For additional best practices information, go to www.dell.com/regulatory_compliance.

Charging the tablet

CAUTION: Charge the battery in an ambient temperature of 0°C to 35°C (32°F to 95°F).

CAUTION: Use only the supplied power adapter to charge your tablet. Using unauthorized power adapters or cables may severely damage your tablet.

NOTE: The battery may not be fully charged when you unpack your tablet.

1. Connect the power cable into the power adapter.
2. Connect the power adapter to the power-adaptor port on the tablet.
3. Connect the power adapter to an electrical outlet and charge the tablet until the battery is fully charged.

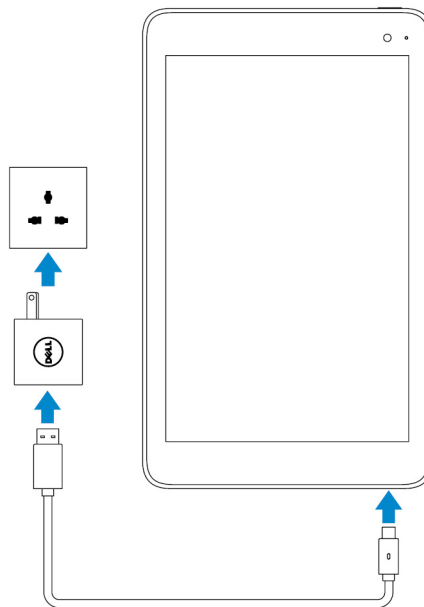

NOTE: A fully discharged battery takes about 4 to 5 hours to fully charge.

Power and battery-charge status light behavior

You can check the power and battery-charge status from the battery-charging status light or the battery icon displayed at the bottom of the Windows desktop:

Behavior

Solid white

Solid amber

Description

Battery is getting charged.

Battery charge is critically low and the tablet is off.





NOTE: If you try turning on the tablet when the battery charge is critically low and the battery is insufficiently charged, the Dell

logo flashes on the screen, the battery-charging status light illuminates for 2 seconds, and then the tablet turns off.

Off

Battery is not getting charged or battery is fully charged.

Power and battery-charge status light icons

Icon	Description
	Tablet is connected to a power supply and the battery is fully charged.
	Tablet is connected to a power supply and the battery is getting charged.
	Tablet is running on the battery power and the battery is discharging.
	Tablet is running on the battery power and the battery charge is low.
	Tablet is running on the battery power and the battery charge is critically low.

Turning on your tablet

When you turn on the tablet for the first time, you must finish Windows setup to start using your tablet. For more information, see the Quick Start Guide that shipped with your tablet.

1. Press and hold the power button for 2 seconds to turn on your tablet. The lock screen appears.
2. Swipe up from the bottom of the display to switch to the login screen select your account and enter your password to log in to Windows.

 **NOTE:** If the login screen is not enabled, the Start screen appears when you swipe up on the lock screen.

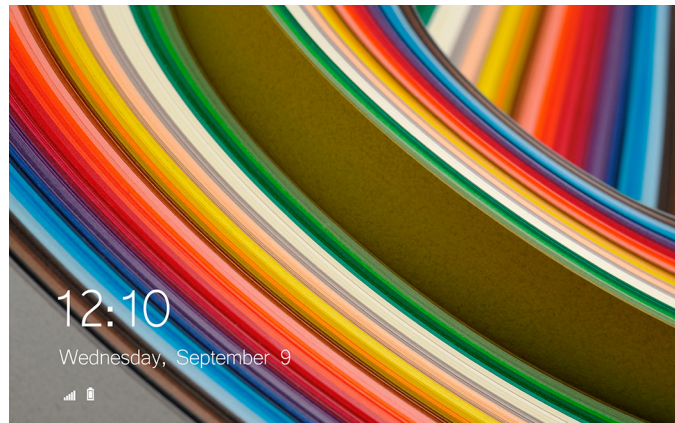

The tablet is ready for use when the Windows Start screen is displayed.

Inserting a micro-SIM card

1. Open the slot cover and locate the micro-SIM card slot.

 **CAUTION:** Ensure that the micro-SIM card is aligned as shown in the image.

2. Insert the micro-SIM card into the card slot until it locks into place.
3. Close the slot cover.

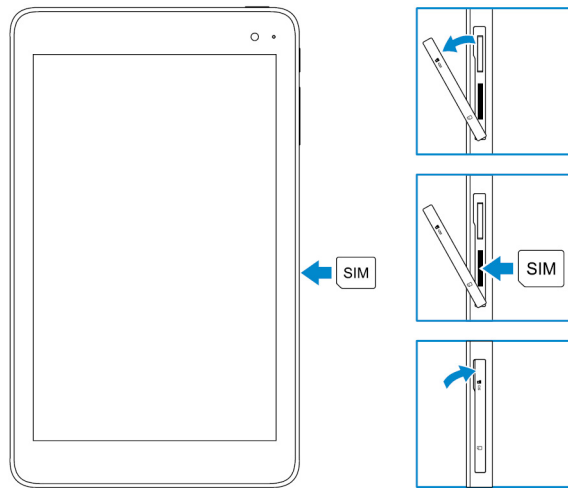

Removing the micro-SIM card

CAUTION: Removing the micro-SIM card while it is in use may cause data loss or result in application errors.

1. Open the slot cover.
2. Press the micro-SIM card inward and release it.
The micro-SIM card pops out.
3. Slide the micro-SIM card out of the slot.
4. Close the slot cover.

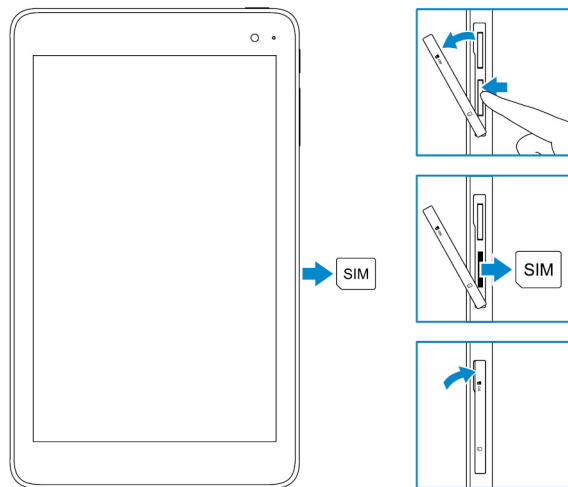

Inserting a microSD card

NOTE: Turn off your tablet before inserting the microSD card.

1. Open the slot cover and locate the microSD card slot.

CAUTION: Ensure that the microSD card is aligned as shown in the image.

2. Insert the microSD card into the card slot until it locks into place.
3. Close the slot cover.

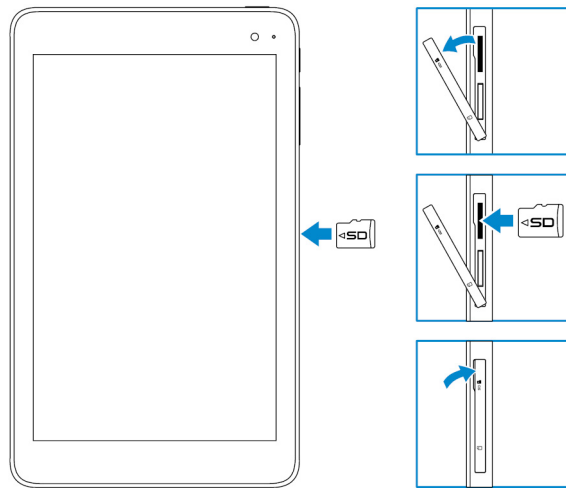

Removing the microSD card

CAUTION: Removing the microSD card while it is in use may cause data loss or result in application errors.

1. In the notification area at the bottom-right corner of the Windows desktop, tap  (Safely Remove Hardware and Eject Media).

NOTE: If you do not see Safely Remove Hardware and Eject Media, tap Show hidden icons to display all icons in the notification area.

2. Tap **Eject SD Memory Card**. A message appears confirming that the microSD card can be safely removed.

NOTE: If a warning message appears stating the microSD card cannot be removed, ensure all data transfers involving the microSD card are complete.

3. Open the slot cover.
4. Press the microSD card inward and release it. The microSD card pops out.
5. Slide the microSD card out of the slot.
6. Close the slot cover.

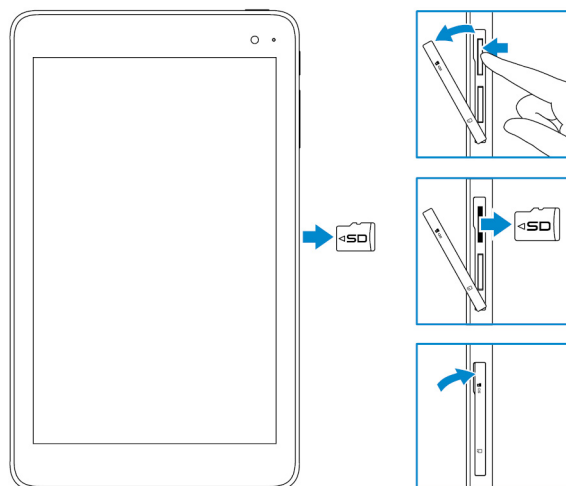

Using headphones

WARNING: Listening to loud audio for an extended period of time can lead to hearing loss.

You can connect a headset, headphones, microphone, or other audio equipment to the headset port of your tablet.

1. Connect headphones to the headset port on the tablet.
2. Insert the earphones in your ears and adjust the volume to a comfortable level.

CAUTION: To prevent damaging your headphones when disconnecting it from the tablet, pull the connector and not the cable.

NOTE: When you connect an audio device to the headset port, the integrated speaker on your tablet is muted automatically.

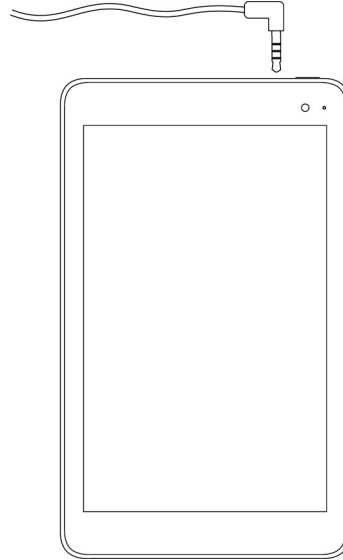

Using your tablet

 **NOTE:** For detailed information on using Windows, see [Getting help](#).

Turning off your tablet

Using the power button on the Start screen

1. Tap **Start**.
2. Tap the power button  → **Shut down** to turn off the tablet.

Using the power button

1. Press and hold the power button for at least 4 seconds.
2. Swipe down the shut-down confirmation screen to turn off the tablet.

Turning off the screen

Using the power button on the Start screen

1. Tap **Start**.
2. Tap the power button  → **Sleep** to turn off the screen.

 **NOTE:** If your tablet is in a standby state, press the power button or Windows button to turn on the screen.

Using the power button

Press the power button to turn off the screen.

Start screen

The Start screen displays tiles that act as shortcuts to installed apps.

 **NOTE:** You can disable or enable tablet mode using the icon in the Action center. You can also choose to automatically switch to PC mode when the tablet is docked. When in PC mode, the Start screen is replaced by the Start menu. To learn more about using Windows, see [Getting help](#).

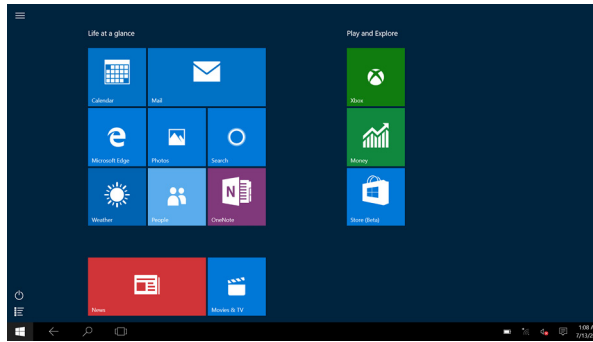

Tiles on your Start screen change and update in real time to show news and sports updates, weather updates, social-networking feeds, and so on.

You also can customize the Start screen by pinning your favorite apps as tiles, setting your favorite picture as a wallpaper, and so on.

Wi-Fi

Turning Wi-Fi on or off

1. Swipe-in from the right edge of the display to access the Action Center.
2. Tap  to turn Wi-Fi on or off.

Connecting to a network

1. Tap Wi-Fi icon  in the bottom-right corner of the screen.
2. In the list of available networks, tap the network you want to connect to, and then tap **Connect**.

Mobile broadband setting

1. Tap **Network**  in the bottom-right corner of the screen.
2. Under **Cellular** tap your mobile broadband carrier and then tap **Connect**.
3. In the advanced options tap **Connect**.

Bluetooth

Turning Bluetooth on or off

1. Swipe-in from the right edge of the display to access the Action Center.
2. Tap **Bluetooth**  to turn Bluetooth off or on.

Pairing with Bluetooth-enabled devices

 **NOTE: Bluetooth connection between your tablet and Apple devices are not supported.**

1. Turn on Bluetooth. For more information, see [Turning on/off Bluetooth](#).
2. Swipe-in from the right edge of the display to access the Action Center.
3. Press and hold **Bluetooth**  and then tap **Go to settings**.
4. From the list of devices, tap the device you want to pair with and tap **Pair**.
5. If needed, verify that the Bluetooth passcode that appears on both the tablet and the Bluetooth-enabled device are the same.
6. Confirm the pairing process on both the tablet and device.

 **NOTE:** After a device is successfully paired with the tablet, it automatically connects with the tablet when Bluetooth is enabled on both tablet and device and they are in Bluetooth range.

Screen orientation

For optimal viewing experience, the screen orientation changes automatically to portrait or landscape depending on how you hold the tablet. You can disable automatic screen rotation and lock the screen in portrait or landscape mode.

 **NOTE:** Some apps may not support automatic screen rotation and are designed to work only in one orientation.

Locking or unlocking the screen orientation

1. Swipe-in from the right edge of the display to access the Action Center.
2. Tap  to lock or unlock the screen orientation.

Adjusting screen brightness

1. Swipe-in from the right edge of the display to access the Action Center.
2. Tap the brightness icon  to adjust the screen brightness.

Auto adjust



To enable or disable automatic screen brightness adjustment:

1. Swipe-in from the right edge of the display to access the Action Center.
2. Tap **All Settings**  → **System** → **Display**.
3. Use the **Adjust my screen brightness automatically** slider to enable or disable automatic-brightness adjustment.

 **NOTE:** You can also use the Brightness level slider to adjust the brightness manually.

Synchronizing your tablet

When you use your Microsoft account to sign in to devices, the settings such as Windows and app settings and personal files are automatically synchronized.

 **NOTE:** To synchronize, the devices must be connected to the internet. If you are using a local account, switch to a Microsoft account to enable synchronization. On the Settings screen, tap **Accounts** . On the Accounts screen, tap **Manage my Microsoft Account** to switch to your Microsoft account.

To customize the synchronizing settings:

1. Swipe-in from the right edge of the display to access the Action Center.
2. Tap **All settings** .
3. On the **Accounts** screen, tap **Sync your settings** to see the options for synchronizing your data and settings.

Restoring your operating system

You may need to reinstall the operating system if your tablet is not responding, behaving unexpectedly, or has other software-related issues. You can choose to save your personal files while restoring or you can return the operating system in the state you received it from Dell.

Resetting your tablet

CAUTION: Back up all the required data before you proceed.

You can either reset your tablet to restore it to the state you received it or you can choose to retain your files.

1. Swipe-in from the right edge of the display to access the Action Center.
2. Tap **All Settings**  → **Update and Security** → **Recovery**.
3. Under **Reset this PC**, tap **Get started**.
4. Choose either **Keep my files** or **Remove everything**.

NOTE: The option **Keep my files** removes apps and settings, but keeps your personal files. The option **Remove everything** removes all of your personal files, apps, and settings.

5. Follow the instructions on the screen.

Gestures

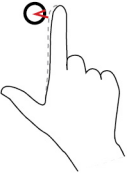
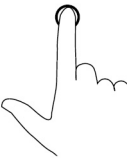
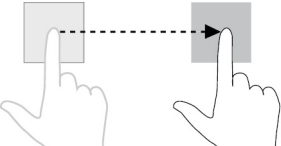
Gestures	Functions
<p>Touch</p> <p>Tap gently on the display with your fingertip.</p> 	<ul style="list-style-type: none"> • Select items on the screen including options, entries, images, and icons. • Start applications. • Touch buttons on the screen. • Input text using the on-screen keyboard.
<p>Touch and hold</p> <p>Touch and hold your finger on the display.</p> 	<ul style="list-style-type: none"> • Display detailed information about an item. • Open the context menu of an item to perform further actions.
<p>Drag</p> <ol style="list-style-type: none"> 1. Touch and hold your finger on an item on the screen. 2. Keeping your finger in contact with the display, move your fingertip to the desired location. 3. Take your finger off the display to drop the item in the desired location. 	<p>Move items such as images and icons on the screen.</p>
<p>Swipe or slide</p> <p>Move your finger in a vertical or horizontal direction on the display.</p>	<ul style="list-style-type: none"> • Scroll through the Start screen, web pages, lists, entries, photos, contacts, and so on. • Close an application (Swipe the application to the bottom of the display).

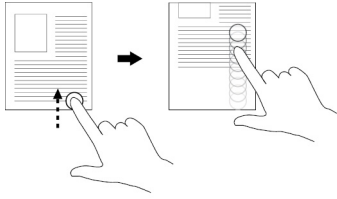
Gestures**Functions****Zoom in**

Touch the display with two fingers and then move the fingers apart.

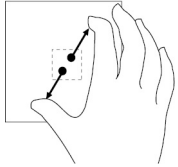

Enlarge the view of an image or web page.

Zoom out

Touch the display with two fingers and then move the fingers closer.

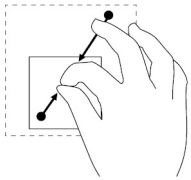

Reduce the view of an image or web page.

Rotate

Touch the display with two or more fingers and then move the fingers in a clockwise or counter-clockwise arc.

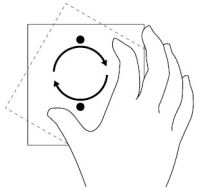

Rotate an object by 90 degrees.

Troubleshooting

Battery problem

Problems	Possible causes	Possible solutions
Battery does not charge	The cable connections may be loose.	<ol style="list-style-type: none"> 1. Check the cable, connectors, and power adapter to ensure proper connectivity. 2. Verify that the wall outlet is functioning by connecting another device.
	The tablet's temperature is below 0°C (32°F) or higher than 35°C (95°F).	Charge the battery in an ambient temperature between 0°C to 35°C (32°F to 95°F).
	The battery or power adapter is damaged.	Contact Dell. See Contacting Dell .
Battery does not charge when the battery charge is at 95% to 99%	The battery is in maintenance mode to prolong battery life.	<ul style="list-style-type: none"> • Let the battery drain until the battery charge drops below 95%. • Restart the tablet. See Turning off your tablet and Turning on your tablet.
Battery drains quickly even when the tablet is in standby mode	If the tablet is not in the range of a network it can connect to, the tablet continues to try to locate a base station and drains the battery.	<ul style="list-style-type: none"> • Temporarily turn off the tablet. • Move the tablet in range of a network it can connect to or temporarily turn off the wireless connection on your tablet. • Disable Wi-Fi or mobile broadband when not in range of any wireless networks. • Enable airplane mode.
Battery charge values are not accurate	Move the tablet in range of a network it can connect to or temporarily turn off the wireless connection on your tablet.	<ul style="list-style-type: none"> • Press and hold the power button for 10 seconds to forcefully turn off the tablet, and force the system to obtain a new reference point for the battery charge value (do not follow the regular Windows shutdown process). • Perform a full battery charge/discharge cycle to recalibrate the battery charge value by charging the tablet until the battery is fully charged and run the battery power until the tablet shuts itself down.
Battery is fully charged (battery charge is at 100%) but the battery-charging status light is on		
Battery charge jumps from 90% to 100% when the battery is charging		

Network problem

Problems	Possible causes	Possible solutions
No wireless connection		<ul style="list-style-type: none"> • Check if the wireless radio is on. See Wi-Fi. • Try to get closer to the wireless access point.

Slow internet connections	The signal strength is not strong enough.	Contact your internet service provider (ISP).
Unable to pair with a Bluetooth device		<ul style="list-style-type: none"> • Ensure Bluetooth is enabled on both the tablet and the device you are trying to pair with. • Ensure they are within Bluetooth range.

Touchscreen problem

Problems	Possible causes	Possible solutions
Touchscreen responds slowly or improperly	<ul style="list-style-type: none"> • The screen is dirty. • A protective cover may prevent the tablet from recognizing your inputs. 	<ul style="list-style-type: none"> • Moisten a soft, lint-free cloth with either water or a display cleaner, and wipe the surface of the tablet until it is clean. Do not allow water from the cloth to seep down to the tablet ports or buttons. • Moisten a soft, lint-free cloth with either water or a display cleaner, and wipe the surface of the tablet until it is clean. Do not allow water from the cloth to seep down to the tablet ports or buttons.

System problem

Problems	Possible causes	Possible solutions
Tablet does not turn on	The battery is completely discharged.	<ul style="list-style-type: none"> • Charge the tablet for at least 4 hours. • Press and hold the power button for 2 seconds.
Tablet does not turn off		Press and hold the power button for 10 seconds to forcefully turn off the tablet.
Tablet locks up		Press and hold the power button for 10 seconds to forcefully turn off the tablet.
Tablet is not responding or behaving unexpectedly		<ul style="list-style-type: none"> • Restart the tablet. See Turning off your tablet and Turning on your tablet. • Refresh the tablet. See Restoring your operating system.
Tablet cannot boot into Windows		Contact Dell's support service. Go to www.dell.com/contactdell .
Software or feature is not working as expected		Software updates may have been downloaded in the background. Restart your tablet.

Entering BIOS setup program

With keyboard

1. Connect your tablet to the keyboard dock or connect a USB enabled keyboard to your tablet.
2. Press the power button to turn on your tablet.
3. When the Dell logo appears, press F2.

Without keyboard

1. Press the power button to turn on your tablet.
2. Press and hold the Volume Up button when the Dell logo appears on the screen.
3. When the F12 boot selection menu appears, select **BIOS Setup** using the Volume Up button.
4. Press the Volume Up button to enter BIOS setup program.

Specifications

Dimensions and weight		
Height		216 mm (8.50 in)
Width		130 mm (5.11 in)
Depth		9.45 mm (0.37 in)
Weight (maximum):		
	WiFi	0.395 kg (0.87 lb)
	WWAN	0.405 kg (0.89 lb)

System information		
Processor		Intel Cherry Trail-T CPU Z8500
Operating system		<ul style="list-style-type: none"> • Windows 8.1 • Windows 10
RAM		LPDDR3
Storage		<ul style="list-style-type: none"> • 32 GB eMMC • 64 GB eMMC

Memory		
Type		LPDDR3
Speed		1600 MHz
Configurations supported		2 GB and 4GB

Ports and connectors		
Audio		One headset port (headphone and microphone combo)
microSD card		One microSD-card slot
micro-SIM card		One micro SIM-card slot
USB		One USB Type C

Communications		
Wi-Fi		Dual-band 802.11b/g/n/ac
Bluetooth		Bluetooth 4.1 LE

Display		
	8" WXGA	8" WUXGA
Type	TFT LCD (Wide View Angle Technology)	TFT LCD (Wide View Angle Technology)
Luminance (typical)	400 nits	400 nits
Dimensions:		

Display			
	Height (maximum)	184.90 mm (7.28 in)	184.90 mm (7.28 in)
	Width (maximum)	114.90 mm (4.52 in)	114.90 mm (4.52 in)
	Diagonal	203.20 mm (8 in)	203.20 mm (8 in)
Native resolution		800 x 1280	1200 x 1920
Megapixels		1.0	2.3
Pixels per inch (PPI)		189	283
Contrast ratio (minimum)		800:1	800:1
Response time (maximum)		30 ms	30 ms
Refresh rate		60 Hz	60 Hz
Color depth		True 8 bits	True 8 bits

Camera			
Webcam type		Front-facing camera	Rear-facing camera
Camera type		FHD fixed focus	5 M auto focus
Sensor type		CMOS sensor technology	CMOS sensor technology
Resolution of motion video		Up to 1920 x 1080 (2.1 MP)	Up to 1920 x 1080 (2.1 MP)
Resolution of still image		Up to 1920 x 1080 (2.1 MP)	Up to 2592 x 1944 (5 MP)
Imaging rate		Up to 30 frames per second	Up to 30 frames per second



Power adapter			
Input voltage		100 VAC–240 VAC	
Input frequency		50 Hz–60 Hz	
Input current		0.3 A	
Output current		2.0 A	
Rated output voltage		5.0 VDC	
Temperature range:			
	Operating	0°C to 40°C (32°F to 104°F)	
	Storage	–40°C to 70 °C (–40°F to 158°F)	

Environmental requirements			
Temperature range:			
	Operating	0°C to 35 °C (32°F to 95 °F)	
	Non-operating	–40°C to 65 °C (–40°F to 149 °F)	
Relative humidity (maximum):			
	Operating	10% to 90% (non-condensing)	
	Non-operating	5% to 95% (non-condensing)	
Altitude (maximum, unpressurized):			
	Operating	–15.20 m to 3048 m (–50 ft to 10,000 ft)	
	Storage	–15.20 m to 10,668 m (–50 ft to 35,000 ft)	

Getting help

Self-help resources

You can get information and help on Dell products and services using these self-help resources:

Information about Dell products and services	www.dell.com
Dell Help & Support app	
Get started app	
Help + Tips app	
Accessing help	In Windows search, type Help and Support , and tap Enter .
Online help for operating system	www.dell.com/support/windows
Troubleshooting information, user manuals, setup instructions, product specifications, technical help blogs, drivers, software updates, and so on	www.dell.com/support
Learn about your operating system, setting up and using your tablet, data backup, diagnostics, and so on.	See <i>Me and My Dell</i> at www.dell.com/support/manuals .

Contacting Dell

To contact Dell for sales, technical assistance, or customer service issues:

1. Go to www.dell.com/contactdell.
2. Verify your country or region in the **Choose a Country/Region** drop-down list at the bottom of the page.
3. Select the appropriate service or support link based on your requirement or choose the method of contacting Dell that is convenient for you.

Dell provides several online and telephone-based support and service options. Availability varies by country and product, and some services may not be available in your area.

 **NOTE:** If you do not have an active internet connection, you can find contact information on your purchase invoice, packing slip, bill, or Dell product catalog.

Locating your Service Tag and Express Service Code

You must provide the Service Tag and Express Service Code of your tablet when contacting Dell for customer service or technical assistance.

NOTE: The telephone systems prompts you to enter the Express Service Code that helps in routing your call efficiently.

The Service Tag and Express Service Code for your tablet are located on a label at the bottom of the tablet.

