

Dell DR4300 System

Owner's Manual

Notes, cautions, and warnings

 **NOTE:** A NOTE indicates important information that helps you make better use of your computer.

 **CAUTION:** A CAUTION indicates either potential damage to hardware or loss of data and tells you how to avoid the problem.

 **WARNING:** A WARNING indicates a potential for property damage, personal injury, or death.

© 2016 Dell Inc. All rights reserved. This product is protected by U.S. and international copyright and intellectual property laws. Dell and the Dell logo are trademarks of Dell Inc. in the United States and/or other jurisdictions. All other marks and names mentioned herein may be trademarks of their respective companies.

1 Dell DR4300 system overview.....	8
Front panel features and indicators.....	8
Back panel features.....	9
Diagnostic indicators on the front panel.....	11
Hard drive indicator codes.....	12
NIC indicator codes.....	13
Power supply unit indicator codes.....	13
iDRAC Direct LED indicator codes.....	15
Quick Sync indicator codes.....	16
Locating Service Tag of your system.....	16
Documentation matrix.....	16
2 Technical specifications.....	18
Chassis dimensions.....	18
Chassis weight.....	18
Processor specifications.....	19
PSU specifications.....	19
System battery specifications.....	19
Expansion bus specifications.....	19
Memory specifications.....	19
Drive specifications.....	20
Hard drives.....	20
Ports and connectors specifications.....	20
USB ports.....	20
NIC ports.....	20
Serial connector.....	20
VGA ports.....	20
Internal Dual SD Module.....	20
Video specifications.....	20
Environmental specifications.....	21
Particulate and gaseous contamination specifications	22
Standard operating temperature.....	22
Expanded operating temperature.....	22
Expanded operating temperature restrictions.....	23
3 Initial system setup and configuration.....	24
Setting up your system.....	24
iDRAC configuration.....	24
Options to set up iDRAC IP address.....	24
Options to install the operating system.....	25
Methods to download firmware and drivers.....	25
Manage your system.....	26
4 Pre-operating system management applications.....	27

Options to manage the pre-operating system applications.....	27
System Setup.....	27
Viewing System Setup.....	27
System Setup details.....	28
System BIOS.....	28
iDRAC Settings utility.....	50
Device Settings.....	51
Dell Lifecycle Controller.....	51
Embedded system management.....	51
Boot Manager.....	52
Viewing Boot Manager.....	52
Boot Manager main menu.....	52
PXE boot.....	53
5 Installing and removing system components.....	54
Safety instructions.....	54
Before working inside your system.....	54
After working inside your system.....	54
Recommended tools.....	55
Front bezel (optional).....	55
Removing the optional front bezel.....	55
Installing the optional front bezel.....	57
System cover.....	57
Removing the system cover.....	57
Installing the system cover.....	58
Inside the system.....	59
Cooling shroud.....	60
Removing the cooling shroud.....	60
Installing the cooling shroud.....	61
Cooling fans.....	61
Removing a cooling fan.....	61
Installing a cooling fan.....	62
Cooling-fan assembly	63
Removing the cooling fan assembly.....	63
Installing the cooling fan assembly.....	64
System memory.....	65
General memory module installation guidelines.....	67
Mode-specific guidelines.....	67
Sample memory configurations.....	68
Removing memory modules.....	68
Installing memory modules.....	69
Processors and heat sinks.....	71
Removing a heat sink.....	71
Removing a processor.....	72
Installing a processor.....	76
Installing a heat sink.....	78
PCIe card holder.....	79
Removing the PCIe card holder.....	79
Installing the PCIe card holder.....	80
Opening and closing the PCIe card holder latch.....	81

Cable retention bracket.....	82
Removing the cable retention bracket.....	82
Installing the cable retention bracket.....	83
Integrated storage controller card.....	84
Removing the integrated storage controller card.....	84
Installing the integrated storage controller card.....	85
Expansion cards and expansion card riser.....	87
Expansion card installation guidelines.....	87
Removing an expansion card from expansion card riser 2 or 3.....	87
Installing an expansion card into the expansion card riser 2 or 3.....	89
Removing an expansion card from the expansion card riser 1.....	90
Installing an expansion card into the expansion card riser 1.....	92
Removing the riser 1 blank.....	93
Installing the riser 1 blank.....	94
Removing expansion card risers.....	95
Installing expansion card risers.....	99
Internal dual SD module (optional).....	101
Removing an internal SD card.....	101
Installing an internal SD card.....	102
Removing the optional internal dual SD module.....	103
Installing the optional internal dual SD module	105
Network daughter card.....	105
Removing the network daughter card	105
Installing the network daughter card.....	107
Internal USB memory key (optional).....	108
Replacing the optional internal USB memory key.....	108
System battery.....	109
Replacing the system battery.....	109
Power supply units (PSU).....	110
Hot spare feature.....	111
Removing the power supply unit blank.....	111
Installing the power supply unit blank.....	112
Removing an AC power supply unit.....	113
Installing an AC power supply unit.....	114
System board.....	115
Removing the system board.....	115
Installing the system board.....	117
Trusted Platform Module.....	120
Installing the Trusted Platform Module.....	120
Initializing the TPM for BitLocker users.....	121
Initializing the TPM for TXT users.....	121
Hard drives.....	122
Removing a 2.5 inch hard drive blank (rear).....	122
Installing a 2.5 inch hard drive blank (rear).....	123
Removing a 3.5-inch hard drive blank.....	123
Installing a 3.5-inch hard drive blank.....	124
Removing a hot swappable hard drive or SSD.....	125
Installing a hot-swap hard drive.....	126
Removing a hard drive from a hard drive carrier.....	127
Installing a hard drive into a hard drive carrier.....	128

Hard drive backplane.....	128
Removing the hard drive backplane	128
Installing the hard drive backplane	131
Removing the optional hard drive backplane (rear).....	132
Installing the optional hard drive backplane (rear).....	133
SD vFlash card (optional).....	134
Replacing an optional SD vFlash media card.....	135
Removing the vFlash media unit.....	135
Installing the vFlash media unit.....	136
Control panel assembly.....	137
Removing the control panel	137
Installing the control panel	139
Removing the I/O panel	140
Installing the I/O panel	141
6 Using system diagnostics.....	143
Dell Embedded System Diagnostics.....	143
When to use the Embedded System Diagnostics.....	143
Running the Embedded System Diagnostics from Boot Manager.....	143
Running the Embedded System Diagnostics from the Dell Lifecycle Controller.....	143
System diagnostic controls.....	144
7 Jumpers and connectors.....	145
System board jumper settings.....	145
System board jumpers and connectors.....	146
Disabling a forgotten password.....	147
8 Troubleshooting your system.....	149
Troubleshooting system startup failure.....	149
Troubleshooting external connections.....	149
Troubleshooting the video subsystem.....	150
Troubleshooting a USB device.....	150
Troubleshooting iDRAC Direct (USB XML configuration).....	151
Troubleshooting iDRAC Direct (Laptop connection).....	151
Troubleshooting a serial I/O device.....	152
Troubleshooting a NIC.....	152
Troubleshooting a wet system.....	152
Troubleshooting a damaged system.....	153
Troubleshooting the system battery.....	154
Troubleshooting power supply units.....	154
Troubleshooting power source problems.....	155
Troubleshooting power supply unit problems.....	155
Troubleshooting cooling problems.....	155
Troubleshooting cooling fans.....	156
Troubleshooting system memory.....	156
Troubleshooting an internal USB key.....	157
Troubleshooting an SD card.....	158
Troubleshooting an optical drive.....	158
Troubleshooting a tape backup unit.....	159

Troubleshooting a hard drive.....	159
Troubleshooting a storage controller.....	160
Troubleshooting expansion cards.....	161
Troubleshooting processors.....	162
System messages.....	162
Warning messages.....	162
Diagnostic messages.....	162
Alert messages.....	162
9 Getting help.....	163
Contacting Dell.....	163
Documentation feedback.....	163

Dell DR4300 system overview

Your Dell DR4300 system is 2U rack server that supports up to two Intel Xeon E5-2660 v3 processors, up to 24 DIMMs, and twelve 3.5-inch hard drives and 2 optional 2.5-inch back-accessible hard drives for the operating system.

Topics:

- [Front panel features and indicators](#)
- [Back panel features](#)
- [Diagnostic indicators on the front panel](#)
- [Documentation matrix](#)

Front panel features and indicators

The front panel provides access to the features available on the front of the server, such as the power button, NMI button, system identification tag, system identification button, and USB and VGA ports. The diagnostic LEDs or the LCD panel is prominently on the front panel. The hot swappable hard drives are accessible from the front panel.

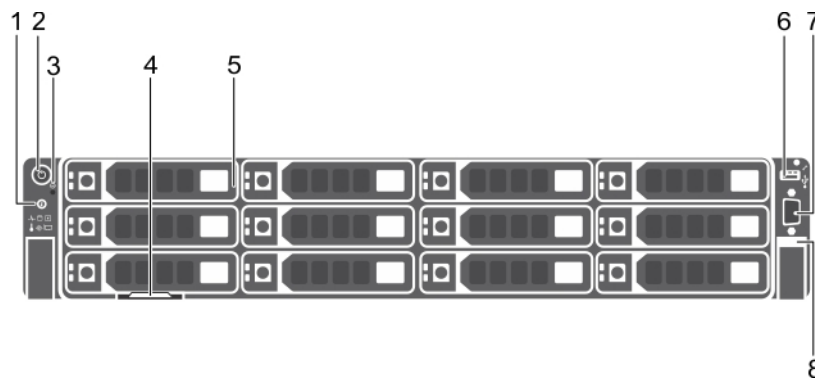





Figure 1. Dell DR4300 system front panel features and indicators

- | | |
|---------------------------------|-------------------------------------|
| 1. System identification button | 2. Power button |
| 3. NMI button | 4. Information tag |
| 5. Hard drives | 6. USB management port/iDRAC Direct |
| 7. Video connector | 8. Quick Sync |

Table 1. Front panel features and indicators

Item	Indicator, Button, or Connector	Icon	Description
1	System identification button		<p>Enables you to locate a particular system within a rack. The identification buttons are on the front and back panels.</p> <p>Press the system identification button to turn the system ID on or off.</p> <p>NOTE:</p> <ul style="list-style-type: none"> • If the system stops responding during POST, press and hold the system ID button (for more than five seconds) to enter BIOS progress mode. • To reset the iDRAC (if not disabled in F2 iDRAC set up) press and hold the button (for more than 15 seconds).

Item	Indicator, Button, or Connector	Icon	Description
2	Power button		Enables you to know the power status of the system. The power indicator turns on when the system power is on. The power button controls the power supply output to the system. NOTE: On ACPI-compliant operating systems, when the power button is used to shut down the system, the operating system performs a graceful shut down the system power is turned off.
3	NMI button		Enables you to troubleshoot software and device driver errors when running certain operating systems. This button can be pressed by using the end of a paper clip. NOTE: Use this button only if directed to do so by qualified support personnel or by instructions in the operating system's documentation.
4	Information tag		Contains system information such as service tag, NIC, MAC address for your reference. The information tag is a slide-out label panel.
5	Hard drives		Up to twelve 3.5-inch hot-swappable hard drives.
6	USB management port/iDRAC Direct		The USB management port is USB 2.0 compliant. Enables you to connect USB devices to the system or provides access to the iDRAC Direct features. For more information, see the Integrated Dell Remote Access Controller User's Guide at Dell.com/idracmanuals .
7	Video connector		Enables you to connect a display to the system.
8	Quick Sync (optional)		Indicates a Quick Sync enabled system. The Quick Sync feature is optional and needs a Quick Sync bezel. This feature allows management of the system by using mobile devices. This feature aggregates hardware or firmware inventory and various system level diagnostic and error information that can be used in troubleshooting the system. For more information, see the Integrated Dell Remote Access Controller User's Guide at Dell.com/idracmanuals .

Back panel features

The back panel provides access to the features available on the back of the server, such as the system identification button, power supply sockets, cable management arm connectors, iDRAC storage media, NIC ports, USB and VGA ports. Most of the expansion card ports can be accessed from the back panel. The hot swappable power supply units, and if installed, the rear accessible hard drives are accessible from the back panel.

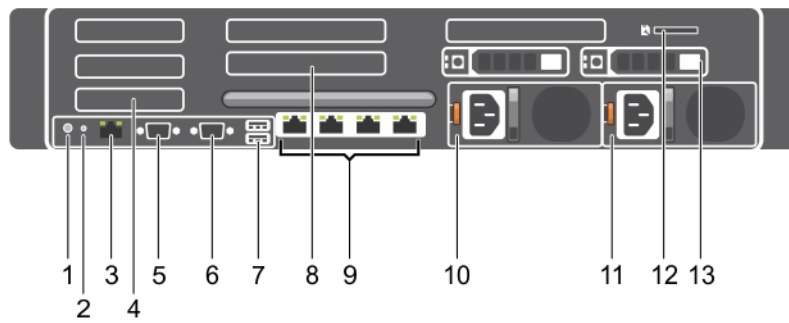



Figure 2. Back panel features

- | | |
|--|---|
| <ol style="list-style-type: none"> 1. System identification button 3. iDRAC8 Enterprise port 5. Serial connector 7. USB port 9. Ethernet connector 11. Power supply unit 2 13. Hard drive | <ol style="list-style-type: none"> 2. System identification connector 4. Half-height PCIe expansion card slot 6. Video connector 8. Full-height PCIe expansion card slot 10. Power supply unit 1 12. vFlash media card slot |
|--|---|

Table 2. Back panel features

Item	Indicator, button, or connector	Icon	Description
1	System identification button		<p>The identification buttons on the front and back panels can be used to locate a particular system within a rack.</p> <p>Press to toggle the system identification (ID) on or off.</p> <p>If the system stops responding during POST, press and hold the system ID button for more than five seconds to enter BIOS progress mode.</p> <p>To reset iDRAC (if not disabled in F2 iDRAC set up) press and hold the button for more than 15 seconds.</p>
2	System identification connector		Connects the optional system status indicator assembly through the optional cable management arm.
3	iDRAC8 Enterprise port		Dedicated management port.
4	Half-height PCIe expansion card slot (3)		Enables you to connect up to 3 half-height PCI Express expansion cards.
5	Serial connector		Enables you to connect a serial device to the system.
6	Video connector		Enables you to connect a VGA display to the system.
7	USB port (2)		Enables you to connect USB devices to the system. The ports are USB 3.0-compliant.
8	Full-height PCIe expansion card slot (3)		Enables you to connect up to 3 full-height PCI Express expansion cards.
9	Ethernet connector (4)		<p>Four integrated 10/100/1000 Mbps Network Interface Card (NIC) connectors</p> <p>or</p> <p>Four integrated connectors that include:</p> <ul style="list-style-type: none"> • Two 10/100/1000 Mbps NIC connectors





Item	Indicator, button, or connector	Icon	Description
			<ul style="list-style-type: none"> Two 100 Mbps/1 Gbps/10 Gbps SFP+/10 GbE T connectors
10	Power supply unit (PSU1)		1100 W
11	Power supply unit (PSU2)		1100 W

Diagnostic indicators on the front panel

 **NOTE:** The diagnostic indicators are not present if the system is equipped with an LCD display.

 **NOTE:** No diagnostic indicators are lit when the system is turned off. To start the system, plug it into a working power source and press the power button.

Table 3. Diagnostic indicators

Icon	Description	Condition	Corrective action
	Health indicator	<p>The indicator turns solid blue if the system is in good health.</p> <p>The indicator flashes amber:</p> <ul style="list-style-type: none"> When the system is turned on. When the system is in standby. If any error condition exists. For example, a failed fan, PSU, or a hard drive. 	<p>None required.</p> <p>Check the System Event Log or system messages for the specific issue. For more information about error messages, see the <i>Dell Event and Error Messages Reference Guide</i> at Dell.com/openmanagemanuals > OpenManage software.</p> <p>The POST process is interrupted without any video output due to invalid memory configurations. See the Getting help section.</p>
	Hard drive indicator	The indicator flashes amber if there is a hard drive error.	Check the System Event Log to determine the hard drive that has an error. Run the appropriate Online Diagnostics test. Restart the system and run embedded diagnostics (ePSA). If the hard drives are configured in a RAID array, restart the system and enter the host adapter configuration utility program.
	Electrical indicator	The indicator flashes amber if the system experiences an electrical error (for example, voltage out of range, or a failed power supply unit (PSU) or voltage regulator).	Check the System Event Log or system messages for the specific issue. If it is due to a problem with the PSU, check the LED on the PSU. Reseat the PSU. If the problem persists, see the Getting help section.
	Temperature indicator	The indicator flashes amber if the system experiences a thermal error (for example, the ambient temperature is out of range or fan failure).	<p>Ensure that none of the following conditions exist:</p> <ul style="list-style-type: none"> A cooling fan has been removed or has failed. System cover, cooling shroud, EMI filler panel, memory module blank, or back filler bracket is removed. Ambient temperature is too high. External airflow is obstructed. <p>See the Getting help section.</p>
	Memory indicator	The indicator flashes amber if a memory error occurs.	Check the system event log or system messages for the location of the failed memory. Reseat the memory module. If the problem persists, see the Getting help section.

Related reference

[Getting help](#)

Hard drive indicator codes

Each hard drive carrier has an activity indicator and a status indicator. The indicators provide information about the current status of the hard drive. The activity LED indicates whether hard drive is currently in use or not. The status LED indicates the power condition of the hard drive.

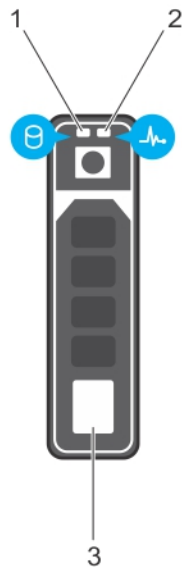

Figure 3. Hard drive indicators

1. hard drive activity indicator
2. hard drive status indicator
3. hard drive

NOTE: If the hard drive is in the Advanced Host Controller Interface (AHCI) mode, the status indicator (on the right side) does not turn on.

Table 4. Hard drive indicator codes

Drive-status indicator pattern (RAID only)	Condition
Flashes green twice per second	Identifying drive or preparing for removal.
Off	Drive ready for insertion or removal. NOTE: The drive status indicator remains off until all hard drives are initialized after the system is turned on. Drives are not ready for insertion or removal during this time.
Flashes green, amber, and then turns off	Predicted drive failure
Flashes amber four times per second	Drive failed
Flashes green slowly	Drive rebuilding
Steady green	Drive online
Flashes green for three seconds, amber for three seconds, and then turns off after six seconds	Rebuild stopped

NIC indicator codes

Each NIC on the back panel has an indicator that provides information about the network activity and link status. The activity LED indicates whether the NIC is currently connected or not. The link LED indicates the speed of the connected network.

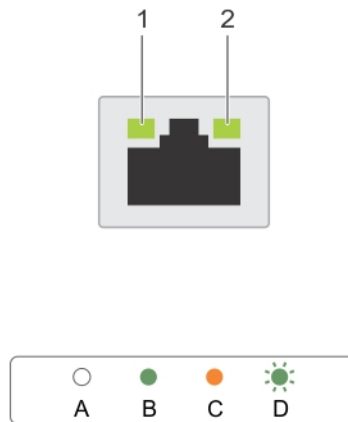

Figure 4. NIC indicators

1. link indicator
2. activity indicator

Table 5. NIC indicators

Convention	Status	Condition
A	Link and activity indicators are off	The NIC is not connected to the network.
B	Link indicator is green	The NIC is connected to a valid network at its maximum port speed (1 Gbps or 10 Gbps).
C	Link indicator is amber	The NIC is connected to a valid network at less than its maximum port speed.
D	Activity indicator is flashing green	Network data is being sent or received.

Power supply unit indicator codes

AC power supply units (PSUs) have an illuminated translucent handle that serves as an indicator and DC PSUs have an LED that serves as an indicator. The indicator shows whether power is present or a power fault has occurred.



Figure 5. AC PSU status indicator

1. AC PSU status indicator/handle

Table 6. AC PSU status indicators

Convention	Power indicator pattern	Condition
A	Green	A valid power source is connected to the PSU and the PSU is operational.
B	Flashing green	When the firmware of the PSU is being updated, the PSU handle flashes green.
C	Flashing green and turns off	When hot-adding a PSU, the PSU handle flashes green five times at 4 Hz rate and turns off. This indicates a PSU mismatch with respect to efficiency, feature set, health status, and supported voltage. NOTE: Ensure that both the PSUs are of the same capacity. CAUTION: For AC PSUs, use only PSUs with the Extended Power Performance (EPP) label on the back. NOTE: Mixing PSUs from previous generations of Dell PowerEdge servers can result in a PSU mismatch condition or failure to turn the system on.
D	Flashing amber	Indicates a problem with the PSU. CAUTION: When correcting a PSU mismatch, replace only the PSU with the flashing indicator. Swapping the PSU to make a matched pair can result in an error condition and unexpected system shutdown. To change from a high output configuration to a low output configuration or vice versa, you must turn off the system. CAUTION: AC PSUs support both 220 V and 110 V input voltages with the exception of Titanium PSUs, which support only 220 V. When two identical PSUs receive different input voltages, they can output different wattages, and trigger a mismatch. CAUTION: If two PSUs are used, they must be of the same type and have the same maximum output power. CAUTION: Combining AC and DC PSUs is not supported and triggers a mismatch.
E	Not lit	Power is not connected.

iDRAC Direct LED indicator codes

The iDRAC Direct LED indicator lights up to indicate that the port is connected and is being used as a part of the iDRAC subsystem.

NOTE: The iDRAC Direct LED indicator does not turn on when the USB port is used in the USB mode.



1. iDRAC Direct status indicator

The iDRAC Direct LED indicator table describes iDRAC Direct activity when configuring iDRAC Direct by using the management port (USB XML Import).

Table 7. iDRAC Direct LED indicators

Convention	iDRAC Direct LED indicator pattern	Condition
A	Green	Turns green for a minimum of two seconds to indicate the start and end of a file transfer.
B	Flashing green	Indicates file transfer or any operation tasks.
C	Green and turns off	Indicates that the file transfer is complete.
D	Not lit	Indicates that the USB is ready to be removed or that a task is complete.

The following table describes iDRAC Direct activity when configuring iDRAC Direct by using your laptop and cable (Laptop Connect):

Table 8. iDRAC Direct LED indicator patterns

iDRAC Direct LED indicator pattern	Condition
Solid green for two seconds	Indicates that the laptop is connected.
Flashing green (on for two seconds and off for two seconds)	Indicates that the laptop connected is recognized.
Turns off	Indicates that the laptop is unplugged.

Quick Sync indicator codes

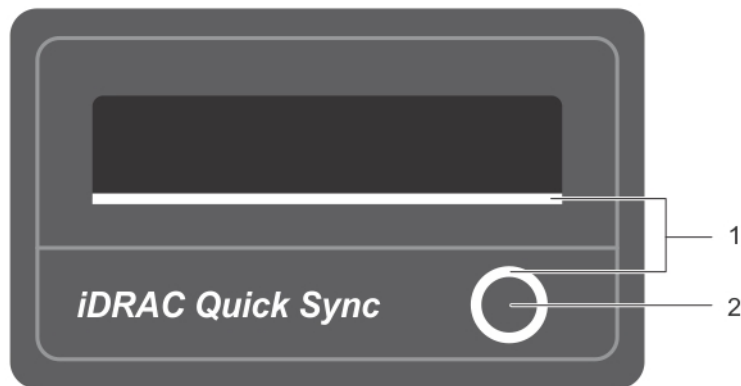

Figure 6. Quick Sync

1. Quick Sync Status Indicator
2. Quick Sync Activation Button

Table 9. Quick Sync indicator codes

Quick Sync indicator pattern	Condition
Slow blink	Quick Sync is waiting to be configured from iDRAC.
Solid	Quick Sync is ready to transfer.
Blinks three times rapidly and then turns off	Quick Sync feature is disabled from iDRAC.
Blinks continuously when the mobile device touches antenna	Indicates data transfer activity.
Blinks rapidly continuously when the activation button is pressed	Quick Sync hardware is not responding properly.
Turns off	Indicates that the Quick Sync feature is turned off. Use the activation button to activate it. If pressing the activation button does not turn on the LEDs, it indicates that power is not delivered to the Quick Sync bezel.

Locating Service Tag of your system

Your system is identified by a unique Express Service Code and Service Tag number. The Express Service Code and Service Tag are found on the front of the system by pulling out the information tag. Alternatively, the information may be on a sticker on the chassis of the system. This information is used by Dell to route support calls to the appropriate personnel.

Documentation matrix

The documentation matrix describes documents for setting up and managing your system.

Table 10. Documentation matrix

To...	Refer to...
Install your system into a rack	Rack documentation included with your rack solution.
Set up your system and know the system technical specifications	<i>Getting Started With Your System</i> that shipped with your system or see Dell.com/support/home

To...	Refer to...
Set up your Dell DR Series system	<i>Setting up your Dell DR4300 system</i> that shipped with your system or see Dell.com/support/home
Troubleshoot the system and install or replace system components	<i>Dell DR4300 System Owner's Manual</i> at Dell.com/support/home
Manage DR Series system data backup and replication operations	<i>Dell DR Series System Command Line Reference Guide</i> at Dell.com/support/home
Know the latest information about new features and known issues with a specific product release.	<i>Dell DR Series System Release Notes</i> at Dell.com/support/home
Gather information about supported hardware and software versions for the Dell DR Series system.	<i>Dell DR Series System Interoperability Guide</i> at Dell.com/support/home
Deploy the virtual DR2000v system on supported virtual platforms.	<i>Dell DR2000v Deployment Guide</i> at Dell.com/support/home
Configure, manage, update, and restore the system	<i>Dell DR Series System Administrator Guide</i> at Dell.com/support/home
Install the operating system	Operating system documentation at Dell.com/operatingsystemmanuals
Get an overview of the Dell Systems Management offerings	<i>Dell OpenManage Systems Management Overview Guide</i> at Dell.com/openmanagemanuals
Configure and log in to iDRAC, set up managed and management system, know the iDRAC features and troubleshoot using iDRAC	<i>Integrated Dell Remote Access Controller User's Guide</i> at Dell.com/esmanuals
Know about the RACADM subcommands and supported RACADM interfaces	<i>RACADM Command Line Reference Guide</i> for iDRAC and CMC at Dell.com/esmanuals
Launch, enable and disable Lifecycle Controller, know the features, use and troubleshoot Lifecycle Controller	<i>Dell Lifecycle Controller User's Guide</i> at Dell.com/esmanuals
Use Lifecycle Controller Remote Services	<i>Dell Lifecycle Controller Remote Services Quick Start Guide</i> at Dell.com/esmanuals
Set up, use, and troubleshoot OpenManage Server Administrator	<i>Dell OpenManage Server Administrator User's Guide</i> at Dell.com/openmanagemanuals
Install, use, and troubleshoot OpenManage Essentials	<i>Dell OpenManage Essentials User's Guide</i> at Dell.com/openmanagemanuals
Know the features of the storage controller cards, deploy the cards, and manage the storage subsystem	Storage controller documentation at Dell.com/storagecontrollermanuals
Check the event and error messages generated by the system firmware and agents that monitor system components	<i>Dell Event and Error Messages Reference Guide</i> at Dell.com/esmanuals

Technical specifications

Chassis dimensions

This section describes the physical dimensions of the system.

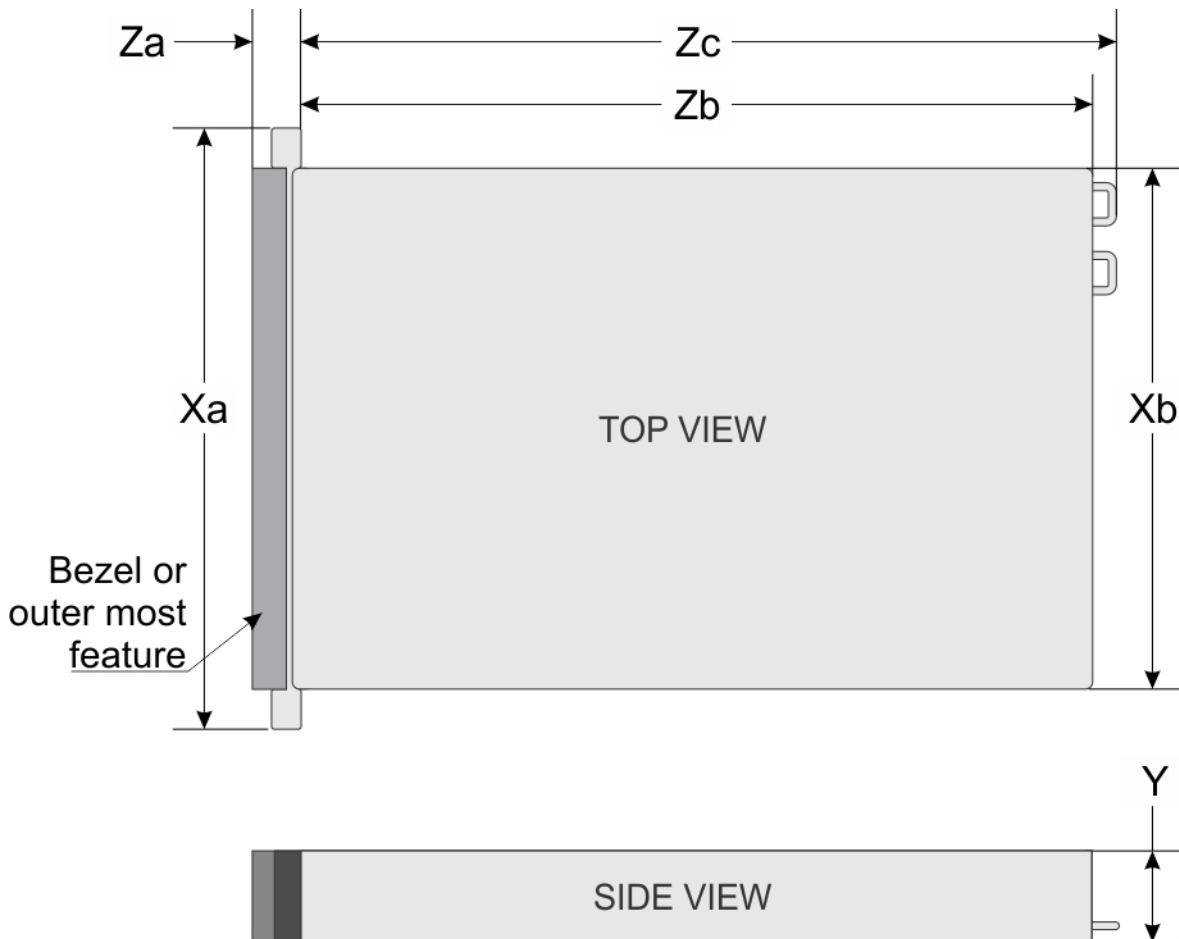

Figure 7. Chassis dimensions of your Dell DR4300 system

Table 11. Dimensions of your system

Xa	Xb	Y	Za (with bezel)	Za (without bezel)	Zb	Zc
482.4 mm	444.0 mm	87.3 mm	32.0 mm	18.0 mm	684.0 mm	723.0 mm

Chassis weight

This section describes the weight of the system.

Table 12. Chassis weight

System	Maximum weight (with all hard drives/SSDs)
Dell DR4300 system	36.5 kg (80.47 lb) (3.5-inch hard drive systems)

Processor specifications

Your Dell DR4300 system supports up to two Intel Xeon E5-2660 v3 processors.

PSU specifications

Your Dell DR4300 system supports up to two AC redundant power supply units (PSUs).

Table 13. PSU specifications

PSU	Class	Heat dissipation (maximum)	Frequency	Voltage
1100 W AC	Platinum	4100 BTU/hr	50/60 Hz	100–240 V AC, autoranging

NOTE: Heat dissipation is calculated using the PSU wattage rating.

NOTE: This system is also designed to connect to the IT power systems with a phase to phase voltage not exceeding 230 V.

System battery specifications

Your Dell DR4300 system supports CR 2032 3.0-V lithium coin cell system battery.

Expansion bus specifications

The Dell DR4300 system supports PCI express (PCIe) generation 3 expansion cards, which need to be installed on the system board using expansion card risers. This system supports three types of expansion card risers. The following table provides the expansion card riser specifications:

Table 14. Expansion card riser specifications

Expansion card riser	PCIe slots on the riser	Height	Length	Link
Riser 1	Slot 1	half-height	low-profile	x8
Riser 1	Slot 2	half-height	low-profile	x8
Riser 1	Slot 3	half-height	low-profile	x8
Riser 2	Slot 4	full-height	full-length	x16
Riser 2	Slot 5	full-height	full-length	x8
Riser 3 (alternate)	Slot 6	full-height	full-length	x16

NOTE: When using slots 1 through 4 on the riser, ensure that both the processors are installed on the system.

Memory specifications

The Dell DR4300 system supports DDR4 registered DIMMs (RDIMMs). Supported memory bus frequencies are 1333MT/s, 1600 MT/s, 1866 MT/s, 2133MT/s, or 2400 MT/s.

Table 15. Memory specifications

Memory module sockets	Memory capacity	Minimum RAM	Maximum RAM
Twenty-four 288-pin	4 GB single-ranked or 8 GB dual-ranked RDIMMs	<ul style="list-style-type: none">4 GB with single processor8 GB with dual processors (minimum one memory module per processor)	64 GB with two processors

Drive specifications

Hard drives

The Dell DR4300 system supports up to twelve 3.5-inch hard drives and two optional 2.5-inch back-accessible SAS, SATA, or Nearline SAS hard drives.

Ports and connectors specifications

USB ports

The Dell DR4300 system supports:

- USB 2.0-compliant ports on the front panel
- USB 3.0-complaint ports on the back panel
- internal USB 3.0-compliant port

The following table provides more information about the USB specifications:

Table 16. USB specifications

System	Front panel	Back panel	Internal
Dell DR4300 system	One USB management port/ iDRAC Direct	Two 9-pin, USB 3.0-compliant ports	One 9-pin, USB 3.0-compliant port

NIC ports

The Dell DR4300 system supports four Network Interface Controller (NIC) ports on the back panel, which is available in one of the following three NIC configurations:

- Four 1 Gbps
- Two 1 Gbps and two 10 Gbps
- Four 10 Gbps

Serial connector

The serial connector connects a serial device to the system. The Dell DR4300 system supports one serial connector on the back panel, which is a 9-pin connector, Data Terminal Equipment (DTE), 16550-compliant.

VGA ports

The Video Graphic Array (VGA) port enables you to connect the system to a VGA display. The Dell DR4300 system supports two 15-pin VGA ports on the front and back panels.

Internal Dual SD Module

The Dell DR4300 system supports two optional flash memory card slots with an internal dual SD module.

 **NOTE: One card slot is dedicated for redundancy.**

Video specifications

The Dell DR4300 system supports Matrox G200eR2 graphics card with 16 MB capacity.

Environmental specifications

NOTE: For additional information about environmental measurements for specific system configurations, see [Dell.com/environmental_datasheets](https://www.dell.com/environmental_datasheets).

Table 17. Temperature specifications

Temperature	Specifications
Storage	–40°C to 65°C (–40°F to 149°F)
Continuous operation (for altitude less than 950 m or 3117 ft)	10°C to 35°C (50°F to 95°F) with no direct sunlight on the equipment.
Fresh air	For information about fresh air, see Expanded Operating Temperature section.
Maximum temperature gradient (operating and storage)	20°C/h (68°F/h)

Table 18. Relative humidity specifications

Relative humidity	Specifications
Storage	5% to 95% RH with 33°C (91°F) maximum dew point. Atmosphere must be non-condensing at all times.
Operating	10% to 80% relative humidity with 29°C (84.2°F) maximum dew point.

Table 19. Maximum vibration specifications

Maximum vibration	Specifications
Operating	0.26 G _{rms} at 5 Hz to 350 Hz (all operation orientations).
Storage	1.88 G _{rms} at 10 Hz to 500 Hz for 15 min (all six sides tested).

Table 20. Maximum shock specifications

Maximum vibration	Specifications
Operating	Six consecutively executed shock pulses in the positive and negative x, y, and z axes of 40 G for up to 2.3 ms.
Storage	Six consecutively executed shock pulses in the positive and negative x, y, and z axes (one pulse on each side of the system) of 71 G for up to 2 ms.

Table 21. Maximum altitude specifications

Maximum altitude	Specifications
Operating	30482000 m (10,0006560 ft)
Storage	12,000 m (39,370 ft)

Table 22. Operating temperature de-rating specifications

Operating temperature de-rating	Specifications
Up to 35°C (95°F)	Maximum temperature is reduced by 1°C/300 m (1°F/547 ft) above 950 m (3,117 ft).
35°C to 40°C (95°F to 104°F)	Maximum temperature is reduced by 1°C/175 m (1°F/319 ft) above 950 m (3,117 ft).
40°C to 45°C (104°F to 113°F)	Maximum temperature is reduced by 1°C/125 m (1°F/228 ft) above 950 m (3,117 ft).

Particulate and gaseous contamination specifications

The following table defines the limitations that help avoid any equipment damage or failure from particulates and gaseous contamination. If the levels of particulates or gaseous pollution exceed the specified limitations and result in equipment damage or failure, you may need to rectify the environmental conditions. Re-mediation of environmental conditions is the responsibility of the customer.

Table 23. Particulate contamination specifications

Particulate contamination	Specifications
Air filtration	Data center air filtration as defined by ISO Class 8 per ISO 14644-1 with a 95% upper confidence limit. i NOTE: This condition applies to data center environments only. Air filtration requirements do not apply to IT equipment designed to be used outside a data center, in environments such as an office or factory floor. i NOTE: Air entering the data center must have MERV11 or MERV13 filtration.
Conductive dust	Air must be free of conductive dust, zinc whiskers, or other conductive particles. i NOTE: This condition applies to data center and non-data center environments.
Corrosive dust	<ul style="list-style-type: none"> Air must be free of corrosive dust. Residual dust present in the air must have a deliquescent point less than 60% relative humidity. i NOTE: This condition applies to data center and non-data center environments.

Table 24. Gaseous contamination specifications

Gaseous contamination	Specifications
Copper coupon corrosion rate	<300 Å/month per Class G1 as defined by ANSI/ISA71.04-1985.
Silver coupon corrosion rate	<200 Å/month as defined by AHSRAE TC9.9.

i **NOTE: Maximum corrosive contaminant levels measured at ≤50% relative humidity.**

Standard operating temperature

Table 25. Standard operating temperature specifications

Standard operating temperature	Specifications
Continuous operation (for altitude less than 950 m or 3117 ft)	10°C to 35°C (50°F to 95°F) with no direct sunlight on the equipment.

Expanded operating temperature

Table 26. Expanded operating temperature specifications

Expanded operating temperature	Specifications
Continuous operation	5°C to 40°C at 5% to 85% RH with 29°C dew point. i NOTE: Outside the standard operating temperature (10°C to 35°C), the system can operate continuously in temperatures as low as 5°C and as high as 40°C.

Expanded operating temperature

Specifications

≤ 1% of annual operating hours

For temperatures between 35°C and 40°C, de-rate maximum allowable temperature by 1°C per 175 m above 950 m (1°F per 319 ft).

–5°C to 45°C at 5% to 90% RH with 29°C dew point.

NOTE: Outside the standard operating temperature (10°C to 35°C), the system can operate down to –5°C or up to 45°C for a maximum of 1% of its annual operating hours.

For temperatures between 40°C and 45°C, de-rate maximum allowable temperature by 1°C per 125 m above 950 m (1°F per 228 ft).

NOTE: When operating in the expanded temperature range, system performance may be impacted.

NOTE: When operating in the expanded temperature range, ambient temperature warnings maybe reported on the LCD panel and in the System Event Log.

Expanded operating temperature restrictions

- Do not perform a cold startup below 5°C.
- The operating temperature specified is for a maximum altitude of 3050 m (10,000 ft).
- 160 W or higher wattage processor is not supported.
- Redundant power supply units are required.
- Non-Dell qualified peripheral cards and/or peripheral cards greater than 25 W are not supported.
- The 3.5-inch hard drive chassis supports a maximum of 120 W processor.
- The 2.5-inch hard drive chassis supports a maximum of 145 W processor.
- Only SSDs are allowed in the hard drive slots at the back of the 3.5-inch hard drive chassis.
- Mid drive configurations, eight 3.5-inch and eighteen 1.8-inch SSD configurations are not supported.
- GPU is not supported
- Tape backup unit (TBU) is not supported.

Initial system setup and configuration

Setting up your system

Complete the following steps to set up your system:

Steps

1. Unpack the system.
2. Install the system into the rack. For more information about installing the system into the rack, see your system *Rack Installation Placemat* at [Dell.com/poweredgemanuals](https://www.dell.com/poweredgemanuals).
3. Connect the peripherals to the system.
4. Connect the system to its electrical outlet.
5. Turn the system on by pressing the power button or by using iDRAC.
6. Turn on the attached peripherals.

iDRAC configuration

The Integrated Dell Remote Access Controller (iDRAC) is designed to make system administrators more productive and improve the overall availability of Dell systems. iDRAC alerts administrators to system issues, helps them perform remote system management, and reduces the need for physical access to the system.

Options to set up iDRAC IP address

You must configure the initial network settings based on your network infrastructure to enable the communication to and from iDRAC. You can set up the IP address by using one of the following interfaces:

Interfaces	Document/Section
iDRAC Settings utility	See <i>Dell Integrated Dell Remote Access Controller User's Guide</i> at Dell.com/idracmanuals
Dell Deployment Toolkit	See <i>Dell Deployment Toolkit User's Guide</i> at Dell.com/openmanagemanuals
Dell Lifecycle Controller	See <i>Dell Lifecycle Controller User's Guide</i> at Dell.com/idracmanuals
Chassis or Server LCD panel	See the LCD panel section

You must use the default iDRAC IP address 192.168.0.120 to configure the initial network settings, including setting up DHCP or a static IP for iDRAC.

NOTE: To access iDRAC, ensure that you install the iDRAC port card or connect the network cable to the Ethernet connector 1 on the system board.

NOTE: Ensure that you change the default user name and password after setting up the iDRAC IP address.

Log in to iDRAC

You can log in to iDRAC as:

- iDRAC user
- Microsoft Active Directory user
- Lightweight Directory Access Protocol (LDAP) user

The default user name and password are `root` and `calvin`. You can also log in by using Single Sign-On or Smart Card.

NOTE: You must have iDRAC credentials to log in to iDRAC.

For more information about logging in to iDRAC and iDRAC licenses, see the *Integrated Dell Remote Access Controller User's Guide* at Dell.com/idracmanuals.

Options to install the operating system

If the system is shipped without an operating system, install the supported operating system by using one of the following resources:

Table 27. Resources to install the operating system

Resources	Location
Dell Systems Management Tools and Documentation media	Dell.com/operatingsystemmanuals
Dell Lifecycle Controller	Dell.com/idracmanuals
Dell OpenManage Deployment Toolkit	Dell.com/openmanagemanuals
Dell certified VMware ESXi	Dell.com/virtualizationsolutions
Supported operating systems on Dell PowerEdge systems	Dell.com/ossupport
Installation and How-to videos for supported operating systems on Dell PowerEdge systems	Supported Operating Systems for Dell PowerEdge Systems

Methods to download firmware and drivers

You can download the firmware and drivers by using any of the following methods:

Table 28. Firmware and drivers

Methods	Location
From the Dell Support site	Dell.com/support/home
Using Dell Remote Access Controller Lifecycle Controller (iDRAC with LC)	Dell.com/idracmanuals
Using Dell Repository Manager (DRM)	Dell.com/openmanagemanuals
Using Dell OpenManage Essentials (OME)	Dell.com/openmanagemanuals
Using Dell Server Update Utility (SUU)	Dell.com/openmanagemanuals
Using Dell OpenManage Deployment Toolkit (DTK)	Dell.com/openmanagemanuals

Downloading the drivers and firmware

Dell recommends that you download and install the latest BIOS, drivers, and systems management firmware on your system.

Prerequisites

Ensure that you clear the web browser cache before downloading the drivers and firmware.

Steps

1. Go to Dell.com/support/drivers.
2. Under the **Drivers & Downloads** section, type the Service Tag of your system in the **Service Tag or Express Service Code** box.

NOTE: If you do not have the Service Tag, select **Detect My Product** to allow the system to automatically detect your Service Tag, or under **General support**, navigate to your product.

3. Click **Drivers & Downloads**.
The drivers that are applicable to your selection are displayed.
4. Download the drivers you need to a USB drive, CD, or DVD.

Manage your system

This section provides the information about server management software.

Server Management Software	Description
OpenManage	<p>The Dell OpenManage Server Administrator provides a comprehensive one-to-one systems management solution for both local and remote servers and their storage controllers and Direct Attached Storage (DAS).</p> <p>For information about OpenManage documents, see Dell.com/openmanagemanuals.</p>
OpenManage Essentials	<p>Dell OpenManage Essentials is the newest one-to-many management console for managing Dell PowerEdge servers and direct-attached storage as it provides a simple and easy interface for system administrators to maximize the uptime and health of Dell systems.</p> <p>For information about OpenManage documents, see Dell.com/openmanagemanuals.</p>
Remote Access Controller with Dell Lifecycle Controller (iDRAC with LC)	<p>iDRAC with Dell Lifecycle Controller allows administrators to deploy, update, monitor, and manage Dell servers from any location without the use of agents in a one-to-one or one-to-many method. This out-of-band management allows the updates to be sent from Dell or appropriate third-party consoles directly to iDRAC with Dell Lifecycle Controller on a Dell PowerEdge server, regardless of the operating system that may or may not be running.</p> <p>For information about Remote Enterprise Systems Management documents, see Dell.com/idracmanuals.</p>
Partner Programs Enterprise Systems Management	<p>For information about OpenManage Connections Enterprise Systems Management documents, see Dell.com/omconnectionsenterprisesystemsmanagement.</p>
OpenManage Connections Client Systems Management	<p>For information about OpenManage Connections Client Systems Management documents, see Dell.com/dellclientcommandsuite/manuals.</p>

Pre-operating system management applications

Options to manage the pre-operating system applications

Your system has the following options to manage the pre-operating system applications:

- System Setup
- Boot Manager
- Dell Lifecycle Controller
- Preboot Execution Environment (PXE)

Related concepts

[System Setup](#)

[Boot Manager](#)

[Dell Lifecycle Controller](#)

[PXE boot](#)

System Setup

By using the **System Setup** screen, you can configure the BIOS settings, iDRAC settings, and device settings of your system.

i **NOTE: Help text for the selected field is displayed in the graphical browser by default. To view the help text in the text browser, press F1.**

You can access system setup by using two methods:

- Standard graphical browser — The browser is enabled by default.
- Text browser — The browser is enabled by using Console Redirection.

Related tasks

[Viewing System Setup](#)

Related reference

[System Setup details](#)

Viewing System Setup

To view the **System Setup** screen, perform the following steps:

Steps

1. Turn on, or restart your system.
2. Press F2 immediately after you see the following message:

```
F2 = System Setup
```

i **NOTE: If your operating system begins to load before you press F2, wait for the system to finish booting, and then restart your system and try again.**

Related concepts

[System Setup](#)

Related reference

[System Setup details](#)

System Setup details

The **System Setup Main Menu** screen details are explained as follows:

Option	Description
System BIOS	Enables you to configure BIOS settings.
iDRAC Settings	Enables you to configure iDRAC settings. The iDRAC settings utility is an interface to set up and configure the iDRAC parameters by using UEFI (Unified Extensible Firmware Interface). You can enable or disable various iDRAC parameters by using the iDRAC settings utility. For more information about this utility, see <i>Integrated Dell Remote Access Controller User's Guide</i> at Dell.com/idracmanuals .
Device Settings	Enables you to configure device settings.

Related concepts

[System Setup](#)

Related tasks

[Viewing System Setup](#)

System BIOS

You can use the **System BIOS** screen to edit specific functions such as boot order, system password, setup password, set the RAID mode, and enable or disable USB ports.

Related concepts

[Secure Boot Custom Policy Settings](#)

Related tasks

[Viewing System BIOS](#)

Related reference

[System BIOS Settings details](#)

[Boot Settings](#)

[Network Settings](#)

[System Information](#)

[Memory Settings](#)

[Processor Settings](#)

[SATA Settings](#)

[Integrated Devices](#)

[Serial Communication](#)

[System Profile Settings](#)

[Miscellaneous Settings](#)

[iDRAC Settings utility](#)

[Device Settings](#)

Viewing System BIOS

To view the **System BIOS** screen, perform the following steps:

Steps

1. Turn on, or restart your system.
2. Press F2 immediately after you see the following message:

```
F2 = System Setup
```

NOTE: If your operating system begins to load before you press F2, wait for the system to finish booting, and then restart your system and try again.

3. On the **System Setup Main Menu** screen, click **System BIOS**.

Related reference

- [System BIOS](#)
- [System BIOS Settings details](#)

System BIOS Settings details

About this task

The **System BIOS Settings** screen details are explained as follows:

Option	Description
System Information	Specifies information about the system such as the system model name, BIOS version, and Service Tag.
Memory Settings	Specifies information and options related to the installed memory.
Processor Settings	Specifies information and options related to the processor such as speed and cache size.
SATA Settings	Specifies options to enable or disable the integrated SATA controller and ports.
Boot Settings	Specifies options to specify the boot mode (BIOS or UEFI). Enables you to modify UEFI and BIOS boot settings.
Network Settings	Specifies options to change the network settings.
Integrated Devices	Specifies options to manage integrated device controllers and ports and specify related features and options.
Serial Communication	Specifies options to manage the serial ports and specify related features and options.
System Profile Settings	Specifies options to change the processor power management settings, memory frequency, and so on.
System Security	Specifies options to configure the system security settings, such as system password, setup password, Trusted Platform Module (TPM) security. It also manages the power and NMI buttons on the system.
Miscellaneous Settings	Specifies options to change the system date, time, and so on.

Related tasks

- [Viewing System BIOS](#)

Related reference

- [System BIOS](#)

Boot Settings

You can use the **Boot Settings** screen to set the boot mode to either **BIOS** or **UEFI**. It also enables you to specify the boot order.

Related tasks

- [Boot Settings details](#)
- [Viewing Boot Settings](#)
- [Changing the boot order](#)

Related reference

- [System BIOS](#)
- [Choosing the system boot mode](#)

Viewing Boot Settings

To view the **Boot Settings** screen, perform the following steps:

Steps

1. Turn on, or restart your system.
2. Press F2 immediately after you see the following message:

```
F2 = System Setup
```

NOTE: If your operating system begins to load before you press F2, wait for the system to finish booting, and then restart your system and try again.

3. On the **System Setup Main Menu** screen, click **System BIOS**.
4. On the **System BIOS** screen, click **Boot Settings**.

Related tasks

- [Boot Settings details](#)
- [Changing the boot order](#)

Related reference



- [Boot Settings](#)
- [Choosing the system boot mode](#)

Boot Settings details

About this task

The **Boot Settings** screen details are explained as follows:

Option	Description
Boot Mode	<p>Enables you to set the boot mode of the system.</p> <p>CAUTION: Switching the boot mode may prevent the system from booting if the operating system is not installed in the same boot mode.</p> <p>If the operating system supports UEFI, you can set this option to UEFI. Setting this field to BIOS allows compatibility with non-UEFI operating systems. This option is set to BIOS by default.</p> <p>NOTE: Setting this field to UEFI disables the BIOS Boot Settings menu. Setting this field to BIOS disables the UEFI Boot Settings menu.</p>
Boot Sequence Retry	<p>Enables or disables the Boot Sequence Retry feature. If this option is set to Enabled and the system fails to boot, the system reattempts the boot sequence after 30 seconds. This option is set to Enabled by default.</p>
Hard-Disk Failover	<p>Specifies the hard drive that is booted in the event of a hard drive failure. The devices are selected in the Hard-Disk Drive Sequence on the Boot Option Setting menu. When this option is set to Disabled, only the first</p>

Option	Description
	hard drive in the list is attempted to boot. When this option is set to Enabled , all hard drives are attempted to boot in the order selected in the Hard-Disk Drive Sequence . This option is not enabled for UEFI Boot Mode.
Boot Option Settings	Configures the boot sequence and the boot devices.
BIOS Boot Settings	Enables or disables BIOS boot options.  NOTE: This option is enabled only if the boot mode is BIOS.
UEFI Boot Settings	Enables or disables UEFI Boot options. The Boot options include IPv4 PXE and IPv6 PXE . This option is set to IPv4 by default.  NOTE: This option is enabled only if the boot mode is UEFI.

Related tasks

[Viewing Boot Settings](#)

[Changing the boot order](#)

Related reference

[Boot Settings](#)

[Choosing the system boot mode](#)

Choosing the system boot mode

System Setup enables you to specify one of the following boot modes for installing your operating system:

- BIOS boot mode (the default) is the standard BIOS-level boot interface.
- Unified Extensible Firmware Interface (UEFI) boot mode is an enhanced 64-bit boot interface. If you have configured your system to boot to UEFI mode, it replaces the system BIOS.

1. From the **System Setup Main Menu**, click **Boot Settings**, and select **Boot Mode**.
2. Select the boot mode you want the system to boot into.

 **CAUTION: Switching the boot mode may prevent the system from booting if the operating system is not installed in the same boot mode.**

3. After the system boots in the specified boot mode, proceed to install your operating system from that mode.

 **NOTE: Operating systems must be UEFI-compatible to be installed from the UEFI boot mode. DOS and 32-bit operating systems do not support UEFI and can only be installed from the BIOS boot mode.**

 **NOTE: For the latest information about supported operating systems, go to Dell.com/ossupport.**

Related tasks

[Boot Settings details](#)

[Viewing Boot Settings](#)

Related reference

[Boot Settings](#)

Changing the boot order

You may have to change the boot order if you want to boot from a USB key. The following instructions may vary if you have selected **BIOS** for **Boot Mode**.

Steps

1. On the **System Setup Main Menu** screen, click **System BIOS > Boot Settings**.
2. Click **Boot Option Settings > Boot Sequence**.
3. Use the arrow keys to select a boot device, and use the plus (+) and minus (-) sign keys to move the device down or up in the order.
4. Click **Exit**, and then click **Yes** to save the settings on exit.

Related tasks

[Boot Settings details](#)
[Viewing Boot Settings](#)

Related reference

[Boot Settings](#)

Network Settings

You can use the **Network Settings** screen to modify PXE device settings. The network settings option is available only in the UEFI mode.

NOTE: The BIOS does not control network settings in the BIOS mode. For the BIOS boot mode, the optional Boot ROM of the network controllers handles the network settings.

Related concepts

[UEFI iSCSI Settings](#)

Related tasks

[Viewing Network Settings](#)
[Viewing UEFI iSCSI Settings](#)

Related reference

[Network Settings screen details](#)
[UEFI iSCSI Settings details](#)
[System BIOS](#)

Viewing Network Settings

To view the **Network Settings** screen, perform the following steps:

Steps

1. Turn on, or restart your system.
2. Press F2 immediately after you see the following message:

```
F2 = System Setup
```

NOTE: If your operating system begins to load before you press F2, wait for the system to finish booting, and then restart your system and try again.

3. On the **System Setup Main Menu** screen, click **System BIOS**.
4. On the **System BIOS** screen, click **Network Settings**.

Related reference

[Network Settings](#)
[Network Settings screen details](#)

Network Settings screen details

The **Network Settings** screen details are explained as follows:

About this task

Option	Description
PXE Device n (n = 1 to 4)	Enables or disables the device. When enabled, a UEFI boot option is created for the device.

Option	Description
PXE Device n Settings(n = 1 to 4)	Enables you to control the configuration of the PXE device.

Related tasks

[Viewing Network Settings](#)

Related reference

[Network Settings](#)

UEFI iSCSI Settings

You can use the iSCSI Settings screen to modify iSCSI device settings. The iSCSI Settings option is available only in the UEFI boot mode. BIOS does not control network settings in the BIOS boot mode. For the BIOS boot mode, the option ROM of the network controller handles the network settings.

Related tasks

[Viewing UEFI iSCSI Settings](#)

Related reference

[UEFI iSCSI Settings details](#)

[UEFI iSCSI Settings](#)

Viewing UEFI iSCSI Settings

To view the **UEFI iSCSI Settings** screen, perform the following steps:

Steps

1. Turn on, or restart your system.
2. Press F2 immediately after you see the following message:

```
F2 = System Setup
```

NOTE: If your operating system begins to load before you press F2, wait for the system to finish booting, and then restart your system and try again.

3. On the **System Setup Main Menu** screen, click **System BIOS**.
4. On the **System BIOS** screen, click **Network Settings**.
5. On the **Network Settings** screen, click **UEFI iSCSI Settings**.

Related reference

[UEFI iSCSI Settings](#)

UEFI iSCSI Settings details

The **UEFI iSCSI Settings** screen details are explained as follows:

Option	Description
iSCSI Initiator Name	Specifies the name of the iSCSI initiator (iqn format).
iSCSI Device n (n = 1 to 4)	Enables or disables the iSCSI device. When disabled, a UEFI boot option is created for the iSCSI device automatically.

System Security

You can use the **System Security** screen to perform specific functions such as setting the system password, setup password and disabling the power button.

Related concepts

[Secure Boot Custom Policy Settings](#)

Related tasks

[System Security Settings details](#)

[Viewing System Security](#)

[Creating a system and setup password](#)

[Using your system password to secure your system](#)

[Deleting or changing system and setup password](#)

Related reference

[Operating with a setup password enabled](#)

[System BIOS](#)

Viewing System Security

To view the **System Security** screen, perform the following steps:

Steps

1. Turn on, or restart your system.
2. Press F2 immediately after you see the following message:

```
F2 = System Setup
```

NOTE: If your operating system begins to load before you press F2, wait for the system to finish booting, and then restart your system and try again.

3. On the **System Setup Main Menu** screen, click **System BIOS**.
4. On the **System BIOS** screen, click **System Security**.

Related tasks

[System Security Settings details](#)

Related reference



[System Security](#)

System Security Settings details

About this task

The **System Security Settings** screen details are explained as follows:

Option	Description
Intel AES-NI	Improves the speed of applications by performing encryption and decryption by using the Advanced Encryption Standard Instruction Set (AES-NI). This option is set to Enabled by default.
System Password	Sets the system password. This option is set to Enabled by default and is read-only if the password jumper is not installed in the system.
Setup Password	Sets the setup password. This option is read-only if the password jumper is not installed in the system.
Password Status	Locks the system password. This option is set to Unlocked by default.

Option	Description
TPM Security	 NOTE: The TPM menu is available only when the TPM module is installed. Enables you to control the reporting mode of the TPM. The TPM Security option is set to Off by default. You can only modify the TPM Status, TPM Activation, and Intel TXT fields if the TPM Status field is set to either On with Pre-boot Measurements or On without Pre-boot Measurements .
TPM Information	Changes the operational state of the TPM. This option is set to No Change by default.
TPM Status	Specifies the TPM status.
TPM Command	 CAUTION: Clearing the TPM results in the loss of all keys in the TPM. The loss of TPM keys may affect booting to the operating system. Clears all the contents of the TPM. The TPM Clear option is set to No by default.
Intel TXT	Enables or disables the Intel Trusted Execution Technology (TXT) option. To enable the Intel TXT option, virtualization technology and TPM Security must be enabled with Pre-boot measurements. This option is set to Off by default.
Power Button	Enables or disables the power button on the front of the system. This option is set to Enabled by default.
NMI Button	Enables or disables the NMI button on the front of the system. This option is set to Disabled by default.
AC Power Recovery	Sets how the system behaves after AC power is restored to the system. This option is set to Last by default.
AC Power Recovery Delay	Sets the time delay for the system to power up after AC power is restored to the system. This option is set to Immediate by default.
User Defined Delay (60s to 240s)	Sets the User Defined Delay option when the User Defined option for AC Power Recovery Delay is selected.
UEFI Variable Access	Provides varying degrees of securing UEFI variables. When set to Standard (the default), UEFI variables are accessible in the operating system per the UEFI specification. When set to Controlled , selected UEFI variables are protected in the environment and new UEFI boot entries are forced to be at the end of the current boot order.
Secure Boot	Enables Secure Boot, where the BIOS authenticates each pre-boot image by using the certificates in the Secure Boot Policy. Secure Boot is disabled by default.
Secure Boot Policy	When Secure Boot policy is set to Standard , the BIOS uses the system manufacturer's key and certificates to authenticate pre-boot images. When Secure Boot policy is set to Custom , the BIOS uses the user-defined key and certificates. Secure Boot policy is set to Standard by default.
Secure Boot Policy Summary	Specifies the list of certificates and hashes that secure boot uses to authenticate images.

Related tasks

[Viewing System Security](#)

Related reference

[System Security](#)

Secure Boot Custom Policy Settings

Secure Boot Custom Policy Settings is displayed only when **Secure Boot Policy** is set to **Custom**.

Related tasks

[Viewing Secure Boot Custom Policy Settings](#)

Related reference

[Secure Boot Custom Policy Settings details](#)

Viewing Secure Boot Custom Policy Settings

To view the **Secure Boot Custom Policy Settings** screen, perform the following steps:

Steps

1. Turn on, or restart your system.
2. Press F2 immediately after you see the following message:

```
F2 = System Setup
```

NOTE: If your operating system begins to load before you press F2, wait for the system to finish booting, and then restart your system and try again.

3. On the **System Setup Main Menu** screen, click **System BIOS**.
4. On the **System BIOS** screen, click **System Security**.
5. On the **System Security** screen, click **Secure Boot Custom Policy Settings**.

Secure Boot Custom Policy Settings details

The **Secure Boot Custom Policy Settings** screen details are explained as follows:

Option	Description
Platform Key	Imports, exports, deletes, or restores the platform key (PK).
Key Exchange Key Database	Enables you to import, export, delete, or restore entries in the Key Exchange Key (KEK) Database.
Authorized Signature Database	Imports, exports, deletes, or restores entries in the Authorized Signature Database (db).
Forbidden Signature Database	Imports, exports, deletes, or restores entries in the Forbidden Signature Database (dbx).

Creating a system and setup password

Prerequisites

Ensure that the password jumper is enabled. The password jumper enables or disables the system password and setup password features. For more information, see the System board jumper settings section.

NOTE: If the password jumper setting is disabled, the existing system password and setup password are deleted and you need not provide the system password to boot the system.

Steps

1. To enter System Setup, press F2 immediately after turning on or rebooting your system.
2. On the **System Setup Main Menu** screen, click **System BIOS > System Security**.
3. On the **System Security** screen, verify that **Password Status** is set to **Unlocked**.
4. In the **System Password** field, type your system password, and press Enter or Tab.

Use the following guidelines to assign the system password:

- A password can have up to 32 characters.
- The password can contain the numbers 0 through 9.
- Only the following special characters are allowed: space, ("), (+), (,), (-), (.), (/), (:), ([], (\), (]), (').

A message prompts you to reenter the system password.

5. Reenter the system password, and click **OK**.
6. In the **Setup Password** field, type your setup password and press Enter or Tab. A message prompts you to reenter the setup password.
7. Reenter the setup password, and click **OK**.
8. Press Esc to return to the System BIOS screen. Press Esc again. A message prompts you to save the changes.

 **NOTE:** Password protection does not take effect until the system reboots.

Related reference

[System Security](#)

Using your system password to secure your system

If you have assigned a setup password, the system accepts your setup password as an alternate system password.

Steps

1. Turn on or reboot your system.
2. Type the system password and press Enter.

Next steps

When **Password Status** is set to **Locked**, type the system password and press Enter when prompted at reboot.

 **NOTE:** If an incorrect system password is typed, the system displays a message and prompts you to reenter your password. You have three attempts to type the correct password. After the third unsuccessful attempt, the system displays an error message that the system has stopped functioning and must be turned off. Even after you turn off and restart the system, the error message is displayed until the correct password is entered.

Related reference

[System Security](#)

Deleting or changing system and setup password

Prerequisites

 **NOTE:** You cannot delete or change an existing system or setup password if the **Password Status** is set to **Locked**.

Steps

1. To enter System Setup, press F2 immediately after turning on or restarting your system.
2. On the **System Setup Main Menu** screen, click **System BIOS > System Security**.
3. On the **System Security** screen, ensure that **Password Status** is set to **Unlocked**.
4. In the **System Password** field, alter or delete the existing system password, and then press Enter or Tab.
5. In the **Setup Password** field, alter or delete the existing setup password, and then press Enter or Tab.
If you change the system and setup password, a message prompts you to reenter the new password. If you delete the system and setup password, a message prompts you to confirm the deletion.
6. Press Esc to return to the **System BIOS** screen. Press Esc again, and a message prompts you to save the changes.

Related reference

[System Security](#)

Operating with a setup password enabled

If **Setup Password** is set to **Enabled**, type the correct setup password before modifying the system setup options.

If you do not type the correct password in three attempts, the system displays the following message:

```
Invalid Password! Number of unsuccessful password attempts: <x> System Halted! Must power down.
```

Even after you turn off and restart the system, the error message is displayed until the correct password is typed. The following options are exceptions:

- If **System Password** is not set to **Enabled** and is not locked through the **Password Status** option, you can assign a system password. For more information, see the System Security Settings screen section.

- You cannot disable or change an existing system password.

NOTE: You can use the password status option with the setup password option to protect the system password from unauthorized changes.

Related reference

[System Security](#)

System Information

You can use the **System Information** screen to view system properties such as Service Tag, system model name, and the BIOS version.

Related tasks

[Viewing System Information](#)

Related reference

[System Information details](#)

[System BIOS](#)

Viewing System Information

To view the **System Information** screen, perform the following steps:

Steps

1. Turn on, or restart your system.
2. Press F2 immediately after you see the following message:

```
F2 = System Setup
```

NOTE: If your operating system begins to load before you press F2, wait for the system to finish booting, and then restart your system and try again.

3. On the **System Setup Main Menu** screen, click **System BIOS**.
4. On the **System BIOS** screen, click **System Information**.

Related reference

[System Information](#)

System Information details

About this task

The **System Information** screen details are explained as follows:

Option	Description
System Model Name	Specifies the system model name.
System BIOS Version	Specifies the BIOS version installed on the system.
System Management Engine Version	Specifies the current version of the Management Engine firmware.
System Service Tag	Specifies the system Service Tag.
System Manufacturer	Specifies the name of the system manufacturer.

Option	Description
System Manufacturer Contact Information	Specifies the contact information of the system manufacturer.
System CPLD Version	Specifies the current version of the system complex programmable logic device (CPLD) firmware.
UEFI Compliance Version	Specifies the UEFI compliance level of the system firmware.

Related tasks

[Viewing System Information](#)

Related reference

[System Information](#)

[System Information details](#)

Memory Settings

You can use the **Memory Settings** screen to view all the memory settings and enable or disable specific memory functions, such as system memory testing and node interleaving.

Related tasks

[Viewing Memory Settings](#)

Related reference

[Memory Settings details](#)

[System BIOS](#)

Viewing Memory Settings

To view the **Memory Settings** screen, perform the following steps:

Steps

1. Turn on, or restart your system.
2. Press F2 immediately after you see the following message:

```
F2 = System Setup
```

NOTE: If your operating system begins to load before you press F2, wait for the system to finish booting, and then restart your system and try again.

3. On the **System Setup Main Menu** screen, click **System BIOS**.
4. On the **System BIOS** screen, click **Memory Settings**.

Related reference



[Memory Settings](#)

[Memory Settings details](#)

Memory Settings details

About this task

The **Memory Settings** screen details are explained as follows:

Option	Description
System Memory Size	Specifies the memory size in the system.
System Memory Type	Specifies the type of memory installed in the system.
System Memory Speed	Specifies the system memory speed.
System Memory Voltage	Specifies the system memory voltage.
Video Memory	Specifies the amount of video memory.
System Memory Testing	Specifies whether the system memory tests are run during system boot. Options are Enabled and Disabled . This option is set to Disabled by default.
Memory Operating Mode	<p>Specifies the memory operating mode. The options available are Optimizer Mode, Advanced ECC Mode, Mirror Mode, Spare Mode, Spare with Advanced ECC Mode, Dell Fault Resilient Mode and Dell NUMA Fault Resilient Mode. This option is set to Optimizer Mode by default.</p> <p> NOTE: The Memory Operating Mode option can have different default and available options based on the memory configuration of your system.</p> <p> NOTE: The Dell Fault Resilient Mode option establishes an area of memory that is fault resilient. This mode can be used by an operating system that supports the feature to load critical applications or enables the operating system kernel to maximize system availability.</p>
Node Interleaving	Specifies if Non-Uniform Memory architecture (NUMA) is supported. If this field is set to Enabled , memory interleaving is supported if a symmetric memory configuration is installed. If the field is set to Disabled , the system supports NUMA (asymmetric) memory configurations. This option is set to Disabled by default.
Snoop Mode	Specifies the Snoop Mode options. The Snoop Mode options available are Home Snoop , Early Snoop , and Cluster on Die . This option is set to Early Snoop by default. This field is available only when the Node Interleaving is set to Disabled .

Related tasks

[Viewing Memory Settings](#)

Related reference

[Memory Settings](#)

Processor Settings

You can use the **Processor Settings** screen to view the processor settings, and perform specific functions such as enabling virtualization technology, hardware prefetcher, and logical processor idling.

Related tasks

[Viewing Processor Settings](#)

Related reference

[Processor Settings details](#)
[System BIOS](#)

Viewing Processor Settings

To view the **Processor Settings** screen, perform the following steps:

Steps

1. Turn on, or restart your system.

2. Press F2 immediately after you see the following message:

F2 = System Setup

NOTE: If your operating system begins to load before you press F2, wait for the system to finish booting, and then restart your system and try again.

3. On the **System Setup Main Menu** screen, click **System BIOS**.
4. On the **System BIOS** screen, click **Processor Settings**.

Related reference

[Processor Settings](#)

[Processor Settings details](#)

Processor Settings details

About this task

The **Processor Settings** screen details are explained as follows:

Option	Description
Logical Processor	Enables or disables the logical processors and displays the number of logical processors. If this option is set to Enabled , the BIOS displays all the logical processors. If this option is set to Disabled , the BIOS displays only one logical processor per core. This option is set to Enabled by default.
QPI Speed	Enables you to control QuickPath Interconnect data rate settings.
Alternate RTID (Requestor Transaction ID) Setting	Modifies Requestor Transaction IDs, which are QPI resources. This option is set to Disabled by default. NOTE: Enabling this option may negatively impact the overall system performance.
Virtualization Technology	Enables or disables the additional hardware capabilities provided for virtualization. This option is set to Enabled by default.
Address Translation Service (ATS)	Defines the Address Translation Cache (ATC) for devices to cache the DMA transactions. This option provides an interface between CPU and DMA Memory Management to a chipset's Address Translation and Protection Table to translate DMA addresses to host addresses. This option is set to Enabled by default.
Adjacent Cache Line Prefetch	Optimizes the system for applications that need high utilization of sequential memory access. This option is set to Enabled by default. You can disable this option for applications that need high utilization of random memory access.
Hardware Prefetcher	Enables or disables the hardware prefetcher. This option is set to Enabled by default.
DCU Streamer Prefetcher	Enables or disables the Data Cache Unit (DCU) streamer prefetcher. This option is set to Enabled by default.
DCU IP Prefetcher	Enables or disables the Data Cache Unit (DCU) IP prefetcher. This option is set to Enabled by default.
Execute Disable	Enables you to run the disable memory protection technology. This option is set to Enabled by default.
Logical Processor Idling	Enables you to improve the energy efficiency of a system. It uses the operating system core parking algorithm and parks some of the logical processors in the system which in turn allows the corresponding processor cores to transition into a lower power idle state. This option can only be enabled if the operating system supports it. It is set to Disabled by default.
Configurable TDP	Enables you to reconfigure the processor Thermal Design Power (TDP) levels during POST based on the power and thermal delivery capabilities of the system. TDP verifies the maximum heat the cooling system is needed to dissipate. This option is set to Nominal by default. NOTE: This option is only available on certain stock keeping units (SKUs) of the processors.
X2Apic Mode	Enables or disables the X2Apic mode.
Dell Controlled Turbo	Controls the turbo engagement. Enable this option only when System Profile is set to Performance . NOTE: Depending on the number of installed CPUs, there may be up to four processor listings.

Option	Description
Number of Cores per Processor	Controls the number of enabled cores in each processor. This option is set to All by default.
Processor 64-bit Support	Specifies if the processor(s) support 64-bit extensions.
Processor Core Speed	Specifies the maximum core frequency of the processor.
Processor 1	 NOTE: Depending on the number of CPUs, there may be up to four processors listed.

The following settings are displayed for each processor installed in the system:

Option	Description
Family-Model-Stepping	Specifies the family, model, and stepping of the processor as defined by Intel.
Brand	Specifies the brand name.
Level 2 Cache	Specifies the total L2 cache.
Level 3 Cache	Specifies the total L3 cache.
Number of Cores	Specifies the number of cores per processor.

Related tasks

[Viewing Processor Settings](#)

Related reference

[Processor Settings](#)

SATA Settings

You can use the **SATA Settings** screen to view the SATA settings of SATA devices and enable RAID on your system.

Related tasks

[SATA Settings details](#)

[Viewing SATA Settings](#)

Related reference

[System BIOS](#)

Viewing SATA Settings

To view the **SATA Settings** screen, perform the following steps:

Steps

1. Turn on, or restart your system.
2. Press F2 immediately after you see the following message:

```
F2 = System Setup
```

 **NOTE: If your operating system begins to load before you press F2, wait for the system to finish booting, and then restart your system and try again.**

3. On the **System Setup Main Menu** screen, click **System BIOS**.
4. On the **System BIOS** screen, click **SATA Settings**.

Related tasks

[SATA Settings details](#)

Related reference

[SATA Settings](#)

SATA Settings details

About this task

The **SATA Settings** screen details are explained as follows:

Option	Description								
Embedded SATA	Enables the embedded SATA option to be set to Off , ATA , AHCI , or RAID modes. This option is set to AHCI by default.								
Security Freeze Lock	Sends Security Freeze Lock command to the Embedded SATA drives during POST. This option is applicable only for ATA and AHCI modes.								
Write Cache	Enables or disables the command for Embedded SATA drives during POST.								
Port A	<p>Sets the drive type of the selected device. For Embedded SATA settings in ATA mode, set this field to Auto to enable BIOS support. Set it to OFF to turn off BIOS support.</p> <p>For AHCI or RAID mode, BIOS support is always enabled.</p> <table><thead><tr><th>Option</th><th>Description</th></tr></thead><tbody><tr><td>Model</td><td>Specifies the drive model of the selected device.</td></tr><tr><td>Drive Type</td><td>Specifies the type of drive attached to the SATA port.</td></tr><tr><td>Capacity</td><td>Specifies the total capacity of the hard drive. This field is undefined for removable media devices such as optical drives.</td></tr></tbody></table>	Option	Description	Model	Specifies the drive model of the selected device.	Drive Type	Specifies the type of drive attached to the SATA port.	Capacity	Specifies the total capacity of the hard drive. This field is undefined for removable media devices such as optical drives.
Option	Description								
Model	Specifies the drive model of the selected device.								
Drive Type	Specifies the type of drive attached to the SATA port.								
Capacity	Specifies the total capacity of the hard drive. This field is undefined for removable media devices such as optical drives.								
Port B	<p>Sets the drive type of the selected device. For Embedded SATA settings in ATA mode, set this field to Auto to enable BIOS support. Set it to OFF to turn off BIOS support.</p> <p>For AHCI or RAID mode, BIOS support is always enabled.</p> <table><thead><tr><th>Option</th><th>Description</th></tr></thead><tbody><tr><td>Model</td><td>Specifies the drive model of the selected device.</td></tr><tr><td>Drive Type</td><td>Specifies the type of drive attached to the SATA port.</td></tr><tr><td>Capacity</td><td>Specifies the total capacity of the hard drive. This field is undefined for removable media devices such as optical drives.</td></tr></tbody></table>	Option	Description	Model	Specifies the drive model of the selected device.	Drive Type	Specifies the type of drive attached to the SATA port.	Capacity	Specifies the total capacity of the hard drive. This field is undefined for removable media devices such as optical drives.
Option	Description								
Model	Specifies the drive model of the selected device.								
Drive Type	Specifies the type of drive attached to the SATA port.								
Capacity	Specifies the total capacity of the hard drive. This field is undefined for removable media devices such as optical drives.								
Port C	<p>Sets the drive type of the selected device. For Embedded SATA settings in ATA mode, set this field to Auto to enable BIOS support. Set it to OFF to turn off BIOS support.</p> <p>For AHCI or RAID mode, BIOS support is always enabled.</p> <table><thead><tr><th>Option</th><th>Description</th></tr></thead><tbody><tr><td>Model</td><td>Specifies the drive model of the selected device.</td></tr><tr><td>Drive Type</td><td>Specifies the type of drive attached to the SATA port.</td></tr><tr><td>Capacity</td><td>Specifies the total capacity of the hard drive. This field is undefined for removable media devices such as optical drives.</td></tr></tbody></table>	Option	Description	Model	Specifies the drive model of the selected device.	Drive Type	Specifies the type of drive attached to the SATA port.	Capacity	Specifies the total capacity of the hard drive. This field is undefined for removable media devices such as optical drives.
Option	Description								
Model	Specifies the drive model of the selected device.								
Drive Type	Specifies the type of drive attached to the SATA port.								
Capacity	Specifies the total capacity of the hard drive. This field is undefined for removable media devices such as optical drives.								
Port D	<p>Sets the drive type of the selected device. For Embedded SATA settings in ATA mode, set this field to Auto to enable BIOS support. Set it to OFF to turn off BIOS support.</p> <p>For AHCI or RAID mode, BIOS support is always enabled.</p>								

Option	Description								
	<table border="0"> <tr> <td>Option</td> <td>Description</td> </tr> <tr> <td>Model</td> <td>Specifies the drive model of the selected device.</td> </tr> <tr> <td>Drive Type</td> <td>Specifies the type of drive attached to the SATA port.</td> </tr> <tr> <td>Capacity</td> <td>Specifies the total capacity of the hard drive. This field is undefined for removable media devices such as optical drives.</td> </tr> </table>	Option	Description	Model	Specifies the drive model of the selected device.	Drive Type	Specifies the type of drive attached to the SATA port.	Capacity	Specifies the total capacity of the hard drive. This field is undefined for removable media devices such as optical drives.
Option	Description								
Model	Specifies the drive model of the selected device.								
Drive Type	Specifies the type of drive attached to the SATA port.								
Capacity	Specifies the total capacity of the hard drive. This field is undefined for removable media devices such as optical drives.								
Port E	<p>Sets the drive type of the selected device. For Embedded SATA settings in ATA mode, set this field to Auto to enable BIOS support. Set it to OFF to turn off BIOS support.</p> <p>For AHCI or RAID mode, BIOS support is always enabled.</p> <table border="0"> <tr> <td>Option</td> <td>Description</td> </tr> <tr> <td>Model</td> <td>Specifies the drive model of the selected device.</td> </tr> <tr> <td>Drive Type</td> <td>Specifies the type of drive attached to the SATA port.</td> </tr> <tr> <td>Capacity</td> <td>Specifies the total capacity of the hard drive. This field is undefined for removable media devices such as optical drives.</td> </tr> </table>	Option	Description	Model	Specifies the drive model of the selected device.	Drive Type	Specifies the type of drive attached to the SATA port.	Capacity	Specifies the total capacity of the hard drive. This field is undefined for removable media devices such as optical drives.
Option	Description								
Model	Specifies the drive model of the selected device.								
Drive Type	Specifies the type of drive attached to the SATA port.								
Capacity	Specifies the total capacity of the hard drive. This field is undefined for removable media devices such as optical drives.								
Port F	<p>Sets the drive type of the selected device. For Embedded SATA settings in ATA mode, set this field to Auto to enable BIOS support. Set it to OFF to turn off BIOS support.</p> <p>For AHCI or RAID mode, BIOS support is always enabled.</p> <table border="0"> <tr> <td>Option</td> <td>Description</td> </tr> <tr> <td>Model</td> <td>Specifies the drive model of the selected device.</td> </tr> <tr> <td>Drive Type</td> <td>Specifies the type of drive attached to the SATA port.</td> </tr> <tr> <td>Capacity</td> <td>Specifies the total capacity of the hard drive. This field is undefined for removable media devices such as optical drives.</td> </tr> </table>	Option	Description	Model	Specifies the drive model of the selected device.	Drive Type	Specifies the type of drive attached to the SATA port.	Capacity	Specifies the total capacity of the hard drive. This field is undefined for removable media devices such as optical drives.
Option	Description								
Model	Specifies the drive model of the selected device.								
Drive Type	Specifies the type of drive attached to the SATA port.								
Capacity	Specifies the total capacity of the hard drive. This field is undefined for removable media devices such as optical drives.								

Related tasks

[Viewing SATA Settings](#)

Related reference

[SATA Settings](#)

Integrated Devices

You can use the **Integrated Devices** screen to view and configure the settings of all integrated devices including the video controller, integrated RAID controller, and the USB ports.

Related tasks

[Integrated Devices details](#)

[Viewing Integrated Devices](#)

Related reference

[System BIOS](#)

Viewing Integrated Devices

To view the **Integrated Devices** screen, perform the following steps:

Steps

1. Turn on, or restart your system.

2. Press F2 immediately after you see the following message:

F2 = System Setup

NOTE: If your operating system begins to load before you press F2, wait for the system to finish booting, and then restart your system and try again.

3. On the **System Setup Main Menu** screen, click **System BIOS**.
4. On the **System BIOS** screen, click **Integrated Devices**.

Related tasks

[Integrated Devices details](#)

Related reference

[Integrated Devices](#)

Integrated Devices details

About this task

The **Integrated Devices** screen details are explained as follows:

Option	Description
USB 3.0 Setting	Enables or disables the USB 3.0 support. Enable this option only if your operating system supports USB 3.0. If you disable this option, devices operate at USB 2.0 speed. USB 3.0 is enabled by default.
User Accessible USB Ports	Enables or disables the USB ports. Selecting Only Back Ports On disables the front USB ports, selecting All Ports Off disables all USB ports. The USB keyboard and mouse operate during boot process in certain operating systems. After the boot process is complete, the USB keyboard and mouse do not work if the ports are disabled. NOTE: Selecting Only Back Ports On and All Ports Off disables the USB management port and also restricts access to iDRAC features.
Internal USB Port	Enables or disables the internal USB port. This option is set to Enabled by default.
Integrated RAID Controller	Enables or disables the integrated RAID controller. This option is set to Enabled by default.
Integrated Network Card 1	Enables or disables the integrated network card.
Embedded NIC1 and NIC2	NOTE: The Embedded NIC1 and NIC2 options are only available on systems that do not have Integrated Network Card 1 . Enables or disables the Embedded NIC1 and NIC2 options. If set to Disabled , the NIC may still be available for shared network access by the embedded management controller. The embedded NIC1 and NIC2 options are only available on systems that do not have Network Daughter Cards (NDCs). The Embedded NIC1 and NIC2 option is mutually exclusive with the Integrated Network Card 1 option. Configure the Embedded NIC1 and NIC2 option by using the NIC management utilities of the system.
I/OAT DMA Engine	Enables or disables the I/OAT option. Enable only if the hardware and software support the feature.
Embedded Video Controller	Enables or disables the Embedded Video Controller option. This option is set to Enabled by default.
Current State of Embedded Video Controller	Displays the current state of the embedded video controller. The Current State of Embedded Video Controller option is a read-only field. If the Embedded Video Controller is the only display capability in the system (that is, no add-in graphics card is installed), then the Embedded Video Controller is automatically used as the primary display even if the Embedded Video Controller setting is set to Disabled .
SR-IOV Global Enable	Enables or disables the BIOS configuration of Single Root I/O Virtualization (SR-IOV) devices. This option is set to Disabled by default.
OS Watchdog Timer	If your system stops responding, this watchdog timer aids in the recovery of your operating system. When this option is set to Enabled , the operating system initializes the timer. When this option is set to Disabled (the default), the timer does not have any effect on the system.

Option	Description
Memory Mapped I/O above 4 GB	Enables or disables the support for PCIe devices that need large amounts of memory. This option is set to Enabled by default.
Slot Disablement	Enables or disables the available PCIe slots on your system. The slot disablement feature controls the configuration of PCIe cards installed in the specified slot. Slots must be disabled only when the installed peripheral card prevents booting into the operating system or causes delays in system startup. If the slot is disabled, both the Option ROM and UEFI drivers are disabled.

Related tasks

[Viewing Integrated Devices](#)

Related reference

[Integrated Devices](#)

Serial Communication

You can use the **Serial Communication** screen to view the properties of the serial communication port.

Related tasks

[Serial Communication details](#)

[Viewing Serial Communication](#)

Related reference

[System BIOS](#)

Viewing Serial Communication

To view the **Serial Communication** screen, perform the following steps:

Steps

1. Turn on, or restart your system.
2. Press F2 immediately after you see the following message:

```
F2 = System Setup
```

NOTE: If your operating system begins to load before you press F2, wait for the system to finish booting, and then restart your system and try again.

3. On the **System Setup Main Menu** screen, click **System BIOS**.
4. On the **System BIOS** screen, click **Serial Communication**.

Related tasks

[Serial Communication details](#)

Related reference

[Serial Communication](#)

Serial Communication details

About this task

The **Serial Communication** screen details are explained as follows:

Option	Description
Serial Communication	Selects serial communication devices (Serial Device 1 and Serial Device 2) in BIOS. BIOS console redirection can also be enabled and the port address can be specified. This option is set to Auto by default.
Serial Port Address	<p>Enables you to set the port address for serial devices. This option is set to Serial Device 1=COM2, Serial Device 2=COM1 by default.</p> <p>NOTE: You can use only Serial Device 2 for the Serial Over LAN (SOL) feature. To use console redirection by SOL, configure the same port address for console redirection and the serial device.</p> <p>NOTE: Every time the system boots, the BIOS syncs the serial MUX setting saved in iDRAC. The serial MUX setting can independently be changed in iDRAC. Loading the BIOS default settings from within the BIOS setup utility may not always revert the serial MUX setting to the default setting of Serial Device 1.</p>
External Serial Connector	<p>Enables you to associate the External Serial Connector to Serial Device 1, Serial Device 2, or the Remote Access Device by using this option.</p> <p>NOTE: Only Serial Device 2 can be used for Serial Over LAN (SOL). To use console redirection by SOL, configure the same port address for console redirection and the serial device.</p> <p>NOTE: Every time the system boots, the BIOS syncs the serial MUX setting saved in iDRAC. The serial MUX setting can independently be changed in iDRAC. Loading the BIOS default settings from within the BIOS setup utility may not always revert this setting to the default setting of Serial Device 1.</p>
Failsafe Baud Rate	Specifies the failsafe baud rate for console redirection. The BIOS attempts to determine the baud rate automatically. This failsafe baud rate is used only if the attempt fails, and the value must not be changed. This option is set to 115200 by default.
Remote Terminal Type	Sets the remote console terminal type. This option is set to VT 100/VT 220 by default.
Redirection After Boot	Enables or disables the BIOS console redirection when the operating system is loaded. This option is set to Enabled by default.

Related tasks

[Viewing Serial Communication](#)

Related reference

[Serial Communication](#)

System Profile Settings

You can use the **System Profile Settings** screen to enable specific system performance settings such as power management.

Related tasks

[System Profile Settings details](#)

[Viewing System Profile Settings](#)

Related reference

[System BIOS](#)

Viewing System Profile Settings

To view the **System Profile Settings** screen, perform the following steps:

Steps

1. Turn on, or restart your system.

2. Press F2 immediately after you see the following message:

F2 = System Setup

NOTE: If your operating system begins to load before you press F2, wait for the system to finish booting, and then restart your system and try again.

3. On the **System Setup Main Menu** screen, click **System BIOS**.
4. On the **System BIOS** screen, click **System Profile Settings**.

Related tasks

[System Profile Settings details](#)

Related reference



[System Profile Settings](#)

System Profile Settings details

About this task

The **System Profile Settings** screen details are explained as follows:

Option	Description
System Profile	Sets the system profile. If you set the System Profile option to a mode other than Custom , the BIOS automatically sets the rest of the options. You can only change the rest of the options if the mode is set to Custom . This option is set to Performance Per Watt Optimized (DAPC) by default. DAPC is Dell Active Power Controller. NOTE: All the parameters on the system profile setting screen are available only when the System Profile option is set to Custom .
CPU Power Management	Sets the CPU power management. This option is set to System DBPM (DAPC) by default. DBPM is Demand-Based Power Management.
Memory Frequency	Sets the speed of the system memory. You can select Maximum Performance , Maximum Reliability , or a specific speed.
Turbo Boost	Enables or disables the processor to operate in the turbo boost mode. This option is set to Enabled by default.
Energy Efficient Turbo	Enables or disables the Energy Efficient Turbo option. Energy Efficient Turbo (EET) is a mode of operation where a processor's core frequency is adjusted to be within the turbo range based on workload.
C1E	Enables or disables the processor to switch to a minimum performance state when it is idle. This option is set to Enabled by default.
C States	Enables or disables the processor to operate in all available power states. This option is set to Enabled by default.
Collaborative CPU Performance Control	Enables or disables the CPU power management option. When set to Enabled , the CPU power management is controlled by the OS DBPM and the System DBPM (DAPC). This option is set to Disabled by default.
Memory Patrol Scrub	Sets the memory patrol scrub frequency. This option is set to Standard by default.
Memory Refresh Rate	Sets the memory refresh rate to either 1x or 2x. This option is set to 1x by default.
Uncore Frequency	Enables you to select the Processor Uncore Frequency option. Dynamic mode enables the processor to optimize power resources across the cores and uncore during runtime. The optimization of the uncore frequency to either save power or optimize performance is influenced by the setting of the Energy Efficiency Policy option.
Energy Efficient Policy	Enables you to select the Energy Efficient Policy option.

Option	Description
	The CPU uses the setting to manipulate the internal behavior of the processor and determines whether to target higher performance or better power savings.
Number of Turbo Boot Enabled Cores for Processor 1	<p> NOTE: If there are two processors installed in the system, you see an entry for Number of Turbo Boost Enabled Cores for Processor 2.</p> <p>Controls the number of turbo boost enabled cores for processor 1. The maximum number of cores is enabled by default.</p>
Monitor/Mwait	<p>Enables the Monitor/Mwait instructions in the processor. This option is set to Enabled for all system profiles, except Custom by default.</p> <p> NOTE: This option can be disabled only if the C States option in the Custom mode is set to disabled.</p> <p> NOTE: When C States is set to Enabled in the Custom mode, changing the Monitor/Mwait setting does not impact the system power or performance.</p>

Related tasks

[Viewing System Profile Settings](#)

Related reference

[System Profile Settings](#)

Miscellaneous Settings

You can use the **Miscellaneous Settings** screen to perform specific functions such as updating the asset tag and changing the system date and time.

Related tasks

[Miscellaneous Settings details](#)

[Viewing Miscellaneous Settings](#)

Related reference

[System BIOS](#)

Viewing Miscellaneous Settings

To view the **Miscellaneous Settings** screen, perform the following steps:

Steps

1. Turn on, or restart your system.
2. Press F2 immediately after you see the following message:

```
F2 = System Setup
```

 **NOTE: If your operating system begins to load before you press F2, wait for the system to finish booting, and then restart your system and try again.**

3. On the **System Setup Main Menu** screen, click **System BIOS**.
4. On the **System BIOS** screen, click **Miscellaneous Settings**.

Related tasks

[Miscellaneous Settings details](#)



Related reference

[Miscellaneous Settings](#)

Miscellaneous Settings details

About this task

The **Miscellaneous Settings** screen details are explained as follows:

Option	Description
System Time	Enables you to set the time on the system.
System Date	Enables you to set the date on the system.
Asset Tag	Specifies the asset tag and enables you to modify it for security and tracking purposes.
Keyboard NumLock	Enables you to set whether the system boots with the NumLock enabled or disabled. This option is set to On by default.  NOTE: This option does not apply to 84-key keyboards.
F1/F2 Prompt on Error	Enables or disables the F1/F2 prompt on error. This option is set to Enabled by default. The F1/F2 prompt also includes keyboard errors.
Load Legacy Video Option ROM	Enables you to determine whether the system BIOS loads the legacy video (INT 10H) option ROM from the video controller. Selecting Enabled in the operating system does not support UEFI video output standards. This field is available only for UEFI boot mode. You cannot set the option to Enabled if UEFI Secure Boot mode is enabled.
In-System Characterization	Enables or disables In-System Characterization . This option is set to Disabled by default. The two other options are Enabled and Enabled - No Reboot .  NOTE: The default setting for In-System Characterization is subject to change in future BIOS releases. When enabled, In-System Characterization (ISC) executes during POST upon detecting relevant change(s) in system configuration to optimize system power and performance. ISC takes about 20 seconds to execute, and system reset is needed for ISC results to be applied. The Enabled - No Reboot option executes ISC and continues without applying ISC results until the next time system reset occurs. The Enabled option executes ISC and forces an immediate system reset so that ISC results can be applied. It takes the system longer to be ready due to the forced system reset. When disabled, ISC does not execute.

Related tasks

[Viewing Miscellaneous Settings](#)

Related reference

[Miscellaneous Settings](#)

iDRAC Settings utility

The iDRAC settings utility is an interface to set up and configure the iDRAC parameters by using UEFI. You can enable or disable various iDRAC parameters by using the iDRAC settings utility.

 **NOTE: Accessing some of the features on the iDRAC settings utility needs the iDRAC Enterprise License upgrade.**

For more information about using iDRAC, see *Dell Integrated Dell Remote Access Controller User's Guide* at Dell.com/idracmanuals.

Related concepts

[Device Settings](#)

Related tasks

[Entering the iDRAC Settings utility](#)

[Changing the thermal settings](#)

Related reference

[System BIOS](#)

Entering the iDRAC Settings utility

Steps

1. Turn on or restart the managed system.
2. Press F2 during Power-on Self-test (POST).
3. On the **System Setup Main Menu** page, click **iDRAC Settings**.
The **iDRAC Settings** screen is displayed.

Related reference

[iDRAC Settings utility](#)

Changing the thermal settings

The iDRAC settings utility enables you to select and customize the thermal control settings for your system.

1. Click **iDRAC Settings > Thermal**.
2. Under **SYSTEM THERMAL PROFILE > Thermal Profile**, select one of the following options:
 - Default Thermal Profile Settings
 - Maximum Performance (Performance Optimized)
 - Minimum Power (Performance per Watt Optimized)
3. Under **USER COOLING OPTIONS**, set the **Fan Speed Offset**, **Minimum Fan Speed**, and **Custom Minimum Fan Speed**.
4. Click **Back > Finish > Yes**.

Related reference

[iDRAC Settings utility](#)

Device Settings

Device Settings enables you to configure device parameters.

Related reference

[System BIOS](#)

Dell Lifecycle Controller

Dell Lifecycle Controller (LC) provides advanced embedded systems management capabilities including system deployment, configuration, update, maintenance, and diagnosis. LC is delivered as part of the iDRAC out-of-band solution and Dell system embedded Unified Extensible Firmware Interface (UEFI) applications.

Related reference

[Embedded system management](#)

Embedded system management

The Dell Lifecycle Controller provides advanced embedded systems management throughout the system's lifecycle. The Dell Lifecycle Controller can be started during the boot sequence and can function independently of the operating system.

 **NOTE: Certain platform configurations may not support the full set of features provided by the Dell Lifecycle Controller.**

For more information about setting up the Dell Lifecycle Controller, configuring hardware and firmware, and deploying the operating system, see the Dell Lifecycle Controller documentation at Dell.com/idracmanuals.

Related reference

[Dell Lifecycle Controller](#)

Boot Manager

The **Boot Manager** screen enables you to select boot options and diagnostic utilities.

Related tasks

[Viewing Boot Manager](#)

Related reference

[Boot Manager main menu](#)

[System BIOS](#)

Viewing Boot Manager

To enter **Boot Manager**:

Steps

1. Turn on, or restart your system.
2. Press F11 when you see the following message:

```
F11 = Boot Manager
```

If your operating system begins to load before you press F11, allow the system to complete the booting, and then restart your system and try again.

Related reference

[Boot Manager](#)

[Boot Manager main menu](#)

Boot Manager main menu

Menu item	Description
Continue Normal Boot	The system attempts to boot to devices starting with the first item in the boot order. If the boot attempt fails, the system continues with the next item in the boot order until the boot is successful or no more boot options are found.
One-shot Boot Menu	Enables you to access boot menu, where you can select a one-time boot device to boot from.
Launch System Setup	Enables you to access System Setup.
Launch Lifecycle Controller	Exits the Boot Manager and invokes the Dell Lifecycle Controller program.
System Utilities	Enables you to launch System Utilities menu such as System Diagnostics and UEFI shell.

Related tasks

[Viewing Boot Manager](#)

Related reference

[Boot Manager](#)

One-shot BIOS boot menu

One-shot BIOS boot menu enables you to select a boot device to boot from.

Related reference

[Boot Manager](#)

System Utilities

System Utilities contains the following utilities that can be launched:

- Launch Diagnostics
- BIOS Update File Explorer
- Reboot System

Related reference







[Boot Manager](#)

PXE boot

The Preboot Execution Environment (PXE) is an industry standard client or interface that allows networked computers that are not yet loaded with an operating system to be configured and booted remotely by an administrator.

Installing and removing system components

Safety instructions

-  **NOTE:** Whenever you need to lift the system, get others to assist you. To avoid injury, do not attempt to lift the system by yourself.
-  **WARNING:** Opening or removing the system cover while the system is powered on may expose you to a risk of electric shock.
-  **CAUTION:** Do not operate the system without the cover for a duration exceeding five minutes.
-  **CAUTION:** Many repairs may only be done by a certified service technician. You should only perform troubleshooting and simple repairs as authorized in your product documentation, or as directed by the online or telephone service and support team. Damage due to servicing that is not authorized by Dell is not covered by your warranty. Read and follow the safety instructions that are shipped with your product.
-  **NOTE:** Dell recommends that you always use a static mat and static strap while working on components inside the system.
-  **NOTE:** To ensure proper operation and cooling, all bays in the system and system fans must be populated always with either a component or with a blank.

Before working inside your system

Prerequisites

Follow the safety guidelines listed in the Safety instructions section.

Steps

1. Turn off the system, including any attached peripherals.
2. Disconnect the system from the electrical outlet and disconnect the peripherals.
3. If installed, remove the front bezel.
4. If applicable, remove the system from the rack.
For more information, see the *Rack Installation* placemat at Dell.com/poweredgemanuals.
5. Remove the system cover.

Related tasks

[Removing the optional front bezel](#)
[Removing the system cover](#)

After working inside your system

Prerequisites

Follow the safety guidelines listed in the Safety instructions section.

Steps

1. Install the system cover.

2. If applicable, install the system into the rack.
For more information, see the *Rack Installation* placemat at [Dell.com/poweredgemanuals](https://www.dell.com/poweredge/manuals).
3. If removed, install the optional front bezel.
4. Reconnect the peripherals and connect the system to the electrical outlet.
5. Turn on the system, including any attached peripherals.

Related tasks

[Installing the system cover](#)

[Installing the optional front bezel](#)

Recommended tools

You need the following tools to perform the removal and installation procedures:

- Key to the bezel lock.
This is needed only if your system includes a bezel.
- Phillips #2 screwdriver
- Wrist grounding strap

You need the following tools to assemble the cables for a DC power supply unit.

- AMP 90871-1 hand-crimping tool or equivalent
- Tyco Electronics 58433-3 or equivalent
- Wire-stripper pliers to remove insulation from size 10 AWG solid or stranded, insulated copper wire

 **NOTE: Use alpha wire part number 3080 or equivalent (65/30 stranding).**

Front bezel (optional)

The front bezel is attached to the front side of the server and prevents accidents while removing the hard drive or when pressing the reset or power button. The front bezel can also be locked for additional security.

Removing the optional front bezel

Prerequisites

Follow the safety guidelines listed in the Safety instructions section.

Steps

1. Locate and remove the bezel key.
 **NOTE: The bezel key is attached to the back of the bezel.**
2. Unlock the bezel by using the key.
3. Slide the release latch up and pull the left end of the bezel.
4. Unhook the right end, and remove the bezel.

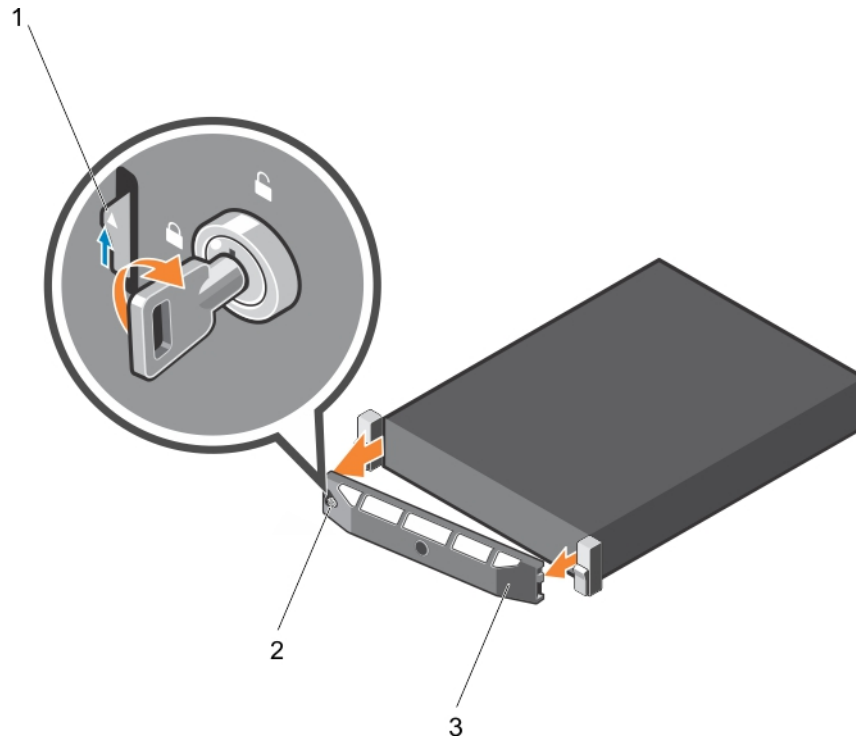

Figure 8. Removing the optional front bezel

- a. release latch
- b. bezel lock
- c. front bezel

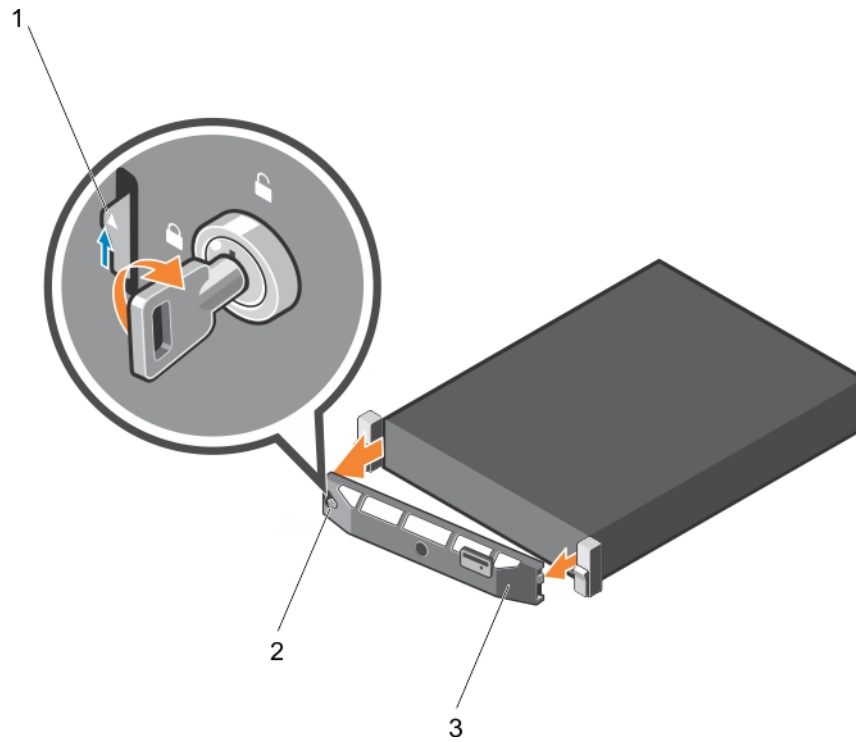

Figure 9. Removing the optional Quick Sync front bezel

- a. release latch
- b. bezel lock
- c. Quick Sync bezel

Installing the optional front bezel

Prerequisites

Follow the safety guidelines listed in the Safety instructions section.

Steps

1. Locate and remove the bezel key.

 **NOTE: The bezel key is attached to the back of the bezel.**

2. Hook the right end of the bezel onto the chassis.
3. Fit the free end of the bezel onto the system.
4. Lock the bezel by using the key.

System cover

The system cover protects the components inside the system and helps in maintaining air flow inside the system. Removing the system cover actuates the intrusion switch which aids in maintaining system security.

Removing the system cover

Prerequisites

1. Follow the safety guidelines listed in the Safety instructions section.
2. Turn off the system, including any attached peripherals.
3. Disconnect the system from the electrical outlet and disconnect the peripherals.
4. If installed, remove the optional bezel. For more information, see the Removing the optional front bezel section.

Steps

1. Rotate the latch release lock counter clockwise to the unlocked position.
2. Lift the latch toward the back of the system.

The system cover slides back and the tabs on the system cover disengage from the slots on the chassis.

 **NOTE: The position of the latch may vary depending on the configuration of your system.**

3. Hold the cover on both sides, and lift the cover away from the system.

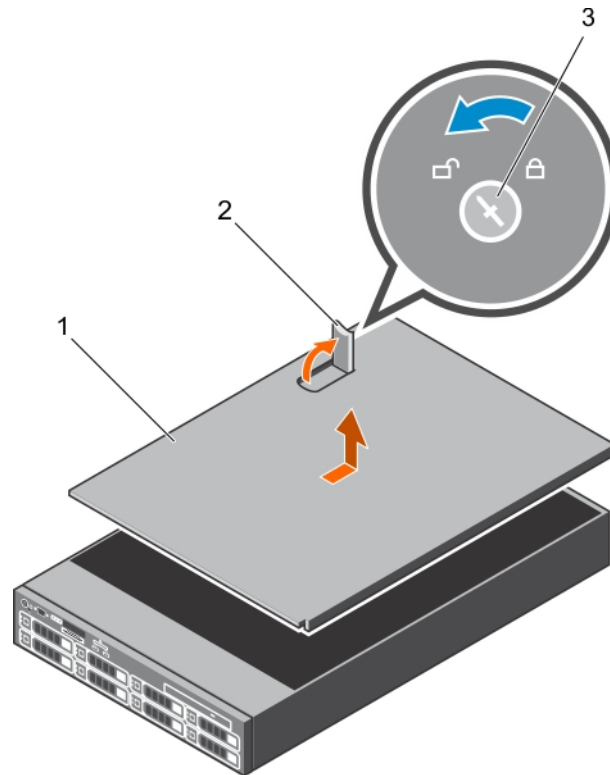

Figure 10. Removing the system cover

- a. system cover
- b. latch
- c. latch release lock

Next steps

1. Install the system cover.

Related tasks

- [Removing the optional front bezel](#)
- [Installing the system cover](#)

Related reference

- [Safety instructions](#)

Installing the system cover

Prerequisites

1. Follow the safety guidelines listed in the Safety instructions section.
2. Ensure that all internal cables are connected and placed out of the way and no tools or extra parts are left inside the system.

Steps

1. Align the slots on the system cover with the tabs on the chassis.
2. Push the system cover latch down to move the system cover into the closed position.
The system cover slides forward and the slots on the system cover engage with the tabs on the chassis. The system cover latch locks into place when the system cover is completely engaged with the tabs on the chassis.
3. Rotate the latch release lock clockwise to the locked position.

Next steps

1. If removed, install the front bezel.
2. Reconnect the peripherals and connect the system to the electrical outlet.
3. Turn on the system, including any attached peripherals.

Related tasks

[Installing the optional front bezel](#)

Related reference

[Safety instructions](#)

Inside the system

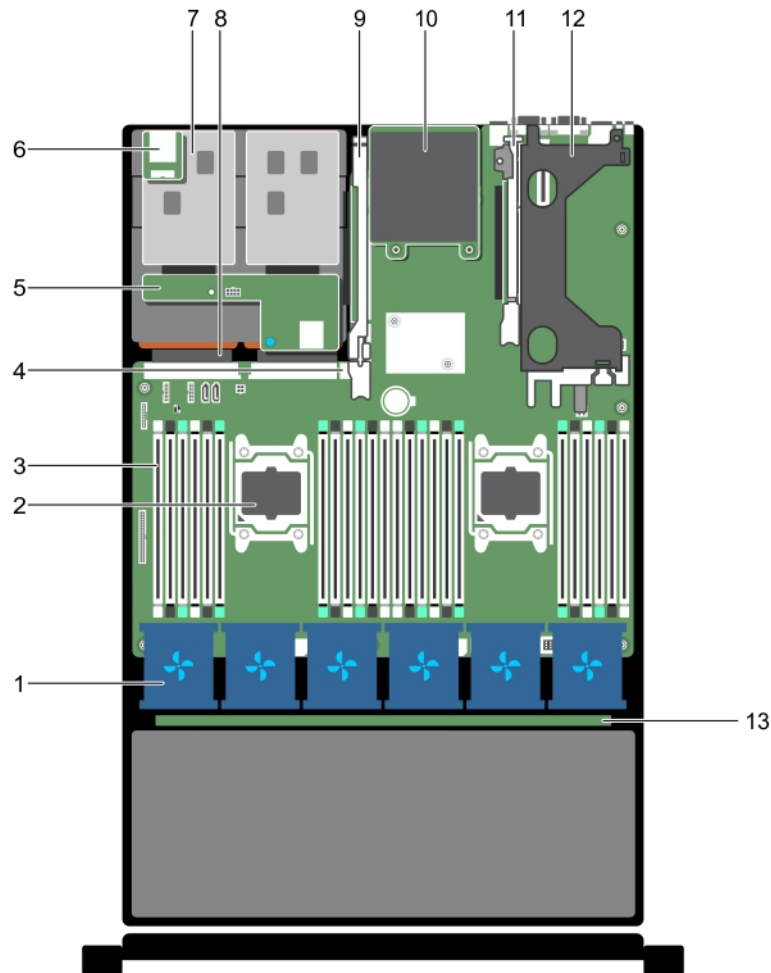

Figure 11. Inside the system

- | | |
|--|----------------------------|
| 1. cooling fan in the cooling fan assembly (6) | 2. processor (2) |
| 3. DIMMs (24) | 4. internal USB port |
| 5. hard drive backplane (back) | 6. vFlash media slot |
| 7. hard drive (2) (back) | 8. power supply unit (2) |
| 9. expansion card riser 3 | 10. network daughter card |
| 11. expansion card riser 2 | 12. expansion card riser 1 |
| 13. hard drive backplane | |

Cooling shroud

The cooling shroud has aerodynamically placed openings that direct the airflow across the entire system. The airflow passes through all the critical parts of the system, where the vacuum pulls air across the entire surface area of the heat sink, thus allowing increased cooling.

Removing the cooling shroud

Prerequisites

CAUTION: Many repairs may only be done by a certified service technician. You should only perform troubleshooting and simple repairs as authorized in your product documentation, or as directed by the online or telephone service and support team. Damage due to servicing that is not authorized by Dell is not covered by your warranty. Read and follow the safety instructions that are shipped with your product.

CAUTION: Never operate your system with the cooling shroud removed. The system may get overheated quickly, resulting in shutdown of the system and loss of data.

1. Follow the safety guidelines listed in the Safety instructions section.
2. Follow the procedure listed in the Before working inside your system section.
3. If installed, remove the full-length PCIe card.

Steps

Holding the touch points, lift the cooling shroud away from the system.

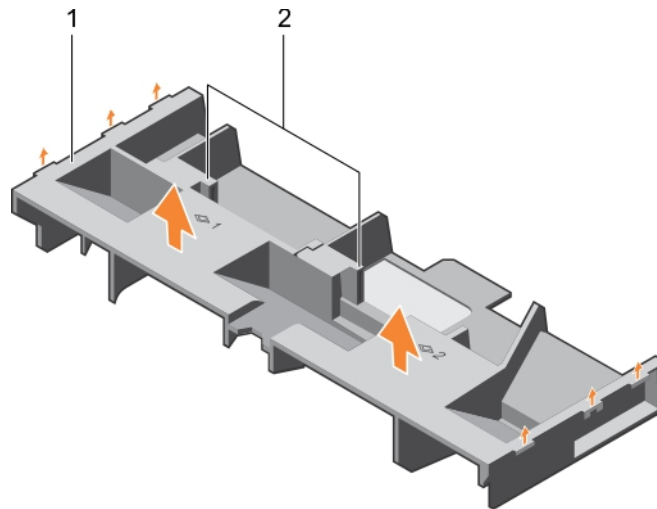

Figure 12. Removing the cooling shroud

- a. cooling shroud
- b. touch point (2)

Next steps

1. Install the cooling shroud.
2. If required, install the full-length PCIe card.
3. Follow the procedure listed in the After working inside your system section.

Related tasks

[Before working inside your system](#)

[Removing an expansion card from expansion card riser 2 or 3](#)

[Installing the cooling shroud](#)

[After working inside your system](#)

Related reference

[Safety instructions](#)

Installing the cooling shroud

Prerequisites

CAUTION: Many repairs may only be done by a certified service technician. You should only perform troubleshooting and simple repairs as authorized in your product documentation, or as directed by the online or telephone service and support team. Damage due to servicing that is not authorized by Dell is not covered by your warranty. Read and follow the safety instructions that are shipped with your product.

1. Follow the safety guidelines listed in the Safety instructions section.
2. Follow the procedure listed in the Before working inside your system section.
3. If applicable, route the cables inside the system along the chassis wall and secure the cables by using the cable-securing bracket.

Steps

1. Align the tabs on the cooling shroud with the securing slots on the chassis.
2. Lower the cooling shroud into the chassis until it is firmly seated.

Next steps

1. If removed, install the full-length PCIe card.
2. Follow the procedure listed in the After working inside your system section.

Related tasks

[Before working inside your system](#)

[Installing an expansion card into the expansion card riser 2 or 3](#)

[Installing an expansion card into the expansion card riser 1](#)

[After working inside your system](#)

Related reference

[Safety instructions](#)

Cooling fans

Your system supports six hot-swappable cooling fans.

NOTE: In the event of a problem with a particular fan, the fan number is referenced by the system management software, allowing you to easily identify and replace the proper fan by noting the fan numbers on the cooling fan assembly.

Removing a cooling fan

Prerequisites

1. Follow the safety guidelines listed in the Safety instructions section.
2. Follow the procedure listed in the Before working inside your system section.

CAUTION: Many repairs may only be done by a certified service technician. You should only perform troubleshooting and simple repairs as authorized in your product documentation, or as directed by the online or telephone service and support team. Damage due to servicing that is not authorized by Dell is not covered by your warranty. Read and follow the safety instructions that are shipped with your product.

CAUTION: The cooling fans are hot-swappable. To maintain proper cooling while the system is on, replace only one fan at a time.

NOTE: The procedure for removing each fan is identical.

Steps

Press the fan release tab and lift the cooling fan out of the cooling fan assembly.

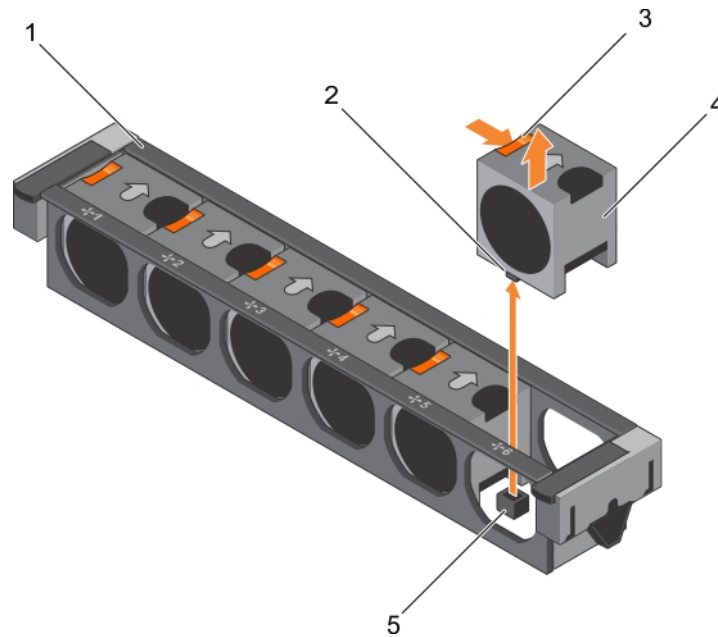

Figure 13. Removing a cooling fan

1. cooling fan assembly
2. cooling fan connector (6)
3. fan release tab (6)
4. cooling fan (6)
5. cooling fan connector on the system board (6)

Next steps

1. Install the cooling fan.
2. Follow the procedure listed in the After working inside your system section.

Related tasks

[Before working inside your system](#)

[Installing a cooling fan](#)

[After working inside your system](#)

Related reference

[Safety instructions](#)

Installing a cooling fan

Prerequisites

CAUTION: Many repairs may only be done by a certified service technician. You should only perform troubleshooting and simple repairs as authorized in your product documentation, or as directed by the online or telephone service and support team. Damage due to servicing that is not authorized by Dell is not covered by your warranty. Read and follow the safety instructions that are shipped with your product.

1. Follow the safety guidelines listed in the Safety instructions section.
2. Follow the procedure listed in the Before working inside your system section.

NOTE: The procedure for installing each fan is identical.

Steps

1. Align the connector at the base of the cooling fan with the connector on the system board.
2. Slide the cooling fan into the securing slot until the tab locks into place.

Next steps

Follow the procedure listed in the After working inside your system section.

Related tasks

[Before working inside your system](#)

[After working inside your system](#)

Related reference

[Safety instructions](#)

Cooling-fan assembly

The cooling fan assembly is an essential part of a server's cooling system. It ensures that the key components of the server such as the processors, hard drives, and memory get adequate air circulation to keep them cool. A failure in the server's cooling system can result in the server overheating and may lead to damage.

Removing the cooling fan assembly

Prerequisites

1. Follow the safety guidelines listed in the Safety instructions section.
2. Follow the procedure listed in the Before working inside your system section.

 **CAUTION:** Many repairs may only be done by a certified service technician. You should only perform troubleshooting and simple repairs as authorized in your product documentation, or as directed by the online or telephone service and support team. Damage due to servicing that is not authorized by Dell is not covered by your warranty. Read and follow the safety instructions that are shipped with your product.

Steps

1. Unlock the cooling fan assembly from the chassis by lifting the release levers.
2. Lift the cooling fan assembly out of the chassis.

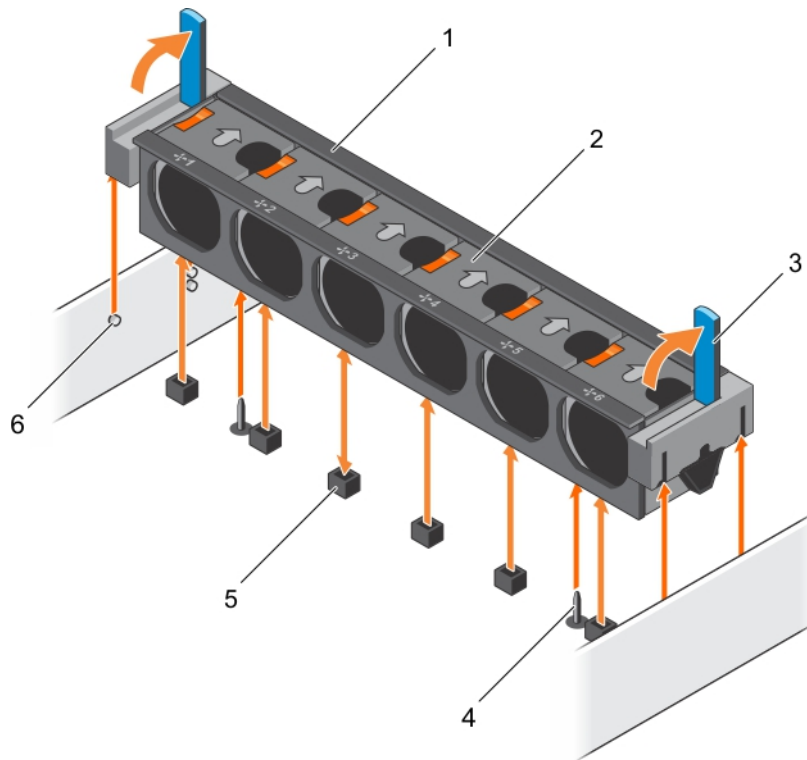

Figure 14. Removing the cooling fan assembly

- | | |
|------------------------------|--------------------------------------|
| 1. cooling fan assembly | 2. cooling fan (6) |
| 3. release lever (2) | 4. guide pin on the system board (2) |
| 5. cooling fan connector (6) | 6. guide pin on the chassis (6) |

Next steps

1. Install the cooling fan assembly.
2. Follow the procedure listed in the After working inside your system section.

Related tasks

- [Before working inside your system](#)
- [Installing the cooling fan assembly](#)
- [After working inside your system](#)

Related reference

- [Safety instructions](#)

Installing the cooling fan assembly

Prerequisites

CAUTION: Many repairs may only be done by a certified service technician. You should only perform troubleshooting and simple repairs as authorized in your product documentation, or as directed by the online or telephone service and support team. Damage due to servicing that is not authorized by Dell is not covered by your warranty. Read and follow the safety instructions that are shipped with your product.

1. Follow the safety guidelines listed in Safety instructions section.
2. Follow the procedure listed in the Before working inside your system section.

CAUTION: Ensure that the cables are correctly installed and retained by the cable retention bracket before installing the cooling fan assembly. Incorrectly installed cables may get damaged.

Steps

1. Align the slots on the cooling fan assembly with the guide pins on the chassis.
2. Slide the cooling fan assembly into the chassis.
3. Lock the cooling fan assembly into the chassis by lowering the release levers until firmly seated.

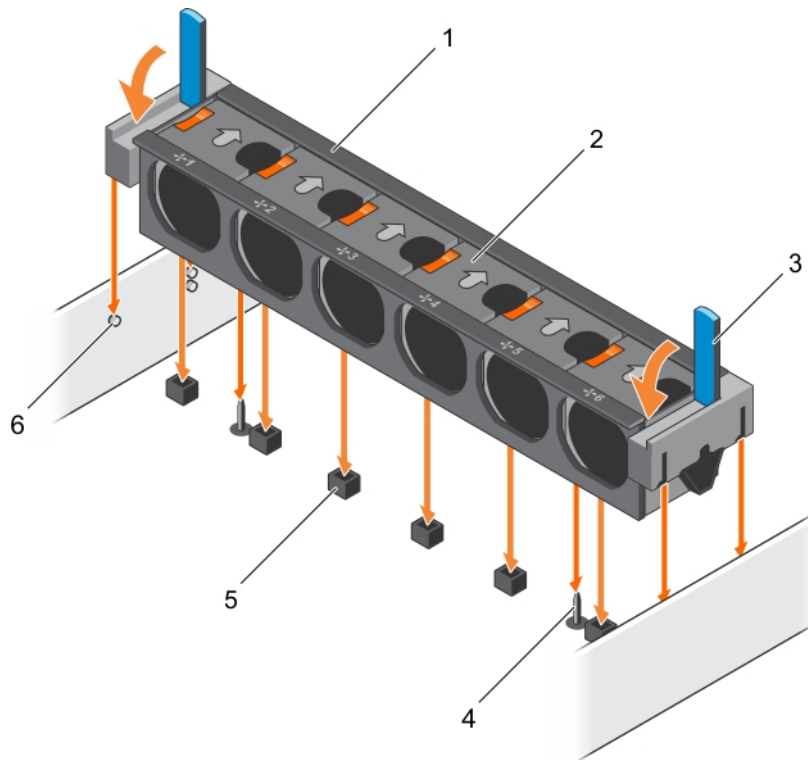

Figure 15. Installing the cooling fan assembly

- | | |
|------------------------------|--------------------------------------|
| 1. cooling fan assembly | 2. cooling fan (6) |
| 3. release lever (2) | 4. guide pin on the system board (2) |
| 5. cooling fan connector (6) | 6. guide pin on the chassis (6) |

Next steps

Follow the procedure listed in the After working inside your system section.

Related tasks

[Before working inside your system](#)

[After working inside your system](#)

Related reference

[Safety instructions](#)

System memory

Your system supports DDR4 registered DIMMs (RDIMMs). System memory holds the instructions that are executed by the processor.

NOTE: MT/s indicates DIMM speed in MegaTransfers per second.

Memory bus operating frequency can be 1866 MT/s, 2133 MT/s, or 2400 MT/s depending on the following factors:

- DIMM type (RDIMM)
- DIMM type (RDIMM or LRDIMM)
- Number of DIMMs populated per channel
- System profile selected (for example, Performance Optimized, Custom, or Dense Configuration Optimized)

- Maximum supported DIMM frequency of the processors

Your system contains 24 memory sockets split into two sets of 12 sockets, one set per processor. Each 12-socket set is organized into four channels. In each channel, the release tabs of the first socket are marked white, the second socket black, and the third socket green.

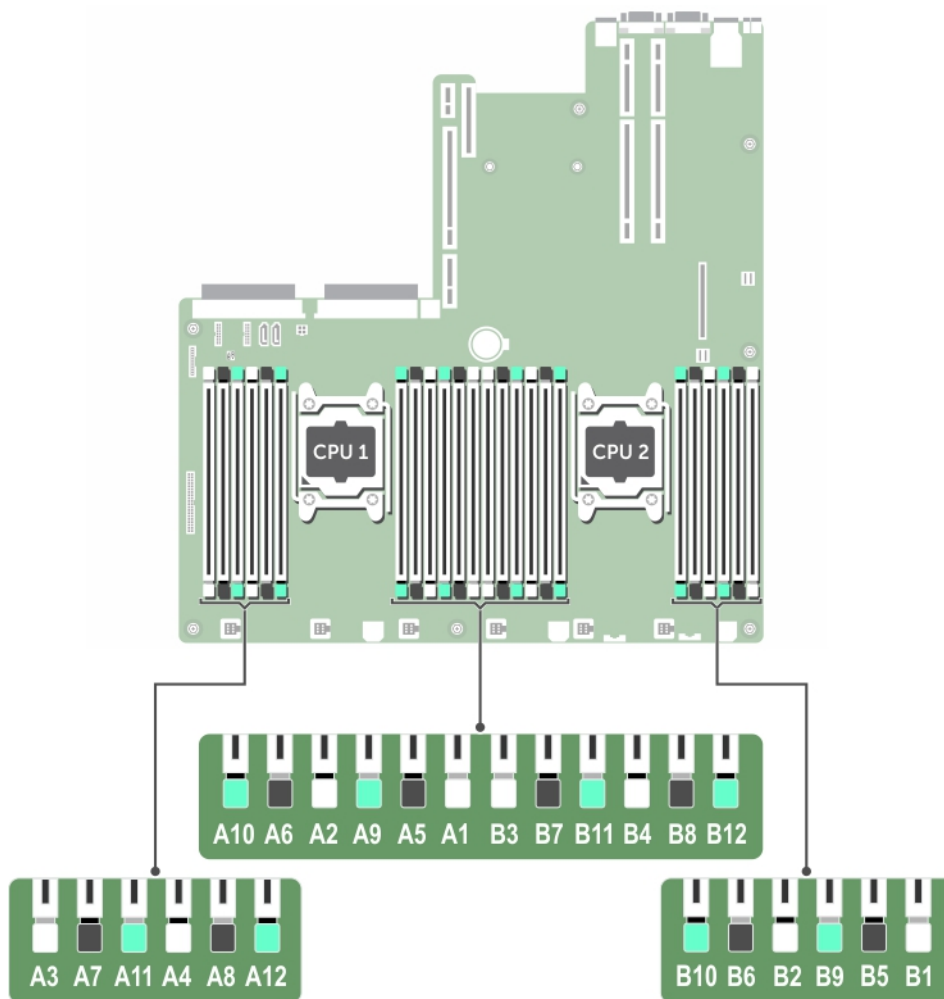

Figure 16. Memory socket locations

Memory channels are organized as follows:

Table 29. Memory channels

Processor	Channel 0	Channel 1	Channel 2	Channel 3
Processor 1	Slots A1, A5, and A9	Slots A2, A6, and A10	Slots A3, A7, and A11	Slots A4, A8, and A12
Processor 2	Slots B1, B5, and B9	Slots B2, B6, and B10	Slots B3, B7, and B11	Slots B4, B8, and B12

The following table shows the memory populations and operating frequencies for the supported configurations:

Table 30. Memory population

DIMM Type	DIMMs Populated/Channel	Voltage	Operating Frequency (in MT/s)	Maximum DIMM Rank/Channel
RDIMM	1	1.2 V	2133, 1866, 1600, 1333	Dual rank or single rank
	2		2133, 1866, 1600, 1333	Dual rank or single rank
	3		1866, 1600, 1333	Dual rank or single rank

General memory module installation guidelines

NOTE: Memory configurations that fail to observe these guidelines can prevent your system from booting, stop responding during memory configuration, or operating with reduced memory.

The system supports Flexible Memory Configuration, enabling the system to be configured and run in any valid chipset architectural configuration. The following are the recommended guidelines for installing memory modules:

- x4 and x8 DRAM based memory modules can be mixed. For more information, see the Mode-specific guidelines section.
- Up to three dual- or single-rank RDIMMs can be populated per channel.
- If memory modules with different speeds are installed, they will operate at the speed of the slowest installed memory module(s) or slower depending on system DIMM configuration.
- Populate memory module sockets only if a processor is installed. For single-processor systems, sockets A1 to A12 are available. For dual-processor systems, sockets A1 to A12 and sockets B1 to B12 are available.
- Populate all the sockets with white release tabs first, followed by the black release tabs, and then the green release tabs.
- When mixing memory modules with different capacities, populate the sockets with memory modules with highest capacity first. For example, if you want to mix 4 GB and 8 GB memory modules, populate 8 GB memory modules in the sockets with white release tabs and 4 GB memory modules in the sockets with black release tabs.
- In a dual-processor configuration, the memory configuration for each processor should be identical. For example, if you populate socket A1 for processor 1, then populate socket B1 for processor 2, and so on.
- Memory modules of different capacities can be mixed provided other memory population rules are followed (for example, 4 GB and 8 GB memory modules can be mixed).
- Mixing of more than two memory module capacities in a system is not supported.
- Populate four memory modules per processor (one DIMM per channel) at a time to maximize performance.

Mode-specific guidelines

Four memory channels are allocated to each processor. The allowable configurations depend on the memory mode selected.

Advanced Error Correction Code (lockstep)

Advanced Error Correction Code (ECC) mode extends SDDC from x4 DRAM based DIMMs to both x4 and x8 DRAMs. This protects against single DRAM chip failures during normal operation.

The installation guidelines for memory modules are as follows:

- Memory modules must be identical in size, speed, and technology.
- DIMMs installed in memory sockets with white release levers must be identical and the same rule applies for sockets with black release levers. This ensures that identical DIMMs are installed in matched pair—for example, A1 with A2, A3 with A4, A5 with A6, and so on.

Memory optimized (independent channel) mode

This mode supports Single Device Data Correction (SDDC) only for memory modules that use x4 device width. It does not impose any specific slot population requirements.

Memory sparing

NOTE: To use memory sparing, this feature must be enabled in System Setup.

In this mode, one rank per channel is reserved as a spare. If persistent correctable errors are detected on a rank, the data from this rank is copied to the spare rank, and the failed rank is disabled.

With memory sparing enabled, the system memory available to the operating system is reduced by one rank per channel. For example, in a dual-processor configuration with sixteen 4 GB single-rank memory modules, the available system memory is: $\frac{3}{4}$ (ranks/channel) \times 16 (memory modules) \times 4 GB = 48 GB, and not 16 (memory modules) \times 4 GB = 64 GB.

NOTE: Memory sparing does not offer protection against a multi-bit uncorrectable error.

NOTE: Both Advanced ECC/Lockstep and Optimizer modes support memory sparing.

Memory mirroring

Memory mirroring offers the strongest memory module reliability mode compared to all other modes, providing improved uncorrectable multi-bit failure protection. In a mirrored configuration, the total available system memory is one half of the total installed physical memory. Half of the installed memory is used to mirror the active memory modules. In the event of an uncorrectable error, the system switches over to the mirrored copy. This ensures SDDC and multi-bit protection.

The installation guidelines for memory modules are as follows:

- Memory modules must be identical in size, speed, and technology.
- Memory modules installed in memory module sockets with white release levers must be identical and the same rule applies for sockets with black and green release tabs. This ensures that identical memory modules are installed in matched pairs—for example, A1 with A2, A3 with A4, A5 with A6, and so on.

Table 31. Processor configuration

Processor	Configuration	Memory population rules	Memory population information
Single CPU	Memory population order	{1,2}, {3,4}	See Memory mirroring note

Sample memory configurations

The following table shows sample memory configurations for two processor configuration that follows the appropriate memory guidelines.

NOTE: 1R and 2R in the following table indicates single and dual ranks DIMMs respectively.

Table 32. Sample Memory configurations

System capacity (in GB)	DIMM size (in GB)	Number of DIMMs	DIMM rank, organization, and frequency	DIMM slot population
64	4	16	1R, x8, 2400 MT/s 1R, x8, 2133 MT/s	A1, A2, A3, A4, A5, A6, A7, A8, B1, B2, B3, B4, B5, B6, B7, B8
	8	8	1R, x8, 2400 MT/s 1R, x8, 2133 MT/s	A1, A2, A3, A4, B1, B2, B3, B4

Removing memory modules

Prerequisites

CAUTION: Many repairs may only be done by a certified service technician. You should only perform troubleshooting and simple repairs as authorized in your product documentation, or as directed by the online or telephone service and support team. Damage due to servicing that is not authorized by Dell is not covered by your warranty. Read and follow the safety instructions that are shipped with your product.

1. Follow the safety guidelines listed in the Safety instructions section.
2. Follow the procedure listed in the Before working inside your system section.
3. Remove the cooling shroud.
4. If installed, remove the cooling fan assembly. For more information, see the Removing the cooling fan assembly section.

NOTE: The memory modules are hot to touch for some time after the system has been powered down. Allow the memory modules to cool before handling them. Handle the memory modules by the card edges and avoid touching the components or metallic contacts on the memory module.

CAUTION: To ensure proper system cooling, memory module blanks must be installed in any memory socket that is not occupied. Remove memory module blanks only if you intend to install memory modules in those sockets.

Steps

1. Locate the appropriate memory module socket.

CAUTION: Handle each memory module only by the card edges, ensuring not to touch the middle of the memory module or metallic contacts.

2. To release the memory module from the socket, simultaneously press the ejectors on both ends of the memory module socket.
3. Lift and remove the memory module from the system.

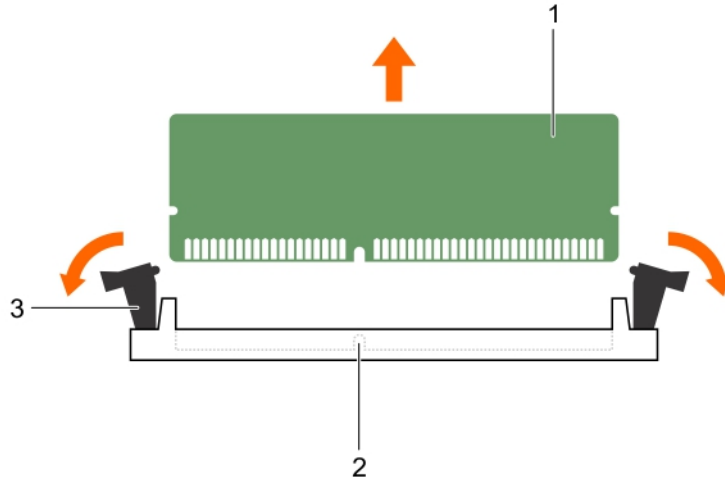

Figure 17. Removing the memory module

- a. memory module
- b. memory module socket
- c. memory module socket ejector (2)

Next steps

1. Install the memory module.
 - NOTE:** If you are removing the memory module permanently, install a memory module blank.
2. Install the cooling shroud.
3. Follow the procedure listed in the After working inside your system section.

Related tasks

[Before working inside your system](#)
[Removing the cooling shroud](#)
[Removing the cooling fan assembly](#)
[After working inside your system](#)

Related reference

[Safety instructions](#)

Installing memory modules

Prerequisites

NOTE: The memory modules are hot to touch for some time after the system has been powered down. Allow the memory modules to cool before handling them. Handle the memory modules by the card edges and avoid touching the components or metallic contacts on the memory module.

CAUTION: Many repairs may only be done by a certified service technician. You should only perform troubleshooting and simple repairs as authorized in your product documentation, or as directed by the online or telephone service and

support team. Damage due to servicing that is not authorized by Dell is not covered by your warranty. Read and follow the safety instructions that are shipped with your product.

1. Follow the safety guidelines listed in the Safety instructions section.
2. Follow the procedure listed in the Before working inside your system section.

Steps

1. Locate the appropriate memory module socket.

CAUTION: Handle each memory module only by the card edges, ensuring not to touch the middle of the memory module or metallic contacts.

2. Open the ejectors on the memory module socket outward to allow the memory module to be inserted into the socket.
3. Align the edge connector of the memory module with the alignment key of the memory module socket, and insert the memory module in the socket.

CAUTION: Do not apply pressure at the center of the memory module; apply pressure at both ends of the memory module evenly.

NOTE: The memory module socket has an alignment key that enables you to install the memory module in the socket in only one orientation.

4. Press the memory module with your thumbs until the socket levers firmly click into place.

When the memory module is properly seated in the socket, the levers on the memory module socket align with the levers on the other sockets that have memory modules installed.

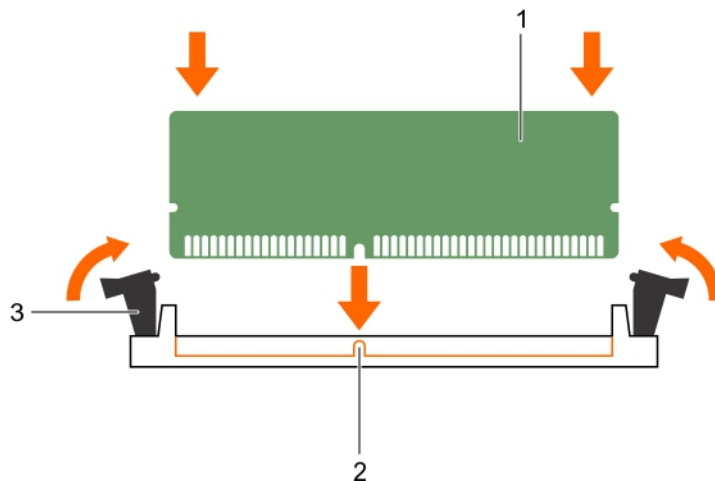

Figure 18. Installing the memory module

- a. memory module
- b. alignment key
- c. memory module socket ejector (2)

Next steps

1. Follow the procedure listed in the After working inside your system section.
2. Press F2 to enter System Setup, and check the **System Memory** setting.

The system should have already changed the value to reflect the installed memory.

3. If the value is incorrect, one or more of the memory modules may not be installed properly. Ensure that the memory module is firmly seated in the memory module socket.
4. Run the system memory test in system diagnostics.

Related tasks

[Before working inside your system](#)
[Removing the cooling shroud](#)
[Removing the cooling fan assembly](#)
[After working inside your system](#)

Related reference

[Safety instructions](#)

Processors and heat sinks

Use the following procedure when:

- Removing and installing a heat sink
- Installing an additional processor
- Replacing a processor

 **NOTE:** To ensure proper system cooling, you must install a processor blank in any empty processor socket.

Removing a heat sink

Prerequisites

 **CAUTION:** Never remove the heat sink from a processor unless you intend to remove the processor. The heat sink is necessary to maintain proper thermal conditions.

 **WARNING:** The heat sink will be hot to touch. Allow the heat sink to cool for some time after powering down the system.

1. Follow the safety guidelines listed in the Safety instructions section.
2. Keep the Phillips #2 screwdriver ready.
3. Follow the procedure listed in the Before working inside your system section.
4. If installed, remove the full-length PCIe card(s).
5. Remove the cooling shroud.

Steps

1. Loosen one of the screws that secure the heat sink to the system board.
Allow some time (approximately 30 seconds) for the heat sink to loosen from the processor.
2. Remove the screw diagonally opposite the screw you first removed.
3. Repeat the procedure for the remaining two screws.
4. Remove the heat sink.

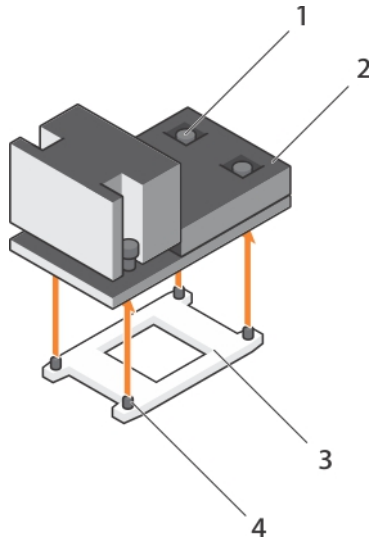

Figure 19. Removing a heat sink

- | | |
|------------------------|-----------------------------|
| 1. retention screw (4) | 2. heat sink |
| 3. processor shield | 4. retention screw slot (4) |

Next steps

1. Replace the heat sink(s) and processor(s).
2. Follow the procedure listed in the After working inside your system section.

Related tasks

[Before working inside your system](#)

[Removing an expansion card from expansion card riser 2 or 3](#)

[Removing the cooling shroud](#)

[Removing a processor](#)

[Installing a processor](#)

[Installing a heat sink](#)

[Installing the cooling shroud](#)

[Installing an expansion card into the expansion card riser 2 or 3](#)

[After working inside your system](#)

Related reference

[Safety instructions](#)

Removing a processor

Prerequisites

CAUTION: Many repairs may only be done by a certified service technician. You should only perform troubleshooting and simple repairs as authorized in your product documentation, or as directed by the online or telephone service and support team. Damage due to servicing that is not authorized by Dell is not covered by your warranty. Read and follow the safety instructions that are shipped with your product.

NOTE: This is a Field Replaceable Unit (FRU). Removal and installation procedures should be performed only by Dell certified service technicians.

NOTE: If you are upgrading your system, download the latest system BIOS version from Dell.com/support and follow the instructions included in the compressed download file to install the update on your system.

NOTE: You can update the system BIOS by using the Dell Lifecycle Controller.



 **NOTE:** To ensure proper system cooling, you must install a processor blank in any empty processor socket.

1. Follow the safety guidelines listed in the Safety instructions section.
2. Follow the procedure listed in the Before working inside your system section.
3. Keep the Phillips #2 screwdriver ready.
4. If installed, remove the full-length PCIe card(s).
5. Remove the cooling shroud.
6. Remove the heat sink.

 **WARNING:** The processor is hot to touch for some time after the system has been powered down. Allow the processor to cool before removing it.

 **CAUTION:** The processor is held in its socket under strong pressure. Be aware that the release lever can spring up suddenly if not firmly grasped.

Steps

1. Release the *open first* socket lever near the unlock icon  by pushing the lever down and out from under the tab.
 2. Release the *close first* socket release lever near the lock icon  by pushing the lever down and out from under the tab. Lift the lever 90 degrees upward.
 3. Lower the *open first* socket-release lever to lift the processor shield.
 4. Hold the tab on the processor shield and lift the processor shield until the *open first* socket-release lever lifts up.
-  **CAUTION:** The socket pins are fragile and can be permanently damaged. Be careful not to bend the pins in the socket when removing the processor out of the socket.
5. Lift the processor out of the socket and leave the *open first* socket-release lever up.

 **NOTE:** If you are permanently removing the processor, you must install a socket protective cap in the vacant socket to protect the socket pins and keep the socket free of dust.

 **NOTE:** After removing the processor, place it in an anti-static container for reuse, return, or temporary storage. Do not touch the bottom of the processor. Touch only the side edges of the processor.

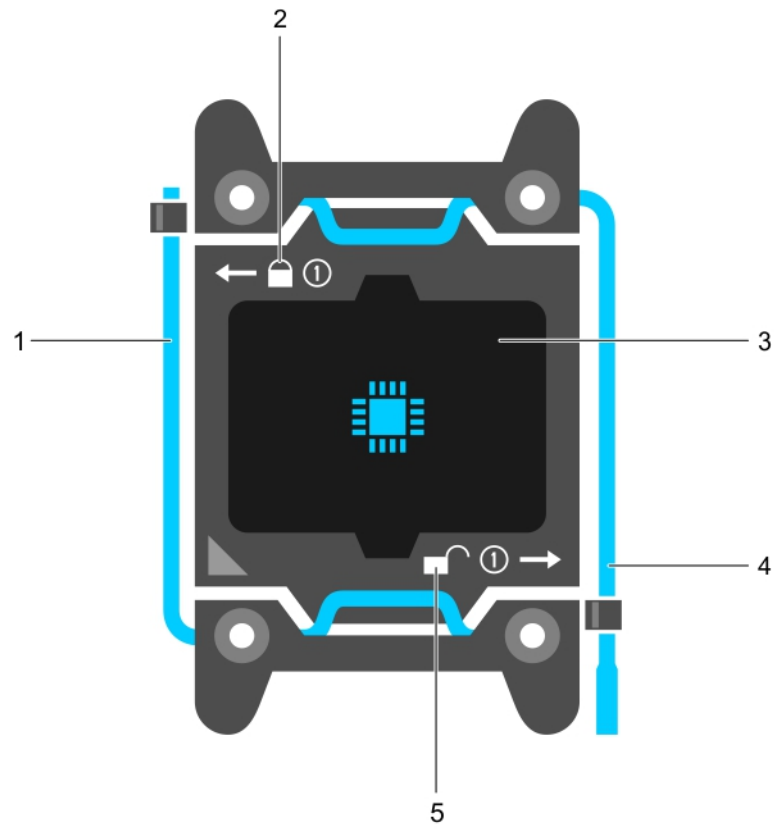

Figure 20. Processor shield

- 1. *close first* socket release lever
- 3. processor
- 5. unlock icon

- 2. lock icon
- 4. *open first* socket release lever

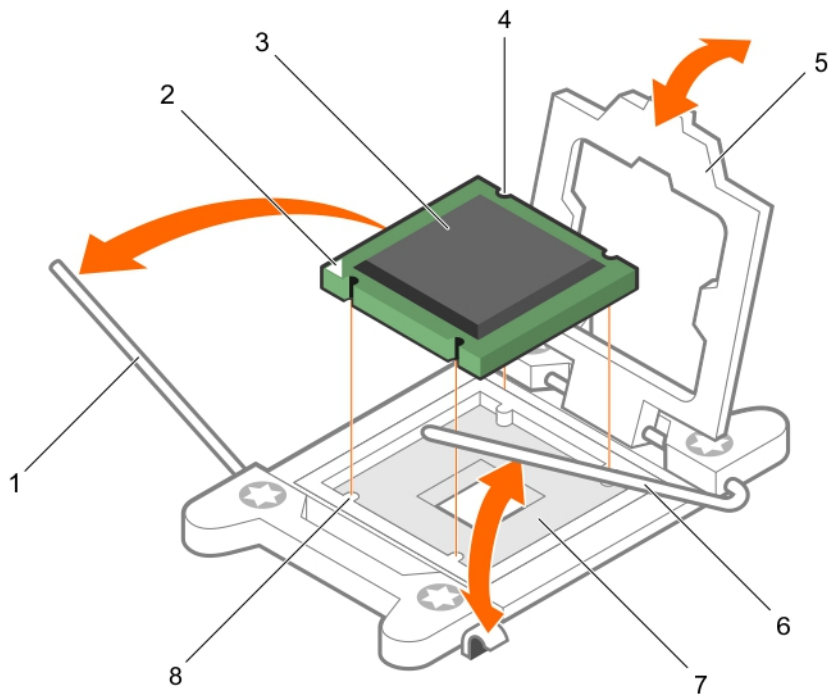

Figure 21. Removing a processor

- | | |
|--|---|
| 1. <i>close first</i> socket-release lever | 2. pin-1 indicator of processor |
| 3. processor | 4. slot (4) |
| 5. processor shield | 6. <i>open first</i> socket-release lever |
| 7. socket | 8. socket keys (4) |

Next steps

1. Replace the processor(s).
2. Install the heat sink.
3. Reinstall the cooling shroud.
4. Follow the procedure listed in the After working inside your system section.

Related tasks

- [Before working inside your system](#)
- [Removing an expansion card from expansion card riser 2 or 3](#)
- [Removing the cooling shroud](#)
- [Removing a heat sink](#)
- [Installing a processor](#)
- [Installing a heat sink](#)
- [Installing the cooling shroud](#)
- [Installing an expansion card into the expansion card riser 2 or 3](#)
- [After working inside your system](#)

Related reference

- [Safety instructions](#)

Installing a processor

Prerequisites

CAUTION: Many repairs may only be done by a certified service technician. You should only perform troubleshooting and simple repairs as authorized in your product documentation, or as directed by the online or telephone service and support team. Damage due to servicing that is not authorized by Dell is not covered by your warranty. Read and follow the safety instructions that are shipped with your product.

1. Follow the safety guidelines listed in the Safety instructions section.
2. Follow the procedure listed in the Before working inside your system section.
3. Keep the Phillips #2 screwdriver ready.
4. If you are upgrading your system, download the latest system BIOS version from [Dell.com/support](https://www.dell.com/support) and follow the instructions included in the compressed download file to install the update on your system.

NOTE: You can also update the system BIOS by using the Dell Lifecycle Controller.

5. Remove the cooling shroud.

NOTE: If applicable, close the expansion card latch on the cooling shroud to release the full length card.

6. If connected, disconnect the cables from expansion card(s).
7. If installed, remove the expansion card riser.

NOTE: The heat sink and processor are too hot to touch for some time after the system has been powered down. Allow the heat sink and processor to cool down before handling them.



CAUTION: Never remove the heat sink from a processor unless you intend to remove the processor. The heat sink is necessary to maintain proper thermal conditions.

NOTE: If you are installing a single processor, it must be installed in socket CPU1.

Steps

1. Unpack the new processor.

NOTE: If the processor has previously been used in a system, remove any remaining thermal grease from the processor by using a lint-free cloth.



2. Locate the processor socket.
3. If applicable, remove the socket protective cap.
4. Release the *open first* socket-release lever near the unlock icon  by pushing the lever down and out from under the tab.
5. Similarly, release the *close first* socket-release lever near the lock icon  by pushing the lever down and out from under the tab. Lift the lever 90 degrees upward.
6. Hold the tab near the lock symbol on the processor shield and lift it up and out of the way.

CAUTION: Positioning the processor incorrectly can permanently damage the system board or the processor. Be careful not to bend the pins in the socket.

CAUTION: While removing or reinstalling the processor, wipe your hands of any contaminants. Contaminants on the processor pins such as thermal grease or oil can damage the processor.

7. Align the processor with the socket keys.

CAUTION: Do not use force to seat the processor. When the processor is positioned correctly, it engages easily into the socket.

8. Align the pin-1 indicator of the processor with the triangle on the system board.
9. Place the processor on the socket such that the slots on the processor align with the socket keys.
10. Close the processor shield.
11. Lower the *close first* socket-release lever near the lock icon  and push it under the tab to lock it.
12. Similarly, lower the *open first* socket-release lever near the unlock icon  and push it under the tab to lock it.

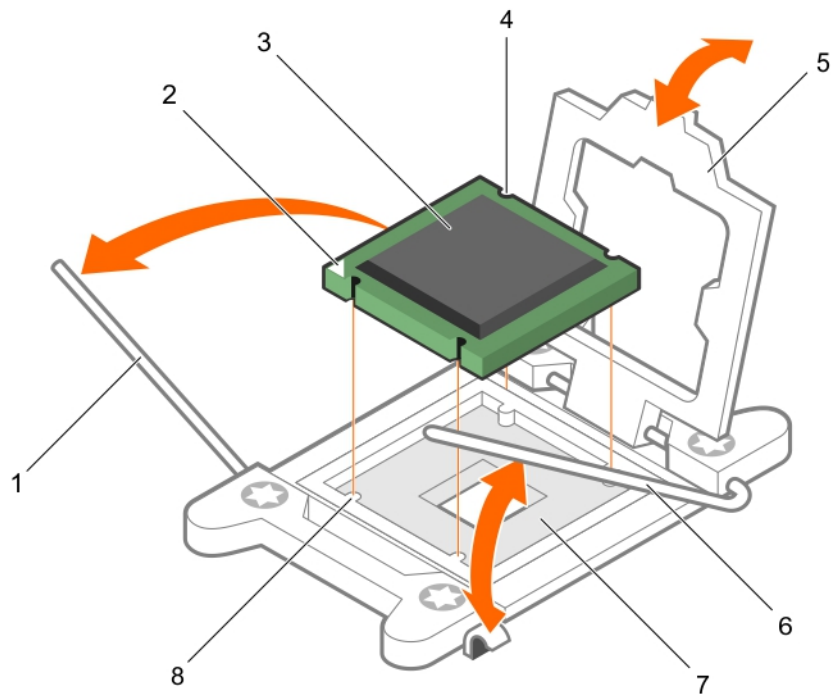

Figure 22. Installing a processor

- | | |
|---------------------------|----------------------------------|
| 1. socket-release lever 1 | 2. pin-1 corner of the processor |
| 3. processor | 4. slot (4) |
| 5. processor shield | 6. socket-release lever 2 |
| 7. processor socket | 8. tab (4) |

Next steps

i **NOTE:** Ensure that you install the heat sink after you install the processor. The heat sink is necessary to maintain proper thermal conditions.

1. Install the heat sink.
2. If removed, reinstall the PCIe expansion card riser.
3. If disconnected, reconnect the cables to the expansion card(s).
4. While booting, press F2 to enter System Setup and verify that the processor information matches the new system configuration.
5. Run the system diagnostics to verify that the new processor operates correctly.

Related tasks

[Before working inside your system](#)

[Removing an expansion card from expansion card riser 2 or 3](#)

[Removing an expansion card from the expansion card riser 1](#)

[Removing the cooling shroud](#)

[Removing a heat sink](#)

[Installing a heat sink](#)

[Installing the cooling shroud](#)

[Installing an expansion card into the expansion card riser 2 or 3](#)

[Installing an expansion card into the expansion card riser 1](#)

[After working inside your system](#)

Related reference

[Safety instructions](#)

Installing a heat sink

Prerequisites

CAUTION: Many repairs may only be done by a certified service technician. You should only perform troubleshooting and simple repairs as authorized in your product documentation, or as directed by the online or telephone service and support team. Damage due to servicing that is not authorized by Dell is not covered by your warranty. Read and follow the safety instructions that are shipped with your product.

1. Follow the safety guidelines listed in the Safety instructions section.
2. Follow the procedure listed in the Before working inside your system section.
3. Keep the Phillips #2 screwdriver ready.
4. Install the processor.

NOTE: If you are installing a single processor, it must be installed in socket CPU1.

Steps

1. If you are using an existing heat sink, remove the thermal grease from the heat sink by using a clean lint-free cloth.
2. Use the thermal grease syringe included with your processor kit to apply the grease in a thin spiral on the top of the processor.

CAUTION: Applying too much thermal grease can result in excess grease coming in contact with and contaminating the processor socket.

NOTE: The thermal grease syringe is intended for one-time use only. Dispose of the syringe after you use it.

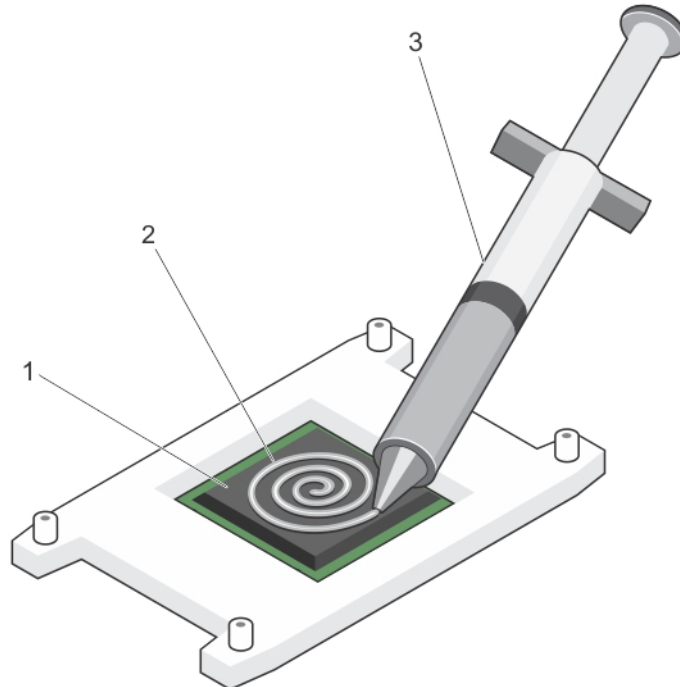

Figure 23. Applying thermal grease on the top of the processor

- a. processor
 - b. thermal grease
 - c. thermal grease syringe
3. Place the heat sink onto the processor.

4. Tighten one of the four screws to secure the heat sink to the system board.
5. Tighten the screw diagonally opposite to the first screw you have tightened.

i **NOTE:** Do not over-tighten the heat sink retention screws when installing the heat sink. To prevent over-tightening, tighten the retention screw until resistance is felt, and stop after the screw is seated. The screw tension should not be more than 6 in-lb (6.9 kg-cm).

6. Repeat the procedure for the remaining two screws.

Next steps

1. Follow the procedure listed in the After working inside your system section.
2. While booting, press F2 to enter System Setup and verify that the processor information matches the new system configuration.
3. Run the system diagnostics to verify that the new processor operates correctly.

PCIe card holder

The PCIe card holder can be extended to support a full length PCIe card. This will prevent any damage to the card that may occur due to its length.

Removing the PCIe card holder

Prerequisites

1. Follow the safety guidelines listed in the Safety instructions section.
2. Follow the procedure listed in the Before working inside your system section.
3. If installed, remove the full-length PCIe card.

△ CAUTION: Many repairs may only be done by a certified service technician. You should only perform troubleshooting and simple repairs as authorized in your product documentation, or as directed by the online or telephone service and support team. Damage due to servicing that is not authorized by Dell is not covered by your warranty. Read and follow the safety instructions that are shipped with your product.

△ CAUTION: Do not use your system without the PCIe card holder installed. The PCIe card holder is necessary to ensure proper system cooling.

Steps

1. Press the release tab and slide the card holder toward the back of the chassis to release the PCIe card holder from the chassis.
2. Lift the PCIe card holder out of the chassis.

i **NOTE:** To ensure proper system cooling, you must replace the PCIe card holder.

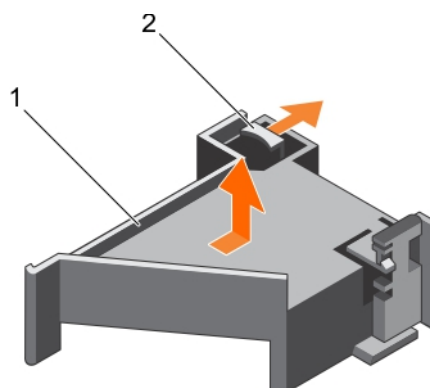

Figure 24. Removing the PCIe card holder

- a. PCIe card holder
- b. release tab

Next steps

1. Replace the PCIe card holder.
2. If removed, install the full-length PCIe card.
3. Follow the procedure listed in the After working inside your system section.

Related tasks

[Before working inside your system](#)

[Removing an expansion card from expansion card riser 2 or 3](#)

[Installing the PCIe card holder](#)

[Installing an expansion card into the expansion card riser 2 or 3](#)

[After working inside your system](#)

Related reference

[Safety instructions](#)

Installing the PCIe card holder

Prerequisites

1. Follow the safety guidelines listed in the Safety instructions section.
2. Follow the procedure listed in the Before working inside your system section.

CAUTION: Many repairs may only be done by a certified service technician. You should only perform troubleshooting and simple repairs as authorized in your product documentation, or as directed by the online or telephone service and support team. Damage due to servicing that is not authorized by Dell is not covered by your warranty. Read and follow the safety instructions that are shipped with your product.

CAUTION: Do not use your system without the PCIe card holder installed. The PCIe card holder is necessary to ensure proper system cooling.

Steps

1. Align the PCIe card holder with the notches and tabs on the power supply unit cage.
2. Press the release tab and slide the PCIe card holder toward the front of the chassis until firmly seated.

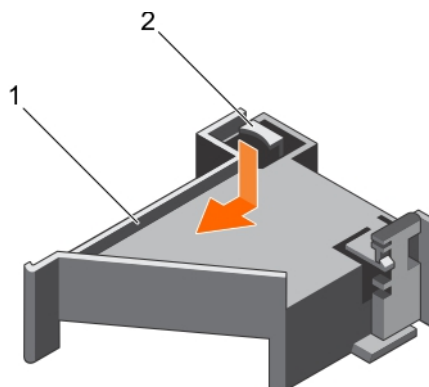

Figure 25. Installing the PCIe card holder

- a. PCIe card holder
- b. release tab

Next steps

1. If applicable, replace the full-length PCIe card.
2. Follow the procedure listed in the After working inside your system section.

Related tasks

Before working inside your system

Installing an expansion card into the expansion card riser 2 or 3

After working inside your system

Related reference

Safety instructions

Opening and closing the PCIe card holder latch

Prerequisites

1. Follow the safety guidelines listed in Safety instructions section.
2. Follow the procedure listed in the Before working inside your system section.

CAUTION: Many repairs may only be done by a certified service technician. You should only perform troubleshooting and simple repairs as authorized in your product documentation, or as directed by the online or telephone service and support team. Damage due to servicing that is not authorized by Dell is not covered by your warranty. Read and follow the safety instructions that are shipped with your product.

Steps

1. To open the PCIe card holder latch, press the release tab.
2. To close the PCIe card holder latch, rotate the latch clockwise until it locks.

NOTE: Before installing a full-length PCIe card, the PCIe card holder latch must be closed. When the full-length PCIe card is installed, open the PCIe card holder latch. Before removing the full-length PCIe card, you must close the PCIe card holder latch.

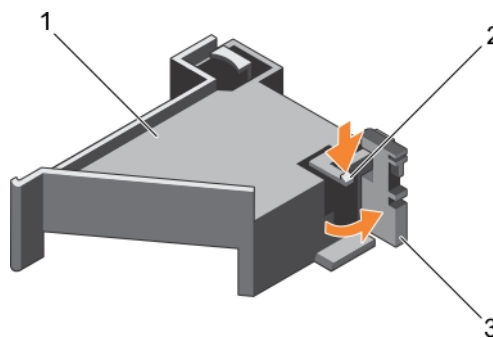

Figure 26. Opening the PCIe card holder latch

- a. PCIe card holder
- b. release tab
- c. PCIe card holder latch

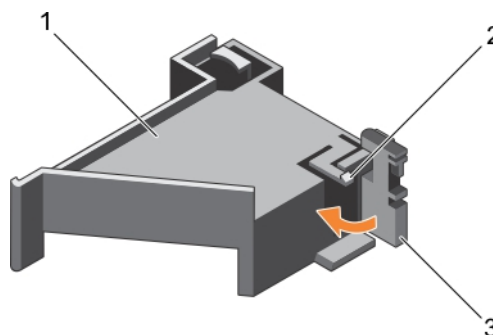

Figure 27. Closing the PCIe card holder latch

- a. PCIe card holder

- b. release tab
- c. PCIe card holder latch

Next steps

Follow the procedure listed in the After working inside your system section.

Cable retention bracket

Cable retention bracket provides support to the installed cables. The cable retention bracket also helps to prevent the cables from moving out of place, which may result in loose connections and reduced air flow inside the server.

Removing the cable retention bracket

Prerequisites

1. Follow the safety guidelines listed in the Safety instructions section.
2. Follow the procedure listed in the Before working inside your system section.
3. If installed, remove the cooling shroud.
4. Remove the PCIe card holder.
5. Remove all cables routed through the cable retention bracket.

CAUTION: Many repairs may only be done by a certified service technician. You should only perform troubleshooting and simple repairs as authorized in your product documentation, or as directed by the online or telephone service and support team. Damage due to servicing that is not authorized by Dell is not covered by your warranty. Read and follow the safety instructions that are shipped with your product.

Steps

1. Pull the tab to release it from the notch and slide the cable retention bracket toward the front of the chassis to release it from the chassis.
2. Lift the cable retention bracket out of the chassis.

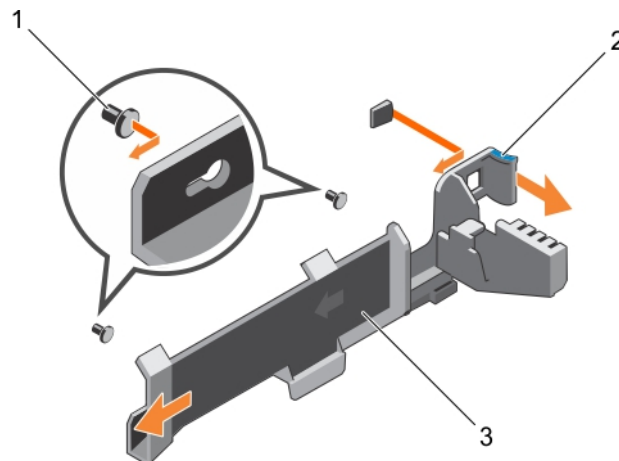

Figure 28. Removing the cable retention bracket

- a. alignment pin (2)
- b. tab
- c. cable retention bracket

Next steps

1. Install the cable retention bracket and reconnect all cables routed through the cable retention bracket.
2. If removed, install the PCIe card holder.
3. If removed, install the cooling shroud.
4. Follow the procedure listed in the After working inside your system section.

Related tasks

- [Before working inside your system](#)
- [Removing the cooling shroud](#)
- [Removing the PCIe card holder](#)
- [Installing the cable retention bracket](#)
- [Installing the cooling shroud](#)
- [Installing the PCIe card holder](#)
- [After working inside your system](#)

Related reference

- [Safety instructions](#)

Installing the cable retention bracket

Prerequisites

1. Follow the safety guidelines listed in the Safety instructions section.
2. Follow the procedure listed in the Before working inside your system section.
3. If installed, remove the cooling shroud.
4. Remove the PCIe card holder.

CAUTION: Many repairs may only be done by a certified service technician. You should only perform troubleshooting and simple repairs as authorized in your product documentation, or as directed by the online or telephone service and support team. Damage due to servicing that is not authorized by Dell is not covered by your warranty. Read and follow the safety instructions that are shipped with your product.

Steps

1. Align the cable retention bracket with the alignment pins on the chassis.
2. Slide the cable retention bracket along the chassis wall until the tab clicks and locks the keyhole slots.
3. Place all cables to be routed in the cable retention bracket.

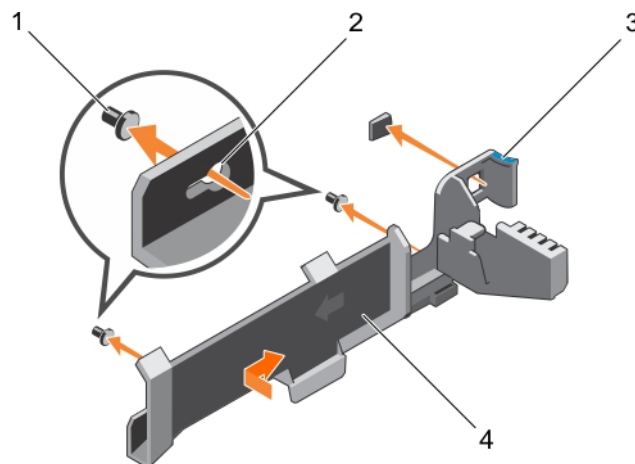

Figure 29. Installing the cable retention bracket

- | | |
|----------------------|----------------------------|
| 1. alignment pin (2) | 2. keyhole slot |
| 3. tab | 4. cable retention bracket |

Next steps

1. Install the PCIe card holder.
2. Install the cooling shroud.
3. Follow the procedure listed in the After working inside your system section.

Related tasks

[Before working inside your system](#)
[Removing the cooling shroud](#)
[Removing the PCIe card holder](#)
[Installing the cooling shroud](#)
[Installing the PCIe card holder](#)
[After working inside your system](#)

Related reference

[Safety instructions](#)

Integrated storage controller card

Your system includes a dedicated expansion card slot on the system board for an integrated controller card. The integrated storage controller card provides the integrated storage subsystem for the internal hard drives in your system. The controller supports SAS and SATA hard drives and also enables you to set up the hard drives in RAID configurations. The RAID configurations depend on the version of the storage controller included with your system.

Removing the integrated storage controller card

Prerequisites

 **CAUTION:** Many repairs may only be done by a certified service technician. You should only perform troubleshooting and simple repairs as authorized in your product documentation, or as directed by the online or telephone service and support team. Damage due to servicing that is not authorized by Dell is not covered by your warranty. Read and follow the safety instructions that are shipped with your product.

1. Follow the safety guidelines listed in the Safety instructions section.
2. Follow the procedure listed in the Before working inside your system section.
3. Remove the cooling shroud.
4. Remove the expansion card riser 1.
5. Keep the Phillips #2 screwdriver ready.

Steps

1. Loosen the screws that secure the integrated storage controller cable to the integrated storage controller card connector on the system board.
2. Lift the integrated storage controller cable away from the integrated storage controller.
3. Lift one end of the card and angle it to disengage the card from the integrated storage controller card holder on the system board.
4. Lift the card out of the system.

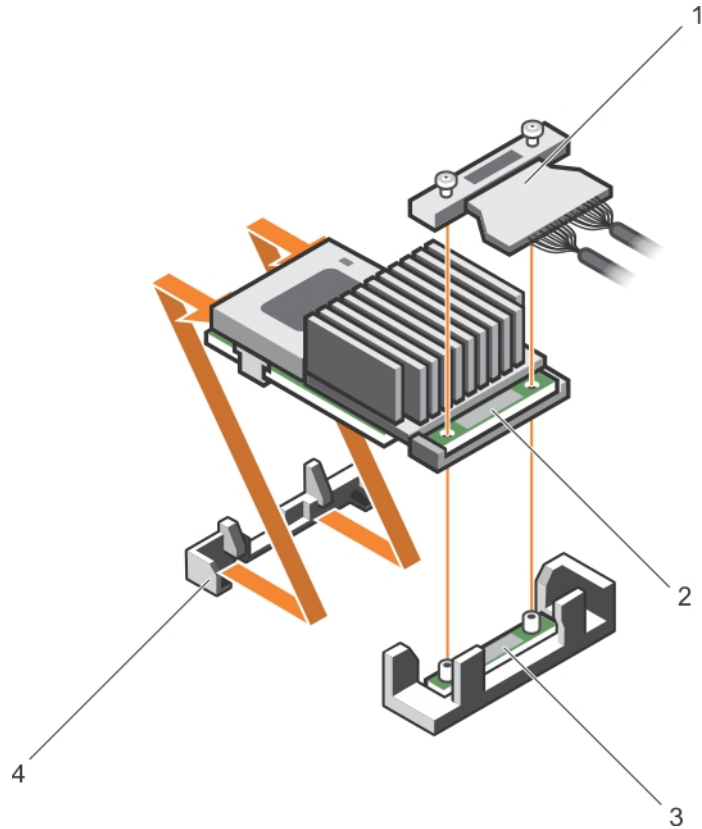

Figure 30. Removing the integrated storage controller card

- | | |
|---|--|
| 1. integrated storage controller cable | 2. integrated storage controller card |
| 3. integrated storage controller card connector on the system board | 4. integrated storage controller card holder board |

Next steps

1. Install the expansion card riser 1.
2. Install the cooling shroud.
3. Installing the integrated storage controller card.
4. Follow the procedure listed in the After working inside your system section.

Related tasks

- [Before working inside your system](#)
- [Removing the cooling shroud](#)
- [Removing expansion card risers](#)
- [Installing expansion card risers](#)
- [Installing the cooling shroud](#)
- [After working inside your system](#)

Related reference

- [Safety instructions](#)

Installing the integrated storage controller card

Prerequisites

CAUTION: Many repairs may only be done by a certified service technician. You should only perform troubleshooting and simple repairs as authorized in your product documentation, or as directed by the online or telephone service and

support team. Damage due to servicing that is not authorized by Dell is not covered by your warranty. Read and follow the safety instructions that are shipped with your product.

1. Follow the safety guidelines listed in the Safety instructions section.
2. Follow the procedure listed in the Before working inside your system section.
3. Remove the cooling shroud.
4. Remove the expansion card riser 1.
5. Keep the Phillips #2 screwdriver ready.

Steps

1. Align the end of the integrated storage controller card with the controller card connector on the system board.
2. Lower the connector side of the integrated storage controller card into the integrated storage controller card connector on the system board.

i NOTE: Ensure that the tabs on the system board align with the screw holes on the integrated storage controller card.

3. Align the screws on the integrated storage controller card cable with the screw holes on the connector.
4. Tighten the screws to secure the integrated storage controller card cable with the integrated storage controller card connector on the system board.

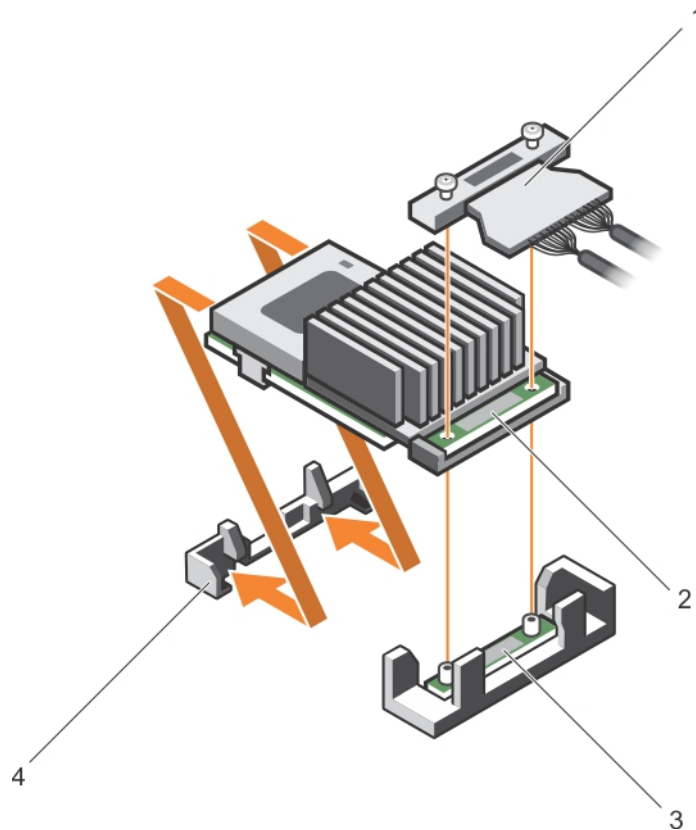

Figure 31. Installing the integrated storage controller card

- | | |
|---|--|
| 1. integrated storage controller cable | 2. integrated storage controller card |
| 3. integrated storage controller card connector on the system board | 4. integrated storage controller card holder |

Next steps

1. Install the expansion card riser 1.
2. Install the cooling shroud.
3. Follow the procedure listed in the After working inside your system section.

Related tasks

[Before working inside your system](#)
[Removing the cooling shroud](#)
[Removing expansion card risers](#)
[Installing expansion card risers](#)
[Installing the cooling shroud](#)
[After working inside your system](#)

Related reference

[Safety instructions](#)

Expansion cards and expansion card riser

An expansion card in the server is an add-on card that can be inserted into an expansion slot on the system board or riser card to add enhanced functionality to the system through the expansion bus.

NOTE: A System Event Log (SEL) event is logged if an expansion card riser is unsupported or missing. It does not prevent your system from turning on and no BIOS POST message or F1/F2 pause is displayed.

Expansion card installation guidelines

Depending on your system configuration, the following PCI Express (PCIe) generation 3 expansion cards are supported:

Table 33. Supported expansion cards

PCIe slot	Riser	Processor connection	Height	Length	Link width	Slot width
1	1	Processor 2	Low Profile	Half Length	x8	x16
2	1	Processor 2	Low Profile	Half Length	x8	x16
3	1	Processor 2	Low Profile	Half Length	x8	x16
4	2	Processor 2	Full Height	Full Length	x16	x16
5	2	Processor 1	Full Height	Full Length	x8	x16
6	3 (alternate)	Processor 1	Full Height	Full Length	x16	x16

NOTE: To use PCIe slots 1 through 4 on the risers 1 and 2, both the processors must be installed.

NOTE: The expansion card slots are not hot-swappable.

The following table provides guidelines for installing expansion cards to ensure proper cooling and mechanical fit. The expansion cards with the highest priority should be installed first using the slot priority indicated. All the other expansion cards should be installed in the card priority and slot priority order.

NOTE: Ensure that the 100 G OPA x16 card is installed in slot 6 (x16 PCIe) on the alternate riser 3.

Removing an expansion card from expansion card riser 2 or 3

Prerequisites

CAUTION: Many repairs may only be done by a certified service technician. You should only perform troubleshooting and simple repairs as authorized in your product documentation, or as directed by the online or telephone service and support team. Damage due to servicing that is not authorized by Dell is not covered by your warranty. Read and follow the safety instructions that are shipped with your product.

CAUTION: When removing the NV-RAM card ensure that, after powering down the system gracefully from the GUI or CLI, both green and amber LEDs on the card are off.

1. Follow the safety guidelines listed in the Safety instructions section.
2. Follow the procedure listed in the Before working inside your system section.
3. When removing a card from riser 3, ensure that the PCIe holder latch is closed.

Steps

1. Disconnect any cables connected to the expansion card.
2. Lift the expansion card latch out of the guide slot.
3. Hold the expansion card by its edges, and remove it from the expansion card connector.
4. If you are removing the card permanently, install a metal filler bracket over the empty expansion slot opening and close the expansion card latch.

NOTE: You must install a filler bracket over an empty expansion card slot to maintain Federal Communications Commission (FCC) certification of the system. The brackets also keep dust and dirt out of the system and aid in proper cooling and airflow inside the system.

5. Install the expansion card latch into the slot.
6. Close the expansion card locking tabs.

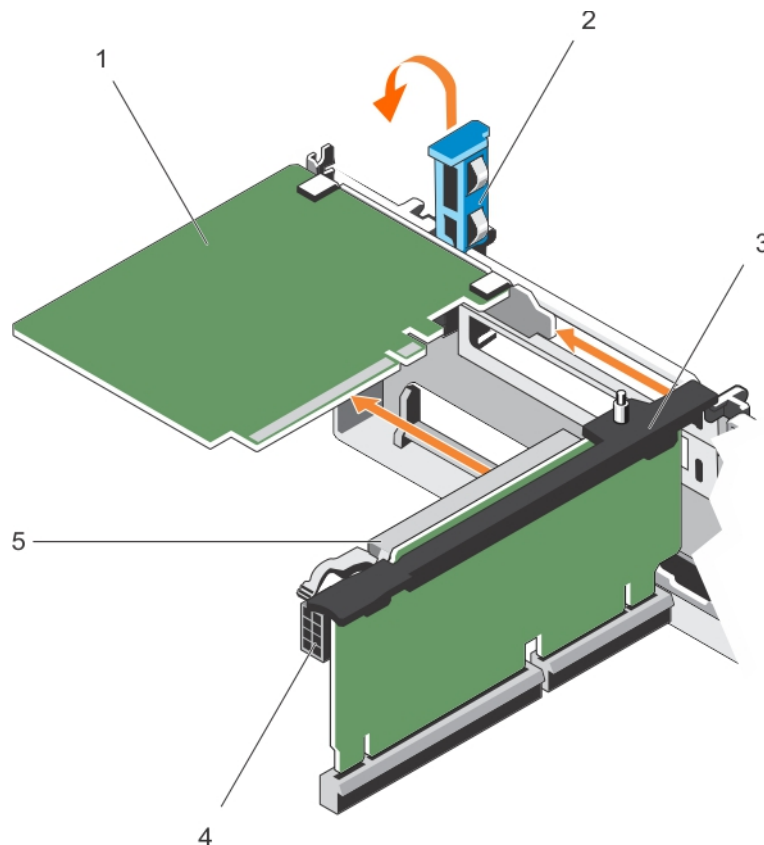

Figure 32. Removing an expansion card from expansion card riser 2 or 3

- | | |
|-----------------------------|------------------------------------|
| 1. expansion card | 2. expansion card latch |
| 3. expansion card riser | 4. power connector (for GPU cards) |
| 5. expansion card connector | |

Next steps

1. Install an expansion card into the expansion card riser.
2. Follow the procedure listed in the After working inside your system section.

Related tasks

[Before working inside your system](#)

[Installing an expansion card into the expansion card riser 2 or 3](#)

[After working inside your system](#)

Related reference

[Safety instructions](#)

Installing an expansion card into the expansion card riser 2 or 3

Prerequisites

1. Follow the safety guidelines listed in the Safety instructions section.
2. Follow the procedure listed in the Before working inside your system section.

 **CAUTION:** Many repairs may only be done by a certified service technician. You should only perform troubleshooting and simple repairs as authorized in your product documentation, or as directed by the online or telephone service and support team. Damage due to servicing that is not authorized by Dell is not covered by your warranty. Read and follow the safety instructions that are shipped with your product.

Steps

1. Unpack the expansion card and prepare it for installation.
For instructions, see the documentation accompanying the card.
2. Lift the expansion card latch and remove the filler bracket.
3. Holding the card by its edges, position the card so that the connector on the expansion card aligns with the expansion card connector on the riser.
4. Insert the card-edge connector firmly into the expansion card connector until the card is fully seated.
5. Press the touch points to open the expansion card locking tabs.
6. Close the expansion card latch.
7. If applicable, connect the cables to the expansion card.

 **NOTE:** When installing a GPU card on riser 2 or riser 3 (default), connect the GPU card power cable to the power connector on the riser.

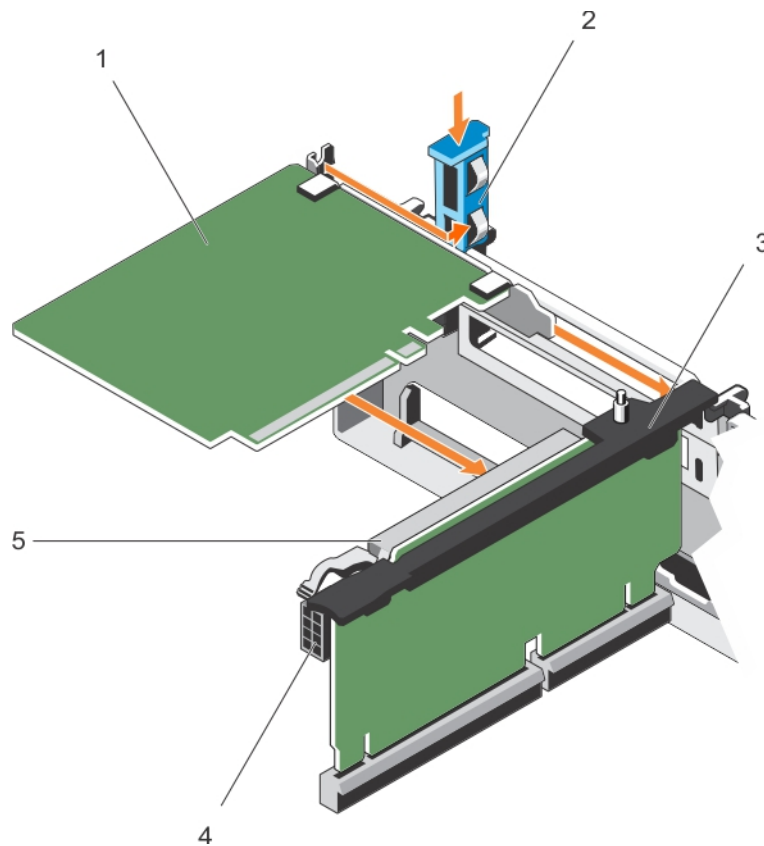

Figure 33. Installing an expansion card into the expansion card riser 2 or 3

- | | |
|-----------------------------|------------------------------------|
| 1. expansion card | 2. expansion card latch |
| 3. expansion card riser | 4. power connector (for GPU cards) |
| 5. expansion card connector | |

Next steps

1. Follow the procedure listed in the After working inside your system section.
2. Install any device drivers required for the card as described in the documentation for the card.

Related tasks

[Before working inside your system](#)

[After working inside your system](#)

Related reference

[Safety instructions](#)

Removing an expansion card from the expansion card riser 1

Prerequisites

CAUTION: Many repairs may only be done by a certified service technician. You should only perform troubleshooting and simple repairs as authorized in your product documentation, or as directed by the online or telephone service and support team. Damage due to servicing that is not authorized by Dell is not covered by your warranty. Read and follow the safety instructions that are shipped with your product.

1. Follow the safety guidelines listed in the Safety instructions section.
2. Follow the procedure listed in the Before working inside your system section.

3. Disconnect any cables connected to the expansion card.
4. Remove the expansion card riser.

NOTE: The expansion card riser 1 can be used only when both the processors are installed.

Steps

1. Press tab A and rotate the latch clockwise.
2. Press tab B and rotate the latch downward.
3. Remove the expansion card from the expansion card riser 1.
4. If you are removing the card permanently, install a metal filler bracket over the empty expansion slot opening, and then close the expansion card latch.

NOTE: You must install a filler bracket over an empty expansion card slot to maintain Federal Communications Commission (FCC) certification of the system. The brackets also keep dust and dirt out of the system and aid in proper cooling and airflow inside the system.

5. Close the latches of tab A and tab B.

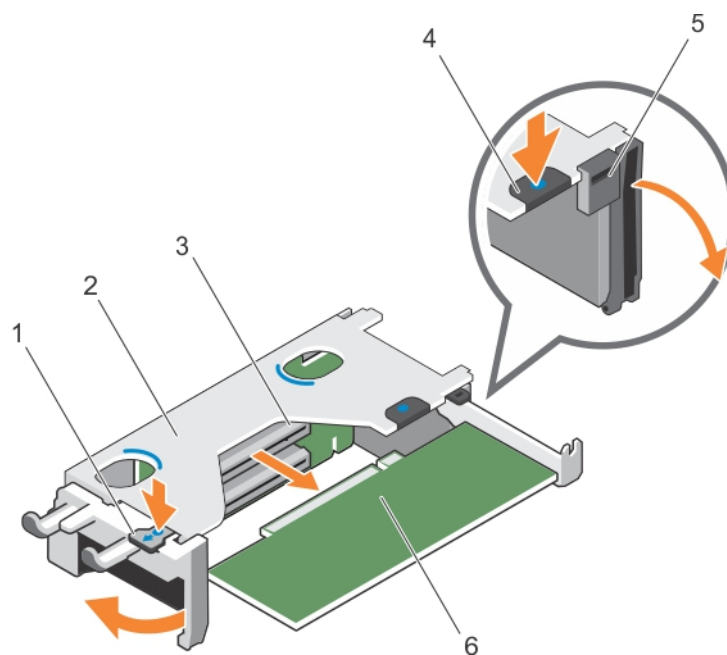

Figure 34. Removing an expansion card from expansion card riser 1

- | | |
|-----------------------------|--------------------------------|
| 1. tab A | 2. expansion card riser 1 cage |
| 3. expansion card connector | 4. tab B |
| 5. latch | 6. expansion card |

Next steps

1. Install the expansion card.
2. Install the expansion card riser.
3. Follow the procedure listed in the After working inside your system section.

Related tasks

[Before working inside your system](#)

[Removing expansion card risers](#)

[Installing an expansion card into the expansion card riser 1](#)

[Installing expansion card risers](#)

[After working inside your system](#)

Related reference

[Safety instructions](#)

Installing an expansion card into the expansion card riser 1

Prerequisites

1. Follow the safety guidelines listed in the Safety instructions section.
2. Follow the procedure listed in the Before working inside your system section.
3. Remove the expansion card riser.

CAUTION: Many repairs may only be done by a certified service technician. You should only perform troubleshooting and simple repairs as authorized in your product documentation, or as directed by the online or telephone service and support team. Damage due to servicing that is not authorized by Dell is not covered by your warranty. Read and follow the safety instructions that are shipped with your product.

NOTE: The expansion card riser 1 can be used only when both the processors are installed.

Steps

1. Unpack the expansion card and prepare it for installation.
For instructions, see the documentation accompanying the card.
2. Press tab A and rotate the latch clockwise.
3. Press tab B and rotate the latch down.
4. Holding the card by its edges, position the card so that the card-edge connector aligns with the expansion card connector.
5. Insert the card-edge connector firmly into the expansion card connector until the card is fully seated.
6. Close the latches of tab A and tab B.

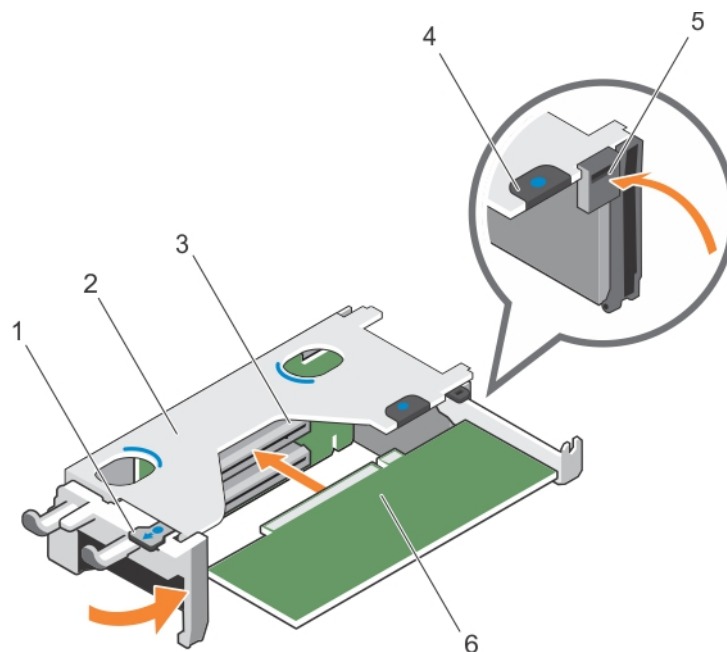

Figure 35. Installing an expansion card into the expansion card riser 1

- | | |
|-----------------------------|--------------------------------|
| 1. tab A | 2. expansion card riser 1 cage |
| 3. expansion card connector | 4. tab B |
| 5. latch | 6. expansion card |

Next steps

1. Install the expansion card riser.
2. If applicable, connect any cables to the expansion card.

3. Follow the procedure listed in the After working inside your system section.
4. Install any device drivers required for the card as described in the documentation for the card.

Related tasks

- [Before working inside your system](#)
- [Removing expansion card risers](#)
- [Installing expansion card risers](#)
- [After working inside your system](#)

Related reference

- [Safety instructions](#)

Removing the riser 1 blank

Prerequisites

CAUTION: Many repairs may only be done by a certified service technician. You should only perform troubleshooting and simple repairs as authorized in your product documentation, or as directed by the online or telephone service and support team. Damage due to servicing that is not authorized by Dell is not covered by your warranty. Read and follow the safety instructions that are shipped with your product.

1. Follow the safety guidelines listed in the Safety instructions section.
2. Follow the procedure listed in the Before working inside your system section.
3. Remove the expansion card riser.

Steps

Press the tabs on the riser 1 blank and push the riser 1 blank out of the chassis.

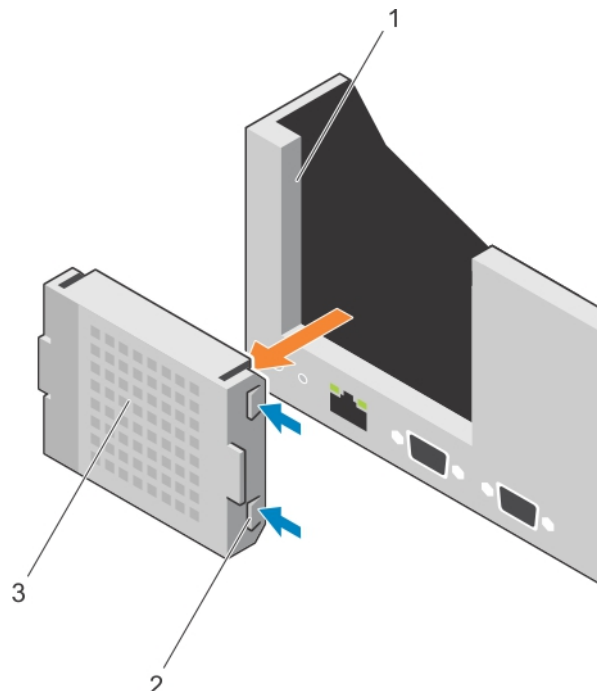

Figure 36. Removing the riser 1 blank

- a. slot on the chassis
- b. tab (2)
- c. riser 1 blank

Next steps

1. Install the expansion card risers.
2. Follow the procedure listed in the After working inside your system section.

Related tasks

[Before working inside your system](#)

[Removing expansion card risers](#)

[Installing expansion card risers](#)

[After working inside your system](#)

Related reference

[Safety instructions](#)

Installing the riser 1 blank

Prerequisites

CAUTION: Many repairs may only be done by a certified service technician. You should only perform troubleshooting and simple repairs as authorized in your product documentation, or as directed by the online or telephone service and support team. Damage due to servicing that is not authorized by Dell is not covered by your warranty. Read and follow the safety instructions that are shipped with your product.

Steps

To install the riser 1 blank, align the blank with the slot on the chassis and insert it into the chassis until it clicks into place.

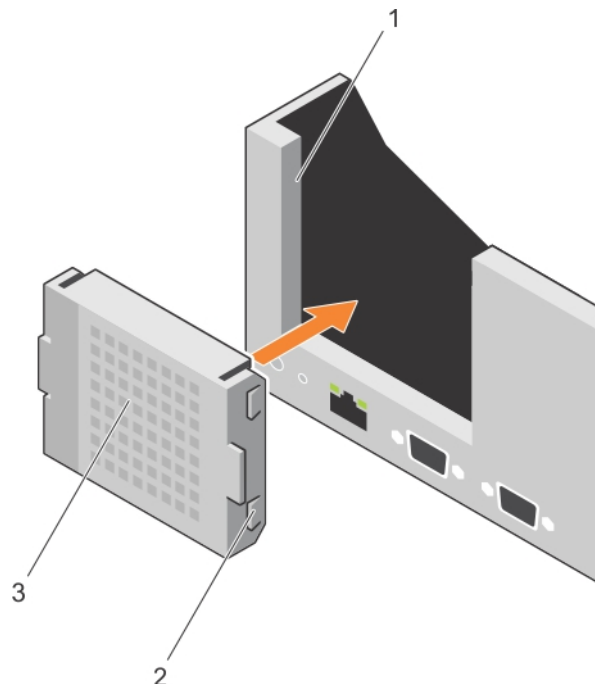

Figure 37. Installing the riser 1 blank

- a. slot on the chassis
- b. tab (2)
- c. riser 1 blank

Next steps

1. Install the expansion card risers.
2. Follow the procedure listed in the After working inside your system section.

Related tasks

- [Before working inside your system](#)
- [Removing expansion card risers](#)
- [Installing expansion card risers](#)
- [After working inside your system](#)

Related reference

- [Safety instructions](#)

Removing expansion card risers

Prerequisites

CAUTION: Many repairs may only be done by a certified service technician. You should only perform troubleshooting and simple repairs as authorized in your product documentation, or as directed by the online or telephone service and support team. Damage due to servicing that is not authorized by Dell is not covered by your warranty. Read and follow the safety instructions that are shipped with your product.

1. Follow the safety guidelines listed in the Safety instructions section.
2. Follow the procedure listed in the Before working inside your system section.
3. If installed, remove any expansion card installed on risers 2 and 3.

NOTE: The expansion card riser 1 can be used only when both the processors are installed.

Steps

1. Holding the slots on the expansion card riser, lift the riser from the riser connector on the system board.
2. To remove expansion card risers 2 and 3, hold the edges of the expansion card riser, and lift the riser from the riser connector on the system board.

NOTE: To ensure proper system cooling, the riser 1 blank must be installed in the riser 1 slot. Remove the riser 1 blank only if you are installing riser 1.

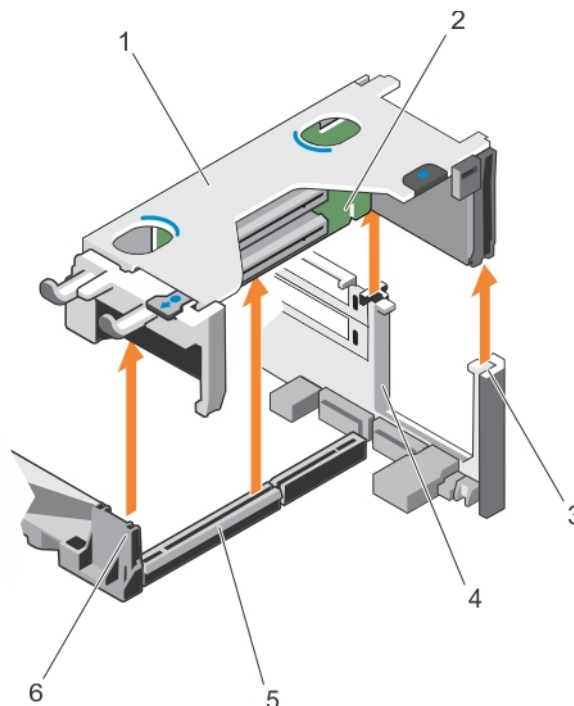

Figure 38. Removing the expansion card riser 1

1. expansion card riser 1 cage
2. expansion card riser 1

- 3. riser guide-back (right)
- 4. riser guide-back (left)
- 5. expansion card riser 1 connector
- 6. riser guide-front

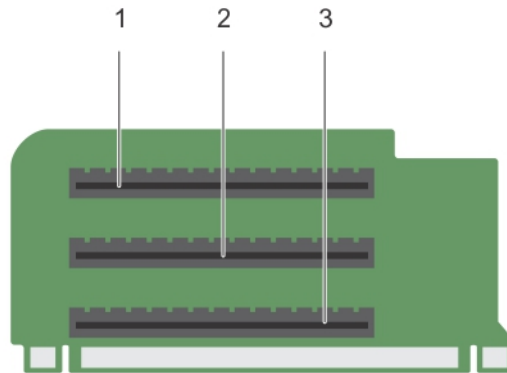

Figure 39. Identifying connectors on the expansion card riser 1

- a. expansion card slot 1
- b. expansion card slot 2
- c. expansion card slot 3

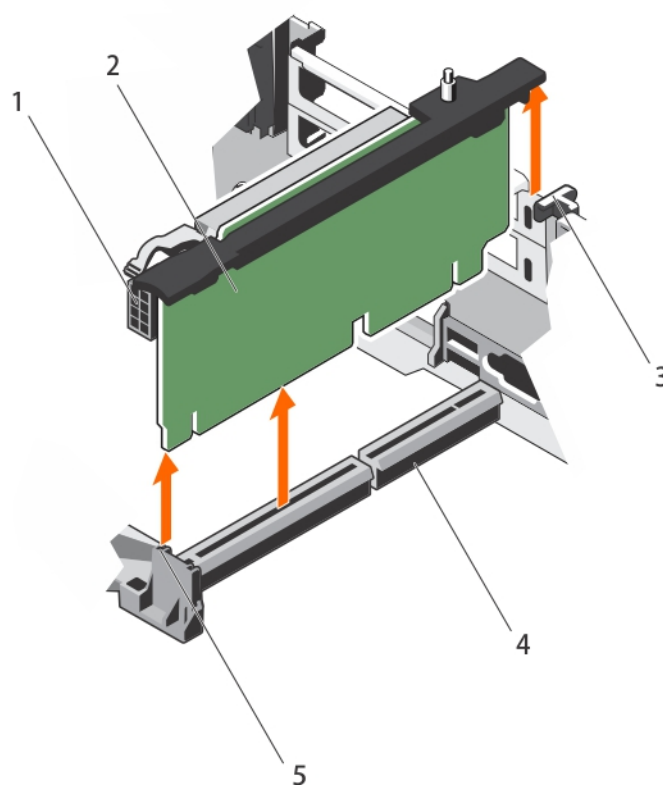

Figure 40. Removing the expansion card riser 2

- 1. power connector (for GPU cards)
- 2. expansion card riser 2
- 3. riser guide-back
- 4. expansion card riser 2 connector
- 5. riser guide-front

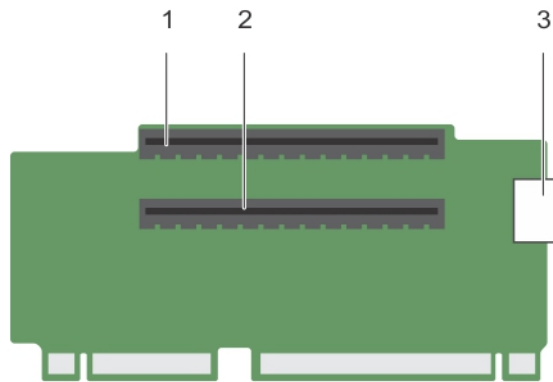

Figure 41. Identifying connectors on the expansion card riser 2

- a. expansion card slot 4
- b. expansion card slot 5
- c. power connector (for GPU cards)

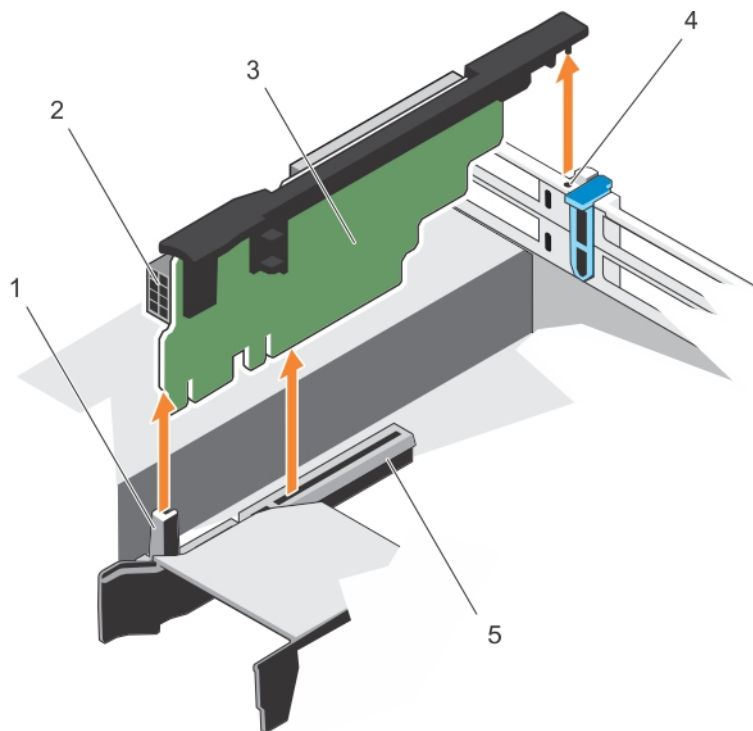

Figure 42. Removing the expansion card riser 3

- 1. riser guide-front
- 2. power connector (for GPU cards)
- 3. expansion card riser 3
- 4. riser guide-back
- 5. expansion card riser 3 connector

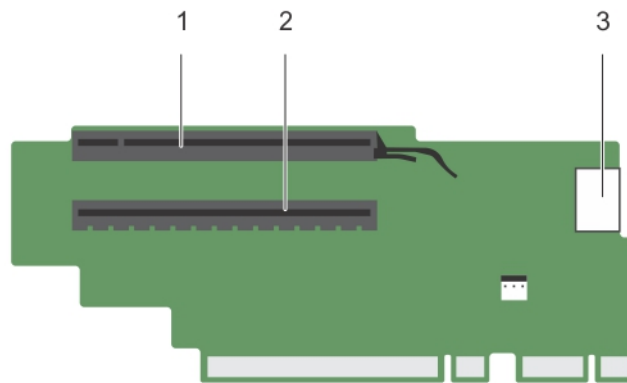

Figure 43. Identifying connectors on the expansion card riser 3 (default)

- a. expansion card slot 6
- b. expansion card slot 7
- c. power connector (for GPU cards)

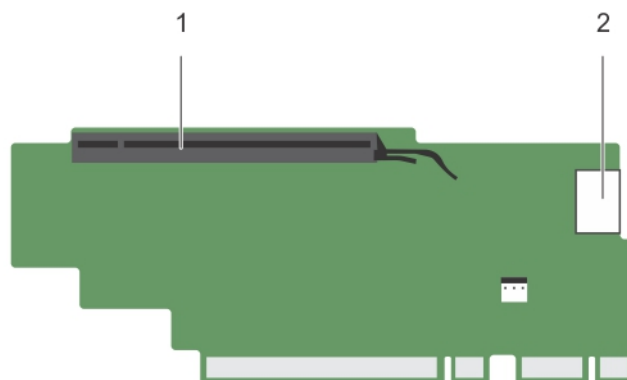

Figure 44. Identifying connectors on the expansion card riser 3 (alternate)

- a. expansion card slot 6
- b. power connector (for GPU cards)

Next steps

1. If removed, install an expansion card on the riser.
2. If applicable, replace the expansion card riser.
3. Follow the procedure listed in the After working inside your system section.

Related tasks

- [Before working inside your system](#)
- [Removing an expansion card from expansion card riser 2 or 3](#)
- [Removing an expansion card from the expansion card riser 1](#)
- [Installing an expansion card into the expansion card riser 1](#)
- [Installing an expansion card into the expansion card riser 2 or 3](#)
- [After working inside your system](#)

Related reference

[Safety instructions](#)

Installing expansion card risers

Prerequisites

1. Follow the safety guidelines listed in the Safety instructions section.
2. Follow the procedure listed in the Before working inside your system section.
3. If removed, install the expansion card(s) into the expansion card riser 1.

CAUTION: Many repairs may only be done by a certified service technician. You should only perform troubleshooting and simple repairs as authorized in your product documentation, or as directed by the online or telephone service and support team. Damage due to servicing that is not authorized by Dell is not covered by your warranty. Read and follow the safety instructions that are shipped with your product.

Steps

1. Align the expansion card riser with the connectors and the riser guides on the system board.
2. Lower the expansion card riser into place until the expansion card riser is fully seated in the connector.

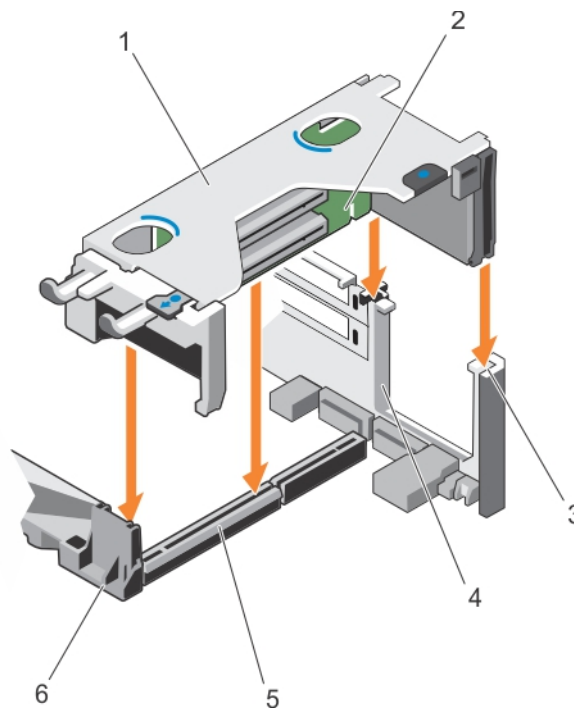

Figure 45. Installing the expansion card riser 1

- | | |
|-------------------------------------|----------------------------|
| 1. expansion card riser 1 cage | 2. expansion card riser 1 |
| 3. riser guide-back (right) | 4. riser guide-back (left) |
| 5. expansion card riser 1 connector | 6. riser guide-front |

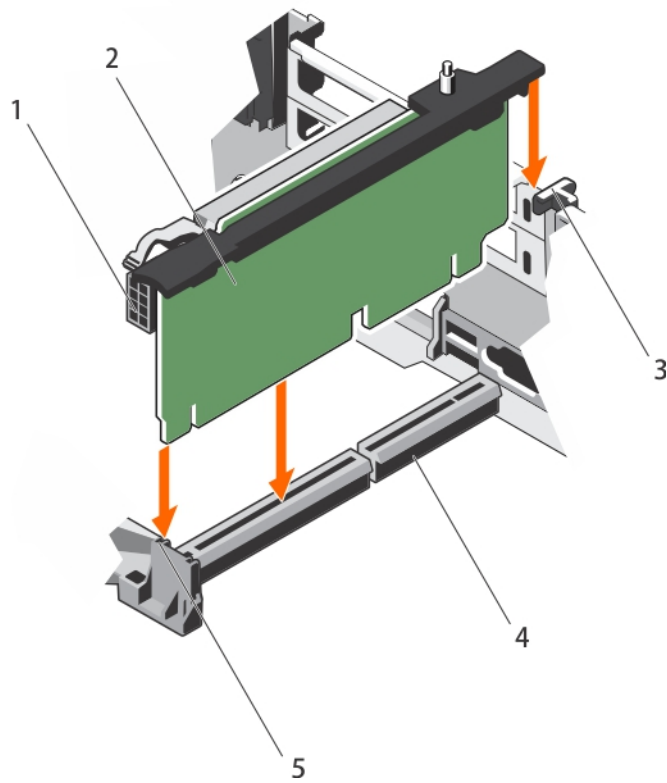

Figure 46. Installing the expansion card riser 2

- | | |
|------------------------------------|-------------------------------------|
| 1. power connector (for GPU cards) | 2. expansion card riser 2 |
| 3. riser guide-back | 4. expansion card riser 2 connector |
| 5. riser guide-front | |

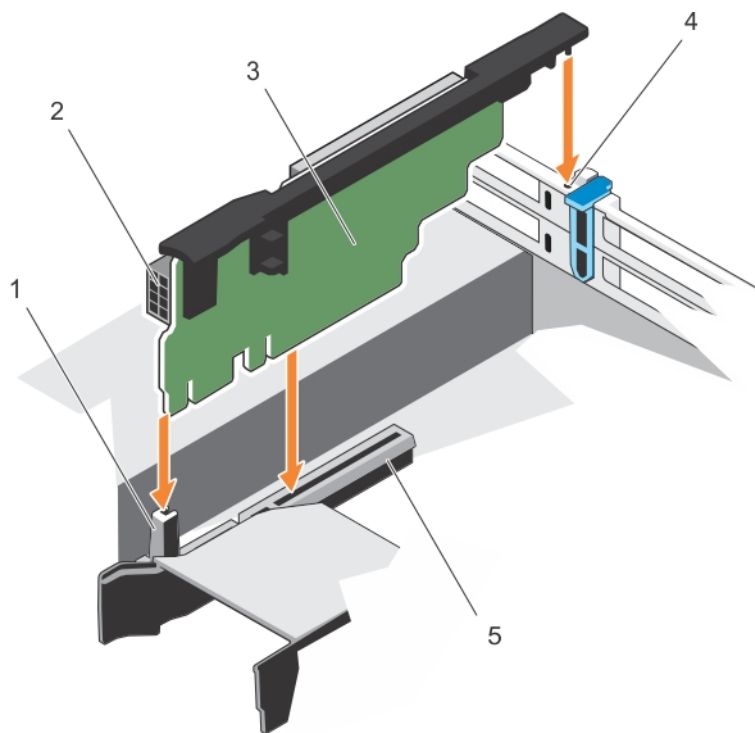

Figure 47. Installing the expansion card riser 3

- | | |
|---------------------------|------------------------------------|
| 1. riser guide-front | 2. power connector (for GPU cards) |
| 3. expansion card riser 3 | 4. riser guide-back |

5. expansion card riser 3 connector

Next steps

1. Install the expansion card(s) into the expansion card risers 2 or 3.
2. Follow the procedure listed in the After working inside your system section.
3. Install any device drivers required for the card as described in the documentation for the card.

Internal dual SD module (optional)

The Internal Dual SD module (IDSMD) provides you with a redundant SD card solution. You can configure the IDSMD for storage or as the OS boot partition. The IDSMD card offers the following features:

- Dual card operation — maintains a mirrored configuration by using SD cards in both the slots and provides redundancy.
 - **NOTE:** When the Redundancy option is set to Mirror Mode in the Integrated Devices screen of System Setup, the information is replicated from one SD card to another.
- Single card operation — single card operation is supported, but without redundancy.

Removing an internal SD card

Prerequisites

1. Follow the safety guidelines listed in the Safety instructions section.
2. Follow the procedure listed in the Before working inside your system section.

CAUTION: Many repairs may only be done by a certified service technician. You should only perform troubleshooting and simple repairs as authorized in your product documentation, or as directed by the online or telephone service and support team. Damage due to servicing that is not authorized by Dell is not covered by your warranty. Read and follow the safety instructions that are shipped with your product.

NOTE: Temporarily label each SD card with its corresponding slot number before removal. Re-install the SD card(s) into the corresponding slots.

Steps

Locate the SD card slot on the internal dual SD module and press the card to release it from the slot.

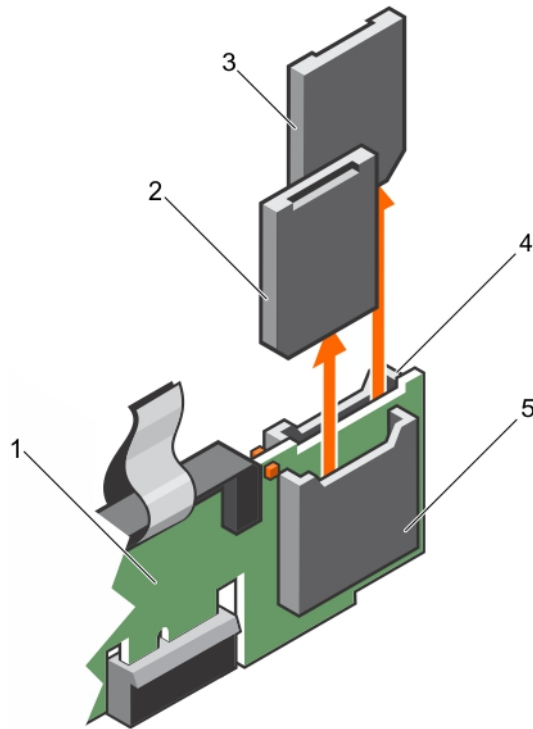

Figure 48. Removing an internal SD card

- | | |
|-------------------|-------------------|
| 1. IDSDM | 2. SD card 1 |
| 3. SD card 2 | 4. SD card slot 2 |
| 5. SD card slot 1 | |

Next steps

Follow the procedure listed in the After working inside your system section.

Related tasks

- [Before working inside your system](#)
- [After working inside your system](#)

Related reference

- [Safety instructions](#)

Installing an internal SD card

Prerequisites

1. Follow the safety guidelines listed in the Safety instructions section.
2. Follow the procedure listed in the Before working inside your system section.

CAUTION: Many repairs may only be done by a certified service technician. You should only perform troubleshooting and simple repairs as authorized in your product documentation, or as directed by the online or telephone service and support team. Damage due to servicing that is not authorized by Dell is not covered by your warranty. Read and follow the safety instructions that are shipped with your product.

NOTE: To use an SD card with your system, ensure that the Internal SD Card Port is enabled in System Setup.

NOTE: Temporarily label each SD card with its corresponding slot number before removal. Re-install the SD card(s) into the corresponding slots.

Steps

1. Locate the SD card connector on the internal dual SD module. Orient the SD card appropriately and insert the contact-pin end of the card into the slot.

i **NOTE:** The slot is keyed to ensure correct insertion of the card.

2. Press the card into the card slot to lock it into place.

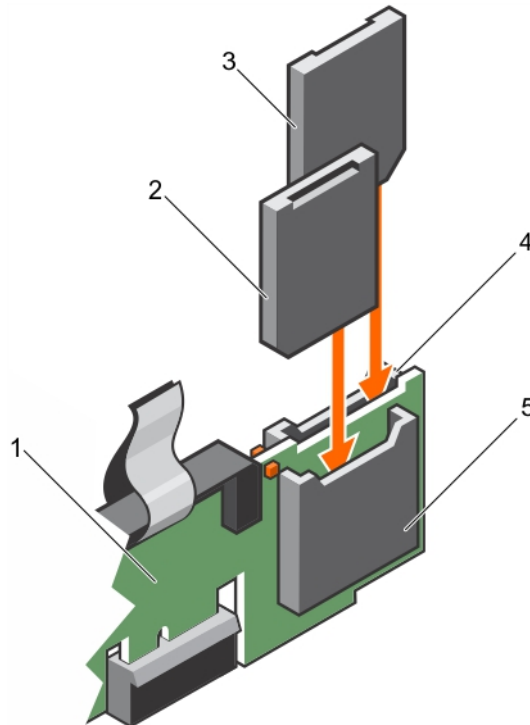

Figure 49. Installing an internal SD card

- | | |
|-------------------|-------------------|
| 1. IDSDM | 2. SD card 2 |
| 3. SD card 1 | 4. SD card slot 1 |
| 5. SD card slot 2 | |

Next steps

Follow the procedure listed in the After working inside your system section.

Related tasks

[Before working inside your system](#)

[After working inside your system](#)

Related reference

[Safety instructions](#)

Removing the optional internal dual SD module

Prerequisites

⚠ CAUTION: Many repairs may only be done by a certified service technician. You should only perform troubleshooting and simple repairs as authorized in your product documentation, or as directed by the online or telephone service and support team. Damage due to servicing that is not authorized by Dell is not covered by your warranty. Read and follow the safety instructions that are shipped with your product.

1. Follow the safety guidelines listed in the Safety instructions section.
2. Follow the procedure listed in the Before working inside your system section.

- If installed, remove the SD cards.

NOTE: Temporarily label each SD card with its corresponding slot number before removal. Reinstall the SD cards into the corresponding slots.

Steps

- Locate the internal dual SD module (IDSDM) on the system board. To locate the internal dual SD module connector, see the System board connectors section.
- Holding the pull tab, lift the IDSDM out of the system.

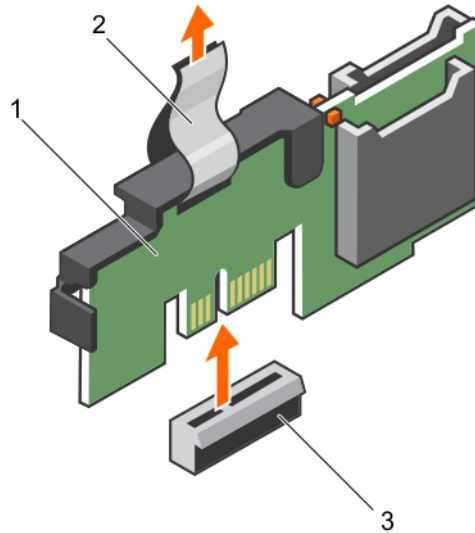

Figure 50. Removing the internal dual SD module (IDSDM)

- IDSDM
- pull tab
- IDSDM connector

The following table describes the IDSDM indicator codes:

Table 34. IDSDM indicator codes

Convention	IDSDM indicator code	Description
A	Green	Indicates that the card is online.
B	Flashing green	Indicates rebuild or activity.
C	Flashing amber	Indicates card mismatch or that the card has failed.
D	Amber	Indicates that the card is offline, has failed, or is write protected.
E	Not lit	Indicates that the card is missing or is booting.

Next steps

- Install the IDSDM.
- If removed, install the SD cards.
- Follow the procedure listed in the After working inside your system section.

Related tasks

[Before working inside your system](#)

[Removing an internal SD card](#)

[Installing the optional internal dual SD module](#)

[After working inside your system](#)

Related reference

[Safety instructions](#)

[System board jumpers and connectors](#)

Installing the optional internal dual SD module

Prerequisites

CAUTION: Many repairs may only be done by a certified service technician. You should only perform troubleshooting and simple repairs as authorized in your product documentation, or as directed by the online or telephone service and support team. Damage due to servicing that is not authorized by Dell is not covered by your warranty. Read and follow the safety instructions that are shipped with your product.

1. Follow the safety guidelines listed in the Safety instructions section.
2. Follow the procedure listed in the Before working inside your system section.

NOTE: Temporarily label each SD card with its corresponding slot before removal.

Steps

1. Locate the internal dual SD module (IDSDM) connector on the system board. To locate the IDSDM connector, see the System board connectors section.
2. Align the IDSDM with the connector on the system board.
3. Push the IDSDM until it is firmly seated on the system board.

Next steps

1. Install the SD cards.

NOTE: Re-install the SD cards into the same slots based on the labels you had marked on the cards during removal.

2. Follow the procedure listed in the After working inside your system section.

Related tasks

[Before working inside your system](#)

[Installing an internal SD card](#)

[After working inside your system](#)

Related reference

[Safety instructions](#)

Network daughter card

The Network daughter card (NDC) is a small, removable mezzanine card. The NDC provides you with the flexibility of choosing different network connectivity options, for example—4 x 1GbE, 2 x 10GbE and 2 x Converged Network Adapter.

Removing the network daughter card

Prerequisites

1. Follow the safety guidelines listed in the Safety instructions section.
2. Follow the procedure listed in the Before working inside your system section.
3. If installed, remove expansion card(s) from the expansion card riser 2.
4. Keep the Phillips #1 screwdriver ready.

CAUTION: Many repairs may only be done by a certified service technician. You should only perform troubleshooting and simple repairs as authorized in your product documentation, or as directed by the online or telephone service and support team. Damage due to servicing that is not authorized by Dell is not covered by your warranty. Read and follow the safety instructions that are shipped with your product.

support team. Damage due to servicing that is not authorized by Dell is not covered by your warranty. Read and follow the safety instructions that are shipped with your product.

Steps

1. Loosen the captive screws that secure the network daughter card (NDC) to the system board.
2. Hold the NDC by the edges on either side of the touch point and lift the card to remove it from the connector on the system board.
3. Slide the NDC away from the back of the system until the Ethernet connectors are clear of the slot in the back panel.
4. Lift the NDC out of the chassis.

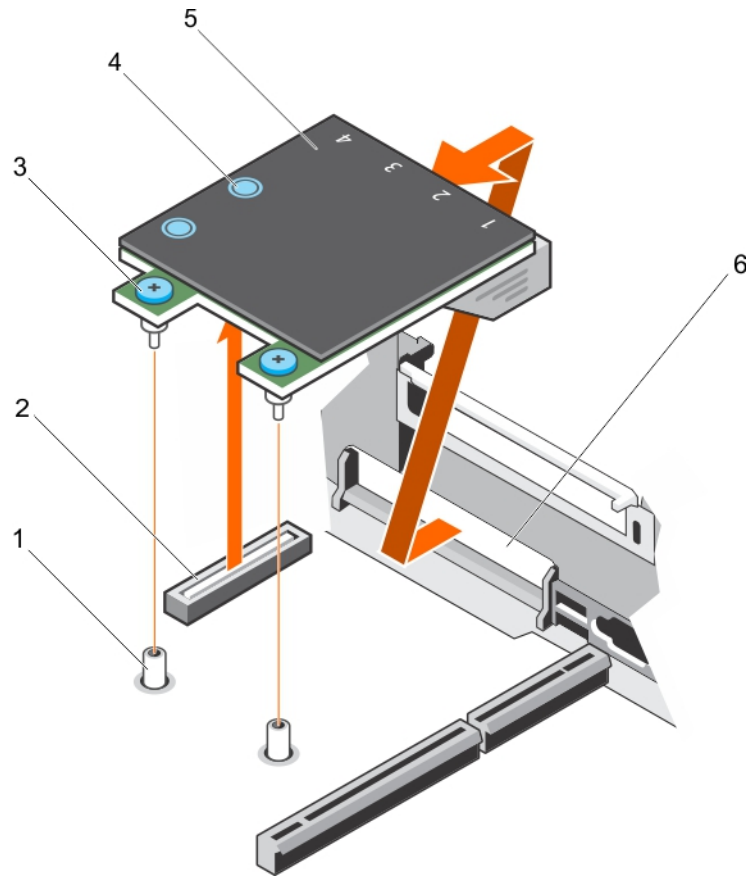

Figure 51. Removing the NDC

- | | |
|--------------------------------|--|
| 1. captive screw socket (2) | 2. connector on the system board |
| 3. captive screw (2) | 4. touch point (2) |
| 5. network daughter card (NDC) | 6. back panel slot for Ethernet connectors |

Next steps

1. Install the NDC.
2. If removed, install the expansion card(s) on the expansion card riser 2.
3. Follow the procedure listed in the After working inside your system section.

Related tasks

[Before working inside your system](#)

[Removing an expansion card from expansion card riser 2 or 3](#)

[Installing an expansion card into the expansion card riser 2 or 3](#)

[Installing the network daughter card](#)

[After working inside your system](#)

Related reference

[Safety instructions](#)

Installing the network daughter card

Prerequisites

1. Follow the safety guidelines listed in the Safety instructions section.
2. Follow the procedure listed in the Before working inside your system section.
3. If applicable, remove the expansion card(s) in the expansion card riser 2.
4. Keep the Phillips #1 screwdriver ready.

CAUTION: Many repairs may only be done by a certified service technician. You should only perform troubleshooting and simple repairs as authorized in your product documentation, or as directed by the online or telephone service and support team. Damage due to servicing that is not authorized by Dell is not covered by your warranty. Read and follow the safety instructions that are shipped with your product.

Steps

1. Orient the network daughter card (NDC) so that the Ethernet connectors fit through the slot in the back panel.
2. Align the captive screws on the card with the captive screw sockets on the system board.
3. Press the touch points on the card until the card connector is firmly seated on the system board connector.
4. Tighten the captive screws to secure the NDC to the system board.

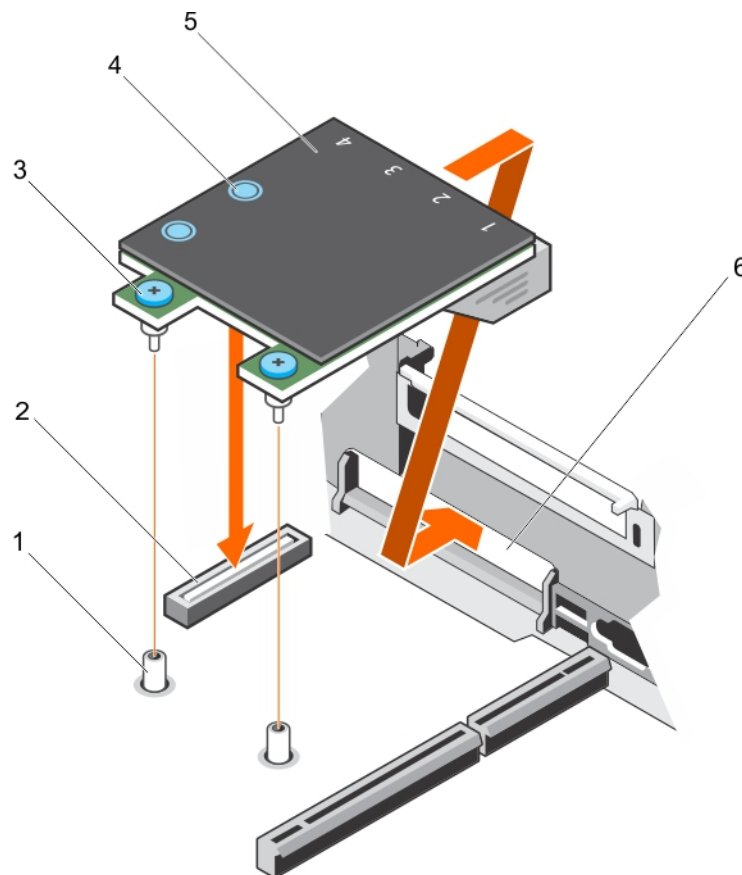

Figure 52. Installing the NDC

- | | |
|--------------------------------|--|
| 1. captive screw socket (2) | 2. connector on the system board |
| 3. captive screw (2) | 4. touch point (2) |
| 5. network daughter card (NDC) | 6. back panel slot for Ethernet connectors |

Next steps

1. If applicable, install the expansion card(s) in the expansion card riser 2.
2. Follow the procedure listed in the After working inside your system section.

Related tasks

[Before working inside your system](#)

[Removing an expansion card from expansion card riser 2 or 3](#)

[Installing an expansion card into the expansion card riser 2 or 3](#)

[After working inside your system](#)

Related reference

[Safety instructions](#)

Internal USB memory key (optional)

An optional USB memory key installed inside your system can be used as a boot device, security key, or mass storage device.

To boot from the USB memory key, configure the USB memory key with a boot image and then specify the USB memory key in the boot sequence in System Setup.

The internal USB port must be enabled in **Internal USB Port** option in the **Integrated Devices** screen of **System Setup**.

NOTE: To locate the internal USB port (INT_USB) on the system board, see the **System board jumpers and connectors** section.

Replacing the optional internal USB memory key

Prerequisites

CAUTION: Many repairs may only be done by a certified service technician. You should only perform troubleshooting and simple repairs as authorized in your product documentation, or as directed by the online or telephone service and support team. Damage due to servicing that is not authorized by Dell is not covered by your warranty. Read and follow the safety instructions that are shipped with your product.

1. Follow the safety guidelines listed in the Safety instructions section.
2. Follow the procedure listed in the Before working inside your system section.

Steps

1. Locate the USB port or USB memory key on the system board.
To locate the USB port, see the System board jumpers and connectors section.
2. If installed, remove the USB memory key from the USB port.

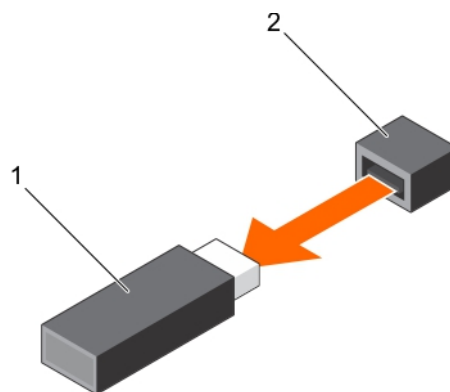

Figure 53. Removing the internal USB memory key

- a. USB memory key
 - b. USB port
3. Insert the replacement USB memory key into the USB port.

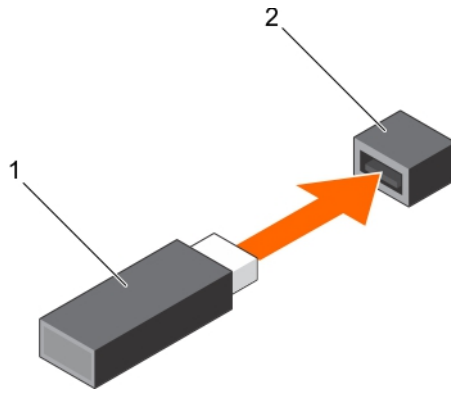

Figure 54. Installing the internal USB memory key

- a. USB memory key
- b. USB port

Next steps

1. Follow the procedure listed in the After working inside your system section.
2. While booting, press F2 to enter System Setup and verify that the system detects the USB memory key.

Related tasks

- [Before working inside your system](#)
- [After working inside your system](#)

Related reference

- [Safety instructions](#)
- [System board jumpers and connectors](#)

System battery

The system battery is used for low-level system functions like powering the real-time clock and storing the computer's BIOS settings.

Replacing the system battery

Prerequisites

i **NOTE:** There is a danger of a new battery exploding if it is incorrectly installed. Replace the battery only with the same or equivalent type recommended by the manufacturer. For more information, see the safety information that shipped with your system.

△ **CAUTION:** Many repairs may only be done by a certified service technician. You should only perform troubleshooting and simple repairs as authorized in your product documentation, or as directed by the online or telephone service and support team. Damage due to servicing that is not authorized by Dell is not covered by your warranty. Read and follow the safety instructions that are shipped with your product.

1. Follow the safety guidelines listed in the Safety instructions section.
2. Follow the procedure listed in the Before working inside your system section.
3. Remove the cooling shroud.

Steps

1. Locate the battery socket. For more information, see the Jumpers and connectors section.

△ **CAUTION:** To avoid damage to the battery connector, you must firmly support the connector while installing or removing a battery.

2. Place your finger between the securing tabs at the negative side of the battery connector and lift the battery out of the socket.

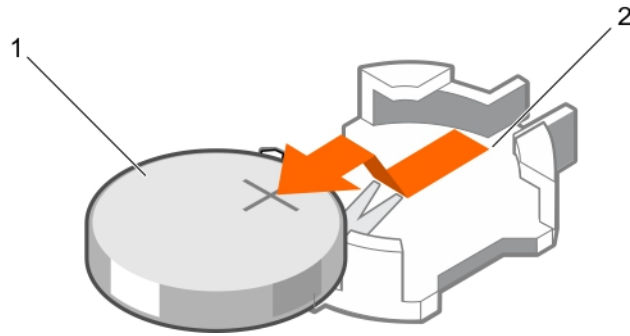

Figure 55. Removing the system battery

- a. system battery
 - b. system battery slot
3. To install a new system battery, hold the battery with the "+" facing up and slide it under the securing tabs.
 4. Press the battery into the connector until it snaps into place.

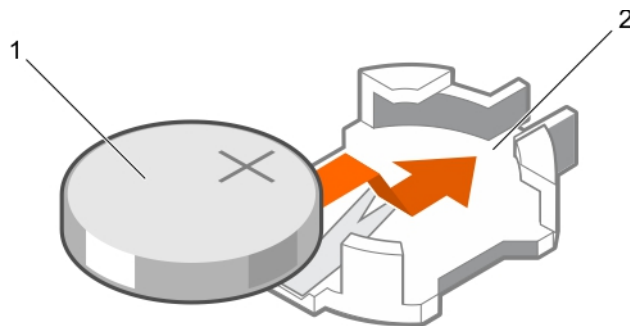

Figure 56. Installing the system battery

- a. system battery
- b. system battery slot

Next steps

1. Install the cooling shroud.
2. Follow the procedure listed in the After working inside your system section.
3. While booting, press F2 to enter System Setup and ensure the battery is operating properly.
4. Enter the correct time and date in the System Setup **Time** and **Date** fields.
5. Exit System Setup.

Related tasks

- [Before working inside your system](#)
- [Removing the cooling shroud](#)
- [Installing the cooling shroud](#)
- [After working inside your system](#)

Related reference

- [Safety instructions](#)
- [System board jumpers and connectors](#)

Power supply units (PSU)

Your system supports two 1100 W AC PSU modules.

CAUTION: For AC PSUs, use only PSUs with the Extended Power Performance (EPP) label on the back. Mixing PSUs from previous generations of systems can result in a PSU mismatch condition or failure to turn on.

 **NOTE:** Titanium PSU is nominally rated for 200 V AC to 240 V AC input only.

 **NOTE:** When two identical PSUs are installed, power supply redundancy (1+1 – with redundancy or 2+0 – without redundancy) is configured in system BIOS. In redundant mode, power is supplied to the system equally from both PSUs when Hot Spare is disabled. When Hot Spare is enabled, one of the PSUs will be put into standby when system utilization is low in order to maximize efficiency.

 **NOTE:** If two PSUs are used, they must be of the same maximum output power.

Hot spare feature

Your system supports the hot spare feature that significantly reduces the power overhead associated with power supply unit (PSU) redundancy.

When the hot spare feature is enabled, one of the redundant PSUs is switched to the sleep state. The active PSU supports 100 percent of the load, thus operating at higher efficiency. The PSU in the sleep state monitors output voltage of the active PSU. If the output voltage of the active PSU drops, the PSU in the sleep state returns to an active output state.

If having both PSUs active is more efficient than having one PSU in the sleep state, the active PSU can also activate the sleeping PSU.

The default PSU settings are as follows:

- If the load on the active PSU is more than 50 percent, then the redundant PSU is switched to the active state.
- If the load on the active PSU falls below 20 percent, then the redundant PSU is switched to the sleep state.

You can configure the hot spare feature by using the iDRAC settings. For more information about iDRAC settings, see the *Integrated Dell Remote Access Controller User's Guide* available at [Dell.com/idracmanuals](https://www.dell.com/support/manuals).

Removing the power supply unit blank

Install the power supply unit (PSU) blank only in the second PSU bay.

Prerequisites

 **CAUTION:** Many repairs may only be done by a certified service technician. You should only perform troubleshooting and simple repairs as authorized in your product documentation, or as directed by the online or telephone service and support team. Damage due to servicing that is not authorized by Dell is not covered by your warranty. Read and follow the safety instructions that are shipped with your product.

Follow the safety guidelines listed in the Safety instructions section.

Steps

If you are installing a second power supply unit (PSU), remove the PSU blank in the bay by pulling the blank outward.

 **CAUTION:** To ensure proper system cooling, the PSU blank must be installed in the second PSU bay in a non-redundant configuration. Remove the PSU blank only if you are installing a second PSU.

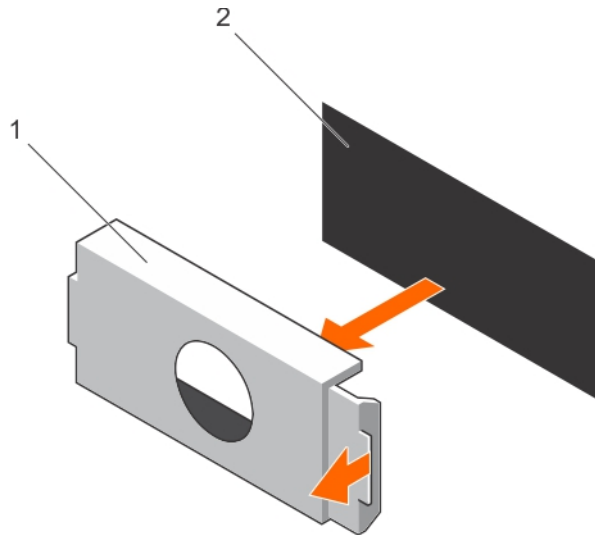

Figure 57. Removing the PSU blank

- a. PSU blank
- b. PSU bay

Next steps

Install the PSU or PSU blank.

Installing the power supply unit blank

Install the power supply unit (PSU) blank only in the second PSU bay.

Prerequisites

CAUTION: Many repairs may only be done by a certified service technician. You should only perform troubleshooting and simple repairs as authorized in your product documentation, or as directed by the online or telephone service and support team. Damage due to servicing that is not authorized by Dell is not covered by your warranty. Read and follow the safety instructions that are shipped with your product.

1. Follow the safety guidelines listed in the Safety instructions section.

Steps

Align the power supply unit blank with the power supply unit slot and push it into the power supply unit slot until it clicks into place.

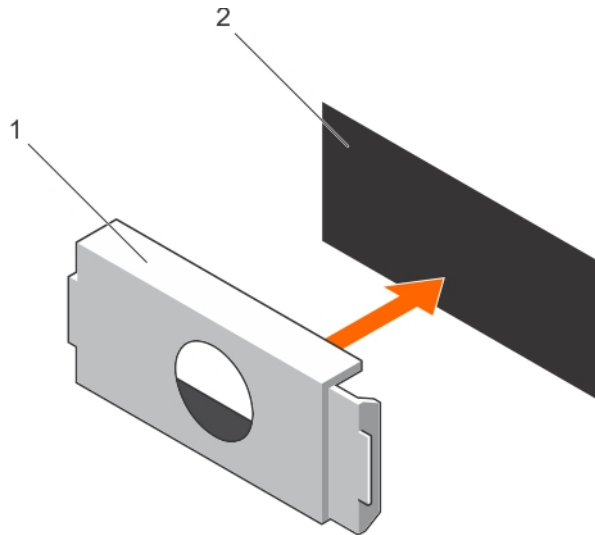

Figure 58. Installing the PSU blank

- a. PSU blank
- b. PSU bay

Removing an AC power supply unit

Prerequisites

- CAUTION:** Many repairs may only be done by a certified service technician. You should only perform troubleshooting and simple repairs as authorized in your product documentation, or as directed by the online or telephone service and support team. Damage due to servicing that is not authorized by Dell is not covered by your warranty. Read and follow the safety instructions that are shipped with your product.
- CAUTION:** The system needs one power supply unit (PSU) for normal operation. On power-redundant systems, remove and replace only one PSU at a time in a system that is powered on.
- NOTE:** You may have to unlatch and lift the optional cable management arm if it interferes with the power supply unit (PSU) removal. For information about the cable management arm, see the system's rack documentation.

Steps

1. Disconnect the power cable from the power source and from the PSU you intend to remove, and then remove the cables from the strap.
2. Press the release latch and slide the PSU out of the chassis by using the PSU handle.

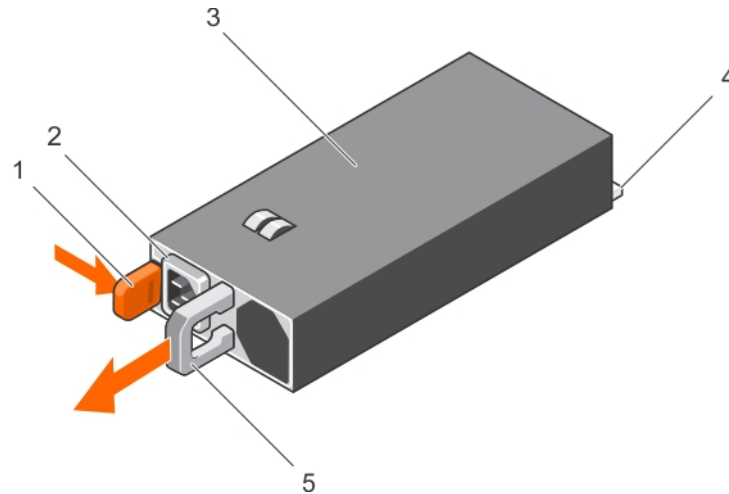

Figure 59. Removing an AC PSU

- | | |
|------------------|------------------------|
| 1. release latch | 2. PSU cable connector |
| 3. PSU | 4. power connector |
| 5. PSU handle | |

Installing an AC power supply unit

Prerequisites

CAUTION: Many repairs may only be done by a certified service technician. You should only perform troubleshooting and simple repairs as authorized in your product documentation, or as directed by the online or telephone service and support team. Damage due to servicing that is not authorized by Dell is not covered by your warranty. Read and follow the safety instructions that are shipped with your product.

NOTE: The maximum output power (shown in watts) is listed on the PSU label.

1. Follow the safety guidelines listed in the Safety instructions section.
2. For systems that support redundant power supply units (PSUs), ensure that both the PSUs are of the same type and have the same maximum output power
3. If installed, remove the PSU blank.

Steps

1. Slide the new PSU into the chassis until the PSU is fully seated and the release latch snaps into place.

NOTE: If you unlatched the cable management arm, relatch it. For information about the cable management arm, see the rack documentation of your system.

2. Connect the power cable to the PSU and plug the cable into a power outlet.

CAUTION: When connecting the power cable, secure the cable with the strap.

NOTE: When installing, hot swapping, or hot-adding a new PSU, wait for 15 seconds for the system to recognize the PSU and determine its status. The PSU redundancy may not occur until discovery is complete. Wait until the new PSU is discovered and enabled before you remove the other PSU. The PSU status indicator turns green to signify that the PSU is functioning properly.

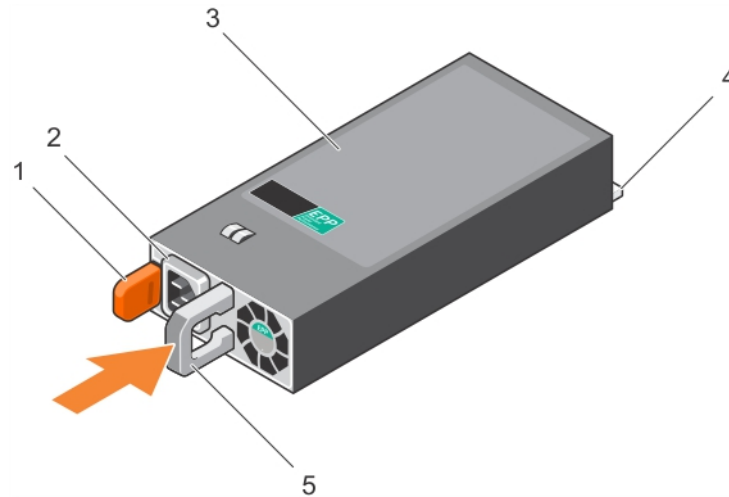

Figure 60. Installing an AC PSU

- | | |
|------------------|------------------------|
| 1. release latch | 2. PSU cable connector |
| 3. PSU | 4. power connector |
| 5. PSU handle | |

System board

A system board (also known as the motherboard) is the main printed circuit board found in systems. The system board allows communication between many of the crucial electronic components of the system, such as the central processing unit (CPU) and memory, and also provides connectors for other peripherals. Unlike a backplane, a system board contains significant number of sub-systems such as the processor expansion cards, and other components.

Removing the system board

Prerequisites

CAUTION: Many repairs may only be done by a certified service technician. You should only perform troubleshooting and simple repairs as authorized in your product documentation, or as directed by the online or telephone service and support team. Damage due to servicing that is not authorized by Dell is not covered by your warranty. Read and follow the safety instructions that are shipped with your product.

CAUTION: If you are using the Trusted Platform Module (TPM) with an encryption key, you may be prompted to create a recovery key during program or System Setup. Be sure to create and safely store this recovery key. If you replace this system board, you must supply the recovery key when you restart your system or program before you can access the encrypted data on your hard drives.

CAUTION: Do not attempt to remove the TPM plug-in module from the system board. Once the TPM plug-in module is installed, it is cryptographically bound to that specific system board. Any attempt to remove an installed TPM plug-in module breaks the cryptographic binding, and it cannot be re-installed or installed on another system board.

1. Follow the safety guidelines listed in the Safety instructions section.
2. Follow the procedure listed in the Before working inside your system section.
3. Remove the following:
 - a. Cooling shroud
 - b. Cooling fan assembly
 - c. Power supply unit(s)
 - d. All expansion card risers
 - e. Integrated storage controller card
 - f. Internal dual SD module
 - g. Internal USB key (if installed)
 - h. PCIe card holder

- i. Cable retention bracket
- j. Heat sink(s)/heat sink blank(s)
- k. Processors(s)/processor blank(s)

CAUTION: To prevent damage to the processor pins when replacing a faulty system board, ensure that you cover the processor socket with the processor protective cap.

- l. Memory modules and memory module blanks
- m. Network daughter card

Steps

1. Disconnect all cables from the system board.

CAUTION: Take care not to damage the system identification button while removing the system board from the chassis.

CAUTION: Do not lift the system board by holding a memory module, processor, or other components.

2. Hold the system board holder, lift the blue release pin, lift the system board, and then slide it toward the front of the chassis. Sliding the system board toward the front of the chassis disengages the connectors from the back of the chassis slots.
3. Lift the system board out of the chassis.

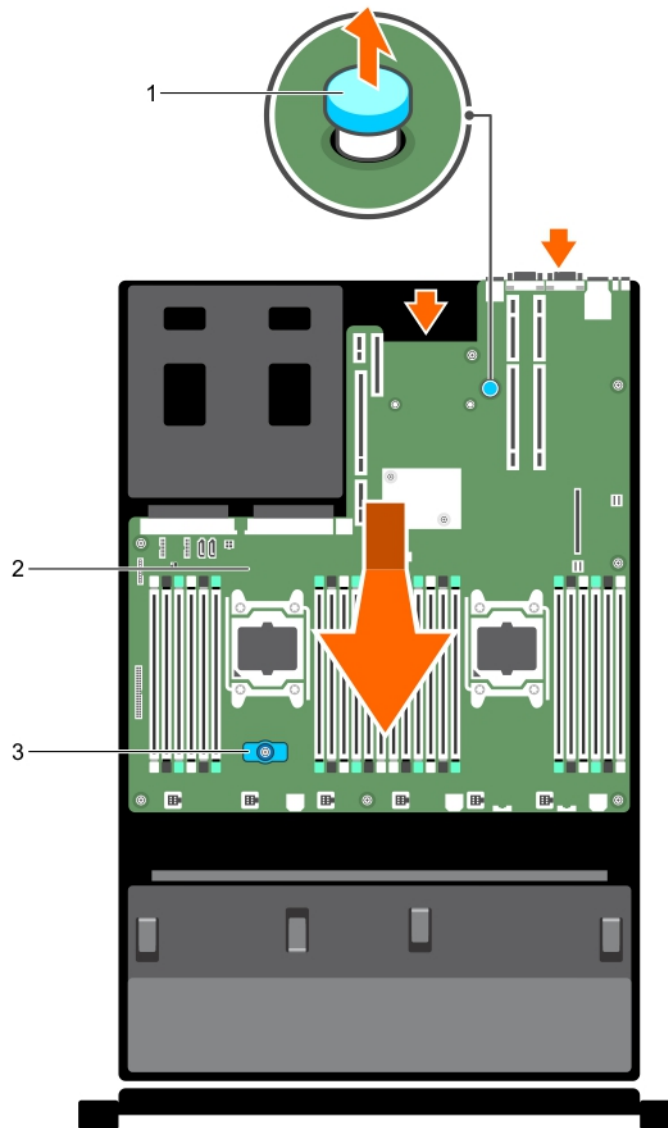

Figure 61. Removing the system board

- a. release pin

- b. system board
- c. system board holder

Next steps

1. Install the system board.
2. Follow the procedure listed in the After working inside your system section.

Related tasks

- [Before working inside your system](#)
- [Removing the cooling shroud](#)
- [Removing the cooling fan assembly](#)
- [Removing an AC power supply unit](#)
- [Removing expansion card risers](#)
- [Removing the integrated storage controller card](#)
- [Removing the optional internal dual SD module](#)
- [Replacing the optional internal USB memory key](#)
- [Removing the PCIe card holder](#)
- [Removing the cable retention bracket](#)
- [Removing a heat sink](#)
- [Removing a processor](#)
- [Removing memory modules](#)
- [Removing the network daughter card](#)
- [Installing the system board](#)
- [After working inside your system](#)

Related reference

- [Safety instructions](#)

Installing the system board

Prerequisites

1. Follow the safety guidelines listed in the Safety instructions section.
2. Follow the procedure listed in the Before working inside your system section.

 **CAUTION:** Many repairs may only be done by a certified service technician. You should only perform troubleshooting and simple repairs as authorized in your product documentation, or as directed by the online or telephone service and support team. Damage due to servicing that is not authorized by Dell is not covered by your warranty. Read and follow the safety instructions that are shipped with your product.

Steps

1. Unpack the new system board assembly.

 **CAUTION:** Do not lift the system board by holding a memory module, processor, or other components.

 **CAUTION:** Take care not to damage the system identification button while placing the system board into the chassis.

2. Hold the touch points and lower the system board into the chassis.
3. Push the system board toward the back of the chassis until the board clicks into place.

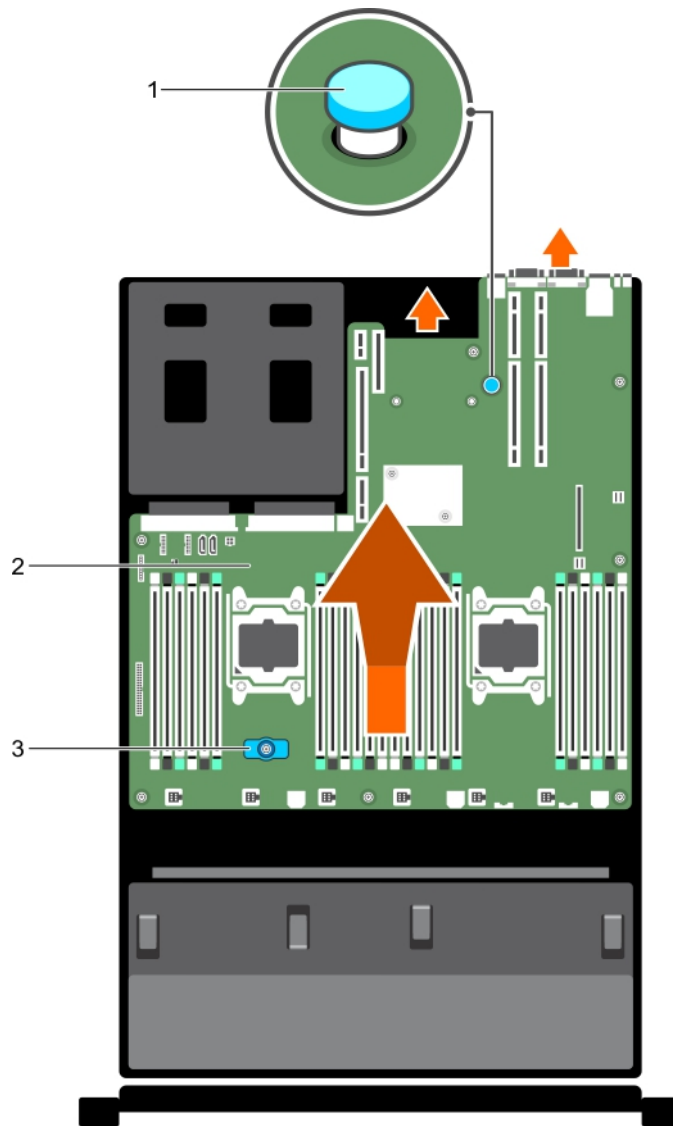

Figure 62. Installing the system board

- a. release pin
- b. system board
- c. system board holder

Next steps

1. Install the Trusted Platform Module (TPM). For information about how to install the TPM, see the Installing the Trusted Platform Module section. For more information on the TPM, see the Trusted Platform Module section.
 - i** **NOTE: The TPM plug-in module is attached to the system board and cannot be removed. A replacement TPM plug-in module will be provided for all system board replacements where a TPM plug-in module was installed.**
2. Replace the following:
 - a. Cable retention bracket
 - b. PCIe card holder
 - c. Integrated storage controller card
 - d. Internal USB key (if applicable)
 - e. Internal dual SD module
 - f. All expansion card risers
 - g. Heat sink(s)/heat sink blank(s) and processors(s)/processor blank(s)
 - h. Memory modules and memory module blanks
 - i. Network daughter card
 - j. Cooling fan assembly

- k. Cooling shroud
 - l. Power supply unit(s)
3. Reconnect all cables to the system board.
 - NOTE:** Ensure that the cables inside the system are routed along the chassis wall and secured using the cable securing bracket.
 4. Follow the procedure listed in the After working inside your system section.
 5. Import your new or existing iDRAC Enterprise license. For more information, see Integrated Dell Remote Access Controller User's Guide, at Dell.com/esmanuals.
 6. Ensure that you:
 - a. Use the Easy Restore feature to restore the Service Tag. For more information, see the Easy restore section.
 - b. If the Service Tag is not backed up in the backup flash device, enter the system Service Tag manually. For more information, see the Entering the system Service Tag section.
 - c. Update the BIOS and iDRAC versions.
 - d. Re-enable the Trusted Platform Module (TPM). For more information, see the Re-enabling the Trusted Platform Module (TPM) section.

Related tasks

- [Installing the cable retention bracket](#)
- [Installing the PCIe card holder](#)
- [Installing the integrated storage controller card](#)
- [Replacing the optional internal USB memory key](#)
- [Installing the optional internal dual SD module](#)
- [Installing expansion card risers](#)
- [Installing a heat sink](#)
- [Installing a processor](#)
- [Installing memory modules](#)
- [Installing the network daughter card](#)
- [Installing the cooling fan assembly](#)
- [Installing the cooling shroud](#)
- [Installing an AC power supply unit](#)

Entering the system Service Tag by using System Setup

If Easy Restore fails to restore the Service Tag, use System Setup to enter the Service Tag.

Steps

1. Turn on the system.
2. Press F2 to enter System Setup.
3. Click **Service Tag Settings**.
4. Enter the Service Tag.
 - NOTE:** You can enter the Service Tag only when the Service Tag field is empty. Ensure that you enter the correct Service Tag. After the Service Tag is entered, it cannot be updated or changed.
5. Click **Ok**.
6. Import your new or existing iDRAC Enterprise license.

For more information, see the *Integrated Dell Remote Access Controller User's Guide* at Dell.com/idracmanuals.

Restoring the Service Tag by using the Easy Restore feature

The Easy Restore feature enables you to restore your system's Service Tag, license, UEFI configuration, and the system configuration data after replacing the system board. All data is automatically backed up in a backup flash device. If BIOS detects a new system board and the Service Tag in the backup flash device, BIOS prompts the user to restore the backup information.

Steps

1. Turn on the system.

If BIOS detects a new system board, and if the Service Tag is present in the backup flash device, BIOS displays the Service Tag, the status of the license, and the **UEFI Diagnostics** version.

2. Perform one of the following steps:
After the restore process is complete, BIOS prompts to restore the system configuration data.
3. Perform one of the following steps:
 - Press **Y** to restore the system configuration data.
 - Press **N** to use the default configuration settings.

After the restore process is complete, the system restarts.

Trusted Platform Module

Trusted Platform Module (TPM) is a dedicated microprocessor designed to secure hardware by integrating cryptographic keys into devices. A software can use a Trusted Platform Module to authenticate hardware devices. As each TPM chip has a unique and secret RSA key burned in as it is produced, it can perform the platform authentication.

CAUTION: Do not attempt to remove the Trusted Platform Module (TPM) from the system board. After the TPM is installed, it is cryptographically bound to that specific system board. Any attempt to remove an installed TPM breaks the cryptographic binding, and it cannot be re-installed or installed on another system board.

NOTE: This is a Field Replaceable Unit (FRU). Removal and installation procedures must be performed only by Dell certified service technicians.

Installing the Trusted Platform Module

Prerequisites

CAUTION: Many repairs may only be done by a certified service technician. You should only perform troubleshooting and simple repairs as authorized in your product documentation, or as directed by the online or telephone service and support team. Damage due to servicing that is not authorized by Dell is not covered by your warranty. Read and follow the safety instructions that are shipped with your product.

CAUTION: Do not attempt to remove the Trusted Platform Module (TPM) from the system board. Once the TPM is installed, it is cryptographically bound to that specific system board. Any attempt to remove an installed TPM breaks the cryptographic binding, and it cannot be re-installed or installed on another system board.

1. Follow the safety guidelines listed in the Safety instructions section.
2. Follow the procedure listed in the Before working inside your system section.

Steps

1. Locate the TPM connector on the system board.

NOTE: To locate the TPM connector on the system board, see the System board connectors section.

2. Align the edge connectors on the TPM with the slot on the TPM connector.
3. Insert the TPM into the TPM connector such that the plastic rivet aligns with the slot on the system board.
4. Press the plastic rivet until the rivet snaps into place.

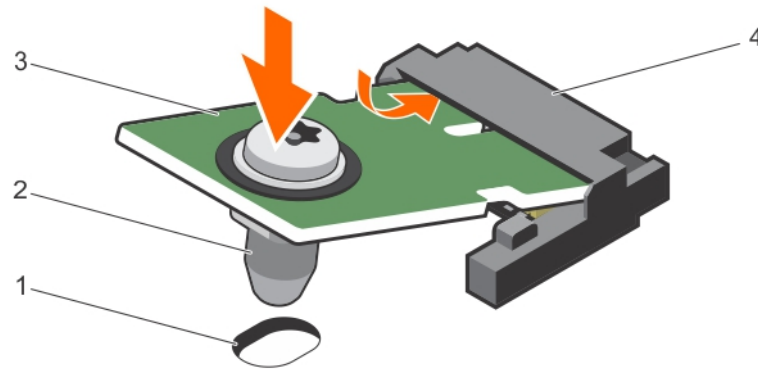

Figure 63. Installing the TPM

- | | |
|-----------------------------------|------------------|
| 1. rivet slot on the system board | 2. plastic rivet |
| 3. TPM | 4. TPM connector |

Next steps

1. Install the system board.
2. Follow the procedure listed in the After working inside your system section.

Related tasks

- [Before working inside your system](#)
- [Installing the system board](#)
- [After working inside your system](#)

Related reference

- [Safety instructions](#)
- [System board jumpers and connectors](#)

Initializing the TPM for BitLocker users

Steps

Initialize the TPM.

For more information about initializing the TPM, see <http://technet.microsoft.com/en-us/library/cc753140.aspx>.

The **TPM Status** changes to **Enabled, Activated**.

Initializing the TPM for TXT users

Steps

1. While booting your system, press F2 to enter System Setup.
2. On the **System Setup Main Menu** screen, click **System BIOS** → **System Security Settings**.
3. From the **TPM Security** option, select **On with Pre-boot Measurements**.
4. From the **TPM Command** option, select **Activate**.
5. Save the settings.
6. Restart your system.
7. Enter **System Setup** again.
8. On the **System Setup Main Menu** screen, click **System BIOS** → **System Security Settings**.
9. From the **Intel TXT** option, select **On**.

Hard drives

Your system supports entry hard drives and enterprise-class hard drives. Entry hard drives are designed for 5x8 operating environment with less workload rating to drives and enterprise-class drives are designed for 24x7 operating environment. Selecting the correct drive class will enable the critical areas of quality, functionality, performance, and reliability to be optimized for the target implementation.

NOTE: Do not mix enterprise-class hard drives with entry hard drives.

Choosing the right drive type depends on the usage pattern. Improper use of entry hard drives (workload rating exceeds 55TB/year) will lead to significant risk and increase the drives failure rate.

For more information on these hard drives, see the *512e and 4Kn Disk Formats* whitepaper and *4K Sector HDD FAQ* document at Dell.com/poweredgemanuals.

All hard drives are connected to the system board through the hard drive backplane. Hard drives are supplied in hot-swappable hard drive carriers that fit in the hard drive slots.

CAUTION: Before attempting to remove or install a hard drive while the system is running, see the documentation for the storage controller card to ensure that the host adapter is configured correctly to support hot-swap hard drive removal and insertion.

CAUTION: Do not turn off or restart your system while the hard drive is being formatted. Doing so can cause a hard drive failure.

Use only hard drives that have been tested and approved for use with the hard drive backplane.

When you format a hard drive, allow enough time for the formatting to be complete. Be aware that high-capacity hard drives can take a long time to format.

Removing a 2.5 inch hard drive blank (rear)

Prerequisites

CAUTION: Many repairs may only be done by a certified service technician. You should only perform troubleshooting and simple repairs as authorized in your product documentation, or as directed by the online or telephone service and support team. Damage due to servicing that is not authorized by Dell is not covered by your warranty. Read and follow the safety instructions that came with the product.

CAUTION: To maintain proper system cooling, all empty hard drive slots must have hard drive blanks installed.

Follow the safety guidelines listed in safety instructions section.

Steps

Pull the hard drive blank out until it is free of the hard drive slot.

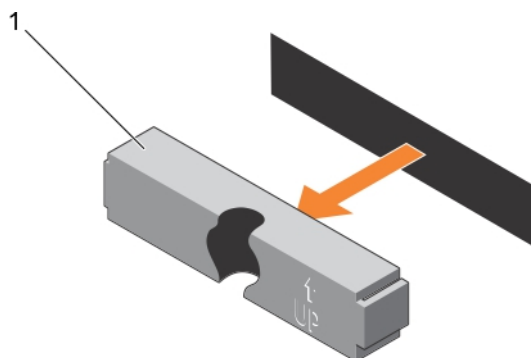

Figure 64. Removing and installing a 2.5 inch hard drive blank (rear)

a. hard drive blank (rear)

Related reference

[Safety instructions](#)

Installing a 2.5 inch hard drive blank (rear)

Prerequisites

1. Follow the safety guidelines listed in the Safety instructions section.

Steps

Insert the hard drive blank into the hard drive slot until it clicks into place.

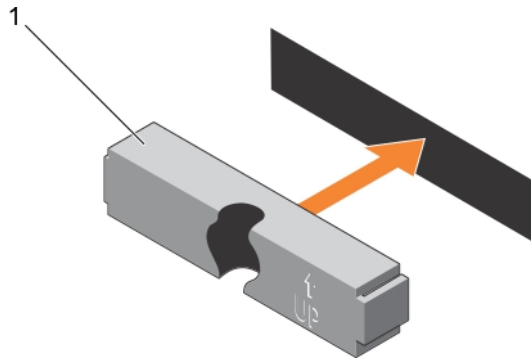

Figure 65. Installing a 2.5 inch hard drive blank (rear)

Next steps

Follow the procedure listed in the After working inside your system section.

Related reference

[Safety instructions](#)

Removing a 3.5-inch hard drive blank

Prerequisites

CAUTION: Many repairs may only be done by a certified service technician. You should only perform troubleshooting and simple repairs as authorized in your product documentation, or as directed by the online or telephone service and support team. Damage due to servicing that is not authorized by Dell is not covered by your warranty. Read and follow the safety instructions that came with the product.

CAUTION: To maintain proper system cooling, all empty hard drive slots must have hard drive blanks installed.

1. Follow the safety guidelines listed in the Safety instructions section.
2. If installed, remove the front bezel.

Steps

Press the release button and slide the blank out of the hard drive slot.

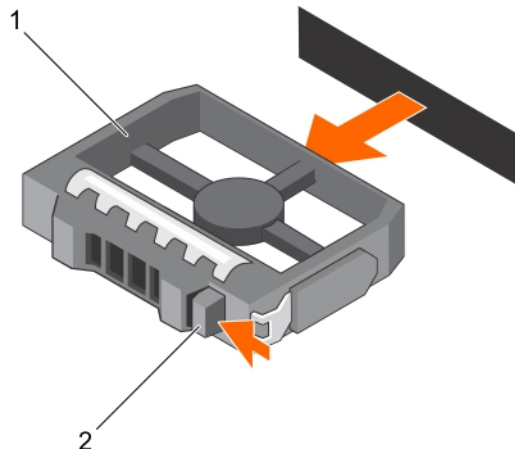

Figure 66. Removing a 3.5-inch hard drive blank

- a. hard drive blank
- b. release button

Next steps

If applicable, install the front bezel.

Related tasks

- [Removing the optional front bezel](#)
- [Installing the optional front bezel](#)

Related reference

- [Safety instructions](#)

Installing a 3.5-inch hard drive blank

Prerequisites

- 1. Follow the safety guidelines listed in the Safety instructions section.
- 2. If installed, remove the front bezel.

Steps

Insert the hard drive blank into the hard drive slot until the release button clicks into place.

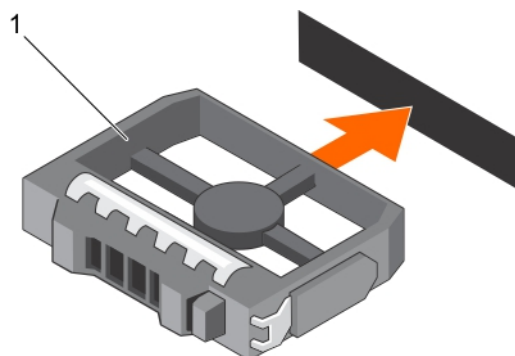

Figure 67. Installing a 3.5-inch hard drive blank

- a. hard drive blank

Next steps

If applicable, install the front bezel.

Related tasks

[Removing the optional front bezel](#)
[Installing the optional front bezel](#)

Related reference

[Safety instructions](#)

Removing a hot swappable hard drive or SSD

Prerequisites

CAUTION: Many repairs may only be done by a certified service technician. You should only perform troubleshooting and simple repairs as authorized in your product documentation, or as directed by the online or telephone service and support team. Damage due to servicing that is not authorized by Dell is not covered by your warranty. Read and follow the safety instructions that came with the product.

1. Follow the safety guidelines listed in the Safety instructions section.
2. Follow the procedure listed in the Before working inside your system section.
3. If applicable, remove the bezel.
4. Using the management software, prepare the hard drive for removal. If the hard drive is online, the green activity or fault indicator flashes while the drive is turning off. When the hard drive indicators are off, the hard drive is ready for removal.

For more information, see the documentation for the storage controller.

CAUTION: To prevent data loss, ensure that your operating system supports hot-swap drive installation. See the documentation supplied with your operating system.

Steps

1. Press the release button to open the hard drive or SSD carrier release handle.
2. Slide the hard drive carrier or SSD out of the hard drive slot.

CAUTION: To maintain proper system cooling, all empty hard drive or SSD slots must have hard drive or SSD blanks installed.

3. If you are not replacing the hard drive or SSD immediately, insert a hard drive or SSD blank in the empty hard drive slot.

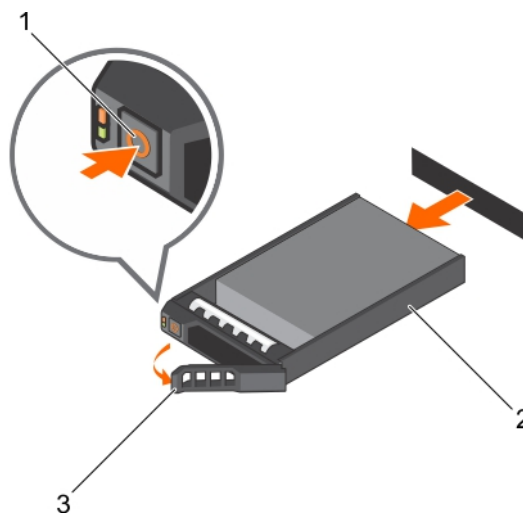

Figure 68. Removing a hot swappable hard drive or SSD

- a. release button
- b. hard drive or SSD carrier
- c. hard drive or SSD carrier handle

Related tasks







[Before working inside your system](#)
[Removing the optional front bezel](#)
[Installing the optional front bezel](#)

Related reference

[Safety instructions](#)

Installing a hot-swap hard drive

Prerequisites

-  **CAUTION:** Many repairs may only be done by a certified service technician. You should only perform troubleshooting and simple repairs as authorized in your product documentation, or as directed by the online or telephone service and support team. Damage due to servicing that is not authorized by Dell is not covered by your warranty. Read and follow the safety instructions that are shipped with your product.
-  **CAUTION:** Use only hard drives that have been tested and approved for use with the hard drive backplane.
-  **CAUTION:** When installing a hard drive, ensure that the adjacent drives are fully installed. Inserting a hard drive carrier and attempting to lock its handle next to a partially installed carrier can damage the partially installed carrier's shield spring and make it unusable.
-  **CAUTION:** Combining SAS and SATA hard drives in the same RAID volume is not supported.
-  **CAUTION:** To prevent data loss, ensure that your operating system supports hot-swap drive installation. See the documentation supplied with your operating system.
-  **CAUTION:** When a replacement hot swappable hard drive is installed and the system is powered on, the hard drive automatically begins to rebuild. Make absolutely sure that the replacement hard drive is blank or contains data that you wish to have over-written. Any data on the replacement hard drive is immediately lost after the hard drive is installed.

Steps

1. If a hard drive blank is installed in the hard drive slot, remove it.
2. Install a hard drive in the hard drive carrier.
3. Press the release button on the front of the hard drive carrier and open the hard drive carrier handle.
4. Insert the hard drive carrier into the hard drive slot until the carrier connects with the backplane.
5. Close the hard drive carrier handle to lock the hard drive in place.

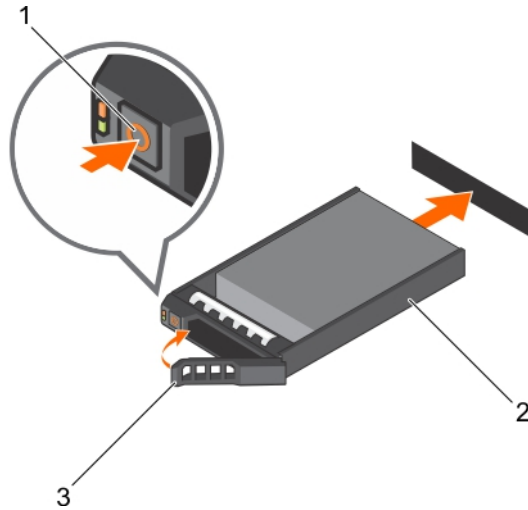

Figure 69. Installing a hot-swappable hard drive or SSD

- a. release button
- b. hard drive or SSD carrier
- c. hard drive or SSD carrier handle

Related tasks

[Removing a 3.5-inch hard drive blank](#)

Removing a hard drive from a hard drive carrier

Prerequisites

1. Keep the Phillips #1 screwdriver ready.
2. Remove the hot swappable hard drive carrier from the system.

Steps

1. Remove the screws from the slide rails on the hard drive carrier.
2. Lift the hard drive out of the hard drive carrier.

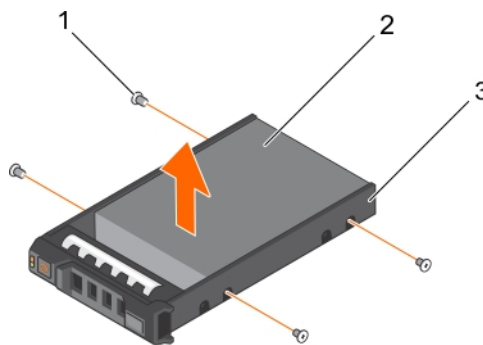

Figure 70. Removing a hard drive into a hard drive carrier

- a. screw (4)
- b. hard drive
- c. hard drive carrier

Installing a hard drive into a hard drive carrier

Prerequisites

CAUTION: Many repairs may only be done by a certified service technician. You should only perform troubleshooting and simple repairs as authorized in your product documentation, or as directed by the online or telephone service and support team. Damage due to servicing that is not authorized by Dell is not covered by your warranty. Read and follow the safety instructions that are shipped with your product.

Steps

1. Insert the hard drive into the hard drive carrier with the connector end of the hard drive toward the back of the carrier.
2. Align the screw holes on the hard drive with the screws holes on the hard drive carrier.
When aligned correctly, the back of the hard drive is flush with the back of the hard drive carrier.
3. Attach the screws to secure the hard drive to the hard drive carrier.

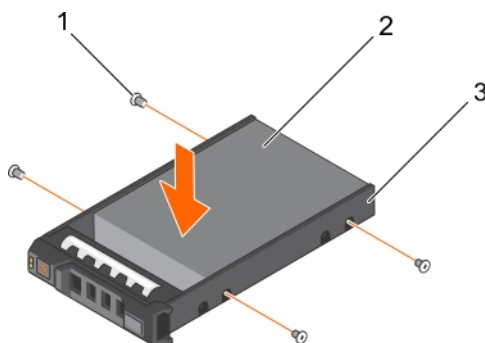

Figure 71. Installing a hard drive into a hard drive carrier

- a. screw (4)
- b. hard drive
- c. hard drive carrier

Next steps

Install the hot swappable hard drive carrier.

Hard drive backplane

Your system supports 3.5 inch (x12) SAS/SATA backplane plus 2.5 inch (x2) SAS/SATA backplane (back).

Removing the hard drive backplane

Prerequisites

CAUTION: Many repairs may only be done by a certified service technician. You should only perform troubleshooting and simple repairs as authorized in your product documentation, or as directed by the online or telephone service and support team. Damage due to servicing that is not authorized by Dell is not covered by your warranty. Read and follow the safety instructions that are shipped with your product.

CAUTION: To prevent damage to the drives and backplane, you must remove the hard drives from the system before removing the backplane.

CAUTION: You must note the number of each hard drive and temporarily label them before removal so that you can replace them in the same locations.

1. Follow the safety guidelines listed in the Safety instructions section.
2. Follow the procedure listed in the Before working inside your system section.
3. Remove the cooling shroud.

4. Remove the cooling fan assembly.
5. Remove all hard drives.

Steps

1. Disconnect the SAS/SATA data, signal, and power cable(s) from the backplane.
2. Press the release tabs and lift the backplane upward and slide it toward the back of the chassis.

NOTE: To prevent damage to the control panel flex cable, unlatch the blocking tab on the connector before removing the flex cable. Do not bend the flex cable at the connector. To unlatch the blocking tab for the x12 backplane, pull the locking tab up. For the x18 and x2 backplanes, rotate the locking tab 90 degrees clockwise.

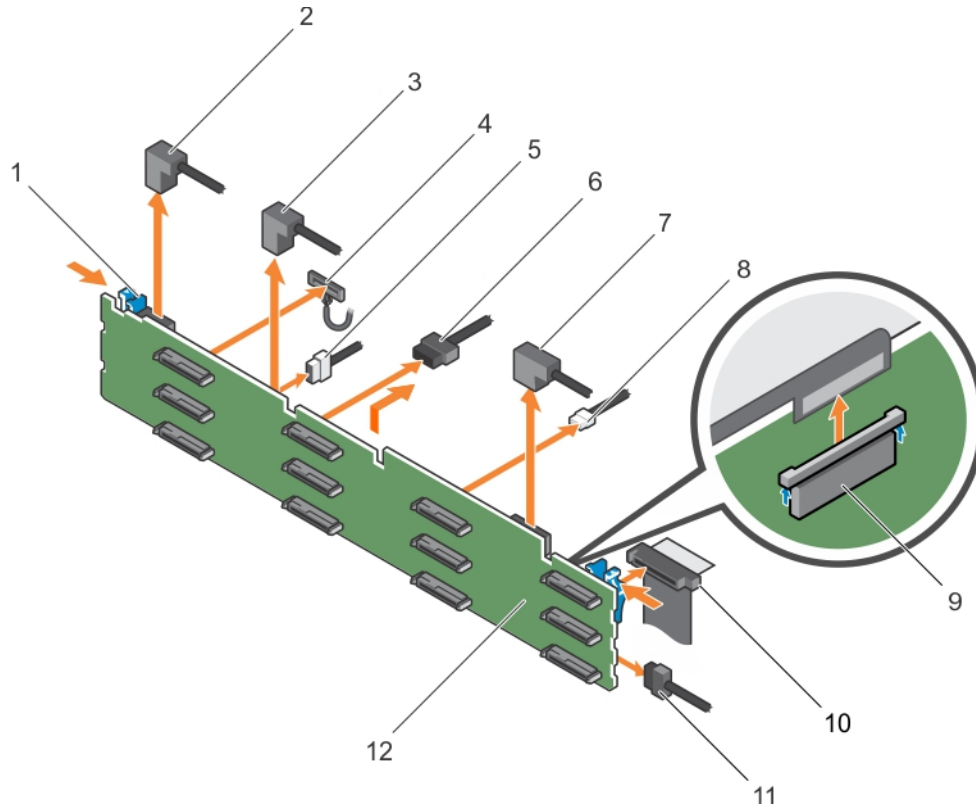

Figure 72. Removing the 3.5 inch (x12) SAS/SATA backplane

- | | |
|---------------------------|---|
| 1. release tab (2) | 2. SAS cable A2 |
| 3. SAS cable A1 | 4. left ear control panel cable |
| 5. backplane signal cable | 6. backplane power cable (2) |
| 7. SAS cable A0/B0 | 8. USB cable |
| 9. control panel cable | 10. right ear control panel flex cable |
| 11. hard drive backplane | 12. hard drive backplane connector (12) |

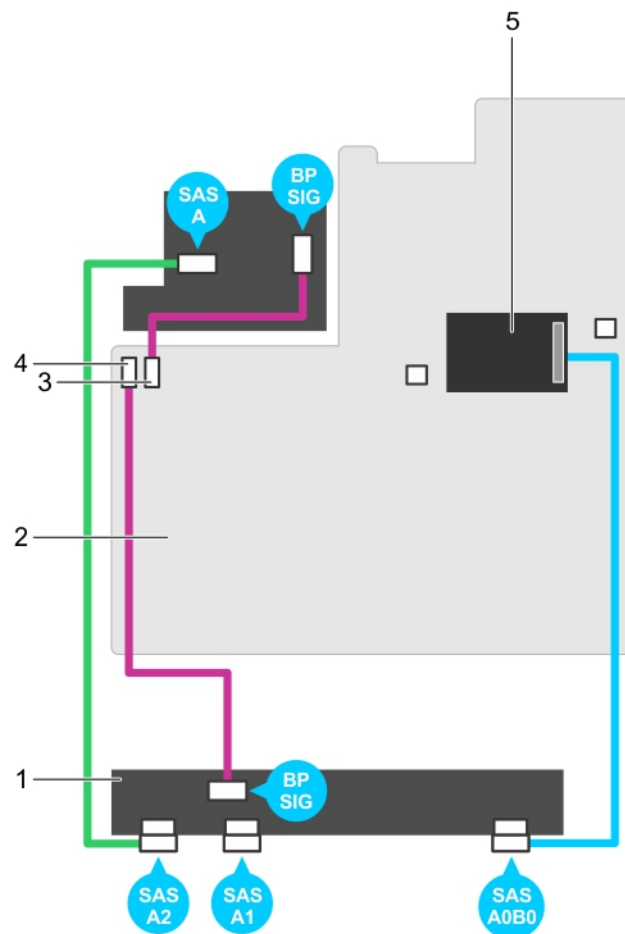

Figure 73. Cabling diagram—3.5 inch (x12) SAS/SATA backplane

- | | |
|---------------------------------------|---------------------------------|
| 1. hard drive backplane | 2. system board |
| 3. backplane signal connector 0 | 4. backplane signal connector 1 |
| 5. integrated storage controller card | |

Next steps

1. Install the hard drive backplane.
2. Follow the procedure listed in the After working inside your system section.

Related tasks

- [Before working inside your system](#)
- [Removing a hot swappable hard drive or SSD](#)
- [Removing the cooling shroud](#)
- [Removing the cooling fan assembly](#)
- [Installing the hard drive backplane](#)
- [Installing the cooling fan assembly](#)
- [Installing the cooling shroud](#)
- [After working inside your system](#)

Related reference

- [Safety instructions](#)

Installing the hard drive backplane

Prerequisites

1. Follow the safety guidelines listed in the Safety instructions section.
2. Follow the procedure listed in the Before working inside your system section.

CAUTION: Many repairs may only be done by a certified service technician. You should only perform troubleshooting and simple repairs as authorized in your product documentation, or as directed by the online or telephone service and support team. Damage due to servicing that is not authorized by Dell is not covered by your warranty. Read and follow the safety instructions that are shipped with your product.

CAUTION: To prevent damage to the control panel flex cable, do not bend the control panel flex cable after it is inserted into the connector.

Steps

1. Use the hooks on the chassis as guides to align the hard drive backplane.
2. Lower the hard drive backplane until the release tabs snap into place.
3. Connect the SAS/SATA/SSD data, signal, and power cable(s) to the backplane.

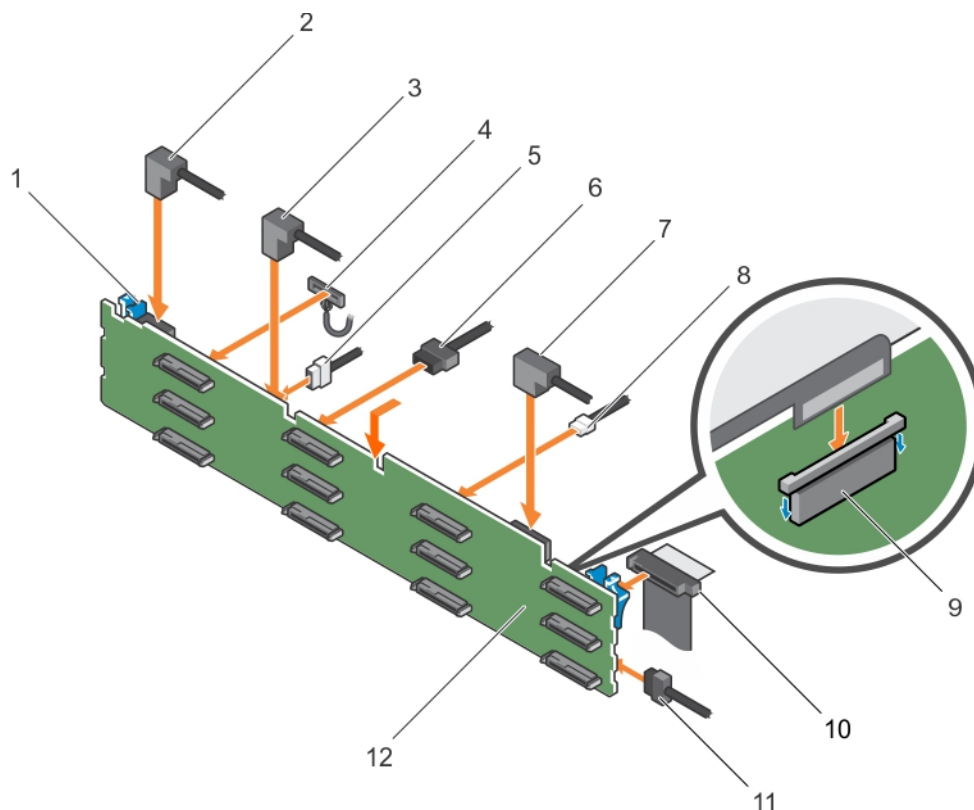

Figure 74. Installing the 3.5 inch (x12) SAS/SATA backplane

- | | |
|---------------------------|---|
| 1. release tab (2) | 2. SAS cable A2 |
| 3. SAS cable A1 | 4. left ear control panel cable |
| 5. backplane signal cable | 6. backplane power cable (2) |
| 7. SAS cable A0/B0 | 8. USB cable |
| 9. control panel cable | 10. right ear control panel flex cable |
| 11. hard drive backplane | 12. hard drive backplane connector (12) |

Next steps

1. Replace the cooling fan assembly.
2. Replace the cooling shroud.

3. Install the hard drives in their original locations.
4. Follow the procedure listed in the After working inside your system section.

Related tasks

[Before working inside your system](#)
[Installing a hot-swap hard drive](#)
[Installing the cooling fan assembly](#)
[Installing the cooling shroud](#)
[After working inside your system](#)

Related reference

[Safety instructions](#)

Removing the optional hard drive backplane (rear)

Prerequisites

1. Follow the safety guidelines listed in the Safety instructions section.
2. Follow the procedure listed in the Before working inside your system section.
3. Remove both hard drives.

 **CAUTION:** Many repairs may only be done by a certified service technician. You should only perform troubleshooting and simple repairs as authorized in your product documentation, or as directed by the online or telephone service and support team. Damage due to servicing that is not authorized by Dell is not covered by your warranty. Read and follow the safety instructions that are shipped with your product.

 **CAUTION:** To prevent damage to the drives and backplane, you must remove the hard drives from the system before removing the backplane.

 **CAUTION:** You must note the number of each hard drive and temporarily label them before removal so that you can replace them in the same locations.

Steps

1. Disconnect all the cables from the backplane.
2. Lift the release pin and slide the backplane toward the front of the chassis.
3. Lift the backplane to remove it from the chassis.

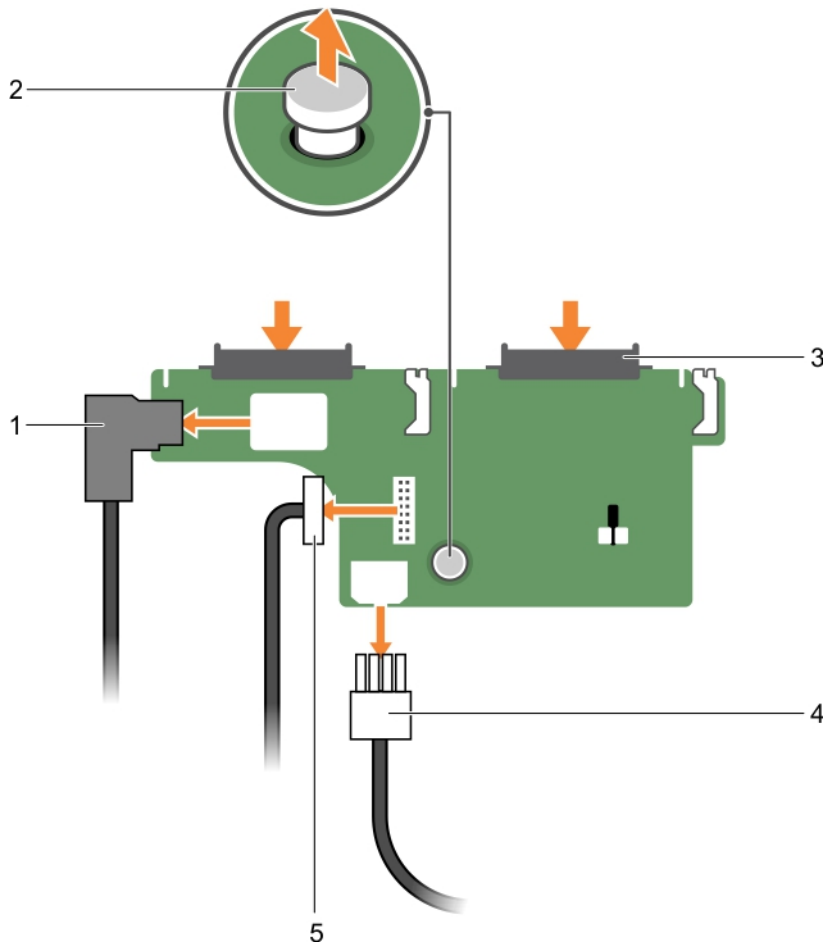

Figure 75. Removing the optional 2.5 inch (x2) hard drive backplane

- | | |
|-----------------------------|----------------|
| 1. SAS cable | 2. release pin |
| 3. hard drive connector (2) | 4. power cable |
| 5. backplane signal cable | |

Related tasks

[Before working inside your system](#)

[Removing a hot swappable hard drive or SSD](#)

[After working inside your system](#)

Related reference

[Safety instructions](#)

Installing the optional hard drive backplane (rear)

Prerequisites

1. Follow the safety guidelines listed in the Safety instructions section.
2. Follow the procedure listed in the Before working inside your system section.

CAUTION: Many repairs may only be done by a certified service technician. You should only perform troubleshooting and simple repairs as authorized in your product documentation, or as directed by the online or telephone service and support team. Damage due to servicing that is not authorized by Dell is not covered by your warranty. Read and follow the safety instructions that are shipped with your product.

Steps

1. Align the notches on the backplane with the notches on the chassis.
2. Lift the release pin and slide the backplane toward the back of the chassis until firmly seated.
3. Release the release pin to lock the backplane to the chassis.
4. Reconnect all the cables to the backplane.

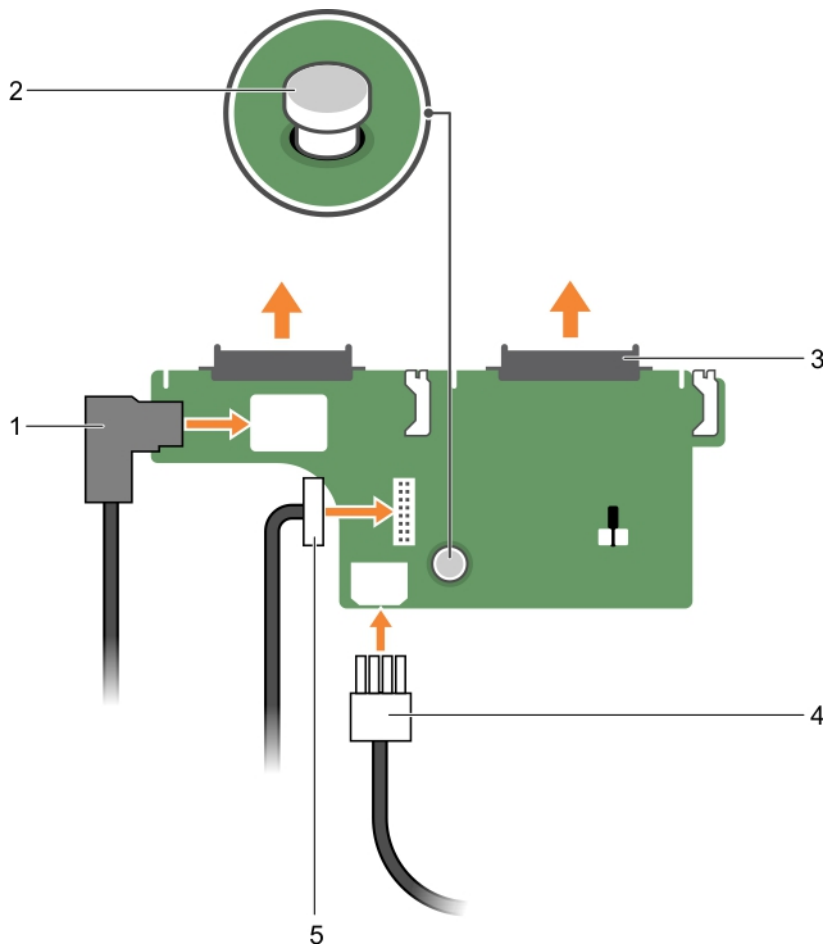

Figure 76. Installing the optional 2.5 inch (x2) hard drive backplane

- | | |
|-----------------------------|----------------|
| 1. SAS cable | 2. release pin |
| 3. hard drive connector (2) | 4. power cable |
| 5. backplane signal cable | |

Next steps

1. Install both the hard drives in their original location.
2. Follow the procedure listed in the After working inside your system section.

Related tasks

[Before working inside your system](#)

[After working inside your system](#)

Related reference

[Safety instructions](#)

SD vFlash card (optional)

An SD vFlash card is a Secure Digital (SD) card that plugs into the SD vFlash card slot in the iDRAC port card. It provides persistent on-demand local storage and a custom deployment environment that enables automation of server configuration, scripts, and imaging. It

emulates USB device(s). For more information, see the Integrated Dell Remote Access Controller User's Guide at Dell.com/idracmanuals.

Replacing an optional SD vFlash media card

Steps

1. Locate the SD vFlash media slot on the system.
2. To remove the SD vFlash media card, push the card inward to release it, and pull the card from the card slot.

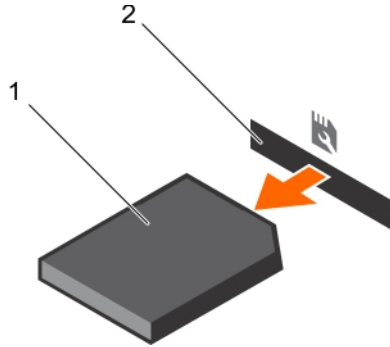

Figure 77. Removing the SD vFlash media card

- a. SD vFlash media card
 - b. SD vFlash media card slot
3. To install an SD vFlash media card, with the label side facing up, insert the contact-pin end of the SD vFlash media card into the card slot on the module.

NOTE: The slot is keyed to ensure correct insertion of the card.

4. Press the card inward to lock it into the slot.

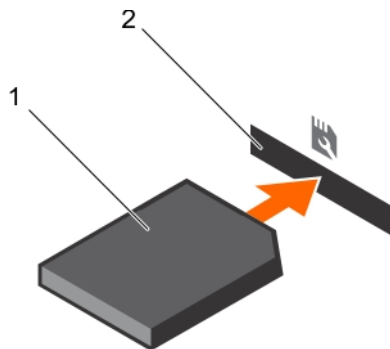

Figure 78. Installing the SD vFlash media card

- a. SD vFlash media card
- b. SD vFlash media card slot

Removing the vFlash media unit

Prerequisites

1. Follow the safety guidelines listed in the Safety instructions section.
2. Follow the procedure listed in the Before working inside your system section.
3. Keep the Phillips #1 screwdriver ready.

CAUTION: Many repairs may only be done by a certified service technician. You should only perform troubleshooting and simple repairs as authorized in your product documentation, or as directed by the online or telephone service and support team. Damage due to servicing that is not authorized by Dell is not covered by your warranty. Read and follow the safety instructions that are shipped with your product.

Steps

1. Remove the screw securing the vFlash media unit to the chassis.
2. Remove the cable from the vFlash media unit and the backplane.
3. Slide the vFlash media unit toward the front of chassis and lift it out of the system.

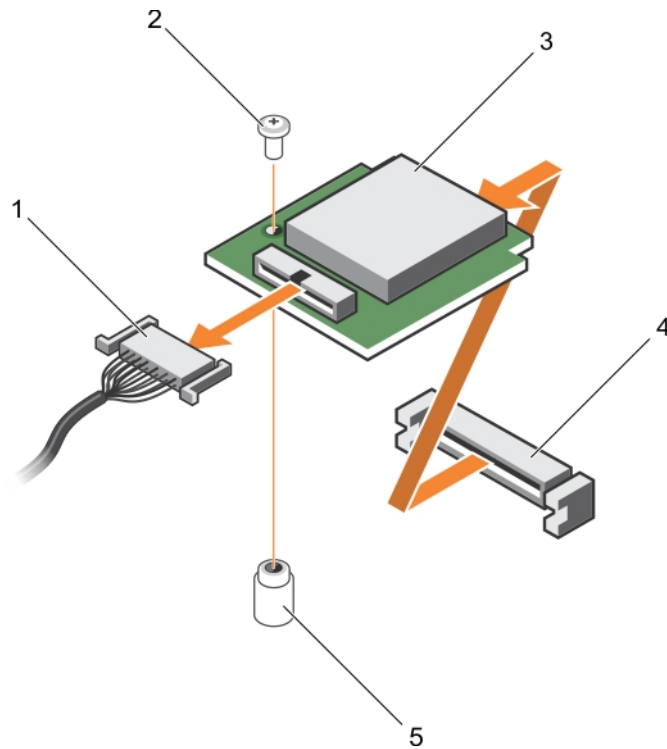

Figure 79. Removing the vFlash media unit

- | | |
|----------------------|----------------------|
| 1. cable | 2. screw |
| 3. vFlash media unit | 4. vFlash media slot |
| 5. standoff | |

Next steps

Follow the procedure listed in the After working inside your system section.

Related tasks

[Before working inside your system](#)

[After working inside your system](#)

Related reference

[Safety instructions](#)

Installing the vFlash media unit

Prerequisites

1. Follow the safety guidelines listed in the Safety instructions section.
2. Follow the procedure listed in the Before working inside your system section.
3. Keep the Phillips #1 screwdriver ready.

CAUTION: Many repairs may only be done by a certified service technician. You should only perform troubleshooting and simple repairs as authorized in your product documentation, or as directed by the online or telephone service and support team. Damage due to servicing that is not authorized by Dell is not covered by your warranty. Read and follow the safety instructions that are shipped with your product.

Steps

1. Slide the vFlash media unit in and align it with the vFlash media slot on the back of the chassis.
2. Connect the cable to the vFlash media unit.
3. Insert and tighten the screw securing the vFlash media unit to the chassis.

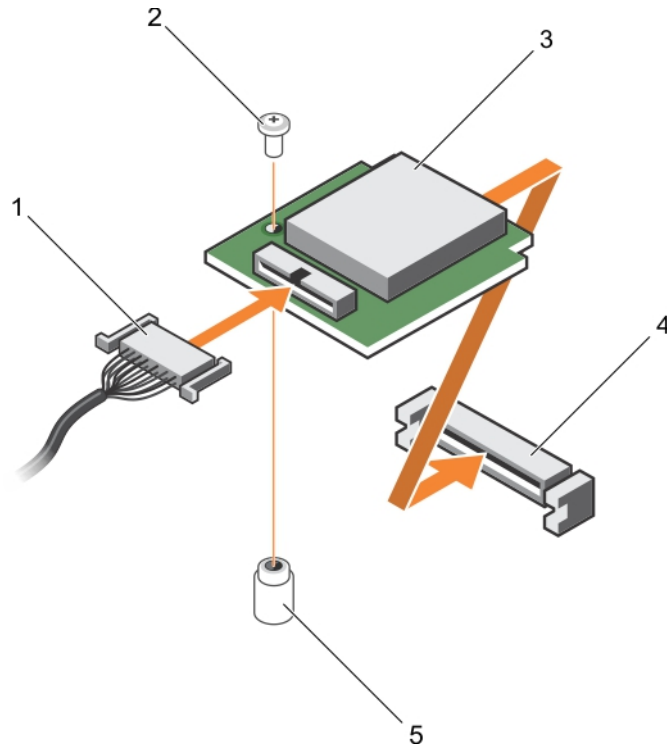

Figure 80. Installing the vFlash media unit

- | | |
|----------------------|----------------------|
| 1. cable | 2. screw |
| 3. vFlash media unit | 4. vFlash media slot |
| 5. standoff | |

Next steps

Follow the procedure listed in the After working inside your system section.

Related tasks

[Before working inside your system](#)

[After working inside your system](#)

Related reference

[Safety instructions](#)

Control panel assembly

Removing the control panel

Prerequisites

1. Follow the safety guidelines listed in the Safety instructions section.
2. Follow the procedure listed in the Before working inside your system section.
3. Keep the T15 Torx screwdriver ready.

CAUTION: Many repairs may only be done by a certified service technician. You should only perform troubleshooting and simple repairs as authorized in your product documentation, or as directed by the online or telephone service and support team. Damage due to servicing that is not authorized by Dell is not covered by your warranty. Read and follow the safety instructions that are shipped with your product.

CAUTION: Do not use excessive force when removing the control panel cable as it can damage the connectors.

Steps

1. Disconnect the control panel cable from the hard drive backplane by pulling on the plastic pull tab.
2. Remove the screws that secure the control panel to the chassis.
3. Fold the plastic pull tab close to the connector.
4. Pull out the control panel cable as you guide the connector and the plastic pull tab through the channel on the chassis.

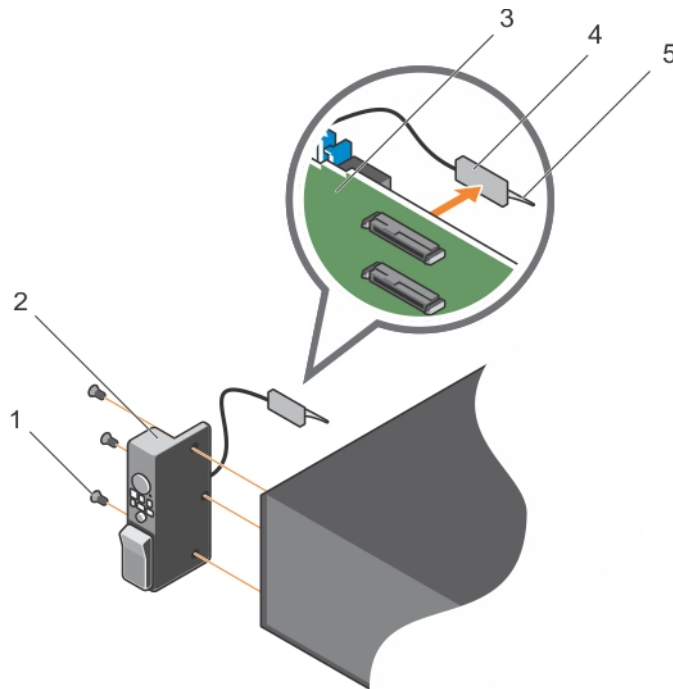

Figure 81. Removing the control panel

- | | |
|-------------------------|------------------|
| 1. screw (3) | 2. control panel |
| 3. hard-drive backplane | 4. connector |
| 5. plastic pull tab | |

Next steps

1. Replace the control panel.
2. Follow the procedure listed in the After working inside your system section.

Related tasks

[Before working inside your system](#)

[Installing the control panel](#)

[After working inside your system](#)

Related reference

[Safety instructions](#)

Installing the control panel

Prerequisites

1. Follow the safety guidelines listed in the Safety instructions section.
2. Follow the procedure listed in the Before working inside your system section.
3. Keep the T15 Torx screwdriver handy.

CAUTION: Many repairs may only be done by a certified service technician. You should only perform troubleshooting and simple repairs as authorized in your product documentation, or as directed by the online or telephone service and support team. Damage due to servicing that is not authorized by Dell is not covered by your warranty. Read and follow the safety instructions that are shipped with your product.

Steps

1. Fold the PPID label around the cable.
 2. Fold the pull tab close to the connector and guide the connector and pull tab into the channel.
 3. Push the cable until the cable passes completely through the channel.
 4. Tighten the screws to secure the control panel to the chassis.
- NOTE:** You must route the cable properly to prevent it from being pinched or crimped.
5. Connect the cable connector to the hard drive backplane by pushing on the center of the connector.

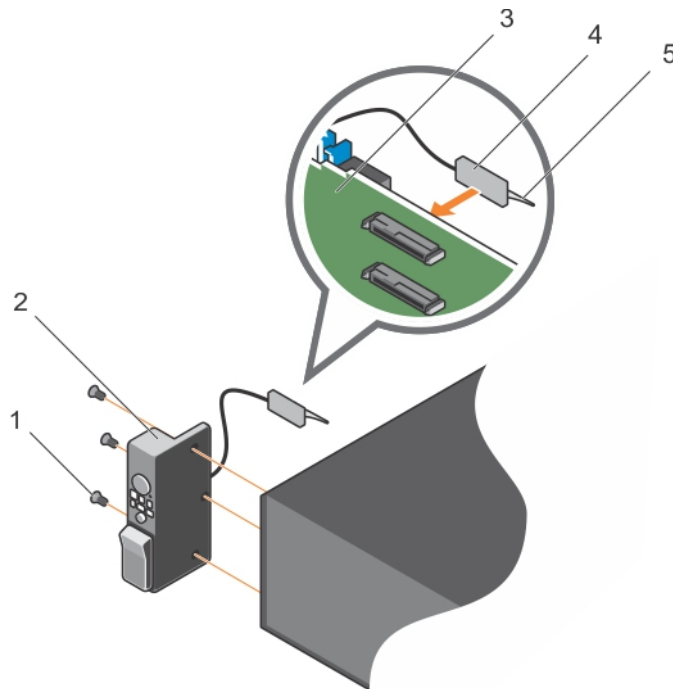

Figure 82. Installing the control panel

- | | |
|-------------------------|------------------|
| 1. screw (3) | 2. control panel |
| 3. hard-drive backplane | 4. connector |
| 5. plastic pull tab | |

Next steps

Follow the procedure listed in the After working inside your system section.

Related tasks

[Before working inside your system](#)

[After working inside your system](#)

Related reference

[Safety instructions](#)

Removing the I/O panel

Prerequisites

1. Follow the safety guidelines listed in the Safety instructions section.
2. Follow the procedure listed in the Before working inside your system section.
3. Keep the T15 Torx screwdriver ready.

CAUTION: Many repairs may only be done by a certified service technician. You should only perform troubleshooting and simple repairs as authorized in your product documentation, or as directed by the online or telephone service and support team. Damage due to servicing that is not authorized by Dell is not covered by your warranty. Read and follow the safety instructions that are shipped with your product.

CAUTION: To prevent damage to the I/O cable, you must release the locking tab before removing or installing the I/O cable from the connector on the hard drive backplane.

Steps

1. Rotate the locking tab on the I/O cable connector clockwise 90 degrees to release the lock.
2. Disconnect the I/O cable from the backplane.
3. Remove the screws securing the I/O panel to the chassis.
4. Pull out the I/O panel cable through the channel on the chassis.

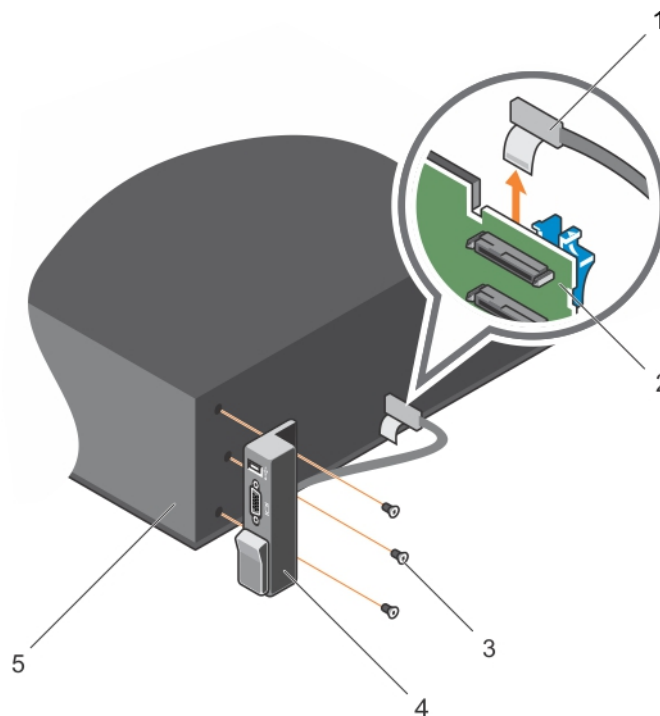

Figure 83. Removing the I/O panel

- | | |
|--------------------|-------------------------|
| 1. I/O panel cable | 2. hard drive backplane |
| 3. screw (3) | 4. I/O panel |
| 5. chassis | |

Next steps

1. Replace the I/O panel.
2. Follow the procedure listed in the After working inside your system section.

Related tasks

[Before working inside your system](#)
[Removing the hard drive backplane](#)
[Installing the I/O panel](#)
[After working inside your system](#)

Related reference

[Safety instructions](#)

Installing the I/O panel

Prerequisites

1. Follow the safety guidelines listed in safety instructions section.
2. Follow the procedure listed in the Before working inside your system section.
3. Keep the T15 Torx screwdriver ready.

CAUTION: Many repairs may only be done by a certified service technician. You should only perform troubleshooting and simple repairs as authorized in your product documentation, or as directed by the online or telephone service and support team. Damage due to servicing that is not authorized by Dell is not covered by your warranty. Read and follow the safety instructions that are shipped with your product.

Steps

1. Fold the PPID label around the cable.
2. Push the cable until the cable passes completely through the channel.

CAUTION: To prevent damage to the I/O cable, you must release the locking tab before removing or installing the I/O cable from the connector on the hard drive backplane.

3. If locked, rotate the locking tab on the I/O cable connector clockwise 90 degrees to release the lock.
4. Connect the I/O panel cable to the connector on the hard drive backplane.
5. Rotate the locking tab on the I/O cable connector counter clockwise 90 degrees to secure the lock.
6. Tighten the screws to secure the control panel to the chassis.

NOTE: You must route the cable properly to prevent it from being pinched or crimped.

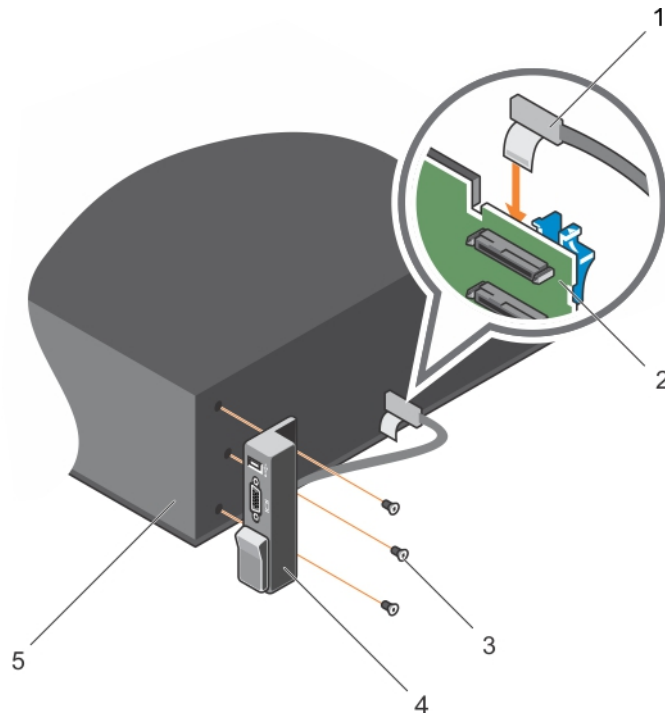

Figure 84. Installing the I/O panel

- | | |
|--------------------|-------------------------|
| 1. I/O panel cable | 2. hard drive backplane |
| 3. screw (3) | 4. I/O panel |
| 5. chassis | |

Next steps

Follow the procedure listed in the After working inside your system section.

Related tasks

- [Before working inside your system](#)
- [After working inside your system](#)

Related reference

- [Safety instructions](#)

Using system diagnostics

If you experience a problem with your system, run the system diagnostics before contacting Dell for technical assistance. The purpose of running system diagnostics is to test your system hardware without requiring additional equipment or risking data loss. If you are unable to fix the problem yourself, service and support personnel can use the diagnostics results to help you solve the problem.

Topics:

- [Dell Embedded System Diagnostics](#)

Dell Embedded System Diagnostics

NOTE: The Dell Embedded System Diagnostics is also known as Enhanced Pre-boot System Assessment (ePSA) diagnostics.

The Embedded System Diagnostics provides a set of options for particular device groups or devices allowing you to:

- Run tests automatically or in an interactive mode
- Repeat tests
- Display or save test results
- Run thorough tests to introduce additional test options to provide extra information about the failed device(s)
- View status messages that inform you if tests are completed successfully
- View error messages that inform you of problems encountered during testing

When to use the Embedded System Diagnostics

Run the Embedded System Diagnostics (ePSA) if your system does not boot.

Running the Embedded System Diagnostics from Boot Manager

Prerequisites

Run the Embedded System Diagnostics (ePSA) if your system does not boot.

Steps

1. When the system is booting, press F11.
2. Use the up arrow and down arrow keys to select **System Utilities > Launch Diagnostics**.
The **ePSA Pre-boot System Assessment** window is displayed, listing all devices detected in the system. The diagnostics starts executing the tests on all the detected devices.

Running the Embedded System Diagnostics from the Dell Lifecycle Controller

Steps

1. As the system boots, press F11.
2. Select **Hardware Diagnostics → Run Hardware Diagnostics**.
The **ePSA Pre-boot System Assessment** window is displayed, listing all devices detected in the system. The diagnostics starts executing the tests on all the detected devices.

System diagnostic controls

Menu	Description
Configuration	Displays the configuration and status information of all detected devices.
Results	Displays the results of all tests that are run.
System health	Provides the current overview of the system performance.
Event log	Displays a time-stamped log of the results of all tests run on the system. This is displayed if at least one event description is recorded.





Jumpers and connectors

Topics:

- [System board jumper settings](#)
- [System board jumpers and connectors](#)
- [Disabling a forgotten password](#)

System board jumper settings

Table 35. System board jumper settings

Jumper	Setting	Description
PWRD_EN	 2 4 6 (default)	The password reset feature is enabled (pins 2–4). BIOS local access is unlocked at the next AC power cycle.
	 2 4 6	The password reset feature is disabled (pins 4–6).
NVRAM_CLR	 1 3 5 (default)	The configuration settings are retained at the next system boot (pins 3–5).
	 1 3 5	The configuration settings are cleared at system boot (pins 1–3).

Related tasks

[Disabling a forgotten password](#)

System board jumpers and connectors

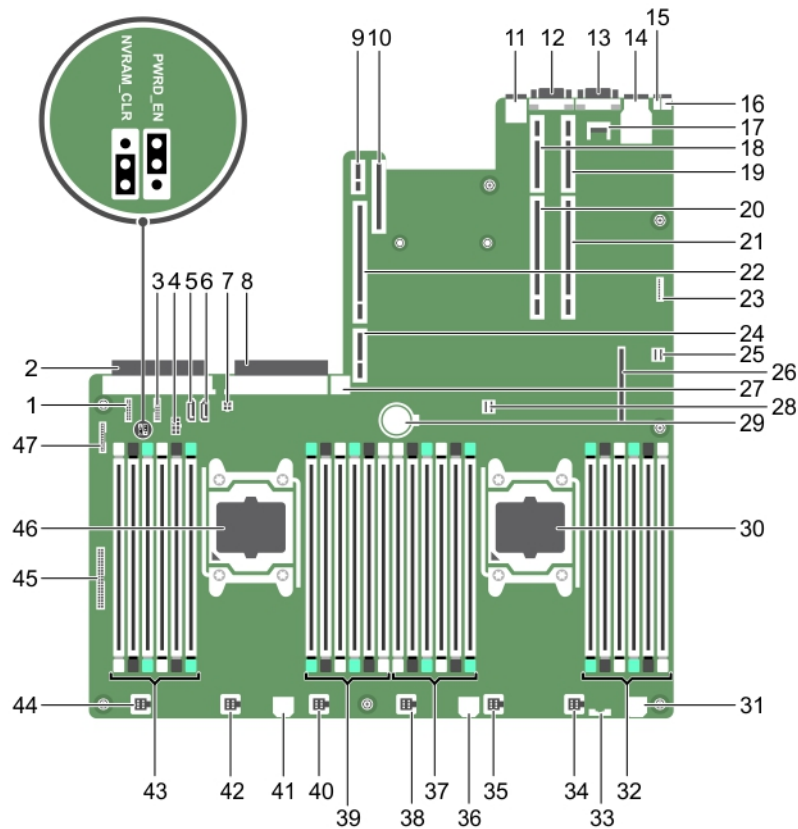

Figure 85. System board jumpers and connectors

Table 36. System board connectors and jumpers

Item	Connector	Description
1	J_BP_SIG1	Backplane signal connector 1
2	J_PS_2	PSU 2 connector
3	J_BP_SIG0	Backplane signal connector 0
4	J_BP0	Backplane power connector 0
5	J_SATA_CD	Optical drive SATA connector
6	J_SATA_TBU	Tape backup unit SATA connector
7	J_TBU	Tape backup unit power connector
8	J_PS_1	PSU 1 connector
9	J_IDSMD	Internal dual SD module connector
10	J_NDC	Network daughter card connector
11	J_USB	USB port
12	J_VIDEO_REAR	Video connector
13	J_COM1	Serial connector
14	J_IDRAC_RJ45	iDRAC8 connector
15	J_CYC	System identification connector
16	CYC_ID	System identification button

Item	Connector	Description
17	J_TPM_MODULE	Trusted Platform Module connector
18	J_RISER_2AX	Riser 3 connector
19	J_RISER_1AX	Riser 1 connector
20	J_RISER_2BX	Riser 2 connector
21	J_RISER_1BX	Riser 1 connector
22	J_RISER_3AX	Riser 3 connector
23	J_QS	Quick Sync bezel connector
24	J_RISER_3BX	Riser 3 connector
25	J_SATA_B	Internal SAS connector
26	J_STORAGE	Mini PERC connector
27	J_USB_INT	Internal USB port
28	J_SATA_A	Internal SAS connector
29	BAT	Battery connector
30	CPU 2	Processor 2 socket
31	J_BP3	Backplane power connector 3
32	B10, B6, B2, B9, B5, B1	Memory module sockets
33	J_BP_SIG2	Backplane signal connector 2
34	J_FAN2U_6	Cooling fan connector
35	J_FAN2U_5	Cooling fan connector
36	J_BP2	Backplane power connector 2
37	B3, B7, B11, B4, B8, B12	Memory module sockets
38	J_FAN2U_4	Cooling fan connector
39	A10, A6, A2, A9, A5, A1	Memory module sockets
40	J_FAN2U_3	Cooling fan connector
41	J_BP1	Backplane power connector
42	J_FAN2U_2	Cooling fan connector
43	A3, A7, A11, A4, A8, A12	Memory module sockets
44	J_FAN2U_1	Cooling fan connector
45	J_CTRL_PNL	Control panel signal connector
46	CPU 1	Processor 1 socket
47	J_FP_USB	Front panel USB port

Disabling a forgotten password

The software security features of the system include a system password and a setup password. The password jumper enables these password features or disables them and clears any password(s) currently in use.

Prerequisites

CAUTION: Many repairs may only be done by a certified service technician. You should only perform troubleshooting and simple repairs as authorized in your product documentation, or as directed by the online or telephone service and support team. Damage due to servicing that is not authorized by Dell is not covered by your warranty. Read and follow the safety instructions that are shipped with your product.

Steps

1. Turn off the system, including any attached peripherals, and disconnect the system from the electrical outlet.
2. Remove the system cover.
3. Move the jumper on the system board jumper from pins 4 and 6 to pins 2 and 4.
4. Install the system cover.

The existing passwords are not disabled (erased) until the system boots with the jumper on pins 2 and 4. However, before you assign a new system and/or setup password, you must move the jumper back to pins 4 and 6.

 **NOTE: If you assign a new system and/or setup password with the jumper on pins 2 and 4, the system disables the new password(s) the next time it boots.**

5. Reconnect the system to its electrical outlet and turn the system on, including any attached peripherals.
6. Turn off the system, including any attached peripherals, and disconnect the system from the electrical outlet.
7. Remove the system cover.
8. Move the jumper on the system board jumper from pins 2 and 4 to pins 4 and 6.
9. Install the system cover.
10. Reconnect the system to its electrical outlet and turn the system on, including any attached peripherals.
11. Assign a new system and/or setup password.

Troubleshooting your system

Safety first — for you and your system

 **CAUTION:** Many repairs may only be done by a certified service technician. You should only perform troubleshooting and simple repairs as authorized in your product documentation, or as directed by the online or telephone service and support team. Damage due to servicing that is not authorized by Dell is not covered by your warranty. Read and follow the safety instructions that are shipped with your product.

Topics:

- [Troubleshooting system startup failure](#)
- [Troubleshooting external connections](#)
- [Troubleshooting the video subsystem](#)
- [Troubleshooting a USB device](#)
- [Troubleshooting iDRAC Direct \(USB XML configuration\)](#)
- [Troubleshooting iDRAC Direct \(Laptop connection\)](#)
- [Troubleshooting a serial I/O device](#)
- [Troubleshooting a NIC](#)
- [Troubleshooting a wet system](#)
- [Troubleshooting a damaged system](#)
- [Troubleshooting the system battery](#)
- [Troubleshooting power supply units](#)
- [Troubleshooting cooling problems](#)
- [Troubleshooting cooling fans](#)
- [Troubleshooting system memory](#)
- [Troubleshooting an internal USB key](#)
- [Troubleshooting an SD card](#)
- [Troubleshooting an optical drive](#)
- [Troubleshooting a tape backup unit](#)
- [Troubleshooting a hard drive](#)
- [Troubleshooting a storage controller](#)
- [Troubleshooting expansion cards](#)
- [Troubleshooting processors](#)
- [System messages](#)

Troubleshooting system startup failure

If you boot the system to the BIOS boot mode after installing an operating system from the UEFI Boot Manager, the system stops responding. To avoid this issue, you must boot to the same boot mode in which you installed the operating system.

For all other startup issues, note the system messages that appear on the screen.

Troubleshooting external connections

Before troubleshooting any external devices, ensure that all external cables are securely attached to the external connectors on your system before troubleshooting any external devices.

Troubleshooting the video subsystem

Prerequisites

 **NOTE:** Ensure the **Local Server Video Enabled** option is selected in the iDRAC Graphical User Interface (GUI), under **Virtual Console**. If this option is not selected, local video is disabled.

Steps

1. Check the cable connections (power and display) to the monitor.
2. Check the video interface cabling from the system to the monitor.
3. Run the appropriate diagnostic test.

Results

If the tests run successfully, the problem is not related to video hardware.

Next steps

If the tests fail, see the Getting help section.

Related reference

[Getting help](#)

Troubleshooting a USB device

Prerequisites

 **NOTE:** Follow steps 1 to 6 to troubleshoot a USB keyboard or mouse. For other USB devices, go to step 7.

Steps

1. Disconnect the keyboard and/or mouse cables from the system and reconnect them.
2. If the problem persists, connect the keyboard and/or mouse to another USB port on the system.
3. If the problem is resolved, restart the system, enter System Setup, and check if the non-functioning USB ports are enabled.
 **NOTE:** Older operating systems may not support USB 3.0.
4. Check if USB 3.0 is enabled in System Setup. If enabled, disable it and see if the issue is resolved.
5. In **iDRAC Settings Utility**, ensure that **USB Management Port Mode** is configured as **Automatic** or **Standard OS Use**.
6. If the problem is not resolved, replace the keyboard and/or mouse with a known working keyboard or mouse.
If the problem is not resolved, proceed to step 7 to troubleshoot other USB devices attached to the system.
7. Turn off all attached USB devices, and disconnect them from the system.
8. Restart the system.
9. If your keyboard is functioning, enter System Setup, verify that all USB ports are enabled on the **Integrated Devices** screen. If your keyboard is not functioning, use remote access to enable or disable the USB options.
10. Check if USB 3.0 is enabled in System Setup. If it is enabled, disable it and restart your system.
11. If the system is not accessible, reset the NVRAM_CLR jumper inside your system and restore the BIOS to the default settings. See the System board jumper setting section.
12. In the **iDRAC Settings Utility**, ensure that **USB Management Port Mode** is configured as **Automatic** or **Standard OS Use**.
13. Reconnect and turn on each USB device one at a time.
14. If a USB device causes the same problem, turn off the device, replace the USB cable with a known good cable, and turn on the device.

Next steps

If all troubleshooting fails, see the Getting help section.

Related reference

[Getting help](#)

[System board jumper settings](#)

Troubleshooting iDRAC Direct (USB XML configuration)

For information about USB storage device and server configuration, see the Integrated Dell Remote Access Controller User's Guide at Dell.com/idracmanuals.

Steps

1. Ensure that your USB storage device is connected to the front USB Management Port, identified by  icon.
2. Ensure that your USB storage device is configured with an NTFS or an FAT32 file system with only one partition.
3. Verify that the USB storage device is configured correctly. For more information about configuring the USB storage device, see the Integrated Dell Remote Access Controller User's Guide at Dell.com/idracmanuals.
4. In the **iDRAC Settings Utility**, ensure that **USB Management Port Mode** is configured as **Automatic** or **iDRAC Direct Only**.
5. Ensure that the **iDRAC Managed: USB XML Configuration** option is either **Enabled** or **Enabled only when the server has default credential settings**.
6. Remove and reinsert the USB storage device.
7. If import operation does not work, try with a different USB storage device.

Next steps

If all troubleshooting fails, see the Getting help section.

Related reference

[Getting help](#)

Troubleshooting iDRAC Direct (Laptop connection)

For information about USB laptop connection and server configuration, see the *Integrated Dell Remote Access Controller User's Guide* at Dell.com/idracmanuals.

Steps

1. Ensure that your laptop is connected to the front USB Management Port, identified by  icon with a USB Type A/A cable.
2. On the **iDRAC Settings Utility** screen, ensure that **USB Management Port Mode** is configured as **Automatic** or **iDRAC Direct Only**.
3. If the laptop is running Windows operating system, ensure that the iDRAC Virtual USB NIC device driver is installed.
4. If the driver is installed, ensure that you are not connected to any network through WiFi or cabled ethernet, as iDRAC Direct uses a non-routable address.

Next steps

If all troubleshooting fails, see the Getting help section.

Related reference

[Getting help](#)

Troubleshooting a serial I/O device

Steps

1. Turn off the system and any peripheral devices connected to the serial port.
2. Swap the serial interface cable with a known working cable, and turn on the system and the serial device.
If the problem is resolved, replace the interface cable with a known working cable.
3. Turn off the system and the serial device, and swap the serial device with a compatible device.
4. Turn on the system and the serial device.

Next steps

If the problem persists, see the Getting help section.

Related reference

[Getting help](#)

Troubleshooting a NIC

Steps

1. Run the appropriate diagnostic test. For more information, see the Using system diagnostics section for the available diagnostic tests.
2. Restart the system and check for any system messages pertaining to the NIC controller.
3. Check the appropriate indicator on the NIC connector:
 - If the link indicator does not glow, the cable connected might be disengaged.
 - If the activity indicator does not glow, the network driver files might be damaged or missing.
Install or replace the drivers as necessary. For more information, see the NIC documentation.
 - Try another known good network cable.
 - If the problem persists, use another connector on the switch or hub.
4. Ensure that the appropriate drivers are installed and the protocols are bound. For more information, see the NIC documentation.
5. Enter System Setup and confirm that the NIC ports are enabled on the **Integrated Devices** screen.
6. Ensure that all the NICs, hubs, and switches on the network are set to the same data transmission speed and duplex. For more information, see the documentation for each network device.
7. Ensure that all network cables are of the proper type and do not exceed the maximum length.

Next steps

If the problem persists, see the Getting help section.

Related reference

[Getting help](#)

[Using system diagnostics](#)

Troubleshooting a wet system

Prerequisites

 **CAUTION:** Many repairs may only be done by a certified service technician. You should only perform troubleshooting and simple repairs as authorized in your product documentation, or as directed by the online or telephone service and support team. Damage due to servicing that is not authorized by Dell is not covered by your warranty. Read and follow the safety instructions that are shipped with your product.

Steps

1. Turn off the system and attached peripherals, and disconnect the system from the electrical outlet.
2. Remove the system cover.
3. Remove the following components (if installed) from the system:
 - Power supply unit(s)
 - Optical drive
 - Hard drives
 - Hard drive backplane
 - USB memory key
 - Hard drive tray
 - Cooling shroud
 - Expansion card risers (if installed)
 - Expansion cards
 - Cooling fan assembly (if installed)
 - Cooling fans
 - Memory modules
 - Processor(s) and heat sink(s)
 - System board
4. Let the system dry thoroughly for at least 24 hours.
5. Reinstall the components you removed in step 3 except the expansion cards.
6. Install the system cover.
7. Turn on the system and attached peripherals.
If the problem persists, see the Getting help section.
8. If the system starts properly, turn off the system, and reinstall all the expansion cards that you removed.
9. Run the appropriate diagnostic test. For more information, see the Using system diagnostics section.

Next steps

If the tests fail, see the Getting help section.

Related reference

[Getting help](#)

[Using system diagnostics](#)

Troubleshooting a damaged system

Prerequisites

 **CAUTION:** Many repairs may only be done by a certified service technician. You should only perform troubleshooting and simple repairs as authorized in your product documentation, or as directed by the online or telephone service and support team. Damage due to servicing that is not authorized by Dell is not covered by your warranty. Read and follow the safety instructions that are shipped with your product.

Steps

1. Turn off the system and attached peripherals, and disconnect the system from the electrical outlet.
2. Remove the system cover.
3. Ensure that the following components are properly installed:
 - cooling shroud
 - expansion card risers (if installed)
 - expansion cards
 - power supply unit(s)
 - cooling fan assembly (if installed)
 - cooling fans

- processor(s) and heat sink(s)
 - memory modules
 - hard drive carriers/cage
 - hard drive backplane
4. Ensure that all cables are properly connected.
 5. Install the system cover.
 6. Run the appropriate diagnostic test. For more information, see the Using system diagnostics section.

Next steps

If the problem persists, see the Getting help section.

Related reference

[Getting help](#)

[Using system diagnostics](#)

Troubleshooting the system battery

Prerequisites

 **CAUTION:** Many repairs may only be done by a certified service technician. You should only perform troubleshooting and simple repairs as authorized in your product documentation, or as directed by the online or telephone service and support team. Damage due to servicing that is not authorized by Dell is not covered by your warranty. Read and follow the safety instructions that are shipped with your product.

 **NOTE:** If the system is turned off for long periods of time (for weeks or months), the NVRAM may lose its system configuration information. This situation is caused by a defective battery.

 **NOTE:** Some software may cause the system time to speed up or slow down. If the system seems to operate normally except for the time set in System Setup, the problem may be caused by a software, rather than by a defective battery.

Steps

1. Re-enter the time and date in System Setup.
2. Turn off the system, and disconnect it from the electrical outlet for at least an hour.
3. Reconnect the system to the electrical outlet, and turn on the system.
4. Enter System Setup.

If the date and time displayed in System Setup are not correct, check the System Error Log (SEL) for system battery messages.

Next steps

If the problem persists, see the Getting help section.

Related reference

[Getting help](#)

Troubleshooting power supply units

Prerequisites

 **CAUTION:** Many repairs may only be done by a certified service technician. You should only perform troubleshooting and simple repairs as authorized in your product documentation, or as directed by the online or telephone service and support team. Damage due to servicing that is not authorized by Dell is not covered by your warranty. Read and follow the safety instructions that are shipped with your product.

Troubleshooting power source problems

Steps

1. Press the power button to ensure that your system is turned on. If the power indicator does not glow when the power button is pressed, press the power button firmly.
2. Plug in another working power supply unit to ensure that the system board is not faulty.
3. Ensure that no loose connections exist.
For example, loose power cables.
4. Ensure that the power source meets applicable standards.
5. Ensure that there are no short circuits.
6. Have a qualified electrician check the line voltage to ensure that it meets the needed specifications.

Troubleshooting power supply unit problems

Steps

1. Ensure that no loose connections exist.
For example, loose power cables.
2. Ensure that the power supply handle/LED indicates that the power supply is working properly.
3. If you have recently upgraded your system, ensure that the power supply unit has enough power to support the new system.
4. If you have a redundant power supply configuration, ensure that both the power supply units are of the same type and wattage.
If the LED You may have to upgrade to a higher wattage power supply unit.
5. Ensure that you use only power supply units with the Extended Power Performance (EPP) label on the back.
6. Reseat the power supply unit.

 **NOTE: After installing a power supply unit, allow several seconds for the system to recognize the power supply unit and determine if it is working properly.**

If the problem persists, see the Getting help section.

Related reference

[Getting help](#)

Troubleshooting cooling problems

 **CAUTION: Many repairs may only be done by a certified service technician. You should only perform troubleshooting and simple repairs as authorized in your product documentation, or as directed by the online or telephone service and support team. Damage due to servicing that is not authorized by Dell is not covered by your warranty. Read and follow the safety instructions that are shipped with your product.**

Ensure that the following conditions exist:

- System cover, cooling shroud, EMI filler panel, memory module blank, or back filler bracket is not removed.
- Ambient temperature is not higher than the system specific ambient temperature.
- External airflow is not obstructed.
- A cooling fan is not removed or has not failed.
- The expansion card installation guidelines have been followed.

Additional cooling can be added by one of the following methods:

From the iDRAC web GUI:

1. Click **Hardware > Fans > Setup**.
2. From the **Fan Speed Offset** drop-down list, select the cooling level required or set the minimum fan speed to a custom value.

From F2 System Setup:

1. Select **iDRAC Settings > Thermal**, and set a higher fan speed from the fan speed offset or minimum fan speed.

From RACADM commands:

1. Run the command `racadm help system.thermalsettings`

For more information, see the Integrated Dell Remote Access User's Guide at Dell.com/idracmanuals.

Troubleshooting cooling fans

Prerequisites

CAUTION: Many repairs may only be done by a certified service technician. You should only perform troubleshooting and simple repairs as authorized in your product documentation, or as directed by the online or telephone service and support team. Damage due to servicing that is not authorized by Dell is not covered by your warranty. Read and follow the safety instructions that are shipped with your product.

NOTE: The fan number is referenced by the systems management software. In the event of a problem with a particular fan, you can easily identify and replace it by noting down the fan numbers on the cooling fan assembly.

1. Follow the safety guidelines listed in the Safety instructions section.
2. Follow the procedure listed in the Before working inside your system section.

Steps

1. Reseat the fan or the fan's power cable.
2. Restart the system.

Next steps

1. Follow the procedure listed in the After working inside your system section.
2. If the problem persists, see the Getting help section.

Related tasks

[Before working inside your system](#)

Related reference

[Getting help](#)

[Safety instructions](#)

Troubleshooting system memory

Prerequisites

CAUTION: Many repairs may only be done by a certified service technician. You should only perform troubleshooting and simple repairs as authorized in your product documentation, or as directed by the online or telephone service and support team. Damage due to servicing that is not authorized by Dell is not covered by your warranty. Read and follow the safety instructions that are shipped with your product.

Steps

1. If the system is operational, run the appropriate system diagnostic test. See the Using system diagnostics section for the available diagnostic tests.
If the diagnostic tests indicate a fault, follow the corrective actions provided by the diagnostic tests.
2. If the system is not operational, turn off the system and attached peripherals, and unplug the system from the power source. Wait at least for 10 seconds, and then reconnect the system to the power source.
3. Turn on the system and attached peripherals, and note the messages on the screen.
If an error message is displayed indicating a fault with a specific memory module, go to step 12.
4. Enter System Setup, and check the system memory setting. Make any changes to the memory settings, if needed.

If the memory settings match the installed memory but the problem still persists, go to step 12.

5. Turn off the system and attached peripherals, and disconnect the system from the electrical outlet.
6. Remove the system cover.
7. Check the memory channels and ensure that they are populated correctly.

 **NOTE: See the system event log or system messages for the location of the failed memory module. Reinstall the memory device.**

8. Reseat the memory modules in their sockets.
9. Install the system cover.
10. Enter System Setup and check the system memory setting.
If the problem is not resolved, proceed with step 11.
11. Remove the system cover.
12. If a diagnostic test or error message indicates a specific memory module as faulty, swap or replace the module with a known working memory module.
13. To troubleshoot an unspecified faulty memory module, replace the memory module in the first DIMM socket with a module of the same type and capacity.
If an error message is displayed on the screen, this may indicate a problem with the installed DIMM type(s), incorrect DIMM installation, or defective DIMM(s). Follow the on-screen instructions to resolve the problem.
14. Install the system cover.
15. As the system boots, observe any error message that is displayed and the diagnostic indicators on the front of the system.
16. If the memory problem persists, repeat step 12 through step 15 for each memory module installed.

Next steps

If the problem persists, see the Getting help section.

Related reference

[Getting help](#)

[Using system diagnostics](#)

Troubleshooting an internal USB key

Prerequisites

 **CAUTION: Many repairs may only be done by a certified service technician. You should only perform troubleshooting and simple repairs as authorized in your product documentation, or as directed by the online or telephone service and support team. Damage due to servicing that is not authorized by Dell is not covered by your warranty. Read and follow the safety instructions that are shipped with your product.**

Steps

1. Enter System Setup and ensure that the **USB key port** is enabled on the **Integrated Devices** screen.
2. Turn off the system and attached peripherals, and disconnect the system from the electrical outlet.
3. Remove the system cover.
4. Locate the USB key and reseat it.
5. Install the system cover.
6. Turn on the system and attached peripherals, and check if the USB key is functioning.
7. If the problem is not resolved, repeat step 2 and step 3.
8. Insert a known working USB key.
9. Install the system cover.

Next steps

If the problem persists, see the Getting help section.

Related reference

[Getting help](#)

Troubleshooting an SD card

Prerequisites

CAUTION: Many repairs may only be done by a certified service technician. You should only perform troubleshooting and simple repairs as authorized in your product documentation, or as directed by the online or telephone service and support team. Damage due to servicing that is not authorized by Dell is not covered by your warranty. Read and follow the safety instructions that are shipped with your product.

NOTE: Certain SD cards have a physical write-protect switch on the card. If the write-protect switch is turned on, the SD card is not writable.

Steps

1. Enter System Setup, and ensure that the **Internal SD Card Port** is enabled.
2. Turn off the system, including any attached peripherals, and disconnect the system from the electrical outlet.
3. Remove the system cover.

NOTE: When an SD card failure occurs, the internal dual SD module controller notifies the system. On the next restart, the system displayed a message indicating the failure. If redundancy is enabled at the time of SD card failure, a critical alert will be logged and chassis health will degrade.

4. Replace the failed SD card with a new SD card.
5. Install the system cover.
6. Reconnect the system to its electrical outlet and turn on the system, including any attached peripherals.
7. Enter System Setup, and ensure that the **Internal SD Card Port** and **Internal SD Card Redundancy** modes are set to the needed modes.

Verify that the correct SD slot is set as **Primary SD Card**.

8. Check if the SD card is functioning properly.
9. If the **Internal SD Card Redundancy** option is set to **Enabled** at the time of the SD card failure, the system prompts you to perform a rebuild.

NOTE: The rebuild is always sourced from the primary SD card to the secondary SD card.

Troubleshooting an optical drive

Prerequisites

CAUTION: Many repairs may only be done by a certified service technician. You should only perform troubleshooting and simple repairs as authorized in your product documentation, or as directed by the online or telephone service and support team. Damage due to servicing that is not authorized by Dell is not covered by your warranty. Read and follow the safety instructions that are shipped with your product.

Steps

1. Try using a different CD or DVD.
2. If the problem is not resolved, enter System Setup and ensure that the integrated SATA controller and the drive's SATA port are enabled.
3. Run the appropriate diagnostic test.
4. Turn off the system and attached peripherals, and disconnect the system from the electrical outlet.
5. If installed, remove the bezel.
6. Remove the system cover.
7. Ensure that the interface cable is securely connected to the optical drive and to the controller.

8. Ensure that a power cable is properly connected to the drive.
9. Install the system cover.

Next steps

If the problem persists, see the Getting help section.

Related reference

[Getting help](#)

Troubleshooting a tape backup unit

Prerequisites

 **CAUTION:** Many repairs may only be done by a certified service technician. You should only perform troubleshooting and simple repairs as authorized in your product documentation, or as directed by the online or telephone service and support team. Damage due to servicing that is not authorized by Dell is not covered by your warranty. Read and follow the safety instructions that are shipped with your product.

Steps

1. Use a different tape cartridge.
2. Ensure that the device drivers for the tape backup unit are installed and are configured correctly. See your tape drive documentation for more information about device drivers.
3. Reinstall the tape-backup software as instructed in the tape-backup software documentation.
4. Ensure that the interface cable of the tape drive is connected to the external port on the controller card.
5. Perform the following steps to ensure that the controller card is properly installed:
 - a) Turn off the system and attached peripherals, and disconnect the system from the electrical outlet.
 - b) Remove the system cover.
 - c) Reseat the controller card in the expansion card slot.
 - d) Install the system cover.
 - e) Turn on the system and attached peripherals.
6. Run the appropriate diagnostic test. For more information, see the Using system diagnostics.

Next steps

If you cannot resolve the problem, see the Getting help section.

Related reference

[Getting help](#)

Troubleshooting a hard drive

Prerequisites

 **CAUTION:** This troubleshooting procedure can erase data stored on the hard drive. Before you proceed, back up all files on the hard drive.

 **CAUTION:** Many repairs may only be done by a certified service technician. You should only perform troubleshooting and simple repairs as authorized in your product documentation, or as directed by the online or telephone service and support team. Damage due to servicing that is not authorized by Dell is not covered by your warranty. Read and follow the safety instructions that are shipped with your product.

Steps

1. Run the appropriate diagnostic test. See the Using system diagnostics section.

Depending on the results of the diagnostics test, proceed as needed through the following steps.

2. If your system has a RAID controller and your hard drives are configured in a RAID array, perform the following steps:
 - a) Restart the system and press F10 during system startup to run the Dell Lifecycle Controller, and then run the Hardware Configuration wizard to check the RAID configuration.
See the Dell Lifecycle Controller documentation or online help for information about RAID configuration.
 - b) Ensure that the hard drives are configured correctly for the RAID array.
 - c) Take the hard drive offline and reseal the drive.
 - d) Exit the configuration utility and allow the system to boot to the operating system.
3. Ensure that the needed device drivers for your controller card are installed and are configured correctly. See the operating system documentation for more information.
4. Restart the system and enter the System Setup.
5. Verify that the controller is enabled and the drives are displayed in the System Setup.

Next steps

If the problem persists, see the Getting help section.

Related reference

[Getting help](#)

[Using system diagnostics](#)

Troubleshooting a storage controller

CAUTION: Many repairs may only be done by a certified service technician. You should only perform troubleshooting and simple repairs as authorized in your product documentation, or as directed by the online or telephone service and support team. Damage due to servicing that is not authorized by Dell is not covered by your warranty. Read and follow the safety instructions that are shipped with your product.

NOTE: When troubleshooting a SAS or PERC controller, see the documentation for your operating system and the controller.

1. Run the appropriate diagnostic test. See the Using system diagnostics section.
2. Turn off the system and attached peripherals, and disconnect the system from the electrical outlet.
3. Remove the system cover.
4. Verify that the installed expansion cards are compliant with the expansion card installation guidelines.
5. Ensure that each expansion card is firmly seated in its connector.
6. Install the system cover.
7. Reconnect the system to the electrical outlet, and turn on the system and attached peripherals.
8. If the problem is not resolved, turn off the system and attached peripherals, and disconnect the system from the electrical outlet.
9. Remove the system cover.
10. Remove all expansion cards installed in the system.
11. Install the system cover.
12. Reconnect the system to the electrical outlet, and turn on the system and attached peripherals.
13. Run the appropriate diagnostic test. See the Using system diagnostics section. If the tests fail, see the Getting help section.
14. For each expansion card you removed in step 10, perform the following steps:
 - a. Turn off the system and attached peripherals, and disconnect the system from the electrical outlet.
 - b. Remove the system cover.
 - c. Reinstall one of the expansion cards.
 - d. Install the system cover.
 - e. Run the appropriate diagnostic test. See the Using system diagnostics section.

If the problem persists, see the Getting help section.

Related tasks

[Removing the system cover](#)

[Removing an expansion card from expansion card riser 2 or 3](#)

[Installing an expansion card into the expansion card riser 2 or 3](#)

Related reference

[Getting help](#)

[Using system diagnostics](#)

[Safety instructions](#)

Troubleshooting expansion cards

Prerequisites

CAUTION: Many repairs may only be done by a certified service technician. You should only perform troubleshooting and simple repairs as authorized in your product documentation, or as directed by the online or telephone service and support team. Damage due to servicing that is not authorized by Dell is not covered by your warranty. Read and follow the safety instructions that are shipped with your product.

NOTE: When troubleshooting an expansion card, you also have to see the documentation for your operating system and the expansion card.

Steps

1. Run the appropriate diagnostic test. See the Using system diagnostics section.
2. Turn off the system and attached peripherals, and disconnect the system from the electrical outlet.
3. Remove the system cover.
4. Ensure that each expansion card is firmly seated in its connector.
5. Install the system cover.
6. Turn on the system and attached peripherals.
7. If the problem is not resolved, turn off the system and attached peripherals, and disconnect the system from the electrical outlet.
8. Remove the system cover.
9. Remove all expansion cards installed in the system.
10. Install the system cover.
11. Run the appropriate diagnostic test. See the Using system diagnostics section.
If the tests fail, see the Getting help section.
12. For each expansion card you removed in step 8, perform the following steps:
 - a) Turn off the system and attached peripherals, and disconnect the system from the electrical outlet.
 - b) Remove the system cover.
 - c) Reinstall one of the expansion cards.
 - d) Install the system cover.
 - e) Run the appropriate diagnostic test. See the Using system diagnostics section.

Next steps

If the problem persists, see the Getting help section.

Related tasks

[Removing the system cover](#)

[Removing an expansion card from expansion card riser 2 or 3](#)

[Installing an expansion card into the expansion card riser 2 or 3](#)

[Installing the system cover](#)

Related reference

[Getting help](#)

[Using system diagnostics](#)

[Safety instructions](#)

Troubleshooting processors

Prerequisites

 **CAUTION:** Many repairs may only be done by a certified service technician. You should only perform troubleshooting and simple repairs as authorized in your product documentation, or as directed by the online or telephone service and support team. Damage due to servicing that is not authorized by Dell is not covered by your warranty. Read and follow the safety instructions that are shipped with your product.

Steps

1. Run the appropriate diagnostics test. See the Using system diagnostics section.
2. Turn off the system and attached peripherals, and disconnect the system from the electrical outlet.
3. Remove the system cover.
4. Ensure that the processor and heat sink are properly installed.
5. Install the system cover.
6. Run the appropriate diagnostic test. See the Using system diagnostics section.
7. If the problem persists, see the Getting help section.

Related tasks

[Removing the system cover](#)

[Installing the system cover](#)

Related reference

[Getting help](#)

[Using system diagnostics](#)

System messages

For a list of event and error messages generated by the system firmware and agents that monitor system components, see the Dell Event and Error Messages Reference Guide at Dell.com/openmanagemanuals > **OpenManage software**.

Warning messages

A warning message alerts you to a possible problem and prompts you to respond before the system continues a task. For example, before you format a hard drive, a message warns you that you may lose all data on the hard drive. Warning messages usually interrupt the task and need you to respond by typing y (yes) or n (no).

 **NOTE:** Warning messages are generated by either the application or the operating system. For more information, see the documentation that shipped with the operating system or application.

Diagnostic messages

The system diagnostic utility will generate messages if there are errors detected when you run diagnostic tests on your system. For more information about system diagnostics, see the Using system diagnostics section.

Alert messages

The systems management software generates alert messages for your system. Alert messages include information, status, warning, and failure messages for drive, temperature, fan, and power conditions. For more information, see the systems management software documentation links listed in the Documentation resources section of this manual.

Getting help

Topics:

- [Contacting Dell](#)
- [Documentation feedback](#)

Contacting Dell

Dell provides several online and telephone-based support and service options. If you do not have an active internet connection, you can find contact information about your purchase invoice, packing slip, bill, or Dell product catalog. Availability varies by country and product, and some services may not be available in your area. To contact Dell for sales, technical assistance, or customer-service issues:

Steps

1. Go to **Dell.com/support**.
2. Select your country from the drop-down menu on the lower right corner of the page.
3. For customized support:
 - a) Enter your system Service Tag in the **Enter your Service Tag** field.
 - b) Click **Submit**.
The support page that lists the various support categories is displayed.
4. For general support:
 - a) Select your product category.
 - b) Select your product segment.
 - c) Select your product.
The support page that lists the various support categories is displayed.
5. For contact details of Dell Global Technical Support:
 - a) Click [Global Technical Support](#).
 - b) The **Contact Technical Support** page is displayed with details to call, chat, or e-mail the Dell Global Technical Support team.

Documentation feedback

You can rate the documentation or write your feedback on any of our Dell documentation pages and click **Send Feedback** to send your feedback.