

Dell EMC Host Bus Adapter User's Guide

HBA330 and External 12 Gbps SAS HBA

Notes, cautions, and warnings

 **NOTE:** A NOTE indicates important information that helps you make better use of your product.

 **CAUTION:** A CAUTION indicates either potential damage to hardware or loss of data and tells you how to avoid the problem.

 **WARNING:** A WARNING indicates a potential for property damage, personal injury, or death.

© 2017 - 2018 Dell Inc. or its subsidiaries. All rights reserved. Dell, EMC, and other trademarks are trademarks of Dell Inc. or its subsidiaries. Other trademarks may be trademarks of their respective owners.

Contents

1 Overview.....	5
Dell HBA card specifications.....	7
Supported operating systems.....	8
Related documentation.....	8
2 Features.....	9
LED Port activity.....	9
3 Dell EMC HBA enclosure support.....	10
Dell EMC HBA multipathing using HII.....	10
Dell EMC HBA multipathing using iDRAC.....	10
Dell EMC HBA multipathing using Windows.....	10
Dell EMC HBA multipathing using Linux.....	11
Dell EMC HBA multipathing using VMWare.....	11
Multipathing for the Dell EMC HBA330 MMZ.....	11
Clustering with Dell EMC HBA330 MMZ.....	13
4 Deploying Dell HBA cards.....	14
Removing a 12 Gbps SAS HBA controller.....	14
Installing a 12 Gbps SAS HBA controller.....	15
Cabling a 12 Gbps SAS HBA controller installed on host server to the storage enclosure.....	16
Removing the HBA330 adapter card.....	17
Installing the HBA330 adapter card.....	18
Removing the HBA330 MMZ adapter card.....	19
Installing the HBA330 MMZ adapter card.....	20
Removing the HBA330 MX adapter card.....	21
Installing the HBA330 MX adapter card.....	22
Removing the HBA330 mini monolithic controller.....	23
Installing the HBA330 mini monolithic controller.....	24
5 Driver installation.....	26
Creating the device driver media.....	26
Downloading drivers from the Dell support website.....	26
Downloading drivers from the Dell Systems Service and Diagnostic Tools Media	27
Windows driver installation.....	27
Installing the driver during a Windows Server 2012 R2 and newer installation.....	27
Installing the driver after Windows Server 2012 R2 and newer installation	27
Updating the Dell HBA controller driver for existing Windows Server 2012 R2 and newer.....	28
Linux driver installation.....	29
Installing or updating the RPM driver package with KMOD support.....	29
Installing or updating the RPM driver package with KMP support.....	29

6 BIOS Configuration Utility.....	30
Entering the BIOS Configuration Utility.....	30
Exiting the Configuration Utility.....	30
Setting boot volume.....	31
7 Human Interface Infrastructure configuration utility.....	32
Entering the HII configuration utility.....	32
Exiting the HII configuration utility.....	32
Selecting the Boot device in HII configuration utility.....	32
Selecting physical disk drive operations in HII Boot device.....	33
Navigating to the Dell HBA configuration utility.....	33
Controller management	33
Managing physical disk drives.....	34
Viewing physical disk drive properties.....	34
Selecting physical disk drive operations.....	35
8 Updating the firmware.....	36
9 Getting help.....	37
Contacting Dell.....	37
Documentation feedback.....	37
Locating service tag of your system.....	37

Overview

The Dell EMC Host Bus Adapter (HBA) card family consists of the Dell HBA330 MMZ, Dell HBA330 MX, Dell 12 Gbps SAS HBA controller, Dell HBA330 adapter card and Dell HBA330 mini monolithic card.

- **Dell 12 Gbps SAS HBA controller:** The Dell 12 Gbps SAS HBA controller is a HBA that provides physical disk drive interface with no-RAID capability and is available in low-profile and full-height form factors for external storage. This is a part of the Dell Serial-Attached SCSI (SAS) controller solutions family.

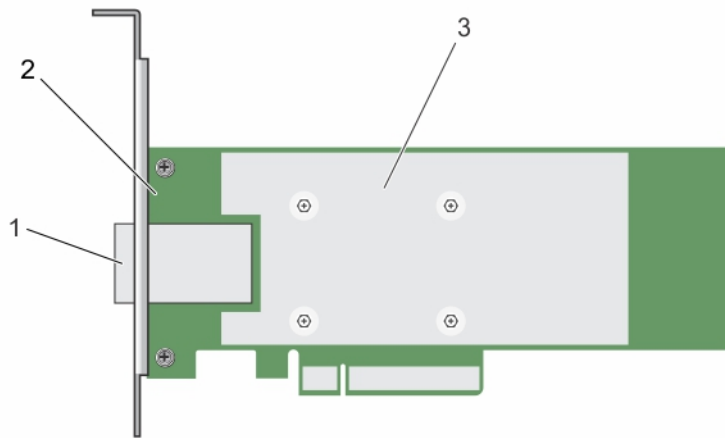

Figure 1. Features of 12 Gbps SAS HBA controller

- | | | | |
|---|------------------------------|---|----------------------------|
| 1 | SAS-external cable connector | 2 | 12 Gbps SAS HBA controller |
| 3 | heat sink | | |

- **Dell HBA330:** The card is available in adapter (low profile and full height) and mini monolithic form factors.

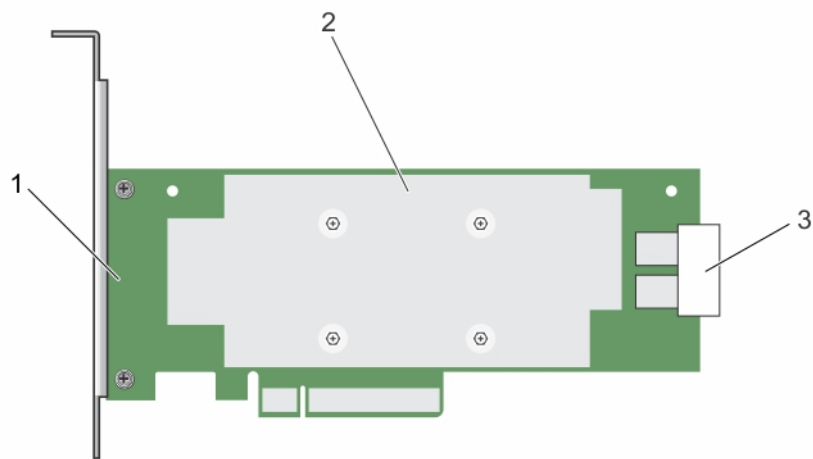

Figure 2. Features of Dell HBA330 adapter card

- | | | | |
|---|---------------------|---|-----------|
| 1 | Dell HBA330 adapter | 2 | heat sink |
| 3 | SAS-cable connector | | |

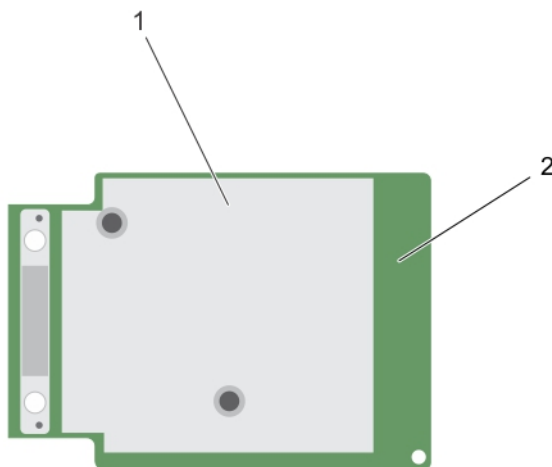

Figure 3. Features of Dell HBA330 mini monolithic card

- | | | | |
|---|-----------|---|----------------------------------|
| 1 | heat sink | 2 | Dell HBA330 mini monolithic card |
|---|-----------|---|----------------------------------|

- **Dell HBA330 MX:** The Dell HBA330 is a member of the MX7000 family of controllers, and is used to interface with the internal drives.

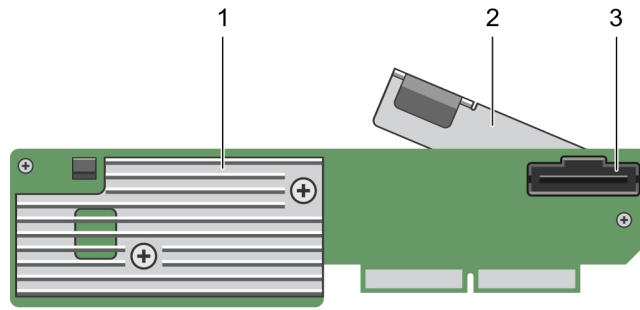

Figure 4. Features of Dell HBA330 MX adapter card

- 1 heat sink
- 2 release lever
- 3 SAS-cable connector

• **Dell HBA330 MMZ:** The Dell HBA330 MMZ is a member of the MX7000 family of controllers and is used to interface with the drives located in the MX5016 storage enclosure.

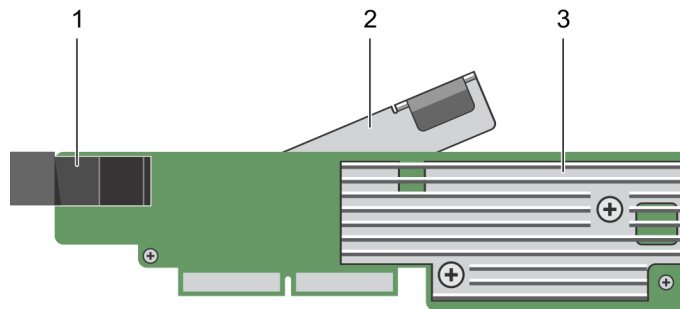

Figure 5. Features of Dell HBA330 MMZ adapter card

- 1 Mezzanine connector
- 2 release lever
- 3 heat sink

Topics:

- [Dell HBA card specifications](#)
- [Supported operating systems](#)
- [Related documentation](#)

Dell HBA card specifications

The table below lists and describes the Dell HBA card specifications.

Table 1. Dell HBA card specifications

Feature	Dell HBA (12 Gbps SAS HBA and HBA330 cards)
Enclosures per port	4 enclosures per port (12 Gbps SAS HBA only)
Processor	Dell Adapter SAS I/O controller, 8-port with LSI 3008 chipset
Battery Backup Unit	No

Feature	Dell HBA (12 Gbps SAS HBA and HBA330 cards)
Non-Volatile cache	None
Cache policy	No
Drives Types	3 Gbps SATA, 6 Gbps SATA/SAS, and 12 Gbps SAS
PCIe Support	Generation 3
Non-RAID or pass through mode	Yes
SAS and SATA technology	Yes
 NOTE: SATA is not supported on the Dell HBA330 MMZ and 12 Gbps SAS HBA controller cards.	
Boot support	Yes
Queue depth	9548

Supported operating systems

The Dell HBA controller supports the following operating systems:

- Microsoft
 - Windows Server 2012 R2
 - Windows Server 2016
- VMware
 - ESXi 6.5 update 1
 - ESXi 6.7

 **NOTE: The 12 GBPS SAS HBA driver for VMware ESXi is bundled with the VMware ISO image available from Dell. For more information, see Dell.com/virtualizationsolutions.**

- Linux
 - Red Hat Enterprise Linux 6.9
 - Red Hat Enterprise Linux 7.5
 - SUSE Linux Enterprise Server version 12.3
- Ubuntu
 - Ubuntu 16.04.4
 - Ubuntu 18.04

Related documentation

 **NOTE:**

- For all storage controllers and PCIe SSD documents, go to Dell.com/storagecontrollermanuals.
- For all Dell OpenManage documents, go to Dell.com/openmanagemanuals.
- For all operating system documents, go to Dell.com/operatingsystemmanuals.
- For all PowerEdge documentation, go to Dell.com/poweredgemanuals.
- For all PowerVault documentation, go to Dell.com/powervaultmanuals.

Features

Dell HBA cards support the following features.

LED Port activity

The 12 Gbps SAS HBA controller is equipped with port activity or status LEDs. The LEDs enable you to quickly determine the status of an external SAS port. Each x4 connector has its own set of LEDs.

NOTE: The HBA330 card does not have LED port indicators.

The following table describes the color of the LEDs and corresponding SAS port state.

Table 2. x4 Connector LEDs Description

LED Color	SAS Port State
Off	Indicates one of the following: <ul style="list-style-type: none"> • Power is off. • Port has been reset. • Either all links in the port are disconnected or the cable is disconnected.
Green	All links in the port are connected and functional.
Amber	One or more links in the port is not connected. This is applicable only in a wide port configuration.

Dell EMC HBA enclosure support

When set up for multipath systems, the HBA330 MMZ and the 12 Gbps SAS controllers may access physical drives through multiple paths to provide redundancy and load balance to the drives. However, the controller does not manage these paths; this function is controlled by the multipath layer in the host operating system. As a result, in a multipath configuration, each separate path to a drive is treated as an independent drive and a single drive may be presented in the operating system as multiple drives. In order to avoid complications from having multiple paths to a drive, path management software is necessary to map these multiple paths to the same single drive. This section will cover multipath management options for different operating systems and management interfaces.

Topics:

- [Dell EMC HBA multipathing using HII](#)
- [Dell EMC HBA multipathing using iDRAC](#)
- [Dell EMC HBA multipathing using Windows](#)
- [Dell EMC HBA multipathing using Linux](#)
- [Dell EMC HBA multipathing using VMWare](#)
- [Multipathing for the Dell EMC HBA330 MMZ](#)
- [Clustering with Dell EMC HBA330 MMZ](#)

Dell EMC HBA multipathing using HII

The 12Gbps SAS controller does not map multiple paths together in HII. As a result, each drive with more than one path is listed twice with different drive enumerations. The HBA330 MMZ maps the two paths to the drives together in HII. Under **Device Configuration**, select the HBA controller. Under **Physical Disk Management > View Physical Disk Properties**, select the physical disk to determine whether it has multiple paths. If the physical disk ID has the letter **M** next to it, the disk has multiple paths that are connected to the system.

Dell EMC HBA multipathing using iDRAC

iDRAC 9 will map paths together for the drives managed by the controller. In iDRAC, you will see each physical drive presented once on the Storage Configuration page. To determine if your drive is in a multipath configuration, select **Storage > Enclosures** and expand the enclosure that is in a redundant path setup. iDRAC 8 lists the paths separately, so each drive in a multipath configuration will be listed multiple times.

Dell EMC HBA multipathing using Windows

To enable Multipath I/O (MPIO) for Windows Server 2012 R2 or Windows Server 2016:

- 1 Open the **Server Manager**.
- 2 Under **Manage**, select **Add Roles and Features**.
- 3 Follow the steps in the **Add Roles and Features Wizard** until you reach the **Features** step. Then, select the **Multipath I/O** feature for installation.
- 4 Complete the steps in the **Add Roles and Features Wizard** to complete the installation.
- 5 In the **Server Manager**, select **Tools > MPIO**.
- 6 Under the **Discover Multipaths** tab, select the **Add support for SAS devices** option and select **Ok**.
Restart the system.
- 7 To check that MPIO is enabled and managing the HBA Drives, open **Device Manager** and select **Disk Drives**.

Drives that are accessible are now listed as a **Multipath Disk Device**.

- 8 Right-click on a multipath disk and select **Properties**.
- 9 Click on the **MPIO**. You can set MPIO policies and check whether both the paths to the drive are active. If configured properly, both the paths will display **Active/Optimised** under the **This device has the following paths** section. If only one path is listed, check the system storage assignment and hardware configuration.

Dell EMC HBA multipathing using Linux

For information about configuring Dell EMC HBA multipathing using Linux, see the Linux administration documentation. To check for multipath status, use the **Multipath-l** commands to display path information.

Dell EMC HBA multipathing using VMWare

ESXi by default provides the VMWare Native Multipathing Plug-In, which automatically maps paths and manages drives in a multipath configuration. For more information, refer to the VMWare documentation on NMP.

Multipathing for the Dell EMC HBA330 MMZ

The HBA330 MMZ is the HBA controller for the PowerEdge MX740c and MX840c compute sleds. It is used as an interface in a multipath topology with the MX5016s storage sled for the MX7000 modular system. The following illustration displays the multipath topology for the PowerEdge MX7000.

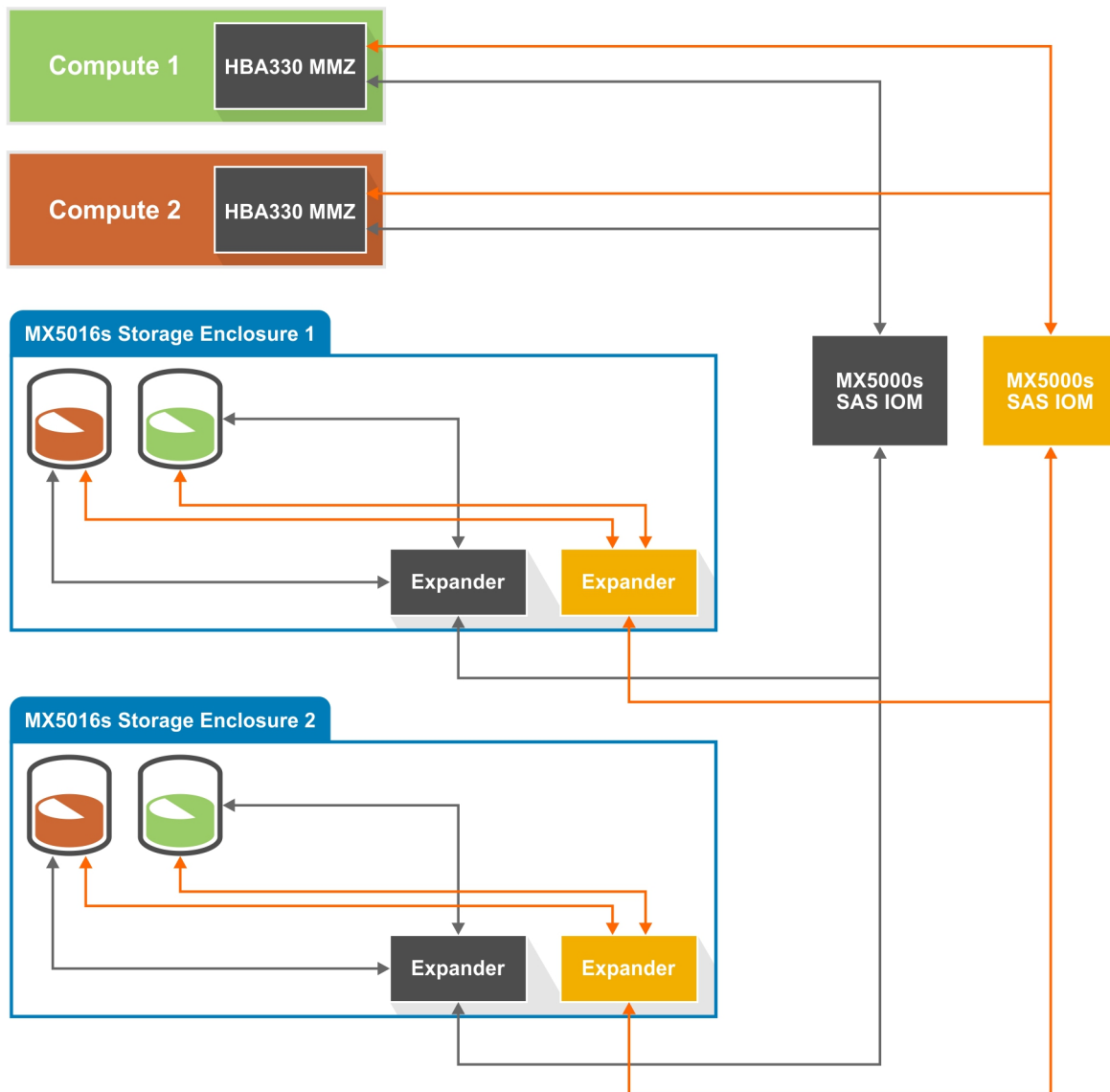

Figure 6. Multipath topology for the MX7000 modular system

In this diagram, the HBA330 MMZ resides in the compute sled, and functions as an interface to the SAS topology of the MX7000. The HBA330 MMZ connects to a pair of MX5000 SAS I/O modules (IOMs) that manage connections between the compute and storage sleds in the MX7000. For more information on configuring drive assignments, see the *Dell EMC OpenManage Enterprise Modular User's Guide*.

NOTE: The I/O modules cannot be configured independently.

The HBA330 MMZ is connected to the SAS IOM, which in turn connects to one of the SAS expanders in the storage sled. The expander in the storage sled is then connected to all the drives in the storage sled, providing one path between the HBA330 MMZ, therefore, and a drive in the storage sled. With connections to both SAS IOMs, the HBA330 MMZ has two paths to each drive in a storage sled, allowing for a multipath configuration. If either a SAS IOM or a SAS expander in the storage sled is removed, then a path to the drive is removed from the SAS topology.

Clustering with Dell EMC HBA330 MMZ

Due to its modular design, the MX7000, is an ideal solution for configuring a clustered system with multiple compute nodes and storage sleds within the same MX7000 chassis. Each compute node will need an HBA330 MMZ and the storage sled will need to be assigned to each compute sled that is a part of the clustering node. For more information on assigning storage sleds to multiple computes, see the *OpenManage Enterprise Modular User's Guide*. Once the storage sled is assigned, however, compute clustering software is required to manage the sharing and reserving of the disks. See the documentation for supported operating systems or clustering solutions for management details.

NOTE: Windows 2016 is the only Dell validated clustered solution for shared storage (the same disks assigned to multiple compute sleds).

Deploying Dell HBA cards

CAUTION: Many repairs may only be done by a certified service technician. You should only perform troubleshooting and simple repairs as authorized in your product documentation, or as directed by the online or telephone service and support team. Damage due to servicing that is not authorized by Dell is not covered by your warranty. Read and follow the safety instructions that came with the system.

This document provides a set of high-level installation and removal instructions for the following Dell HBA card controllers:

- 1 12 Gbps SAS HBA controller
- 2 HBA330 adapter card
- 3 HBA330 MMZ adapter card
- 4 HBA330 MX adapter card
- 5 HBA330 mini monolithic

Topics:

- [Removing a 12 Gbps SAS HBA controller](#)
- [Installing a 12 Gbps SAS HBA controller](#)
- [Cabling a 12 Gbps SAS HBA controller installed on host server to the storage enclosure](#)
- [Removing the HBA330 adapter card](#)
- [Installing the HBA330 adapter card](#)
- [Removing the HBA330 MMZ adapter card](#)
- [Installing the HBA330 MMZ adapter card](#)
- [Removing the HBA330 MX adapter card](#)
- [Installing the HBA330 MX adapter card](#)
- [Removing the HBA330 mini monolithic controller](#)
- [Installing the HBA330 mini monolithic controller](#)

Removing a 12 Gbps SAS HBA controller

CAUTION: Many repairs may only be done by a certified service technician. You should only perform troubleshooting and simple repairs as authorized in your product documentation, or as directed by the online or telephone service and support team. Damage due to servicing that is not authorized by Dell is not covered by your warranty. Read and follow the safety instructions that are shipped with your product.

CAUTION: To ensure protection for the electronic components inside, follow the ElectroStatic Discharge (ESD) guidelines.

- 1 Turn off the system, including any attached peripherals, and disconnect the system from the electrical outlet.

NOTE: For more information about Power Supply Units (PSUs), see your system's Hardware Owner's Manual at Dell.com/poweredgemanuals.

- 2 Disconnect the system from the network.
- 3 Remove the cover of the system.
- 4 Locate the PCIe slot.

NOTE: To avoid damage to the controller, hold the controller by its edges only.

- 5 Remove the screws on the bracket, if any, or use the system's retention clips to remove the controller on the system.
- 6 Remove the connector that attaches the 12 Gbps SAS HBA controller to the system board.
- 7 If applicable, replace the storage controller card and connect the cable. For more information on installing the card, see [Installing the 12 Gbps SAS HBA controller](#).
- 8 Install the system cover.
- 9 Reconnect the power cable(s) and network cables.

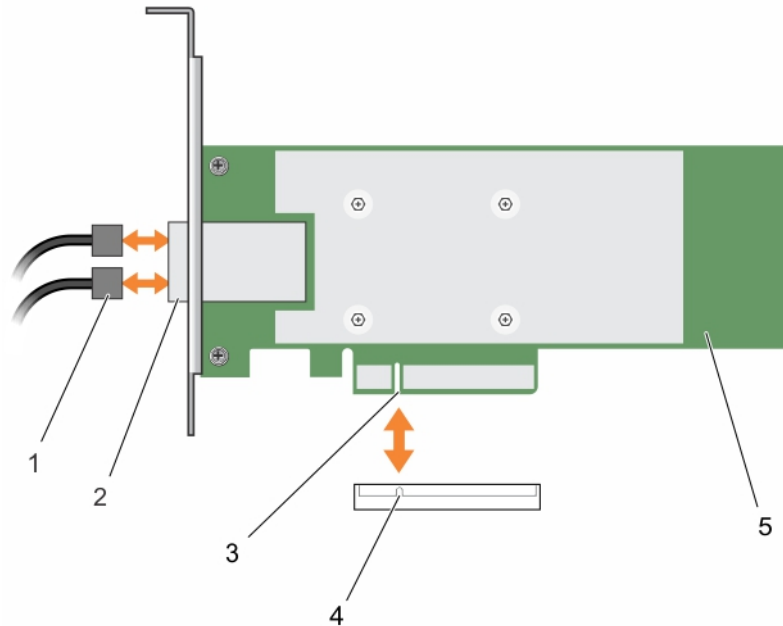

Figure 7. Removing the 12 Gbps SAS HBA controller

- | | |
|----------------------------------|--------------------------------------|
| 1 SAS cables (2) | 2 SAS cable connectors (2) |
| 3 12 Gbps SAS HBA PCIe connector | 4 PCIe connector on the system board |
| 5 12 Gbps SAS HBA controller | |

Installing a 12 Gbps SAS HBA controller

CAUTION: Many repairs may only be done by a certified service technician. You should only perform troubleshooting and simple repairs as authorized in your product documentation, or as directed by the online or telephone service and support team. Damage due to servicing that is not authorized by Dell is not covered by your warranty. Read and follow the safety instructions that are shipped with your product.

CAUTION: To ensure protection for the electronic components inside, follow the ElectroStatic Discharge (ESD) guidelines.

- 1 Unpack your 12 Gbps SAS HBA controller.
- 2 Turn off the system, including any attached peripherals, and disconnect the system from the electrical outlet.

NOTE: For more information about Power Supply Units (PSUs), see your system's Hardware Owner's Manual at [Dell.com/poweredgemanuals](#).

- 3 Disconnect the system from the network.
- 4 Remove the cover of the system.
- 5 Select an appropriate PCIe slot.

NOTE: To avoid damage to the controller, hold the controller by its edges only.

- 6 Align the connector on the 12 Gbps SAS HBA controller with the PCIe slot on the system.
- 7 Press down the controller until the connectors are firmly engaged.
- 8 Tighten the screws on the bracket, if any, or use the system's retention clips to secure the controller on the system.
- 9 Use SAS cable(s) to connect the external tape device or enclosure to the adapter.
- 10 Install the system cover.
- 11 Reconnect the power cable(s) and network cables, and then turn on the system.

Cabling a 12 Gbps SAS HBA controller installed on host server to the storage enclosure

Perform the following steps to connect the 12 Gbps SAS HBA controller to the physical disk drives in storage enclosures:

- 1 Set up the 12 Gbps SAS HBA controller. See [Installing the 12 Gbps SAS HBA controller](#).
- 2 Connect the SAS cables such that the first four enclosures are daisy-chained with one of the enclosures connected to a single port on the controller. The second four enclosures are daisy-chained with one of the enclosures connected to the second port on the controller. See Figure 5.

NOTE: The controller supports up to eight enclosures only.

NOTE: For more information about the single-port and multi-chain configurations, see the PowerVault system-specific manuals at Dell.com/powervaultmanuals.

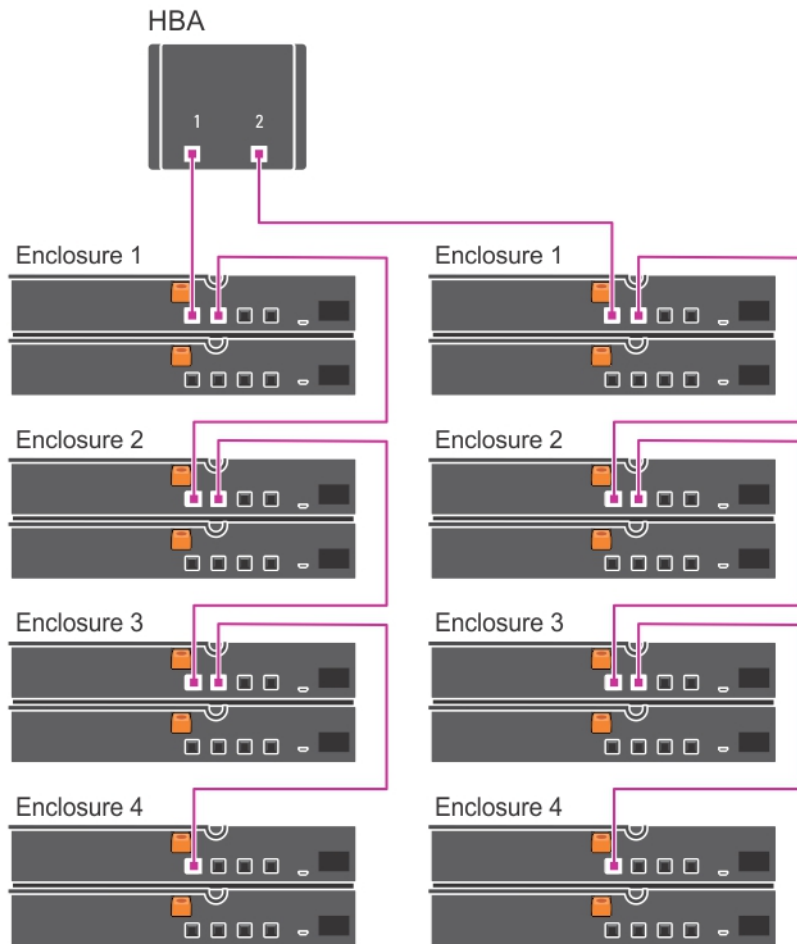

Figure 8. Cabling the 12 Gbps SAS HBA controller to the storage enclosure

Removing the HBA330 adapter card

CAUTION: Many repairs may only be done by a certified service technician. You should only perform troubleshooting and simple repairs as authorized in your product documentation, or as directed by the online or telephone service and support team. Damage due to servicing that is not authorized by Dell is not covered by your warranty. Read and follow the safety instructions that are shipped with your product.

- 1 Turn off the system, including any attached peripherals, and disconnect the system from the electrical outlet and peripherals.

NOTE: It is recommended that you always use a static mat and static strap while working on components in the interior of the system.

- 2 Open the system.
- 3 Locate the HBA card on the system board.

CAUTION: To prevent damage to the card, you must hold the card by its edges only.

- 4 Remove the screws from the bracket, if any, or use the system's retention clips to remove the controller from the system.
- 5 Lift the card to remove it from the connector on the system board.
- 6 Disconnect the SAS cables connected to the card:

- a Press down and hold the metal tab on the SAS cable connector.
- b Pull the SAS cable out of the connector.
- 7 If applicable, replace the storage controller card and connect the cable. For more information on installing the card, see [Installing the HBA330 adapter card](#).
- 8 Close the system.
- 9 Reconnect the system to its electrical outlet and turn the system on, including any attached peripherals.

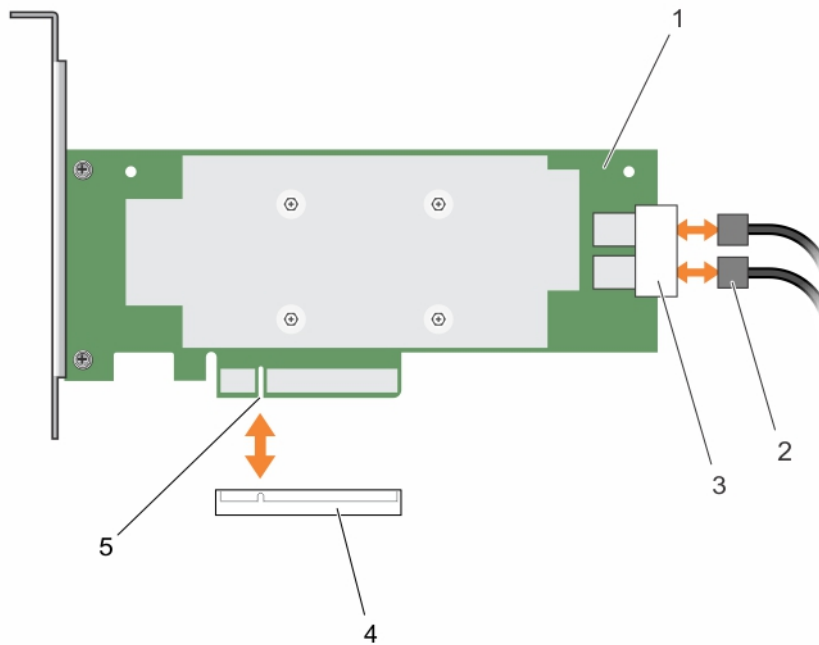

Figure 9. Removing and installing the HBA330 card

- | | | | |
|---|-------------------------------|---|------------------------------------|
| 1 | HBA330 adapter card | 2 | SAS cables (2) |
| 3 | SAS cable connectors (2) | 4 | card connector on the system board |
| 5 | HBA330 adapter card connector | | |

Installing the HBA330 adapter card

⚠ CAUTION: Many repairs may only be done by a certified service technician. You should only perform troubleshooting and simple repairs as authorized in your product documentation, or as directed by the online or telephone service and support team. Damage due to servicing that is not authorized by Dell is not covered by your warranty. Read and follow the safety instructions that are shipped with your product.

- 1 Turn off the system, including any attached peripherals, and disconnect the system from the electrical outlet.

ⓘ NOTE: It is recommended that you always use a static mat and static strap while working on components in the interior of the system.

- 2 Open the system.
- 3 Align the HBA card connector with the card connector on the system board and push the HBA card towards the connector to seat it firmly.
- 4 Tighten the screws on the bracket, if any, or use the system's retention clips to secure the controller on the system.
- 5 Connect the SAS data cable connectors to the card.

ⓘ NOTE: Ensure that you connect the cable according to the connector labels on the cable. The cable does not function properly if reversed.

- 6 Route the SAS data cable through the clip on the card and through the channel on the inner side of the chassis.
- 7 Attach the connector labeled "SAS A" to connector SAS A on the backplane, and attach the connector labeled "SAS B" to connector SAS B on the backplane.
- 8 Close the system.
- 9 Reconnect the system to its electrical outlet and turn the system on, including any attached peripherals.

Removing the HBA330 MMZ adapter card

⚠ CAUTION: Many repairs may only be done by a certified service technician. You should only perform troubleshooting and simple repairs as authorized in your product documentation, or as directed by the online or telephone service and support team. Damage due to servicing that is not authorized by Dell is not covered by your warranty. Read and follow the safety instructions that are shipped with your product.

- 1 Turn off the sled and any attached peripherals, and remove the sled from the MX chassis.

ⓘ NOTE: Perform a graceful shutdown of the sled to ensure any data in the cache is flushed to the disk before the controller is removed.

ⓘ NOTE: It is recommended that you always use a static mat and static strap while working on components in the interior of the system.

- 2 Open the system.
- 3 Locate the HBA card on the system board.
- 4 Using the blue tab, rotate the lever of the controller.
- 5 Firmly pull the lever and the front of the controller to disengage the controller from the connector.
- 6 Lift one end of the card and angle it to disengage from the card connector on the system board.
- 7 Lift the card from the system board.

ⓘ NOTE: To prevent damage to the card, you must hold the card by its edges only.

- 8 Close the sled.
- 9 Insert the sled into the MX chassis and turn on the system and any attached MX chassis peripherals.

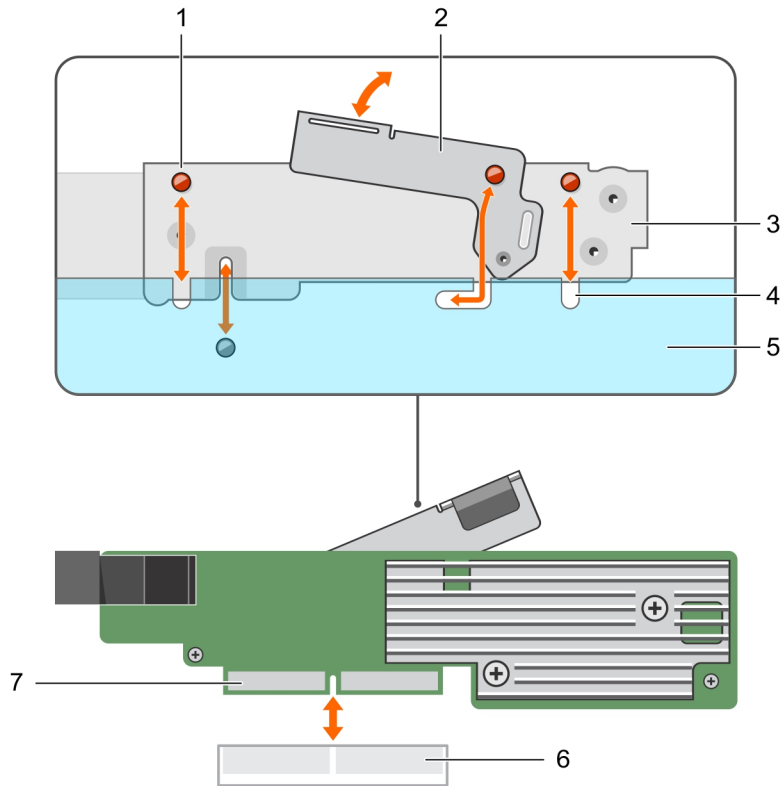

Figure 10. Removing and installing the HBA330 card

- | | | | |
|---|--------------------|---|------------------------------------|
| 1 | bracket notch (3) | 2 | release lever |
| 3 | card bracket | 4 | tabs on the system |
| 5 | system chassis | 6 | card connector on the system board |
| 7 | HBA card connector | | |

Installing the HBA330 MMZ adapter card

⚠ CAUTION: Many repairs may only be done by a certified service technician. You should only perform troubleshooting and simple repairs as authorized in your product documentation, or as directed by the online or telephone service and support team. Damage due to servicing that is not authorized by Dell is not covered by your warranty. Read and follow the safety instructions that are shipped with your product.

- 1 Turn off the sled and any attached peripherals, and remove the sled from the MX chassis.

ⓘ NOTE: It is recommended that you always use a static mat and static strap while working on components in the interior of the system.

- 2 Open the system.
- 3 Align the bracket notches with the tabs on the sides of the system and align the HBA card connector with the connector on the system board.
- 4 Press the HBA card onto the connector until it is firmly seated.
- 5 Press the release lever to secure the card to the sled.
- 6 Close the sled.
- 7 Insert the sled into the MX chassis and turn on the system and any attached MX chassis peripherals.

Removing the HBA330 MX adapter card

CAUTION: Many repairs may only be done by a certified service technician. You should only perform troubleshooting and simple repairs as authorized in your product documentation, or as directed by the online or telephone service and support team. Damage due to servicing that is not authorized by Dell is not covered by your warranty. Read and follow the safety instructions that are shipped with your product.

1 Turn off the sled and any attached peripherals, and remove the sled from the MX chassis.

NOTE: Perform a graceful shutdown of the sled to ensure any data in the cache is flushed to the disk before the controller is removed.

NOTE: It is recommended that you always use a static mat and static strap while working on components in the interior of the system.

2 Open the sled.

3 Locate the HBA card on the system board.

4 Pull up the release lever on the controller and lift the card to remove it from the connector on the system board.

5 Disconnect the SAS cable from the card. To disconnect the cable:

a Press and hold the metal tab on the SAS cable connector.

b Pull the SAS cable out of the connector.

6 Lift one end of the card and angle it to disengage the card from the card connector on the system board.

7 Lift the card from the system board.

NOTE: To prevent damage to the card, you must hold the card by its edges only.

8 Replace the storage controller card and connect the cable. For information on installing the card, see [Installing the HBA330 MX adapter card](#).

9 Close the sled.

10 Insert the sled into the MX chassis and turn on the system and any attached MX chassis peripherals.

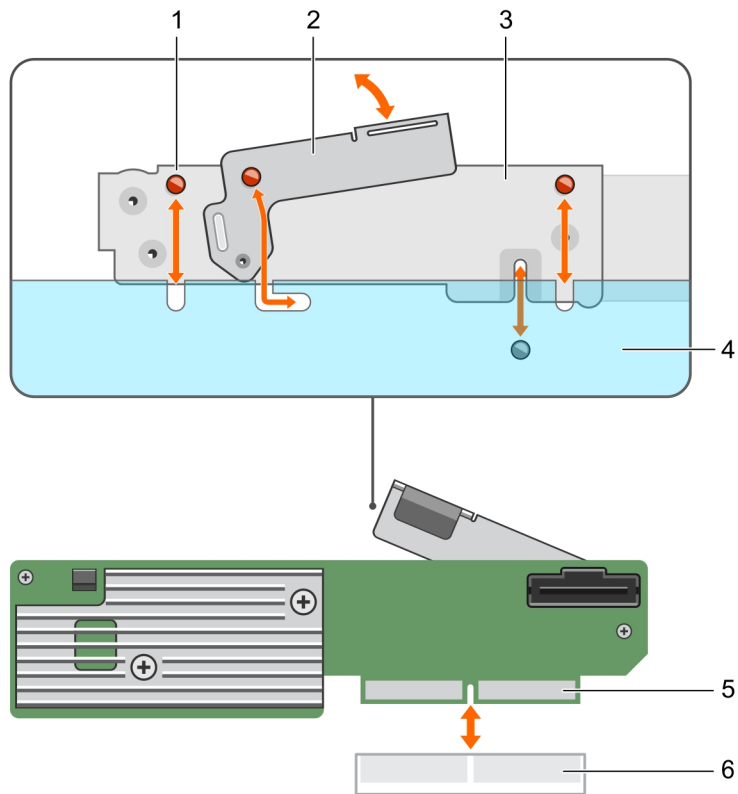

Figure 11. Removing and installing the HBA330 MX card

- | | | | |
|---|--------------------|---|------------------------------|
| 1 | bracket notch (3) | 2 | release lever |
| 3 | card bracket | 4 | system chassis |
| 5 | HBA card connector | 6 | card connector on the system |

Installing the HBA330 MX adapter card

CAUTION: Many repairs may only be done by a certified service technician. You should only perform troubleshooting and simple repairs as authorized in your product documentation, or as directed by the online or telephone service and support team. Damage due to servicing that is not authorized by Dell is not covered by your warranty. Read and follow the safety instructions that are shipped with your product.

- 1 Turn off the sled and any attached peripherals, and remove the sled from the MX chassis.

NOTE: It is recommended that you always use a static mat and static strap while working on components in the interior of the system.

- 2 Open the system.
- 3 Align the bracket notches with the tabs on the sides of the system and align the HBA card connector with the connector on the system board.

NOTE: To prevent damage to the card, you must hold the card by its edges only.

- 4 Press the HBA card onto the connector until it is firmly seated.
- 5 Press the release latch to secure the card to the sled.
- 6 Connect the SAS data cable connectors to the card.

NOTE: Ensure that you connect the cable according to the connector labels on the cable. The cable does not function properly if reversed.

- 7 Route the SAS data cable through the clip on the card and through the channel on the inner side of the chassis.
- 8 Attach the connector labeled "BP SAS" to connector SAS A on the backplane, and attach the connector labeled "CTRL SAS" to SAS-cable on the controller card.
- 9 Close the sled.
- 10 Insert the sled into the MX chassis and turn on the system and any attached MX chassis peripherals.

Removing the HBA330 mini monolithic controller

⚠ CAUTION: Many repairs may only be done by a certified service technician. You should only perform troubleshooting and simple repairs as authorized in your product documentation, or as directed by the online or telephone service and support team. Damage due to servicing that is not authorized by Dell is not covered by your warranty. Read and follow the safety instructions that are shipped with your product.

- 1 Turn off the system, including any attached peripherals, and disconnect the system from the electrical outlet and peripherals.
 - ① **NOTE:** It is recommended that you always use a static mat and static strap while working on components in the interior of the system.
- 2 Open the system.
- 3 Locate the HBA card on the system board
- 4 To disconnect the storage controller cable:
 - a Remove the two screws that secure the cable to the card.
 - b Grasp the cable on both sides of the cable connector, and pull the cable up and away from the HBA card.
- 5 Angle the card so that the other end of the card disengages from the storage-controller card holder on the system board.
- 6 If applicable, replace the storage controller card and connect the cable. For more information on installing the card, see [Installing the HBA330 mini monolithic controller](#).
- 7 Close the system.
- 8 Reconnect the system to its electrical outlet and turn the system on, including any attached peripherals.

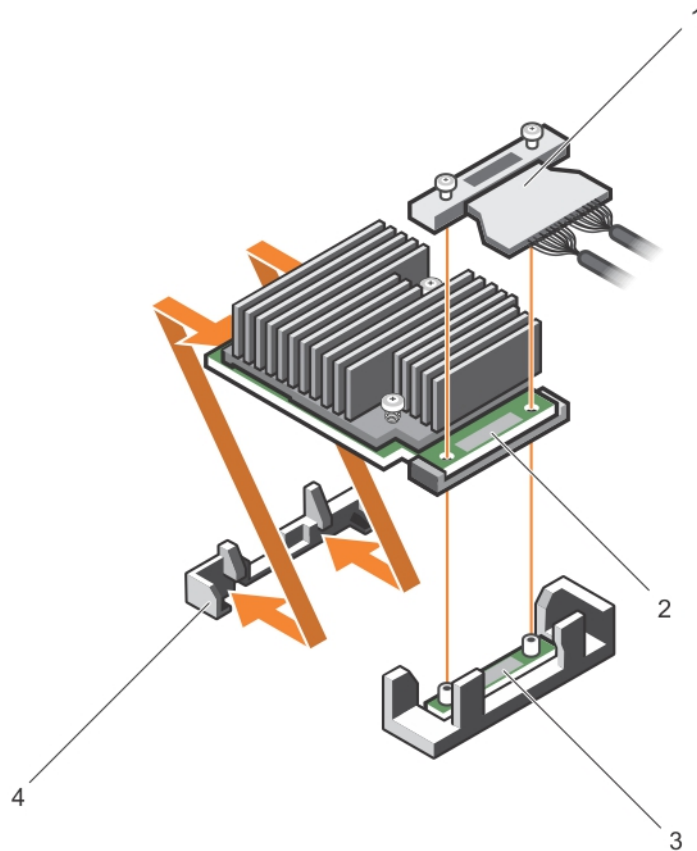

Figure 12. Removing and installing the HBA330 mini monolithic card

- | | | | |
|---|--------------------------------|---|-----------------------------------|
| 1 | storage controller cable | 2 | storage controller card |
| 3 | storage-controller card holder | 4 | storage controller retention hook |

Installing the HBA330 mini monolithic controller

CAUTION: Many repairs may only be done by a certified service technician. You should only perform troubleshooting and simple repairs as authorized in your product documentation, or as directed by the online or telephone service and support team. Damage due to servicing that is not authorized by Dell is not covered by your warranty. Read and follow the safety instructions that are shipped with your product.

- 1 Turn off the system, including any attached peripherals, and disconnect the system from the electrical outlet.

NOTE: It is recommended that you always use a static mat and static strap while working on components in the interior of the system.

- 2 Open the system.
- 3 Locate the storage controller card retention hook on the system board and insert the end of the card at an angle into the storage controller retention hook.

CAUTION: To prevent damage to the card, you must hold the card by its edges only.

- 4 Lower the storage controller card to align the screw holes on the card with the screw holes on the connector.
- 5 Connect the storage controller cable:
 - a Grasp the cable on both sides of the cable connector and connect to the HBA card.

- b Tighten the screws to secure the cable and the card to the system board.
- 6 Connect the SAS data cable connector to the card.

 **NOTE: Ensure that you connect the cable according to the connector labels on the cable. The cable does not function properly if reversed.**

- 7 Route the SAS data cable through the clip on the card and through the channel on the inner side of the chassis.
- 8 Attach the connector labeled "SAS A" to connector SAS A on the backplane, and attach the connector labeled "SAS B" to connector SAS B on the backplane.
- 9 Close the system.
- 10 Reconnect the system to its electrical outlet and turn the system on, including any attached peripherals.

Driver installation

Dell HBA cards require software drivers to operate with the supported operating systems.

This chapter contains the procedures for installing the drivers for the Dell HBA controllers.

NOTE: The drivers for the Dell HBA controller for VMware ESXi is packaged within the VMware ESXi ISO image downloaded from the Dell support site. For more information, see the VMware documentation at Dell.com/virtualizationsolutions.

Two methods for installing a driver discussed in this chapter are:

- **Installing a driver during operating system installation:** Use this method if you are performing a new installation of the operating system and want to include the drivers.
- **Updating existing drivers:** Use this method if the operating system and the Dell HBA controller is already installed, and you want to update to the latest drivers.

NOTE: It is recommended that you update existing operating system drivers after installation. Native driver support is available for Windows 2016, Windows 2012 R2, Windows 2012, and other supported Windows operating systems.

Topics:

- [Creating the device driver media](#)
- [Windows driver installation](#)
- [Linux driver installation](#)

Creating the device driver media

Use one of the following two methods to create the device driver media:

- 1 [Downloading drivers from the Dell support website.](#)
- 2 [Downloading drivers from the Dell Systems Service and Diagnostic Tools Media .](#)

Downloading drivers from the Dell support website

To download drivers from the Dell Support website:

- 1 Go to **Dell.com/support**.
- 2 Enter the service tag of your system in the **Choose by Service Tag to get started** field or select **Choose from a list of all Dell products**.
- 3 Select **System Type**, **Operating System**, and **Category** from the drop-down list.
The drivers that are applicable to your selection are displayed.
- 4 Download the drivers that you require to a USB drive, CD, or DVD.
- 5 During the operating system installation, use the media that you created with the **Load Driver** option to load mass storage drivers. For more information about reinstalling the operating system, see the relevant section for your operating system later in this guide.

Downloading drivers from the Dell Systems Service and Diagnostic Tools Media

To download drivers from the *Dell Systems Service and Diagnostic Tools* media:

- 1 Insert the *Dell Systems Service and Diagnostics Tools* media in your system.
The **Welcome to Dell Service and Diagnostic Utilities** screen is displayed.
- 2 Select your system model and operating system.
- 3 Click **Continue**.
- 4 From the list of drivers displayed, select the driver you require.
- 5 Select the self-extracting zip file and click **Run**.
- 6 Copy the driver to a drive, CD, DVD, or USB drive.
- 7 Repeat the steps 1 to 6 for all the drivers you require.

Windows driver installation

Before you install the Windows driver for the Dell HBA controller, you must first create a device driver media.

- Read the Microsoft *Getting Started* document that shipped with your operating system.
- Ensure that your system has the latest BIOS, firmware, and driver updates. If required, download the latest BIOS, firmware, and driver updates from **Dell.com/support**.
- Create a device driver media using one of the methods listed here:
 - USB drive
 - CD
 - DVD

Installing the driver during a Windows Server 2012 R2 and newer installation

To install the driver:

- 1 Start the system using the Windows Server 2012 R2, or newer media.
- 2 Follow the on-screen instructions until you reach **Where do you want to install Windows Server 2012 R2 or newer** window, and then select **Load driver**.
- 3 The system asks you to insert the media. Insert the installation media and browse to the appropriate location.
- 4 Select **Controller HBA** from the list.
- 5 Click **Next** and continue installation.

Installing the driver after Windows Server 2012 R2 and newer installation

Perform the following steps to configure the driver for the Dell HBA controller on a system that already has Windows installed:

- 1 Turn off the system.
- 2 Install the new Dell HBA controller in the system.

For detailed instructions on installing and cabling the Dell HBA controller in the system, see [Deploying Dell HBA cards](#).

- 3 Turn on the system.
The **Found New Hardware Wizard** screen displays the detected hardware device.
- 4 Click **Next**.
- 5 On the **Locate device driver** screen, select the **Search for a suitable driver for my device** option and click **Next**.
- 6 Browse and select the drivers from the **Locate Driver Files** screen.
- 7 Click **Next**.
The wizard detects and installs the appropriate device drivers.
- 8 Click **Finish** to complete the installation.
- 9 Restart the system when prompted.

Updating the Dell HBA controller driver for existing Windows Server 2012 R2 and newer

NOTE: Close all applications on your system before you update the driver.

- 1 Insert the media (CD, DVD, or USB drive) containing the driver.
- 2 Click **Start > Settings > Control Panel > System**.
The **System Properties** screen is displayed.

NOTE: The path to **System** might vary on the basis of operating system family.

- 3 Click on the **Hardware** tab.
- 4 Click **Device Manager**.
The **Device Manager** screen is displayed.

NOTE: The path to **Device Manager** might vary on the basis of operating system family.

- 5 Expand **SCSI and RAID Controllers** by double-clicking the entry or by clicking the plus (+) symbol next to **SCSI and RAID Controller**.

NOTE: In Windows Server 2012, Windows Server 2012 R2, and Windows Server 2016, the Dell HBA controller is listed under **Storage Controllers**.

- 6 Double-click the controller for which you want to update the driver.
- 7 Click the **Driver** tab and click **Update Driver**.
The screen to update the device driver wizard is displayed.
- 8 Select **Install from a list or specific location**.
- 9 Click **Next**.
- 10 Follow the steps in the wizard and browse to the location of the driver files.
- 11 Select the INF file from the driver media (CD, DVD, or other media).
- 12 Click **Next** and continue the installation steps in the wizard.
- 13 Click **Finish** to exit the wizard and reboot the system for the changes to take place.

NOTE: Dell provides the **Dell Update Package (DUP)** to update drivers on systems running Windows Server 2012 R2 and newer operating system. DUP is an executable application that updates drivers for specific devices. DUP supports command line interface and silent execution. For more information, see Dell.com/support.

Linux driver installation

- ① **NOTE:** The driver update disk (DUD) images are created only for those operating system releases in which the native (in-box) driver is insufficient for installation. In the event that an operating system is being installed with a corresponding DUD image, follow the instructions below. If not, proceed with using the native device driver and then skip to the topic [Installing or Updating the RPM Driver Package With DKMS Support](#).

Installing or updating the RPM driver package with KMOD support

- ① **NOTE:** This procedure is applicable for Red Hat Enterprise Linux 6.5 SP2.

Perform the following steps to install the RPM package with KMOD support:

- 1 Expand the gzipped tarball driver release package.
- 2 Install the driver package using the command: `rpm -ihv lsi-mpt3sas-kmp-default-`.

- ① **NOTE:** Use `rpm -Uvh <package name>` when upgrading an existing package.

- 3 If the previous device driver is in use, you must restart the system for the updated driver to take effect.
- 4 Verify that the driver is loaded with the following system commands: `modinfo mpt3sas`.

Installing or updating the RPM driver package with KMP support

- ① **NOTE:** This procedure is applicable for SUSE Enterprise Linux 11 and SLES 11 SP3, which is first supported.

Perform the following steps to install the RPM package with KMP support:

- 1 Expand the gzipped tarball driver release package.
- 2 Install the driver package using the command: `rpm -ihv lsi-mpt3sas-kmp-default-<version>.rpm`.

- ① **NOTE:** Use `rpm -Uvh <package name>` when updating an existing package.

- 3 If the previous device driver is in use, you must reboot the system for the updated driver to take effect.
- 4 Verify that the driver is loaded with the following system commands: `lsi-mpt3sas`.

Upgrading the Kernel

When upgrading to a new kernel, you must reinstall the DKMS-enabled driver packages. Perform the following steps to update or install the driver for a new kernel:

- 1 At a **terminal** window, type the following: `dkms build -m <module_name> -v <module version> -k <kernel version> dkms install -m <module_name> -v <module version> -k <kernel version>`.
- 2 To check if the driver is successfully installed in the new kernel, type: `dkms status`.
A message similar to the following is displayed: `<driver name>, <driver version>, <new kernel version>: installed`.
- 3 If the previous device driver is in use, you must restart the system for the updated driver to take effect.

BIOS Configuration Utility

The **BIOS Configuration Utility** Ctrl+C, is a storage management application embedded on Dell HBA cards. The Ctrl+C function is independent of the operating system.

- ① **NOTE:** You cannot boot your system using external attached storage devices.
- ① **NOTE:** When you boot your system, press Ctrl+C to load the BIOS configuration Utility for the HBA controller. The BIOS configuration Utility loads only after you select the boot device. The BIOS Configuration Utility Ctrl+C is not supported for HBA330 MMZ and HBA330 MX.
- ① **NOTE:** Use the BIOS Configuration Utility Ctrl+C for initial setup and disaster recovery. You can use advanced features through the Dell OpenManage storage management application.
- ① **NOTE:** Using Ctrl+C to enter the BIOS Configuration Utility will automatically cause the boot order to change. It is recommended that you re-configure the boot order after using Ctrl+C.

The following sections provide information about using the **BIOS Configuration Utility** Ctrl+C. For more information, see the online help option by pressing F1 in the **BIOS Configuration Utility** Ctrl+C.

Topics:

- [Entering the BIOS Configuration Utility](#)
- [Exiting the Configuration Utility](#)
- [Setting boot volume](#)

Entering the BIOS Configuration Utility

Perform the following steps to enter the **BIOS Configuration Utility** Ctrl+C, when you boot the system:

- 1 Turn on the system.
A BIOS screen displays information about the controller and configuration.
- 2 During startup, press Ctrl+C when prompted by the BIOS screen.
- 3 Use the arrow keys to select the HBA controller you want to configure, and press Enter to access the management menus for the controller.

Exiting the Configuration Utility

To exit the **BIOS Configuration Utility** Ctrl+C

- 1 Press Esc on any menu screen.
If there is only one controller, then a dialog box is displayed to confirm your choice.
- 2 Select **OK** to exit and press Enter.
If multiple controllers are present, then the Esc key brings you to the **Controller Selection** screen.
- 3 Press Esc again to reach the exit screen.
A dialog box is displayed to confirm your choice.
- 4 Select **OK** to exit and press Enter.

Setting boot volume

Perform the following steps to set up boot volume in the configuration utility.

- 1 Enter the **BIOS configuration Utility**.

The Device Settings screen displays a list of Dell HBA cards.

NOTE: After entering BIOS configuration Utility Ctrl+C, ensure that you provide all the available devices in the system to set the BIOS boot order as the order is reset everytime you enter the BIOS configuration Utility Ctrl+C.

- 2 Select any of the Dell HBA cards and press Enter. For example, select **Dell HBA330 Mini** and press Enter.

The selected Dell HBA card controller properties are displayed.

- 3 Use the arrow keys to select **SAS Topology** and press Enter.

- 4 Select **Direct Attach Devices** and press Enter.

The list of Direct Attach Devices controller properties and Device Info is displayed.

- 5 To view the list of boot selection keys, press Alt+M.

- 6 To select or deselect a direct attach device as the preferred not device, press Alt+B.

- 7 To select or deselect a device as the alternate boot direct attach device, press Alt+A.

Human Interface Infrastructure configuration utility

The HII configuration utility is a standardized way of viewing and setting a device configuration. The HII configuration utility provides pre-operating system functionality and management for the following:

- Viewing physical device properties.
- Running physical device operations.
- Retrieving debug information.

Topics:

- [Entering the HII configuration utility](#)
- [Exiting the HII configuration utility](#)
- [Selecting the Boot device in HII configuration utility](#)
- [Navigating to the Dell HBA configuration utility](#)
- [Managing physical disk drives](#)

Entering the HII configuration utility

Follow the steps to enter the HII configuration utility:

- 1 Turn on the system.
- 2 Press **F2** during system startup to enter the **System Setup**.
Displays the list of menu on the **System Setup Main Menu** screen.
- 3 Click **Device Settings**.
To access the management menu for the controller, use the arrow keys or the mouse.

 **NOTE:** For more information about all the options, click **Help** that is available on the upper-right corner of the browser screen.

Exiting the HII configuration utility

To exit the HII configuration utility, click the **Exit** button on the upper-right corner in **System Setup menu** of the HII Configuration utility.

 **NOTE:** Clicking **Exit** in any HII configuration utility page takes you back to the main **System Setup** menu.

 **NOTE:** Press **Esc** from any HII configuration utility page to return to the previous page.

Selecting the Boot device in HII configuration utility

- 1 Enter the HII configuration Utility. See [Entering the HII configuration utility](#).
- 2 To change the Boot device, go to **Device Settings** --> **Dell HBA Configuration Utility** --> **Physical Disk Management** --> Select **Physical Disk Operations**.
- 3 To set Boot device, select **PD** from **Select Physical Disk**.
Click on **Yes** for Legacy OpROM Boot Device.

- To remove Boot device, select **PD** from **Select Physical Disk**.

Click on **No** for Legacy OpROM Boot Device.

NOTE: This is a Boot device for Legacy BIOS Mode. If the Server is in UEFI Boot mode, you will need to set your Boot device in System BIOS.

Selecting physical disk drive operations in HII Boot device

The table describes the **Select Physical Disk Operations** screen details:

Menu Item	Description
Select Physical Disk	Allows you to select the physical disk.
legacy OpROM Bootdevice	Allows you to set the selected device as boot device.
Write Cache setting	Allows you to enable or disable.

Navigating to the Dell HBA configuration utility

- Enter the HII configuration utility. See [Entering the HII configuration utility](#).
The **Device Settings** screen displays a list of NIC ports and the Dell HBA configuration utility.
- To access the Dell HBA configuration utility, click **Dell HBA configuration utility**.
The list of **Configuration Options** appears:
 - Controller management
 - Physical disk management

Controller management

Controller management allows you to configure, manage, and view the controller properties.

Viewing the controller properties

View Controller Properties screen allows you to view the controller properties.

In the **System Setup Main Menu**, click **Device Settings > Dell HBA Configuration Utility > Controller Management > View Controller Properties**.

The table describes the fields on the **View Controller Properties** screen:

Menu Item	Description
Controller Name	Indicates the controller name.
Controller Revision	Indicates the controller revision.
PCI ID	Indicates the PCI ID.
PCI Slot Number	Indicates the controller slot numbering.
Host Interface	Indicates the controller type.
Physical Disk Count	Indicates the count of physical drive.
Firmware Type	Indicates the type of firmware.

Menu Item	Description
Firmware Version	Indicates the version of firmware.
Default NVData Version	Indicates the version of default NVData.
Persistent NVData Version	Indicates the version of persistent NVData.

Changing the controller properties

- 1 Enter the **Dell HBA Configuration Utility**. See [Navigating to the Dell HBA configuration utility](#).
- 2 Click **Controller Management > Change Controller Properties**.
You can **Enable** or **Disable** the Legacy BIOS.

Managing physical disk drives

Physical disk drive management allows you to manage, view, and perform the physical disk drive properties.

Viewing physical disk drive properties

View physical disk properties screen allows you to view the physical disk drive properties.

In **System Setup Main Menu**, click **Device Settings > Dell HBA Configuration Utility > Physical Disk Management > View Physical Disk Properties**.

The table describes the fields on the **View Physical Disk Properties** screen:

Table 3. Physical disk properties

Menu Item	Description
Select the Physical Disk	Allows you to select the physical disk
 NOTE: For MMZ cards, the physical disks are enumerated as [IOM Port] : [Chassis Slot] : [Drive Bay Slot]	
· IOM Port:	Either a 0 or 1, indicates which path is detected by the HBA (not an indicator for path activity or health).
· Chassis Slot:	Indicates which slot in the MX7000s the Storage Enclosure for the drive is located in.
· Drive Bay Slot:	Drive Slot in the MX5000s where the drive is located in.
Physical Disk ID	Displays the physical disk ID
State	Displays the current state of the physical disk
Revision	Displays the revision
Device Type	Displays the device type
SAS Address	Displays the SAS address
Disk Cache Setting	Displays the disk cache setting
Size	Displays the total physical storage size of the disk
Disk Protocol	Displays the disk protocol
Serial Number of Disk	Displays the serial number of the physical disk
Unit Serial Number(VPD)	Displays the name of hardware vendor

Menu Item	Description
Hardware Vendor	Displays the name of hardware vendor
Model Number	Displays the model number
Hard Disk Drive RPM	Displays the rpm of the hard disk drive
Physical Link Rate	Displays the physical link rate
Logical Link Rate	Displays the logical link rate.

Selecting physical disk drive operations

- 1 Start the **Dell HBA Configuration Utility**. See [Navigating to the Dell HBA configuration utility](#).
- 2 Click **Physical Disk Management > Select Physical Disk Operations**.

The table describes the **Select Physical Disk Operations** screen details:

Menu Item	Description
Select Physical Disk	Allows you to select the physical disk.
Start Locate/Blink	Allows you to activate the driver's LED.
Stop Locate/Unblink	Allows you to deactivate the driver's LED.

Updating the firmware

Perform the below procedures to download and run DUP to update the firmware:

- 1 Navigate to **Dell.com/support**.
- 2 Enter your system Service Tag and click **Submit**.
The Product Support page is displayed.
- 3 Click **Driver and Downloads**.
- 4 Select the operating system, category, and the update importance.
The list of applicable updates are displayed.
- 5 Click **Download**.
- 6 When the download is complete, run DUP by double-clicking the filename.

NOTE: You can also download a different file format from the File Title column by selecting a file format for the DUP and clicking it. In case you want to download more than one file type, you must do it one at a time.

NOTE: You can also download a DUP or group of DUPs using Dell Repository Manager. For more information, see the Dell Repository Manager User's Guide.

- 7 Read the update information displayed in the DUP window.
- 8 Check the DUP inventory report for package version and installed versions of component.
- 9 Click **Install** to install the DUP.

NOTE: For more information about updating the firmware on system supporting different operating systems, see Dell.com/openmanagemanuals.

NOTE: Downgrade of firmware using iDRAC/LC is not supported.

NOTE: Downgrade using DUP in the operating system to version 13.15.03.05 firmware is supported, anything lower than this version will fail.

Getting help

You can get help with your Dell product by contacting Dell, or send feedback on product documentation.

Contacting Dell

NOTE: If you do not have an active Internet connection, you can find contact information on your purchase invoice, packing slip, bill, or Dell product catalog.

Dell provides several online and telephone-based support and service options. Availability varies by country and product, and some services may not be available in your area. To contact Dell for sales, technical support, or customer service issues:

Go to Dell.com/contactdell.

Documentation feedback

Click the **Feedback** link in any of the Dell documentation pages, fill out the form, and click **Submit** to send your feedback.

Locating service tag of your system

Your system is identified by a unique Express Service Code and Service Tag number. The Express Service Code and Service Tag are found on the front of the system by pulling out the information tag. Alternatively, the information may be on a sticker on the chassis of the system. This information is used by Dell to route support calls to the appropriate personnel.