

Dell EMC XC740xd2

Installation and Service Manual

Notes, cautions, and warnings

 **NOTE:** A NOTE indicates important information that helps you make better use of your product.

 **CAUTION:** A CAUTION indicates either potential damage to hardware or loss of data and tells you how to avoid the problem.

 **WARNING:** A WARNING indicates a potential for property damage, personal injury, or death.

© 2019 Dell Inc. or its subsidiaries. All rights reserved. Dell, EMC, and other trademarks are trademarks of Dell Inc. or its subsidiaries. Other trademarks may be trademarks of their respective owners.

1 About this document.....	6
2 Dell EMC XC740xd2 system overview.....	7
Front view of the system.....	7
Control panels.....	8
Rear view of the system.....	8
Inside the system.....	9
Locating the information tag of your system.....	9
System Information Label.....	11
3 Initial system setup and configuration.....	14
Setting up your system.....	14
iDRAC configuration.....	14
Options to set up iDRAC IP address.....	14
Log in to iDRAC.....	15
Options to install the operating system.....	15
Methods to download firmware and drivers.....	15
Downloading drivers and firmware.....	15
4 Pre-operating system management applications.....	17
Options to manage the pre-operating system applications.....	17
System Setup.....	17
Viewing System Setup.....	17
System Setup details.....	17
System BIOS.....	18
iDRAC Settings utility.....	33
Device Settings.....	34
Dell Lifecycle Controller.....	34
Embedded system management.....	34
Boot Manager.....	34
Viewing Boot Manager.....	34
Boot Manager main menu.....	34
One-shot UEFI boot menu.....	35
System Utilities.....	35
PXE boot.....	35
5 Installing and removing system components.....	36
Installing and removing system components.....	36
Safety instructions.....	36
Before working inside your system.....	36
After working inside your system.....	37
Recommended tools.....	37
Front bezel.....	37
System cover.....	39

Air shroud.....	41
Internal PERC riser.....	43
Cooling fans.....	48
Intrusion switch.....	52
Drive bay.....	54
Drives.....	55
Drive backplane bracket.....	62
Bay intrusion switch.....	65
Drive backplane.....	67
Cable routing.....	72
System memory.....	73
Processor and heat sink.....	79
Expansion cards and expansion card risers.....	86
M.2 SSD module.....	101
IDSDM / vFlash module.....	103
LOM riser card.....	107
System battery	109
Power supply unit.....	111
Power interposer board.....	114
System board.....	116
Trusted Platform Module.....	120
Upgrading the Trusted Platform Module.....	120
Initializing TPM for BitLocker users.....	121
Initializing the TPM 1.2 for TXT users.....	122
Initializing the TPM 2.0 for TXT users.....	122
Cable chain assembly.....	122
Control panel.....	128
6 Jumpers and connectors	135
System board connectors.....	135
System board jumper settings.....	136
Disabling forgotten password.....	137
7 Technical specifications.....	138
Chassis dimensions.....	138
System weight.....	139
Processor specifications.....	139
Supported operating systems.....	139
PSU specifications.....	139
Cooling fans specifications.....	140
System battery specifications.....	140
PCIe Expansion card riser specifications.....	140
Memory specifications.....	142
Storage controller specifications.....	143
Drives.....	143
Ports and connectors specifications.....	143
USB ports specifications.....	143
NIC ports specifications.....	143
Serial connector specifications.....	144

VGA ports specifications.....	144
IDSDM module.....	144
Video specifications.....	144
Environmental specifications.....	145
Standard operating temperature.....	146
Thermal restrictions.....	146
Particulate and gaseous contamination specifications	146
8 Enhanced Preboot System Assessment.....	148
9 Getting help.....	151
Recycling or End-of-Life service information.....	151
Contacting Dell.....	151
Accessing system information by using QRL.....	151
Receiving automated support with SupportAssist	152
10 Documentation resources.....	153

About this document

This document provides an overview about the system, information about installing and replacing components, technical specifications, diagnostic tools, and guidelines to be followed while installing certain components.

Dell EMC XC740xd2 system overview

The Dell EMC XC740xd2 system is a 2U rack server that supports up to:

- Two Intel Xeon Scalable Processor
- 16 DIMM slots
- Two redundant power supply units
- 24 SAS, SATA, Nearline SAS hard drives or SSDs

For more information about supported drives, see the [Drive specifications](#) section.

NOTE: All instances of SAS, SATA hard drives, and SSDs are referred to as drives in this document, unless specified otherwise.

Topics:

- [Front view of the system](#)

Front view of the system



Figure 1. Front view of 24 x 3.5-inch drive system

- | | |
|------------------------|------------------------|
| 1. Left control panel | 2. Drives (12) |
| 3. Right control panel | 4. Right release latch |
| 5. Left release latch | |

Control panels

Left control panel

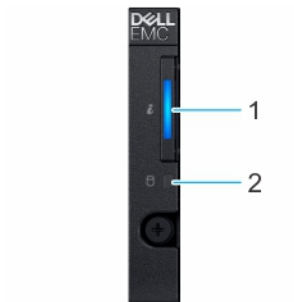

Figure 2. Left control panel view

- 1. System health and system ID indicator
- 2. Drive indicator

Right control panel

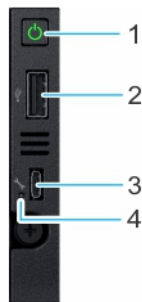

Figure 3. Right control panel view

- 1. Power button
- 2. USB 2.0-compliant port
- 3. Micro USB 2.0-compliant port for iDRAC Direct
- 4. iDRAC LED indicator

NOTE: For more information on the ports, see the [ports and connectors specifications](#) section.

Rear view of the system

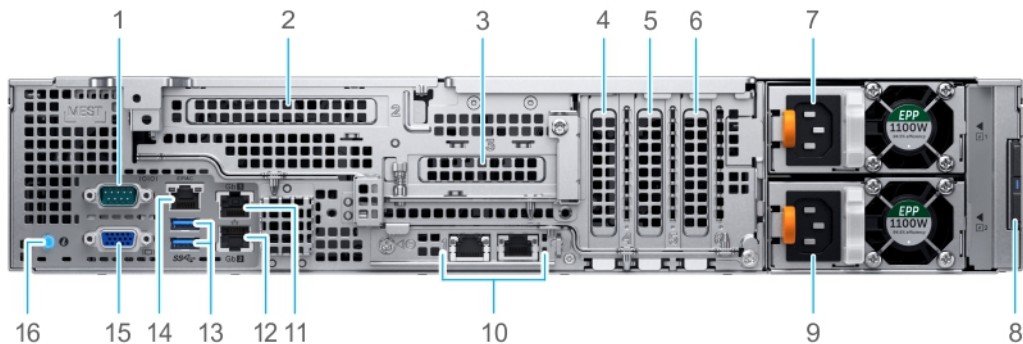

Figure 4. Back panel features of system with butterfly riser

- 1. Serial port
- 2. Butterfly riser full-height (slot 2)

- 3. Butterfly riser low-profile (slot 3)
- 5. Low-profile PCIe expansion card (slot 5)
- 7. Power supply unit (PSU 1)
- 9. Power supply unit (PSU 2)
- 11. Ethernet port (Gb1)
- 13. USB 3.0 port (2)
- 15. VGA port
- 4. Low-profile PCIe expansion card (slot 4)
- 6. Low-profile PCIe expansion card (slot 6)
- 8. Information tag
- 10. LOM ethernet port (2)
- 12. Ethernet port (Gb2)
- 14. iDRAC9 dedicated network port
- 16. System identification button

Inside the system

NOTE: Components that are hot swappable are marked orange and touch points on the components are marked blue.

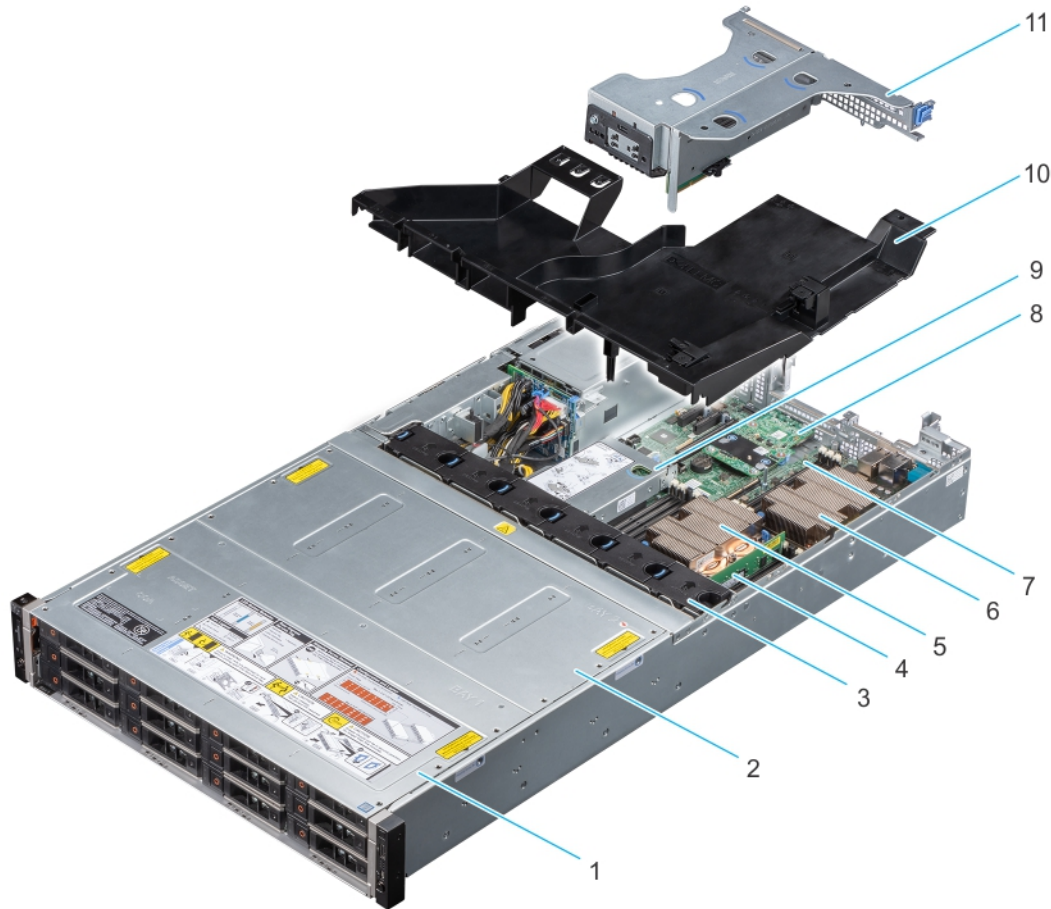

Figure 5. Inside the system with butterfly riser

- 1. Drive bay 1
- 2. Drive bay 2
- 3. Fans (6)
- 4. Memory module
- 5. Processor and heatsink module 1
- 6. Processor and heatsink module 2
- 7. System board
- 8. LOM riser card
- 9. Internal PERC riser
- 10. Air shroud
- 11. Butterfly riser

Locating the information tag of your system

Your system is identified by a unique Express Service Code and Service Tag number. You can view the Express Service Code and Service Tag by pulling out the information tag located on the rear of the system. Alternatively, the information may be on a sticker on the chassis of the system. Alternatively, the information may be on the Mini Enterprise Service Tag (MEST) label on the chassis, on the rear of the system. This information is used by Dell to route support calls to the appropriate personnel.

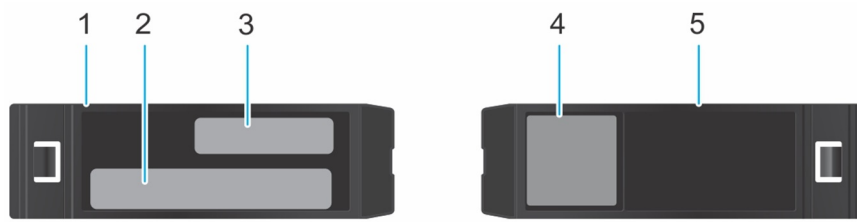

Figure 6. Locating the information tag of your system

1. Information tag (Top view)
2. iDRAC MAC address and iDRAC secure password label
3. Express Service Tag
4. QRL label
5. Information tag (back view)

System Information Label

Service Information

System Touchpoints

■ Hot swap touchpoints: Components with terracotta touchpoints can be serviced while the system is running.

■ Cold swap touchpoints: Components with blue touchpoints require a full system shutdown before servicing.

Mechanical Overview

Top View

Rear View

*Your system may be configured with Riser or non-Riser in PCIe Card Slots. Follow the corresponding instructions.

Electrical Overview

System Board Connections

1 System Power	15 TPM	26 Fan 6
2 SATA_C	16 PCIe Card Slot 4 (CPU 2)	27 DIMMs For CPU 1 Channels 0, 1, 2
3 SATA_B	17 LOM Riser Card	28 CPU 1
4 PIB Signal 1	18 Backplane Signal 2 (Rear)	29 DIMMs For CPU 1 Channels 3, 4, 5
5 PIB Signal 2	19 PCIe Internal Storage (CPU 1)	30 Fan 5
6 SATA_A	20 Riser 1 (CPU 1)	31 Fan 4
7 iDSM + vFlash	21 DIMMs For CPU 2 Channels 0, 1, 2	32 CPU 1 Power
8 Front USB	22 CPU 2	33 Intrusion Switch
9 ODD/Rear Backplane Power	23 DIMMs For CPU 2 Channels 3, 4, 5	34 Fan 3
10 VGA	24 Slimline (PCIe_A0)	35 Fan 2
11 Internal USB 3.0	25 CPU 2 Power	36 Backplane Signal 1
12 PCIe Card Slot 6 (PCH)		37 Left Control Panel
13 Jumpers		38 Right Control Panel
14 PCIe Card Slot 5 (CPU 1)		

Jumper Settings

Jumper	Setting	Description
PWRD_EN	(default)	BIOS password is enabled.
		BIOS password is disabled. iDRAC local access is unlocked at next AC power cycle. iDRAC password reset is enabled in F2 iDRAC settings menu.
NVRAM_CLR	(default)	BIOS configuration settings retained at system boot.
		BIOS configuration settings cleared at system boot.

Figure 7. XC740xd2 – Service information

Memory Information

⚠ Caution: Memory (DIMMs) and CPUs may be hot during servicing

A6
A5
A10
A4
A9

B3
B2
B1

A7
A1
A8
A2
A3

B4
B5
B6

Memory Population Configuration

Configuration	Sequence
Memory-Optimized	C1{1}, C2{1}, C1{2}, C2{2}, C1{3}, C2{3}
Mirroring	C1{1,2,3,4,5,6}, C2{1,2,3,4,5,6}

Memory Sparring details are documented in the *Installation and Service Manual*.

Scan to see hardware servicing and software setup videos, how-to's, and documentation.

Quick Resource Locator
Dell.com/QRL/Server/PER740xd2

Icon Legend

- Memory Bank
- Power Supply
- System Status
- System Info
- iDRAC Direct(Micro-AB USB)
- Hard Drive Activity
- Push
- Fan
- CPU

Figure 8. Memory information

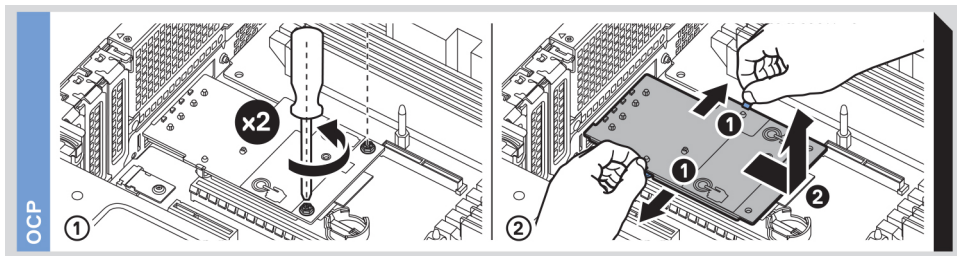

Figure 9. OCP installation

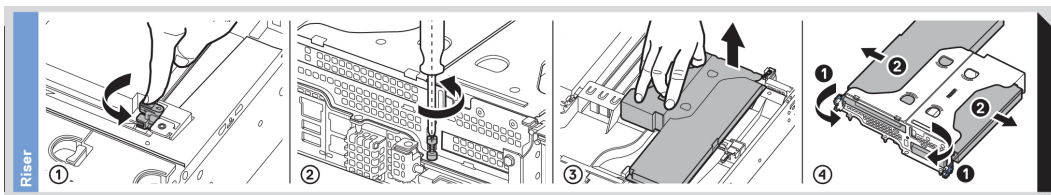

Figure 10. Riser installation

System Tasks Bay Drive Operation

⚠ WARNING Ensure that rails are attached to rack before sliding open the hard drive bay.

⚠ CAUTION Heavy chassis. Two person lift required.

5min **⚠ CAUTION** Drawer should not be in service position for longer than five minutes.

1. Rear Rail Mounting

2. Front Rail Mounting

3. Open

4. Close

Figure 11. Drive Bays Operation

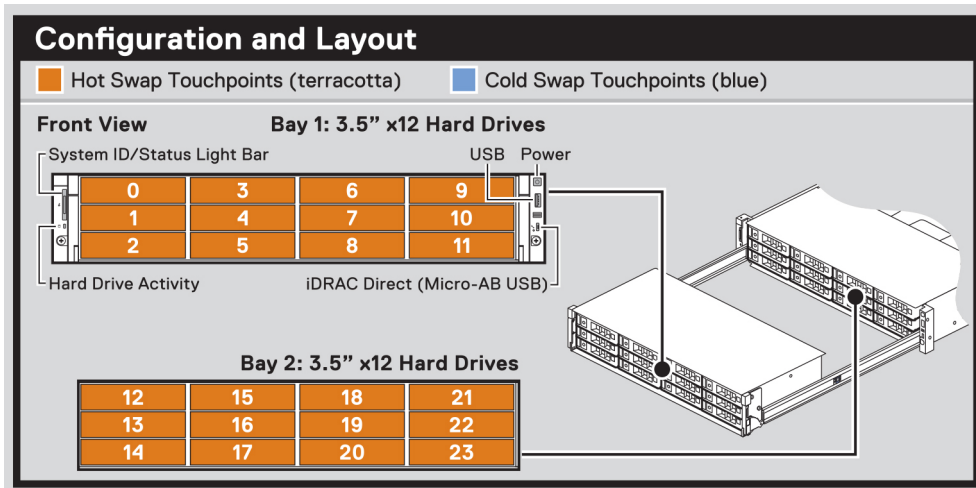

Figure 12. Drive configuration and layout

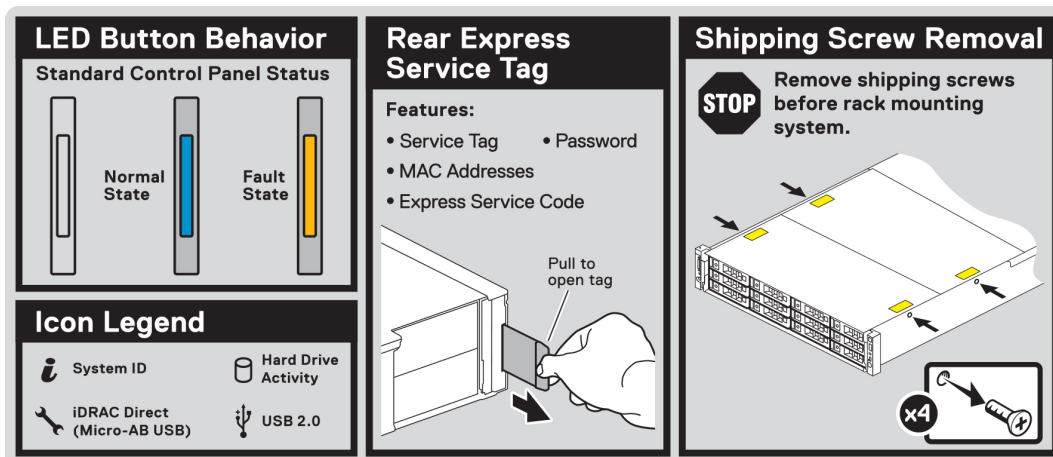

Figure 13. System LED indicator and Express Service Tag

Initial system setup and configuration

Setting up your system

Perform the following steps to set up your system:

Steps

1. Unpack the system.
2. Remove the shipping screws from the sides of the system, before installing it in the rack.

CAUTION: Do not attempt to lift the system by yourself to avoid potential injury. Do not apply uneven force to either end of the system to prevent the chassis from distorting or bending. Keep the system parallel to the ground when lifting and moving it.

3. Install the system into the rack. For more information about installing the system into the rack, see the *Rail Installation Guide* at www.dell.com/xcseriesmanuals.
4. Connect the peripherals to the system.
5. Connect the system to its electrical outlet.
6. Power on the system by pressing the power button or by using iDRAC.
7. Power on the attached peripherals.

For more information about setting up your system, see the *Getting Started Guide* that shipped with your system.

iDRAC configuration

The Integrated Dell Remote Access Controller (iDRAC) is designed to make system administrators more productive and improve the overall availability of Dell systems. iDRAC alerts administrators about system issues and enables them to perform remote system management. This reduces the need for physical access to the system.

Options to set up iDRAC IP address

To enable communication between your system and iDRAC, you must first configure the network settings based on your network infrastructure.

NOTE: For static IP configuration, you must request for it at the time of purchase.

This option is set to **DHCP** by Default. You can set up the IP address by using one of the following interfaces:

Interfaces	Document/Section
iDRAC Settings utility	Dell Integrated Dell Remote Access Controller User's Guide at www.dell.com/xcseriesmanuals
Dell Deployment Toolkit	Dell Deployment Toolkit User's Guide at www.dell.com/openmanagemanuals > OpenManage Deployment Toolkit
Dell Lifecycle Controller	Dell Lifecycle Controller User's Guide at www.dell.com/xcseriesmanuals
iDRAC Direct and Quick Sync 2 (optional)	See Dell Integrated Dell Remote Access Controller User's Guide at www.dell.com/xcseriesmanuals

NOTE: To access iDRAC, ensure that you connect the ethernet cable to the iDRAC9 dedicated network port. You can also access iDRAC through the shared LOM mode, if you have opted for a system that has the shared LOM mode enabled.

Log in to iDRAC

You can log in to iDRAC as:

- iDRAC user
- Microsoft Active Directory user
- Lightweight Directory Access Protocol (LDAP) user

If you have opted for secure default access to iDRAC, you must use the iDRAC secure default password available on the system Information tag. If you have not opted for secure default access to iDRAC, then use the default user name and password `-root` and `calvin`. You can also log in by using your Single Sign-On or Smart Card.

NOTE: You must have the iDRAC credentials to log in to iDRAC.

NOTE: Ensure that you change the default user name and password after setting up the iDRAC IP address.

NOTE: The Intel Quick Assist Technology (QAT) on the Dell EMC XC740xd2 is supported with chipset integration and is enabled through an optional license. The license files are enabled on the sleds through iDRAC.

For more information about drivers, documentation, and white papers on the Intel QAT, see <https://01.org/intel-quickassist-technology>.

For more information about logging in to the iDRAC and iDRAC licenses, see the latest *Integrated Dell Remote Access Controller User's Guide* at www.dell.com/xcseriesmanuals.

You can also access iDRAC by using RACADM. For more information, see the *RACADM Command Line Interface Reference Guide* at www.dell.com/xcseriesmanuals.

Options to install the operating system

If the system is shipped without an operating system, install a supported operating system by using one of the following resources:

Table 1. Resources to install the operating system

Resources	Location
iDRAC	www.dell.com/idracmanuals
Lifecycle Controller	www.dell.com/idracmanuals > Lifecycle Controller
OpenManage Deployment Toolkit	www.dell.com/openmanagemanuals > OpenManage Deployment Toolkit
Dell certified VMware ESXi	www.dell.com/virtualizationsolutions

Methods to download firmware and drivers

You can download the firmware and drivers by using any of the following methods:

Table 2. Firmware and drivers

Methods	Location
From the Dell EMC support site	www.dell.com/support/home
Using Dell Remote Access Controller Lifecycle Controller (iDRAC with LC)	www.dell.com/idracmanuals
Using iDRAC virtual media	www.dell.com/idracmanuals

Downloading drivers and firmware

Dell EMC recommends that you download and install the latest BIOS, drivers, and systems management firmware on your system.

Prerequisites

Ensure that you clear the web browser cache before downloading the drivers and firmware.

Steps

1. Go to www.dell.com/support/home.
2. In the **Drivers & Downloads** section, type the Service Tag of your system in the **Enter a Service Tag or product ID** box, and then click **Submit**.
 **NOTE: If you do not have the Service Tag, select Detect Product to allow the system to automatically detect the Service Tag, or click View products, and navigate to your product.**
3. Click **Drivers & Downloads**.
The drivers that are applicable to your system are displayed.
4. Download the drivers to a USB drive, CD, or DVD.

Pre-operating system management applications

You can manage basic settings and features of a system without booting to the operating system by using the system firmware.

Topics:

- [Options to manage the pre-operating system applications](#)
- [System Setup](#)
- [Dell Lifecycle Controller](#)
- [Boot Manager](#)
- [PXE boot](#)

Options to manage the pre-operating system applications

Your system has the following options to manage the pre-operating system applications:

- System Setup
- Dell Lifecycle Controller
- Boot Manager
- Preboot Execution Environment (PXE)

System Setup

By using the **System Setup** screen, you can configure the BIOS settings, iDRAC settings, and device settings of your system.

i **NOTE: Help text for the selected field is displayed in the graphical browser by default. To view the help text in the text browser, press F1.**

You can access system setup by one of the following:

- Standard graphical browser—The browser is enabled by default.
- Text browser—The browser is enabled by using Console Redirection.

Viewing System Setup

To view the **System Setup** screen, perform the following steps:

Steps

1. Power on or restart your system.
2. Press F2 immediately after you see the following message:

```
F2 = System Setup
```

i **NOTE: If your operating system begins to load before you press F2, wait for the system to finish booting, and then restart your system and try again.**

System Setup details

The **System Setup Main Menu** screen details are explained as follows:

Option	Description
System BIOS	Enables you to configure BIOS settings.
iDRAC Settings	Enables you to configure the iDRAC settings. The iDRAC settings utility is an interface to set up and configure the iDRAC parameters by using UEFI (Unified Extensible Firmware Interface). You can enable or disable various iDRAC parameters by using the iDRAC settings utility. For more information about this utility, see <i>Integrated Dell Remote Access Controller User's Guide</i> at www.dell.com/xcseriesmanuals .
Device Settings	Enables you to configure device settings.

System BIOS

You can use the **System BIOS** screen to edit specific functions such as boot order, system password, and setup password, set the SATA and PCIe NVMe RAID mode, and enable or disable USB ports.

Viewing System BIOS

To view the **System BIOS** screen, perform the following steps:

Steps

1. Power on or restart your system.
2. Press F2 immediately after you see the following message:

```
F2 = System Setup
```

NOTE: If the operating system begins to load before you press F2, wait for the system to finish booting, and then restart the system and try again.

3. On the **System Setup Main Menu** screen, click **System BIOS**.

System BIOS Settings details

About this task

The **System BIOS Settings** screen details are explained as follows:

Option	Description
System Information	Provides information about the system such as the system model name, BIOS version, and Service Tag.
Memory Settings	Provides information and options related to the installed memory.
Processor Settings	Provides information and options related to the processor such as speed and cache size.
SATA Settings	Provides options to enable or disable the integrated SATA controller and ports.
Boot Settings	Provides options to specify the Boot mode (BIOS or UEFI). Enables you to modify UEFI and BIOS boot settings.
Network Settings	Provides options to manage the UEFI network settings and boot protocols. Legacy network settings are managed from the Device Settings menu.
Integrated Devices	Provides options to manage integrated device controllers and ports, specifies related features and options.
Serial Communication	Provides options to manage the serial ports, their related features and options.
System Profile Settings	Provides options to change the processor power management settings, and memory frequency.
System Security	Provides options to configure the system security settings, such as system password, setup password, Trusted Platform Module (TPM) security, and UEFI secure boot. It also manages the power button on the system.

Option	Description
Redundant OS Control	Sets the redundant OS information for redundant OS control.
Miscellaneous Settings	Provides options to change the system date and time.

System Information

You can use the **System Information** screen to view system properties such as Service Tag, system model name, and BIOS version.

Viewing System Information

To view the **System Information** screen, perform the following steps:

Steps

1. Power on or restart your system.
2. Press F2 immediately after you see the following message:

```
F2 = System Setup
```

NOTE: If your operating system begins to load before you press F2, wait for the system to finish booting, and then restart your system and try again.

3. On the **System Setup Main Menu** screen, click **System BIOS**.
4. On the **System BIOS** screen, click **System Information**.

System Information details

About this task

The **System Information** screen details are explained as follows:

Option	Description
System Model Name	Specifies the system model name.
System BIOS Version	Specifies the BIOS version installed on the system.
System Management Engine Version	Specifies the current version of the Management Engine firmware.
System Service Tag	Specifies the system Service Tag.
System Manufacturer	Specifies the name of the system manufacturer.
System Manufacturer Contact Information	Specifies the contact information of the system manufacturer.
System CPLD Version	Specifies the current version of the system complex programmable logic device (CPLD) firmware.
Secondary System CPLD Version	Specifies the current version of the system complex programmable logic device (CPLD) firmware.
UEFI Compliance Version	Specifies the UEFI compliance level of the system firmware.

Memory Settings

You can use the **Memory Settings** screen to view all the memory settings and enable or disable specific memory functions, such as system memory testing and node interleaving.

Viewing Memory Settings

To view the **Memory Settings** screen, perform the following steps:

Steps

1. Power on or restart your system.
2. Press F2 immediately after you see the following message:

```
F2 = System Setup
```

NOTE: If the operating system begins to load before you press F2, wait for the system to finish booting, and then restart the system and try again.

3. On the **System Setup Main Menu** screen, click **System BIOS**.
4. On the **System BIOS** screen, click **Memory Settings**.

Memory Settings details

About this task

The **Memory Settings** screen details are explained as follows:

Option	Description
System Memory Size	Specifies the memory size in the system.
System Memory Type	Specifies the type of memory installed in the system.
System Memory Speed	Specifies the system memory speed.
System Memory Voltage	Specifies the system memory voltage.
Video Memory	Specifies the amount of video memory.
System Memory Testing	Specifies whether the system memory tests are run during system boot. Options are Enabled and Disabled . This option is set to Disabled by default.
Current State of Memory Operating Mode	Specifies the current state of the memory operating mode.
Node Interleaving	Specifies if Non-Uniform Memory Architecture (NUMA) is supported. If this field is set to Enabled , memory interleaving is supported if a symmetric memory configuration is installed. If this field is set to Disabled , the system supports NUMA (asymmetric) memory configurations. This option is set to Disabled by default.
ADDDC Setting	Enables or disables ADDDC Setting feature. When Adaptive Double DRAM Device Correction (ADDDC) is enabled, failing DRAM's are dynamically mapped out. When set to Enabled it can have some impact to system performance under certain workloads. This feature is applicable for x4 DIMMs only. This option is set to Enabled by default.
Opportunistic Self-Refresh	Enables or disables opportunistic self-refresh feature. This option is set to Disabled by default.

Processor Settings

You can use the **Processor Settings** screen to view the processor settings and perform specific functions such as enabling virtualization technology, hardware prefetcher, logical processor idling.

Viewing Processor Settings

To view the **Processor Settings** screen, perform the following steps:

Steps

1. Power on or restart your system.
2. Press F2 immediately after you see the following message:

```
F2 = System Setup
```

NOTE: If your operating system begins to load before you press F2, wait for the system to finish booting, and then restart your system and try again.

3. On the **System Setup Main Menu** screen, click **System BIOS**.
4. On the **System BIOS** screen, click **Processor Settings**.

Processor Settings details

About this task

The **Processor Settings** screen details are explained as follows:

Option	Description
Logical Processor	Enables or disables the logical processors and displays the number of logical processors. If this option is set to Enabled , the BIOS displays all the logical processors. If this option is set to Disabled , the BIOS displays only one logical processor per core. This option is set to Enabled by default.
Virtualization Technology	Enables or disables the virtualization technology for the processor. This option is set to Enabled by default.
Adjacent Cache Line Prefetch	Optimizes the system for applications that need high utilization of sequential memory access. This option is set to Enabled by default. You can disable this option for applications that need high utilization of random memory access.
Hardware Prefetcher	Enables or disables the hardware prefetcher. This option is set to Enabled by default.
Software Prefetcher	Enables or disables the software prefetcher. This option is set to Enabled by default.
DCU Streamer Prefetcher	Enables or disables the Data Cache Unit (DCU) streamer prefetcher. This option is set to Enabled by default.
DCU IP Prefetcher	Enables or disables the Data Cache Unit (DCU) IP prefetcher. This option is set to Enabled by default.
Sub NUMA Cluster	Enables or disables the Sub NUMA Cluster. This option is set to Disabled by default.
UPI Prefetch	Enables you to get the memory read started early on DDR bus. The Ultra Path Interconnect (UPI) Rx path will spawn the speculative memory read to Integrated Memory Controller (iMC) directly. This option is set to Enabled by default.
Logical Processor Idling	Enables you to improve the energy efficiency of a system. It uses the operating system core parking algorithm and parks some of the logical processors in the system which in turn allows the corresponding processor cores to transition into a lower power idle state. This option can only be enabled if the operating system supports it. It is set to Disabled by default.
Configurable TDP	Enables you to configure the TDP level. The available options are Nominal , Level 1 , and Level 2 . This option is set to Nominal by default. NOTE: This option is only available on certain stock keeping units (SKUs) of the processors.

Option	Description
SST-Performance Profile	Enables you to reconfigure the processor using Speed Select Technology.
x2APIC Mode	Enables or disables the x2APIC mode. This option is set to Disabled by default.
Number of Cores per Processor	Controls the number of enabled cores in each processor. This option is set to All by default.
Processor Core Speed	Specifies the maximum core frequency of the processor.
Processor n	 NOTE: Depending on the number of processors, there might be up to n processors listed.

The following settings are displayed for each processor installed in the system:

Option	Description
Family-Model-Stepping	Specifies the family, model, and stepping of the processor as defined by Intel.
Brand	Specifies the brand name.
Level 2 Cache	Specifies the total L2 cache.
Level 3 Cache	Specifies the total L3 cache.
Number of Cores	Specifies the number of cores per processor.
Maximum Memory Capacity	Specifies the maximum memory capacity per processor.
Microcode	Specifies the microcode.

SATA Settings

 **NOTE: XC series does not support SATA settings.**

You can use the **SATA Settings** screen to view the settings of SATA devices and enable SATA and PCIe NVMe RAID mode on your system.

Viewing SATA Settings

To view the **SATA Settings** screen, perform the following steps:

Steps

1. Power on or restart your system.
2. Press F2 immediately after you see the following message:

```
F2 = System Setup
```

 **NOTE: If your operating system begins to load before you press F2, wait for the system to finish booting, and then restart your system and try again.**

3. On the **System Setup Main Menu** screen, click **System BIOS**.
4. On the **System BIOS** screen, click **SATA Settings**.

SATA Settings details

About this task

The **SATA Settings** screen details are explained as follows:

Option	Description
Embedded SATA	Enables the embedded SATA option to be set to AHCI Mode , or RAID Mode . This option is set to AHCI Mode by default.
Security Freeze Lock	Enables you to send Security Freeze Lock command to the embedded SATA drives during POST. This option is applicable only for AHCI mode. This option is set to Enabled by default.
Write Cache	Enables or disables the command for the embedded SATA drives during POST. This option is set to Disabled by default.
Port n	Enables you to set the drive type of the selected device. For AHCI Mode or RAID Mode , BIOS support is always enabled.
Option	Description
Model	Specifies the drive model of the selected device.
Drive Type	Specifies the type of drive attached to the SATA port.
Capacity	Specifies the total capacity of the drive. This field is undefined for removable media devices such as optical drives.

Boot Settings

You can use the **Boot Settings** screen to set the boot mode to either **BIOS** or **UEFI**. It also enables you to specify the boot order.

- **UEFI:** The Unified Extensible Firmware Interface (UEFI) is a new interface between operating systems and platform firmware. The interface consists of data tables with platform related information, boot and runtime service calls that are available to the operating system and its loader. The following benefits are available when the **Boot Mode** is set to **UEFI**:
 - Support for drive partitions larger than 2 TB.
 - Enhanced security (e.g., UEFI Secure Boot).
 - Faster boot time.
- **BIOS:** The **BIOS Boot Mode** is the legacy boot mode. It is maintained for backward compatibility.

Viewing Boot Settings

To view the **Boot Settings** screen, perform the following steps:

Steps

1. Power on or restart your system.
2. Press F2 immediately after you see the following message:

```
F2 = System Setup
```

 **NOTE:** If your operating system begins to load before you press F2, wait for the system to finish booting, and then restart your system and try again.



3. On the **System Setup Main Menu** screen, click **System BIOS**.
4. On the **System BIOS** screen, click **Boot Settings**.

Boot Settings details

About this task

The **Boot Settings** screen details are explained as follows:

Option	Description
Boot Mode	Enables you to set the boot mode of the system.  CAUTION: Switching the boot mode may prevent the system from booting if the operating system is not installed in the same boot mode.

Option	Description
	<p>If the operating system supports UEFI, you can set this option to UEFI. Setting this field to BIOS enables compatibility with non-UEFI operating systems. This option is set to UEFI by default.</p> <p> NOTE: Setting this field to UEFI disables the BIOS Boot Settings menu.</p>
Boot Sequence Retry	Enables or disables the Boot Sequence Retry feature. If this option is set to Enabled and the system fails to boot, the system re-attempts the boot sequence after 30 seconds. This option is set to Enabled by default.
Hard-Disk Failover	Specifies the drive that is booted in the event of a drive failure. The devices are selected in the Hard-Disk Drive Sequence on the Boot Option Setting menu. When this option is set to Disabled , only the first drive in the list is attempted to boot. When this option is set to Enabled , all drives are attempted to boot in the order selected in the Hard-Disk Drive Sequence . This option is not enabled for UEFI Boot Mode . This option is set to Disabled by default.
Generic USB Boot	Enables or disables the USB boot option. This option is set to Disabled by default.
Hard-disk Drive Placeholder	Enables or disables the Hard-disk drive placeholder option. This option is set to Disabled by default.
BIOS Boot Settings	Enables or disables BIOS boot options.  NOTE: This option is enabled only if the boot mode is BIOS.
UEFI Boot Settings	Enables or disables UEFI Boot options. The Boot options include IPv4 PXE and IPv6 PXE . This option is set to IPv4 by default.  NOTE: This option is enabled only if the boot mode is UEFI.
UEFI Boot Sequence	Enables you to change the boot device order.
Boot Options Enable/Disable	Enables you to select the enabled or disabled boot devices.

Choosing system boot mode

System Setup enables you to specify one of the following boot modes for installing your operating system:

- BIOS boot mode (the default) is the standard BIOS-level boot interface.
- UEFI boot mode (the default), is an enhanced 64-bit boot interface.

If you have configured your system to boot to UEFI mode, it replaces the system BIOS.

1. From the **System Setup Main Menu**, click **Boot Settings**, and select **Boot Mode**.
2. Select the UEFI boot mode you want the system to boot into.

 **CAUTION: Switching the boot mode may prevent the system from booting if the operating system is not installed in the same boot mode.**

3. After the system boots in the specified boot mode, proceed to install your operating system from that mode.

 **NOTE: Operating systems must be UEFI-compatible to be installed from the UEFI boot mode. DOS and 32-bit operating systems do not support UEFI and can only be installed from the BIOS boot mode.**

 **NOTE: For the latest information about supported operating systems, go to www.dell.com/ossupport.**

Changing boot order

About this task

You may have to change the boot order if you want to boot from a USB key or an optical drive. The following instructions may vary if you have selected **BIOS** for **Boot Mode**.

 **NOTE: Ensure that you do not alter the boot order.**

Steps

1. On the **System Setup Main Menu** screen, click **System BIOS > Boot Settings > UEFI/BIOS Boot Settings > UEFI/BIOS Boot Sequence**.
2. Click **Exit**, and then click **Yes** to save the settings on exit.

Network Settings

You can use the **Network Settings** screen to modify UEFI PXE, iSCSI, and HTTP boot settings. The network settings option is available only in the UEFI mode.

NOTE: BIOS does not control network settings in the BIOS mode. For the BIOS boot mode, the optional Boot ROM of the network controllers handles the network settings.

Viewing Network Settings

To view the **Network Settings** screen, perform the following steps:

Steps

1. Power on or restart your system.
2. Press F2 immediately after you see the following message:

```
F2 = System Setup
```

NOTE: If your operating system begins to load before you press F2, wait for the system to finish booting, and then restart your system and try again.

3. On the **System Setup Main Menu** screen, click **System BIOS**.
4. On the **System BIOS** screen, click **Network Settings**.

Network Settings screen details

The **Network Settings** screen details are explained as follows:

About this task

Option	Description				
UEFI PXE Settings	<table><thead><tr><th>Options</th><th>Description</th></tr></thead><tbody><tr><td>PXE Device n (n = 1 to 4)</td><td>Enables or disables the device. When enabled, a UEFI PXE boot option is created for the device.</td></tr></tbody></table>	Options	Description	PXE Device n (n = 1 to 4)	Enables or disables the device. When enabled, a UEFI PXE boot option is created for the device.
Options	Description				
PXE Device n (n = 1 to 4)	Enables or disables the device. When enabled, a UEFI PXE boot option is created for the device.				
PXE Device n Settings (n = 1 to 4)	Enables you to control the configuration of the PXE device.				
UEFI HTTP Settings	<table><thead><tr><th>Options</th><th>Description</th></tr></thead><tbody><tr><td>HTTP Device (n = 1 to 4)</td><td>Enables or disables the device. When enabled, a UEFI HTTP boot option is created for the device.</td></tr></tbody></table>	Options	Description	HTTP Device (n = 1 to 4)	Enables or disables the device. When enabled, a UEFI HTTP boot option is created for the device.
Options	Description				
HTTP Device (n = 1 to 4)	Enables or disables the device. When enabled, a UEFI HTTP boot option is created for the device.				
HTTP Device n Settings (n = 1 to 4)	Enables you to control the configuration of the HTTP device.				

Integrated Devices

You can use the **Integrated Devices** screen to view and configure the settings of all integrated devices including the video controller, integrated RAID controller, and the USB ports.

Viewing Integrated Devices

To view the **Integrated Devices** screen, perform the following steps:

Steps

1. Power on or restart your system.
2. Press F2 immediately after you see the following message:

```
F2 = System Setup
```

NOTE: If your operating system begins to load before you press F2, wait for the system to finish booting, and then restart your system and try again.

3. On the **System Setup Main Menu** screen, click **System BIOS**.
4. On the **System BIOS** screen, click **Integrated Devices**.

Integrated Devices details

About this task

The **Integrated Devices** screen details are explained as follows:

Option	Description
iDRAC Direct USB Port	The iDRAC Direct USB port is managed by iDRAC exclusively with no host visibility. This option is set to ON or OFF . When set to OFF , iDRAC does not detect any USB devices installed in this managed port. This option is set to On by default.
I/OAT DMA Engine	Enables or disables the I/O Acceleration Technology (I/OAT) option. I/OAT is a set of DMA features designed to accelerate network traffic and lower CPU utilization. Enable only if the hardware and software support the feature. This option is set to Disabled by default.
Embedded Video Controller	Enables or disables the use of Embedded Video Controller as the primary display. When set to Enabled , the Embedded Video Controller is used as the primary display even if add-in graphic cards are installed. When set to Disabled , an add-in graphics card is used as the primary display. BIOS will output displays to both the primary add-in video and the embedded video during POST and pre-boot environment. The embedded video is disabled before the operating system boots. This option is set to Enabled by default. NOTE: When there are multiple add-in graphic cards installed in the system, the first card discovered during PCI enumeration is selected as the primary video. You might have to re-arrange the cards in the slots in order to control which card is the primary video.
Current State of Embedded Video Controller	Displays the current state of the embedded video controller. The Current State of Embedded Video Controller option is a read-only field. If the Embedded Video Controller is the only display capability in the system (that is, no add-in graphics card is installed), then the Embedded Video Controller is automatically used as the primary display even if the Embedded Video Controller setting is set to Disabled .
SR-IOV Global Enable	Enables or disables the BIOS configuration of Single Root I/O Virtualization (SR-IOV) devices. This option is set to Disabled by default.
OS Watchdog Timer	If your system stops responding, this watchdog timer aids in the recovery of your operating system. When this option is set to Enabled , the operating system initializes the timer. When this option is set to Disabled (the default), the timer does not have any effect on the system.
Empty Slot Unhide	Enables or disables the root ports of all the empty slots that are accessible to the BIOS and OS. This option is set to Enabled by default.
Memory Mapped I/O above 4 GB	Enables or disables the support for the PCIe devices that need large amounts of memory. Enable this option only for 64-bit operating systems. This option is set to Enabled by default.

Serial Communication

You can use the **Serial Communication** screen to view the properties of the serial communication port.

Viewing Serial Communication

To view the **Serial Communication** screen, perform the following steps:

Steps

1. Power on or restart your system.
2. Press F2 immediately after you see the following message:

```
F2 = System Setup
```

NOTE: If your operating system begins to load before you press F2, wait for the system to finish booting, and then restart your system and try again.

3. On the **System Setup Main Menu** screen, click **System BIOS**.
4. On the **System BIOS** screen, click **Serial Communication**.

Serial Communication details

About this task

The **Serial Communication** screen details are explained as follows:

Option	Description
Serial Port Address	Enables you to set the port address for serial device. This field sets the serial port address to either COM1 or COM2 (COM1=0x3F8, COM2=0x2F8). NOTE: You can use only Serial Device 2 for the Serial Over LAN (SOL) feature. To use console redirection by SOL, configure the same port address for console redirection and the serial device. NOTE: Every time the system boots, the BIOS syncs the serial MUX setting saved in iDRAC. The serial MUX setting can independently be changed in iDRAC. Loading the BIOS default settings from within the BIOS setup utility may not always revert the serial MUX setting to the default setting of Serial Device 1.
Failsafe Baud Rate	Specifies the failsafe baud rate for console redirection. The BIOS attempts to determine the baud rate automatically. This failsafe baud rate is used only if the attempt fails, and the value must not be changed. This option is set to 115200 by default.
Remote Terminal Type	Enables you to set the remote console terminal type. This option is set to VT100/VT220 by default.
Redirection After Boot	Enables or disables the BIOS console redirection when the operating system is loaded. This option is set to Enabled by default.

System Profile Settings

You can use the **System Profile Settings** screen to enable specific system performance settings such as power management.

Viewing System Profile Settings

To view the **System Profile Settings** screen, perform the following steps:

Steps

1. Power on or restart your system.
2. Press F2 immediately after you see the following message:

```
F2 = System Setup
```

NOTE: If your operating system begins to load before you press F2, wait for the system to finish booting, and then restart your system and try again.

3. On the **System Setup Main Menu** screen, click **System BIOS**.
4. On the **System BIOS** screen, click **System Profile Settings**.

System Profile Settings details

About this task

The **System Profile Settings** screen details are explained as follows:

Option	Description
System Profile	Sets the system profile. If you set the System Profile option to a mode other than Custom , the BIOS automatically sets the rest of the options. You can only change the rest of the options if the mode is set to Custom . This option is set to Performance Per Watt Optimized (DAPC) by default. DAPC is Dell Active Power Controller. NOTE: All the parameters on the system profile setting screen are available only when the System Profile option is set to Custom.
CPU Power Management	Sets the CPU power management. This option is set to System DBPM (DAPC) by default. DBPM is Demand-Based Power Management.
Memory Frequency	Sets the speed of the system memory. You can select Maximum Performance , Maximum Reliability , or a specific speed. This option is set to Maximum Performance by default.
Turbo Boost	Enables or disables the processor to operate in the turbo boost mode. This option is set to Enabled by default.
C1E	Enables or disables the processor to switch to a minimum performance state when it is idle. This option is set to Enabled by default.
Write Data CRC	Enables or disables the Write Data CRC. This option is set to Disabled by default.
Memory Patrol Scrub	Sets the memory patrol scrub frequency. This option is set to Standard by default.
Memory Refresh Rate	Sets the memory refresh rate to either 1x or 2x. This option is set to 1x by default.
Uncore Frequency	Enables you to select the Processor Uncore Frequency option. Dynamic mode enables the processor to optimize power resources across cores and uncores during runtime. The optimization of the uncore frequency to either save power or optimize performance is influenced by the setting of the Energy Efficiency Policy option.
Energy Efficient Policy	Enables you to select the Energy Efficient Policy option. The CPU uses the setting to manipulate the internal behavior of the processor and determines whether to target higher performance or better power savings. This option is set to Balanced Performance by default.
Number of Turbo Boost Enabled Cores for Processor 1	NOTE: If there are two processors installed in the system, you will see an entry for Number of Turbo Boost Enabled Cores for Processor 2 . Controls the number of turbo boost enabled cores for Processor 1. The maximum number of cores is enabled by default.
Monitor/Mwait	Enables the Monitor/Mwait instructions in the processor. This option is set to Enabled for all system profiles, except Custom by default. NOTE: This option can be disabled only if the C States option in the Custom mode is set to disabled. NOTE: When C States is set to Enabled in the Custom mode, changing the Monitor/Mwait setting does not impact the system power or performance.
CPU Interconnect Bus Link Power Management	Enables or disables the CPU Interconnect Bus Link Power Management. This option is set to Enabled by default.

Option	Description
PCI ASPM L1 Link Power Management	Enables or disables the PCI ASPM L1 Link Power Management. This option is set to Enabled by default.

System Security

You can use the **System Security** screen to perform specific functions such as setting the system password, setup password and disabling the power button.

Viewing System Security

To view the **System Security** screen, perform the following steps:

Steps

1. Power on or restart your system.
2. Press F2 immediately after you see the following message:

```
F2 = System Setup
```

NOTE: If your operating system begins to load before you press F2, wait for the system to finish booting, and then restart your system and try again.

3. On the **System Setup Main Menu** screen, click **System BIOS**.
4. On the **System BIOS** screen, click **System Security**.

System Security Settings details

About this task

The **System Security Settings** screen details are explained as follows:

Option	Description
CPU AES-NI	Improves the speed of applications by performing encryption and decryption by using the Advanced Encryption Standard Instruction Set (AES-NI). This option is set to Enabled by default.
Setup Password	Enables you to set the system setup password. This option is read-only if the password jumper is not installed in the system.
Password Status	Enables you to lock the system password. This option is set to Unlocked by default.
TPM Security	<p>NOTE: The TPM menu is available only when the TPM module is installed.</p> <p>Enables you to control the reporting mode of the TPM. The TPM Security option is set to Off by default. You can only modify the TPM Status, TPM Activation, and the Intel TXT fields if the TPM Status field is set to either On with Pre-boot Measurements or On without Pre-boot Measurements.</p>
Intel(R) TXT	Enables you to set the Intel Trusted Execution Technology (TXT) option. To enable the Intel TXT option, virtualization technology and TPM Security must be enabled with Pre-boot measurements. This option is set to Off by default.
Power Button	Enables you to set the power button on the front of the system. This option is set to Enabled by default.
AC Power Recovery	Sets how the system behaves after AC power is restored to the system. This option is set to Last by default.
UEFI Variable Access	Provides varying degrees of securing UEFI variables. When set to Standard (the default), UEFI variables are accessible in the operating system per the UEFI specification. When set to Controlled , selected UEFI variables are protected in the environment, and new UEFI boot entries are forced to be at the end of the current boot order.
Secure Boot	Enables Secure Boot, where the BIOS authenticates each pre-boot image by using the certificates in the Secure Boot Policy. Secure Boot is set to Disabled by default.

Option	Description								
Secure Boot Policy	When Secure Boot policy is set to Standard , the BIOS uses the system manufacturer key and certificates to authenticate pre-boot images. When Secure Boot policy is set to Custom , the BIOS uses the user-defined key and certificates. Secure Boot policy is set to Standard by default.								
Secure Boot Mode	Enables you to configure how the BIOS uses the Secure Boot Policy Objects (PK, KEK, db, dbx). If the current mode is set to Deployed Mode , the available options are User Mode and Deployed Mode . If the current mode is set to User Mode , the available options are User Mode , Audit Mode , and Deployed Mode .								
	<table border="1"> <thead> <tr> <th>Options</th> <th>Description</th> </tr> </thead> <tbody> <tr> <td>User Mode</td> <td>In User Mode, PK must be installed, and BIOS performs signature verification on programmatic attempts to update policy objects. BIOS allows unauthenticated programmatic transitions between modes.</td> </tr> <tr> <td>Audit Mode</td> <td>In Audit mode, PK is not present. BIOS does not authenticate programmatic updates to the policy objects, and transitions between modes. Audit Mode is useful for programmatically determining a working set of policy objects. BIOS performs signature verification on pre-boot images and logs the results in the image Execution Information Table, but approves the images whether they pass or fail verification.</td> </tr> <tr> <td>Deployed Mode</td> <td>Deployed Mode is the most secure mode. In Deployed Mode, PK must be installed and the BIOS performs signature verification on programmatic attempts to update policy objects. Deployed Mode restricts the programmatic mode transitions.</td> </tr> </tbody> </table>	Options	Description	User Mode	In User Mode , PK must be installed, and BIOS performs signature verification on programmatic attempts to update policy objects. BIOS allows unauthenticated programmatic transitions between modes.	Audit Mode	In Audit mode , PK is not present. BIOS does not authenticate programmatic updates to the policy objects, and transitions between modes. Audit Mode is useful for programmatically determining a working set of policy objects. BIOS performs signature verification on pre-boot images and logs the results in the image Execution Information Table, but approves the images whether they pass or fail verification.	Deployed Mode	Deployed Mode is the most secure mode. In Deployed Mode , PK must be installed and the BIOS performs signature verification on programmatic attempts to update policy objects. Deployed Mode restricts the programmatic mode transitions.
Options	Description								
User Mode	In User Mode , PK must be installed, and BIOS performs signature verification on programmatic attempts to update policy objects. BIOS allows unauthenticated programmatic transitions between modes.								
Audit Mode	In Audit mode , PK is not present. BIOS does not authenticate programmatic updates to the policy objects, and transitions between modes. Audit Mode is useful for programmatically determining a working set of policy objects. BIOS performs signature verification on pre-boot images and logs the results in the image Execution Information Table, but approves the images whether they pass or fail verification.								
Deployed Mode	Deployed Mode is the most secure mode. In Deployed Mode , PK must be installed and the BIOS performs signature verification on programmatic attempts to update policy objects. Deployed Mode restricts the programmatic mode transitions.								
Secure Boot Policy Summary	Specifies the list of certificates and hashes that secure boot uses to authenticate images.								
Secure Boot Custom Policy Settings	Configures the Secure Boot Custom Policy. To enable this option, set the Secure Boot Policy to Custom .								

Creating a system and setup password

Prerequisites

Ensure that the password jumper is enabled. The password jumper enables or disables the system password and setup password features. For more information, see the System board jumper settings section.

NOTE: If the password jumper setting is disabled, the existing system password and setup password are deleted and you need not provide the system password to boot the system.

Steps

- To enter System Setup, press F2 immediately after turning on or rebooting your system.
- On the **System Setup Main Menu** screen, click **System BIOS > System Security**.
- On the **System Security** screen, verify that **Password Status** is set to **Unlocked**.
- In the **System Password** field, type your system password, and press Enter or Tab.
Use the following guidelines to assign the system password:
 - A password can have up to 32 characters.
 - The password can contain the numbers 0 through 9.
 - Only the following special characters are allowed: space, ("), (+), (.), (-), (.), (/), (:), (I), (\), (J), (').
A message prompts you to reenter the system password.
- Reenter the system password, and click **OK**.
- In the **Setup Password** field, type your setup password and press Enter or Tab.
A message prompts you to reenter the setup password.

7. Reenter the setup password, and click **OK**.
8. Press Esc to return to the system BIOS screen. Press Esc again.
A message prompts you to save the changes.

 **NOTE: Password protection does not take effect until the system reboots.**

Using your system password to secure the system

About this task

If you have assigned a setup password, the system accepts your setup password as an alternate system password.

Steps

1. Power on or reboot your system.
2. Type the system password and press Enter.

Next steps

When **Password Status** is set to **Locked**, type the system password and press Enter when prompted at reboot.



 **NOTE: If an incorrect system password is typed, the system displays a message and prompts you to reenter your password. You have three attempts to type the correct password. After the third unsuccessful attempt, the system displays an error message that the system has stopped functioning and must be turned off. Even after you turn off and restart the system, the error message is displayed until the correct password is entered.**

Deleting or changing system and setup password

Prerequisites

 **NOTE: You cannot delete or change an existing system or setup password if the Password Status is set to Locked.**

Steps

1. To enter System Setup, press F2 immediately after turning on or restarting your system.
2. On the **System Setup Main Menu** screen, click **System BIOS > System Security**.
3. On the **System Security** screen, ensure that **Password Status** is set to **Unlocked**.
4. In the **System Password** field, change or delete the existing system password, and then press Enter or Tab.
5. In the **Setup Password** field, alter or delete the existing setup password, and then press Enter or Tab.
 **NOTE: If you change the system password or setup password, a message prompts you to reenter the new password. If you delete the system password or setup password, a message prompts you to confirm the deletion.**
6. Press Esc to return to the **System BIOS** screen. Press Esc again, and a message prompts you to save the changes.
7. Select **Setup Password**, change, or delete the existing setup password and press Enter or Tab.
 **NOTE: If you change the system password or setup password, a message prompts you to reenter the new password. If you delete the system password or setup password, a message prompts you to confirm the deletion.**

Operating with setup password enabled

If **Setup Password** is set to **Enabled**, type the correct setup password before modifying the system setup options.

If you do not type the correct password in three attempts, the system displays the following message:

```
Invalid Password! Number of unsuccessful password attempts: <x> System Halted! Must power down.
```

```
Password Invalid. Number of unsuccessful password attempts: <x> Maximum number of password attempts exceeded. System halted.
```

Even after you restart the system, the error message is displayed until the correct password is typed. The following options are exceptions:

- If **System Password** is not set to **Enabled** and is not locked through the **Password Status** option, you can assign a system password. For more information, see the [System Security Settings details](#) section.
- You cannot disable or change an existing system password.

i **NOTE:** You can use the password status option with the setup password option to protect the system password from unauthorized changes.

Redundant OS Control

In the **Redundant OS Control** screen you can set the redundant OS information. This enables you to set up a physical recovery disk on the system.

Viewing Redundant OS Control

To view the **Redundant OS Control** screen, perform the following steps:

Steps

1. Power on or restart your system.
2. Press F2 immediately after you see the following message:

```
F2 = System Setup
```

i **NOTE:** If your operating system begins to load before you press F2, wait for the system to finish booting, and then restart your system and try again.

3. On the **System Setup Main Menu** screen, click **System BIOS**.
4. On the **System BIOS** screen, click **Redundant OS Control**.

Redundant OS Control screen details

The **Redundant OS Control** screen details are explained as follows:

About this task

Option	Description
Redundant OS Location	<p>Enables you to select a backup disk from the following devices:</p> <ul style="list-style-type: none">· None· IDSDM· SATA Ports in AHCI mode· BOSS PCIe Cards (Internal M.2 Drives)· Internal USB <p>i NOTE: RAID configurations and NVMe cards not are included as BIOS does not have the ability to distinguish between individual drives in those configurations.</p>
Redundant OS State	<p>i NOTE: This option is disabled if Redundant OS Location is set to None.</p> <p>When set to Visible, the backup disk is visible to the boot list and OS. When set to Hidden, the backup disk is disabled and is not visible to the boot list and OS. This option is set to Visible by default.</p> <p>i NOTE: BIOS will disable the device in hardware, so it cannot be accessed by the OS.</p>
Redundant OS Boot	<p>i NOTE: This option is disabled if Redundant OS Location is set to None or if Redundant OS State is set to Hidden.</p> <p>When set to Enabled, BIOS boots to the device specified in Redundant OS Location. When set to Disabled, BIOS preserves the current boot list settings. This option is set to Disabled by default.</p>

Miscellaneous Settings

You can use the **Miscellaneous Settings** screen to perform specific functions such as updating the asset tag and changing the system date and time.

Viewing Miscellaneous Settings

To view the **Miscellaneous Settings** screen, perform the following steps:

Steps

1. Power on or restart your system.
2. Press F2 immediately after you see the following message:

```
F2 = System Setup
```

NOTE: If your operating system begins to load before you press F2, wait for the system to finish booting, and then restart your system and try again.

3. On the **System Setup Main Menu** screen, click **System BIOS**.
4. On the **System BIOS** screen, click **Miscellaneous Settings**.

Miscellaneous Settings details

About this task

The **Miscellaneous Settings** screen details are explained as follows:

Option	Description
System Time	Enables you to set the time on the system.
System Date	Enables you to set the date on the system.
Asset Tag	Specifies the asset tag and enables you to modify it for security and tracking purposes.
Keyboard NumLock	Enables you to set whether the system should boot with the NumLock enabled or disabled. This option is set to On by default. NOTE: This option does not apply to 84-key keyboards.
F1/F2 Prompt on Error	Enables or disables the F1/F2 prompt on error. This option is set to Enabled by default. The F1/F2 prompt also includes keyboard errors.
Load Legacy Video Option ROM	Enables you to determine whether the system BIOS loads the legacy video (INT 10H) option ROM from the video controller. Selecting Enabled in the operating system does not support UEFI video output standards. This field is available only for UEFI boot mode. You cannot set the option to Enabled if UEFI Secure Boot mode is enabled. This option is set to Disabled by default.
Dell Wyse P25/P45 BIOS Access	Enables or disables the Dell Wyse P25/P45 BIOS Access. This option is set to Enabled by default.

iDRAC Settings utility

The iDRAC settings utility is an interface to set up and configure the iDRAC parameters by using UEFI. You can enable or disable various iDRAC parameters by using the iDRAC settings utility.

NOTE: Accessing some of the features on the iDRAC settings utility needs the iDRAC Enterprise License upgrade.

For more information about using iDRAC, see *Dell Integrated Dell Remote Access Controller User's Guide* at www.dell.com/xcseriesmanuals.

Device Settings

Device Settings enables you to configure the below device parameters:

- Controller Configuration Utility
- Embedded NIC Port1-X Configuration
- NICs in slotX, Port1-X Configuration
- BOSS Card configuration

Dell Lifecycle Controller

Dell Lifecycle Controller (LC) provides advanced embedded systems management capabilities including system deployment, configuration, update, maintenance, and diagnosis. LC is delivered as part of the iDRAC out-of-band solution and Dell system embedded Unified Extensible Firmware Interface (UEFI) applications.

Embedded system management

The Dell Lifecycle Controller provides advanced embedded system management throughout the lifecycle of the system. The Dell Lifecycle Controller can be started during the boot sequence and can function independently of the operating system.

 **NOTE: Certain platform configurations may not support the full set of features provided by the Dell Lifecycle Controller.**

For more information about setting up the Dell Lifecycle Controller, configuring hardware and firmware, and deploying the operating system, see the Dell Lifecycle Controller documentation at www.dell.com/xcseriesmanuals.

Boot Manager

The **Boot Manager** screen enables you to select boot options and diagnostic utilities.

Viewing Boot Manager

About this task

To enter Boot Manager:

Steps

1. Power on, or restart your system.
2. Press F11 when you see the following message:

F11 = Boot Manager

If your operating system begins to load before you press F11, allow the system to complete the booting, and then restart your system and try again.

Boot Manager main menu

Menu item	Description
Continue Normal Boot	The system attempts to boot to devices starting with the first item in the boot order. If the boot attempt fails, the system continues with the next item in the boot order until the boot is successful or no more boot options are found.
One-shot Boot Menu	Enables you to access boot menu, where you can select a one-time boot device to boot from.
Launch System Setup	Enables you to access System Setup.
Launch Lifecycle Controller	Exits the Boot Manager and invokes the Dell Lifecycle Controller program.

Menu item	Description
System Utilities	Enables you to launch System Utilities menu such as System Diagnostics and UEFI shell.

One-shot UEFI boot menu

One-shot UEFI boot menu enables you to select a boot device to boot from.

System Utilities

System Utilities contains the following utilities that can be launched:

- Launch Diagnostics
- BIOS Update File Explorer
- Reboot System

PXE boot

 **NOTE: XC series does not support PXE boot.**

You can use the Preboot Execution Environment (PXE) option to boot and configure the networked systems, remotely.

To access the **PXE boot** option, boot the system and then press F12 during POST instead of using standard Boot Sequence from BIOS Setup. It does not pull any menu or allows managing of network devices.

Installing and removing system components

Installing and removing system components

The following sections contain the procedures for removing and replacing system components.

Safety instructions

⚠ WARNING: Do not attempt to lift the system by yourself to avoid potential injury. Do not apply uneven force to either end of the system to prevent the chassis from distorting or bending. Keep the system parallel to the ground when lifting and moving it.

⚠ WARNING: Opening or removing the system cover while the system is powered on may expose you to a risk of electric shock.

ℹ NOTE: This product is intended for restricted access locations, such as a dedicated equipment room or equipment closet, in accordance with the National Electrical Code, American National Standards Institute (ANSI), National Fire Protection Association (NFPA) 70.

Equipment Location - The equipment placed in the restricted access location that can be accessed only by the service personnel or users who have been instructed about the restrictions applied to the location. The location can be accessed using a tool or a key or any other means of security, and is controlled by the authority responsible for the location.

⚠ CAUTION: Do not operate the system without the cover for a duration exceeding five minutes. Operating the system without the system cover can result in component damage.

⚠ CAUTION: Many repairs may only be done by a certified service technician. You should only perform troubleshooting and simple repairs as authorized in your product documentation, or as directed by the online or telephone service and support team. Damage due to servicing that is not authorized by Dell is not covered by your warranty. Read and follow the safety instructions that are shipped with your product.

⚠ CAUTION: To ensure proper operation and cooling, all bays in the system and system fans must be always populated with a component or a blank.

ℹ NOTE: It is recommended that you always use an antistatic mat and antistatic strap while working on components inside the system.

⚠ CAUTION: Keep hands clear off the rotating fan blades of the high performance fans, as it may cause serious injury or cuts. Ensure system is powered off before servicing.

Before working inside your system

Prerequisites

Follow the safety guidelines listed in [Safety Instructions](#).

Steps

1. Power off the system and all attached peripherals.
2. Disconnect the system from the electrical outlet, and disconnect the peripherals.

After working inside your system

Prerequisites

Follow the safety guidelines listed in [Safety Instructions](#).

Steps

1. Reconnect the peripherals and connect the system to the electrical outlet.
2. Power on the attached peripherals and then power on the system.

Recommended tools

You need the following tools to perform the removal and installation procedures:

- Key to the bezel lock
The key is required only if your system includes a bezel.
- Phillips #1 screwdriver
- Phillips #2 screwdriver
- Torx #T15 screwdriver
- 5mm hex nut screwdriver
- Plastic scribe
- 1/4 inch flat blade screwdriver
- Wrist grounding strap connected to the ground
- ESD mat

You need the following tools to assemble the cables for a DC power supply unit:

- AMP 90871-1 hand-crimping tool or equivalent
- Tyco Electronics 58433-3 or equivalent
- Wire-stripper pliers to remove insulation from size 10 AWG solid or stranded, insulated copper wire

 **NOTE: Use alpha wire part number 3080 or equivalent (65/30 stranding).**

Front bezel

Removing the front bezel

Prerequisites

1. Follow the safety guidelines listed in [Safety Instructions](#).
2. Keep the bezel key handy.

Steps

1. Unlock the bezel.
2. Press the release button, and remove the left end of the bezel.
3. Unhook the right end of the bezel, and remove the bezel.

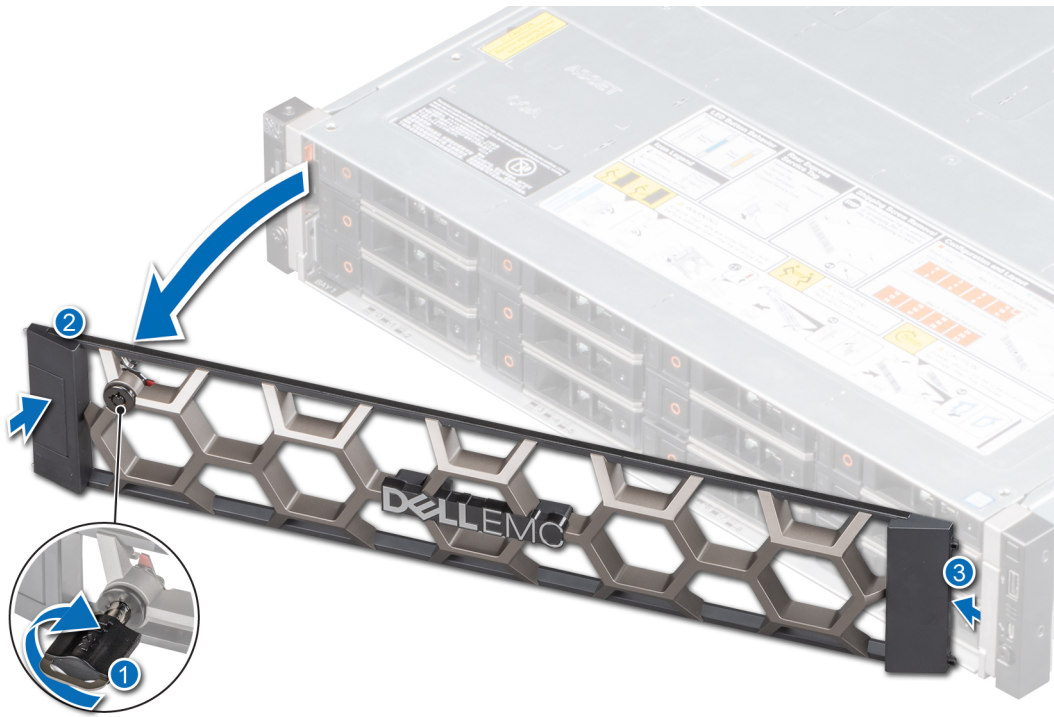

Figure 14. Removing the front bezel

Next steps

Replace the front bezel.

Installing the front bezel

Prerequisites

1. Follow the safety guidelines listed in [Safety Instructions](#).
2. Locate and remove the bezel key.

NOTE: The bezel key is part of the front bezel package.

Steps

1. Align and insert the tabs on the right end of the bezel into the slots on the system.

NOTE: Ensure that the drive bay is locked before installing the front bezel, for more information see [closing the drive bays](#) section.

2. Fit the left end of the bezel onto the system and press the bezel until you hear the release button click.
3. Lock the bezel.

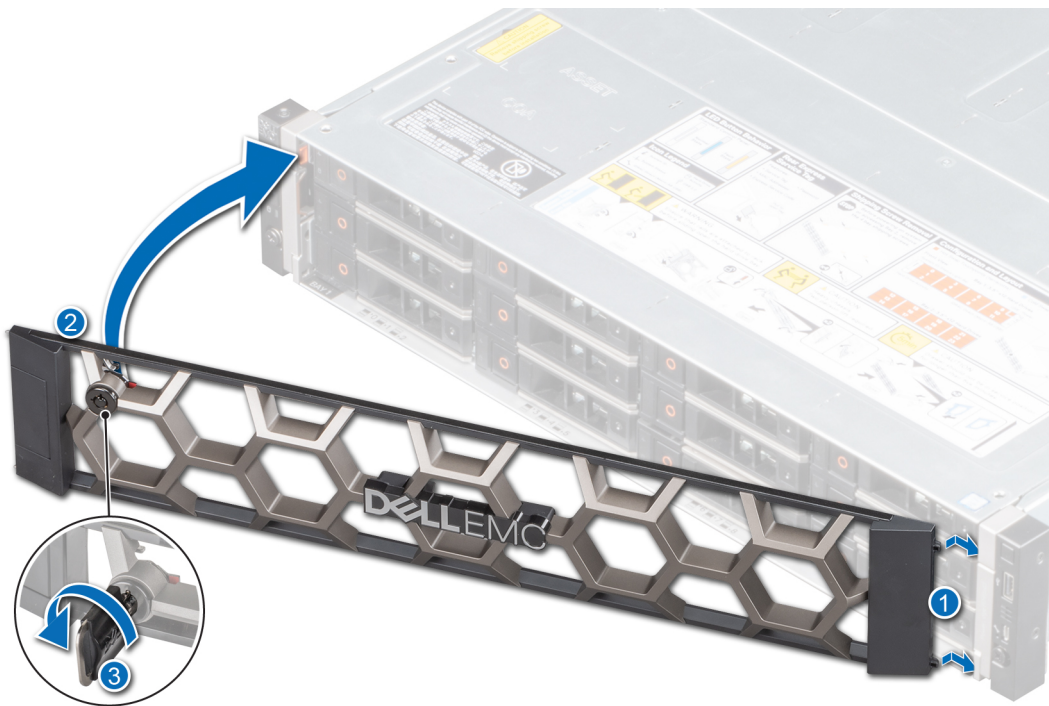

Figure 15. Installing the front bezel

System cover

Removing the system cover

Prerequisites

1. Follow the safety guidelines listed in [Safety Instructions](#).
2. Power off the system and all attached peripherals.
3. Disconnect the system from the electrical outlet, and disconnect the peripherals.
4. [Open the drive bays](#), remove **all drives**, and then [close the drive bays](#).
5. Remove the [power supply units](#).
6. Remove the system from the rack and place it on an ESD work bench. For more information, see the *Rail Installation Guide* available at www.dell.com/xcseriesmanuals.

Steps

1. Using a 1/4-inch flat head or Phillips #2 screwdriver, turn the lock counterclockwise to the unlock position.
2. Press the release tabs on the system cover, and slide the cover towards the rear of the system.
3. Lift the cover from the system.

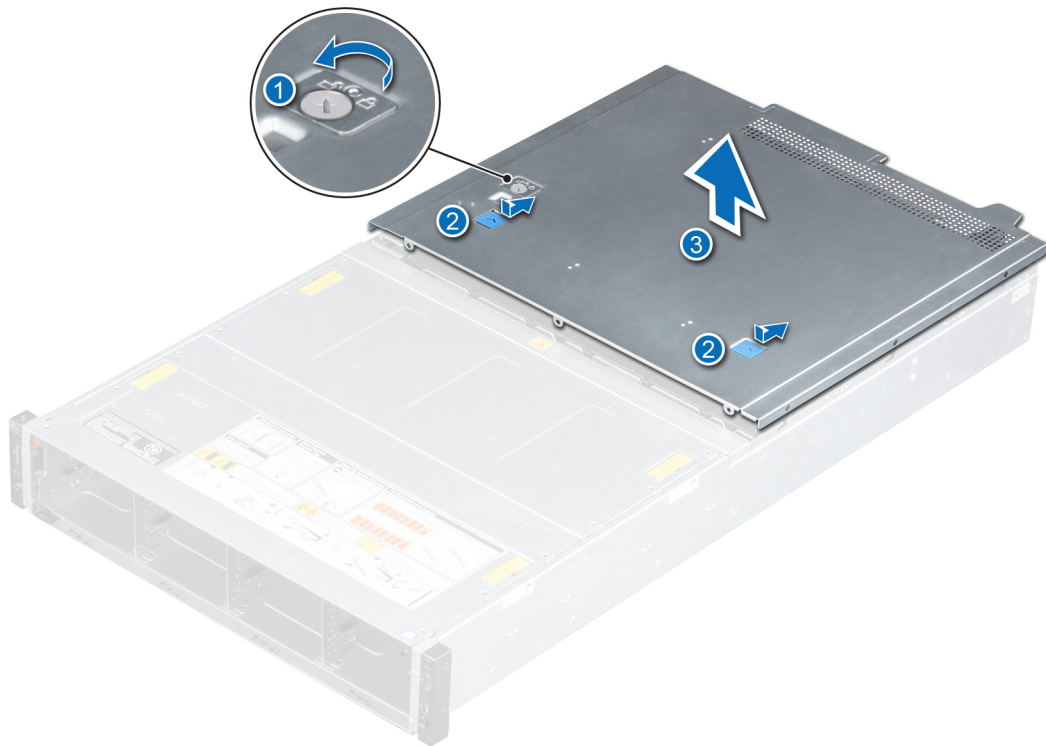

Figure 16. Removing the system cover

Installing the system cover

Prerequisites

1. Follow the safety guidelines listed in [Safety Instructions](#).
2. Power off the system and all attached peripherals.
3. Disconnect the system from the electrical outlet, and disconnect the peripherals.
4. Ensure that all internal cables are routed correctly and connected, and no tools or extra parts are left inside the system.
5. [Open the drive bays](#), remove [all drives](#), and then [close the drive bays](#).
6. Remove the [power supply units](#).
7. Remove the system from the rack and place it on an ESD work bench. For more information, see the *Rail Installation Guide* at www.dell.com/xcseriesmanuals.

Steps

1. Align the tabs on the system cover with the guide slots on the system.
2. Slide the cover towards the front of the system, until the system cover locks in place.
3. Using a 1/4 inch flat head or Phillips #2 screwdriver, turn the lock clockwise to the lock position.



Figure 17. Installing system cover

Next steps

1. [Close the drive bays](#)
2. Place the system into the rack. For more information, see the *Rail Installation Guide* at www.dell.com/xcseriesmanuals.
3. [Open the drive bays](#), install **all drives**, and then [close the drive bays](#).
4. Install the [power supply units](#).
5. Follow the procedure listed in [After working inside your system](#).

Air shroud

Removing the air shroud

Prerequisites

CAUTION: Never operate your system with the air shroud removed. The system may get overheated quickly, resulting in shutdown of the system and loss of data.

1. Follow the safety guidelines listed in [Safety Instructions](#).
2. Power off the system and all attached peripherals.
3. Disconnect the system from the electrical outlet, and disconnect the peripherals.
4. [Open the drive bays](#), remove **all drives**, and then [close the drive bays](#).
5. Remove the [power supply units](#).
6. Remove the system from the rack and place it on an ESD work bench. For more information, see the *Rail Installation Guide* available at www.dell.com/xcseriesmanuals.
7. [Remove the system cover](#).
8. If installed, [remove the butterfly riser](#).

Steps

Lift the air shroud away from the system.

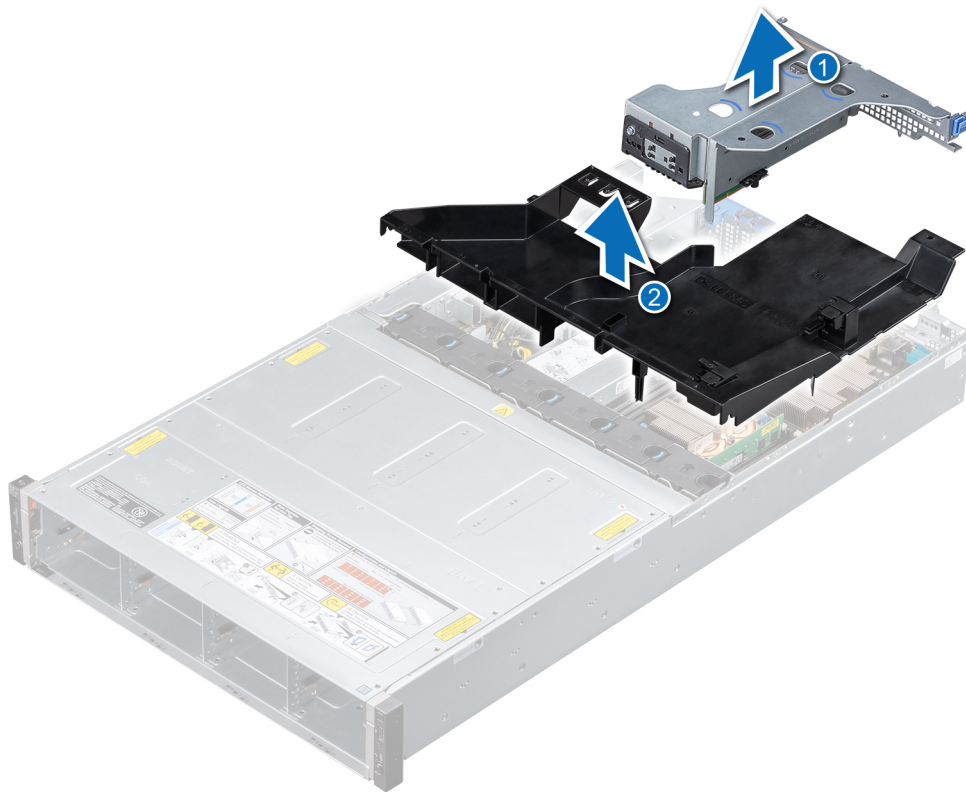

Figure 18. Removing air shroud

Next steps

Replace the air shroud.

Installing the air shroud

Prerequisites

1. Follow the safety guidelines listed in [Safety Instructions](#).
2. Power off the system and all attached peripherals.
3. Disconnect the system from the electrical outlet, and disconnect the peripherals.
4. Ensure that all internal cables are routed correctly and connected, and no tools or extra parts are left inside the system.
5. [Open the drive bays](#), remove **all drives**, and then [close the drive bays](#).
6. Remove the [power supply units](#).
7. Remove the system from the rack and place it on an ESD work bench. For more information, see the *Rail Installation Guide* at www.dell.com/xcseriesmanuals.
8. [Remove the system cover](#).
9. If installed, [remove the butterfly riser](#).

Steps

1. Align the slots on the air shroud with the guide pin on the system.
i **NOTE:** Route the cable properly to prevent the cable from being pinched or crimped.
2. Lower the air shroud into the system until it is firmly seated.

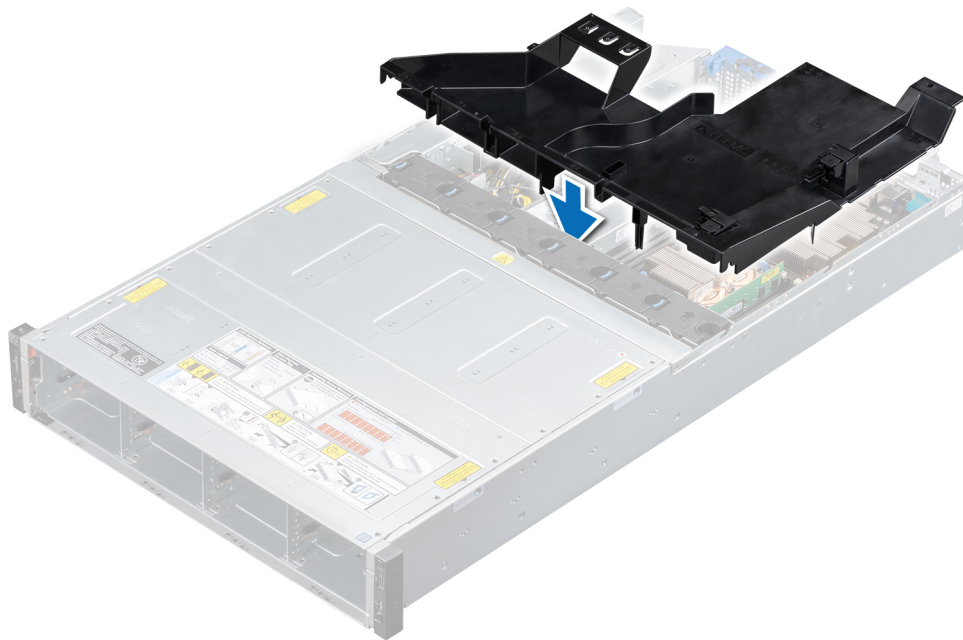

Figure 19. Installing air shroud

Next steps

1. If removed, [install the butterfly riser](#).
2. Install the [system cover](#).
3. Place the system into the rack. For more information, see the *Rail Installation Guide* at www.dell.com/xcseriesmanuals.
4. [Open the drive bays](#), install [all drives](#), and then [close the drive bays](#).
5. Install the [power supply units](#).
6. Follow the procedure listed in [After working inside your system](#).

Internal PERC riser

Removing the internal PERC riser

Prerequisites

1. Follow the safety guidelines listed in [Safety Instructions](#).
2. Power off the system and all attached peripherals.
3. Disconnect the system from the electrical outlet, and disconnect the peripherals.
4. [Open the drive bays](#), remove [all drives](#), and then [close the drive bays](#).
5. Remove the [power supply units](#).
6. Remove the system from the rack and place it on an ESD work bench. For more information, see the *Rail Installation Guide* at www.dell.com/xcseriesmanuals.
7. [Remove the system cover](#).
8. [Remove the air shroud](#).
9. Open the cable guiding latch for easy access.

Steps

1. Lower the plunger and holding the blue touch points, lift the internal PERC riser out of the system.

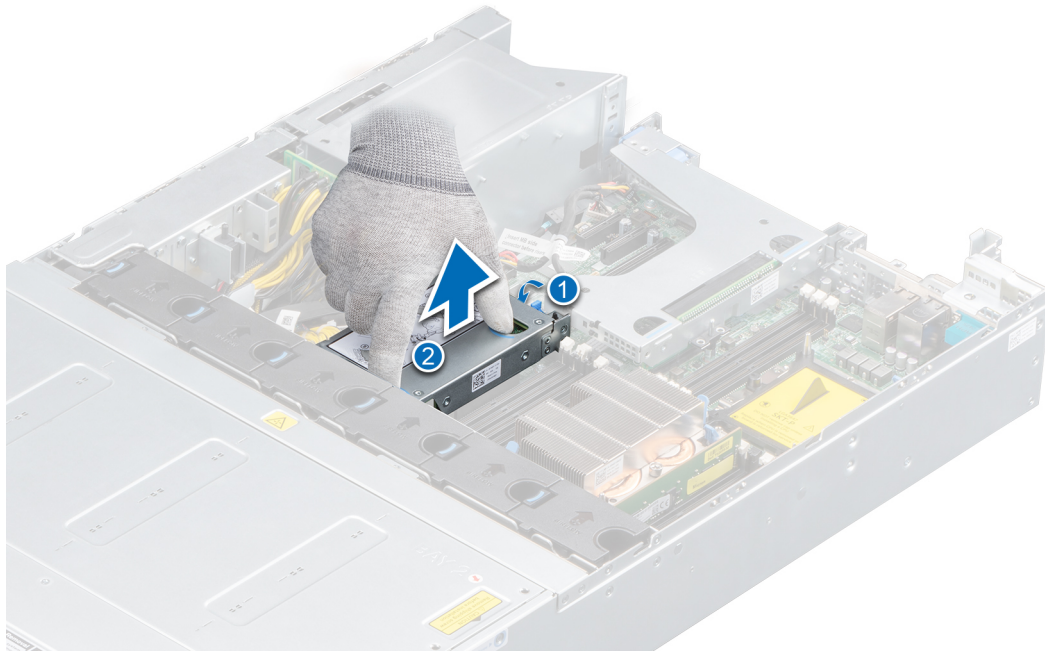

Figure 20. Removing internal PERC riser

2. Turn over the internal riser so that the PERC card is facing up.
3. Using a Phillips #2 screwdriver, loosen the screws from the cable connector and disconnect the cable connected to the internal PERC card.

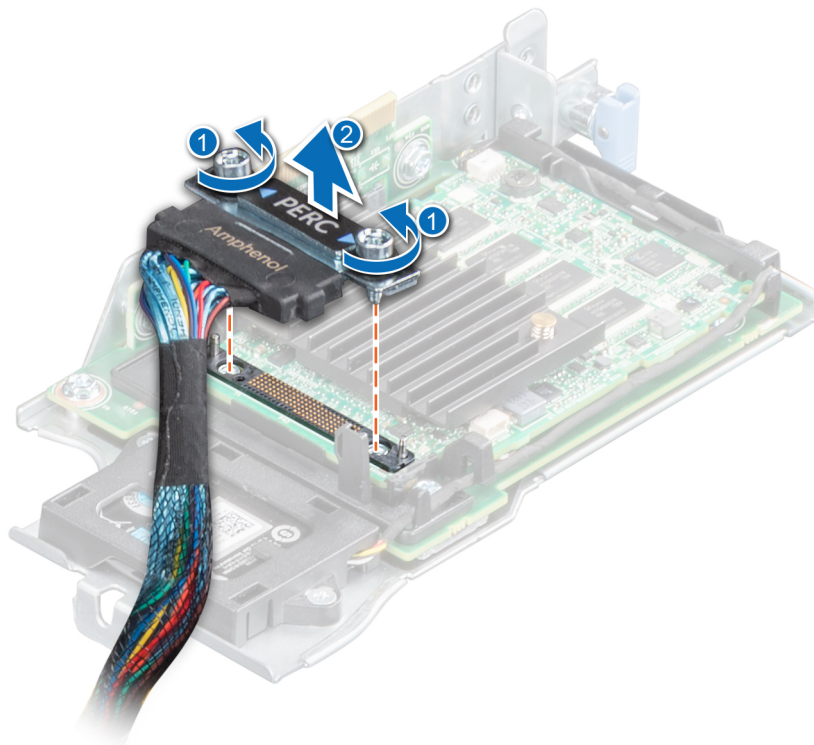

Figure 21. Disconnecting the cable from internal PERC card

Next steps

[Replace the internal PERC riser.](#)

Installing the internal PERC riser

Prerequisites

1. Follow the safety guidelines listed in [Safety Instructions](#).
2. Power off the system and all attached peripherals.
3. Disconnect the system from the electrical outlet, and disconnect the peripherals.
4. Ensure that all internal cables are routed correctly and connected, and no tools or extra parts are left inside the system.
5. [Open the drive bays](#), remove **all drives**, and then [close the drive bays](#).
6. Remove the [power supply units](#).
7. Remove the system from the rack and place it on an ESD work bench. For more information, see the *Rail Installation Guide* at www.dell.com/xcseriesmanuals.
8. [Remove the system cover](#).
9. [Remove the air shroud](#).

Steps

1. Connect the cable connector to the internal PERC card by aligning it to the guiding pins and replace the screws using a Phillips #2 screwdriver.

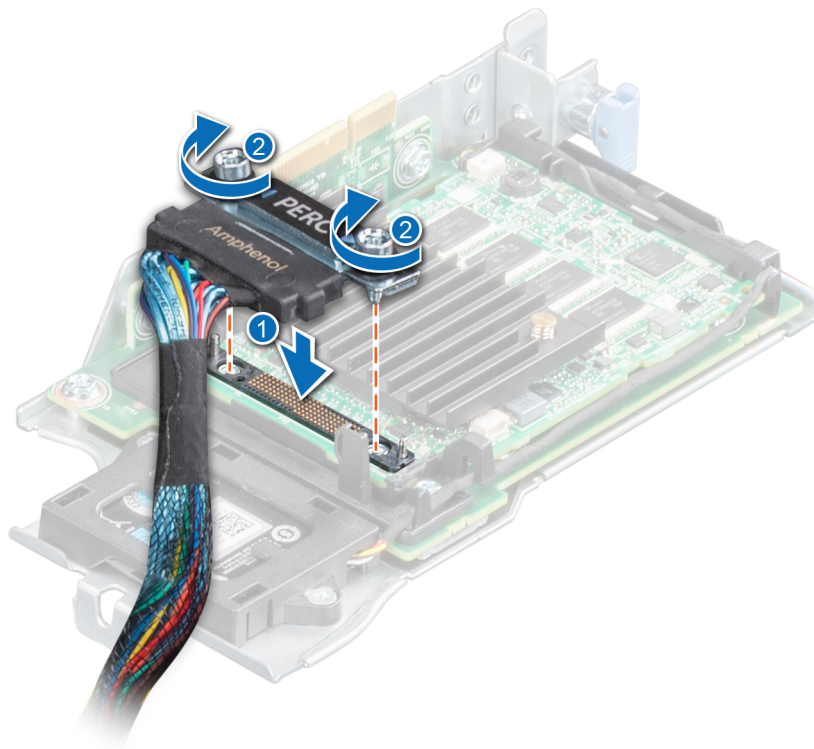

Figure 22. Connecting the cable to internal PERC riser

2. Turn over the internal PERC riser and align the internal PERC riser to the PCI slot by holding the blue touch points, and press until fully seated.
3. Lift the plunger to lock the riser in place.

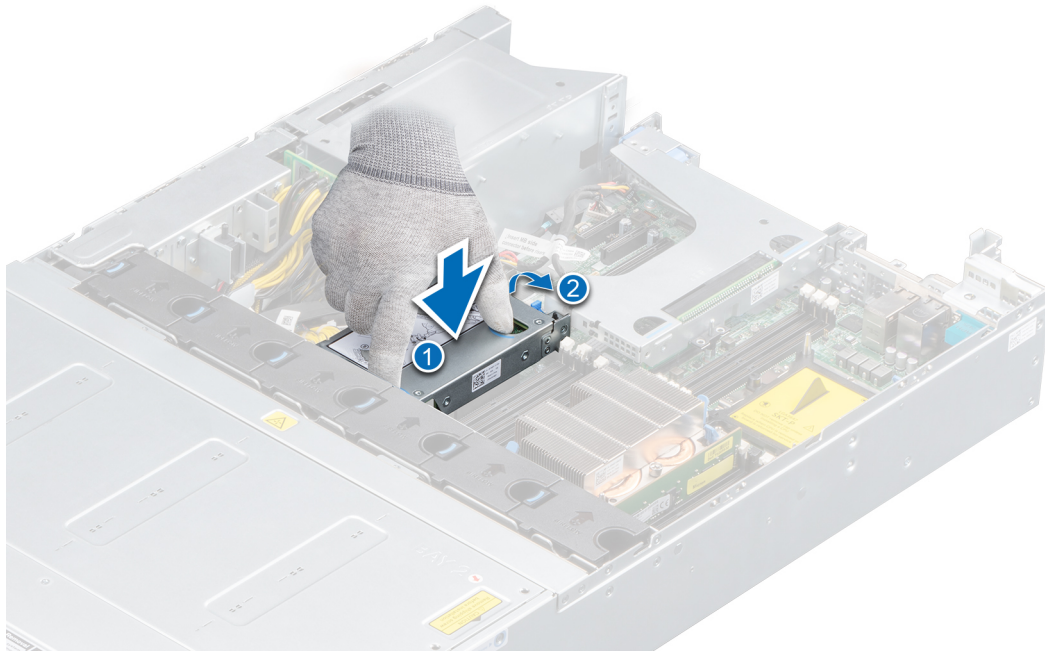

Figure 23. Installing internal PERC riser

Next steps

1. Connect the cables to the backplane and then route the cables to the cable guiding latch and close the latch.
- 2.
3. [Install the air shroud.](#)
4. Install the [system cover.](#)
5. Place the system into the rack. For more information, see the *Rail Installation Guide* at www.dell.com/xcseriesmanuals.
6. [Open the drive bays](#), install [all drives](#), and then [close the drive bays](#).
7. Install the [power supply units](#).
8. Follow the procedure listed in [After working inside your system](#).

Removing the HBA 330 from the internal PERC riser

Prerequisites

1. Follow the safety guidelines listed in [Safety Instructions](#).
2. Power off the system and all attached peripherals.
3. Disconnect the system from the electrical outlet, and disconnect the peripherals.
4. [Open the drive bays](#), remove [all drives](#), and then [close the drive bays](#).
5. Remove the [power supply units](#).
6. Remove the system from the rack and place it on an ESD work bench. For more information, see the *Rail Installation Guide* at www.dell.com/xcseriesmanuals.
7. [Remove the system cover.](#)
8. [Remove the air shroud.](#)
9. [Remove the internal PERC riser.](#)

Steps

Pull the HBA 330 out of the connector on the internal PERC riser.

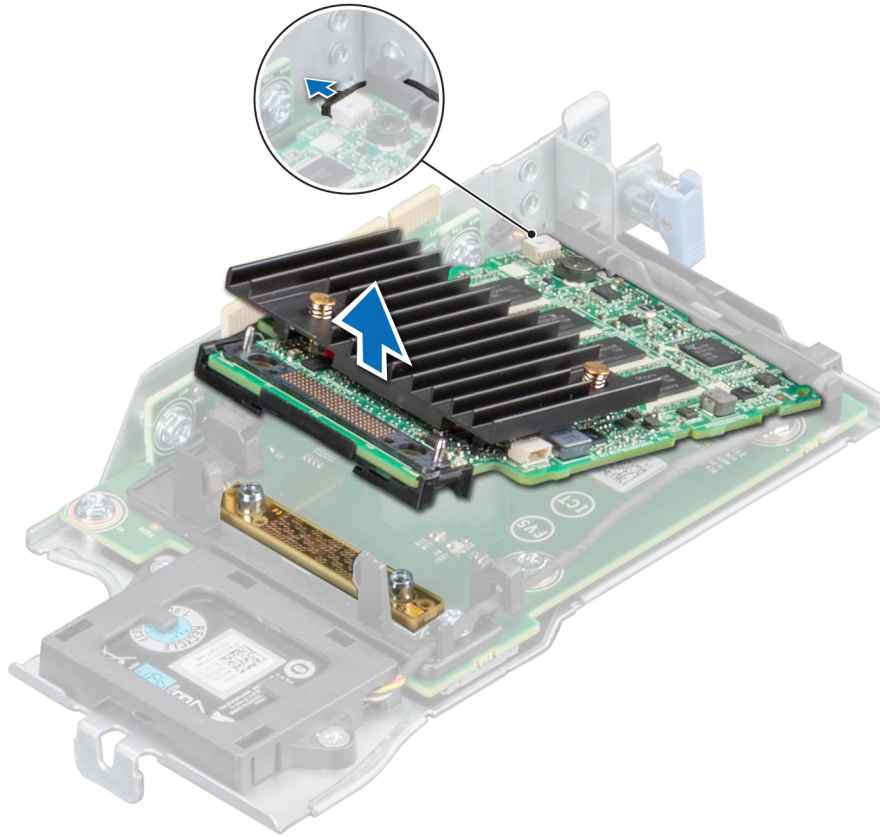

Figure 24. Removing the HBA 330 from the internal PERC riser

Next steps

Replace the PERC card into the PERC riser

Installing PERC card into the internal PERC riser

Prerequisites

1. Follow the safety guidelines listed in [Safety Instructions](#).
2. Power off the system and all attached peripherals.
3. Disconnect the system from the electrical outlet, and disconnect the peripherals.
4. Ensure that all internal cables are routed correctly and connected, and no tools or extra parts are left inside the system.
5. [Open the drive bays](#), remove **all drives**, and then [close the drive bays](#).
6. Remove the [power supply units](#).
7. Remove the system from the rack and place it on an ESD work bench. For more information, see the *Rail Installation Guide* at www.dell.com/xcseriesmanuals.
8. [Remove the system cover](#).
9. [Remove the air shroud](#).
10. [Remove the internal PERC riser](#).

Steps

Align the PERC card to the guiding pins on the internal PERC riser and push the card in.

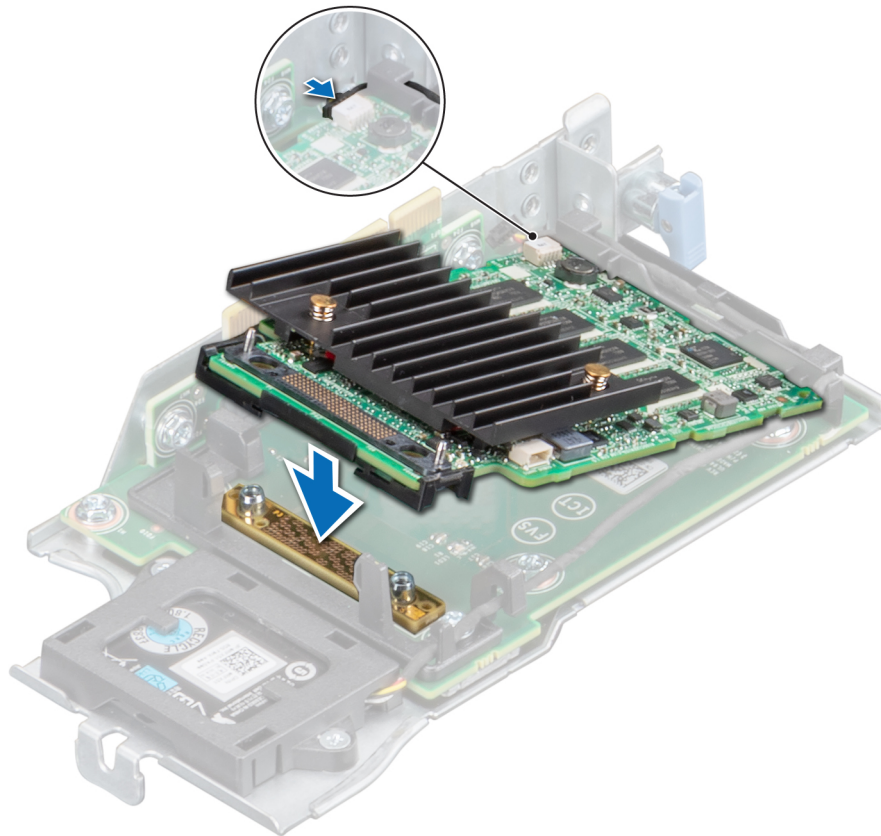

Figure 25. Installing the PERC card into internal PERC riser

Next steps

1. [Install the internal PERC riser](#)
2. [Install the air shroud.](#)
3. Install the [system cover](#).
4. Place the system into the rack. For more information, see the *Rail Installation Guide* at www.dell.com/xcseriesmanuals.
5. [Open the drive bays](#), install [all drives](#), and then [close the drive bays](#).
6. Install the [power supply units](#).
7. Follow the procedure listed in [After working inside your system](#).

Cooling fans

Removing the cooling fan

Prerequisites

1. Follow the safety guidelines listed in [Safety instructions](#).
2. Power off the system and all attached peripherals.
3. Disconnect the system from the electrical outlet, and disconnect the peripherals.
4. [Open the drive bays](#), remove [all drives](#), and then [close the drive bays](#).
5. Remove the [power supply units](#).
6. Remove the system from the rack and place it on an ESD work bench. For more information, see the *Rail Installation Guide* at www.dell.com/xcseriesmanuals.
7. [Remove the system cover](#).
8. [Remove the air shroud](#).
9. [Remove the internal PERC riser](#).
10. Move the cables out of the way to access the cooling fan cable connector on the system board.

Steps

1. Press the tabs on the fan cable connector and disconnect the cable from the system board.
2. Remove the cable from the cable retention tabs.
3. Press the blue release tab and lift the cooling fan from the cooling fan cage.

i **NOTE:** If removing cooling fan 1, remove the fan cable connector from the power interposer board (PIB).

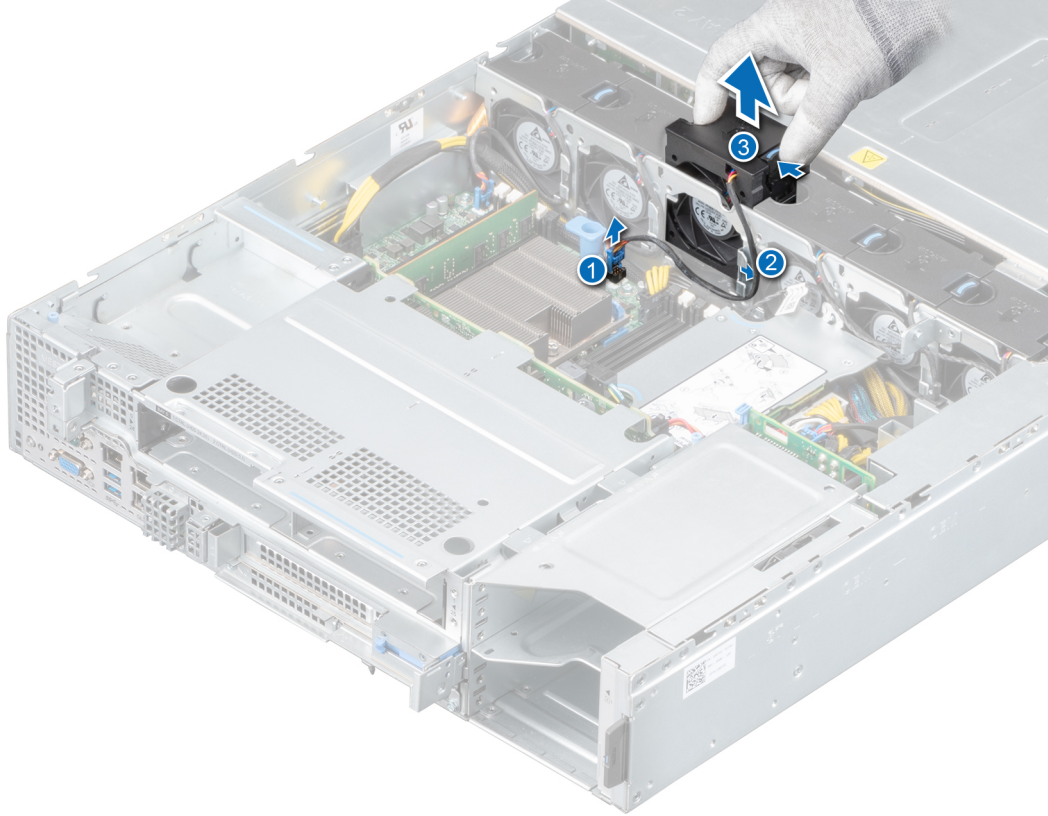

Figure 26. Removing cooling fan

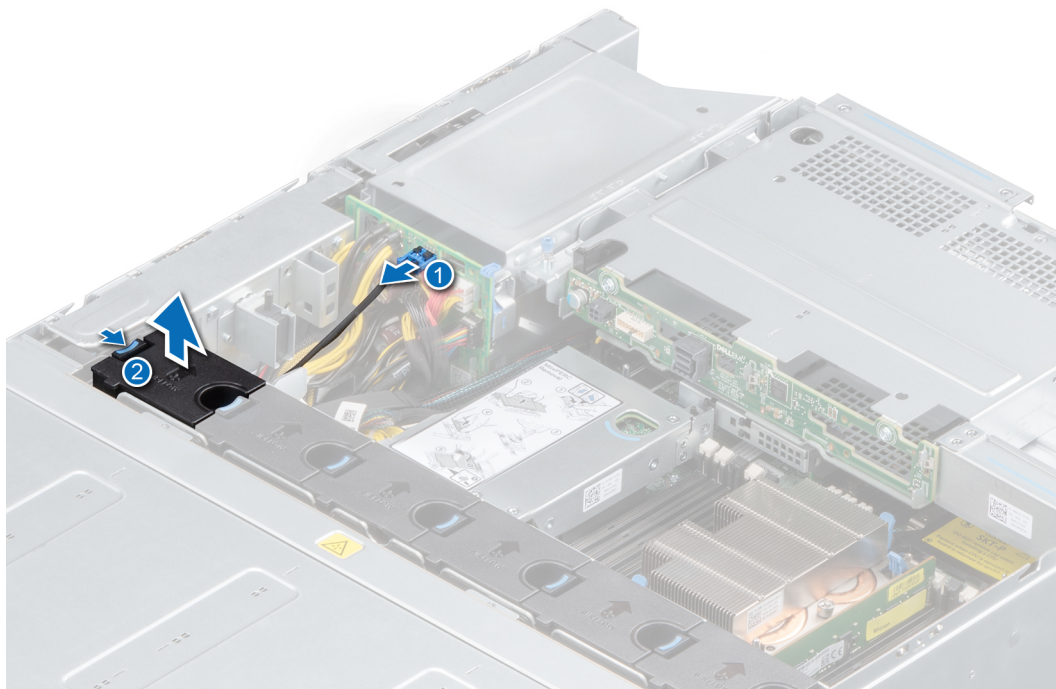

Figure 27. Disconnecting fan 1 cable from PIB connector

Next steps

Replace the cooling fans

Installing cooling fan

Prerequisites

1. Follow the safety guidelines listed in [Safety Instructions](#).
2. Power off the system and all attached peripherals.
3. Disconnect the system from the electrical outlet, and disconnect the peripherals.
4. Ensure that all internal cables are routed correctly and connected, and no tools or extra parts are left inside the system.
5. [Open the drive bays](#), remove [all drives](#), and then [close the drive bays](#).
6. Remove the [power supply units](#).
7. Remove the system from the rack and place it on an ESD work bench. For more information, see the *Rail Installation Guide* at www.dell.com/xcseriesmanuals.
8. [Remove the system cover](#).
9. [Remove the air shroud](#).
10. [Remove the internal PERC riser](#).
11. Move the cables out of the way to access the cooling fan cable connector on the system board.

Steps

1. Lower the cooling fan into the cooling fan cage, until the blue release tab clicks into place.
2. Route the cable through the cable retention tabs.
3. Connect the power cable to the connector on the system board.

(i) NOTE: If installing cooling fan 1, connect the fan cable connector to the power interposer board (PIB).

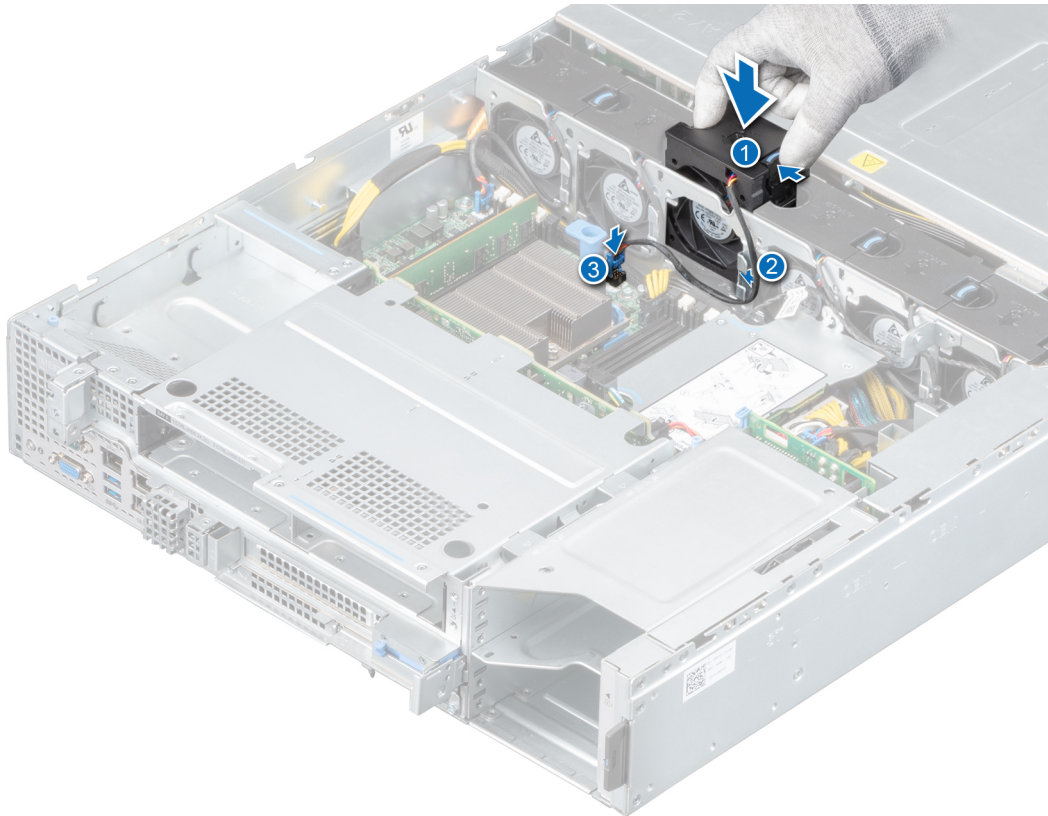

Figure 28. Installing cooling fan

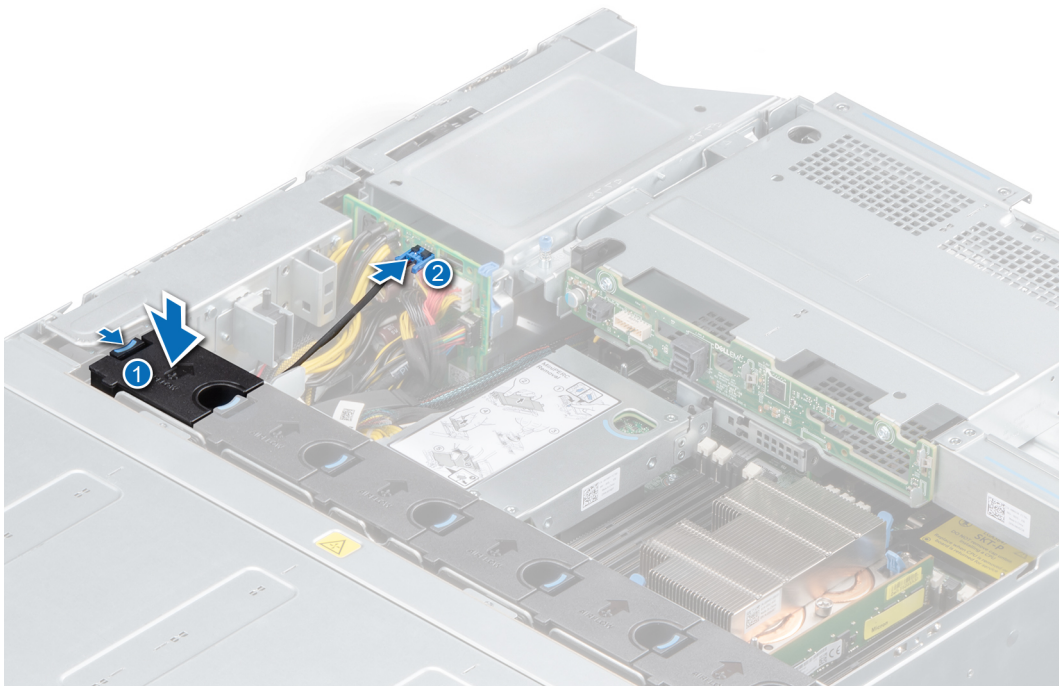

Figure 29. Connecting fan 1 cable to PIB connector

Next steps

1. Install the internal PERC riser
2. Install the air shroud.
3. Install the system cover.

4. Place the system into the rack. For more information, see the *Rail Installation Guide* at www.dell.com/xcseriesmanuals.
5. [Open the drive bays](#), install [all drives](#), and then [close the drive bays](#).
6. Install the [power supply units](#).
7. Follow the procedure listed in [After working inside your system](#).

Intrusion switch

Removing the intrusion switch

Prerequisites

1. Follow the safety guidelines listed in [Safety Instructions](#).
2. Power off the system and all attached peripherals.
3. Disconnect the system from the electrical outlet, and disconnect the peripherals.
4. [Open the drive bays](#), remove [all drives](#), and then [close the drive bays](#).
5. Remove the [power supply units](#).
6. Remove the system from the rack and place it on an ESD work bench. For more information, see the *Rail Installation Guide* at www.dell.com/xcseriesmanuals.
7. [Remove the system cover](#).
8. [Remove the air shroud](#).
9. [Remove the internal PERC riser](#).

Steps

1. Disconnect and remove the intrusion switch cable from the system board.

NOTE: Observe the routing of the cable as you remove it from the system. Route the cable properly when you replace it to prevent the cable from being pinched or crimped.

2. Using a plastic scribe, slide the intrusion switch from the slot.

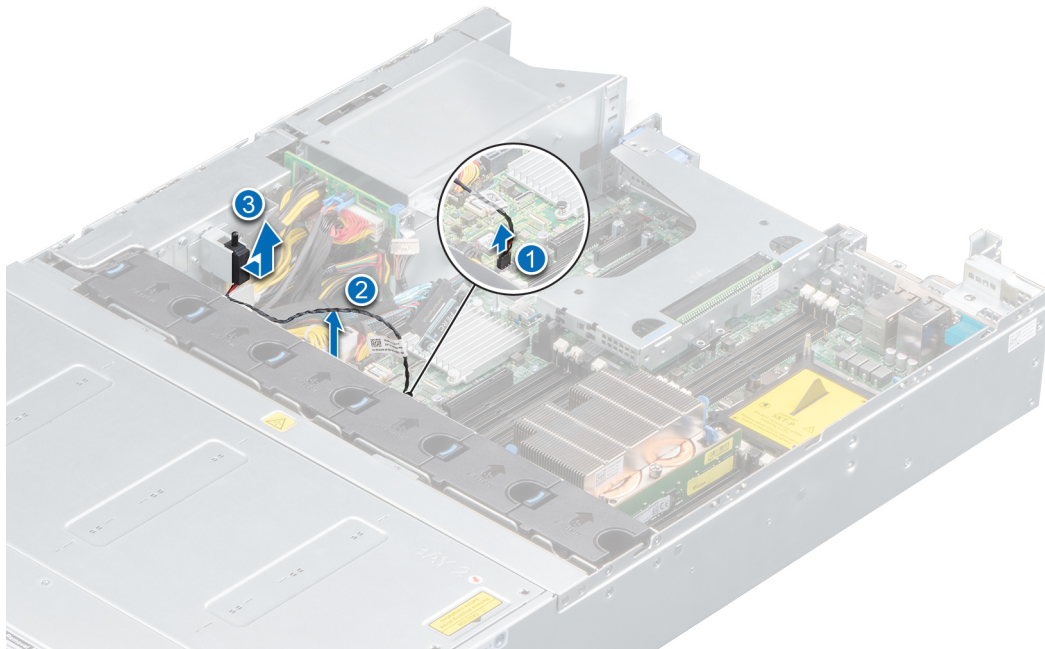

Figure 30. Removing the intrusion switch

Next steps

[Replace the intrusion switch](#).

Installing the intrusion switch

Prerequisites

1. Follow the safety guidelines listed in [Safety Instructions](#).
2. Power off the system and all attached peripherals.
3. Disconnect the system from the electrical outlet, and disconnect the peripherals.
4. Ensure that all internal cables are routed correctly and connected, and no tools or extra parts are left inside the system.
5. [Open the drive bays](#), remove **all drives**, and then [close the drive bays](#).
6. Remove the [power supply units](#).
7. Remove the system from the rack and place it on an ESD work bench. For more information, see the *Rail Installation Guide* at www.dell.com/xcseriesmanuals.
8. [Remove the system cover](#).
9. [Remove the air shroud](#).
10. [Remove the internal PERC riser](#).

Steps

1. Align and slide intrusion switch into the slot in the system.

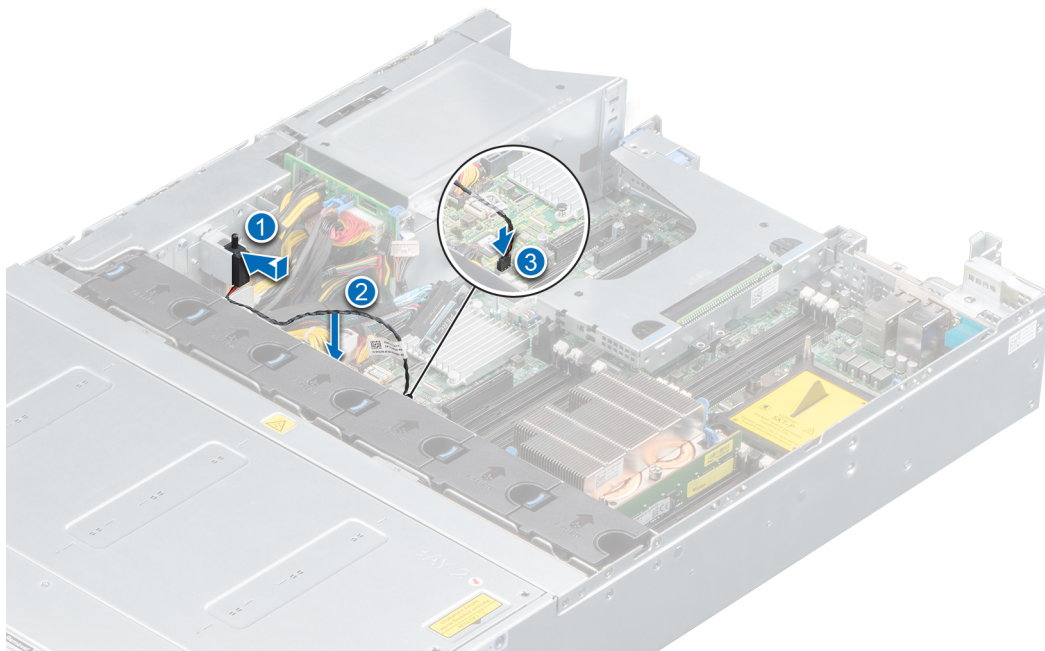

Figure 31. Installing the intrusion switch

2. Connect the intrusion switch cable to the connector on the system board.

NOTE: Route the cable properly when you replace it to prevent the cable from being pinched or crimped.

Next steps

1. [Install the internal PERC riser](#)
2. [Install the air shroud](#).
3. Install the [system cover](#).
4. Place the system into the rack. For more information, see the *Rail Installation Guide* at www.dell.com/xcseriesmanuals.
5. [Open the drive bays](#), install **all drives**, and then [close the drive bays](#).
6. Install the [power supply units](#).
7. Follow the procedure listed in [After working inside your system](#).

Drive bay

Opening the drive bays

Prerequisites

CAUTION: Drive bays should not be in service position for more than 5 minutes because of thermal concerns. When the drive bay is open for more than five minutes, the cooling fans spin at a higher speed to provide extra cooling to the system. Thus system health status changes from the normal to critical state, and system event "The BP1 drive bay is kept open for an extended period of time" is logged.

1. Follow the safety guidelines listed in [Safety Instructions](#).
2. If installed, [remove front bezel](#).

Steps

1. If locked, unlock the drive bay lock located above the left release latch, by pushing it up.
2. Open the release latches of drive bay 1 and pull the drive bays out.



Figure 32. Opening the drive bays

Next steps

1. If installed, [remove a drive blank](#) or [install a drive blank](#).
2. If installed, [remove a drive carrier](#) or [install a drive carrier](#).

Closing the drive bays

Prerequisites

1. Follow the safety guidelines listed in [Safety Instructions](#).
2. If installed, [remove front bezel](#).

Steps

1. Pull back the blue release tabs on both sides and slide the drive bays into the system, until both the bays lock into place.



Figure 33. Closing drive bays

2. If required, lock the drive bay lock located above left release latch, by pushing it down.

Next steps

If removed, [install front bezel](#).

Drives

Removing a drive blank

Prerequisites

1. Follow the safety guidelines listed in [Safety Instructions](#).
2. If installed, [remove the front bezel](#).

CAUTION: To maintain proper system cooling, drive blanks must be installed in all empty drive slots.

CAUTION: Mixing drive blanks from previous generations of XC systems is not supported.

Steps

Press the release button, and slide the drive blank out of the drive slot.

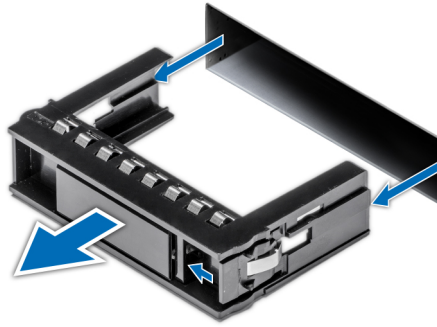

Figure 34. Removing a drive blank

Next steps

Replace a drive blank.

Installing a drive blank

Prerequisites

1. Follow the safety guidelines listed in [Safety Instructions](#)
2. If installed, [remove the front bezel](#)

CAUTION: To maintain proper system cooling, drive blanks must be installed in all empty drive slots.

CAUTION: Mixing drive blanks from previous generations of XC systems is not supported.

Steps

Insert the drive blank into the drive slot, and push the blank until the release button clicks into place.

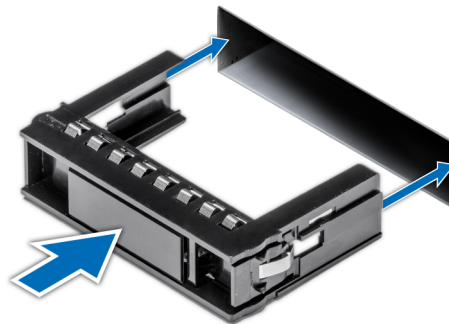

Figure 35. Installing a drive blank

Next steps

If removed, [install front bezel](#).

Removing a drive carrier

Prerequisites

1. Follow the safety guidelines listed in [Safety Instructions](#).
2. If installed, [remove the front bezel](#).
3. Using the management software, prepare the drive for removal.

If the drive is online, the green activity or fault indicator flashes while the drive is turning off. When the drive indicators are off, the drive is ready for removal. For more information, see the documentation for the storage controller.

CAUTION: Before attempting to remove or install a drive while the system is running, see the documentation for the storage controller card to ensure that the host adapter is configured correctly to support drive removal and insertion.

CAUTION: Mixing drives from previous generations of XC systems is not supported.

CAUTION: To prevent data loss, ensure that your operating system supports drive installation. See the documentation supplied with your operating system.

Steps

1. Press the release button to open the drive carrier release handle.
2. Holding the handle, slide the drive carrier out of the drive slot.

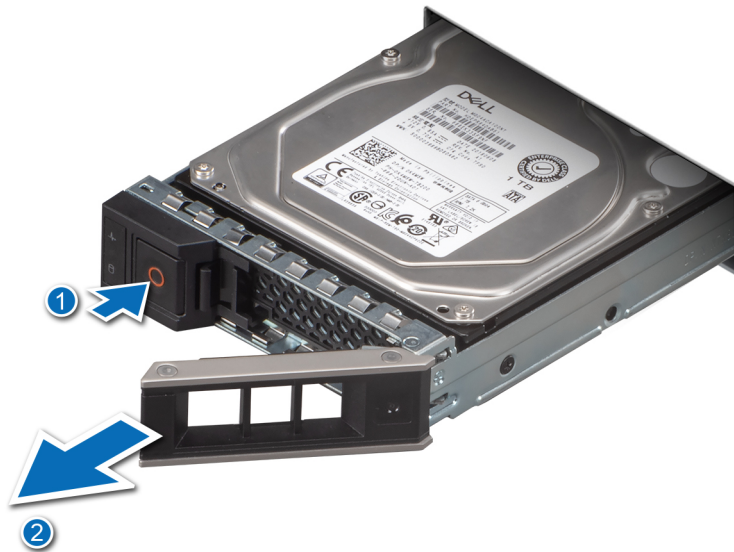

Figure 36. Removing a drive carrier

Next steps

1. [Replace a drive carrier.](#)
2. If you are not replacing the drive immediately, [insert a drive blank](#) in the empty drive slot to maintain proper system cooling.

Installing a drive carrier

Prerequisites

CAUTION: Before attempting to remove or install a drive while the system is running, see the documentation for the storage controller card to ensure that the host adapter is configured correctly to support drive removal and insertion.

CAUTION: Mixing drives from previous generations of XC systems is not supported.

CAUTION: Combining SAS and SATA drives in the same RAID volume is not supported.

CAUTION: When installing a drive, ensure that the adjacent drives are installed correctly. Inserting a drive carrier and attempting to lock its handle next to a incorrectly installed carrier can damage the incorrectly installed carrier's shield spring, making it unusable.

CAUTION: To prevent data loss, ensure that your operating system supports hot-swap drive installation. See the documentation supplied with your operating system.

NOTE: When a replacement hot swappable drive is installed while the system is powered on, the drive automatically begins to rebuild. Ensure that the replacement drive is blank. Any data on the replacement drive is immediately lost once the drive is installed.

1. Follow the safety guidelines listed in [Safety Instructions](#).
2. If installed, [remove the drive blank](#).

NOTE: To avoid the metal stops from bending in the drive cage in the drive bays, populate the drives in a bottom to top order.

Steps

1. Press the release button on the front of the drive carrier to open the release handle.
2. Insert and slide the drive carrier into the drive slot.
3. Close the drive carrier release handle until it clicks in place.



Figure 37. Installing a drive carrier

Next steps

If removed, [install the front bezel](#).

Removing the drive from the drive carrier

Prerequisites

CAUTION: Mixing drives from previous generations of XC systems is not supported.

Steps

1. Using a Phillips #1 screwdriver, remove the screws from the slide rails on the drive carrier.
2. Lift the drive out of the drive carrier.

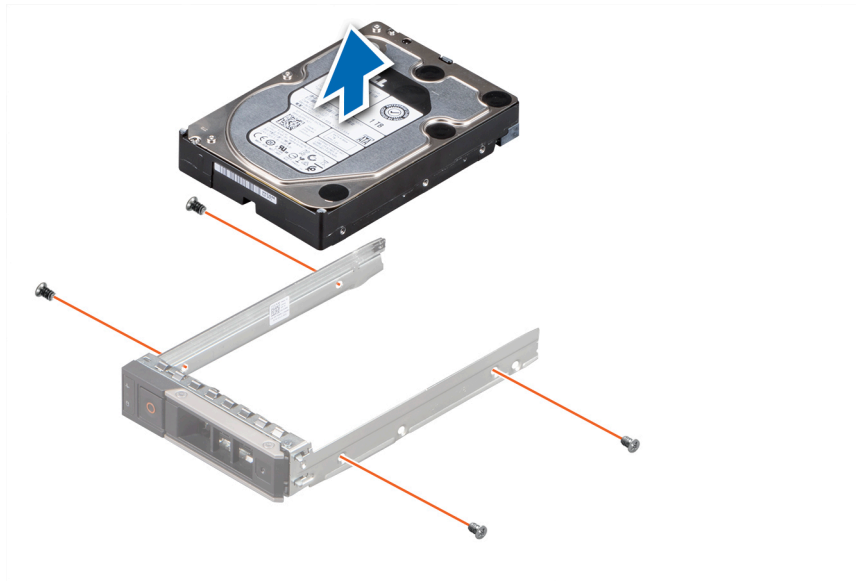

Figure 38. Removing the drive from the drive carrier

Next steps

If applicable, [install a drive into the drive carrier](#).

Installing a drive into the drive carrier

Prerequisites

CAUTION: Mixing drive carriers from other generations of XC systems is not supported.

NOTE: When installing a drive into the drive carrier, ensure that the screws are torqued to 4 inch-pounds.

Steps

1. Insert the drive into the drive carrier with the connector end of the drive towards the back of the carrier.
2. Align the screw holes on the drive with the screws holes on the drive carrier.
3. Using a Phillips #1 screwdriver, replace the screws to secure the drive to the drive carrier.

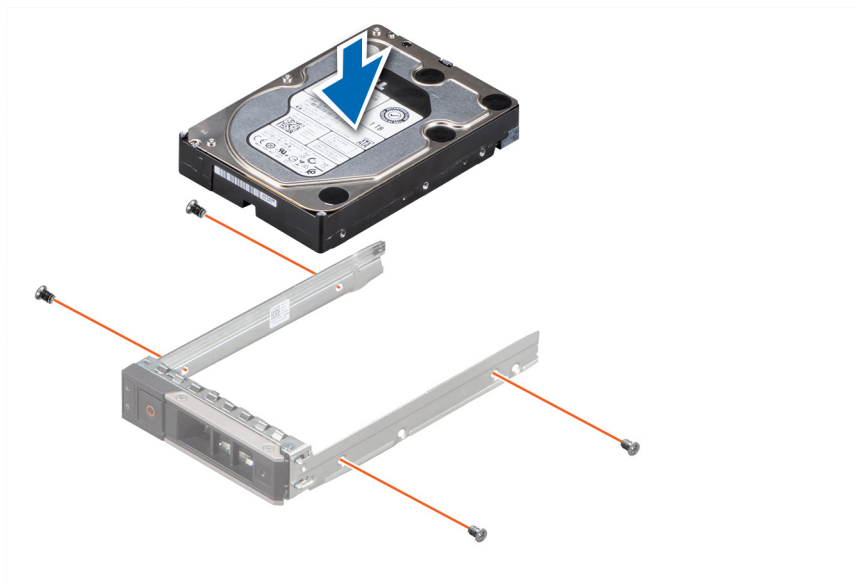

Figure 39. Installing a drive into the drive carrier

Next steps

[Install the drive carrier.](#)

Removing a 2.5-inch drive from a 3.5-inch drive adapter

Prerequisites

NOTE: A 2.5-inch drive is installed in a 3.5-inch drive adapter, which is then installed in the 3.5-inch drive carrier.

Steps

1. Using a Phillips #2 screwdriver, remove the screws from the side of the 3.5-inch drive adapter.
2. Remove the 2.5-inch drive from the 3.5-inch drive adapter.

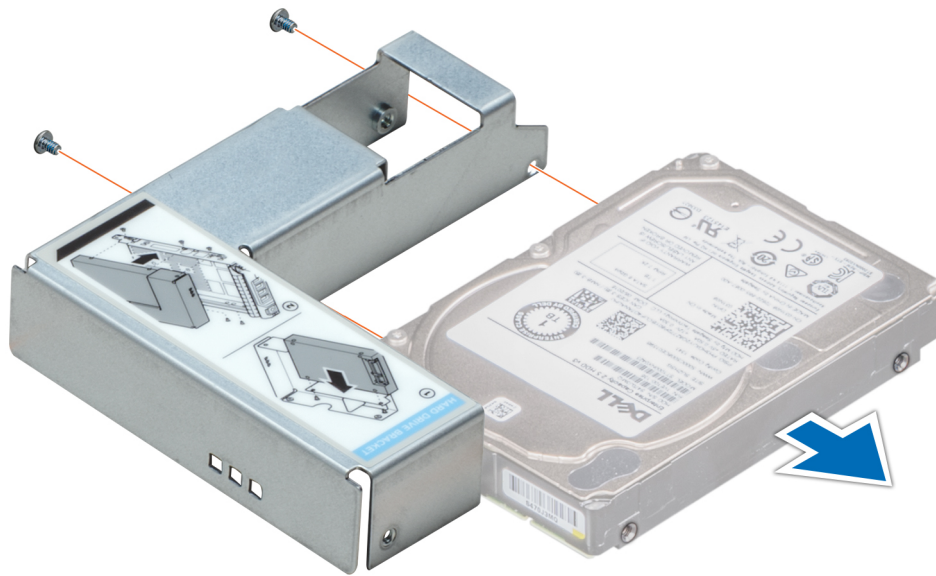

Figure 40. Removing a 2.5 inch drive from a 3.5-inch drive adapter

Next steps

[Replace a 2.5-inch drive into a 3.5-inch drive adapter.](#)

Installing a 2.5-inch drive into a 3.5-inch drive adapter

Prerequisites

1. Follow the safety guidelines listed in [Safety Instructions](#).
2. [Remove the drive carrier.](#)

Steps

1. Align the screw holes on the 2.5-inch drive with the screw holes on the 3.5-inch drive adapter.
2. Using a Phillips #2 screwdriver, secure the 2.5-inch drive to the 3.5-inch drive adapter.

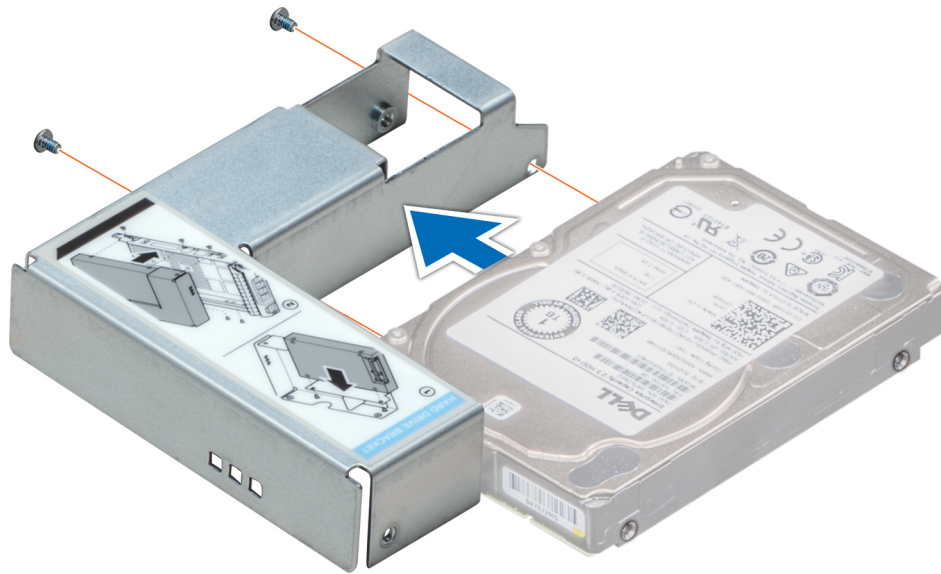

Figure 41. Installing a 2.5-inch drive into a 3.5-inch drive adapter

Removing a 3.5-inch drive adapter from a 3.5-inch drive carrier

Prerequisites

1. Follow the safety guidelines listed in [Safety Instructions](#).

Steps

1. Using a Phillips #1 screwdriver, remove the screws from the rails on the drive carrier.
2. Lift the 3.5-inch drive adapter out of the 3.5-inch drive carrier.

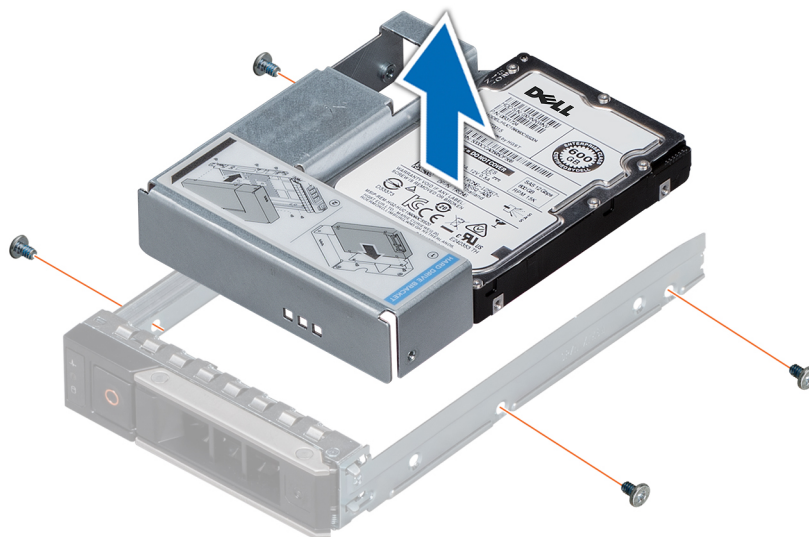

Figure 42. Removing a 3.5-inch drive adapter from a 3.5-inch drive carrier

Drive backplane bracket

Removing the drive bay 1 backplane bracket

Prerequisites

NOTE: Ensure that the drive bay 1 and 2 is in open position to access the backplane bracket.

1. Follow the safety guidelines listed in [Safety Instructions](#).
2. Follow the procedure listed in [Before working inside your system](#)
3. If installed, [remove the front bezel](#).
4. [Remove all the drives from drive bay 1](#)
5. [Open the drive bays](#)

Steps

1. Using a Phillips #1 screwdriver, remove the screws on top of the drive bay 1.
2. Slide the bracket to the right to disengage it from the slots at the bay base in drive bay 1.
3. Lift the bracket away from the system.

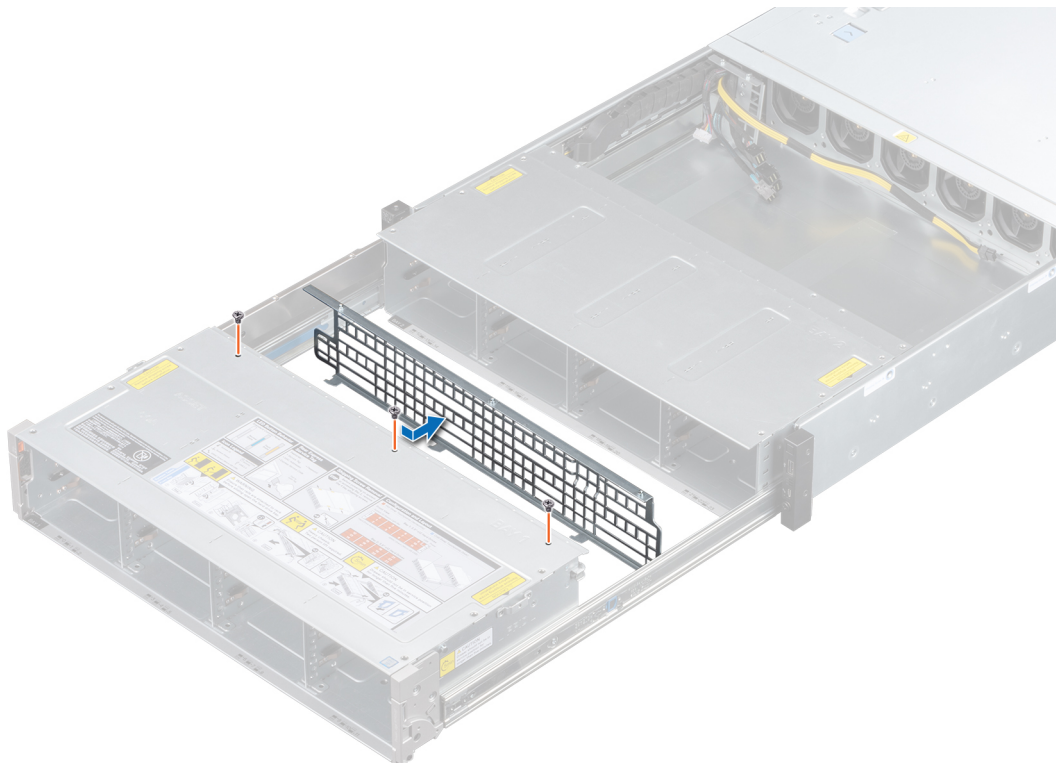

Figure 43. Removing bay 1 backplane bracket

Installing the drive bay 1 backplane bracket

Prerequisites

Follow the safety guidelines listed in [Safety Instructions](#).

1. Follow the procedure listed in [Before working inside your system](#).
2. If installed, [remove the front bezel](#).
3. [Remove all the drives from drive bay 1](#).
4. [Open the drive bays](#).

Steps

1. Align the backplane bracket with the two slots at the bay base in drive bay 1.
2. Slide the bracket to the left until it is firmly seated and locks into place.
3. Using a Phillips #1 screwdriver, tighten the screws on top of the drive bay to secure the bracket.

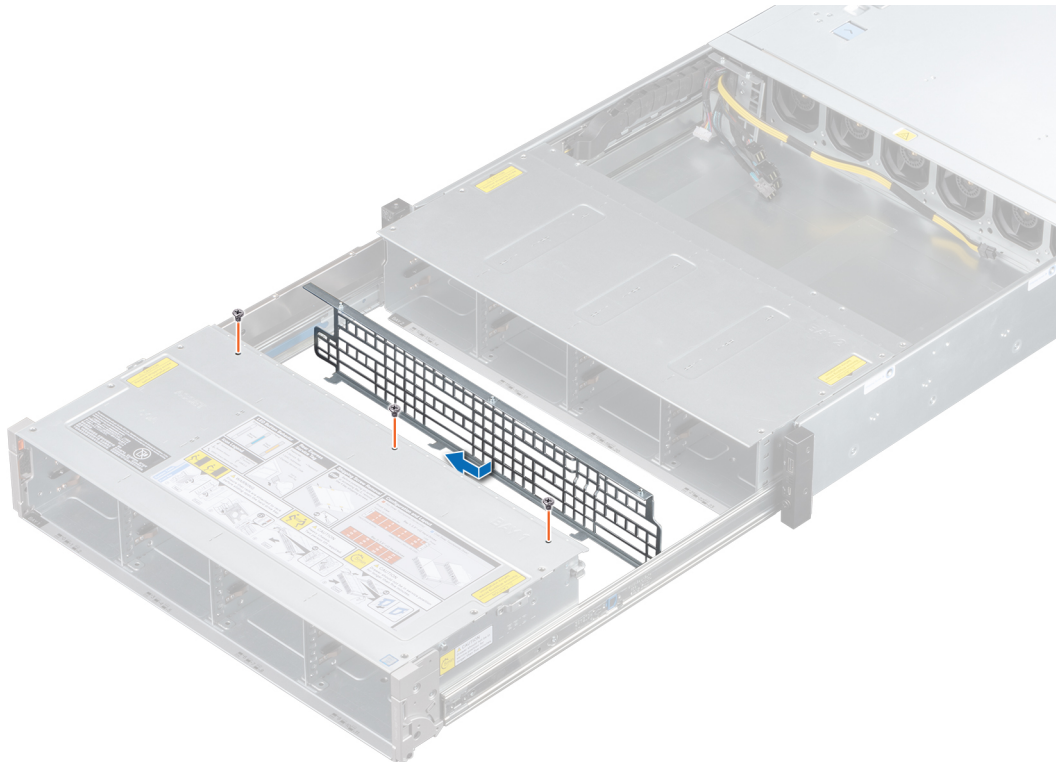

Figure 44. Installing bay 1 backplane bracket

Next steps

1. [Install all the drives.](#)
2. [Close the drive bays.](#)
3. If removed, [install the front bezel.](#)
4. Follow the procedure listed in [After working inside your system.](#)

Removing the drive bay 2 backplane brackets

Prerequisites

1. Follow the safety guidelines listed in [Safety instructions.](#)
2. Power off the system and all attached peripherals.
3. Disconnect the system from the electrical outlet, and disconnect the peripherals.
4. If installed, [remove the front bezel.](#)
5. [Open the drive bays](#), remove [all drives](#), and then [close the drive bays.](#)
6. Remove the [power supply units.](#)
7. Remove the system from the rack and place it on an ESD work bench. For more information, see the *Rail Installation Guide* at www.dell.com/xcseriesmanuals.
8. [Open the drive bays.](#)

Steps

1. Using a Phillips #1 screwdriver, remove the screws on the top of the drive bay 2, securing the backplane brackets.
2. Disconnect the cables of the cable chain assembly connected to the backplane.
3. Slide the brackets to the right to disengage them from the slots on the bay base in drive bay 2.
4. Lift the right bracket away from the system and move the left bracket away from the drive bay.

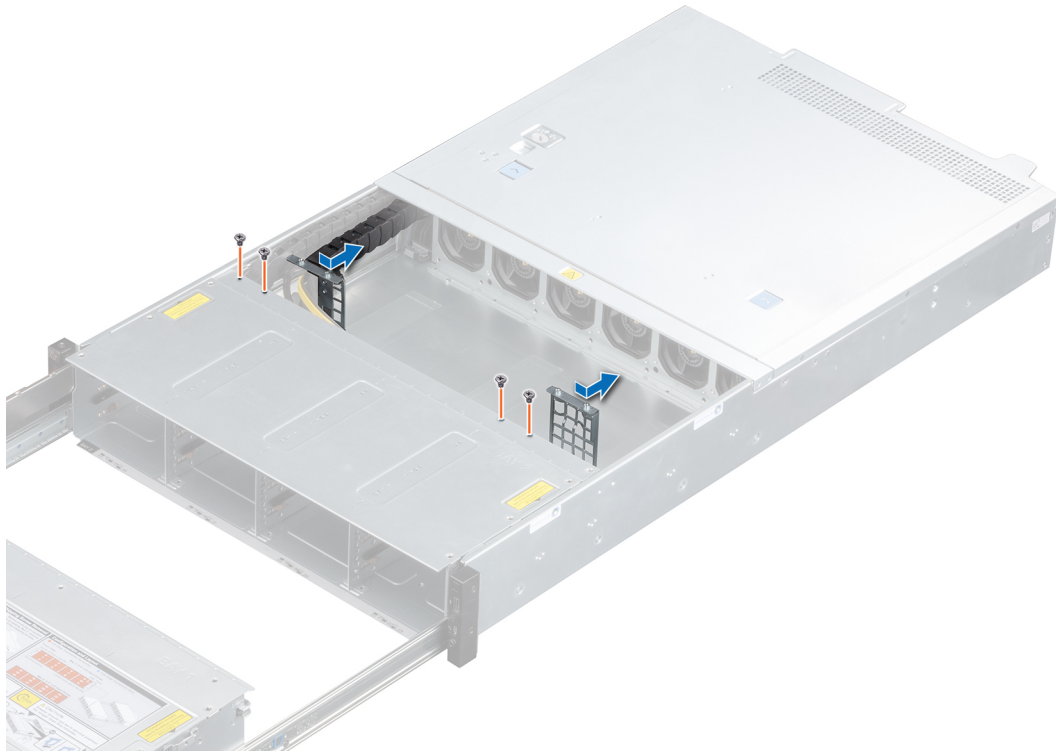

Figure 45. Removing bay 2 backplane brackets

Next steps

Replace the drive bay 2 backplane brackets.

Installing the drive bay 2 backplane brackets

Prerequisites

1. Follow the safety guidelines listed in [Safety Instructions](#).
2. Power off the system and all attached peripherals.
3. Disconnect the system from the electrical outlet, and disconnect the peripherals.
4. Ensure that all internal cables are routed correctly and connected, and no tools or extra parts are left inside the system.
5. If installed, [remove the front bezel](#).
6. [Open the drive bays](#), remove [all drives](#), and then [close the drive bays](#).
7. Remove the [power supply units](#).
8. Remove the system from the rack and place it on an ESD work bench. For more information, see the *Rail Installation Guide* at www.dell.com/xcseriesmanuals.
9. [Open the drive bays](#)

Steps

1. Align the backplane brackets with the slots at the bay base in drive bay 2.
2. Slide the brackets to the right until the brackets are firmly seated and lock into the place.
3. Using a Phillips #1 screwdriver, replace the screws on top of the drive bay 2.

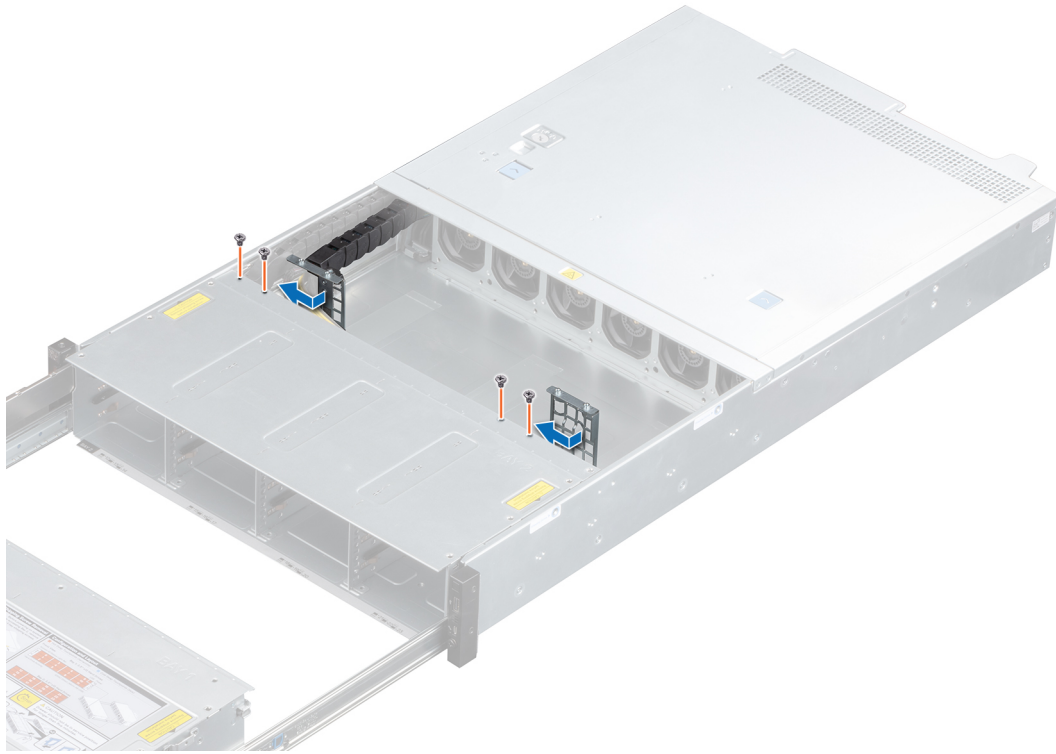

Figure 46. Installing bay 2 backplane brackets

Next steps

1. Place the system into the rack. For more information, see the *Rail Installation Guide* at www.dell.com/xcseriesmanuals.
2. [Open the drive bays](#), install *all drives*, and then [close the drive bays](#).
3. Install the [power supply units](#).
4. If removed, [install the front bezel](#)
5. Follow the procedure listed in [After working inside your system](#).

Bay intrusion switch

Removing bay intrusion switch

Prerequisites

1. Follow the safety guidelines listed in [Safety Instructions](#).
2. Follow the procedure listed in [Before working inside your system](#).
3. If installed, [remove the front bezel](#).
4. [Open the drive bays](#).
5. [Remove the drive bay 1 bracket](#).

Steps

1. Disconnect the intrusion switch cable connected to the backplane of drive bay 1.
2. Using a Phillips #1 screwdriver, remove the screws securing the intrusion switch to the intrusion switch slot.
3. Disengage the intrusion switch from the intrusion switch slot and remove it from the system.

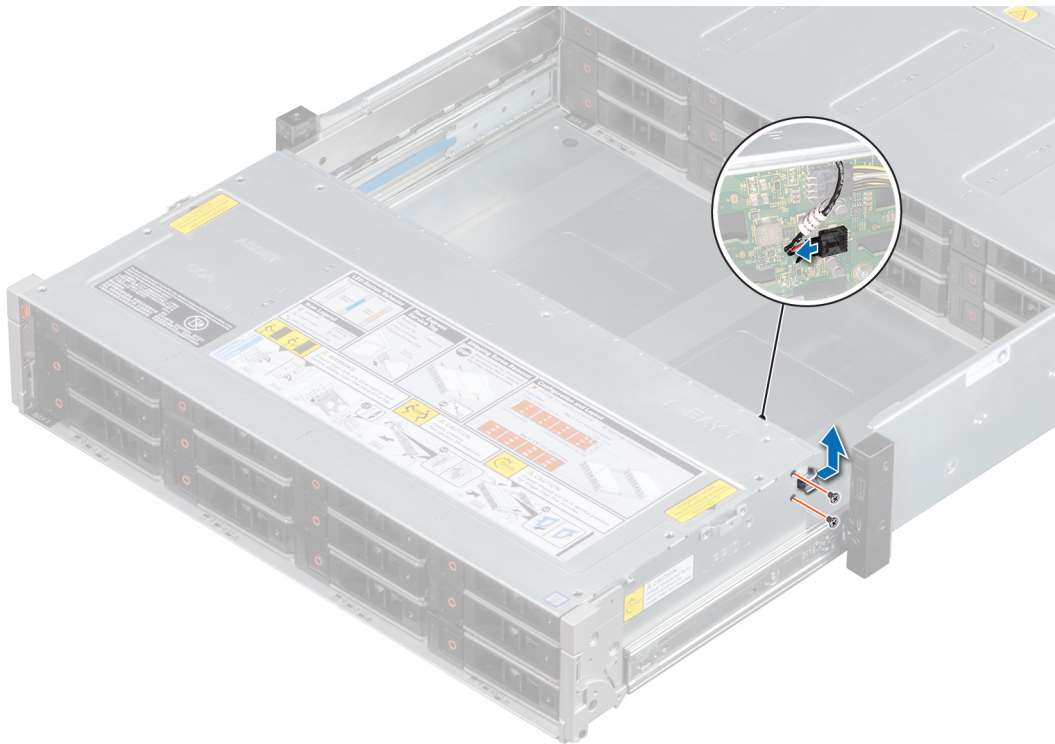

Figure 47. Removing the bay intrusion switch

Next steps

Replace the bay intrusion switch.

Installing bay intrusion switch

Prerequisites

1. Follow the safety guidelines listed in [Safety Instructions](#).
2. Follow the procedure listed in [Before working inside your system](#).
3. If installed, [remove the front bezel](#).
4. [Open the drive bays](#).
5. [Remove the drive bay 1 bracket](#).

Steps

1. Align the intrusion switch to the intrusion switch slot in drive bay 1.
2. Using a Phillips #1 screwdriver, replace the screws to secure the intrusion switch.
3. Connect the intrusion cable to the backplane of drive bay 1.

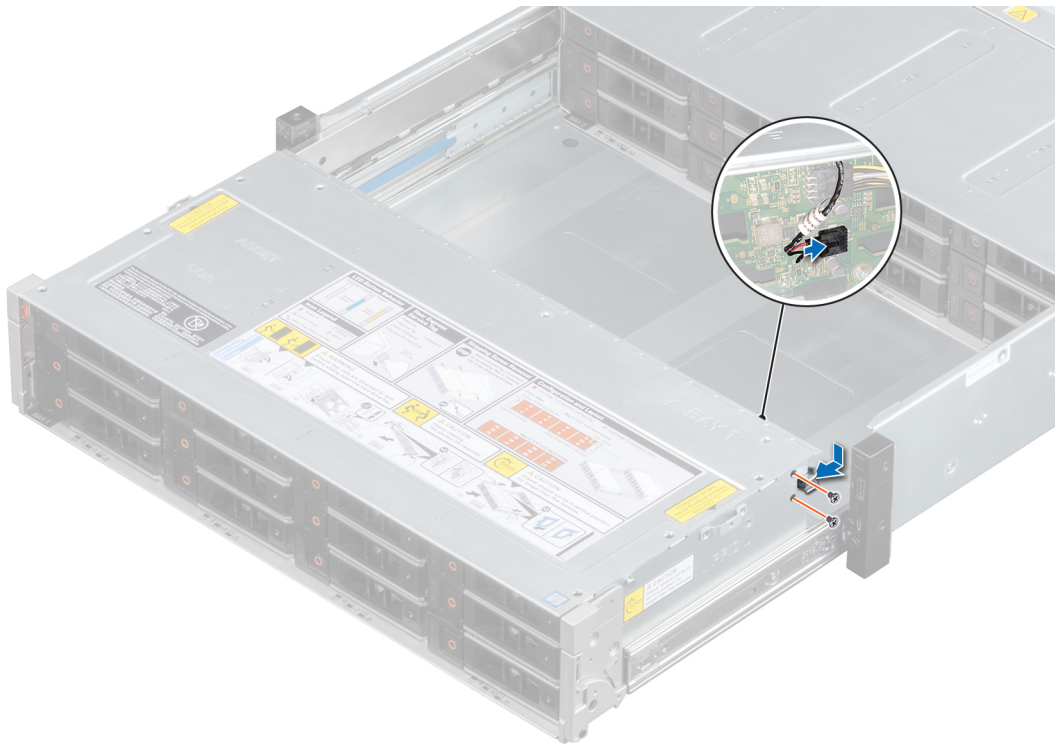

Figure 48. Installing the bay intrusion switch

Next steps

1. Install the drive bay 1 bracket.
2. Close the drive bays.
3. If removed, install the front bezel.
4. Follow the procedure listed in [After working inside your system](#).

Drive backplane

Drive backplane guidelines

Depending on your system configuration, the drive backplanes supported in XC740xd2 are listed here:

Table 3. Supported backplane options for XC740xd2 system

System	Supported backplane options
XC740xd2	3.5-inch (x12) SAS/SATA/SSD backplane (front)

NOTE: The backplane for both drive bay 1 and bay 2 is identical.

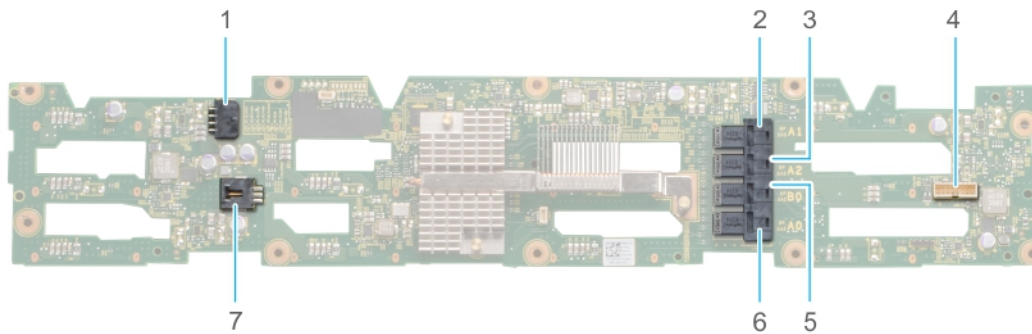

Figure 49. 12 x 3.5-inch drive backplane

- | | |
|---|---|
| 1. Power connector (J_BP_PWR1) | 2. SAS/SATA cable connector (BP SAS A1) |
| 3. SAS/SATA cable connector (BP SAS A2) | 4. Signal connector (J_BP_SIG1) |
| 5. SAS/SATA cable connector (BP SAS B0) | 6. SAS/SATA cable connector (BP SAS A0) |
| 7. Intrusion switch cable connector | |

Removing the drive bay 1 backplane

Prerequisites

CAUTION: To prevent damage to the drives and backplane, remove the drives from the system before removing the backplane.

CAUTION: Note the number of each drive and temporarily label them before you remove the drive so that you can replace them in the same location.

NOTE: Ensure that the drive bay is fully open to access the backplane.

1. Follow the safety guidelines listed in [Safety Instructions](#).
2. Follow the procedure listed in [Before working inside your system](#).
3. If installed, [remove the front bezel](#).
4. [Remove all the drives](#) from the drive slots from bay 1.
5. [Open the drive bays](#).
6. [Remove the drive bay 1 bracket](#).
7. [Remove the bay intrusion switch](#).
8. Disconnect all the cables from the backplane.

Steps

1. Using Phillips #2 screwdriver, remove all the screws securing the backplane.

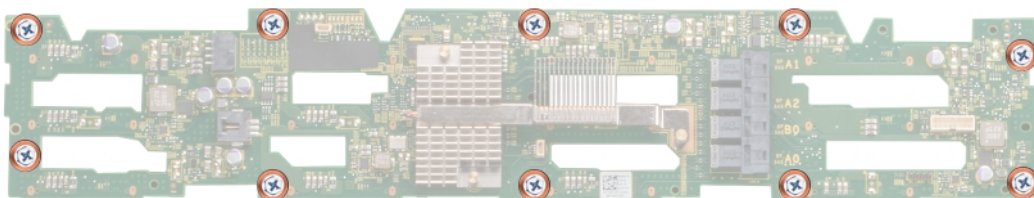

Figure 50. Removing the screws from the backplane

2. Hold the backplane by the edges and remove it from the bay.

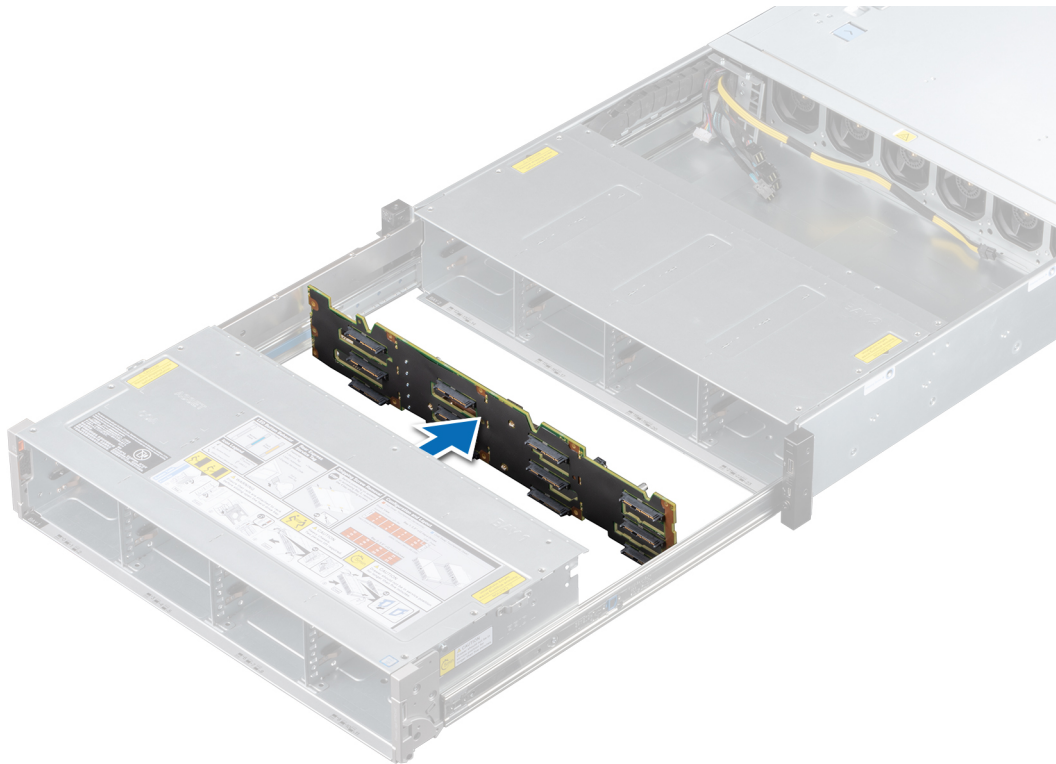

Figure 51. Removing bay 1 backplane

Next steps

Replace the drive bay 1 backplane.

Installing the drive bay 1 backplane

Prerequisites

Follow the safety guidelines listed in [Safety Instructions](#).

NOTE: The procedure to install the backplane is similar for all backplane configurations.

1. Follow the procedure listed in [Before working inside your system](#).
2. If installed, [remove the front bezel](#).
3. [Remove all the drives](#) from the drive slots from bay 1.
4. [Open the drive bays](#).
5. [Remove the drive bay 1 bracket](#).
6. [Remove the bay intrusion switch](#).
7. Disconnect all the cables from the backplane.

Steps

1. Align the backplane to the guiding pins on the bay.
2. Using Phillips #2 screwdriver, tighten all the screws to secure the backplane.

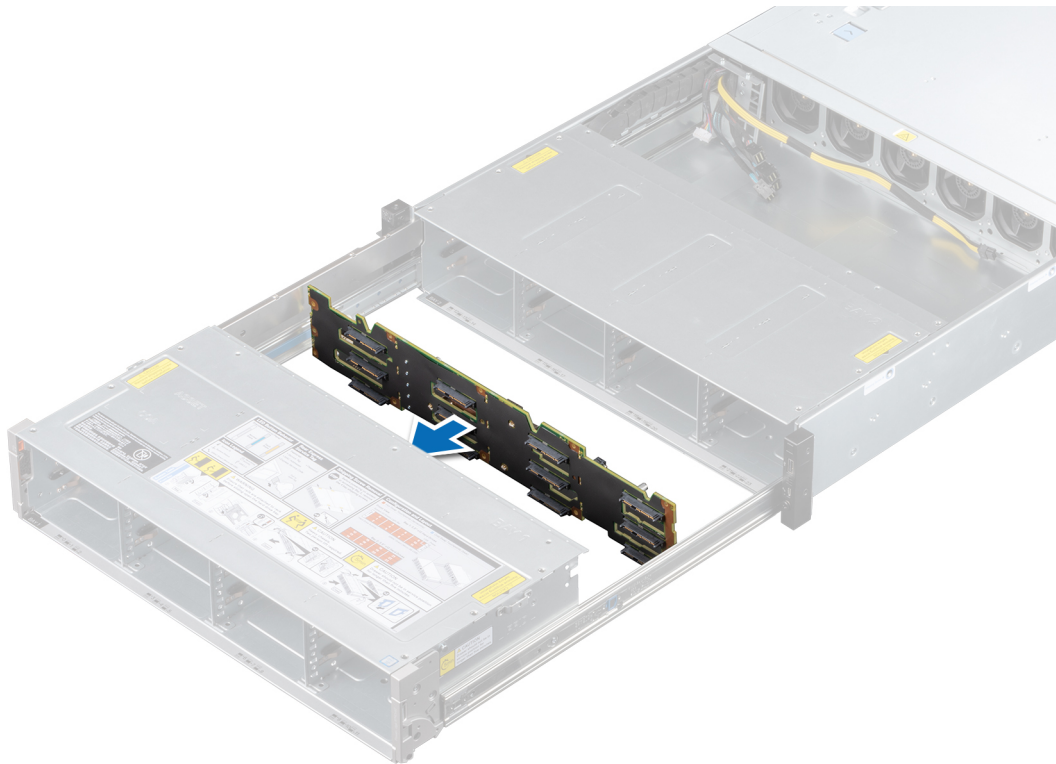

Figure 52. Installing bay 1 backplane

Next steps

1. [Install the bay intrusion switch.](#)
2. Connect all the cables to the backplane.
3. [Install the drive bay 1 bracket.](#)
4. Install the drives back into their original locations.
5. [Close the drive bays.](#)
6. If removed, [install the front bezel.](#)
7. Follow the procedure listed in [After working inside your system.](#)

Removing the drive bay 2 backplane

Prerequisites

CAUTION: Note the number of each drive and temporarily label them before you remove the drive so that you can replace them in the same location.

1. Follow the safety guidelines listed in [Safety Instructions.](#)
2. Power off the system and all attached peripherals.
3. Disconnect the system from the electrical outlet, and disconnect the peripherals.
4. [Open the drive bays](#), remove **all drives**, and then [close the drive bays.](#)
5. Remove the [power supply units.](#)
6. Remove the system from the rack and place it on an ESD work bench. For more information, see the *Rail Installation Guide* at www.dell.com/xcseriesmanuals.
7. [Open the drive bays.](#)
NOTE: Ensure that the drive bay is fully open to access the backplane.
8. Remove the drive bay 2 backplane brackets.
9. Disconnect all the cables from the backplane.

Steps

1. Using Phillips #2 screwdriver, remove all the screws securing the backplane.

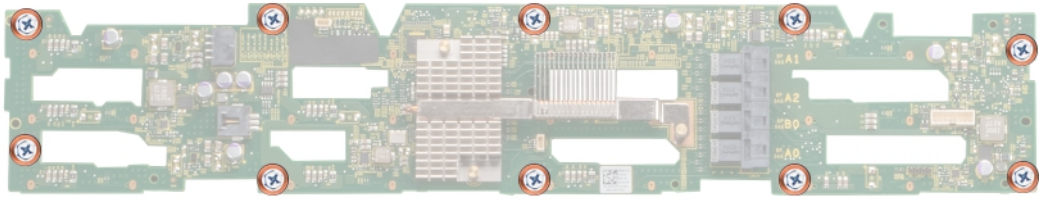

Figure 53. Removing the screws from the backplane

2. Hold the backplane by the edges and remove it from the bay.



Figure 54. Removing bay 2 backplane

Next steps

Replace the drive bay 2 backplane.

Installing the drive bay 2 backplane

Prerequisites

1. Follow the safety guidelines listed in [Safety Instructions](#).
2. Power off the system and all attached peripherals.
3. Disconnect the system from the electrical outlet, and disconnect the peripherals.
4. Ensure that all internal cables are routed correctly and connected, and no tools or extra parts are left inside the system.
5. If installed, [remove the front bezel](#).
6. [Open the drive bays](#), remove [all drives](#), and then [close the drive bays](#).
7. Remove the [power supply units](#).
8. Remove the system from the rack and place it on an ESD work bench. For more information, see the *Rail Installation Guide* at www.dell.com/xcseriesmanuals.
9. [Open the drive bays](#).

10. Remove the drive bay 2 backplane brackets.
11. Disconnect all the cables from the backplane.

Steps

1. Align the backplane to the guiding pins in the bay.
2. Using Phillips #2 screwdriver, tighten all the screws to secure the backplane.

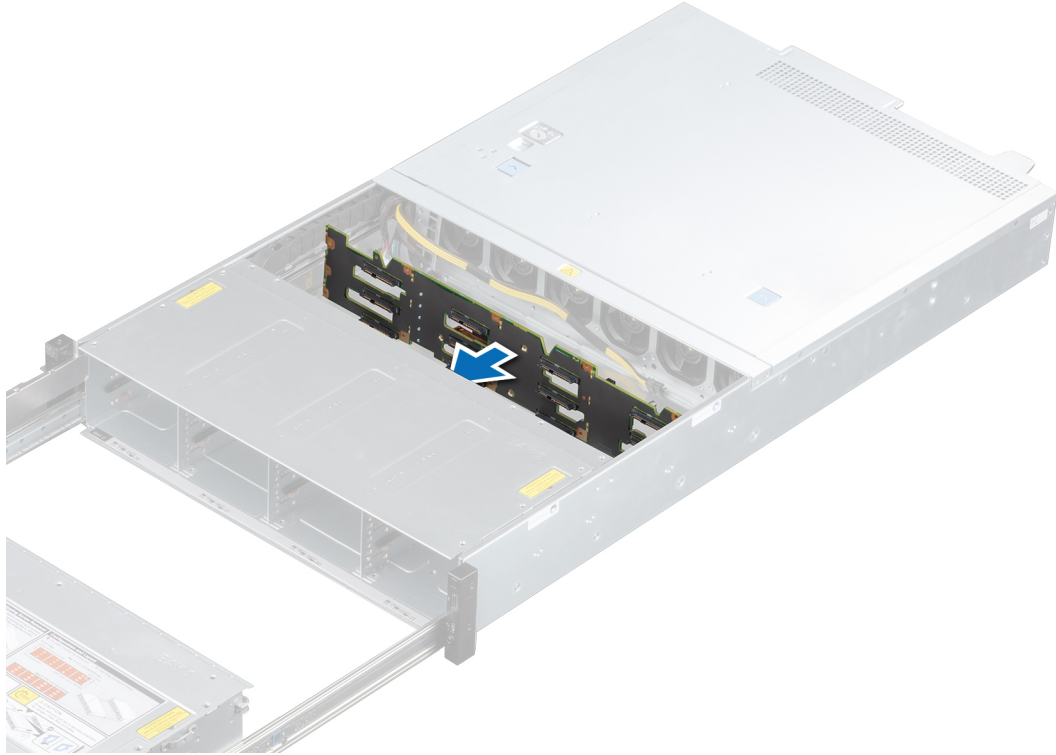

Figure 55. Installing bay 2 backplane

Next steps

1. Connect all the cables to the backplane.
2. [Install the drive bay 2 brackets.](#)
3. [Close the drive bays.](#)
4. Place the system into the rack. For more information, see the *Rail Installation Guide* at www.dell.com/xcseriesmanuals.
5. [Open the drive bays](#), install [all drives](#), and then [close the drive bays](#).
6. Install the [power supply units](#).
7. If removed, [install the front bezel](#).
8. Follow the procedure listed in [After working inside your system](#).

Cable routing

Table 4. Cable routing legend

Color	Description
Red	Power
Green	Signal
Grey	Data

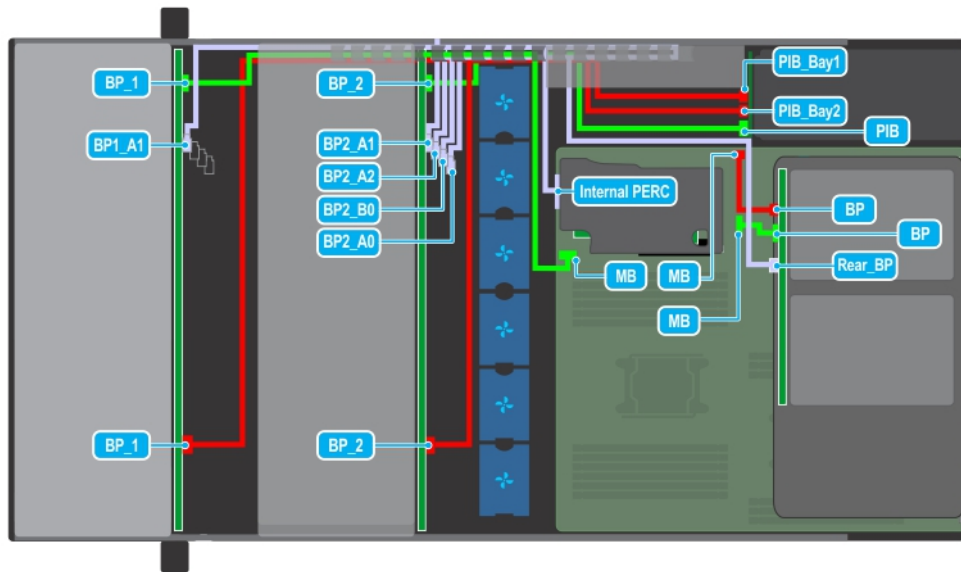

Figure 56. Cable routing - System with 2 x 3.5-inch rear drive backplane connected to cable chain assembly

System memory

System memory guidelines

The XC systems support DDR4 Registered DIMMs (RDIMMs). System memory holds the instructions that are executed by the processor.

Your system contains 16 memory sockets. Processor 1 supports up to 10 memory sockets and Processor 2 supports up to 6 memory sockets. Six memory channels are allocated to each processor. Processor 1 has four 2 DIMM slots per channel and two 1 DIMM slot per channel. Processor 2 has six 1 DIMM per channel.

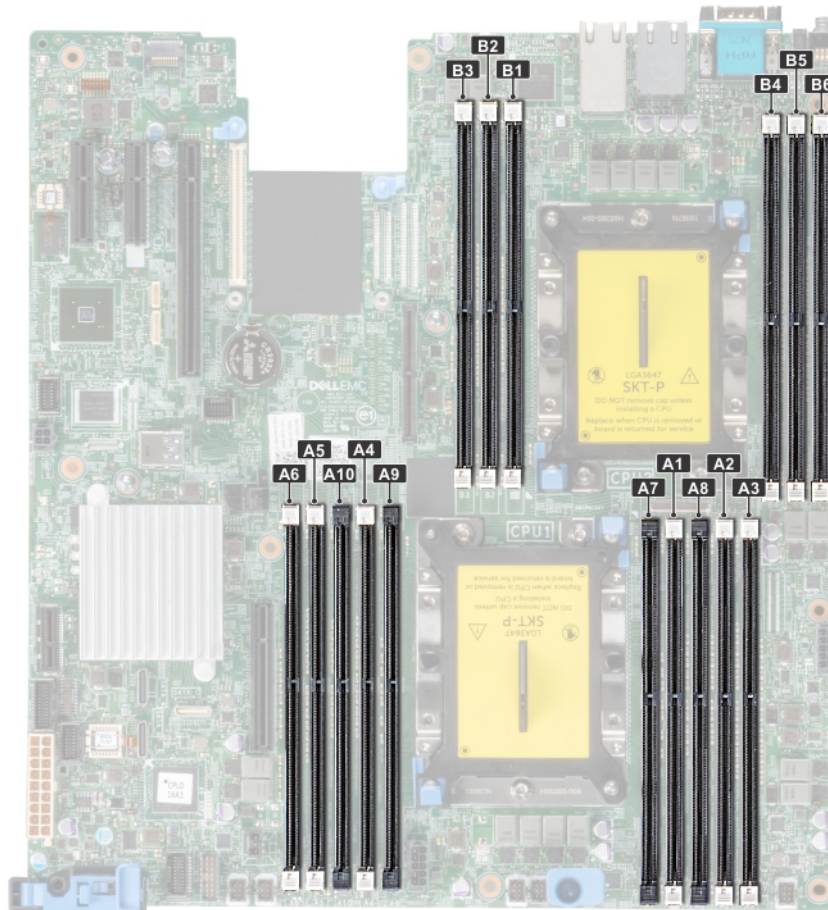

Figure 57. System memory

Memory channels are organized as follows:

Table 5. Memory channels

Processor	Channel 0	Channel 1	Channel 2	Channel 3	Channel 4	Channel 5
Processor 1	Slots A1 and A7	Slots A2 and A8	Slots A3	Slots A4 and A9	Slots A5 and A10	Slots A6
Processor 2	Slots B1	Slots B2	Slots B3	Slots B4	Slots B5	Slots B6

Table 6. Memory population

DIMM Type	DIMMs Populated/ Channel	Voltage	Operating Frequency (in MT/s)	Maximum DIMM Rank/ Channel
RDIMM	1	1.2 V	2933, 2666, 2400, 2133, 1866	Dual rank or single rank
	2		2933, 2666, 2400, 2133, 1866	Dual rank or single rank

General memory module installation guidelines

NOTE: If your system's memory configurations fail to observe these guidelines, your system might not boot, might stop responding during memory configuration, or might operate with reduced memory.

The system supports Flexible Memory Configuration, enabling the system to be configured and run in any valid chipset architectural configuration. The following are the recommended guidelines for installing memory modules:

- x4 and x8 DRAM based memory modules can be mixed. For more information, see the [Mode-specific guidelines](#) section.
- Up to two RDIMMs can be populated per channel regardless of rank count.

- If memory modules with different speeds are installed, they will operate at the speed of the slowest installed memory module(s) or slower depending on the system DIMM configuration.
- Populate memory module sockets only if a processor is installed. For single-processor systems, sockets A1 to A10 are available. For dual-processor systems, sockets A1 to A10 and sockets B1 to B6 are available.
- Populate all the sockets with white release tabs first, followed by the black release tabs.
- When mixing memory modules with different capacities, populate the sockets with memory modules with the highest capacity first. For example, if you want to mix 8 GB and 16 GB memory modules, populate 16 GB memory modules in the sockets with white release tabs and 8 GB memory modules in the sockets with black release tabs.
- In a dual-processor configuration, the memory configuration for each processor should be identical. For example, if you populate socket A1 for processor 1, then populate socket B1 for processor 2, and so on.
- Memory modules of different capacities can be mixed provided other memory population rules are followed (for example, 8 GB and 16 GB memory modules can be mixed).
- Mixing of more than two memory module capacities in a system is not supported.
- Populate six memory modules per processor (one DIMM per channel) at a time to maximize performance.

Mode-specific guidelines

The configurations allowed depend on the memory mode selected in the System BIOS.

Table 7. Memory operating modes

Memory Operating Mode	Description
Optimizer Mode (Default)	The Optimizer Mode if enabled, the DRAM controllers operate independently in the 64-bit mode and provide optimized memory performance.
Mirror Mode	The Mirror Mode if enabled, the system maintains two identical copies of data in memory, and the total available system memory is one half of the total installed physical memory. Half of the installed memory is used to mirror the active memory modules. This feature provides maximum reliability and enables the system to continue running even during a catastrophic memory failure by switching over to the mirrored copy. The installation guidelines to enable Mirror Mode require that the memory modules be identical in size, speed, and technology, and they must be populated in sets of 6 per processor.
Single Rank Spare Mode	Single Rank Spare Mode allocates one rank per channel as a spare. If excessive correctable errors occur in a rank or channel, while the operating system is running, they are moved to the spare area to prevent errors from causing an uncorrectable failure. Requires two or more ranks to be populated in each channel.
Multi Rank Spare Mode	Multi Rank Spare Mode allocates two ranks per channel as a spare. If excessive correctable errors occur in a rank or channel, while the operating system is running, they are moved to the spare area to prevent errors from causing an uncorrectable failure. Requires three or more ranks to be populated in each channel. With single rank memory sparing enabled, the system memory available to the operating system is reduced by one rank per channel. For example, in a dual-processor configuration with sixteen 16 GB dual-rank memory modules, the available system memory: $16 \text{ GB} \times 16(\text{memory modules}) - 8\text{GB}(1 \text{ rank sparing/channel}) \times 12(\text{channel}) = 256 \text{ GB} - 96 \text{ GB} = 160 \text{ GB}$ For multi rank sparing, in a dual-processor configuration with sixteen 64 GB quad-rank memory modules, the available system memory: $64 \text{ GB} \times 16(\text{memory modules}) - 32 \text{ GB}(2 \text{ rank sparing/channel}) \times 12 (\text{channel}) = 1024 \text{ GB} - 384 \text{ GB} = 640 \text{ GB}$

NOTE: To use memory sparing, this feature must be enabled in the BIOS menu of System Setup.

Memory Operating Mode

Description

NOTE: Memory sparing does not offer protection against a multi-bit uncorrectable error.

Optimizer Mode

This mode supports Single Device Data Correction (SDDC) only for memory modules that use x4 device width. It does not impose any specific slot population requirements.

- Dual processor: Populate the slots in round robin sequence starting with processor 1.

NOTE: Processor 1 and processor 2 population should match.

Table 8. Memory population rules

Processor	Configuration	Memory population	Memory population information
Single processor	Optimizer (Independent channel) population order	1, 2, 3, 4, 5, 6, 7, 8, 9, 10	<ul style="list-style-type: none">• Populate in this order, odd amount allowed.• Odd number of DIMM population is allowed. <p>NOTE: Odd number of DIMMs will result in unbalanced memory configurations, which in turn will result in performance loss. It is recommended to populate all memory channels identically with identical DIMMs for best performance.</p> <ul style="list-style-type: none">• Optimizer population order is not traditional for 4 and 8 DIMM installations of single processor.<ul style="list-style-type: none">• For 4 DIMMs: A1, A2, A4, A5• For 8 DIMMs: A1, A2, A4, A5, A7, A8, A9, A10
	Mirror population order	{1, 2, 3, 4, 5, 6}	Mirroring is supported with 6 DIMM slots per processor.
	Single rank sparing population order	1, 2, 3, 4, 5, 6, 7, 8, 9, 10	Populate in this order, odd amount allowed. Requires two ranks or more per channel.
	Multi rank sparing population order	1, 2, 3, 4, 5, 6, 7, 8, 9, 10	Populate in this order, odd amount allowed. Requires three ranks or more per channel.
Dual processor (Populate round robin starting with processor1)	Optimized (Independent channel) population order	A{1}, B{1}, A{2}, B{2}, A{3}, B{3}...	<ul style="list-style-type: none">• Odd amount of DIMM slots per processor allowed.• Odd number of DIMM population is allowed. <p>NOTE: Odd number of DIMMs will result in unbalanced memory configurations, which in turn will result in performance loss. It is recommended to populate all memory channels</p>

Processor	Configuration	Memory population	Memory population information
			<p>identically with identical DIMMs for best performance.</p> <ul style="list-style-type: none"> Optimizer population order is not traditional for 8 and 14 DIMM installations of dual processor. <ul style="list-style-type: none"> For 8 DIMMs: A1, A2, A4, A5, B1, B2, B4, B5 For 14 DIMMs: A1, A2, A4, A5, A7, A8, A9, A10, B1, B2, B3, B4, B5, B6
	Mirroring population order	A{1, 2, 3, 4, 5, 6}, B{1, 2, 3, 4, 5, 6}	Mirroring is supported with 6 DIMM slots per processor.
	Single rank sparing population order	A{1}, B{1}, A{2}, B{2}, A{3}, B{3}...	Populate in this order, odd amount per processor allowed. Requires two ranks or more per channel.
	Multi rank sparing population order	A{1}, B{1}, A{2}, B{2}, A{3}, B{3}...	Populate in this order, odd amount per processor allowed. Requires three ranks or more per channel.

Removing a memory module

Prerequisites

- Follow the safety guidelines listed in [Safety Instructions](#).
- Power off the system and all attached peripherals.
- Disconnect the system from the electrical outlet, and disconnect the peripherals.
- [Open the drive bays](#), remove **all drives**, and then [close the drive bays](#).
- Remove the [power supply units](#).
- Remove the system from the rack and place it on an ESD work bench. For more information, see the *Rail Installation Guide* at www.dell.com/xcseriesmanuals.
- [Remove the system cover](#).
- [Remove the air shroud](#).

Locate the appropriate memory module socket.

WARNING: Allow the memory modules to cool after you power off the system. Handle the memory modules by the card edges and avoid touching the components or metallic contacts on the memory module.

Steps

- Push the ejectors outward on both ends of the memory module socket to release the memory module from the socket.
- Lift and remove the memory module from the system.

CAUTION: Handle memory modules only by the card edges, ensuring not to touch the middle of the memory module or metallic contacts.

NOTE: If you are removing the memory module permanently, install a memory module blank. The procedure to install a memory module blank is similar to that of the memory module.

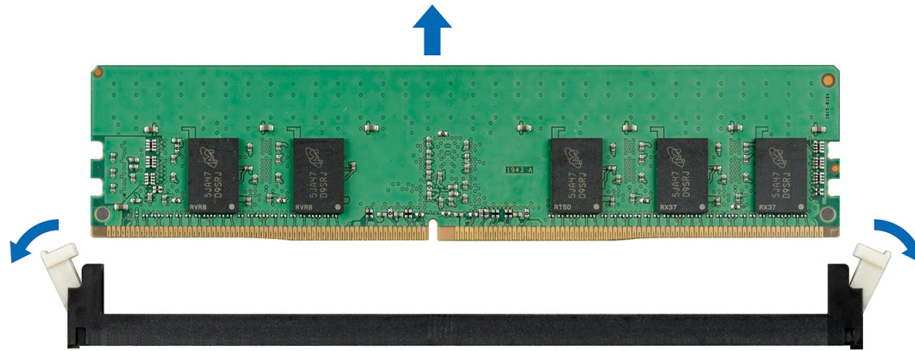

Figure 58. Removing a memory module

Installing a memory module

Prerequisites

1. Follow the safety guidelines listed in [Safety Instructions](#).
2. Power off the system and all attached peripherals.
3. Disconnect the system from the electrical outlet, and disconnect the peripherals.
4. Ensure that all internal cables are routed correctly and connected, and no tools or extra parts are left inside the system.
5. [Open the drive bays](#), remove [all drives](#), and then [close the drive bays](#).
6. Remove the [power supply units](#).
7. Remove the system from the rack and place it on an ESD work bench. For more information, see the *Rail Installation Guide* at www.dell.com/xcseriesmanuals.
8. [Remove the system cover](#).
9. [Remove the air shroud](#).

Locate the appropriate memory module socket.

NOTE: The procedure to remove a memory module blank is similar to the procedure to remove a memory module. Retain the removed memory module blank for future use.

Steps

1. Open the ejectors on the memory module socket outward to allow the memory module to be inserted into the socket.
2. Align the edge connector of the memory module with the alignment key of the memory module socket, and insert the memory module in the socket.

CAUTION: Handle each memory module only by the card edges, ensuring not to touch the middle of the memory module or metallic contacts.

NOTE: The memory module socket has an alignment notch that enables you to install the memory module in the socket in only one orientation.

3. Press the memory module with your thumbs until the ejectors firmly click into place.

CAUTION: To prevent damage to the memory module or the memory module socket during installation, do not bend or flex the memory module. You must insert both ends of the memory module simultaneously.

CAUTION: Do not apply pressure at the center of the memory module; apply pressure at both ends of the memory module evenly.

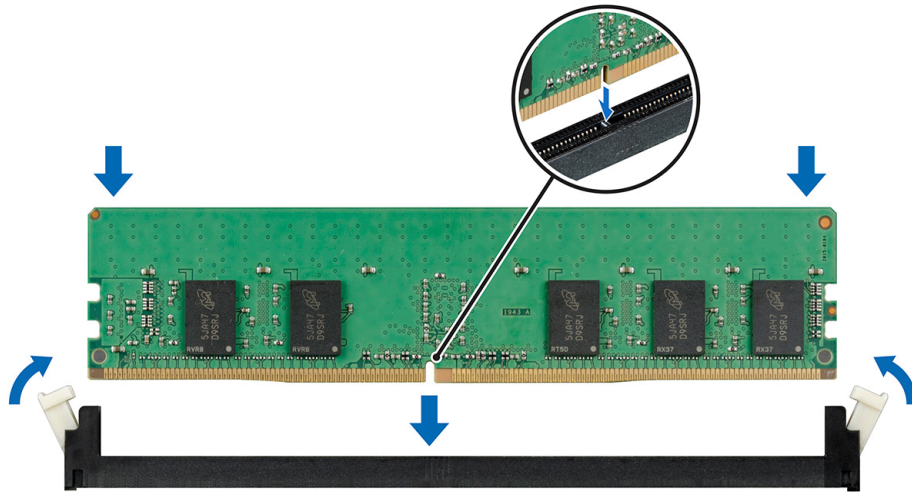

Figure 59. Installing a memory module

Next steps

1. Install the air shroud.
2. Install the system cover.
3. Place the system into the rack. For more information, see the *Rail Installation Guide* at www.dell.com/xcseriesmanuals.
4. Open the drive bays, install all drives, and then close the drive bays.
5. Install the power supply units.
6. Follow the procedure listed in *After working inside your system*.
7. To verify if the memory module has been installed properly, press F2 and navigate to **System Setup Main Menu > System BIOS > Memory Settings**. In the **Memory Settings** screen, the System Memory Size must reflect the updated capacity of the installed memory.
8. If the value is incorrect, one or more of the memory modules may not be installed properly. Ensure that the memory module is firmly seated in the memory module socket.
9. Run the system memory test in system diagnostics.

Processor and heat sink

Removing a processor and heat sink module

Prerequisites

⚠ WARNING: The heat sink may remain hot to touch for some time after the system is powered down. Allow the heat sink to cool before removing it.

1. Follow the safety guidelines listed in *Safety Instructions*.
2. Power off the system and all attached peripherals.
3. Disconnect the system from the electrical outlet, and disconnect the peripherals.
4. Open the drive bays, remove all drives, and then close the drive bays.
5. Remove the power supply units.
6. Remove the system from the rack and place it on an ESD work bench. For more information, see the *Rail Installation Guide* at www.dell.com/xcseriesmanuals.
7. Remove the system cover.
8. Remove the air shroud.
9. If installed, remove the risers.

Steps

1. Using a Torx #T30 screwdriver, loosen the screws on the heat sink in the order below:
 - a) Loosen the first screw three turns.

- b) Loosen the second screw completely.
- c) Return to the first screw and loosen it completely.
2. Pushing both blue retention clips simultaneously, lift the processor and heat sink module (PHM) processor and heat sink module.
3. Set the PHM aside with the processor side facing up.

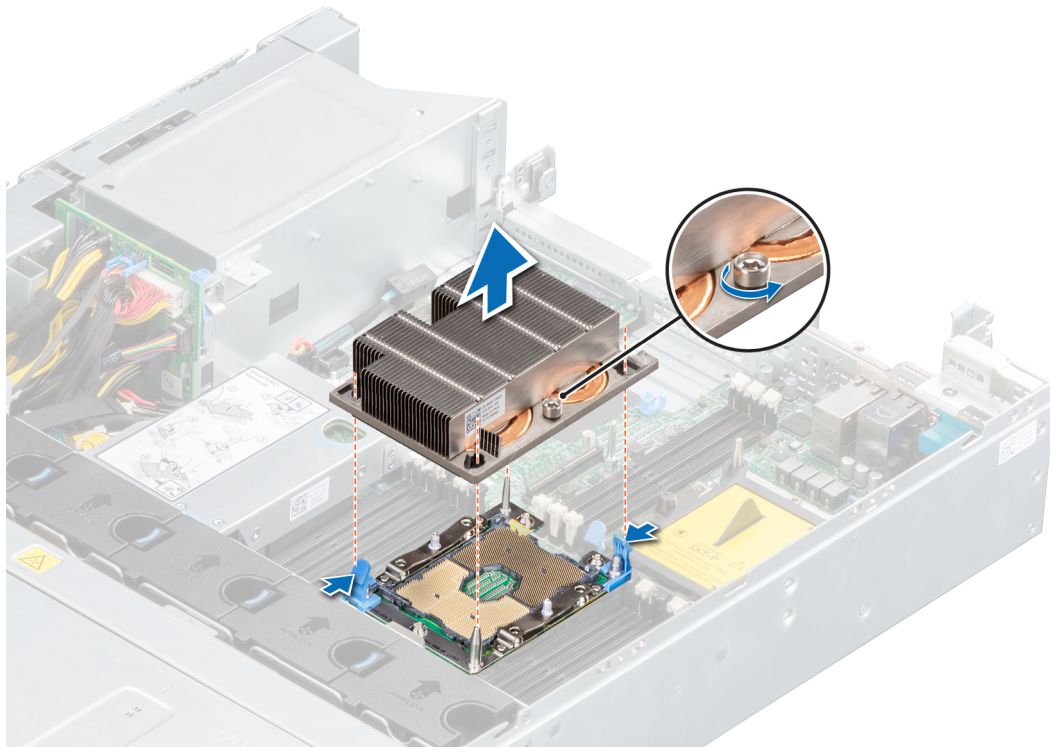

Figure 60. Removing a processor and heat sink module

Next steps

Replace a processor and heat sink module.

Removing the processor

Prerequisites

NOTE: Only remove the processor from the processor and heat sink module if you are replacing the processor or heat sink. This procedure is not required when replacing a system board.

1. Follow the safety guidelines listed in [Safety Instructions](#).
2. Power off the system and all attached peripherals.
3. Disconnect the system from the electrical outlet, and disconnect the peripherals.
4. [Open the drive bays](#), remove **all drives**, and then [close the drive bays](#).
5. Remove the [power supply units](#).
6. Remove the system from the rack and place it on an ESD work bench. For more information, see the *Rail Installation Guide* at www.dell.com/xcseriesmanuals.
7. [Remove the system cover](#).
8. [Remove the air shroud](#).
9. If installed, [remove the risers](#).
10. [Remove a processor and heat sink module](#).

Steps

1. Place the heat sink with the processor side facing up.
2. Insert a flat blade screwdriver into the release slot marked with a yellow label. Twist (do not pry) the screwdriver to break the thermal grease seal.

3. Push the retaining clips on the processor bracket to release the bracket from the heat sink.

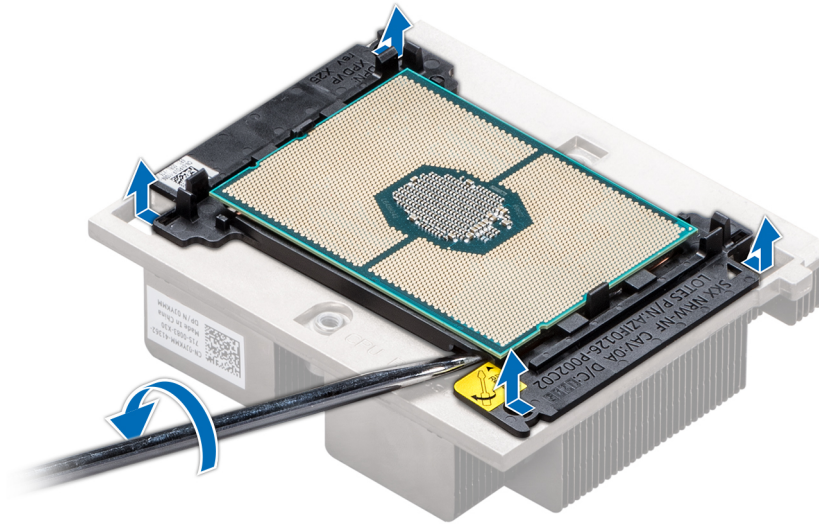

Figure 61. Loosening the processor bracket

4. Lift the processor bracket away from the heat sink, and place the processor connector side down on the processor tray.
5. Flex the outer edges of the bracket to release the bracket from the processor.

NOTE: Ensure that the processor bracket is placed in the tray after you remove it from the heat sink.



Figure 62. Removing the processor bracket

Next steps

Replace the processor into a processor and heat sink module.

Installing the processor

Prerequisites

1. Follow the safety guidelines listed in [Safety Instructions](#).
2. Power off the system and all attached peripherals.
3. Disconnect the system from the electrical outlet, and disconnect the peripherals.
4. Ensure that all internal cables are routed correctly and connected, and no tools or extra parts are left inside the system.
5. [Open the drive bays](#), remove **all drives**, and then [close the drive bays](#).

6. Remove the [power supply units](#).
7. Remove the system from the rack and place it on an ESD work bench. For more information, see the *Rail Installation Guide* at www.dell.com/xcseriesmanuals.
8. [Remove the system cover](#).
9. [Remove the air shroud](#).
10. If installed, [remove the risers](#).
11. [Remove a processor and heat sink module](#)

Steps

1. Place the processor in the processor tray with the connector side facing down.
 - i** **NOTE:** Ensure that the pin 1 indicator on the processor tray is aligned with the pin 1 indicator on the processor.
2. Flex the outer edges of the bracket around the processor ensuring that the processor is locked into the clips on the bracket.
 - i** **NOTE:** Ensure that the pin 1 indicator on the bracket is aligned with the pin 1 indicator on the processor before placing the bracket on the processor.
 - i** **NOTE:** Ensure that the processor and the bracket are placed in the tray before you install the heat sink.



Figure 63. Installing the processor bracket

3. If you are using an existing heat sink, remove the thermal grease from the heat sink by using a clean lint-free cloth.
4. Use the thermal grease syringe included with your processor kit to apply the grease in a quadrilateral design on the top of the processor.
 - ⚠ CAUTION:** Applying too much thermal grease can result in excess grease coming in contact with and contaminating the processor socket.
 - i** **NOTE:** The thermal grease syringe is intended for single use only. Dispose the syringe after you use it.

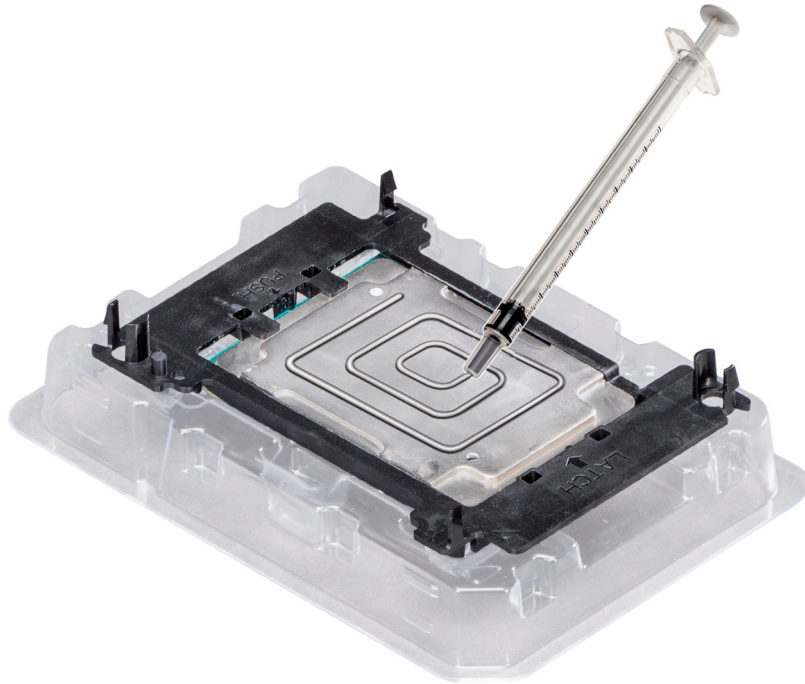

Figure 64. Applying thermal grease on top of the processor

5. Place the heat sink on the processor and push down on the base of the heat sink until the bracket locks onto the heat sink.

NOTE:

- Ensure that the two guide pin holes on the bracket match the guide holes on the heat sink.
- Do not press on the heat sink fins.
- Ensure that the pin 1 indicator on the heat sink is aligned with the pin 1 indicator on the bracket before placing the heat sink onto the processor bracket.

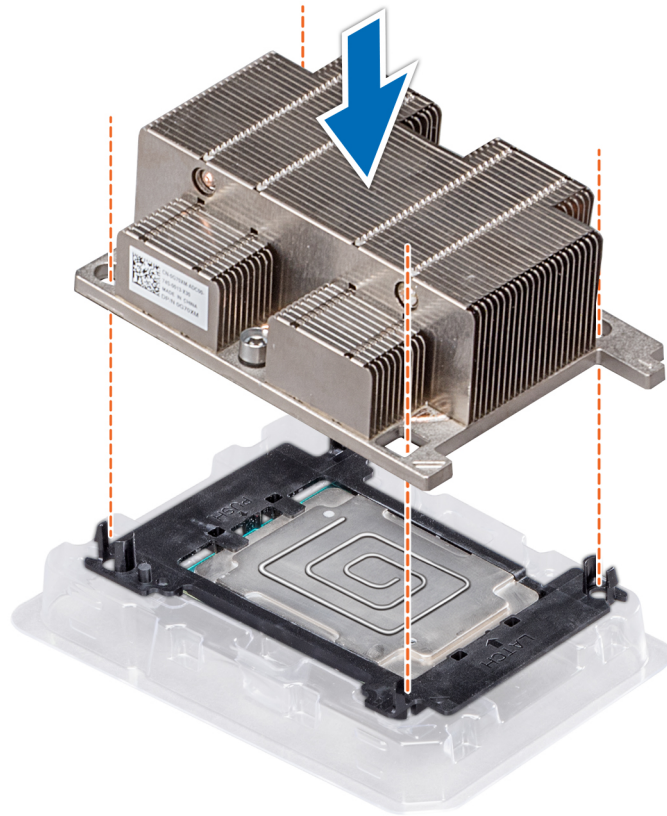

Figure 65. Installing the heat sink onto the processor

Next steps

1. [Install the processor and heatsink.](#)
2. If removed, [install the risers.](#)
- 3.
4. [Install the air shroud.](#)
5. Install the [system cover.](#)
6. Place the system into the rack. For more information, see the *Rail Installation Guide* at www.dell.com/xcseriesmanuals.
7. [Open the drive bays](#), install [all drives](#), and then [close the drive bays](#).
8. Install the [power supply units.](#)
9. Follow the procedure listed in [After working inside your system.](#)

Installing a processor and heat sink module

Prerequisites

CAUTION: Never remove the heat sink from a processor unless you intend to replace the processor. The heat sink is necessary to maintain proper thermal conditions.

1. Follow the safety guidelines listed in [Safety Instructions](#).
2. Power off the system and all attached peripherals.
3. Disconnect the system from the electrical outlet, and disconnect the peripherals.
4. Ensure that all internal cables are routed correctly and connected, and no tools or extra parts are left inside the system.
5. [Open the drive bays](#), remove [all drives](#), and then [close the drive bays](#).
6. Remove the [power supply units](#).
7. Remove the system from the rack and place it on an ESD work bench. For more information, see the *Rail Installation Guide* at www.dell.com/xcseriesmanuals.
8. [Remove the system cover.](#)

9. Remove the air shroud.
10. If installed, remove the risers.
11. If installed, remove the processor dust cover.

Steps

1. Align the pin 1 indicator of the heat sink to the system board and then place the processor and heat sink module (PHM) on the processor socket.

CAUTION: To avoid damaging the fins on the heat sink, do not press down on the heat sink fins.

NOTE: Ensure that the PHM is held parallel to the system board to prevent damaging the components.

2. Push the blue retention clips inward to allow the heat sink to be lowered into place.
3. Using the Torx #T30 screwdriver, tighten the screws on the heat sink in the order below:
 - a) Partially tighten the first screw (approximately 3 turns).
 - b) Tighten the second screw completely.
 - c) Return to the first screw and tighten it completely.

If the PHM slips off the blue retention clips when the screws are partially tightened, follow these steps to secure the PHM:

- a. Loosen both the heat sink screws completely.
- b. Lower the PHM on to the blue retention clips, following the procedure described in step 2.
- c. Secure the PHM to the system board, following the replacement instructions listed in step 3.

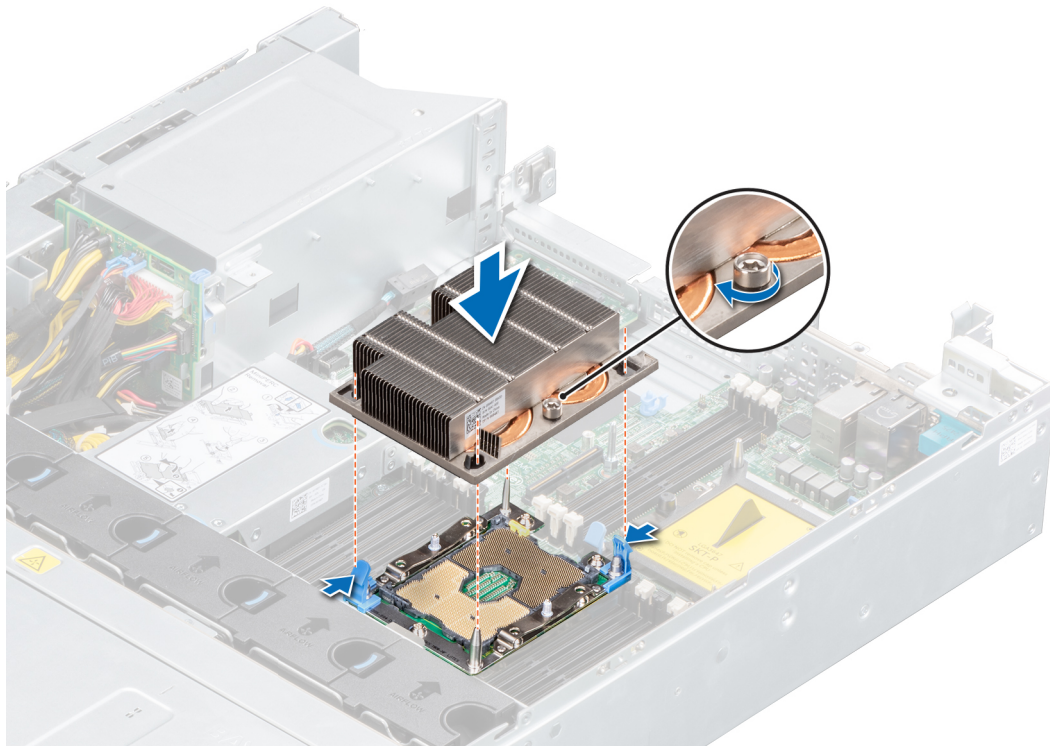

Figure 66. Installing the processor and heat sink module

Next steps

1. If removed, install the risers.
- 2.
3. Install the air shroud.
4. Install the system cover.
5. Place the system into the rack. For more information, see the *Rail Installation Guide* at www.dell.com/xcseriesmanuals.
6. Open the drive bays, install all drives, and then close the drive bays.
7. Install the power supply units.
8. Follow the procedure listed in *After working inside your system*.

Expansion cards and expansion card risers

NOTE: A System Event Log (SEL) event is logged if an expansion card riser is not supported or missing. It does not prevent your system from turning on. However, if a F1/F2 pause occurs with an error message, see *Troubleshooting expansion cards* section in the *Dell EMC XC Systems Troubleshooting Guide* at www.dell.com/xcseriesmanuals.

Expansion card installation guidelines

The following table provides guidelines for installing expansion cards to ensure proper cooling and mechanical fit. The expansion cards with the highest priority should be installed first using the slot priority indicated. All the other expansion cards should be installed in the card priority and slot priority order.

Table 9. Riser configurations: Butterfly riser + 3 x low profile - Processor 1 and 2

Card type	Slot priority	Maximum number of cards
BOSS M.2 (SATA) (Dell)	2	1
Low Profile LP card 10G and 25G (Intel/Mellanox)	6, 5, 4	3
HBA330 (Internal)	Integrated Slot	1

Removing expansion card from the system board

Prerequisites

1. Follow the safety guidelines listed in [Safety Instructions](#).
2. Power off the system and all attached peripherals.
3. Disconnect the system from the electrical outlet, and disconnect the peripherals.
4. Ensure that all internal cables are routed correctly and connected, and no tools or extra parts are left inside the system.
5. [Open the drive bays](#), remove [all drives](#), and then [close the drive bays](#).
6. Remove the [power supply units](#).
7. Remove the system from the rack and place it on an ESD work bench. For more information, see the *Rail Installation Guide* at www.dell.com/xcseriesmanuals.
8. [Remove the system cover](#).
9. [Remove the air shroud](#).
10. If installed, [remove the expansion card risers](#)
11. If applicable, disconnect any cables connected to the expansion card.

Steps

1. Press and lift up the expansion card retention latch to open.
2. Hold the expansion card by the edges and lift the card to disconnect it from the system board connector.

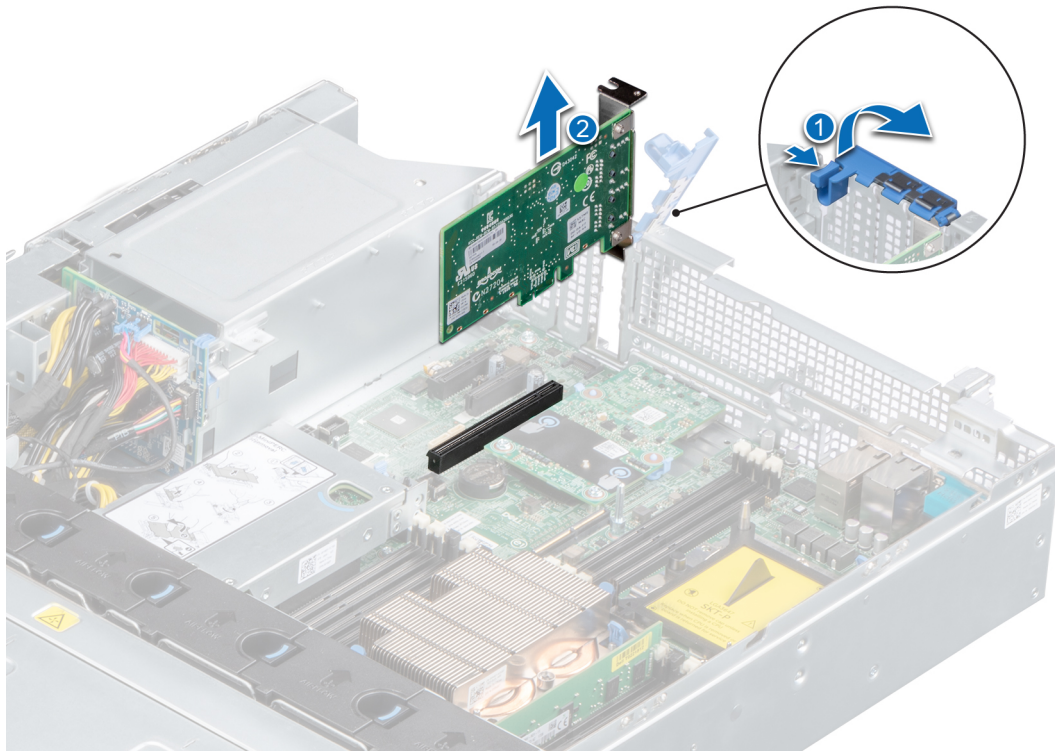

Figure 67. Removing expansion card from system board

3. If the expansion card is not going to be replaced, install a filler bracket by performing the following steps:
 - a) Align the filler bracket with the slot on the system.
 - b) Push the filler bracket downward until firmly seated.
 - c) Close the retention latch by pressing the latch down until the latch snaps into place.

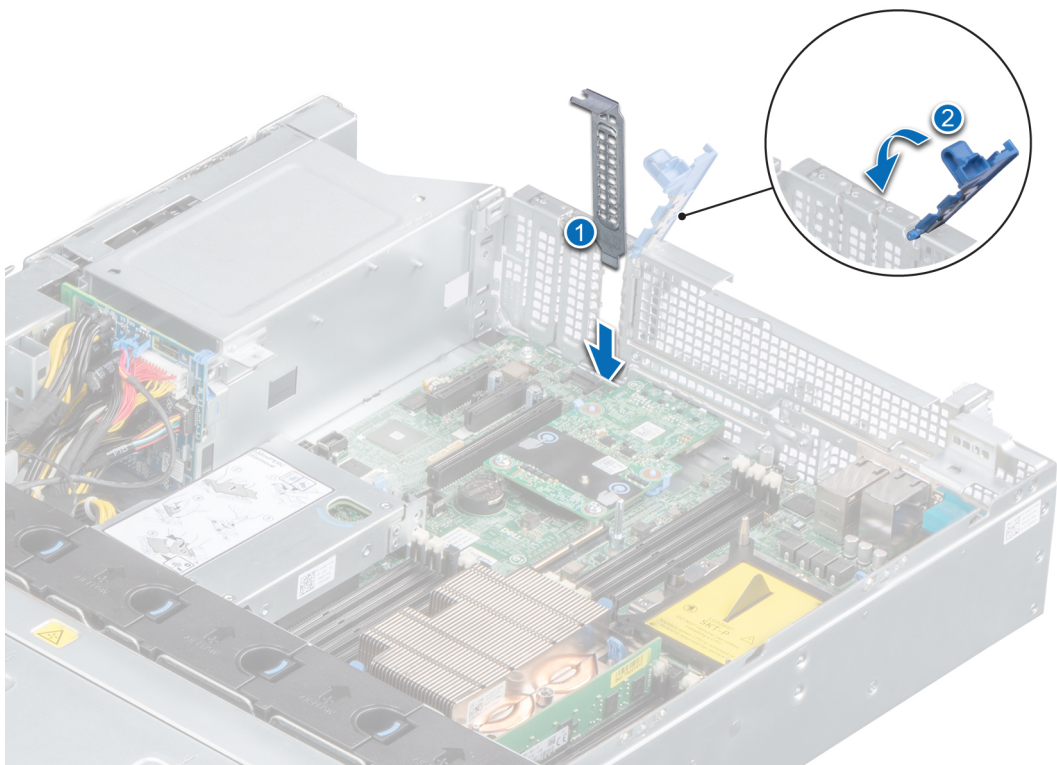

Figure 68. Installing the filler bracket

NOTE: Filler brackets must be installed over empty expansion card slots to maintain FCC certification of the system. The brackets also keep dust out of the system and aid in proper cooling and airflow inside the system.

Next steps

1. [Replace the expansion card on the system board.](#)

Removing expansion card from the expansion card riser

Prerequisites

1. Follow the safety guidelines listed in [Safety Instructions](#).
2. Power off the system and all attached peripherals.
3. Disconnect the system from the electrical outlet, and disconnect the peripherals.
4. [Open the drive bays](#), remove [all drives](#), and then [close the drive bays](#).
5. Remove the [power supply units](#).
6. Remove the system from the rack and place it on an ESD work bench. For more information, see the *Rail Installation Guide* at www.dell.com/xcseriesmanuals.
7. [Remove the system cover](#).
8. [Remove the air shroud](#).
9. [Remove the expansion card riser from the system](#).
10. When removing a card from low profile, full height X1, or butterfly riser, ensure that the PCIe card holder latch is closed.

Steps

1. Open the expansion card retention latch.
2. Hold the expansion card by its edges, and pull the card away from the expansion card connector on the riser.

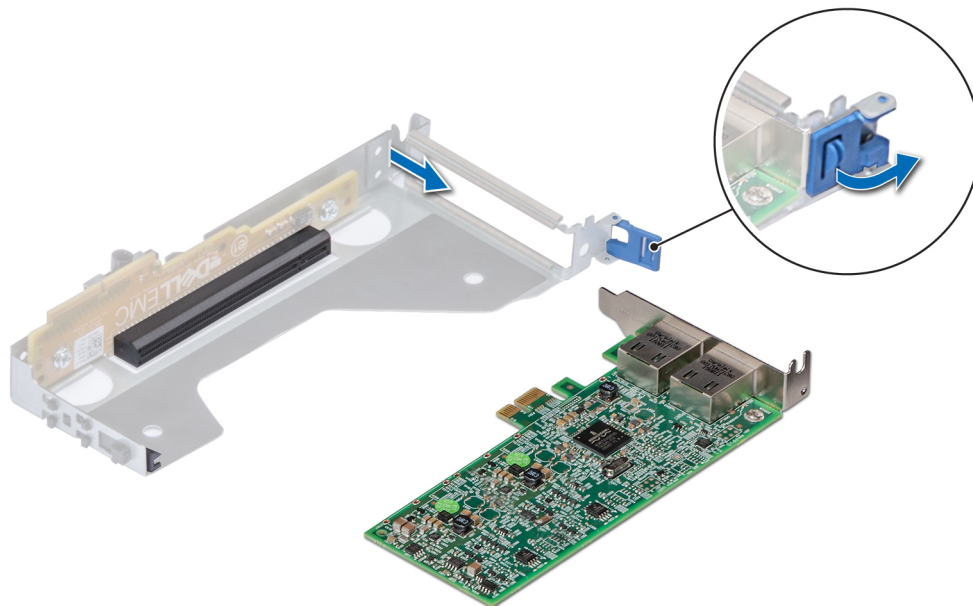

Figure 69. Removing expansion card from low profile riser

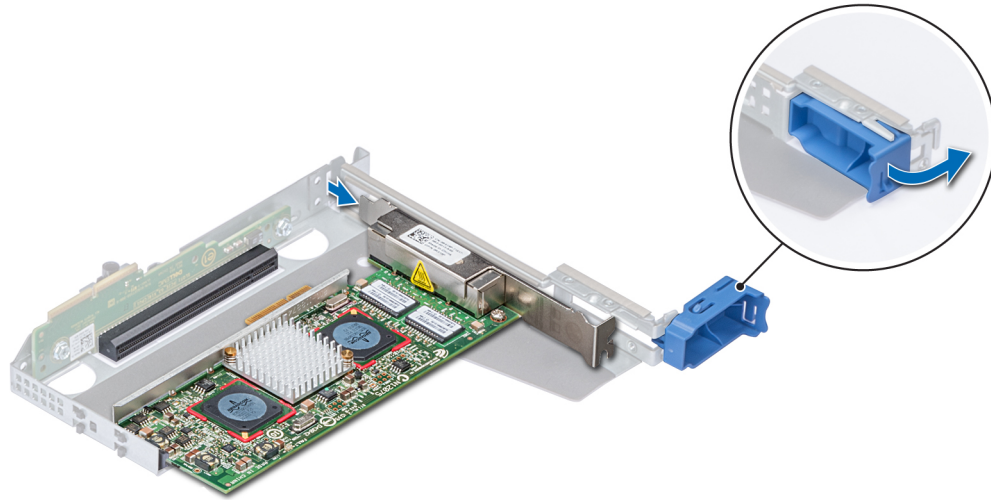

Figure 70. Removing expansion card from full height X1 riser

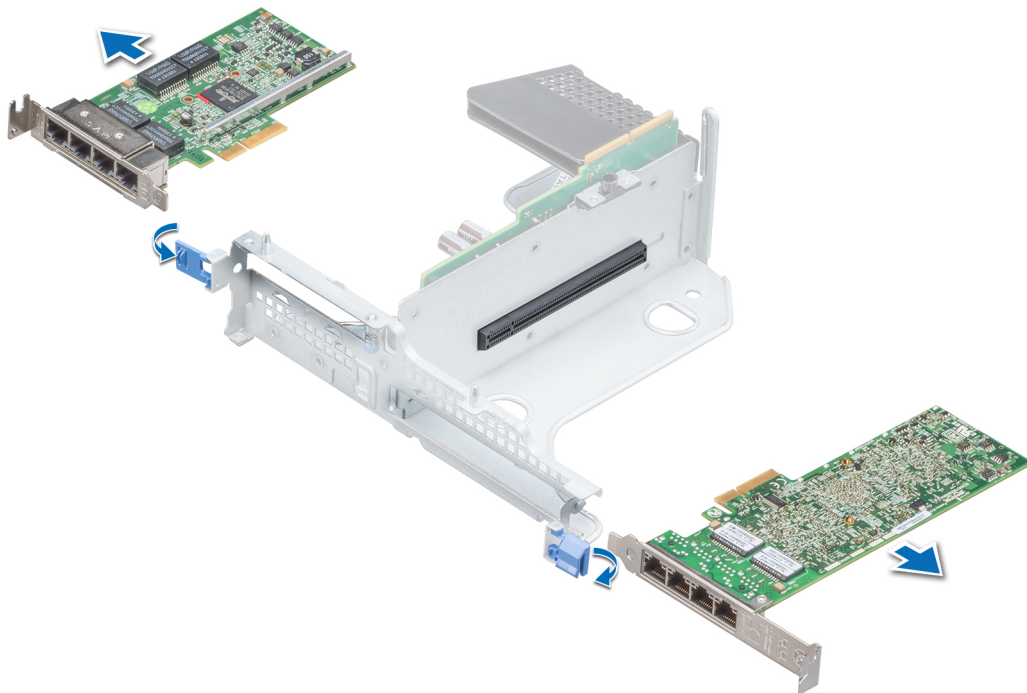

Figure 71. Removing expansion card from butterfly riser

3. If the expansion card is not going to be replaced, install a filler bracket.

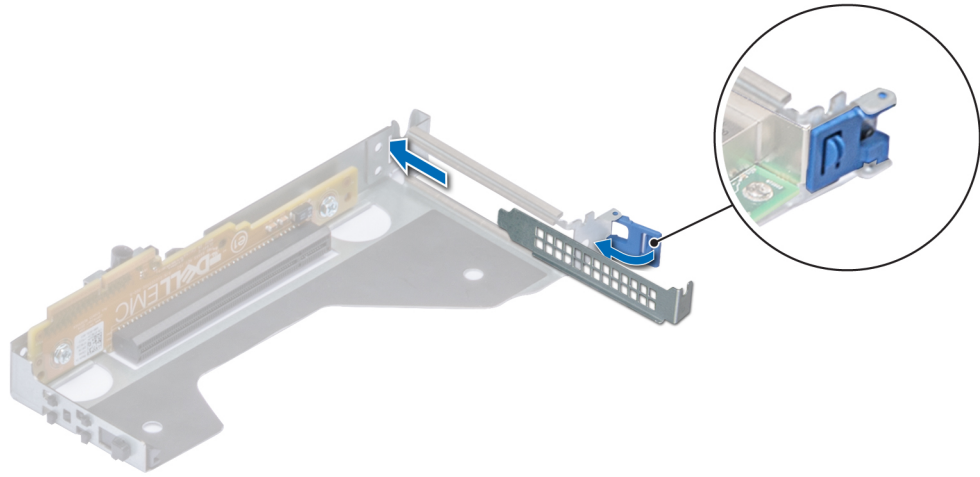

Figure 72. Installing filler bracket for low profile riser

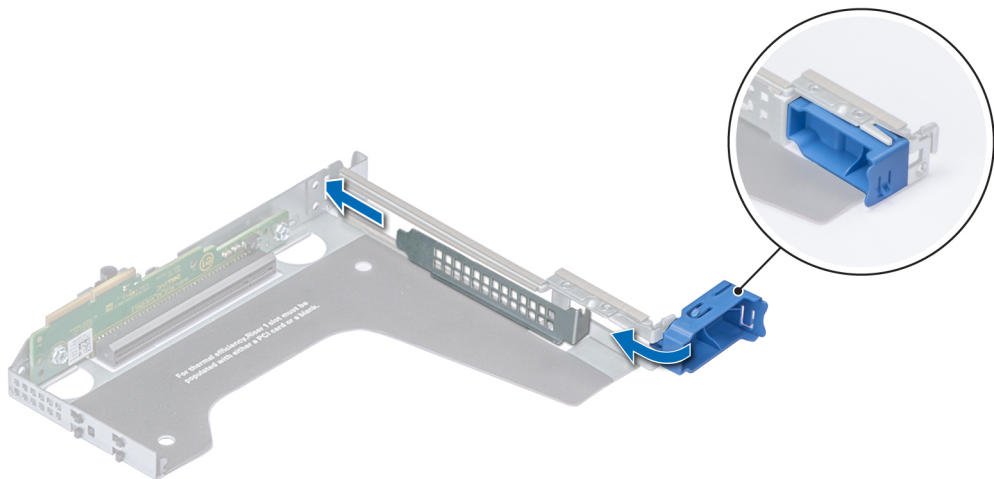

Figure 73. Installing filler bracket for full height X1 riser

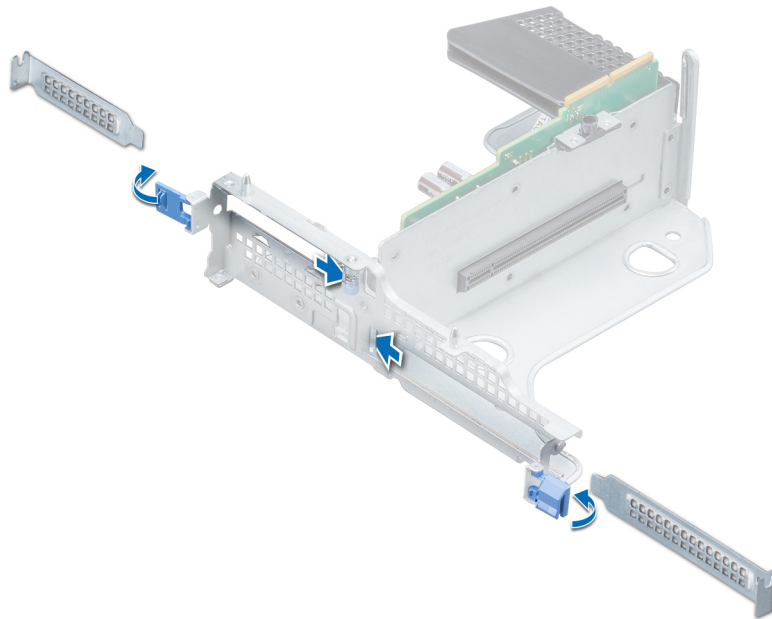

Figure 74. Installing filler bracket for butterfly riser

Next steps

1. [Replace expansion card into the expansion card riser.](#)
2. If you are removing the card permanently, install a metal filler bracket over the empty expansion slot opening and push the expansion card latch.

NOTE: You must install a filler bracket over an empty expansion card slot to maintain Federal Communications Commission (FCC) certification of the system. The brackets also keep dust out of the system and aid in proper cooling and airflow inside the system.

Installing expansion card into the expansion card riser

Prerequisites

1. Follow the safety guidelines listed in [Safety Instructions](#).
2. Power off the system and all attached peripherals.
3. Disconnect the system from the electrical outlet, and disconnect the peripherals.
4. Ensure that all internal cables are routed correctly and connected, and no tools or extra parts are left inside the system.
5. [Open the drive bays](#), remove **all drives**, and then [close the drive bays](#).
6. Remove the [power supply units](#).
7. Remove the system from the rack and place it on an ESD work bench. For more information, see the *Rail Installation Guide* at www.dell.com/xcseriesmanuals.
8. [Remove the system cover](#).
9. [Remove the air shroud](#).
10. [Remove the expansion card riser from the system](#).
11. When removing a card from low profile, full height X1, or butterfly riser, ensure that the PCIe card holder latch is closed.
12. When installing a card into low profile, full height X1, or butterfly riser, open the PCIe card holder latch.
13. If installing a new expansion card, unpack it and prepare the card for installation.

NOTE: For instructions, see the documentation accompanying the card.

Steps

1. Open the expansion card retention latch.

2. If installed, remove the filler bracket.

NOTE: Store the filler bracket for future use. Filler brackets must be installed in empty expansion card slots to maintain Federal Communications Commission (FCC) certification of the system. The brackets also keep dust and dirt out of the system and aid in proper cooling and airflow inside the system.

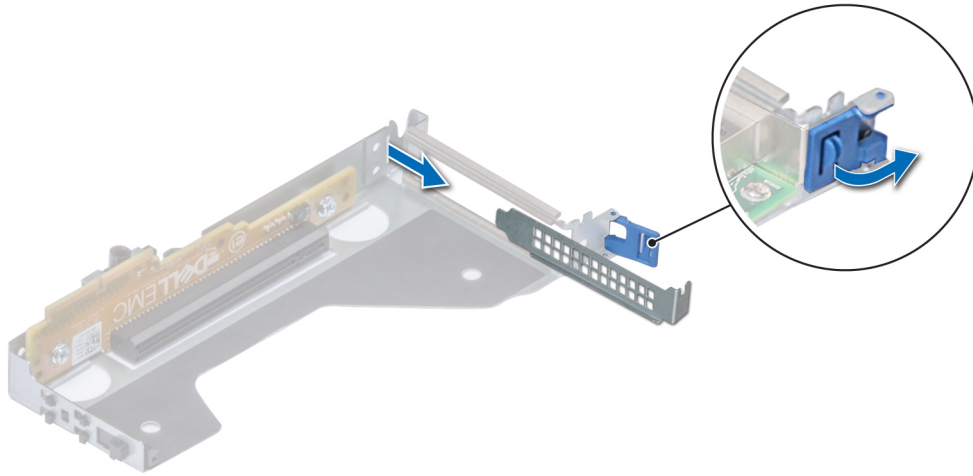

Figure 75. Removing filler bracket for low profile riser

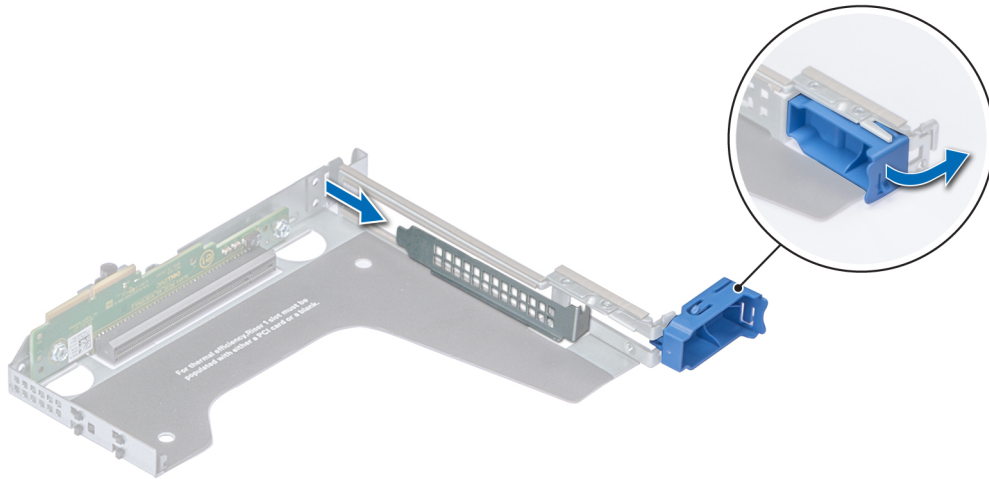

Figure 76. Removing filler bracket for full height X1 riser

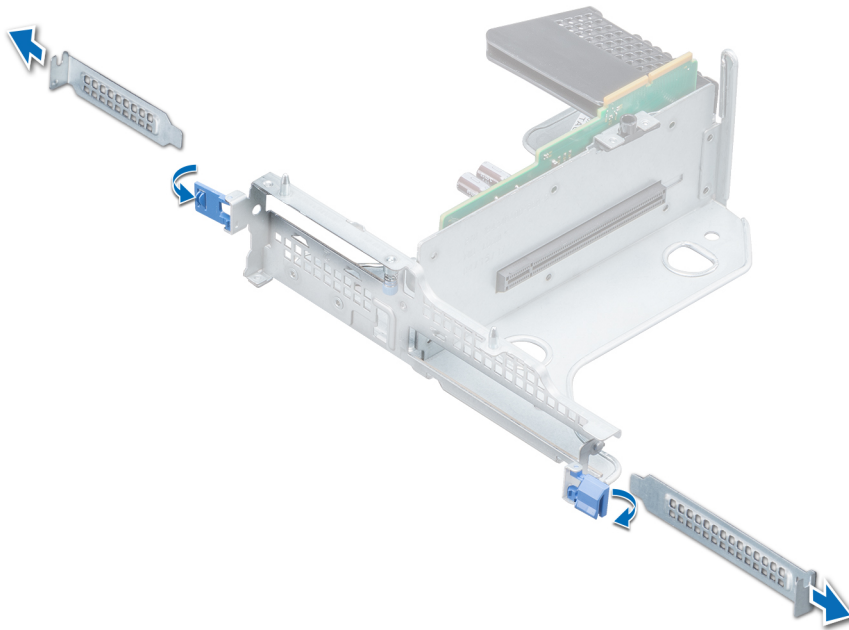

Figure 77. Removing filler bracket for butterfly riser

3. Hold the card by its edges, and align the card edge connector with the expansion card connector on the riser.
4. Insert the card edge connector firmly into the expansion card connector until the card is fully seated.
5. Close the expansion card retention latch.

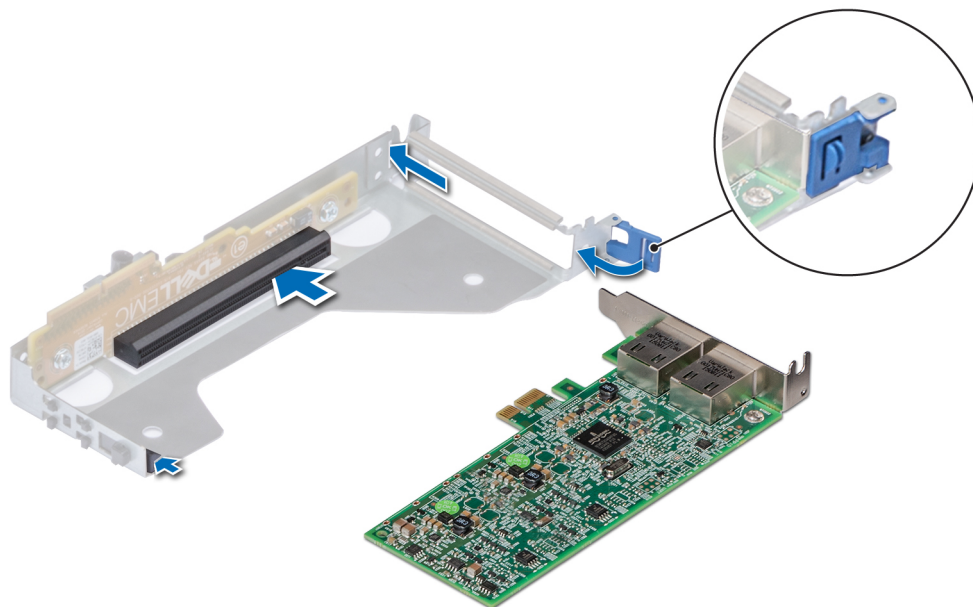

Figure 78. Installing expansion card into low profile riser

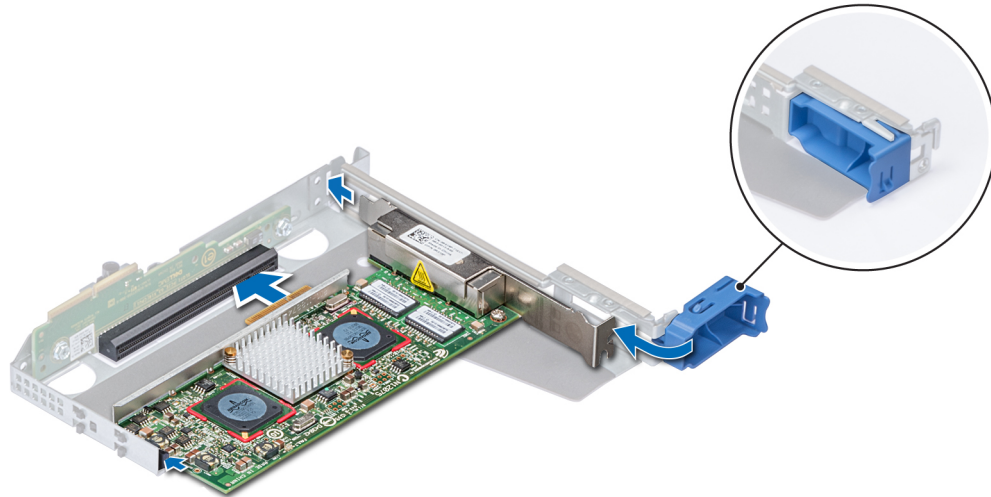

Figure 79. Installing expansion card into full height X1 riser

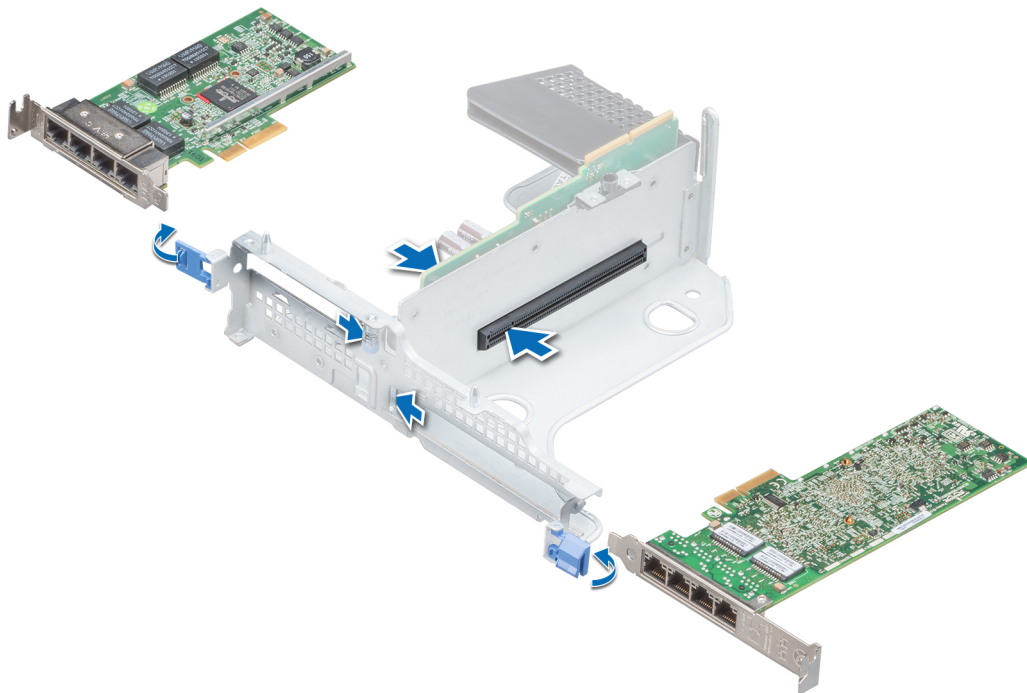

Figure 80. Installing expansion card into butterfly riser

Next steps

1. [Install the expansion card riser in the system.](#)
2. If applicable, connect the cables to the expansion card.
- 3.
4. [Install the air shroud.](#)
5. Install the [system cover](#).

6. Place the system into the rack. For more information, see the *Rail Installation Guide* at www.dell.com/xcseriesmanuals.
7. [Open the drive bays](#), install **all drives**, and then [close the drive bays](#).
8. Install the [power supply units](#).
9. Follow the procedure listed in [After working inside your system](#).
10. Install any device drivers required for the card as described in the documentation for the card.

Installing expansion card on the system board

Prerequisites

1. Follow the safety guidelines listed in [Safety Instructions](#).
2. Power off the system and all attached peripherals.
3. Disconnect the system from the electrical outlet, and disconnect the peripherals.
4. Ensure that all internal cables are routed correctly and connected, and no tools or extra parts are left inside the system.
5. [Open the drive bays](#), remove **all drives**, and then [close the drive bays](#).
6. Remove the [power supply units](#).
7. Remove the system from the rack and place it on an ESD work bench. For more information, see the *Rail Installation Guide* at www.dell.com/xcseriesmanuals.
8. [Remove the system cover](#).
9. [Remove the air shroud](#).
10. If installed, [remove the expansion card risers](#).

Steps

1. Unpack the expansion card and prepare it for installation.
For instructions, see the documentation accompanying the card.
2. If you are installing a new card, remove the filler bracket.
 - a) Press and lift the expansion card retention latch.
 - b) Pull the filler bracket upward out of the system.

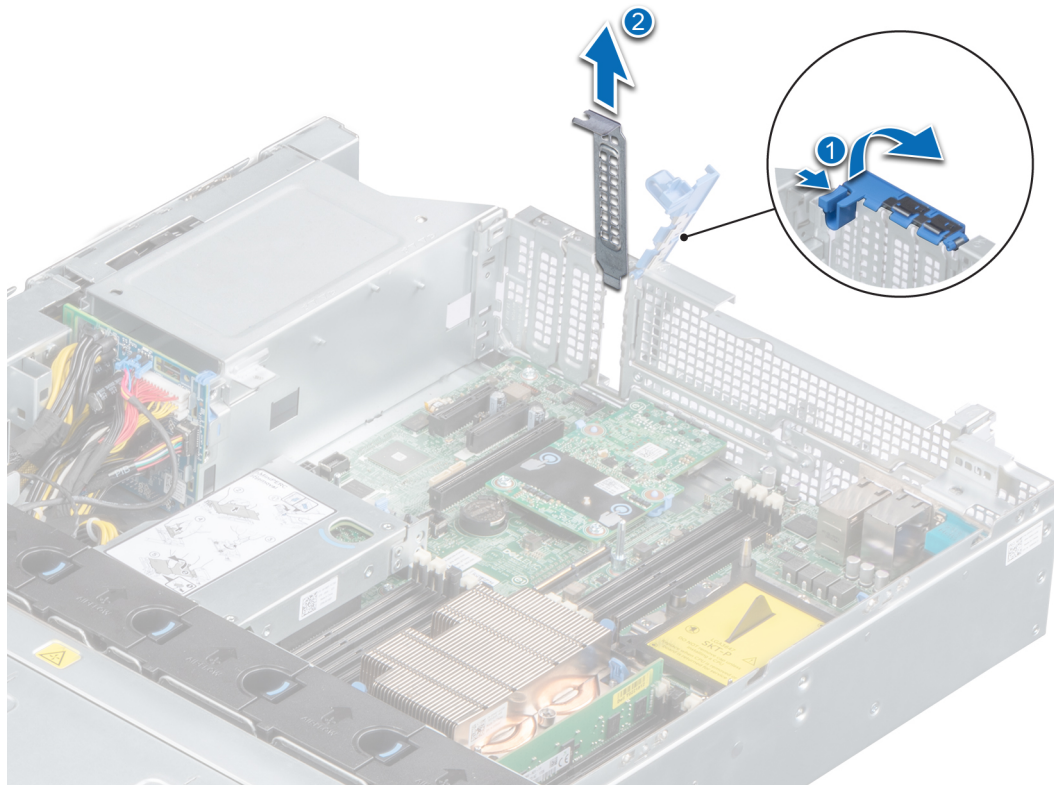

Figure 81. Removing the filler bracket

NOTE: Store the filler bracket for future use. Filler brackets must be installed in empty expansion card slots to maintain FCC certification of the system. The brackets also keep dust and dirt out of the system and aid in proper cooling and airflow inside the system.

3. Holding the card on the edges, align the card with the expansion card connector on the system board.
4. Press the expansion card firmly into the expansion card connector on the system board until the card is fully seated.
5. Close the retention latch by pressing the latch down until the latch snaps into place.

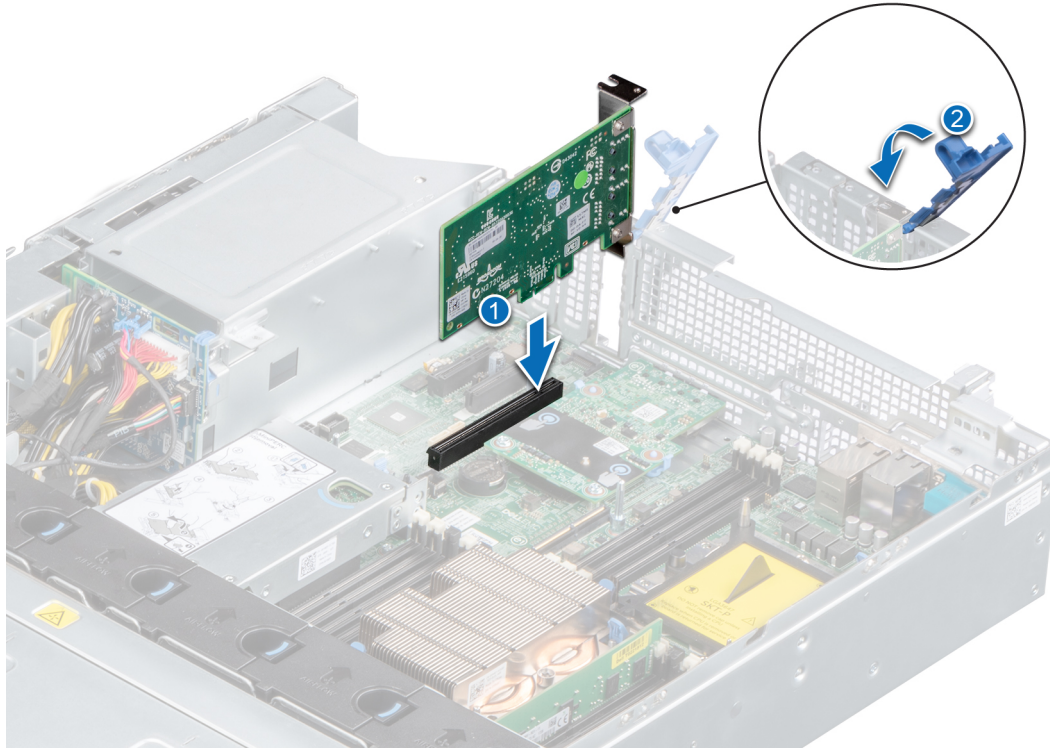

Figure 82. Installing expansion card on system board

Next steps

1. Connect the required cables to the expansion card.
- 2.
3. [Install the air shroud.](#)
4. Install the [system cover.](#)
5. Place the system into the rack. For more information, see the *Rail Installation Guide* at www.dell.com/xcseriesmanuals.
6. [Open the drive bays](#), install [all drives](#), and then [close the drive bays](#).
7. Install the [power supply units](#).
8. Follow the procedure listed in [After working inside your system](#).

Removing an expansion card riser

Prerequisites

1. Follow the safety guidelines listed in [Safety Instructions](#).
2. Power off the system and all attached peripherals.
3. Disconnect the system from the electrical outlet, and disconnect the peripherals.
4. [Open the drive bays](#), remove [all drives](#), and then [close the drive bays](#).
5. Remove the [power supply units](#).
6. Remove the system from the rack and place it on an ESD work bench. For more information, see the *Rail Installation Guide* at www.dell.com/xcseriesmanuals.
7. [Remove the system cover.](#)
8. [Remove the air shroud.](#)
9. Disconnect any cables connected to the expansion card.

Steps

Hold the touch points and lift the expansion card riser from the connector on the system board.

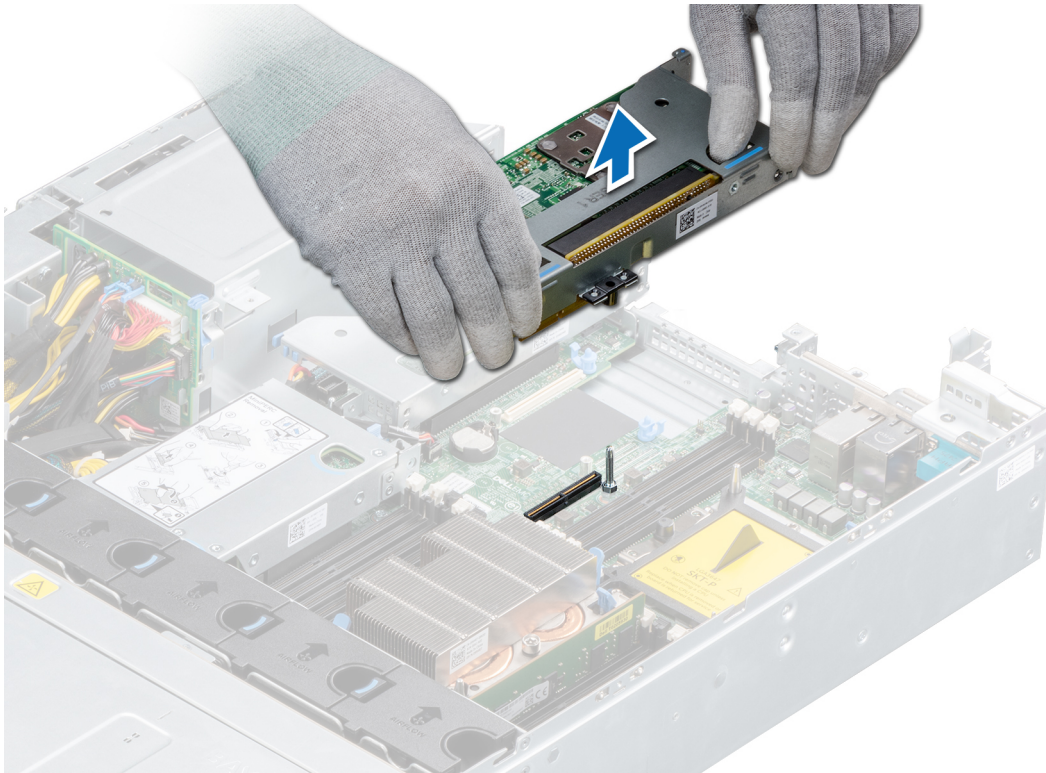

Figure 83. Removing right low profile riser

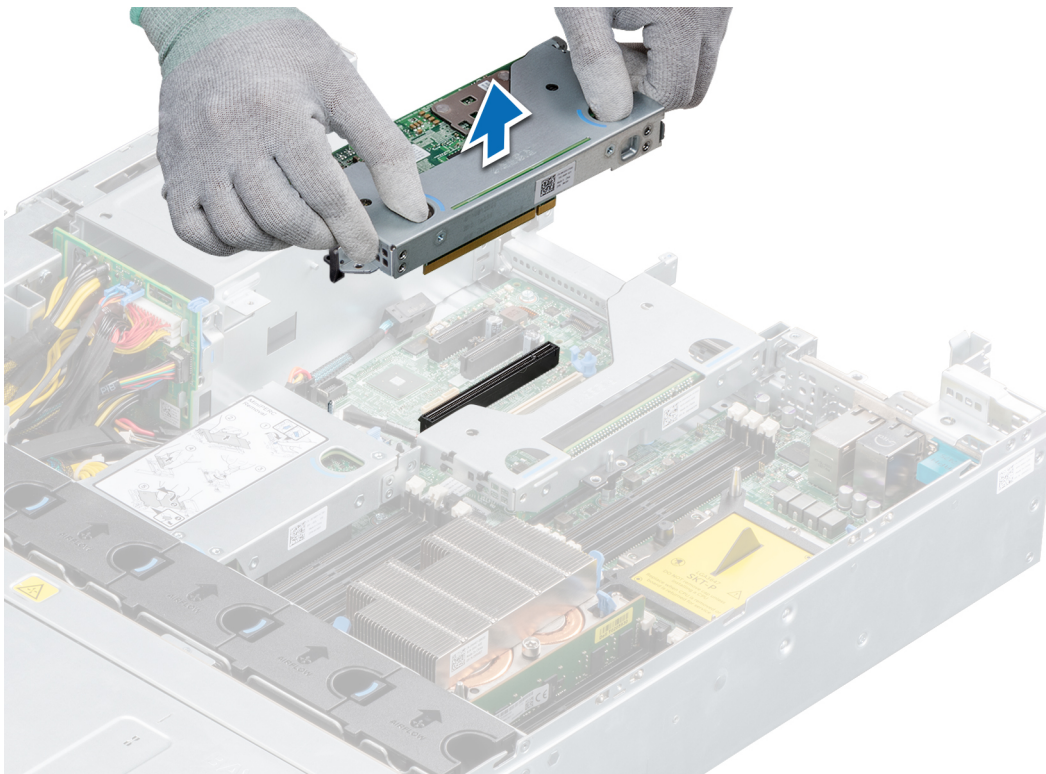

Figure 84. Removing left low profile riser

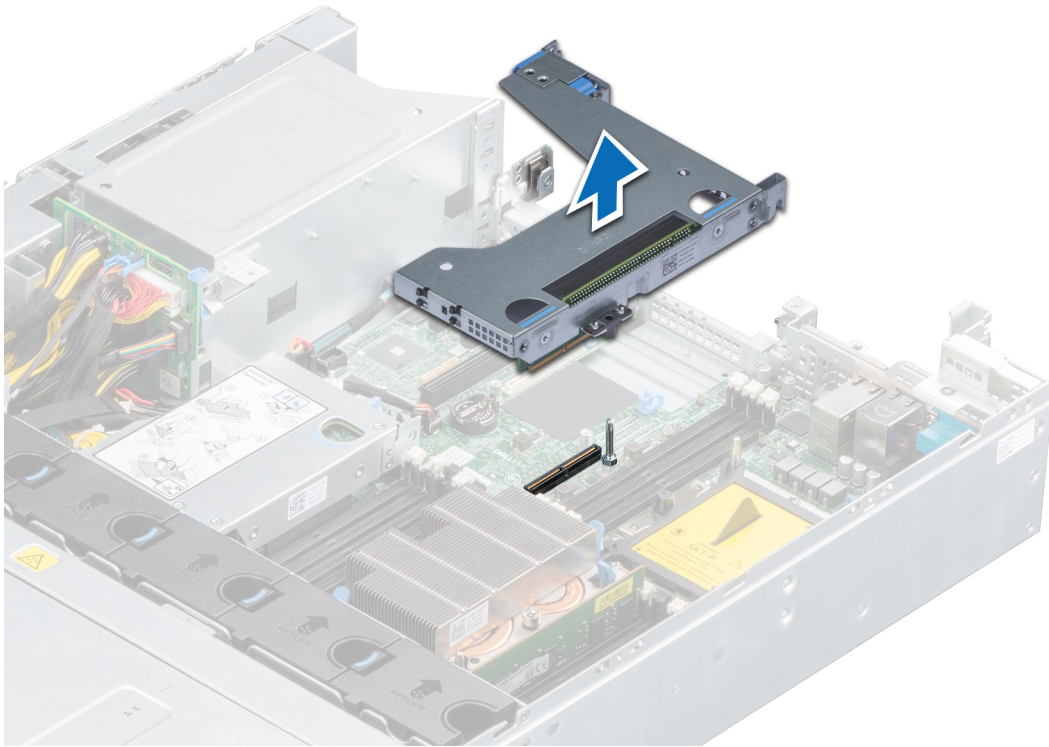

Figure 85. Removing full height X1 riser

NOTE: For butterfly riser, loosen the captive screw and holding the touch points lift the riser away from the system.

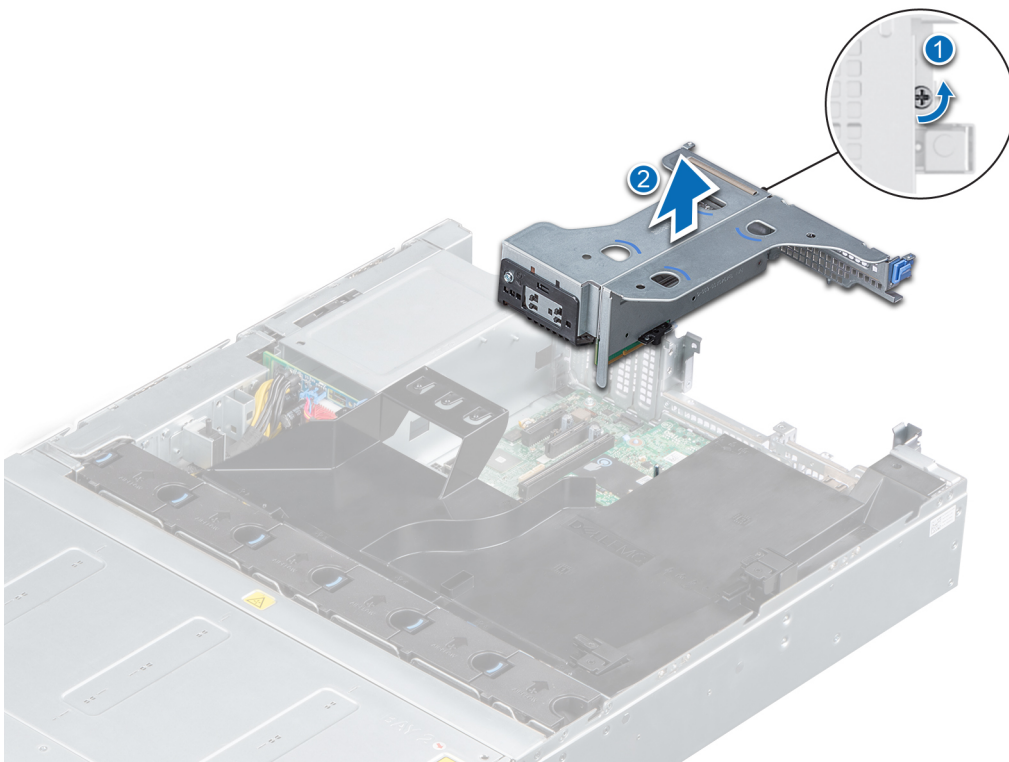

Figure 86. Removing butterfly riser

Next steps

Install the expansion card riser.

Installing an expansion card riser

Prerequisites

1. Follow the safety guidelines listed in [Safety Instructions](#).
2. Power off the system and all attached peripherals.
3. Disconnect the system from the electrical outlet, and disconnect the peripherals.
4. Ensure that all internal cables are routed correctly and connected, and no tools or extra parts are left inside the system.
5. [Open the drive bays](#), remove [all drives](#), and then [close the drive bays](#).
6. Remove the [power supply units](#).
7. Remove the system from the rack and place it on an ESD work bench. For more information, see the *Rail Installation Guide* at www.dell.com/xcseriesmanuals.
8. [Remove the system cover](#).
9. [Remove the air shroud](#).

Steps

1. If removed, install the expansion cards into the expansion card riser.
2. Holding the touch points, align the expansion card riser with the connector and the riser guide pin on the system board.
3. Lower the expansion card riser into place until the expansion card riser connector is fully seated in the connector.

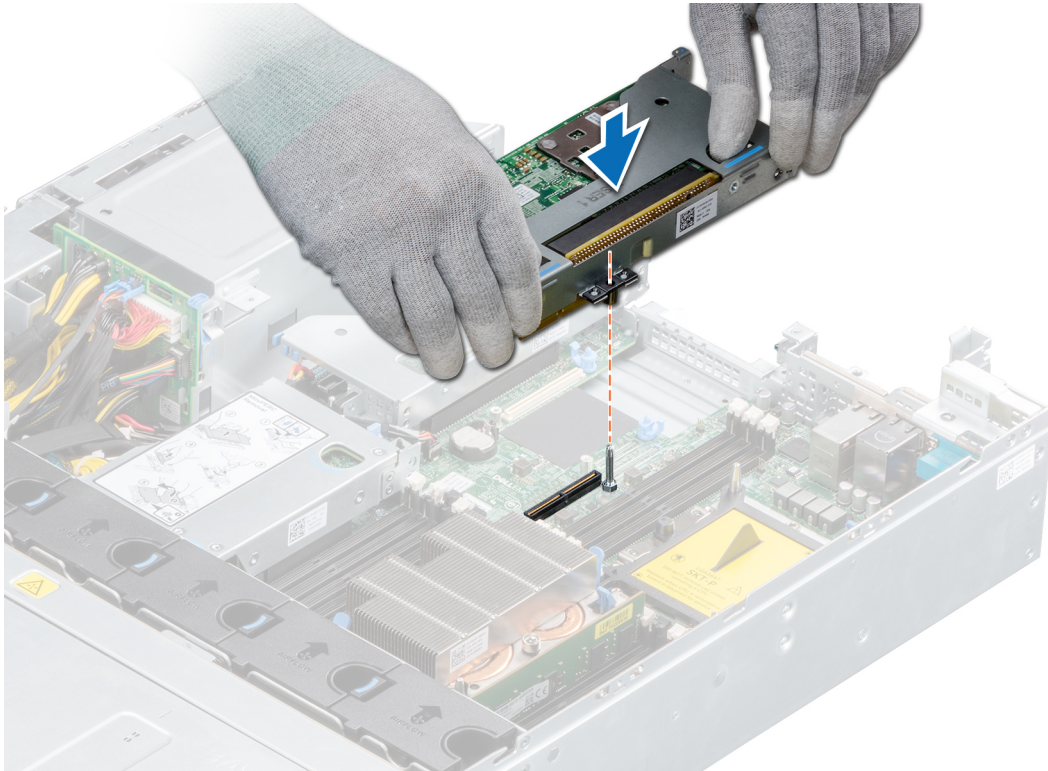

Figure 87. Installing right low profile riser

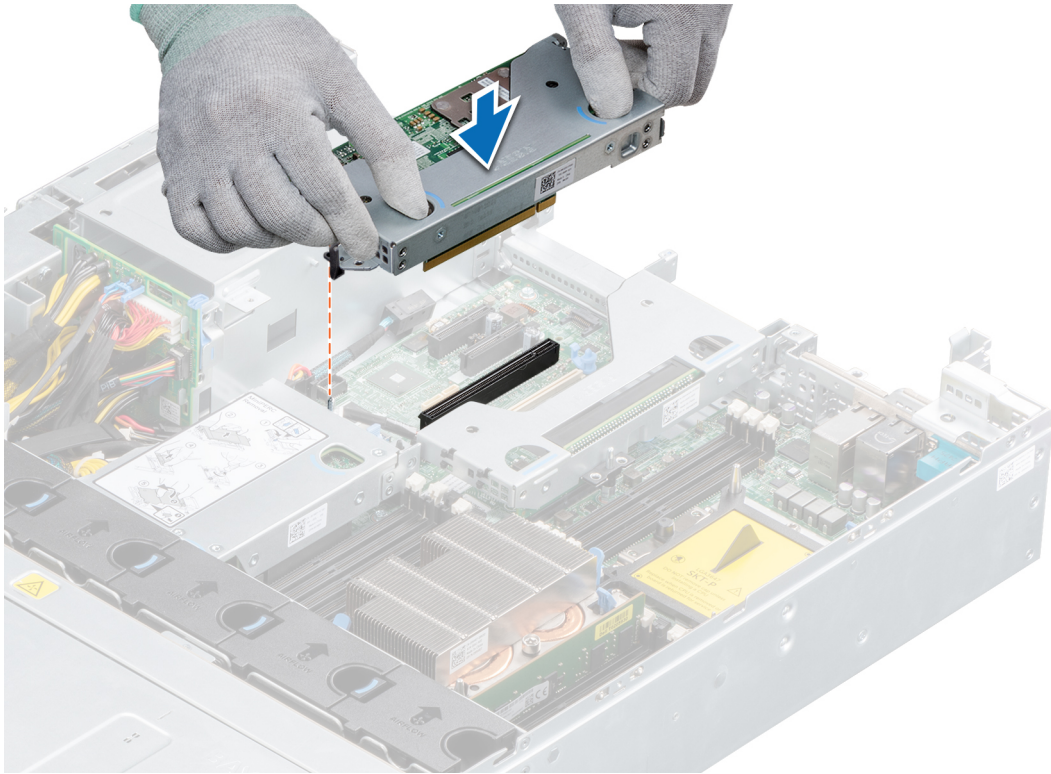

Figure 88. Installing left low profile riser

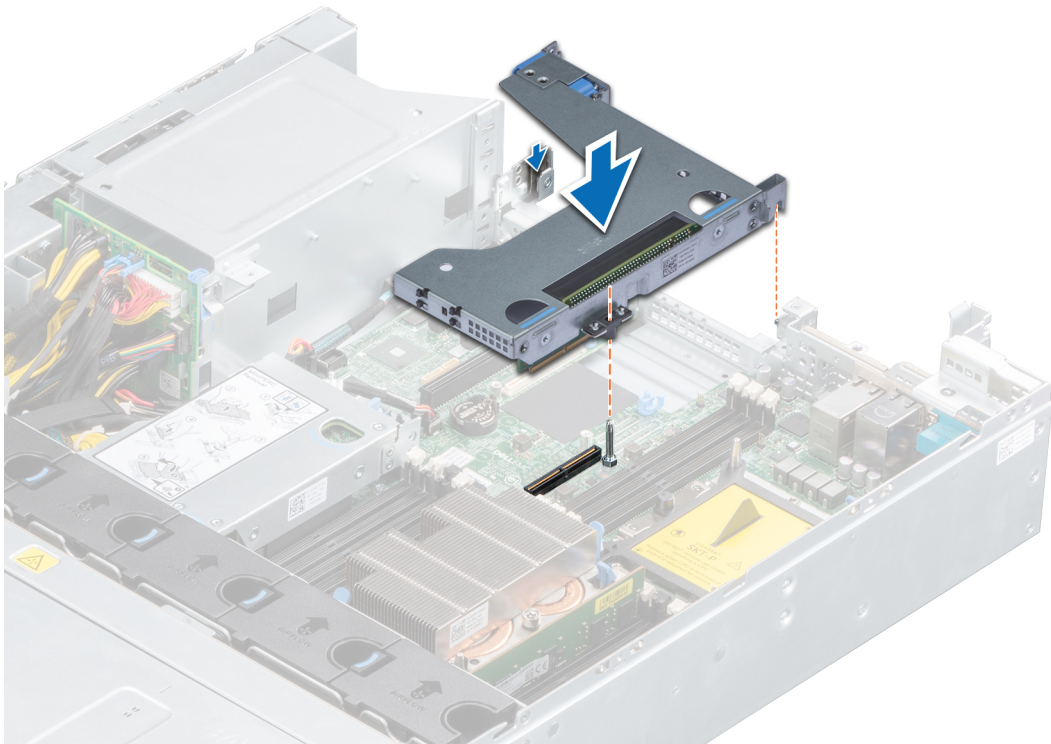

Figure 89. Installing full height X1 riser

NOTE: For butterfly riser, tighten the captive screw to firmly hold the riser to the system board.

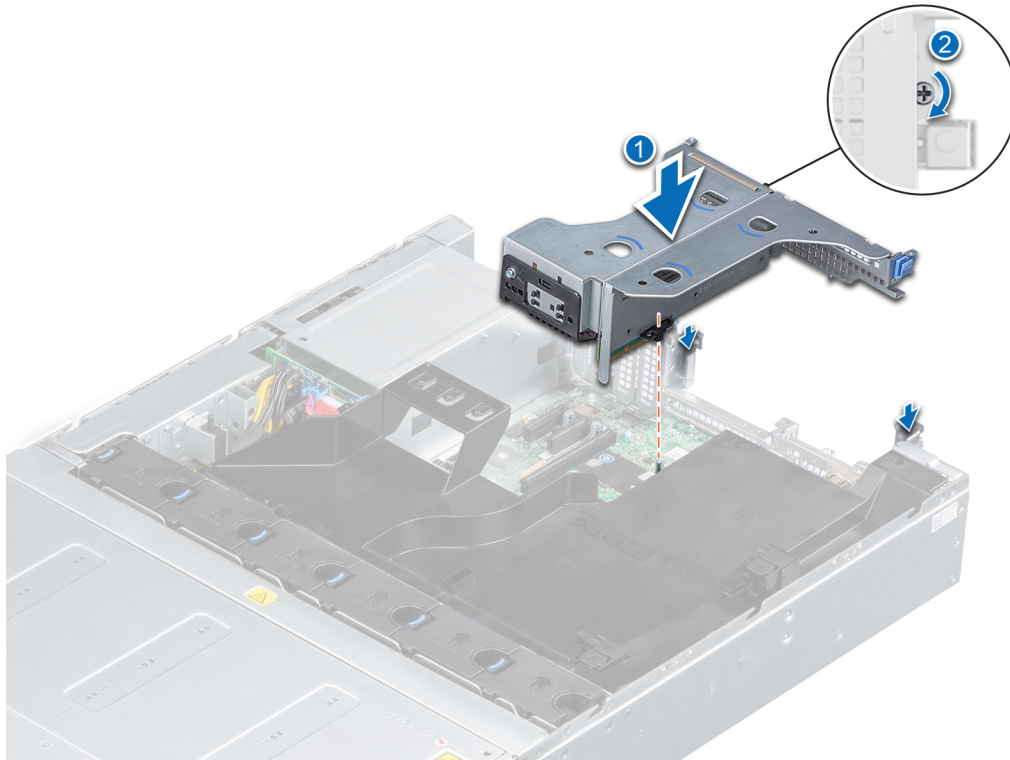

Figure 90. Installing butterfly riser

Next steps

- 1.
2. [Install the air shroud.](#)
3. Install the [system cover](#).
4. Place the system into the rack. For more information, see the *Rail Installation Guide* at www.dell.com/xcseriesmanuals.
5. [Open the drive bays](#), install [all drives](#), and then [close the drive bays](#).
6. Install the [power supply units](#).
7. Install any device drivers required for the card as described in the documentation for the card.
8. Follow the procedure listed in [After working inside your system](#).

M.2 SSD module

Removing the M.2 SSD module

Prerequisites

1. Follow the safety guidelines listed in [Safety Instructions](#).
2. Power off the system and all attached peripherals.
3. Disconnect the system from the electrical outlet, and disconnect the peripherals.
4. [Open the drive bays](#), remove [all drives](#), and then [close the drive bays](#).
5. Remove the [power supply units](#).
6. Remove the system from the rack and place it on an ESD work bench. For more information, see the *Rail Installation Guide* at www.dell.com/xcseriesmanuals.
7. [Remove the system cover](#).
8. [Remove the air shroud](#).
9. [Remove the BOSS card](#).
10.  **NOTE:** The procedure to remove the BOSS card is similar to the remove an expansion card.

Steps

1. Using the Phillips #1 screwdriver, remove the screws securing the M.2 SSD module to the BOSS card.
2. Pull the M.2 SSD module from the BOSS card connector.

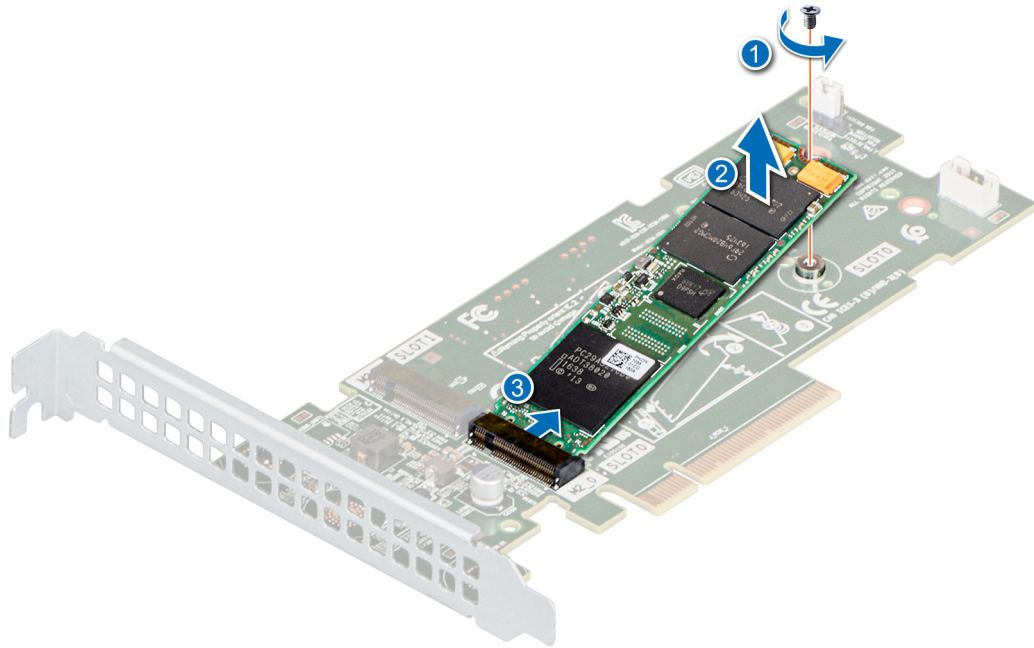

Figure 91. Removing the M.2 SSD module

Next steps

Replace the M.2 SSD module.

Installing the M.2 SSD module

Prerequisites

1. Follow the safety guidelines listed in [Safety Instructions](#).
2. Power off the system and all attached peripherals.
3. Disconnect the system from the electrical outlet, and disconnect the peripherals.
4. Ensure that all internal cables are routed correctly and connected, and no tools or extra parts are left inside the system.
5. [Open the drive bays](#), remove **all drives**, and then [close the drive bays](#).
6. Remove the [power supply units](#).
7. Remove the system from the rack and place it on an ESD work bench. For more information, see the *Rail Installation Guide* at www.dell.com/xcseriesmanuals.
8. [Remove the system cover](#).
9. [Remove the air shroud](#).
10. [Remove the BOSS card](#).

NOTE: The procedure to remove the BOSS card is similar to the removing an expansion card.

Steps

1. Insert the M.2 SSD module at an angle into the BOSS card connector.
2. Push the other end of the M.2 SSD module until it rests on the stand off on the BOSS card.
3. Using the Phillips #1 screwdriver, secure the M.2 SSD module on the BOSS card with the screw.

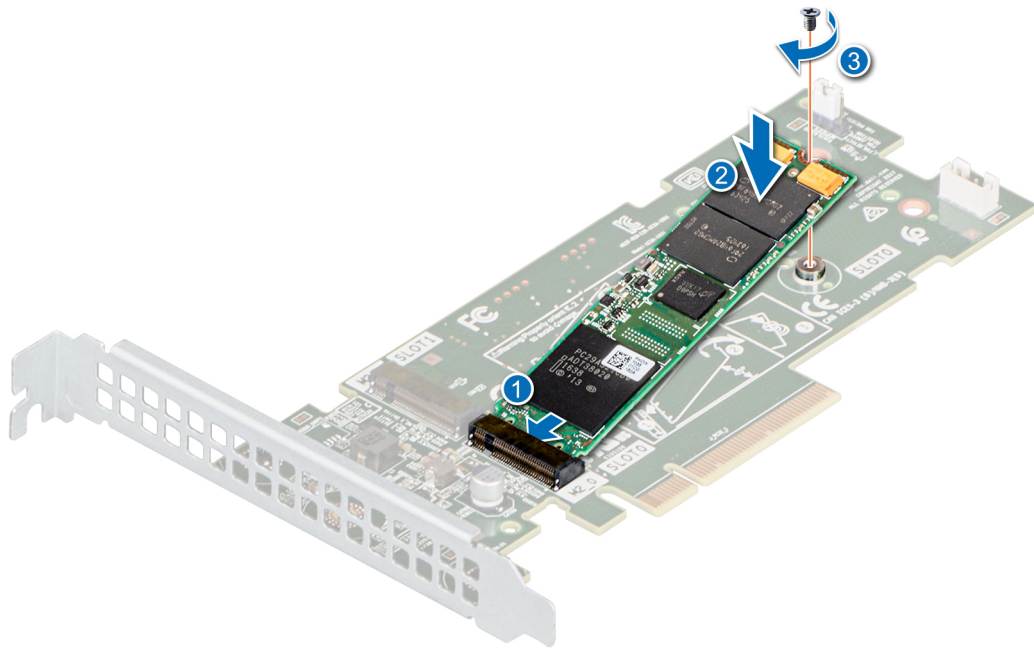

Figure 92. Installing the M.2 SSD module

Next steps

1. Install the BOSS card.
 - NOTE:** The procedure to install the BOSS card is similar to the installing an expansion card on the system board.
2. Install the air shroud.
3. Install the system cover.
4. Place the system into the rack. For more information, see the *Rail Installation Guide* at www.dell.com/xcseriesmanuals.
5. Open the drive bays, install all drives, and then close the drive bays.
6. Install the power supply units.
7. Follow the procedure listed in *After working inside your system*.

IDSDM / vFlash module

The write-protect switch is on the IDSDM module.

Removing the IDSDM/vFlash module

Prerequisites

1. Follow the safety guidelines listed in *Safety Instructions*.
2. Power off the system and all attached peripherals.
3. Disconnect the system from the electrical outlet, and disconnect the peripherals.
4. Open the drive bays, remove all drives, and then close the drive bays.
5. Remove the power supply units.
6. Remove the system from the rack and place it on an ESD work bench. For more information, see the *Rail Installation Guide* at www.dell.com/xcseriesmanuals.
7. Remove the system cover.
8. Remove the air shroud.

Steps

Holding the pull tab, lift the IDSDM/vFlash module out of the system board connector .

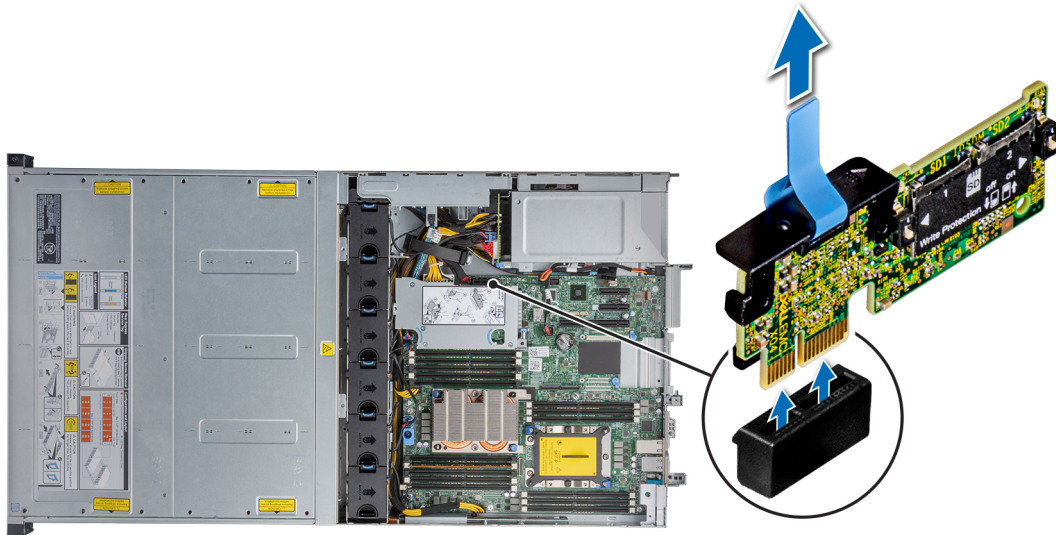

Figure 93. Removing the optional IDSDM or vFlash card

Next steps

i | **NOTE:** If you are replacing the IDSDM or vFlash module, remove the microSD cards.

Replace optional IDSDM/vFlash module.

Installing IDSDM/vFlash module

Prerequisites

1. Follow the safety guidelines listed in [Safety Instructions](#).
2. Power off the system and all attached peripherals.
3. Disconnect the system from the electrical outlet, and disconnect the peripherals.
4. Ensure that all internal cables are routed correctly and connected, and no tools or extra parts are left inside the system.
5. [Open the drive bays](#), remove **all drives**, and then [close the drive bays](#).
6. Remove the [power supply units](#).
7. Remove the system from the rack and place it on an ESD work bench. For more information, see the *Rail Installation Guide* at www.dell.com/xcseriesmanuals.
8. [Remove the system cover](#).
9. [Remove the air shroud](#).

Steps

Insert the IDSDM/vFlash module into the system board connector.

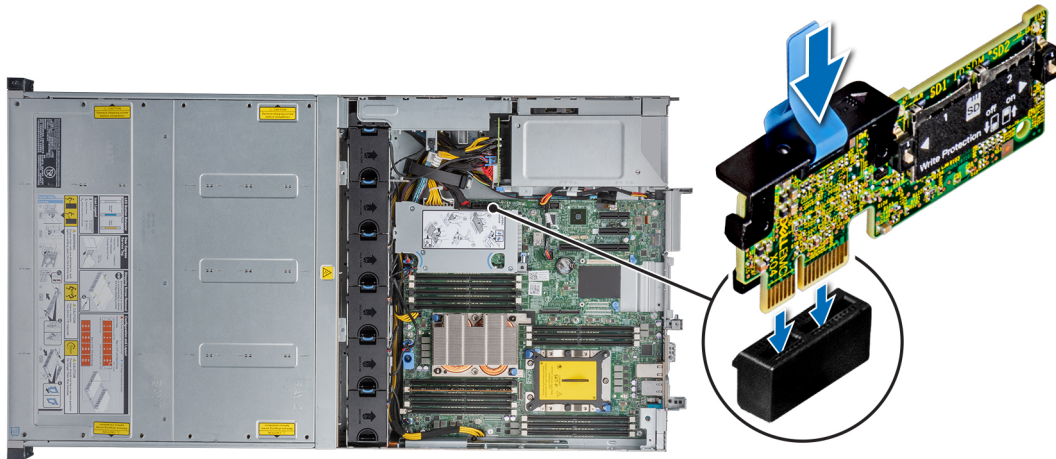

Figure 94. Installing optional IDSDM/vFlash card

Next steps

1. [Install the MicroSD cards.](#)
 - NOTE:** Reinstall the MicroSD cards into the same slots based on the labels you had marked on the cards during removal.
2. [Install the air shroud.](#)
3. [Install the system cover.](#)
4. Place the system into the rack. For more information, see the *Rail Installation Guide* at www.dell.com/xcseriesmanuals.
5. [Open the drive bays](#), install **all drives**, and then [close the drive bays](#).
6. [Install the power supply units.](#)
7. Follow the procedure listed in [After working inside your system](#).

Removing the MicroSD card

Prerequisites

1. Follow the safety guidelines listed in [Safety Instructions](#).
2. Power off the system and all attached peripherals.
3. Disconnect the system from the electrical outlet, and disconnect the peripherals.
4. [Open the drive bays](#), remove **all drives**, and then [close the drive bays](#).
5. Remove the [power supply units](#).
6. Remove the system from the rack and place it on an ESD work bench. For more information, see the *Rail Installation Guide* at www.dell.com/xcseriesmanuals.
7. [Remove the system cover.](#)
8. [Remove the air shroud.](#)
9. [Remove the IDSDM or vFlash module.](#)

Steps

1. Locate the MicroSD card slot on the IDSDM/vFlash module, and press the card to partially release it from the slot.
2. Hold the MicroSD card and remove it from the slot.

NOTE: Temporarily label each MicroSD card with its corresponding slot number after removal.

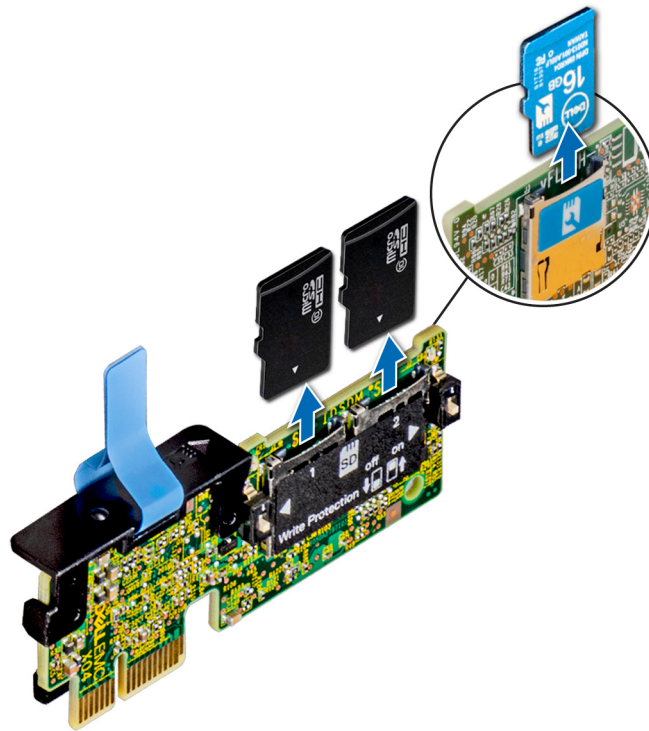

Figure 95. Removing the MicroSD card

Next steps

Replace the MicroSD card.

Installing the MicroSD card

Prerequisites

1. Follow the safety guidelines listed in [Safety Instructions](#).
2. Power off the system and all attached peripherals.
3. Disconnect the system from the electrical outlet, and disconnect the peripherals.
4. Ensure that all internal cables are routed correctly and connected, and no tools or extra parts are left inside the system.
5. [Open the drive bays](#), remove [all drives](#), and then [close the drive bays](#).
6. Remove the [power supply units](#).
7. Remove the system from the rack and place it on an ESD work bench. For more information, see the *Rail Installation Guide* at www.dell.com/xcseriesmanuals.
8. [Remove the system cover](#).
9. [Remove the air shroud](#).
10. [Remove the IDSDM or vFlash module](#).

NOTE: To use an MicroSD card with your system, ensure that the Internal SD Card Port is enabled in System Setup.

NOTE: If reinstalling, ensure that you install the MicroSD cards into the same slots based on the labels you had marked on the cards during removal.

Steps

1. Locate the MicroSD card connector on the IDSDM/vFlash module. Orient the MicroSD card appropriately and insert the contact-pin end of the card into the slot.
NOTE: The slot is designed to ensure correct insertion of the card.
2. Press the card into the card slot to lock it into place.

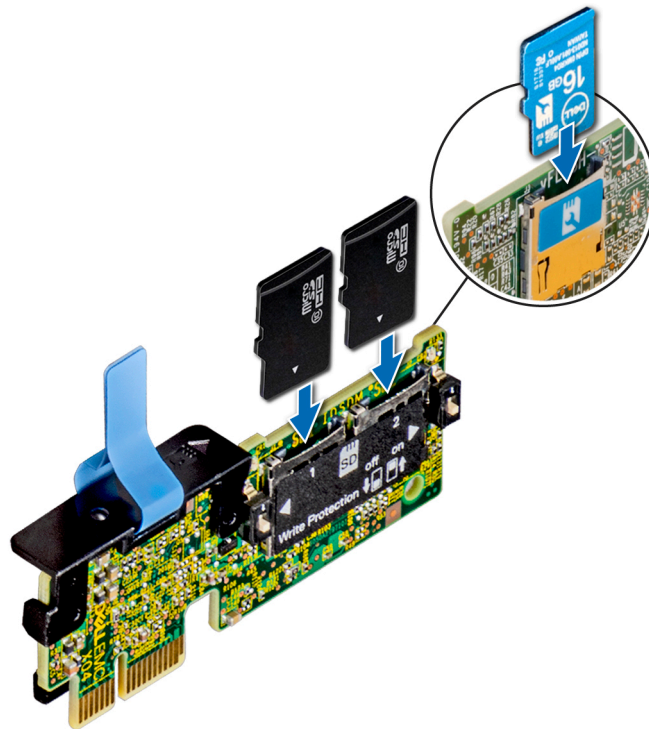

Figure 96. Installing the MicroSD card

Next steps

1. Install the [IDSDM or vFlash module](#)
2. Install the [air shroud](#).
3. Install the [system cover](#).
4. Place the system into the rack. For more information, see the *Rail Installation Guide* at www.dell.com/xcseriesmanuals.
5. [Open the drive bays](#), install [all drives](#), and then [close the drive bays](#).
6. Install the [power supply units](#).
7. Follow the procedure listed in [After working inside your system](#).

LOM riser card

Removing the LOM riser card

Prerequisites

1. Follow the safety guidelines listed in [Safety Instructions](#).
2. Power off the system and all attached peripherals.
3. Disconnect the system from the electrical outlet, and disconnect the peripherals.
4. [Open the drive bays](#), remove [all drives](#), and then [close the drive bays](#).
5. Remove the [power supply units](#).
6. Remove the system from the rack and place it on an ESD work bench. For more information, see the *Rail Installation Guide* at www.dell.com/xcseriesmanuals.
7. [Remove the system cover](#).
8. [Remove the air shroud](#).
9. If installed, [remove the risers](#).

Steps

1. Using a Phillips #2 screwdriver, loosen the screws that secure the LOM riser card to the system board.
2. Release the two blue plastic clips holding the LOM riser card.
3. Hold the LOM riser card by the edges on either side, and lift to remove it from the connector on the system board.

- Slide the LOM riser card towards the front of the system until the Ethernet connectors or the Small form-factor pluggable (SFP) are clear of the slot in the back of the system.

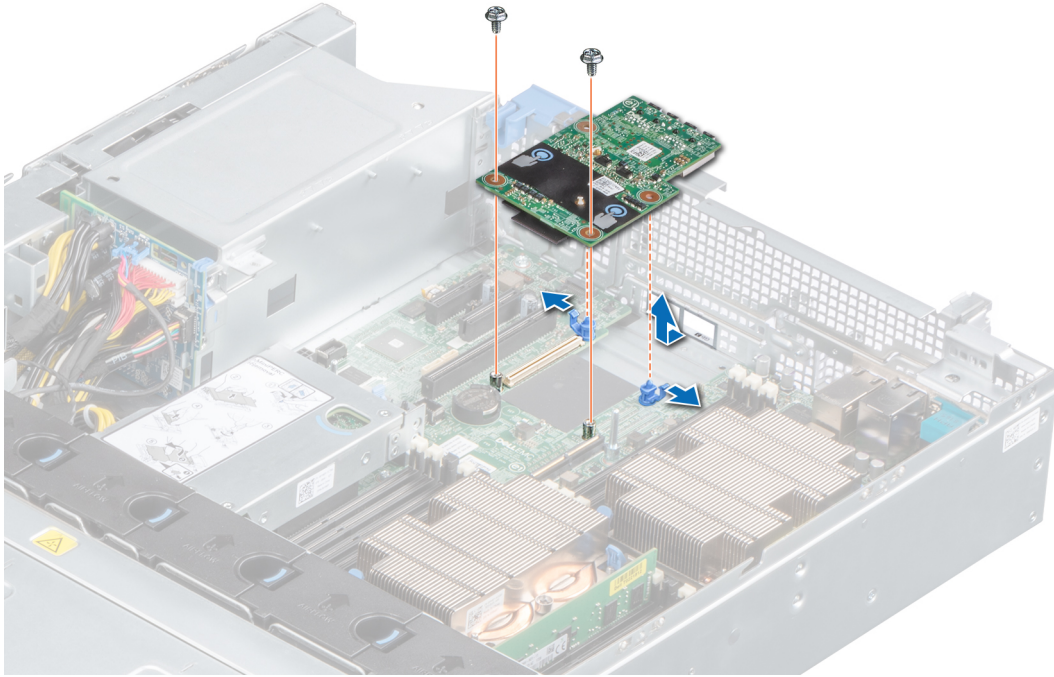

Figure 97. Removing LOM riser card

Next steps

Replace the LOM riser card.

Installing the LOM riser card

Prerequisites

- Follow the safety guidelines listed in [Safety Instructions](#).
- Power off the system and all attached peripherals.
- Disconnect the system from the electrical outlet, and disconnect the peripherals.
- Ensure that all internal cables are routed correctly and connected, and no tools or extra parts are left inside the system.
- [Open the drive bays](#), remove [all drives](#), and then [close the drive bays](#).
- Remove the [power supply units](#).
- Remove the system from the rack and place it on an ESD work bench. For more information, see the *Rail Installation Guide* at www.dell.com/xcseriesmanuals.
- [Remove the system cover](#).
- [Remove the air shroud](#).
- If installed, [remove the risers](#).

Steps

- Align the connectors on the LOM riser card with the slot on the system.
- Press the LOM riser card until the card is firmly seated on the system board connector and the two blue plastic clips hold the LOM riser card in place.
- Using a Phillips #2 screwdriver, replace the screws to secure the LOM riser card to the system board.

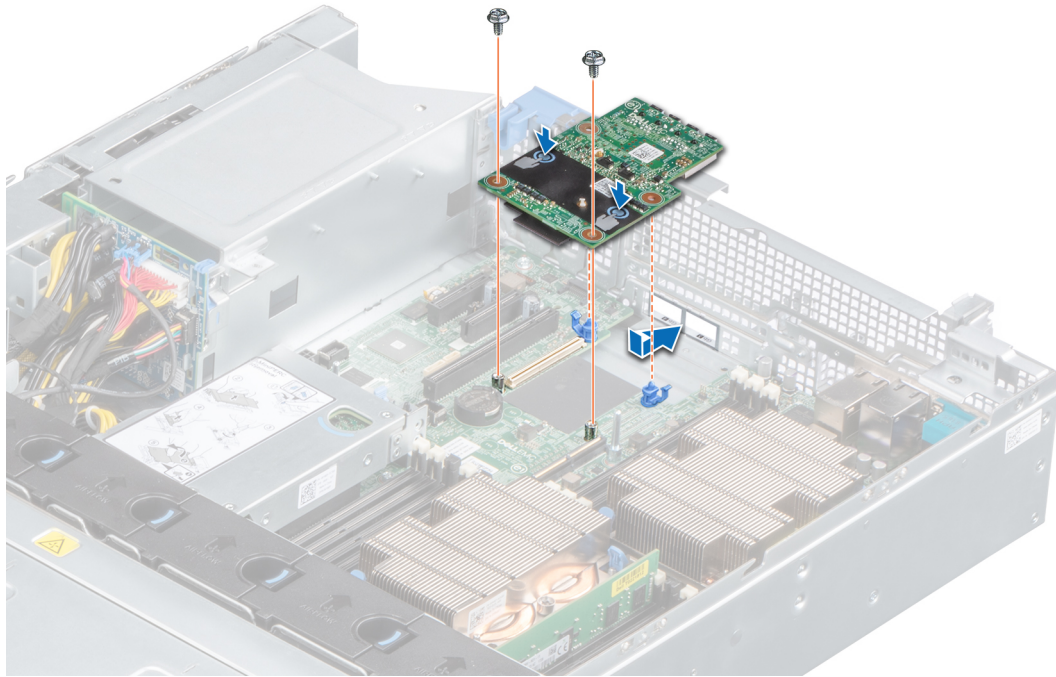

Figure 98. Installing LOM riser card

Next steps

1. If removed, [install the risers](#).
- 2.
3. [Install the air shroud](#).
4. Install the [system cover](#).
5. Place the system into the rack. For more information, see the *Rail Installation Guide* at www.dell.com/xcseriesmanuals.
6. [Open the drive bays](#), install [all drives](#), and then [close the drive bays](#).
7. Install the [power supply units](#).
8. Follow the procedure listed in [After working inside your system](#).

System battery

Replacing the system battery

Prerequisites

⚠ WARNING: There is a danger of a new battery exploding if it is incorrectly installed. Replace the battery only with the same or equivalent type recommended by the manufacturer. For more information, see the safety information that shipped with your system.

1. Follow the safety guidelines listed in [Safety Instructions](#).
2. Power off the system and all attached peripherals.
3. Disconnect the system from the electrical outlet, and disconnect the peripherals.
4. Ensure that all internal cables are routed correctly and connected, and no tools or extra parts are left inside the system.
5. [Open the drive bays](#), remove [all drives](#), and then [close the drive bays](#).
6. Remove the [power supply units](#).
7. Remove the system from the rack and place it on an ESD work bench. For more information, see the *Rail Installation Guide* at www.dell.com/xcseriesmanuals.
8. [Remove the system cover](#).
9. [Remove the air shroud](#).
10. If applicable, disconnect the power or data cables from expansion card(s).
11. If installed, [remove the low profile or full height X1 expansion card risers](#).

Steps

1. Locate the battery socket.

 **CAUTION:** To avoid damage to the battery connector, you must firmly support the connector while installing or removing a battery.

2. Use a plastic scribe to pry out the system battery.

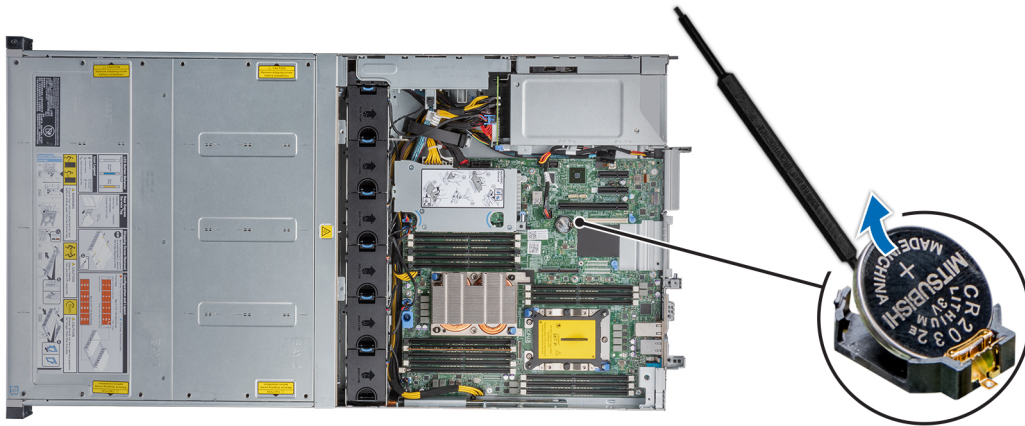

Figure 99. Removing the system battery

3. To install a new system battery, hold the battery with the positive side facing up and slide it under the securing tabs.
4. Press the battery into the connector until it snaps into place.

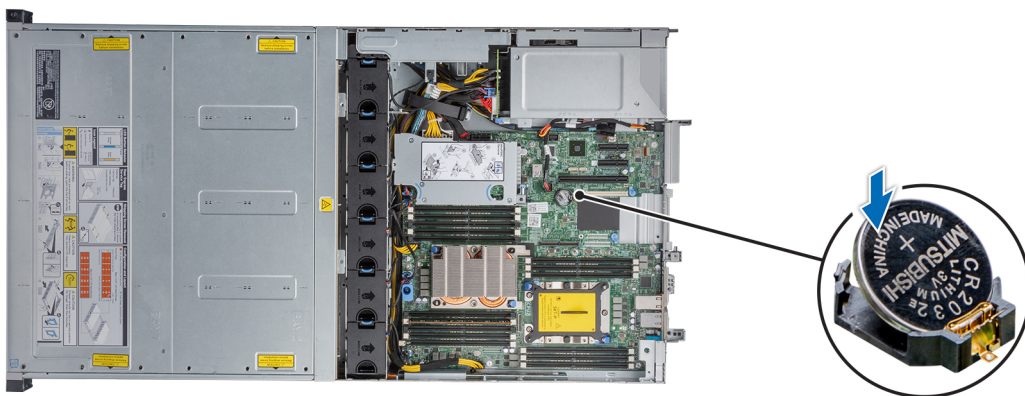

Figure 100. Installing the system battery

Next steps

1. If removed, [install the low profile or full height X1 expansion card risers](#).
2. If applicable, connect the cables to the expansion card(s).
3. [Install the air shroud](#).
4. Install the [system cover](#).
5. Place the system into the rack. For more information, see the *Rail Installation Guide* at www.dell.com/xcseriesmanuals.
6. [Open the drive bays](#), install [all drives](#), and then [close the drive bays](#).
7. Install the [power supply units](#).
8. Follow the procedure listed in [After working inside your system](#).
9. While booting, press F2 to enter the System Setup and ensure that the battery is operating properly.
10. Enter the correct time and date in the System Setup **Time** and **Date** fields.

11. Exit the System Setup.

Power supply unit

NOTE: For more information, see the [Technical specifications](#) section.

Hot spare feature

Your system supports the hot spare feature that significantly reduces the power overhead associated with power supply unit (PSU) redundancy.

When the hot spare feature is enabled, one of the redundant PSUs is switched to the sleep state. The active PSU supports 100 percent of the load, thus operating at higher efficiency. The PSU in the sleep state monitors output voltage of the active PSU. If the output voltage of the active PSU drops, the PSU in the sleep state returns to an active output state.

If having both PSUs active is more efficient than having one PSU in the sleep state, the active PSU can also activate the sleeping PSU.

The default PSU settings are as follows:

- If the load on the active PSU is more than 50 percent, then the redundant PSU is switched to the active state.
- If the load on the active PSU falls below 20 percent, then the redundant PSU is switched to the sleep state.

You can configure the hot spare feature by using the iDRAC settings. For more information about iDRAC settings, see the *Integrated Dell Remote Access Controller User's Guide* available at www.dell.com/idracmanuals.

Removing a power supply unit blank

Prerequisites

Follow the safety guidelines listed in [Safety Instructions](#).

Steps

If you are installing a second power supply unit, remove the power supply unit blank in the bay by pulling the blank outward.

CAUTION: To ensure proper system cooling, the power supply unit blank must be installed in the second power supply unit bay in a non-redundant configuration. Remove the power supply unit blank only if you are installing a second power supply unit.

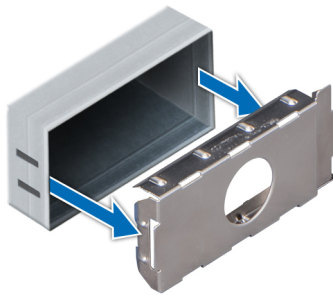

Figure 101. Removing a power supply unit blank

Next steps

Replace a power supply unit blank.

Installing a power supply unit blank

Prerequisites

1. Follow the safety guidelines listed in [Safety Instructions](#).

NOTE: If the system is using only one PSU, the PSU must be installed in PSU bay 1 and the PSU blank must be installed in PSU bay 2.

Steps

Align the PSU blank with the PSU bay and push it into the PSU bay until it clicks into place.

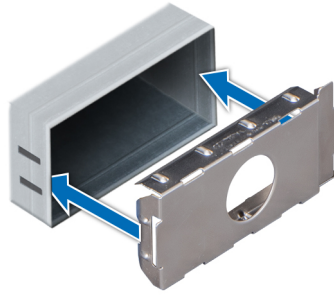

Figure 102. Installing a power supply unit blank

Next steps

Follow the procedure listed in [After working inside your system](#).

Removing a power supply unit

The procedure for removing AC and DC PSUs is identical.

Prerequisites

CAUTION: The system needs one power supply unit (PSU) for normal operation. On power-redundant systems, remove and replace only one PSU at a time in a system that is powered on.

1. Follow the safety guidelines listed in [Safety Instructions](#).
2. Disconnect the power cable from the power source and from the PSU you intend to remove, and then remove the cable from the strap on the PSU handle.

Steps

Press the release latch and slide the PSU out of the system by using the PSU handle.

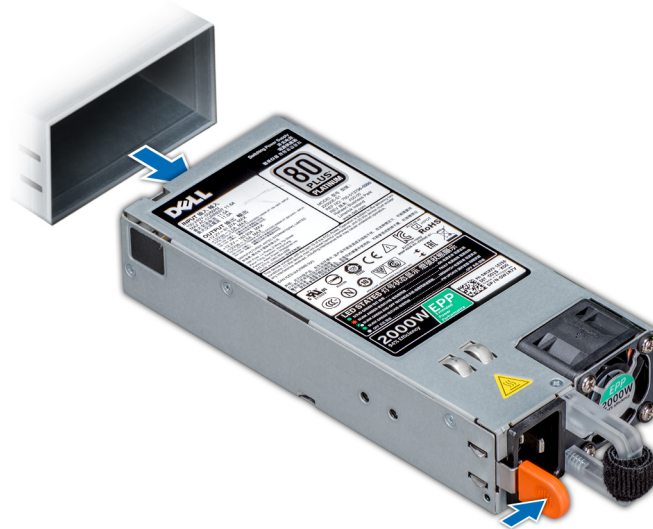

Figure 103. Removing a power supply unit

Next steps

Replace a power supply unit.

Installing a power supply unit

The procedure for installing AC and DC PSUs is identical.

Prerequisites

1. Follow the safety guidelines listed in [Safety Instructions](#).
2. Ensure that both the PSUs are of the same type and have the same maximum output power.

NOTE: The maximum output power (shown in watts) is listed on the PSU label.

Steps

Slide the PSU into the PSU bay until the PSU is fully seated and the release latch snaps into place.

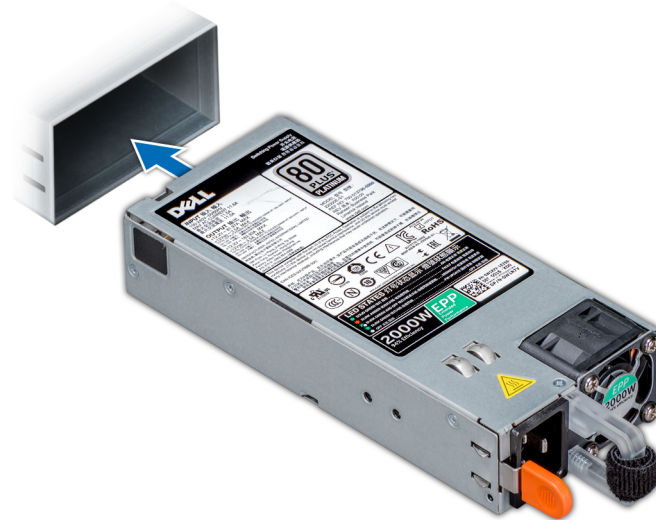

Figure 104. Installing a power supply unit

Next steps

1. Connect the power cable to the PSU, and plug the cable into a power outlet.

CAUTION: When connecting the power cable to the PSU, secure the cable to the PSU with the strap provided on the handle.

NOTE: When installing, hot swapping, or hot adding a new PSU, wait for 15 seconds for the system to recognize the PSU and determine its status. The PSU redundancy may not occur until discovery is complete. Wait until the new PSU is discovered and enabled before you remove the other PSU. The PSU status indicator turns green to signify that the PSU is functioning properly.

Removing a DC power supply unit

Prerequisites

NOTE: For equipment using $-(48-60)$ V DC power supply units (PSUs), a qualified electrician must perform all connections to DC power and to safety grounds. Do not attempt connecting to DC power or installing grounds yourself. All electrical wiring must comply with applicable local or national codes and practices. Damage due to servicing that is not authorized by Dell is not covered by your warranty. Read and follow all safety instructions that came with the product.

CAUTION: The system needs one PSU for normal operation. On power-redundant systems, remove and replace only one PSU at a time in a system that is powered on.

1. Follow the safety guidelines listed in [Safety Instructions](#).
2. Disconnect the power wires from the power source and the connector from the PSU you intend to remove.

3. Disconnect the safety ground wire.

Steps

Press the release latch and slide the PSU out of the system by using the PSU handle.

Next steps

[Replace the DC PSU.](#)

Installing DC power supply unit

Prerequisites

NOTE: For equipment using $-(48-60)$ V DC power supply units (PSUs), a qualified electrician must perform all connections to DC power and to safety grounds. Do not attempt connecting to DC power or installing grounds yourself. All electrical wiring must comply with applicable local or national codes and practices. Damage due to servicing that is not authorized by Dell is not covered by your warranty. Read and follow all safety instructions that came with the product.

1. Follow the safety guidelines listed in [Safety Instructions](#).
2. For systems that support redundant power supply units (PSUs), ensure that both the PSUs are of the same type and have the same maximum output power.

NOTE: The maximum output power (shown in watts) is listed on the PSU label.

Steps

Slide the PSU into the system until the PSU is fully seated and the release latch snaps into place.

Next steps

1. Connect the safety ground wire.
2. Install the DC power connector in the PSU.
CAUTION: When connecting the power wires, ensure that you secure the wires with the strap to the PSU handle.
3. Connect the wires to a DC power source.
NOTE: When installing, hot-swapping, or hot-adding a new PSU, wait for 15 seconds for the system to recognize the PSU and determine its status. The PSU status indicator turns green to signify that the PSU is functioning properly.

Power interposer board

Removing power interposer board

Prerequisites

1. Follow the safety guidelines listed in [Safety Instructions](#).
2. Power off the system and all attached peripherals.
3. Disconnect the system from the electrical outlet, and disconnect the peripherals.
4. [Open the drive bays](#), remove [all drives](#), and then [close the drive bays](#).
5. Remove the [power supply units](#).
6. Remove the system from the rack and place it on an ESD work bench. For more information, see the *Rail Installation Guide* at www.dell.com/xcseriesmanuals.
7. [Remove the system cover](#).
8. [Remove the air shroud](#).
9. Disconnect all the cables from the power interposer board (PIB).

CAUTION: To prevent damage to the power interposer board, you must remove the power supply module (s) from the system before removing the power interposer board.

NOTE: Ensure that you note the routing of the cables as you remove them from the system board.

Steps

1. Press the blue release tab on the PIB to release it from the hook on the PSU cage.
2. Lift the board and slide it out at an angle to disengage the guide pins on the board.

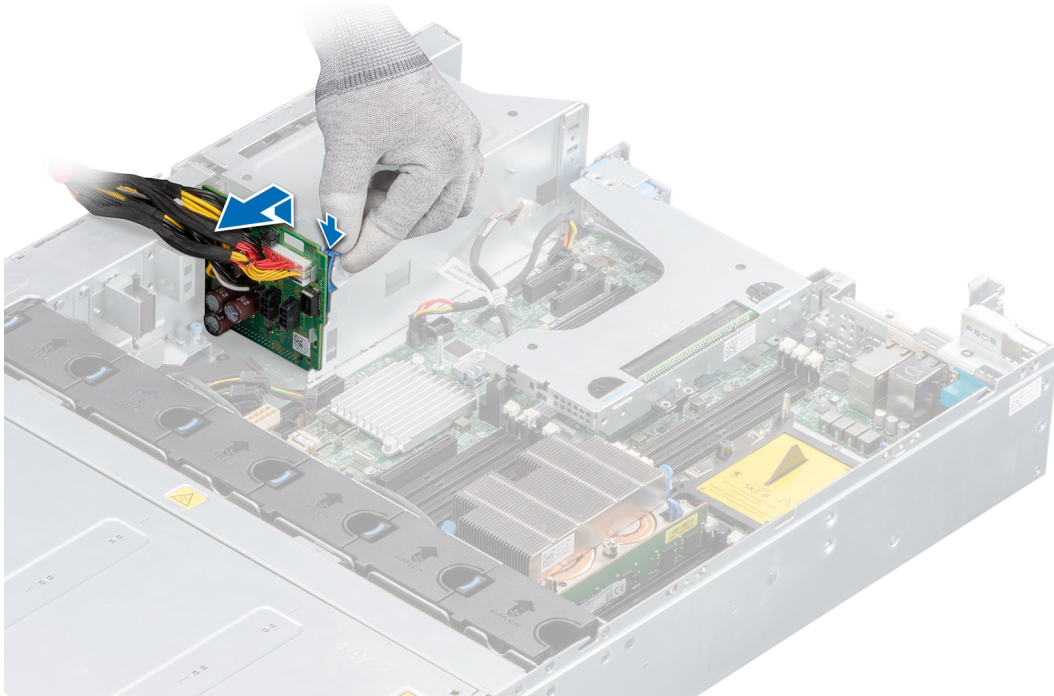

Figure 105. Removing power interposer board

Next steps

Replace the power interposer board.

Installing power interposer board

Prerequisites

1. Follow the safety guidelines listed [Safety Instructions](#).
2. Power off the system and all attached peripherals.
3. Disconnect the system from the electrical outlet, and disconnect the peripherals.
4. Ensure that all internal cables are routed correctly and connected, and no tools or extra parts are left inside the system.
5. [Open the drive bays](#), remove [all drives](#), and then [close the drive bays](#).
6. Remove the [power supply units](#).
7. Remove the system from the rack and place it on an ESD work bench. For more information, see the *Rail Installation Guide* at www.dell.com/xcseriesmanuals.
8. [Remove the system cover](#).
9. [Remove the air shroud](#).
10. Disconnect all the cables connected to the system board.

Steps

1. Press the blue release tab and align the slots on the PIB with the hooks on the PSU cage and slide it into place.
2. Route the cables and connect it to the system board.

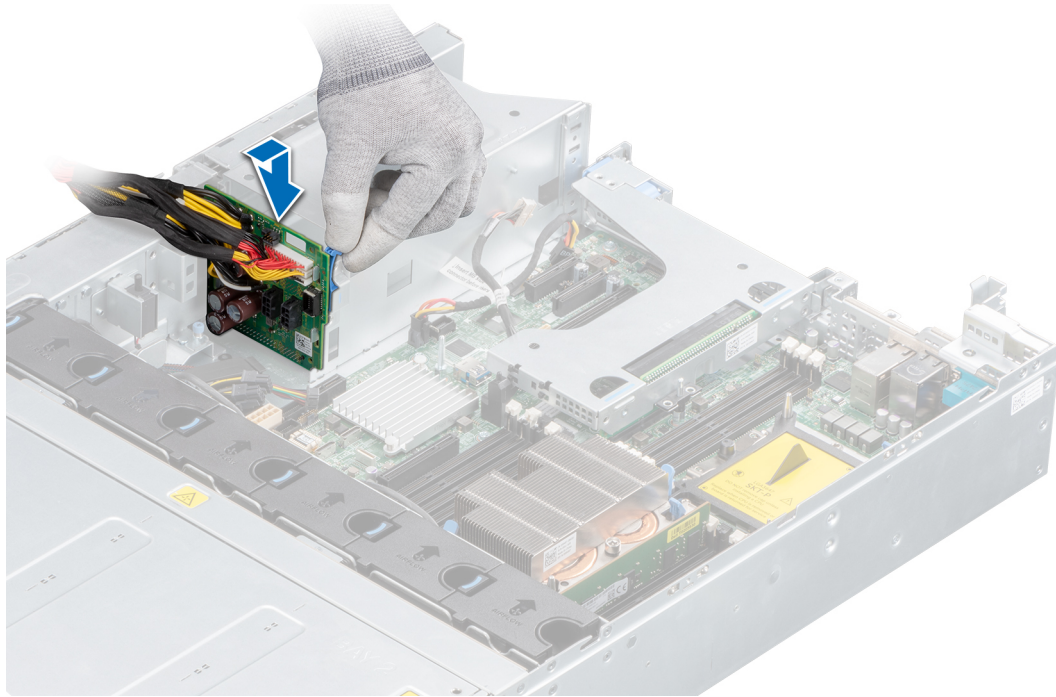

Figure 106. Installing power interposer board

Next steps

1. Connect all the cables to the PIB.
2. [Install the air shroud.](#)
3. Install the [system cover.](#)
4. Place the system into the rack. For more information, see the *Rail Installation Guide* at www.dell.com/xcseriesmanuals.
5. [Open the drive bays](#), install [all drives](#), and then [close the drive bays](#).
6. Install the [power supply units](#).
7. Follow the procedure listed in [After working inside your system](#).

System board

Removing the system board

Prerequisites

CAUTION: If you are using the Trusted Platform Module (TPM) with an encryption key, you may be prompted to create a recovery key during program or System Setup. Be sure to create and safely store this recovery key. If you replace this system board, you must supply the recovery key when you restart your system or program before you can access the encrypted data on your drives.

CAUTION: Do not attempt to remove the TPM plug-in module from the system board. Once the TPM plug-in module is installed, it is cryptographically bound to that specific system board. Any attempt to remove an installed TPM plug-in module breaks the cryptographic binding, and it cannot be re-installed or installed on another system board.

1. Follow the safety guidelines listed in [Safety Instructions](#).
2. Power off the system and all attached peripherals.
3. Disconnect the system from the electrical outlet, and disconnect the peripherals.
4. [Open the drive bays](#), remove [all drives](#), and then [close the drive bays](#).
5. Remove the [power supply units](#).
6. Remove the system from the rack and place it on an ESD work bench. For more information, see the *Rail Installation Guide* at www.dell.com/xcseriesmanuals.
7. [Remove the system cover](#).

8. Remove the following:

CAUTION: Do not lift the system board by holding a memory module, processor, or other components.

- a. Air shroud
- b. (if installed)
- c. All expansion cards and risers
- d. Internal PERC riser
- e. IDSDM/vFlash module
- f. Processors and heat sink modules
- g. Processors blanks (if installed)
- h. Memory modules and memory module blanks
- i. LOM riser card

Steps

- 1. Disconnect all cables from the system board.
- 2. Using a Phillips #2 screwdriver, remove nine screws securing the system board to the chassis.

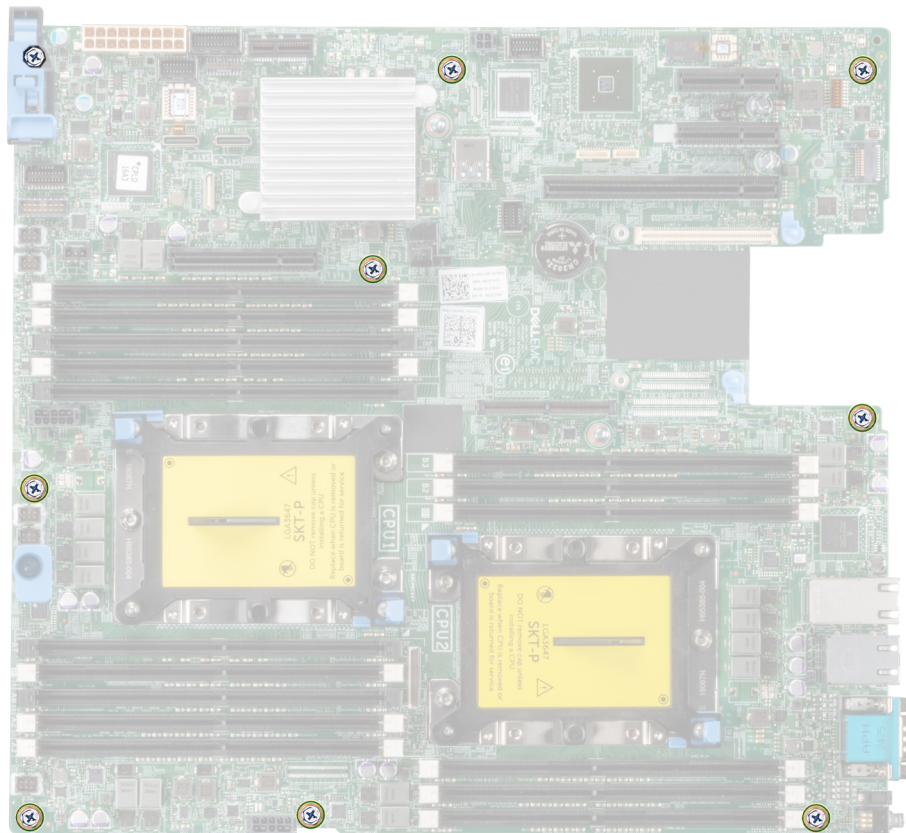

Figure 107. System board screws

3. Hold the system board holder, slightly lift the system board, and then slide it toward the front of the chassis.

CAUTION: To prevent damage to the processor socket when replacing a faulty system board, ensure that you cover the processor socket with the processor dust cover.

4. Incline the system board at an angle, and lift the system board out of the chassis.

CAUTION: Take care not to damage the system identification button while removing the system board from the chassis.

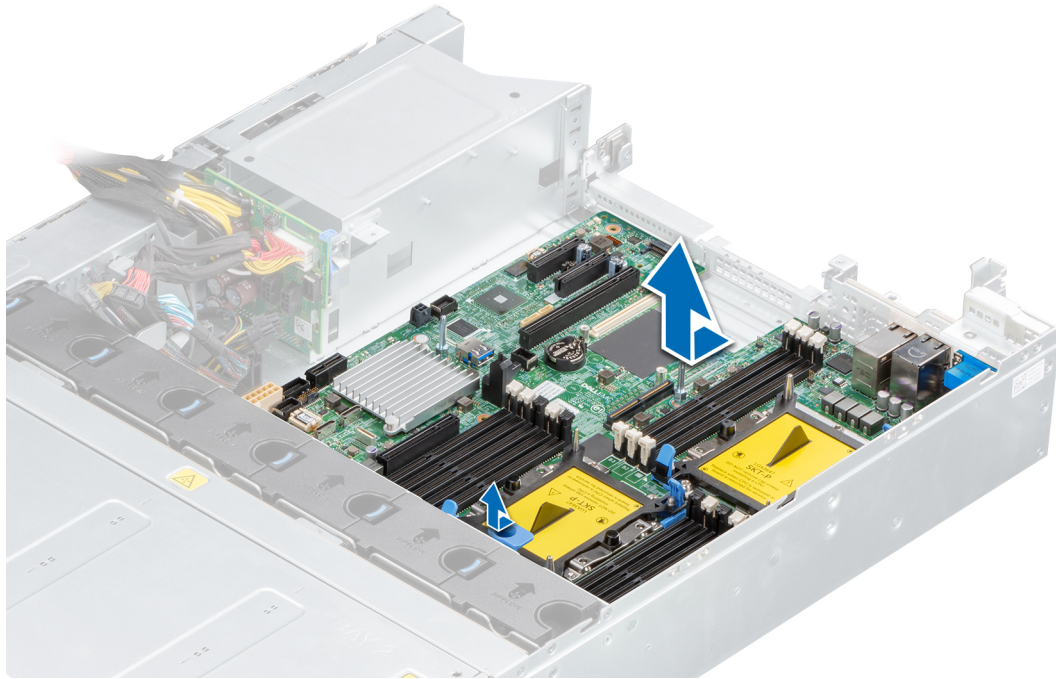

Figure 108. Removing the system board

Next steps

Replace or install the system board.

Installing the system board

Prerequisites

1. Follow the safety guidelines listed in [Safety Instructions](#).
2. Power off the system and all attached peripherals.
3. Disconnect the system from the electrical outlet, and disconnect the peripherals.
4. Ensure that all internal cables are routed correctly and connected, and no tools or extra parts are left inside the system.
5. [Open the drive bays](#), remove [all drives](#), and then [close the drive bays](#).
6. Remove the [power supply units](#).
7. Remove the system from the rack and place it on an ESD work bench. For more information, see the *Rail Installation Guide* at www.dell.com/xcseriesmanuals.
8. [Remove the system cover](#).
9. Remove the following:
 - a. [Air shroud](#)
 - b. (if installed)
 - c. [All expansion cards and risers](#)
 - d. [Internal PERC riser](#)
 - e. [IDSDM/vFlash module](#)
 - f. [Processors and heat sink modules](#)
 - g. Processors blanks (if installed)
 - h. [Memory modules and memory module blanks](#)
 - i. [LOM riser card](#)

Steps

1. Unpack the new system board.

 **CAUTION:** Do not lift the system board by holding a memory module, processor, or other components.

 **CAUTION:** Take care not to damage the system identification button while placing the system board into the chassis.

2. Holding the system board holder, push the system board toward the back of the system till it is seated.

CAUTION: To prevent damage to the processor socket when replacing a faulty system board, ensure that you cover the processor socket with the processor dust cover.

3. Using Phillips #2 screwdriver, tighten the screws to secure the system board to the chassis.

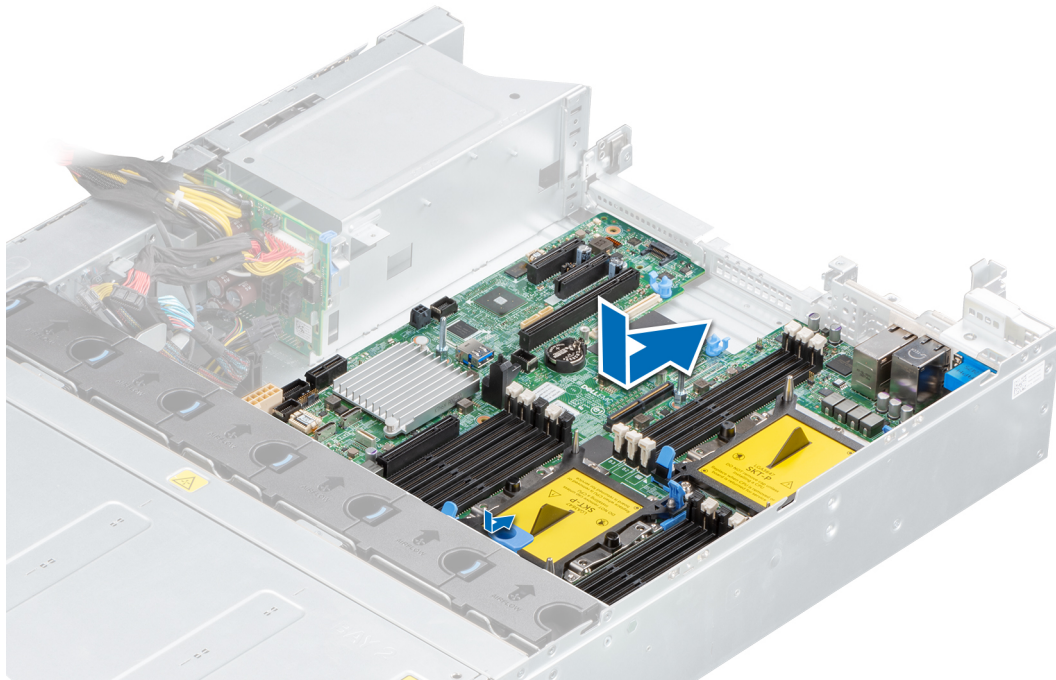

Figure 109. Installing system board

Next steps

1. Replace the following:

- a. Trusted platform module
- b. Internal PERC card
- c. iDRAC/vFlash module card
- d. All expansion cards and risers
- e. Processors and heat sink modules
- f. Processors blanks (if applicable)
- g. Memory modules and memory module blanks
- h. LOM riser card
- i. Air shroud

2. Reconnect all cables to the system board.

NOTE: Ensure that the cables inside the system are routed along the chassis wall and secured using the cable securing bracket.

3. Install the [system cover](#).
4. Place the system into the rack. For more information, see the *Rail Installation Guide* at www.dell.com/xcseriesmanuals.
5. [Open the drive bays](#), install [all drives](#), and then [close the drive bays](#).
6. Install the [power supply units](#).
7. Follow the procedure listed in [After working inside your system](#).
8. Boot the system.
9. Ensure that you:
 - a. Use the Easy Restore feature to restore the Service Tag. For more information, see the *Restoring the system using Easy Restore* section.
 - b. If the Service Tag is not backed up in the backup flash device, enter the Service Tag manually. For more information, see the *Manually update the Service Tag* section.
 - c. Update the BIOS and iDRAC versions.
 - d. Re-enable the Trusted Platform Module (TPM). For more information, see the *Re-enabling the TPM for BitLocker users* section.

10. Use Easy Restore to restore configuration.

If for any reason Easy Restore does not execute, you must manually update the following: Service Tag, iDRAC licenses, OEM ID or Personality Modules (if needed).

Refer to the *Manually update the Service Tag* page. Other configuration issues must also be done manually, for instance importing iDRAC License through iDRAC GUI.

11. Import your new or existing iDRAC Enterprise license.

For more information, see *Integrated Dell Remote Access Controller User's Guide*, at *iDRAC User's Guide* available at www.dell.com/idracmanuals.

12. Update the BIOS version.

NOTE:

- The RACADM command `RACADM sslresetcfg` is used to generate a new SSL certificate with service tag providing the unique Common Name (CN). If the certificate is not generated at time of service, inform the customer or technical support so they can follow up.
- RACADM must be installed. If RACADM is not installed, download and install the Dell DRAC Tools (Windows only). For more information on RACADM Command Line Interface, see the *RACADM Command Line Interface for DRAC* section.

13. Re-enable the Trusted Platform Module (TPM).

14. Turn off/exit manufacturing mode.

15. Let the system boot.

NOTE: If this system board replacement is for a Dell-branded product with a Windows embedded OS, do not exit manufacturing mode before you install the Dell Branded Embedded (DBE) Module.

NOTE: If this replacement is a non-OEM system board or if you have already installed the proper Identity Module: At the prompt press <A> to turn off manufacturing mode. For more information about manufacturing mode, see the *Troubleshooting Manufacturing Mode* section or consult Dell technical support for further assistance.

Trusted Platform Module

Upgrading the Trusted Platform Module

Prerequisites

1. Follow the safety guidelines listed [Safety Instructions](#).
2. Power off the system and all attached peripherals.
3. Disconnect the system from the electrical outlet, and disconnect the peripherals.
4. Ensure that all internal cables are routed correctly and connected, and no tools or extra parts are left inside the system.
5. [Open the drive bays](#), remove [all drives](#), and then [close the drive bays](#).
6. Remove the [power supply units](#).
7. Remove the system from the rack and place it on an ESD work bench. For more information, see the *Rail Installation Guide* at www.dell.com/xcseriesmanuals.
8. [Remove the system cover](#).
9. [Remove the air shroud](#).
10. If installed, [remove the risers](#).

NOTE:

- Ensure that your operating system supports the version of the TPM module being installed.
- Ensure that you download and install the latest BIOS firmware on your system.
- Ensure that the BIOS is configured to enable UEFI boot mode.

About this task

CAUTION: If you are using the Trusted Platform Module (TPM) with an encryption key, you may be prompted to create a recovery key during program or System Setup. Work with the customer to create and safely store this recovery key.

When replacing this system board, you must supply the recovery key when you restart your system or program before you can access the encrypted data on your hard drives.

CAUTION: Once the TPM plug-in module is installed, it is cryptographically bound to that specific system board. Any attempt to remove an installed TPM plug-in module breaks the cryptographic binding, the removed TPM cannot be reinstalled or installed on another system board.

Removing the TPM

Steps

1. Locate the TPM connector on the system board.

NOTE: To locate the TPM connector on the system board, see the [jumpers and connectors](#) section.

2. Press to hold the module down and remove the screw using the security Torx 8-bit shipped with the TPM module.
3. Slide the TPM module out from its connector.
4. Push the plastic rivet away from the TPM connector and rotate it 90° counterclockwise to release it from the system board.
5. Pull the plastic rivet out of its slot on the system board.

Installing the TPM

Steps

1. To install the TPM, align the edge connectors on the TPM with the slot on the TPM connector.
2. Insert the TPM into the TPM connector such that the plastic rivet aligns with the slot on the system board.
3. Press the plastic rivet until the rivet snaps into place.

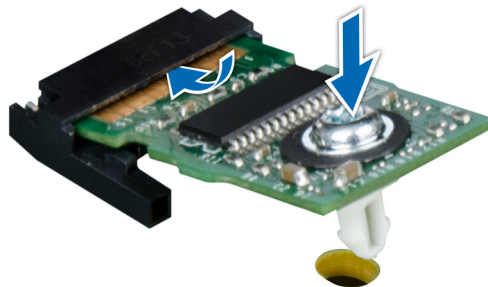

Figure 110. Installing the TPM

Next steps

1. If removed, [install the risers](#).
- 2.
3. [Install the air shroud](#).
4. Install the [system cover](#).
5. Place the system into the rack. For more information, see the *Rail Installation Guide* at www.dell.com/xcseriesmanuals.
6. [Open the drive bays](#), install [all drives](#), and then [close the drive bays](#).
7. Install the [power supply units](#).
8. Follow the procedure listed in [After working inside your system](#).

Initializing TPM for BitLocker users

Steps

Initialize the TPM.

For more information, see <https://technet.microsoft.com/en-us/library/cc753140.aspx>.

The **TPM Status** changes to **Enabled, Activated**.

Initializing the TPM 1.2 for TXT users

Steps

1. While booting your system, press F2 to enter System Setup.
2. On the **System Setup Main Menu** screen, click **System BIOS > System Security Settings**.
3. From the **TPM Security** option, select **On with Pre-boot Measurements**.
4. From the **TPM Command** option, select **Activate**.
5. Save the settings.
6. Restart your system.
7. Enter **System Setup** again.
8. On the **System Setup Main Menu** screen, click **System BIOS > System Security Settings**.
9. From the **Intel TXT** option, select **On**.

Initializing the TPM 2.0 for TXT users

Steps

1. While booting your system, press F2 to enter System Setup.
2. On the **System Setup Main Menu** screen, click **System BIOS > System Security Settings**.
3. From the **TPM Security** option, select **On**.
4. Save the settings.
5. Restart your system.
6. Enter **System Setup** again.
7. On the **System Setup Main Menu** screen, click **System BIOS > System Security Settings**.
8. Select the **TPM Advanced Settings** option.
9. From the **TPM2 Algorithm Selection** option, select **SHA256**, then go back to **System Security Settings** screen.
10. On the **System Security Settings** screen, from the **Intel TXT** option, select **On**.
11. Save the settings.
12. Restart your system.

Cable chain assembly

Removing cable chain assembly

Prerequisites

1. Follow the safety guidelines listed in [Safety Instructions](#).
2. Power off the system and all attached peripherals.
3. Disconnect the system from the electrical outlet, and disconnect the peripherals.
4. [Open the drive bays](#), remove **all drives**, and then [close the drive bays](#).
5. Remove the [power supply units](#).
6. Remove the system from the rack and place it on an ESD work bench. For more information, see the *Rail Installation Guide* at www.dell.com/xcseriesmanuals.
7. [Remove the system cover](#).
8. If installed, [remove the front bezel](#).
9. Remove the following:
 - a. [Drive bay 1 backplane bracket](#).
 - b. [Drive bay 2 backplane bracket](#).
 - c. [Air shroud](#).

- d. Intrusion switch.
- e. Internal PERC riser.
- f. Memory modules for processor 1.
- g. PIB.

10. Disconnect all cables connected to the cable chain assembly from the backplanes and the system board.

Steps

1. Using a Phillips #1 screwdriver, remove all the screws securing the support bar and lift it away from the system.
2. Remove the screws connecting the cable chain and the bay 2 backplane bracket.
3. Remove the screws securing the cable chain top cover, and disengage it from the guiding pins and lift it away from the system.

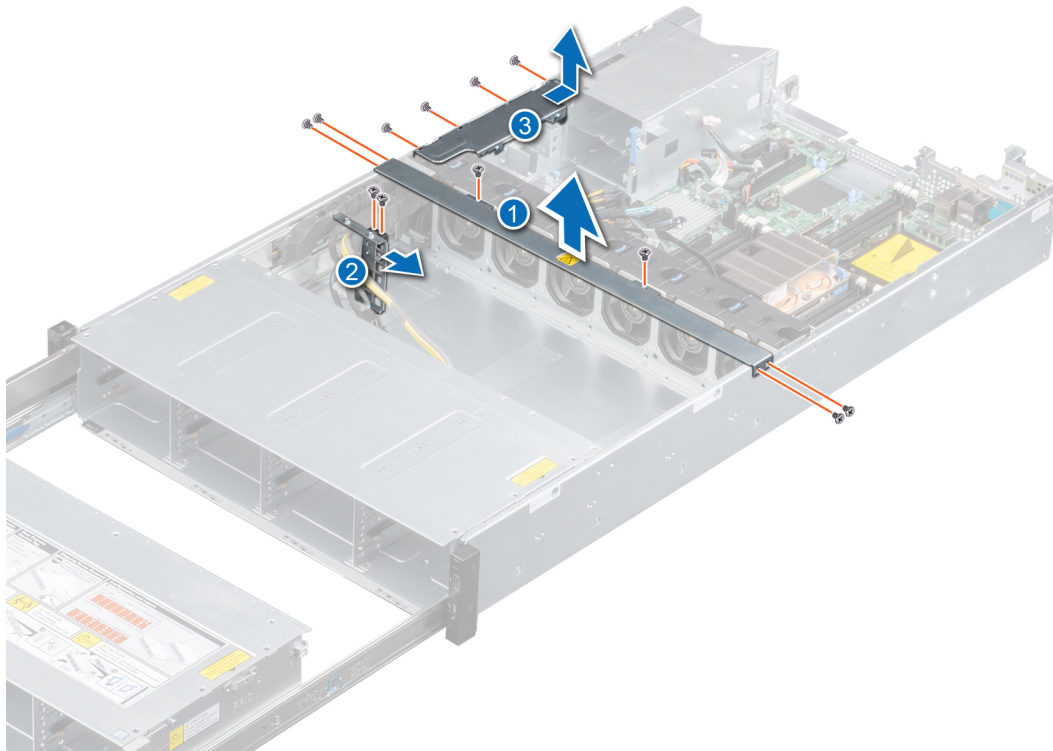

Figure 111. Removing the support bar, cable chain top cover and disconnecting the bay 2 backplane bracket from the cable chain assembly.

4. Loosen the captive screw for the cable chain side cover and disengage it from the guiding pins below and lift it away from the system.
5. Slide the left side of the system, partially off the table, until the bottom screws for the cable chain base bracket are visible and remove the screws.

CAUTION: Make sure the system is placed on a work bench before working for this step, as tilting the system or placing it on its side on the ground, would risk stressing the chassis or toppling the system, causing damage to components.

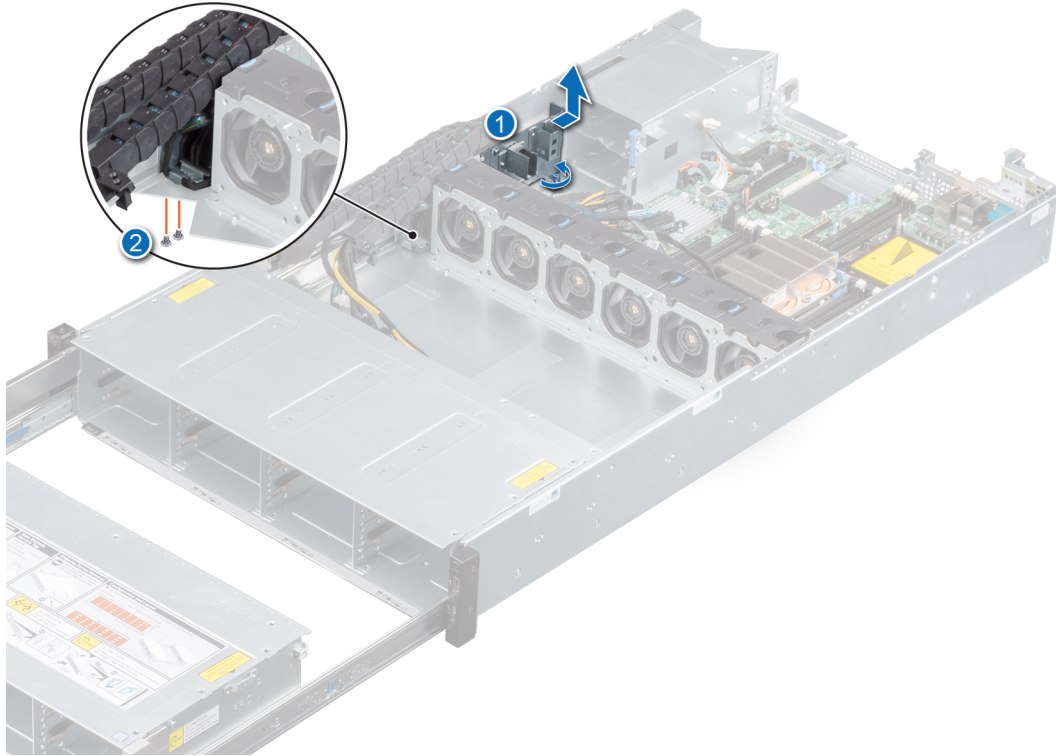

Figure 112. Removing screws for cable chain base bracket and cable chain side cover

6. Slide drive bay 2 towards the rear of the system until the screws for the left and right white plastic rail stops are visible and remove them.
7. Disconnect the left control panel cable from the system board and release it from the cable chain base bracket.

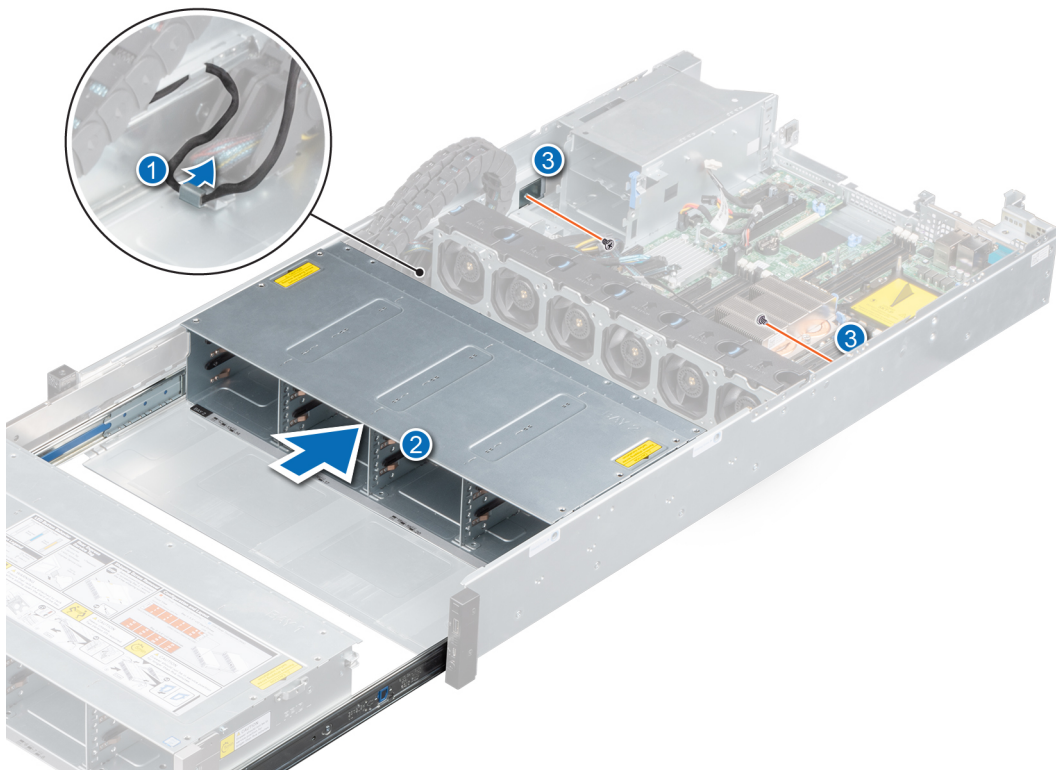

Figure 113. Removing the left and right rail white plastic rail stops

8. Remove the screws connecting the cable chain rail to the chassis.
9. Extend the drive bays all the way out of the bay area, until there is a gap to remove the cable chain rail.
10. Lift the cable chain assembly out of the system.

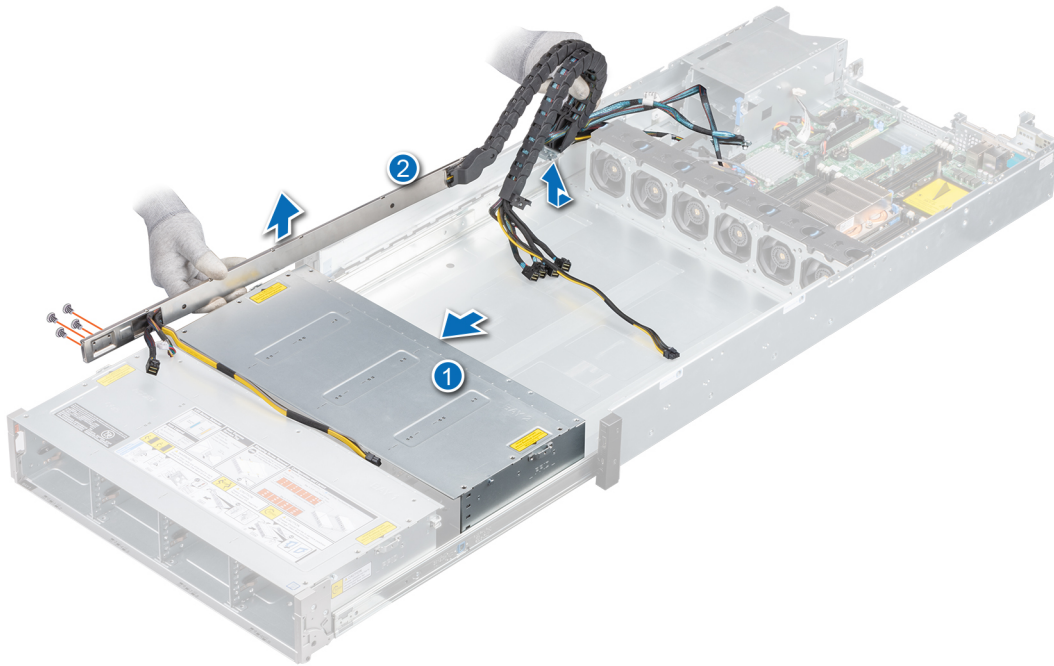

Figure 114. Removing the cable chain assembly from the system

Next steps

Replace the cable chain assembly.

Installing the cable chain assembly

Prerequisites

1. Follow the safety guidelines listed in [Safety Instructions](#).
2. Power off the system and all attached peripherals.
3. Disconnect the system from the electrical outlet, and disconnect the peripherals.
4. Ensure that all internal cables are routed correctly and connected, and no tools or extra parts are left inside the system.
5. [Open the drive bays](#), remove **all drives**, and then [close the drive bays](#).
6. Remove the [power supply units](#).
7. If installed, [remove the front bezel](#).
8. Remove the system from the rack and place it on an ESD work bench. For more information, see the *Rail Installation Guide* at www.dell.com/xcseriesmanuals.
9. [Remove the system cover](#).
10. Remove the following:
 - a. [Drive bay 1 backplane bracket](#).
 - b. [Drive bay 2 backplane bracket](#).
 - c. [Air shroud](#).
 - d. [Intrusion switch](#).
 - e. [Internal PERC riser](#).
 - f. [Memory modules for processor 1](#).
 - g. [PIB](#).
11. Disconnect all cables connected to the cable chain assembly from the backplanes and the system board.

Steps

1. Place the cable chain assembly in the system and route the left control panel cable through the cable chain base bracket.

- Using a Phillips #1 screwdriver, replace the screws for the cable chain rail after aligning it to the chassis and align the cable chain assembly to the bottom screw holes.

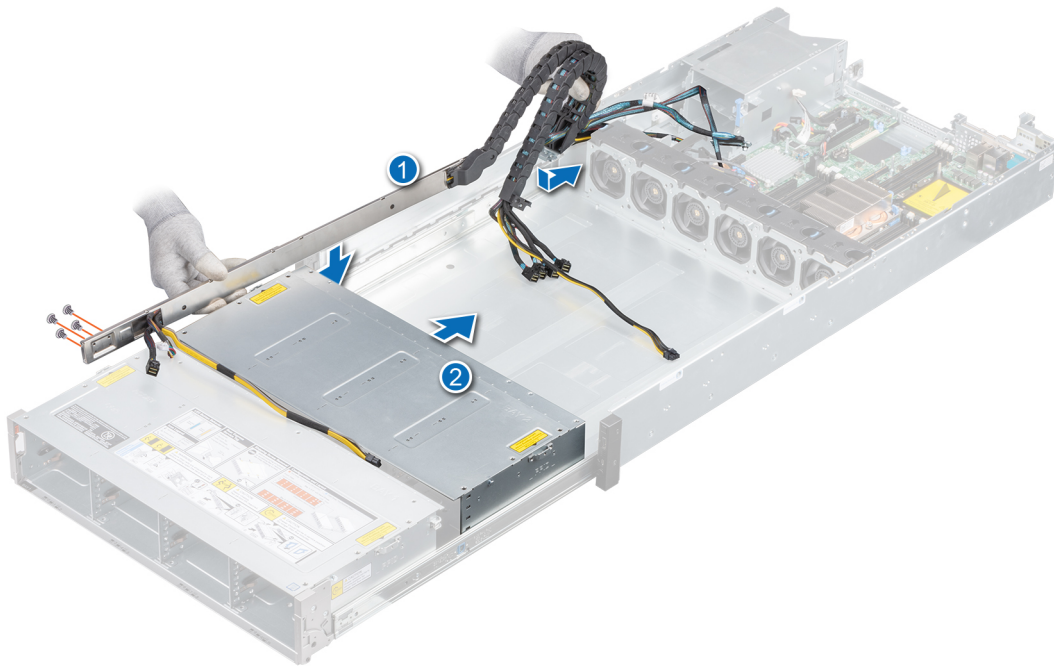

Figure 115. Placing the cable chain assembly in the system

- Slide the left side of the system, partially off the table, until the bottom screws holes for the cable chain base bracket are visible and replace the screws.
- Align the cable chain side cover to the guiding pins on the system and tighten the captive screw.

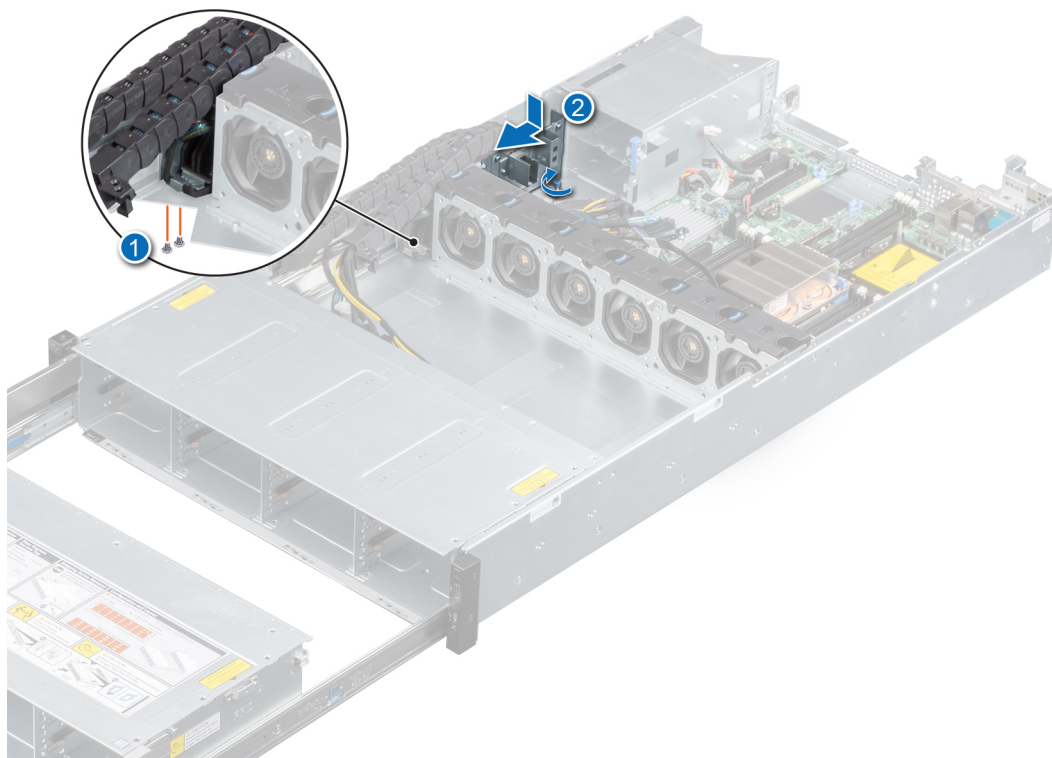

Figure 116. Replacing the cable chain side cover and the bottom screws

- Replace the screws for the left and right white plastic rail stops.

NOTE: Make sure the left control panel cable is routed through the cable chain base bracket and connect the cable connector to the system board connector.

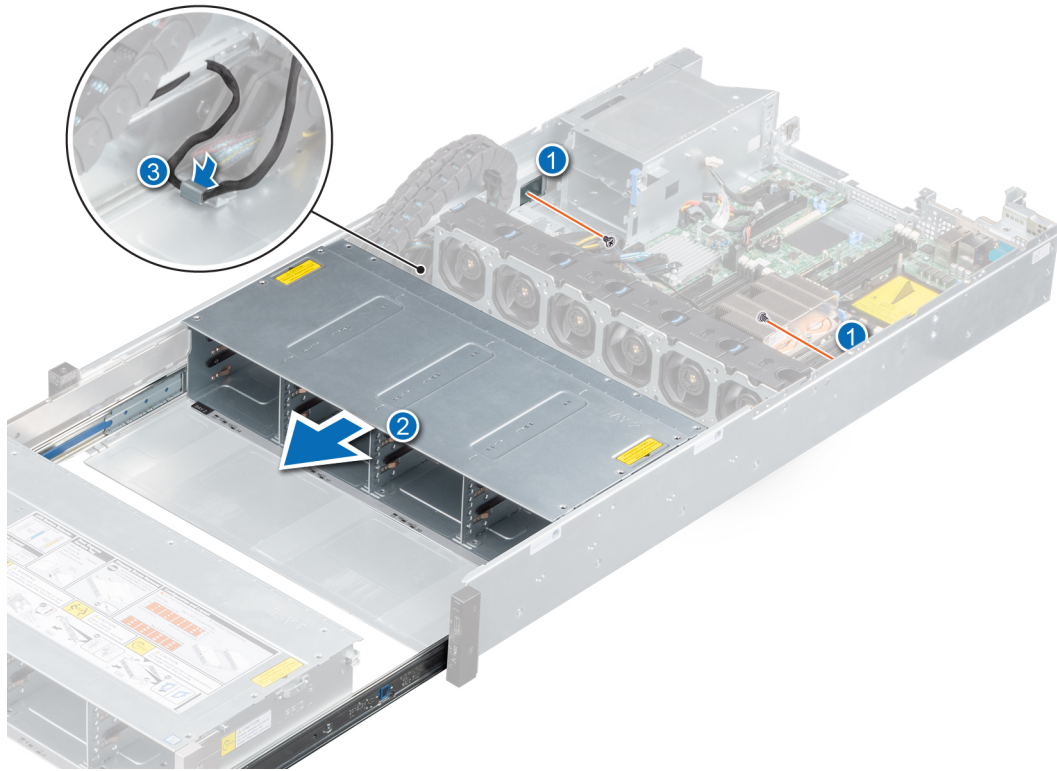

Figure 117. Replacing the screws for the left and right white plastic rail stops

6. Align the support bar to the chassis and replace all the screws.
7. Align the bay 2 backplane bracket to the cable chain assembly and replace the screws.
8. Align the cable chain top cover to the guiding pins and replace all the screws.

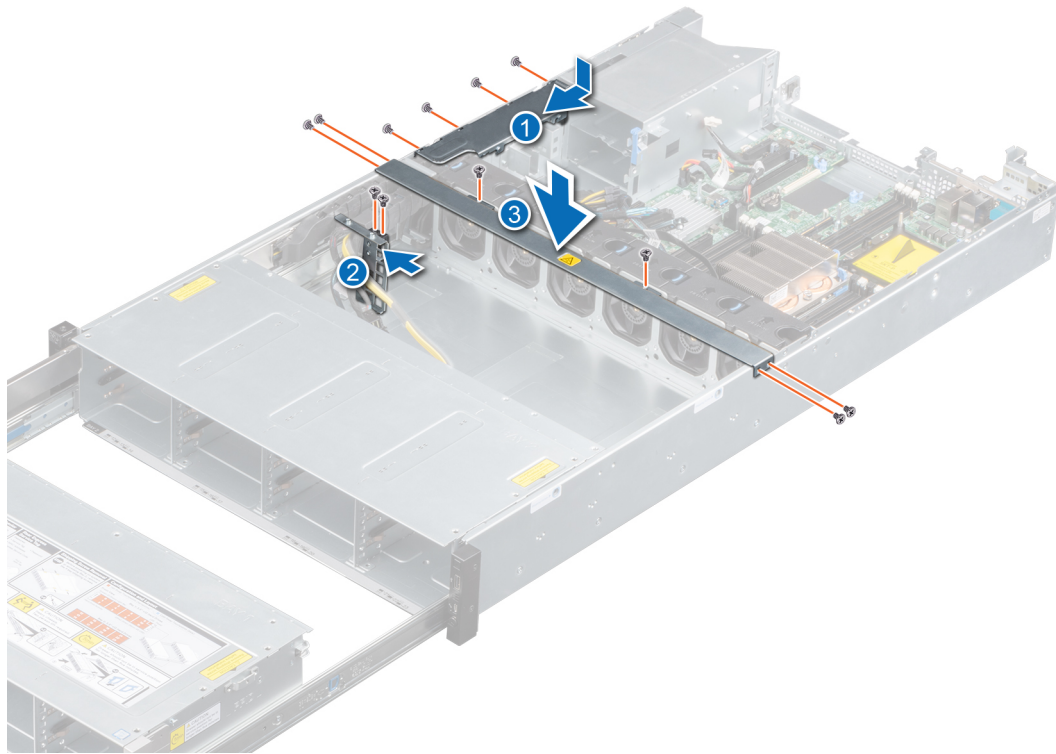

Figure 118. Replacing the support bar, cable chain top cover and connecting the bay 2 backplane bracket from the cable chain assembly.

Next steps

1. Replace the following:
 - a. [PIB](#).
 - b. [Memory modules for processor 1](#).
 - c. [Internal PERC card](#).
 - d. [Intrusion switch](#).
 - e. [Air shroud](#).
 - f. [Drive bay 1 bracket](#).
 - g. [Drive bay 2 bracket](#).
 - h. Connect all the cables to the backplane and system board.
2. Install the [system cover](#).
3. Place the system into the rack. For more information, see the *Rail Installation Guide* at www.dell.com/xcseriesmanuals.
4. Install the [power supply units](#).
5. [Open the drive bays](#), install [all drives](#), and then [close the drive bays](#).
6. If removed, [install the front bezel](#).
7. Follow the procedure listed in [After working inside your system](#).

Control panel

Removing the left control panel

Prerequisites

1. Follow the safety guidelines listed in [Safety Instructions](#).
2. Power off the system and all attached peripherals.
3. Disconnect the system from the electrical outlet, and disconnect the peripherals.
4. [Open the drive bays](#), remove [all drives](#), and then [close the drive bays](#).
5. Remove the [power supply units](#).

6. Remove the system from the rack and place it on an ESD work bench. For more information, see the *Rail Installation Guide* at www.dell.com/xcseriesmanuals.
7. [Remove the system cover](#).
8. If installed, [remove the front bezel](#)
9. Remove the [cable chain assembly](#).
10. Disconnect the control panel cable from the system board connector.

Steps

1. Remove the cable from the left ear cable channel.

NOTE: Ensure that you note the routing of the cables as you remove them from the system board. You must route the cables properly when you replace them to prevent the cables from being pinched or crimped.

2. Using a Phillips #1 screwdriver, remove the screws that secure the left control panel assembly to the system.
3. Holding by the sides, remove the left control panel assembly away from the system.

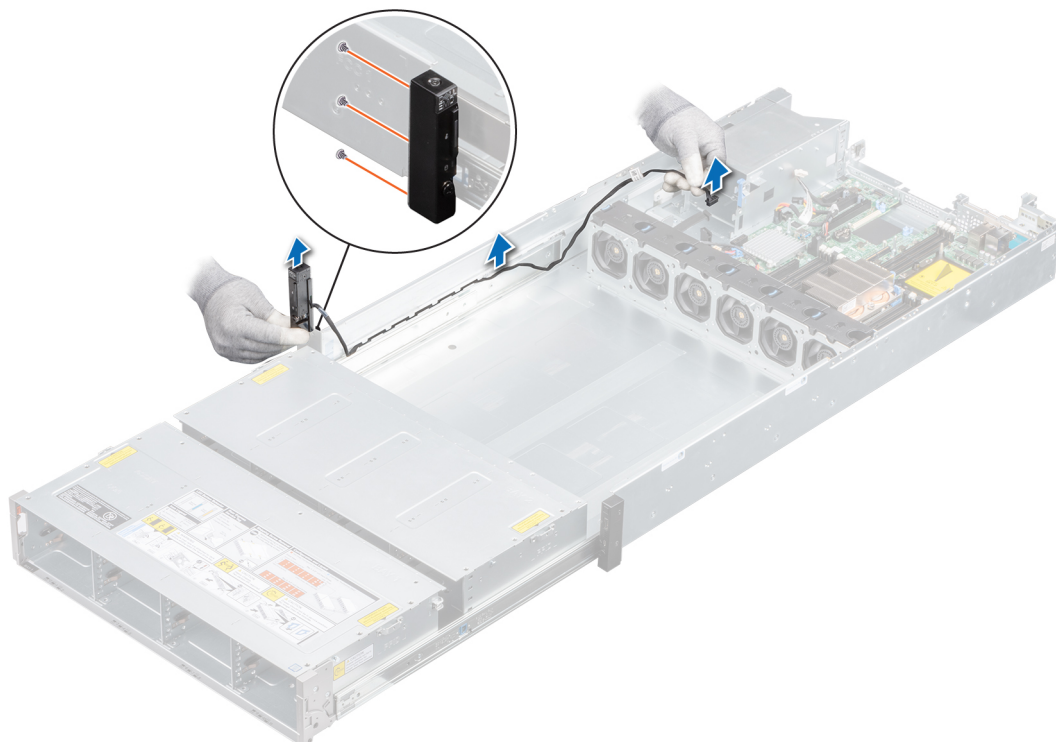

Figure 119. Removing the left control panel

Next steps

[Replace the left control panel.](#)

Installing the left control panel

Prerequisites

1. Follow the safety guidelines listed in [Safety Instructions](#).
2. Power off the system and all attached peripherals.
3. Disconnect the system from the electrical outlet, and disconnect the peripherals.
4. Ensure that all internal cables are routed correctly and connected, and no tools or extra parts are left inside the system.
5. If installed, [remove the front bezel](#).
6. [Open the drive bays](#), remove **all drives**, and then [close the drive bays](#).
7. Remove the [power supply units](#).
8. Remove the system from the rack and place it on an ESD work bench. For more information, see the *Rail Installation Guide* at www.dell.com/xcseriesmanuals.
9. [Remove the system cover](#).

10. Remove the [cable chain assembly](#).

Steps

1. Align the left control panel assembly with the control panel slot on the chassis and using Phillips #1 screwdriver, replace the screws to secure the left control panel assembly to the chassis.
2. Route the left control panel cable through the cable channel of the system.



Figure 120. Installing the left control panel

3. Connect the control panel cable to the system board connector.

Next steps

1. Install the [cable chain assembly](#).
2. [Close the drive bays](#).
3. Place the system into the rack. For more information, see the *Rail Installation Guide* at www.dell.com/xcseriesmanuals.
4. Install the [power supply units](#).
5. [Open the drive bays](#), install [all drives](#), and then [close the drive bays](#).
6. If removed, [install the front bezel](#).
7. Follow the procedure listed in [After working inside your system](#).

Removing the right control panel

Prerequisites

1. Follow the safety guidelines listed in [Safety Instructions](#)
2. Power off the system and all attached peripherals.
3. Ensure that all internal cables are routed correctly and connected, and no tools or extra parts are left inside the system.
4. [Open the drive bays](#), remove [all drives](#), and then [close the drive bays](#).
5. Remove the [power supply units](#).
6. Remove the system from the rack and place it on an ESD work bench. For more information, see the *Rail Installation Guide* at www.dell.com/xcseriesmanuals.
7. If installed, [remove the front bezel](#)
8. [Remove the system cover](#).
9. [Remove the air shroud](#).

10. Remove the internal PERC riser.
11. Disconnect all cables connected to the system board.

Steps

1. Open the blue release clip and disconnect the right control panel cable from the system board.
2. Release the cable from the right rack ear cable clips and push the cable connector through the side of the fan cage.
i **NOTE: Ensure that you note the routing of the cables as you remove them from the system board. Route the cables properly when you replace them to prevent the cables from being pinched or crimped.**
3. Push bay 2 into the chassis and release the cable from the right rack ear cable clips.

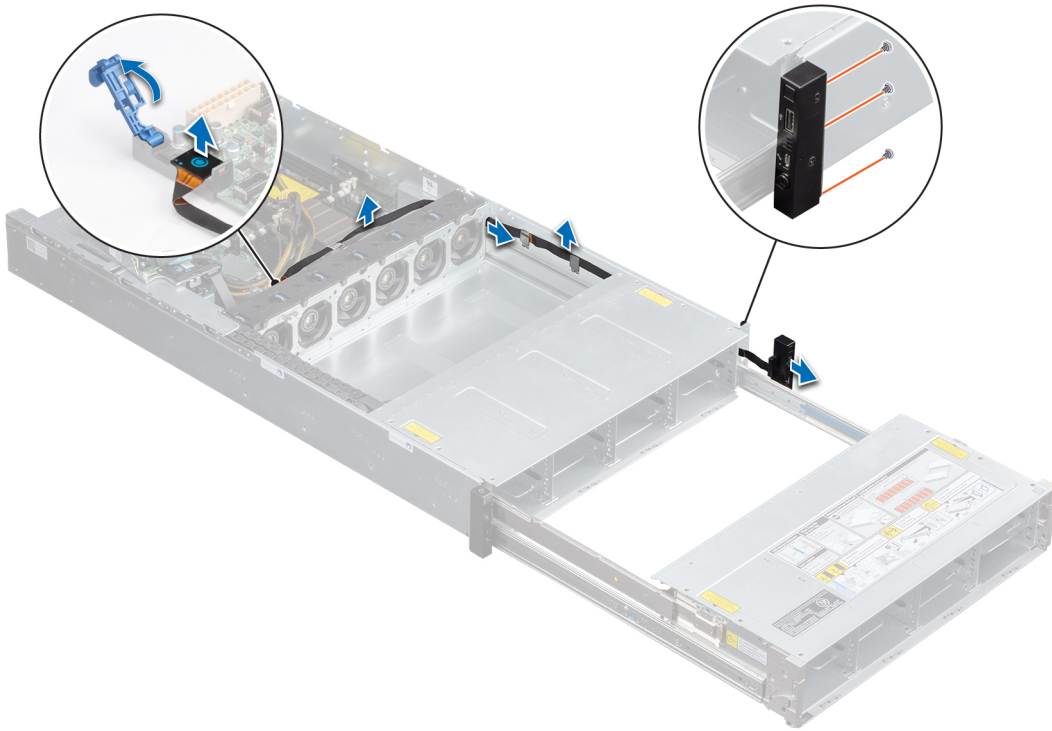

Figure 121. Removing the control panel cable

4. Using Phillips #1 screwdriver, remove the screws that secure the right control panel assembly to the system.
5. Holding by the sides, remove the right control panel assembly away from the system.

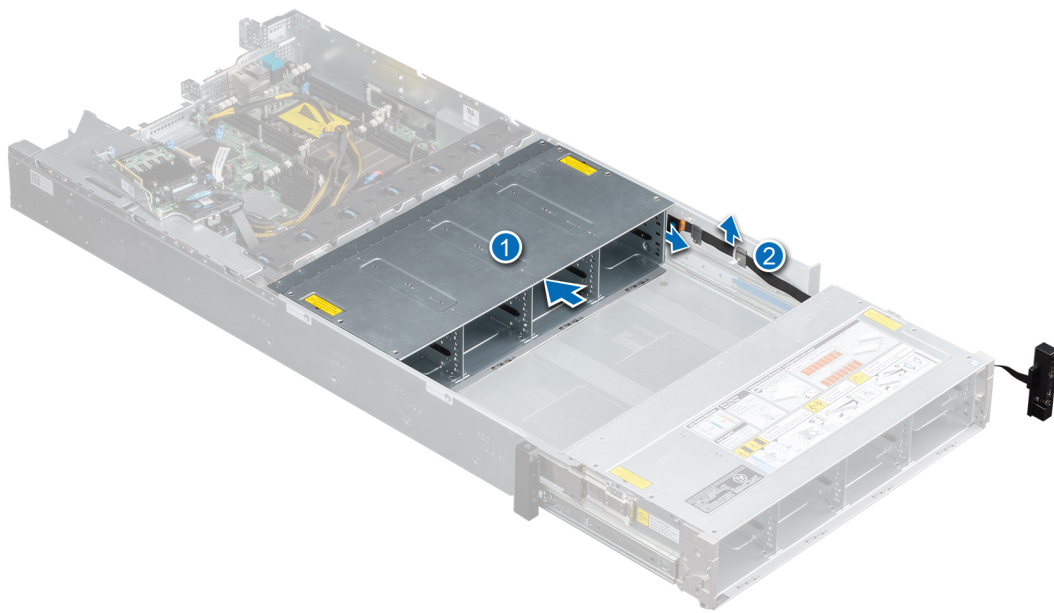

Figure 122. Removing the right control panel

Next steps

Replace the right control panel.

Installing the right control panel

Prerequisites

1. Follow the safety guidelines listed in [Safety Instructions](#).
2. Power off the system and all attached peripherals.
3. Ensure that all internal cables are routed correctly and connected, and no tools or extra parts are left inside the system.
4. [Open the drive bays](#), remove [all drives](#), and then [close the drive bays](#).
5. Remove the [power supply units](#).
6. Remove the system from the rack and place it on an ESD work bench. For more information, see the *Rail Installation Guide* at www.dell.com/xcseriesmanuals.
7. [Remove the system cover](#).
8. [Remove the air shroud](#).
9. [Remove the internal PERC card](#).

Steps

1. Route the control panel cable through the right control panel cable clips and push the cable connector through the side of bay 2.

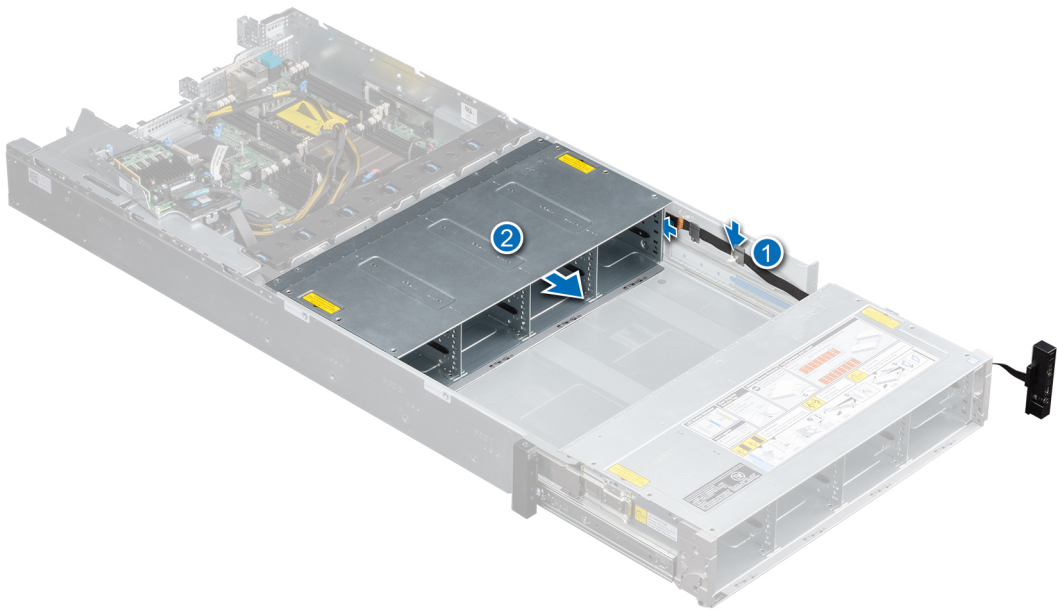

Figure 123. Aligning the right control panel cable

2. Extend bay 2 and pull the cable through the side of the bay.
3. Route the cable through the right control panel cable clip and push the cable connector through the side of the fan cage.
4. Connect the control panel cable to the connector on the system board and close the blue release clip.
5. Using a Phillips #1 screwdriver, tighten the screws to secure the right control panel assembly to the system.

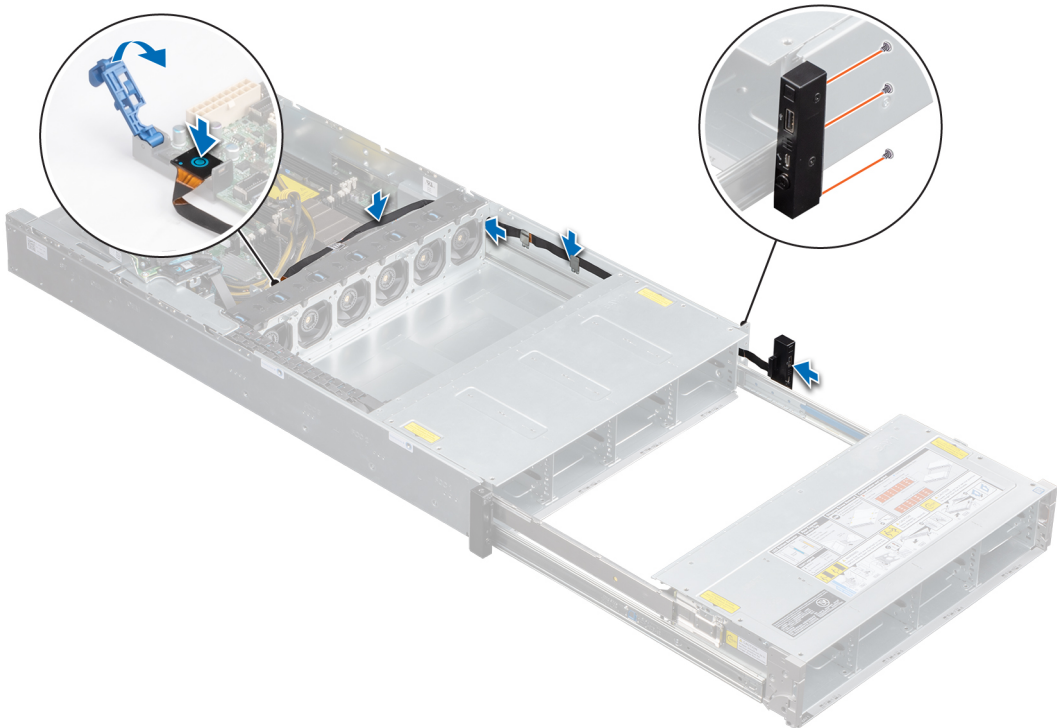

Figure 124. Installing the right control panel

Next steps

1. [Install the internal PERC card.](#)
2. [Install the air shroud.](#)
3. [Close the drive bays.](#)
4. [Install the system cover.](#)
5. Place the system into the rack. For more information, see the *Rail Installation Guide* at www.dell.com/xcseriesmanuals.
6. [Install the power supply units.](#)
7. [Open the drive bays](#), install [all drives](#), and then [close the drive bays](#).
8. If removed, [install the front bezel](#).
9. Follow the procedure listed in [After working inside your system](#).

Jumpers and connectors

This topic provides specific information about the jumpers. It also provides some basic information about jumpers and switches and describes the connectors on the various boards in the system. Jumpers on the system board help to disable the system and setup passwords. You must know the connectors on the system board to install components and cables correctly.

Topics:

- [System board connectors](#)
- [System board jumper settings](#)
- [Disabling forgotten password](#)

System board connectors

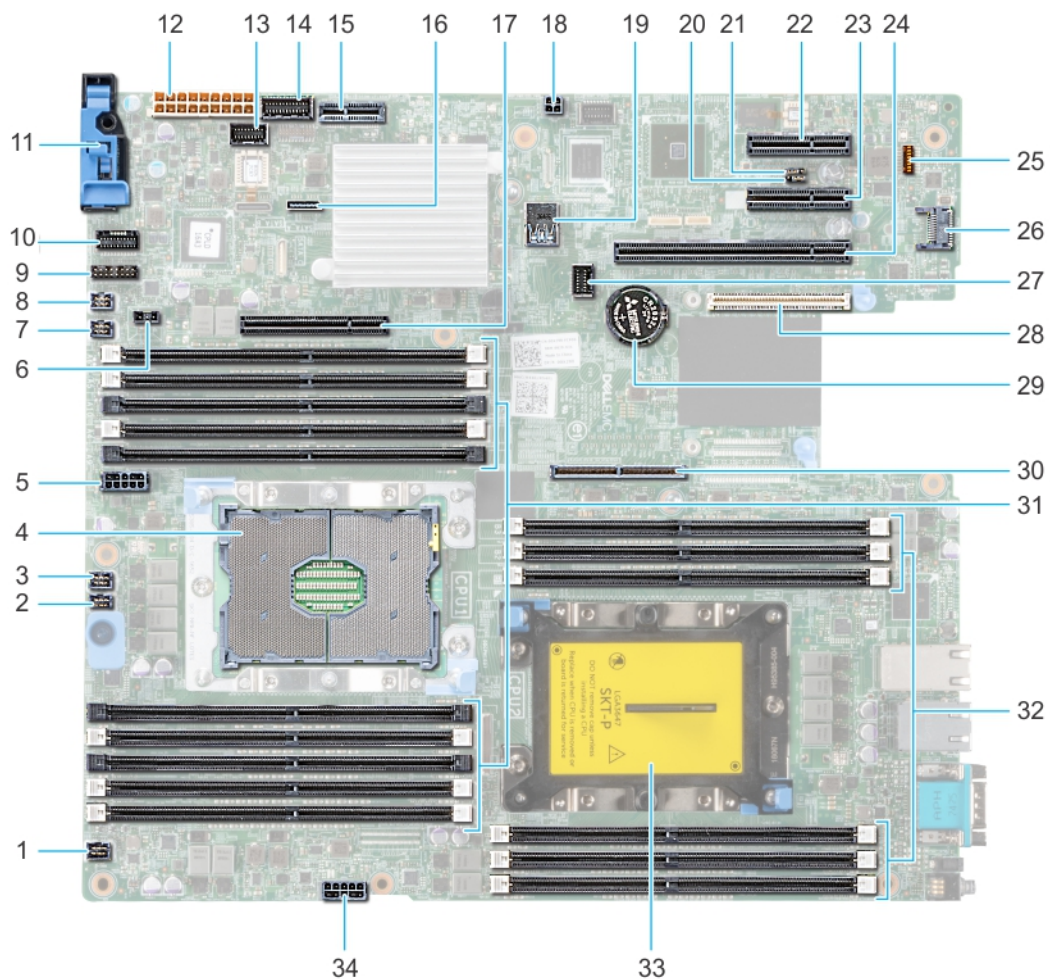

Figure 125. System board jumpers and connectors

Table 10. System board jumpers and connectors

Item	Connector	Description
1.	FAN6	Fan6 connector
2.	FAN5	Fan5 connector



Item	Connector	Description
3.	FAN4	Fan4 connector
4.	CPU1	Processor socket 1
5.	CPU1_PWR_CONN(P2)	CPU1 power connector
6.	J_INTRU	Intrusion switch connector
7.	FAN3	Fan3 connector
8.	FAN2	Fan2 connector
9.	J_BP_SIG1	Backplane signal connector 1
10.	LFT_CP_CONN	Left control panel connector
11.	RGT_CP_CONN	Right panel connector
12.	SYS_PWR_CONN(P1)	System power connector
13.	J_PIB_SIG1	Power interface board signal connector 1
14.	J_PIB_SIG2	Power interface board signal connector 2
15.	J_ACE	Internal Dual SD Module
16.	J_SATA_A1	Internal SATA A connector
17.	PCIE_G3_X8(CPU1)	Internal PERC controller connector
18.	J_REAR_BP_PWR1	ODD power connector
19.	INT_USB_3.0	USB connector
20.	NVRAM_CLR	Clear NVRAM
21.	PWRD_EN	Reset BIOS password
22.	SLOT6	PCIe slot 6
23.	SLOT5	PCIe slot 5
24.	SLOT4	PCIe slot 4
25.	LEDs (7)	System board diagnostic LED indicators
26.	J_TPM_MODULE	TPM module connector
27.	J_BP_SIG0	Backplane signal connector
28.	J_MEZZ_A1	LOM riser card connector
29.	BATTERY	Battery connector
30.	PCIE_G3_X16(CPU1)	Riser 1 connector
31.	A6, A5, A10, A4, A9, A7, A1, A8, A2, A3	Memory module sockets
32.	B3, B2, B1, B4, B5, B6	Memory module sockets
33.	CPU2	Processor 2 dust cover
34.	CPU2_PWR_CONN(P3)	Processor 2 power connector

System board jumper settings

For information on resetting the password jumper to disable a password, see the [Disabling forgotten password](#) section.

Table 11. System board jumper settings

Jumper	Setting	Description
PWRD_EN	 2 4 6 (default)	The BIOS password feature is enabled.

Jumper	Setting	Description
NVRAM_CLR	 2 4 6	The BIOS password feature is disabled. iDRAC local access is unlocked at next AC power cycle. iDRAC password reset is enabled in F2 iDRAC settings menu.
	 1 3 5 (default)	The BIOS configuration settings are retained at system boot.
	 1 3 5	The BIOS configuration settings are cleared at system boot.

Disabling forgotten password

The software security features of the system include a system password and a setup password. The password jumper enables or disables password features and clears any password(s) currently in use.

Prerequisites

CAUTION: Many repairs may only be done by a certified service technician. You should only perform troubleshooting and simple repairs as authorized in your product documentation, or as directed by the online or telephone service and support team. Damage due to servicing that is not authorized by Dell is not covered by your warranty. Read and follow the safety instructions that are shipped with your product.

Steps

1. Power off the system, including any attached peripherals, and disconnect the system from the electrical outlet.
2. Remove the system cover.
3. Move the jumper on the system board jumper from pins 2 and 4 to pins 4 and 6.
4. Install the system cover.

The existing passwords are not disabled (erased) until the system boots with the jumper on pins 4 and 6. However, before you assign a new system and/or setup password, you must move the jumper back to pins 2 and 4.

NOTE: If you assign a new system and/or setup password with the jumper on pins 4 and 6, the system disables the new password(s) the next time it boots.

5. Reconnect the system to its electrical outlet and power on the system, including any attached peripherals.
6. Power off the system, including any attached peripherals, and disconnect the system from the electrical outlet.
7. Remove the system cover.
8. Move the jumper on the system board jumper from pins 4 and 6 to pins 2 and 4.
9. Install the system cover.
10. Reconnect the system to its electrical outlet and power on the system, including any attached peripherals.
11. Assign a new system and/or setup password.

Technical specifications

The technical and environmental specifications of your system are outlined in this section.

Topics:

- Chassis dimensions
- System weight
- Processor specifications
- Supported operating systems
- PSU specifications
- Cooling fans specifications
- System battery specifications
- PCIe Expansion card riser specifications
- Memory specifications
- Storage controller specifications
- Drives
- Ports and connectors specifications
- Video specifications
- Environmental specifications

Chassis dimensions

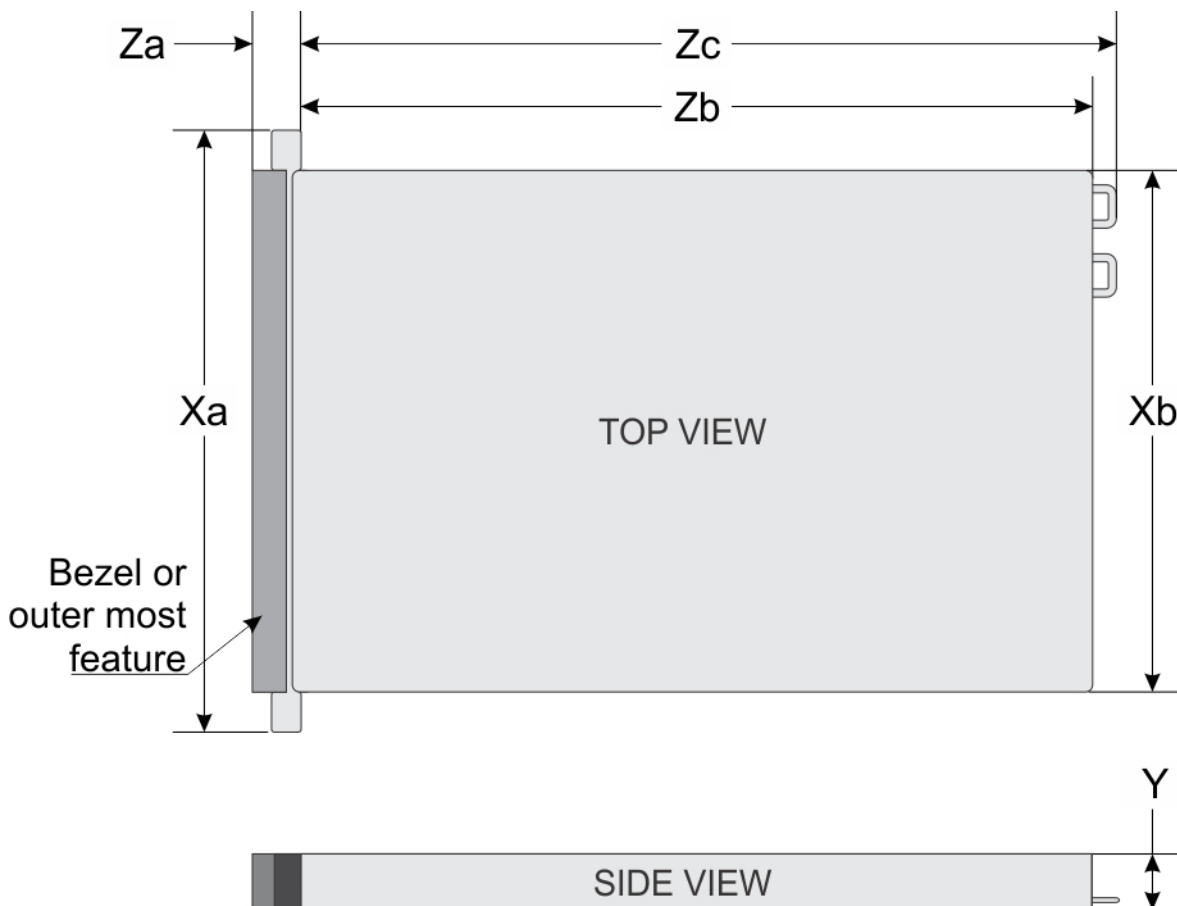

Figure 126. Chassis dimensions

Table 12. Dell EMC XC740xd2 chassis dimensions

Xa	Xb	Y	Za	Zb*	Zc
482.0 mm (18.9 inches)	448.0 mm (17.63 inches)	86.8 mm (3.41 inches)	With bezel: 35.93 mm (1.41 inches) Without bezel: 22.0 mm (0.866 inches)	810.264 mm (31.9 inches)	844.826mm (33.260 inches)

NOTE: * - Zb refers to the nominal rear wall external surface, where the system board I/O connectors are located.

System weight

Table 13. Dell EMC XC740xd2 system weight

System configuration	Maximum weight (with all drives/SSDs)
24+2 x 3.5-inch drives	43.2 kg (95.24 lb)

Processor specifications

Table 14. Dell EMC XC740xd2 processor specifications

Supported processor	Number of supported processors
Intel Xeon Scalable Processor	Two

Supported operating systems

The Dell EMC XC740xd2 supports the following operating systems:

- Nutanix AHV

NOTE: For more information, go to www.dell.com/ossupport.

NOTE: For more information about the specific versions and additions, go to <https://www.dell.com/support/home/Drivers/SupportedOS/XC-740xd2>.

PSU specifications

The Dell EMC XC740xd2 system supports up to two AC or DC power supply units (PSUs).

Table 15. PSU specifications

PSU	Class	Heat dissipation (maximum)	Frequency	Voltage	AC		DC	Current
					High line 100–240 V	Low line 100–120 V		
1100 W AC	Platinum	4100 BTU/hr	50/60 Hz	100–240 V AC, autoranging	1100 W	1050 W	NA	12 A–6.5 A
1100 W Mixed Mode HVDC (for China and Japan only)	Platinum	4416 BTU/hr	50/60 Hz	100–240 V AC, autoranging	1100 W	NA	NA	12 A–6.5 A
	Platinum	4416 BTU/hr	NA	200–380 V DC, autoranging	NA	NA	1100 W	6.4 A–3.2 A

NOTE: Heat dissipation is calculated using the PSU wattage rating.

NOTE: This system is also designed to connect to the IT power systems with a phase-to-phase voltage not exceeding 240 V.

Cooling fans specifications

The Dell EMC XC740xd2 system supports up to six high performance cooling fans.

NOTE: When selecting or upgrading the system configuration, to ensure optimum power utilization, verify the system power consumption with the Dell Energy Smart Solution Advisor available at Dell.com/ESSA.

Table 16. Dell EMC XC740xd2 fan support matrix

Storage	PSU type	Processor count	Fan 1	Fan 2	Fan 3	Fan 4	Fan 5	Fan 6
24+2 x 3.5-inch or 24 x 3.5-inch.	Redundant PSUs only	1	Required	Required	Required	Required	Required	Required
		2	Required	Required	Required	Required	Required	Required

NOTE: Each fan is listed in the systems management software, referenced by the respective fan number. If there is a problem with a particular fan, you can easily identify and replace the proper fan by noting the fan numbers on the cooling fan assembly.

System battery specifications

The Dell EMC XC740xd2 system supports CR 2032 3.0-V lithium coin cell system battery.

PCIe Expansion card riser specifications

The Dell EMC XC740xd2 system supports up to three PCI express (PCIe) generation 3 expansion cards that can be installed on the system board and expansion card risers..

Table 17. Expansion card slots supported on the system board

Expansion card riser	PCIe slots on the riser	Processor connection	Height	Length	Slot width
Full height right riser	Slot 2	Processor 1	Full Height	Half Length	x16
Low profile right riser	Slot 2	Processor 1	Low Profile	Half Length	x16
Low profile left riser	Slot 3	Processor 2	Low Profile	Half Length	x16
Butterfly riser	Slot 2	Processor 1	Full Height	Half Length	x16
Butterfly riser	Slot 3	Processor 1	Low Profile	Half Length	x8

NOTE: The expansion-card slots are not hot-swappable.

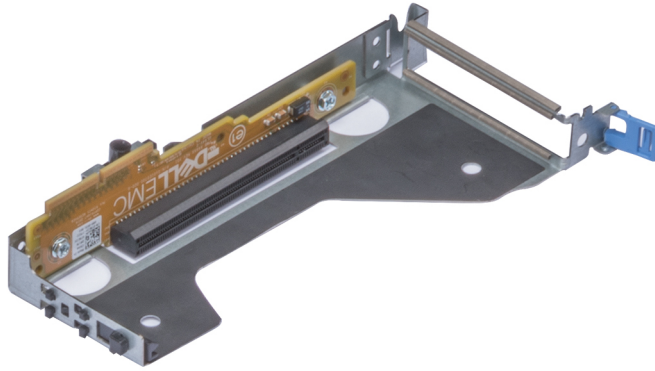

Figure 127. Low-profile (Riser 1)

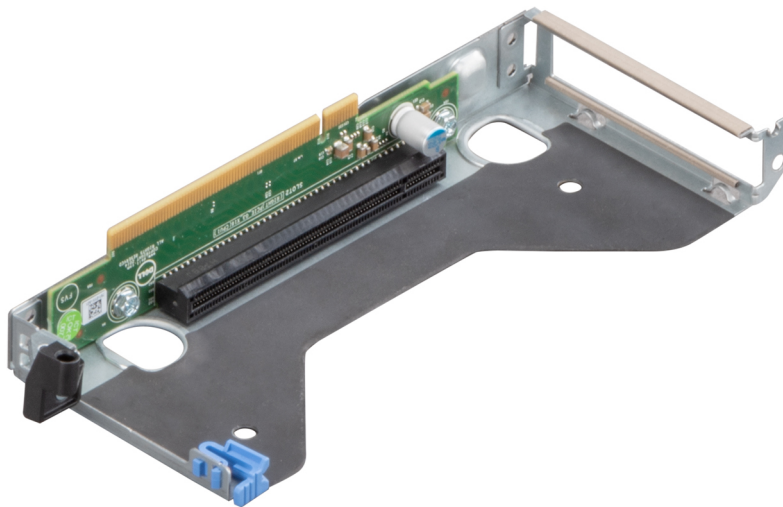

Figure 128. Low-profile (Riser 2)

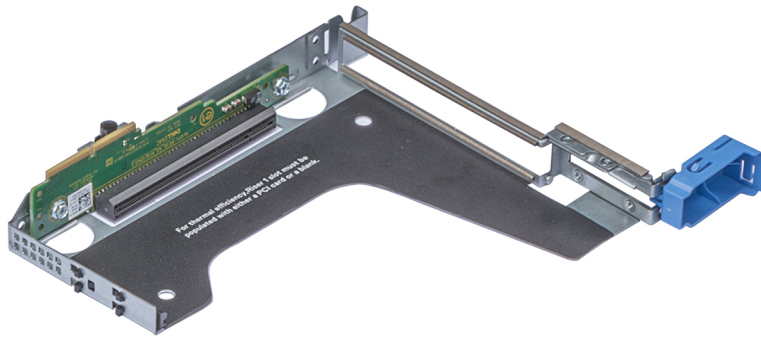

Figure 129. Full-height Riser

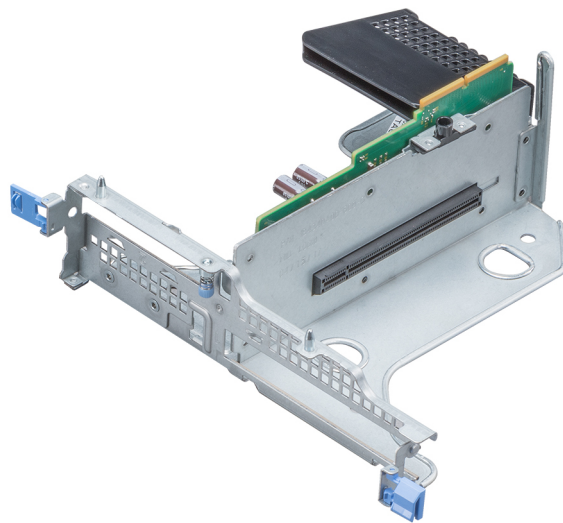

Figure 130. Butterfly Riser

Memory specifications

The Dell EMC XC740xd2 system supports 16 DDR4 registered DIMM (RDIMMs) slots. Supported memory bus frequencies are 1866 MT/s, 2133 MT/s, 2400 MT/s, and 2666 MT/s.

Table 18. Memory specifications

DIMM type	DIMM rank	DIMM capacity	Dual processors	
			Minimum RAM	Maximum RAM
RDIMM	Dual rank	16 GB	64 GB	256 GB
	Dual rank	32 GB	128 GB	512 GB
	Dual rank	64 GB	256 GB	1024 GB

Storage controller specifications

The XC740xd2 system supports the following controller cards.

Table 19. Dell EMC XC740xd2 system controller cards

Internal controllers
HBA330

Drives

The Dell EMC XC740xd2 system supports:

Table 20. Drive specification

Chassis options	Configurations
Twenty-four drive chassis	<p>Up to twenty-four 3.5-inch (SATA or Nearline SAS drives) front accessible drives in slots 0 through 23 and</p> <p>Up to eight 2.5-inch (SAS, SATA SSDs) front accessible drives can be installed from slots 16 through 23.</p>

NOTE: 2.5-inch drives in 3.5-inch carriers are supported for SAS, and SATA SSD drives.

Ports and connectors specifications

USB ports specifications

Table 21. Dell EMC XC740xd2 system USB specifications

Front		Rear		Internal	
USB port type	No. of ports	USB port type	No. of ports	USB port type	No. of ports
USB 2.0-compliant port	One	USB 3.0-compliant ports	Two	Internal USB 3.0-compliant port	One
Micro USB 2.0-compliant port for iDRAC Direct	One				
<p>NOTE: The micro USB 2.0 compliant port can only be used as an iDRAC Direct or a management port.</p>					

NIC ports specifications

The Dell EMC XC740xd2 system supports up to two Network Interface Controller (NIC) ports on the back panel, which have two 1 Gbps configuration.

NOTE: You can install up to four PCIe add-on NIC cards.

Serial connector specifications

The Dell EMC XC740xd2 system supports one serial connector on the back panel, which is a 9-pin connector, Data Terminal Equipment (DTE), 16550-compliant.

VGA ports specifications

The Dell EMC XC740xd2 system supports one 15-pin VGA ports, on the rear of the system.

IDSDM module

The Dell EMC XC740xd2 system supports optional Internal Dual SD module (IDSDM) module.

The module supports three microSD cards; two cards for IDSDM and one card for vFlash. In 14th generation of XC servers, the IDSDM or vFlash module is combined into a single card module, and is available in the following configurations:

- vFlash or
- vFlash and IDSDM

Table 22. Supported microSD card storage capacity

IDSDM card
· 32 GB
· 64 GB

NOTE: There are two dip switches on the IDSDM or vFlash module for write-protection.

NOTE: One IDSDM card slot is dedicated for redundancy.

NOTE: Use Dell EMC branded microSD cards that are associated with the IDSDM or vFlash configured systems.

Video specifications

The Dell EMC system supports integrated Matrox G200eW3 graphics controller with 16 MB of video frame buffer.

Table 23. Supported video resolution options

Resolution	Refresh rate (Hz)	Color depth (bits)
1024 x 768	60	8, 16, 32
1280 x 800	60	8, 16, 32
1280 x 1024	60	8, 16, 32
1360 x 768	60	8, 16, 32
1440 x 900	60	8, 16, 32
1600 x 900	60	8, 16, 32
1600 x 1200	60	8, 16, 32
1680 x 1050	60	8, 16, 32
1920 x 1080	60	8, 16, 32
1920 x 1200	60	8, 16, 32

NOTE: 1920 x 1080 and 1920 x 1200 resolutions are only supported in reduced blanking mode.

Environmental specifications

NOTE: For additional information about environmental certifications, please refer to the Product Environmental Datasheet located with the Manuals & Documents on www.dell.com/xcseriesmanuals

Table 24. Temperature specifications

Temperature	Specifications
Storage	-40–65°C (-40–149°F)
Continuous operation (for altitude less than 950 m or 3117 ft)	10–30°C (50–86°F) with no direct sunlight on the equipment
Fresh air	For information about fresh air, see the Standard operating temperature section.
Maximum temperature gradient (operating and storage)	20°C/h (36°F/h)

Table 25. Relative humidity specifications

Relative humidity	Specifications
Storage	5% to 95% RH with 33°C (91°F) maximum dew point. Atmosphere must be noncondensing at all times.
Operating	10% to 80% RH with 29°C (84.2°F) maximum dew point.

Table 26. Maximum vibration specifications

Maximum vibration	Specifications
Operating	0.26 G _{rms} at 5 Hz to 350 Hz (all operation orientations)
Storage	1.88 G _{rms} at 10 Hz to 500 Hz for 15 minutes (all six sides tested)

Table 27. Maximum shock pulse specifications

Maximum shock pulse	Specifications
Operating	Six consecutively executed shock pulses in the positive and negative x, y, and z axis of 6 G for up to 11 ms.
Storage	Six consecutively executed shock pulses in the positive and negative x, y, and z axis (one pulse on each side of the system) of 71 G for up to 2 ms.

Table 28. Maximum altitude specifications

Maximum altitude	Specifications
Operating	3048 m (10,000 ft)
Storage	12,000 m (39,370 ft)

Table 29. Operating temperature derating specifications

Operating temperature derating	Specifications
Up to 30°C (86°F)	Maximum temperature is reduced by 1°C/300 m (1°F/547 ft), above 950 m (3,117 ft).
30–40°C (86–104°F)	Maximum temperature is reduced by 1°C/175 m (1°F/319 ft), above 950 m (3,117 ft).
40–45°C (104–113°F)	Maximum temperature is reduced by 1°C/125 m (1°F/228 ft), above 950 m (3,117 ft).

Standard operating temperature

Table 30. Standard operating temperature specifications

Standard operating temperature	Specifications
Continuous operation (for altitude less than 950 m or 3117 ft)	10°C to 30°C (50°F to 86°F) with no direct sunlight on the equipment.

Thermal restrictions

- System must operate at temperature below 30°C.
- All fans installed in the system must be from the same manufacturer.
- Fresh air condition is not supported.
- Non Dell qualified or certified processors are not supported.
- LRDIMM is not supported.
- 10 GbE / 25 GbE OCPs require PCIe shroud with rear drive configuration if there is no PCIe card installed.
- Butterfly without riser configuration cannot support 10GbE / 25GbE OCP because PCIe shroud cannot be installed.
- Drive bays should not be in service position for more than 5 minutes because of thermal concerns. When the drive bay is open for more than five minutes, the cooling fans spin at a higher speed to provide extra cooling to the system. Thus system health status changes from the normal to critical state, and system event `The BP1 drive bay is kept open for an extended period of time` is logged.
- GPGPU card is not supported.
- Non Dell certified peripheral cards are not supported.
- Expansion card and riser installation must follow specific Expansion card installation guidelines.
- Mellanox CX-5 dual port 100G - QSPF PCIe adapter cable is restricted to Dell NW QSPF28 Direct attach cables and Finisar 100G 85C optic cables. Non Dell certified cables are not supported.

Table 31. Thermal limitation standard

Configuration		Maximum no.of processors supported		DIMM blanks	Heat Sink	Type of Air shroud	Fan
		Quantity	Model				
Butterfly Configuration	No riser	1 or 2 processors	<=140 W	Required	Processor 1 : Standard heat sink Processor 2: 1.5 U HPR heatsink	2U Air shroud	6 x High Performance fans
	With Butterfly Riser						

Particulate and gaseous contamination specifications

The following table defines the limitations that help avoid any equipment damage or failure from particulates and gaseous contamination. If the levels of particulates or gaseous pollution exceed the specified limitations and result in equipment damage or failure, you may need to rectify the environmental conditions. Re-mediation of environmental conditions is the responsibility of the customer.

Table 32. Particulate contamination specifications

Particulate contamination	Specifications
Air filtration	<p>Data center air filtration as defined by ISO Class 8 per ISO 14644-1 with a 95% upper confidence limit.</p> <p>i NOTE: This condition applies to data center environments only. Air filtration requirements do not apply to IT equipment designed to be used outside a data center, in environments such as an office or factory floor.</p> <p>i NOTE: Air entering the data center must have MERV11 or MERV13 filtration.</p>

Particulate contamination	Specifications
Conductive dust	Air must be free of conductive dust, zinc whiskers, or other conductive particles. NOTE: This condition applies to data center and non-data center environments.
Corrosive dust	<ul style="list-style-type: none"> Air must be free of corrosive dust. Residual dust present in the air must have a deliquescent point less than 60% relative humidity. NOTE: This condition applies to data center and non-data center environments.

Table 33. Gaseous contamination specifications

Gaseous contamination	Specifications
Copper coupon corrosion rate	<300 Å/month per Class G1 as defined by ANSI/ISA71.04-1985.
Silver coupon corrosion rate	<200 Å/month as defined by AHSRAE TC9.9.

NOTE: Maximum corrosive contaminant levels measured at ≤50% relative humidity.

Enhanced Preboot System Assessment

If you experience a problem with your system, run the system diagnostics before contacting Dell for technical assistance. The purpose of running system diagnostics is to test your system hardware without requiring more equipment or risking data loss. If you are unable to fix the problem yourself, service and support personnel can use the diagnostics results to help you solve the problem.

Dell Embedded system diagnostics

NOTE: The Dell Embedded System Diagnostics is also known as Enhanced Preboot System Assessment (ePSA) diagnostics.

The embedded system diagnostics provides a set of options for particular device groups or devices allowing you to:

- Run tests automatically or in an interactive mode.
- Repeat tests
- Display or save test results.
- Introduce more test options for extra information about the failed devices, run a thorough test.
- View status messages that inform you if tests are completed successfully.
- View error messages that inform you of problems encountered during testing.

Running the Embedded system diagnostics from Boot Manager

To run the embedded system diagnostics from Boot Manager:

1. As the system boots, press <F11>.



2. Using the arrow keys select **System Utilities** → **Launch Diagnostics**.

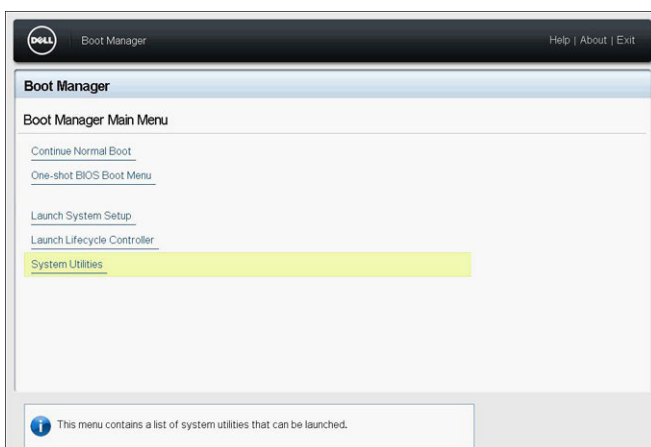

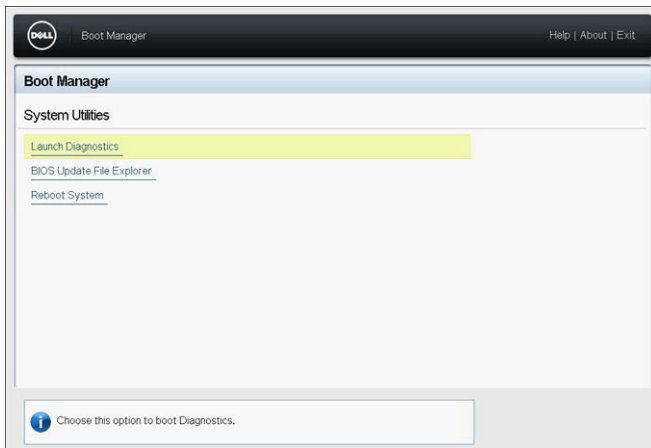

3. Wait while the Quick Tests automatically run.

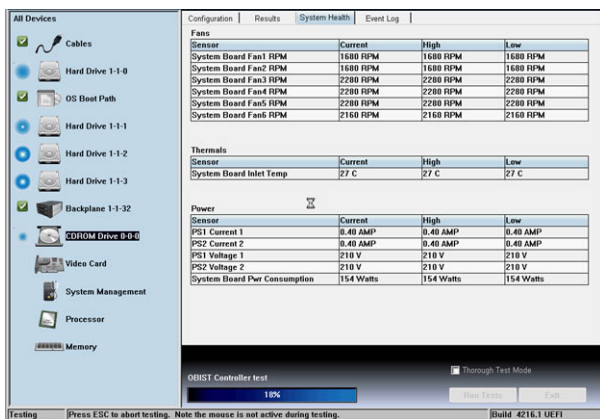

- Once the tests have been completed, you can view the results and additional information on the **Results** tab, the **System Health** tab, the **Configuration** tab, and the **Event Log** tab.
- Close the **Embedded System Diagnostics** utility.
- To leave the diagnostics, click **Exit**.
- Click **OK** when prompted, and the system reboots.

Running the Embedded System Diagnostics from the Dell Lifecycle Controller

To run the embedded system diagnostics from the Dell Lifecycle Controller:

- As the system boots, press **F10**.

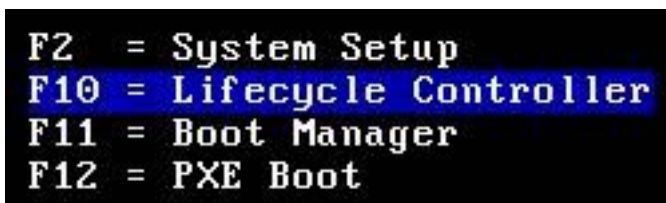

- Select **Hardware Diagnostics** → **Run Hardware Diagnostics**.

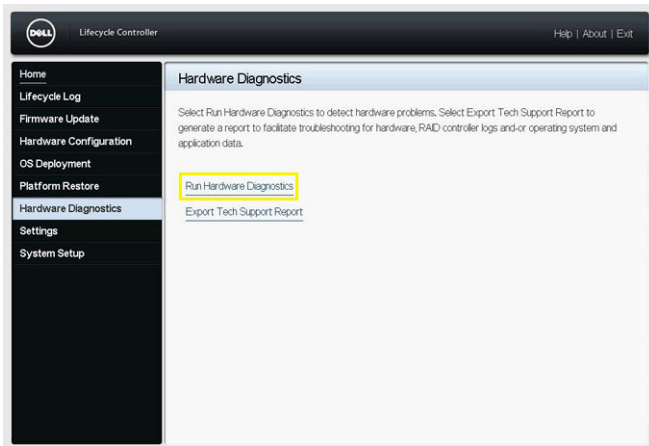

Getting help

Topics:

- [Recycling or End-of-Life service information](#)
- [Contacting Dell](#)
- [Accessing system information by using QRL](#)
- [Receiving automated support with SupportAssist](#)

Recycling or End-of-Life service information

Take back and recycling services are offered for this product in certain countries. If you want to dispose of system components, visit www.dell.com/recyclingworldwide and select the relevant country.

Contacting Dell

Dell provides several online and telephone based support and service options. If you do not have an active internet connection, you can find contact information about your purchase invoice, packing slip, bill, or Dell product catalog. Availability varies by country and product, and some services may not be available in your area. To contact Dell for sales, technical assistance, or customer service issues:

Steps

1. Go to www.dell.com/support/home
2. Select your country from the drop-down menu on the lower right corner of the page.
3. For customized support:
 - a) Enter your system Service Tag in the **Enter your Service Tag** field.
 - b) Click **Submit**.
The support page that lists the various support categories is displayed.
4. For general support:
 - a) Select your product category.
 - b) Select your product segment.
 - c) Select your product.
The support page that lists the various support categories is displayed.
5. For contact details of Dell Global Technical Support:
 - a) Click [Global Technical Support](#)
 - b) The **Contact Technical Support** page is displayed with details to call, chat, or e-mail the Dell Global Technical Support team.

Accessing system information by using QRL

You can use the Quick Resource Locator (QRL) located on the information tag in the front of the XC XR2, to access the information about the Dell EMC XC XR2.

Prerequisites

Ensure that your smartphone or tablet has the QR code scanner installed.

The QRL includes the following information about your system:

- How-to videos
- Reference materials, including the Installation and Service Manual, LCD diagnostics, and mechanical overview
- Your system service tag to quickly access your specific hardware configuration and warranty information
- A direct link to Dell to contact technical assistance and sales teams

Steps

1. Go to www.dell.com/qrl and navigate to your specific product or
2. Use your smartphone or tablet to scan the model-specific Quick Resource (QR) code on your system or in the Quick Resource Locator section.

Receiving automated support with SupportAssist

Dell EMC SupportAssist is an optional Dell EMC Services offering that automates technical support for your Dell EMC server, storage, and networking devices. By installing and setting up a SupportAssist application in your IT environment, you can receive the following benefits:

- **Automated issue detection** — SupportAssist monitors your Dell EMC devices and automatically detects hardware issues, both proactively and predictively.
- **Automated case creation** — When an issue is detected, SupportAssist automatically opens a support case with Dell EMC Technical Support.
- **Automated diagnostic collection** — SupportAssist automatically collects system state information from your devices and uploads it securely to Dell EMC. This information is used by Dell EMC Technical Support to troubleshoot the issue.
- **Proactive contact** — A Dell EMC Technical Support agent contacts you about the support case and helps you resolve the issue.

The available benefits vary depending on the Dell EMC Service entitlement purchased for your device. For more information about SupportAssist, go to www.dell.com/supportassist.

Documentation resources

This section provides information about the documentation resources for your system.

To view the document that is listed in the documentation resources table:

- From the Dell EMC support site:
 1. Click the documentation link that is provided in the Location column in the table.
 2. Click the required product or product version.
 3. On the Product Support page, click **Manuals & documents**.
- Using search engines:
 - Type the name and version of the document in the search box.

NOTE: To locate the product name and model, see the front of your system.

Table 34. Additional documentation resources for your system

Task	Document	Location
Setting up your system	For more information about installing and securing the system into a rack, see the Rail Installation Guide included with your rack solution. For information about setting up your system, see the <i>Getting Started Guide</i> document that is shipped with your system.	www.dell.com/xcseriesmanuals
Configuring your system	For information about the iDRAC features, configuring and logging in to iDRAC, and managing your system remotely, see the Integrated Dell Remote Access Controller User's Guide. For information about understanding Remote Access Controller Admin (RACADM) subcommands and supported RACADM interfaces, see the RACADM CLI Guide for iDRAC. For information about Redfish and its protocol, supported schema, and Redfish Eventing implemented in iDRAC, see the Redfish API Guide. For information about iDRAC property database group and object descriptions, see the Attribute Registry Guide.	www.dell.com/xcseriesmanuals
	For information about earlier versions of the iDRAC documents. To identify the version of iDRAC available on your system, on the iDRAC web interface, click ? > About .	www.dell.com/idracmanuals
	For information about installing the operating system, see the operating system documentation.	www.dell.com/operatingsystemmanuals
	For information about updating drivers and firmware, see the Methods to download firmware and drivers section in this document.	www.dell.com/support/drivers
Managing your system	For information about systems management software offered by Dell, see the Dell	www.dell.com/xcseriesmanuals

Task	Document	Location
	OpenManage Systems Management Overview Guide.	
	For information about installing and using Dell SupportAssist, see the Dell EMC SupportAssist Enterprise User's Guide.	www.dell.com/serviceabilitytools
	For information about partner programs enterprise systems management, see the OpenManage Connections Enterprise Systems Management documents.	www.dell.com/openmanagemanuals
Working with the Dell PowerEdge RAID controllers	For information about understanding the features of the BOSS card and deploying the cards, see the Storage controller documentation.	www.dell.com/storagecontrollermanuals
Understanding event and error messages	For information about the event and error messages generated by the system firmware and agents that monitor system components, see the Error Code Lookup.	www.dell.com/qrl
Troubleshooting your system	For information about identifying and troubleshooting the XC systems issues, see the XC systems Troubleshooting Guide.	www.dell.com/xcseriesmanuals