

Dell EMC SmartFabric OS10 Installation, Upgrade, and Downgrade Guide

Document Version 7

Notes, cautions, and warnings

 **NOTE:** A NOTE indicates important information that helps you make better use of your product.

 **CAUTION:** A CAUTION indicates either potential damage to hardware or loss of data and tells you how to avoid the problem.

 **WARNING:** A WARNING indicates a potential for property damage, personal injury, or death.

Chapter 1: About this guide	5
Revision history.....	5
Related Documents.....	6
Documentation Feedback.....	6
Chapter 2: Installing SmartFabric OS10	7
Uninstall existing OS.....	7
Download OS10 image.....	7
Install OS10.....	8
Automatic installation.....	9
Manual installation.....	10
Log in to an OS10 switch.....	11
Install OS10 license.....	12
Chapter 3: Preparing for an upgrade	15
Dell EMC SmartFabric OS10 certificate expiration and recommended action.....	15
Supported upgrade paths—Full Switch mode deployments.....	16
Supported upgrade paths—SFS mode in Dell EMC VxRail deployments.....	17
Supported upgrade paths—Dell EMC PowerEdge MX deployments.....	18
Platform-specific prerequisites.....	18
Prerequisites for solution deployments.....	19
Startup configuration during upgrade or downgrade.....	20
Chapter 4: Upgrading OS10 software	21
Upgrade OS10 automatically using ZTD.....	21
Upgrade OS10 manually from the CLI.....	22
Download OS10 image for upgrade.....	22
Perform an OS10 upgrade.....	22
Upgrade OS10 on VLT nodes with minimal traffic loss.....	25
VLT upgrade with minimal loss for upgrades from 10.5.0.5 or earlier to 10.5.1.9 or later releases.....	28
VLT upgrade with minimal loss in a VLT or VXLAN topology if network statements are used to advertise BGP prefixes.....	29
Upgrade from OS9 to OS10.....	29
Postupgrade certificate configurations.....	30
Chapter 5: Downgrading OS10 software	31
Downgrade to OS10 release 10.5.0.9 or earlier.....	31
Downgrade to OS10 release 10.5.1.x or later.....	33
Rollback from OS10 release 10.5.2.0 or later to 10.5.0.9 or earlier.....	35
Rollback from OS10 release 10.5.2.0 or later to 10.5.1.9 or later.....	35
Appendix A: Update ONIE and ONIE firmware	37
Appendix B: Upgrade PCIe firmware from DIAG OS	40

Appendix C: Upgrade PCIe firmware from OS10 hshell.....	42
Appendix D: Links to ONIE Firmware Updater and DIAG OS Release Notes.....	44
Appendix E: Frequently asked questions.....	45

About this guide

This guide is intended for system administrators who are responsible for installing, upgrading, and maintaining networks. It includes the following chapters:

- [Installing SmartFabric OS10](#)
- [Preparing for upgrade](#)
- [Upgrading OS10 software](#)
- [Downgrading OS10 software](#)
- [Frequently asked questions](#)

This document may contain language that is not consistent with current guidelines of Dell Technologies. There are plans to update this document over subsequent releases to revise the language accordingly.

Revision history

The following table provides an overview of the changes to this guide from a previous version.

Table 1. Revision history

Revision	Date	Revision summary
A06	2021-11-09	Added information about startup configuration information during upgrade and downgrade.
A05	2021-10-12	Updated the following sections: <ul style="list-style-type: none"> • Supported upgrade paths—Full switch mode deployments • Supported upgrade paths—SFS mode in Dell EMC VxRail deployments Added the Update ONIE and ONIE Firmware section.
A04	2021-08-27	Removed the note about upgrading SmartFabric OS10 on the Z9100-ON switch from the Upgrading OS10 software section.
A03	2021-07-29	Updated the Supported upgrade paths-Full switch mode deployments section with the procedure to upgrade from 10.4.2.x or earlier releases.
A02	2021-07-13	<ul style="list-style-type: none"> • Updated the Supported upgrade paths section. • Added PCIe upgrade instructions for S5200-ON platforms. • Added links to the ONIE Firmware Updater and DIAG OS Release Notes.
A01	2021-07-02	Added the following: <ul style="list-style-type: none"> • Information about certificate expiry and prerequisites. • S4100-ON platform-specific prerequisites.

Table 1. Revision history (continued)

Revision	Date	Revision summary
		<ul style="list-style-type: none"> FAQs
A00	2021-03-04	Initial release.

Related Documents

The following table lists the related documentation.

Table 2. Related Documentation

Related Documentation	Description	Link
<i>Dell EMC SmartFabric OS10 Release Notes</i>	This document includes: <ul style="list-style-type: none"> New feature information Known and resolved caveats 	Dell EMC Networking OS10 Info Hub
<i>Dell EMC SmartFabric OS10 User Guide</i>	This document includes: <ul style="list-style-type: none"> Installation and setup of Dell EMC SmartFabric OS10. Description, configuration information, limitations and restrictions, and examples of features that SmartFabric OS10 supports. Reference information and examples on configuring protocols. For complete information about protocols, see the related documentation, including Internet Engineering Task Force (IETF) and Request For Comments (RFC). Command reference information for all the SmartFabric OS10 CLI commands. 	
<i>Dell EMC SmartFabric OS10 Quick Start Guide</i>	This document contains quick start and interoperability information to assist with the installation, upgrade, and set up of in-band and out-of-band management, authentication, and interoperability between Dell-Dell and Dell-OEM devices.	
<i>Dell EMC SmartFabric OS10 Security Guide</i>	This document provides a set of recommendations for securing switches that run Dell EMC SmartFabric OS10.	

Documentation Feedback

Dell Technologies strives to provide accurate and comprehensive documentation and welcomes your suggestions and comments. You can provide feedback in the following ways:

- Online feedback form—Rate the documentation or provide your feedback on any of the documentation pages at www.dell.com/support.
- Email—Send your feedback to networkingpub.feedback@dell.com. Include the document title, release number, chapter title, and section title of the text corresponding to the feedback.

To get answers to your questions related to Dell EMC SmartFabric OS10 through email, chat, or call, go to the [Technical Support](#) page.

Installing SmartFabric OS10

This chapter provides instructions about installing SmartFabric OS10 on a Dell EMC ONIE-enabled switch.

If the switch does not have a default OS installed, download an OS10 software image from the Dell Digital Locker and install it using ONIE. You can also use the following procedure to install OS10 on a Dell EMC ONIE device when:

- You convert a switch from OS9 or any third-party OS.
- You receive a replacement device from Dell EMC return material authorization (RMA)—A replacement switch comes without an OS or license installed. If you receive a replacement switch, you must assign the service tag (STAG) of the replacement switch to the SW entitlement in DDL and install the OS10 software and license.

An OS10 image that you download has a 120-day trial license and requires a perpetual license to run beyond the trial period. For more information about installing the switch, see the Setup Guide that is shipped with your device and the following FAQs:

- [Frequently asked Questions](#)
- [My Account FAQs](#)

To install an OS10 image and extend the OS10 license beyond the trial period on a Dell EMC ONIE switch with no OS installed, perform the following tasks in the specified order:

1. (Optional) If a different OS is installed on the switch, such as OS9, uninstall the existing OS—See [Uninstall existing OS](#).
2. [Download an OS10 image](#).
3. [Install OS10 using ONIE](#).
4. [Log in to an OS10 switch](#).
5. [Install an OS10 license](#).

Uninstall existing OS

CAUTION: To install OS10 on a switch running OS9 or another third-party OS, you must first uninstall the existing OS. The Uninstall option deletes the switch configuration and all disk partitions.

To uninstall OS9 or a third-party OS on a Dell EMC ONIE switch, boot up the switch and watch for the ONIE boot menu to display. Immediately use the Arrow keys to scroll the asterisk and select the ONIE: `Uninstall OS` option to avoid the switch booting to ONIE: `Install OS` by default.

```
+-----+
| ONIE: Install OS          |
| ONIE: Rescue             |
|*ONIE: Uninstall OS      |
| ONIE: Update ONIE       |
| ONIE: Embed ONIE        |
| ONIE: Diag ONIE         |
+-----+
```

After the ONIE uninstall process completes, the switch boots to ONIE: `Install OS` mode.

Download OS10 image

If you purchase the OS10 Enterprise Edition image with an after point-of-sale order, your OS10 purchase allows you to download software images posted within the first 90 days of ownership. After the order is complete, you receive an email notification with a software entitlement ID, order number, and link to the DDL.

To extend the software-entitled download period, you must have a Dell EMC ProSupport or ProSupport Plus contract on your hardware. Bind the software entitlement to the switch service tag to be the same time as the support contract:

NOTE: MX-Series Ethernet I/O modules support OS10 in the 10.5.0.1 and later releases. The OS10 image is packaged as a Dell Upgrade Package (DUP) and is downloaded from www.dell.com/support/. For information about how to upgrade the IOMs, see the Dell EMC MX Networking Deployment Guide.

1. Sign into [DDL](#) using your account credentials.
2. Locate your entitlement ID and order number that is sent by email, and then select the product name.
3. On the **Product** page, the `Assigned To` field on the Product tab is blank. Click **Key Available for Download**.
4. Enter the device service tag you purchased the OS10 Enterprise Edition for in the `Bind to` and `Re-enter ID` fields. This step binds the software entitlement to the service tag of the switch.
5. Select how to receive the license key: by email or downloaded to your local device.
6. Click **Submit** to download the License.zip file.
7. Select the **Available Downloads** tab.
8. Select the OS10 Enterprise Edition release to download, and then click **Download**.
9. Read the Dell End User License Agreement. Scroll to the end of the agreement, and then click **Yes, I agree**.
10. Select how to download the software files, and then click **Download Now**.
11. After you download the OS10 Enterprise Edition image, unpack the .tar file and store the OS10 binary image on a local server. To unpack the .tar file, follow these guidelines:
 - Extract the OS10 binary file from the .tar file. For example, to unpack a .tar file on a Linux server or from the ONIE prompt, enter:

```
tar -xf tar_filename
```

- Generate a checksum for the downloaded OS10 binary image by running the `sha256sum` command on the image file. Ensure that the generated checksum matches the checksum in the image SHA-256 file that is extracted from the .tar file.

```
sha256sum image_filename
```

12. Follow the procedures in [Install OS10](#) and [Install OS10 license](#) to install an OS10 Enterprise Edition image and license.

Install OS10

CAUTION: Installing OS10 using ONIE erases all software configurations on the switch. The configuration settings are not recoverable. Back up all software configurations and installed licenses on the switch before performing OS updates or changes. Store a regular backup of the switch configuration off the switch.

If you want to replace an existing OS, download an OS10 image as described in [Download OS10 image](#). Then install an OS10 software image using ONIE-based auto-discovery or a manual installation:

- **Automatic installation**—ONIE discovers network information including the Dynamic Host Configuration Protocol (DHCP) server, connects to an image server, and downloads and installs an image automatically.
- **Manual installation**—Manually configure your network information if a DHCP server is not available or if you install the OS10 software image using USB media.

System setup

Before installation, verify that the system is connected correctly:

- Connect a serial cable and terminal emulator to the console serial port — serial port settings are 115200 baud rate, 8 data bits, and no parity.
- Connect the Management port to the network to download an image over a network. To locate the Console port and the Management port, see the platform-specific *Installation Guide* at www.dell.com/support.

Install OS10

Go to the ONIE boot menu. An ONIE-enabled switch boots up with pre-loaded diagnostics (DIAGs) and ONIE software.

```
+-----+
|*ONIE: Install OS          |
| ONIE: Rescue             |
| ONIE: Uninstall OS      |
| ONIE: Update ONIE       |
| ONIE: Embed ONIE        |
```

```
| ONIE: Diag ONIE |
+-----+
|
```

- Install OS—Boots to the ONIE prompt and installs an OS10 image using the Automatic Discovery process. When ONIE installs a new OS image, the previously installed image and OS10 configuration are deleted.
- Rescue—Boots to the ONIE prompt and enables manual installation of an OS10 image or ONIE update.
- Uninstall OS—Deletes the contents of all disk partitions, including the OS10 configuration, except ONIE and diagnostics.
- Update ONIE—Installs a new ONIE version.
- Embed ONIE—Formats the disk and installs ONIE.
- EDA DIAG—Runs the system diagnostics.

After the ONIE process installs an OS10 image and you later reboot the switch in `ONIE: Install OS` mode (default), ONIE takes ownership of the system and remains in Install mode (ONIE Install mode is sticky) until an OS10 image successfully installs again. To boot the switch from ONIE for any reason other than installation, select the `ONIE: Rescue` or `ONIE: Update ONIE` option from the ONIE boot menu.

CAUTION: During an automatic or manual OS10 installation, if an error condition occurs that results in an unsuccessful installation and if there is an existing OS on the device, select `Uninstall OS` to clear the partitions. If the problem persists, contact Dell EMC Technical Support.

Automatic installation

You can automatically install an OS10 image on a Dell EMC ONIE-enabled device. This process is known as zero-touch install. After the device boots to `ONIE: Install OS`, ONIE auto-discovery follows these steps to locate the installer file and uses the first successful method:

1. Use a statically configured path that is passed from the boot loader.
2. Search file systems on locally attached devices, such as USB.
3. Search the exact URLs from a DHCPv4 server.
4. Search the inexact URLs based on the DHCP responses.
5. Search IPv6 neighbors.
6. Start a TFTP waterfall.

The ONIE automatic discovery process locates the stored software image, downloads and installs it, and reboots the device with the new image. Auto-discovery repeats until a successful software image installation occurs and reboots the switch.

ONIE discovery — Usage information

- All ONIE auto-discovery methods download and run only supported default file names, such as `onie-installer`. The required file names and search order are described on the Open Network Install Environment website at [Image Discovery and Execution](#). For more information, see the *Open Networking Hardware Diagnostic Guide* on the [Dell EMC Support site](#).
- If you use a DHCPv4 server, ONIE auto-discovery obtains the hostname, domain name, Management interface IP address, and the IP address of the domain name server (DNS) from the DHCP server and DHCP options. It also searches SCP, FTP, or TFTP servers with the default DNS of the ONIE server. DHCP options are not used to provide the server IP.
- If you use a USB storage device, ONIE searches only FAT32 or EXT2 file systems for an OS10 image.

Example: OS10 automatic installation

1. On the TFTP server, rename the OS10 image to a supported installer file name, such as `onie-installer`, using the `mv image-name default-filename` command.

```
mv PKGS_OS10-Base-10.3.1B.144-installer-x86_64.bin onie-installer
```

2. Boot up the switch in `ONIE: Install` mode to install an OS10 image.

```
Starting: discover... done.
ONIE:/ # Info: eth0: Checking link... up.
Info: Trying DHCPv4 on interface: eth0
ONIE: Using DHCPv4 addr: eth0: 10.10.10.17 / 255.0.0.0
Info: eth1: Checking link... down.
ONIE: eth1: link down. Skipping configuration.
ONIE: Failed to configure eth1 interface
ONIE: Starting ONIE Service Discovery
Info: Fetching tftp://10.10.10.2/onie-installer-x86_64-dellemc_s4148fe_c2338 ...
Info: Fetching tftp://10.10.10.2/onie-installer-dellemc_s4148fe_c2338 ...
```

```

Info: Fetching tftp://10.10.10.2/onie-installer-x86_64-bcm ...
Info: Fetching tftp://10.10.10.2/onie-installer-x86_64 ...
Info: Fetching tftp://10.10.10.2/onie-installer ...
ONIE: Executing installer: tftp://10.10.10.2/onie-installer
...
...
...
Press <DEL> or <F2> to enter setup.
Welcome to GRUB!

GNU GRUB version 2.02~beta2+e4a1fe391
OS10-B
EDA-DIAG
ONIE Booting `OS10-A'
Loading OS10 ...

[ 3.883826] kvm: already loaded the other module
[ 3.967628] dummy-irq: no IRQ given. Use irq=N
[ 3.973212] mic_init not running on X100 ret -19
[ 3.980168] esas2r: driver will not be loaded because no ATTO esas2r devices were
found
[ 4.021676] mtdoops: mtd device (mtddev=name/number) must be supplied
[ 5.092316] i8042: No controller found
[ 5.108356] fmc_write_eeprom fake-design-for-testing-f001: fmc_write_eeprom: no
busid passed, refusing all cards
[ 5.120111] intel_rapl: driver does not support CPU family 6 model 77
[ 4.226593] systemd-fsck[493]: OS10-SYSROOT1: clean, 23571/426544 files,
312838/1704960 blocks
Debian GNU/Linux 8 OS10 ttyS0
Dell EMC Networking Operating System (OS10)
OS10 login:

```

Manual installation

If you do not use the ONIE-based automatic installation of an OS10 image and if a DHCP server is not available, you can manually install the image. Configure the Management port and provide the software image file to start the installation.

1. Save the OS10 software image on an SCP/TFTP/FTP server.
2. Power up the switch and select ONIE Rescue for manual installation.
3. Stop DHCP discovery.

```
$ onie-discovery-stop
```

4. Configure the IP addresses on the Management port, where *x.x.x.x* represents your internal IP address. After you configure the Management port, the response is up.

```
$ ifconfig eth0 x.x.x.x netmask 255.255.0.0 up
```

5. Install the software on the device. The installation command accesses the OS10 software from the specified SCP, TFTP, or FTP URL, creates partitions, verifies installation, and reboots itself.

```
$ onie-nos-install image_url
```

For example, enter

```
ONIE:/ # onie-nos-install ftp://a.b.c.d/PKGS_OS10-Enterprise-x.x.xx.bin
```

6. Where *a.b.c.d* represents the location to download the image file from, and *x.x.xx* represents the version number of the software to install.

The OS10 installer image creates partitions and installs the OS10 software. After installation completes, the switch automatically reboots and loads OS10 active image. The other image becomes the standby image.

intellectual property laws. Dell EMC and the Dell EMC logo are trademarks of Dell Inc. in the United States and/or other jurisdictions. All other marks and names mentioned herein may be trademarks of their respective companies.

```
OS10# configure terminal

OS10# configure terminal
OS10(config)# username admin password alpha404! role sysadmin
OS10(config)# exit
OS10# write memory
```

When logging into a switch, it may take 6 to 10 seconds for the CLI prompt to display. Change the `linuxadmin` user password from the OS10 CLI after the first OS10 login. For more information, see the User Management section in the Dell EMC SmartFabric OS10 User Guide.

Install OS10 license

If OS10 is factory-loaded on your switch, you do not need to install an OS10 license as it is pre-loaded with a perpetual license. If you download OS10 on a trial basis, OS10 comes with a 120-day trial license. ONIE installation on a factory-loaded Dell EMC switch wipes out the license partition. Hence, the switch on reload comes up with a default 120 day trial license. Purchase and install a perpetual license after the trial period expires. To continue with uninterrupted use, purchase and install a perpetual license to avoid the OS10 device rebooting every 72 hours after 120 days.

After you install OS10 and log in, install the perpetual license to run OS10 Enterprise Edition beyond the trial period. The OS10 license is installed in the `/mnt/license` directory.

1. Download the `License.zip` file from DDL as described in [Download OS10 image](#).
2. Open the zip file and locate the license file in the Dell folder. Copy the license file to a local or remote workstation.
3. Install the license file from the workstation in EXEC mode.

```
license install {ftp: | http: | localfs: | scp: | sftp: | tftp: | usb:} filepath/
filename
```

- `ftp://userid:passwd@hostip/filepath`—Copy from a remote FTP server.
- `http://hostip/filepath`—Copy from a remote HTTP server.
- `http://hostip`—Send a request to a remote HTTP server.
- `localfs://filepath`—Install from a local file directory.
- `scp://userid:passwd@hostip/filepath` —Copy from a remote SCP server.
- `sftp://userid:passwd@hostip/filepath`—Copy from a remote SFTP server.
- `tftp://hostip/filepath` —Copy from a remote TFTP server.
- `usb://filepath`—Install from a file directory on a storage device connected to the USB storage port on the switch.
- `filepath/filename`—Enter the directory path where the license file is stored.

NOTE: When installing a license through a VRF instance, OS10 supports only some file transfer methods. The following table details the file transfer methods supported in default, management, and non-default VRF instances.

Table 3. Install license using VRF

File transfer method	Default VRF	Management VRF ¹	Non-default VRF
FTP	Yes	Yes	No
HTTP	Yes	Yes	No
localfs	Yes	Yes	Yes
SCP	Yes	Yes	No
SFTP	Yes	Yes	No
TFTP	Yes	Yes	No
USB	Yes	Yes	Yes

Table 3. Install license using VRF (continued)

File transfer method	Default VRF	Management VRF ¹	Non-default VRF
¹ Before you configure the management VRF for use in an OS10 license installation, remove all IP and IPv6 addresses on the management interface.			

Install license — SCP

```
OS10# license install scp://user:userpwd@10.1.1.10/0A900Q2-NOSEEnterprise-License.xml  
License installation success.
```

Install license — localfs

Follow these steps to install a license from a local file directory:

1. Copy the license file from the SCP server location to the home directory on the system.

```
OS10# copy scp://admin:admin@10.11.95.101//home/admin/LADF/0A900Q2-NOSEEnterprise-  
License.XML home://7B900Q2-NOSEEnterprise-License.XML
```

2. (optional) Check the status of the file copy using the `show copy-file status` command.

```
OS10# show copy-file status  
File Transfer State: idle  
-----  
State Detail: idle  
Task Start: 2019-02-15T00:46:35Z  
Task End: 2019-02-15T00:46:36Z  
Transfer Progress: 100 %  
Transfer Bytes: 3795 bytes  
File Size: 3795 bytes  
Transfer Rate: 8 kbps
```

3. Verify that the license is present in the home directory of your system.

```
OS10# dir home  
  
Directory contents for folder: home  
Date (modified) Size (bytes) Name  
-----  
2019-02-15T00:47:25Z 3795 0A900Q2-NOSEEnterprise-License.XML
```

4. Enter the `license install` command with the path to the home directory location where the license was downloaded in step 1.

```
OS10# license install localfs://home/admin/0A900Q2-NOSEEnterprise-License.XML  
License installation success.
```

Install license using management VRF

```
OS10(config)# ip vrf management  
OS10(conf-vrf)# interface management  
OS10(conf-vrf)# exit  
OS10(config)# ip sftp vrf management  
OS10(config)# exit  
OS10# license install sftp://user:userpwd@10.1.1.10/0ANNX42-NOSEEnterprise-License.xml  
  
License installation success.
```

Verify license installation

```
OS10# show license status  
  
System Information  
-----  
Vendor Name : DELL EMC  
Product Name : S4148F-ON  
Hardware Version : X01  
Platform Name : x86_64-dell_s4100_c2338-r0
```

```
PPID : TW09H9MN282987130026
Service Tag : 9531XC2
Product Base :
Product Serial Number:
Product Part Number :
License Details
-----
Software : OS10-Enterprise
Version : 10.5.1.0
License Type : PERPETUAL
License Duration: Unlimited
License Status : Active
License location: /mnt/license/9531XC2.lic
-----
```

Troubleshoot license installation failure

An error message displays if the installation fails.

```
License installation failed
```

1. Verify the installation path to the local or remote license location.
2. Check the log of the remote server to find out why the FTP or TFTP file transfer failed.
3. Ping the remote server from the switch—use the `ping` and `tracert` commands to test network connectivity. Check the following if the ping fails:
 - If the remote server is reachable through the management route, check if the management route is configured correctly.
 - If the remote server is reachable through a front-panel port, check if the static or dynamic route is present.
 - If the ping is successful and the FTP or TFTP log on to a remote server does not register a response, check if there is a firewall in the transfer path that is blocking the transfer protocol.
4. Install the server with the license file on the same subnet as the switch.
5. Check if the server is up and running.

Preparing for an upgrade

This chapter provides you a list of prerequisites that you must ensure are met before you upgrade the SmartFabric OS10 nodes in your network. Review the information in this chapter carefully and plan for your upgrade.

Dell EMC SmartFabric OS10 certificate expiration and recommended action

Specific versions of OS10 (see [Affected versions](#)) use X.509v3 certificates for VLT peer establishment and SFS cluster formation. This default certificate expires on July 27, 2021. [LKB 184027](#) provides steps for addressing this issue, including either executing the script to update the default certificate or upgrading to a version that does not use the certificate.

For systems that do not have the default certificate updated or are running a version that uses the X.509v3 certificates for VLT peer or SFS cluster convergence ([Affected versions](#)), see the [Supported Upgrade Paths](#) section for details:

- [Supported upgrade paths—Full Switch mode deployments](#)
- [Supported upgrade paths—SFS mode in Dell EMC VxRail deployments](#)
- [Supported upgrade paths—Dell EMC PowerEdge MX deployments](#)

NOTE: Before you update the certificate, ensure that the clock on the switch shows the correct time.

- **For SmartFabric OS10 Deployments:**

Affected versions: Include the following:

- 10.3.2E(R3P1)
- 10.4.0E(R3SP2) through 10.4.0E(R4SP2)
- 10.4.1.4 through 10.4.3.6P5
- 10.5.0.0 through 10.5.0.7P3

Fixed versions: The following OS10 release versions come with new default certificates that address the certificate expiry issue:

- 10.4.3.7
- 10.5.0.9
- 10.5.1.9
- 10.5.2.6 and later releases

See [Supported upgrade paths—Full Switch mode deployments](#) for more information.

- **For SFS VxRail Deployments:**

SFS cluster members use X.509 certificates to establish communication. See [Supported upgrade paths—SFS mode in Dell EMC VxRail deployments](#).

- **For PowerEdge MX Deployments**

For PowerEdge MX7000 Ethernet switches that run any of the following versions with new certificates installed, see the latest [Dell EMC OpenManage Enterprise-Modular Edition for PowerEdge MX7000 Chassis User's Guide](#) for upgrade instructions:

- 10.4.0E(R3SP2)
- 10.4.0E(R4S)
- 10.4.0E(R4SP1)
- 10.4.0E(R4SP2)

Supported upgrade paths—Full Switch mode deployments

The following table lists the supported upgrade paths for SmartFabric OS10 in Full Switch mode deployments.

- NOTE:** Follow the validated upgrade paths listed in this table before you upgrade to the latest release. Ensure that you back up the configuration data and license files in an external storage. The notation *A* » *B* indicates that OS10 supports direct upgrade from Release *A* to Release *B*.
- NOTE:** For instructions about upgrading OS10 on a pair of VLT nodes, see [Upgrade OS10 on VLT nodes with minimal traffic loss](#).
- NOTE:** If you are deploying an OS10 switch that has a factory-loaded older version of the OS10 software, Dell Technologies recommends that you download the latest version of the software and perform a fresh installation. See [Installing SmartFabric OS10](#) section for details.
- NOTE:** The default X.509v3 certificates used for VLT and SFS cluster convergence expire on July 27, 2021. See [Dell EMC SmartFabric OS10 certificate expiration and recommended action](#) for additional information before you start the VLT upgrade procedure.

Table 4. Full Switch mode deployments

Release	Supported upgrade paths for non-VLT deployments	Supported upgrade paths for VLT deployments
10.5.2.x	You can directly upgrade to 10.5.3.0	You can directly upgrade to 10.5.3.0
10.5.1.x	You can directly upgrade to 10.5.2.x or later	You can directly upgrade to 10.5.2.x or later
10.5.0.x	You can directly upgrade to 10.5.2.x or later	When you are upgrading from 10.5.0.x: <ol style="list-style-type: none"> 1. Install the new default certificate using the certificate update script available in DDL. See LKB 184027 for instructions on how to run the certificate update script. 2. The upgrade path is 10.5.0.x » 10.5.0.9 » 10.5.2.6 or later.
10.4.3.x	You can directly upgrade to: <ul style="list-style-type: none"> • 10.5.0.x • 10.5.1.x To upgrade to the latest release: 10.4.3.x » 10.5.1.x » 10.5.2.x or later	When you are upgrading from 10.4.3.x: <ol style="list-style-type: none"> 1. Install the new default certificate using the certificate update script available in DDL. See LKB 184027 for instructions on how to run the certificate update script. 2. <ul style="list-style-type: none"> • For S5100-ON platform, upgrade to 10.4.3.7. • For all other platforms, the upgrade path is 10.4.3.x » 10.5.0.9 » 10.5.2.6 or later.
10.4.2.x and earlier	To move from 10.4.2.x or earlier release to a later release, follow the steps outlined in this procedure: <ul style="list-style-type: none"> NOTE: The following procedure requires a maintenance window. You can expect traffic disruption during this time. This procedure takes about 45 minutes to complete on a single switch. If required, move the VMs and network traffic to another part of the network during this time. 1. Back up the configuration data and license files in an external storage. 2. Reload the device. 3. Boot the system in ONIE: <code>Uninstall</code> mode and uninstall the existing OS10 software. 4. Download the latest ONIE software from the platform-specific Drivers & Downloads page at https://www.dell.com/support. Enter the platform name in the Search box. For example, to view the S4048-ON platform-related information, enter <code>PowerSwitch S4048-ON</code> in the Search box. 5. Boot the system in ONIE: <code>Update</code> mode and install the latest ONIE software (<code>onie-updater</code>). 6. Boot the system in ONIE: <code>Install</code> mode and install the desired OS10 version. 7. Reapply the configuration data and license files after you install OS10. 	

Table 4. Full Switch mode deployments (continued)

Release	Supported upgrade paths for non-VLT deployments	Supported upgrade paths for VLT deployments
	<p>NOTE: PowerEdge MX switches running OS10 10.4.0E releases must upgrade to 10.5.x.x releases. See the latest Dell EMC OpenManage Enterprise-Modular Edition for PowerEdge MX7000 Chassis User's Guide for instructions on the upgrade path to the desired OS10 version.</p>	

Supported upgrade paths—SFS mode in Dell EMC VxRail deployments

The following table lists the supported upgrade paths for SmartFabric OS10 in SFS mode (VxRail) deployments.

NOTE: Follow the validated upgrade paths listed in this table before you upgrade to the latest release. The notation *A » B* indicates that OS10 supports direct upgrade from Release A to Release B.

NOTE: The default X.509v3 certificates used for VLT and SFS cluster convergence expire on July 27, 2021. See [LKB 184027](#) for more information.

Table 5. SmartFabric Services mode in VxRail deployments

Release	Supported upgrade paths
<ul style="list-style-type: none"> 10.5.2.3 10.5.2.6 10.5.2.7 	You can directly upgrade to 10.5.3.0.
10.5.0.9	You can directly upgrade to 10.5.2.6 or later.
<ul style="list-style-type: none"> 10.5.0.0P5 10.5.0.2 10.5.0.5 10.5.0.5P2 10.5.0.7P3 	<ol style="list-style-type: none"> 1. Install the new default certificate using the certificate update script available in DDL. See LKB 184027 for instructions on how to run the certificate update script. 2. The upgrade paths are: <ul style="list-style-type: none"> 10.5.0.0P5 » 10.5.0.9 » 10.5.2.6 or later 10.5.0.2 » 10.5.0.9 » 10.5.2.6 or later 10.5.0.5 » 10.5.0.9 » 10.5.2.6 or later 10.5.0.5P2 » 10.5.0.9 » 10.5.2.6 or later 10.5.0.7P3 » 10.5.2.6 or later
10.4.3.x	<ol style="list-style-type: none"> 1. Install the new default certificate using the certificate update script available in DDL. See LKB 184027 for instructions on how to run the certificate update script. 2. The upgrade paths are: <ul style="list-style-type: none"> 10.4.3.4 » 10.4.3.7 » 10.5.0.9 » 10.5.2.6 or later 10.4.3.6P3 » 10.5.0.9 » 10.5.2.6 or later
10.4.1.x	<ul style="list-style-type: none"> You can directly upgrade to 10.4.3.7. To upgrade to the latest release: 10.4.1.4 » 10.4.3.7 » 10.5.0.9 » 10.5.2.6 or later <p>NOTE: A maintenance window is required for this upgrade.</p>

Important notes

- Single rack SFS upgrade from Release 10.5.0.7P3 to 10.5.2.6 or later with breakout configuration on uplink connections**

For VxRail single rack deployment with two leaf switches, if there is breakout configuration on the uplink connections, do not use the OMNI user interface for upgrade. Use the OS10 CLI to and follow the steps listed below to upgrade the switches:

1. Upgrade the SFS standby node from the CLI. After the SFS standby node is upgraded and joins the cluster, perform a switchover through the Linux shell to make this node the SFS primary node (Master). To do this, you must enter the following commands:

```
system sudo -i
python /opt/dell/os10/bin/rest-service/tool/dnv_cli.py
dnv$ switchover
dnv$ exit
```

2. Upgrade the second node after the switchover.

- **Single rack SFS upgrade from Release 10.5.0.7P3 to 10.5.2.6 or later without breakout configuration on uplink connections**

For VxRail single rack deployment with two leaf switches, if there is no breakout configuration on the uplink connections, follow the normal upgrade procedure using the OMNI user interface.

- **Dell EMC Networking SFS deployment with VxRail four-node cluster**

In a VxRail four-node cluster deployment, if you have deployed S4100-ON switches, see the [Dell EMC PowerSwitch S4100-ON Series ONIE Firmware Updater Release Notes](#) for the latest recommended ONIE and ONIE firmware versions. We recommend that you upgrade ONIE and ONIE firmware to the latest recommended versions before you upgrade OS10.

- See the [Networking Solutions Support Matrix](#) for more information.

Supported upgrade paths—Dell EMC PowerEdge MX deployments

For a list of supported upgrade paths for OS10 in PowerEdge MX Deployments, see the latest [Dell EMC OpenManage Enterprise-Modular Edition for PowerEdge MX7000 Chassis User's Guide](#).

Platform-specific prerequisites

Before you upgrade, ensure that the following prerequisites are met:

All platforms

- Ensure that you back up the configuration data and license files in an external storage.
- If you have VLT enabled, ensure that you make note of the X.509v3 security profile name to reinstall the X.509v3 certificate after upgrade. Use the `show crypto cert` command to view the security profile name.

S4100-ON platform

If you are upgrading OS10 from Release 10.5.0.x or earlier to Release 10.5.1.9 or later on an S4100-ON series platform, you must ensure that the `realpath` variable in OS10-Boot is set to `/dev/sda4`. To check the `realpath` variable, enter the `system "realpath /dev/disk/by-label/OS10-BOOT"` command from the OS10 CLI:

```
OS10# system "realpath /dev/disk/by-label/OS10-BOOT"
```

If the `realpath` variable is:

- Set to `/dev/sda4`, proceed with OS10 upgrade.
- Not set to `/dev/sda4`, you must uninstall the existing OS10 version and reinstall the new version of OS10. To do this:
 1. Back up the current running configuration (Release 10.5.0.x or earlier) to an external storage.

```
OS10# copy running-configuration scp://userid:passwd@hostip/filepath/
runningconfiguration.txt
```

2. Reload the switch and watch for the ONIE boot menu.
3. Use the arrow keys to scroll and select ONIE: Uninstall OS option.

- After you reload the switch again, from the ONIE boot menu, select the ONIE: `Install OS` option and install Release 10.5.1.9 or later release. See [Installing SmartFabric OS10](#) section for more information.

S5200-ON platform

This section provides information about PCIe requirements and prerequisite checks that you must do before you upgrade OS10.

PCIe Requirements

The following table lists the OS10 releases and the recommended PCIe firmware version for that release.

Table 6. OS10 releases and supported PCIe versions

OS10 Release	PCIe firmware version	SDK version
10.4.3.x	Less than or equal to 2.5	SDK-6.5.14
10.5.0.x and later	2.6	SDK-6.5.16

If you are upgrading OS10 from 10.4.3.x to 10.5.1.9 or later, perform the following steps in the specified order:

- Upgrade OS10 from Release 10.4.3.x to 10.5.0.9.
- Check the version of the PCIe firmware. To check the PCIe firmware version, enter the `system "sudo os10-switch-shell 'pciephy fw version'"` command from the OS10 CLI:

```
OS10# system "sudo os10-switch-shell 'pciephy fw version'"
[sudo] password for admin:
0:soc_flash_init: Flash supported ID = 0x20
PCIe FW loader version: 2.5
PCIe FW version: D102_08
SAI.0>
```

- If the `PCIe FW loader version` is 2.5—Upgrade the PCIe firmware before you upgrade OS10 to Release 10.5.1.9 or later. You can update the PCIe firmware using one of the following options:
 - From Diag OS—Dell Technologies strongly recommends that you update the PCIe firmware from the DIAG OS. To use this option, you need console access to the switch. See [Upgrade PCIe firmware from DIAG OS](#) for more information.
 - From OS10 hshell—If you do not have console access to the switch, you can upgrade PCIe from the OS10 hshell. See [Upgrade PCIe firmware from OS10 hshell](#) for more information. If you choose this option, you must shut down all the ports on the switch before you upgrade the PCIe firmware.

After you upgrade the PCIe firmware, upgrade OS10 to Release 10.5.1.9 or later.

- If the `PCIe FW loader version` is 2.6—Upgrade OS10 to Release 10.5.1.9 or later.

For a list of latest recommended firmware versions for the different platforms, see the Platform-specific ONIE Firmware Updater Release Notes on the [Dell EMC Support Site](#).

Prerequisites for solution deployments

Before you upgrade, ensure that the following prerequisites are met:

For a list of supported versions, see the [Networking Solutions Support Matrix](#).

- For SFS deployments on S and Z Series switches, upgrade to Release 10.5.0.9 before you upgrade to Release 10.5.1.9 or later.
- If you have SFS enabled and you have custom certificates (self-signed or CA certificates) installed, ensure that you make note of the X.509v3 security profile name to reinstall the X.509v3 certificate after upgrade. Use the `show crypto cert` command to view the security profile name.
- For MX deployments, use the OME-M console to upgrade the IOMs in the fabric. For instructions on upgrading the IOMs, see the *Dell EMC MX Networking Deployment Guide*.
- For VxRail solution, before upgrading OS10 nodes, perform the following:
 - Disable failback on all configured port-groups.
 - On vCenter, go to the **Networking** tab and make the following settings on each port group:
 - Click **Action** -> **Edit Settings** -> **Teaming and Failover** and set **Failback** to **No**.

2. Move OMNI to Maintenance mode. For instructions on how to enable maintenance mode in OMNI, see the respective version of the [OpenManage Network Integration for SmartFabric Services User Guide](#).
3. (Applicable only for the S4112-ON switches) Upgrade all the switches from 10.4.3.x to 10.4.3.7 through CLI starting with the backup switch.
4. Upgrade all the switches to 10.5.0.9 through OMNI.
5. Disable OMNI maintenance mode. For instructions on how to disable maintenance mode in OMNI, see the respective version of the [OpenManage Network Integration for SmartFabric Services User Guide](#).
6. Enable failback on all configured port-groups.
 - a. On vCenter, go to the **Networking** tab and make the following settings on each port group:
 - i. Click **Action** -> **Edit Settings** -> **Teaming and Failover** and set **Failback** to **Yes**.

Startup configuration during upgrade or downgrade

This section is only applicable for Release 10.5.1.0 or later.

Each version of OS10 has a copy of startup configuration, which acts as a backup while falling back to that version.

- During upgrade, the startup configuration is copied from a lower version to a higher version whether or not a configuration file is available in the image corresponding to the higher version.
- During downgrade, the backed-up startup configuration of the target version is used, provided it is not erased with the `image install` command. Configuration changes done while in the higher version are lost.
- When a lower version is installed using the `image install` command, the startup configuration is not backed up for that version and therefore the switch starts with the default configuration.
 - Maintenance releases based on the same main release (for example, 10.5.1.0 and 10.5.1.1) are considered as different versions. Therefore, downgrade to a lower version follows the above behavior of starting with the default configuration.
 - Patch releases based on the same base release (for example, 10.5.1.1P1 and 10.5.1.1P2) are considered as same version and configuration is carried forward even when upgrading or downgrading using the `image install` command.
- Even if the startup configuration is deleted in the newer version, the older version still uses its own saved configuration.

Upgrading OS10 software

This chapter explains how to upgrade SmartFabric OS10 software (OS10) on Dell EMC PowerSwitches. You can upgrade OS10 software on standalone OS10 nodes or OS10 nodes in a VLT setup. You can also upgrade a switch from OS9 to OS10. OS10 upgrades are available for download from the Dell Digital Locker (DDL). A factory-loaded OS10 image includes a perpetual license.

Requirements

SmartFabric OS10 software image on a server (HTTP, FTP, SCP, SFTP, TFTP) or universal serial bus (USB) media.

Table 7. Upgrade procedures

Task	Section
To upgrade OS10 on a switch	You can use any one of the following methods: <ul style="list-style-type: none"> Upgrade OS10 automatically using ZTD Upgrade OS10 manually from the CLI
To upgrade OS10 on a pair of VLT nodes	Upgrade OS10 on VLT nodes with minimal traffic loss
To upgrade from OS9 to OS10	Upgrade from OS9 to OS10

NOTE: Do not upgrade the ONIE firmware and OS10 image simultaneously. Perform the ONIE firmware upgrade first before you upgrade the OS10 image.

Upgrade OS10 automatically using ZTD

The zero touch deployment (ZTD) process is enabled by default and starts an automatic discovery process, similar to the ONIE discovery process.

ZTD starts the Dynamic Host Configuration Protocol (DHCP) client on all the interfaces, including management and front-panel ports. ZTD sends DHCP discovery packets with DHCP option 60 (vendor-class specifier) on all the interfaces and listens for the DHCP offer. The DHCP server responds with Option 240 in its response (the DHCP offer). Option 240 includes the valid OS10 image and configuration files. The system proceeds with ZTD, installs OS10 image, and executes the configuration files.

NOTE: The DHCP server response with Option 240 is received through the management port or a front-panel port.

The ZTD auto discovery runs continuously until any of the discovery methods complete or you cancel the ZTD process manually using the `ztd cancel` command or you enter into CONFIGURATION mode.

Example: OS10 automatic installation

```
<165>1 2021-11-07T09:20:04.313553+00:00 OS10 dn-app-ztd 835
- - Node.1-Unit.1:PRI [event], Dell EMC (OS10) %ZTD-START: DHCP callback
received, starting Zero Touch Deployment
```

After ZTD completes, use the `show ztd-status` command to view the ZTD status. A message similar to the following appears:

```
OS10# show ztd-status

-----
ZTD Status      : disabled
ZTD State       : completed
Protocol State  : idle
Reason          : ZTD process completed successfully at Sun Nov 7 09:42:52 2021
-----
```

For more information about how to automate switch deployment, see the *Dell EMC SmartFabric OS10 User Guide*.

Upgrade OS10 manually from the CLI

To upgrade an OS10 image, first download and unpack the new OS10 binary image as described in [Download OS10 image for upgrade](#). Then copy the binary image file to a local server and follow the steps in [Perform OS10 upgrade](#).

NOTE: To upgrade a Dell EMC ONIE switch to OS10 from OS9 or another network operating system (NOS), follow the procedure in [Upgrade from OS9 to OS10 using the ONIE-Install OS](#).

Download OS10 image for upgrade

NOTE: For MX-Series Ethernet I/O modules, OS10 updates are packaged as Dell Upgrade Packages (DUPs) and are downloaded from www.dell.com/support/. For information about how to download the DUP files to upgrade OS10 on an MX9116n and MX5108n switch, see the *Dell EMC PowerEdge MX Networking Deployment Guide*.

To upgrade an existing OS10 image, first download a new OS10 Enterprise Edition image from DDL.

1. Sign into [DDL](#) using your account credentials.
2. Locate the entry for your entitlement ID and order number, and then select the product name.
3. Select the **Available Downloads** tab on the Product page.
4. Select the OS10 Enterprise Edition image to download, and then click **Download**.
5. Read the Dell End User License Agreement, and then scroll to the end of the agreement and click **Yes, I agree**.
6. Select how to download the software files, then click **Download Now**.
7. After you download the OS10 Enterprise Edition image, unpack the .tar file and store the OS10 binary image on a local server. To unpack the .tar file, follow these guidelines:
 - Extract the OS10 binary file from the .tar file. For example, to unpack a .tar file on a Linux server or from the ONIE prompt, enter:

```
tar -xf tar_filename
```

NOTE: Some Windows unzip applications insert extra carriage returns (CR) or line feeds (LF) when they extract the contents of a .tar file. The extra CRs and LFs may corrupt the downloaded OS10 binary image. Turn OFF this option if you use a Windows-based tool to untar an OS10 binary file. For example, in WinRAR under the **Advanced Options** tab, de-select the .tar file smart CR/LF conversion feature.

- Generate a checksum for the downloaded OS10 binary image by using the `sha256sum` command on the image file. Ensure that the generated checksum matches the checksum in the image SHA-256 file that is extracted from the .tar file.

```
sha256sum image_filename
```

8. Follow the procedure in [Perform OS10 upgrade](#).

Perform an OS10 upgrade

After you download and unpack a new OS10 binary image as described in [Download OS10 image for upgrade](#), follow these steps:

NOTE:

- Use the `image download` command to download the software image to the system—it does not install the software on your device. The `image install` command installs the downloaded image, which becomes the standby image.
- If the active image includes any modified text files or custom packages that were installed earlier, they are not available with the standby image. Back up the modified files and custom packages and reinstall them after downloading the image.

CAUTION: Do not use copy commands to download the image to the switch, as this action may result in loss of disk space for critical system applications and functions, and it may be difficult to locate the image.

1. Back up the current running configuration to the startup configuration in EXEC mode. Alternatively, use the `write memory` command to copy the current running configuration to the startup configuration.

```
OS10# copy running-configuration startup-configuration
```

2. Back up the startup configuration in EXEC mode.

```
OS10# copy config://startup.xml config://<backup file name>
```

3. Enter the system `"file /mnt/onie-boot/onie/vmlinuz*"` command from the OS10 CLI to check the version of the ONIE Linux kernel.

```
OS10# system "file /mnt/onie-boot/onie/vmlinuz*"
/mnt/onie-boot/onie/vmlinuz-3.14.27-onie: Linux kernel x86 boot executable bzImage,
version 3.14.27-onie+
(root@arlogin-sjc-01.force10networks.com) #1 SMP Thu Feb 19 17:09:11 PST 2015, RO-
rootFS, swap_dev 0x3, Normal VGA
```

If the ONIE Linux kernel version is:

- 3.x.x—See the ONIE Firmware Updater Release Notes for the latest recommended ONIE and ONIE firmware versions and update them. See [Appendix A](#) for a list of links to the ONIE Firmware Updater Release Notes for the different platforms.
 - 4.x.x—Proceed with OS10 upgrade.
4. Download the new software image from the [Dell Support Site](#), extract the `bin` files from the `tar` file, and save the file in EXEC mode.

```
OS10# image download file-url
```

For example:

```
OS10# image download scp://userid:passwd@hostip:/filepath
```

i **NOTE:** Some Windows extraction applications insert extra carriage returns (CR) or line feeds (LF) when they extract the contents of a `.tar` file, which may corrupt the downloaded OS10 binary image. Turn off this option if you use a Windows-based tool to untar an OS10 binary file.

5. (Optional) View the current software download status in EXEC mode.

```
OS10# show image status
```

6. (Applicable only if you are presently running OS10 release 10.5.0.x or earlier and installing 10.5.2.0 or later now.) Cancel any staged firmware update using the `image cancel` command.

```
OS10# image cancel
```

7. Install the 10.5.2.6 or later software image in EXEC mode.

```
OS10# image install image-url
```

For example:

```
OS10# image install image://filename.bin
```

i **NOTE:** OS10 has two images: A and B. One image is active, which is the present running version and used as the running software at the next system reload. The other image remains standby, used for software upgrades.

The `image install` command installs the downloaded image to the system. If you had modified text files or installed custom packages, they are not available with the standby image. Back up the modified files and custom packages, and reinstall them after downloading the standby image.

8. (Optional) View the status of the current software install in EXEC mode.

```
OS10# show image status
```

9. (Optional) Verify the standby image version.

```
OS10# show boot detail
Current system image information detail:
=====
Type: Node-id 1
Boot Type: Flash Boot
Active Partition: B
Active SW Version: 10.5.0.9
Active SW Build Version: 10.5.0.270
Active Kernel Version: Linux 4.9.168
Active Build Date/Time: 2021-03-07T23:35:01Z
Standby Partition: A
Standby SW Version: 10.5.2.6
Standby SW Build Version: 10.5.2.6
Standby Build Date/Time: 2021-03-07T11:43:33+0000
Next-Boot: standby[A]
NOTE: Use the show boot detail command to check
```

10. Depending on the release that is presently running on your system:

- **System is presently running an OS10 release earlier than 10.5.1.0 and you are installing 10.5.1.9 or later**

Reload the new software image in EXEC mode.

```
OS10# reload
```

- **System is presently running OS10 release 10.5.1.0 or later and you are installing 10.5.2.6 or later now**

a. Change the next boot image to the standby image in EXEC mode.

```
OS10# boot system standby
```

Check whether the next boot has changed to the standby image in EXEC mode.

```
OS10# show boot detail
```

b. Reload the new software image in EXEC mode.

```
OS10# reload
```

i **NOTE:** The OS10 switch boots with the image that you chose.

11. After the installation is complete, use the `show version` command to check if the latest version of the software is running in the system.

The following example shows the 10.5.2.0 software installed and running:

```
OS10# show version
Dell EMC Networking OS10 Enterprise
Copyright (c) 1999-2020 by Dell Inc. All Rights Reserved.
OS Version: 10.5.2.6
Build Version: 10.5.2.6.228
Build Time: 2021-03-07T11:43:33+0000
System Type: S5232F-ON
Architecture: x86_64
Up Time: 01:28:47
OS10#
```

i **NOTE:** Starting from Release 10.5.1.0, SmartFabric OS10 comes with a unified partition. If you have upgraded from an earlier release to 10.5.1.9 or later, the `show boot detail` command output appears as follows:

```
OS10# show boot detail
Image A: 10.5.2.6
Image B: N/A
```

Image B is listed as N/A. However, Image B (older version) resides in the system and is used when you roll back to the previous release.

If you want to update the standby partition with the current OS10 image, use the `copy active-to-standby` command:

```
OS10# image copy active-to-standby
```

This action removes the older version from the standby partition of the system. You can no longer roll back to the previous release. If you want to downgrade, you must follow the instructions provided in the [Downgrade to OS10 release 10.5.0.9 or earlier](#) section.

Upgrade OS10 on VLT nodes with minimal traffic loss

This section describes the steps to upgrade OS10 on VLT peer nodes with minimal traffic loss.

NOTE: The default X.509v3 certificates used for VLT convergence expire on July 27, 2021. See [Dell EMC SmartFabric OS10 certificate expiration and recommended action](#) for additional information before you start the VLT upgrade procedure.

Summary of Upgrade Steps

1. Download the new OS10 image.
2. Install the image on VLT-Peer1 and VLT-Peer2 nodes.
3. Upgrade the secondary VLT node. The production traffic is not affected during this process because the primary VLT node continues to forward traffic.
4. After the secondary VLT node upgrade is complete, upgrade the primary VLT node. During the primary VLT node upgrade, the system reloads. During this reload, the secondary VLT node becomes the primary and continues to forward traffic.

The following describes the VLT upgrade process:

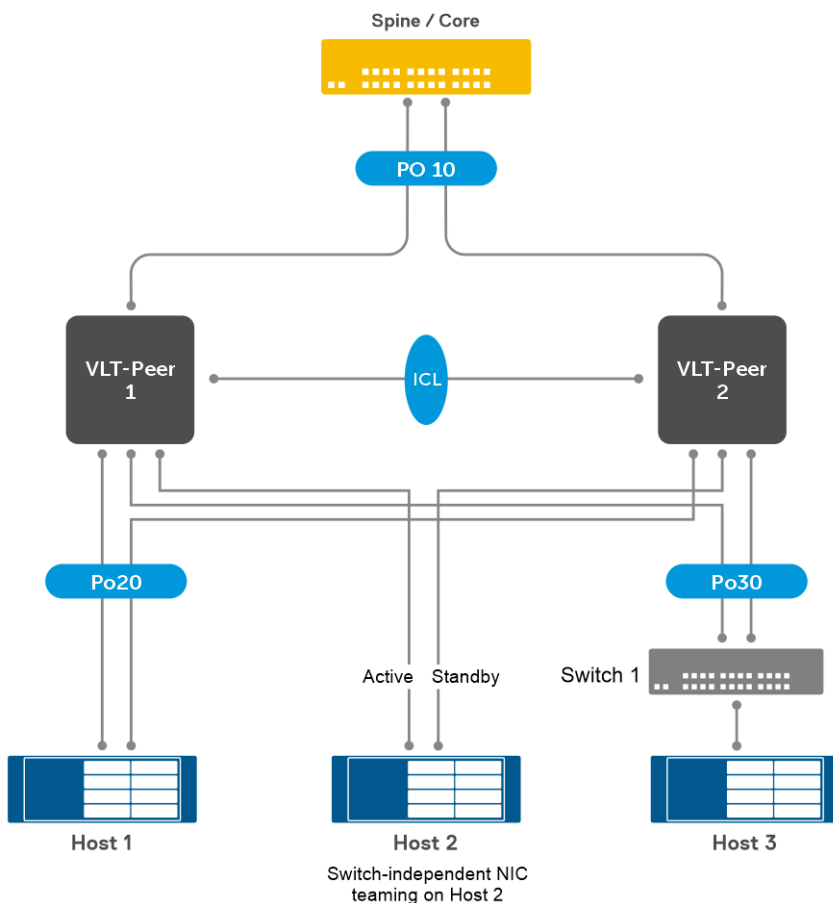

In this example topology:

- VLT-Peer1 and VLT-Peer2 are leaf nodes that are connected to the spine switch through port channel 10.
- Host1 is connected to both the VLT peer nodes through port channel 20.

- Host2 uses switch-independent NIC teaming.
- Switch1 is connected to the VLT peer nodes through port channel 30.

Important notes

- The ports that are connected to Host2 are not part of a VLT port channel. If you have this type of deployment, configure the delay-restore for orphan ports feature on the VLT nodes to reduce traffic loss during upgrade or reload.
 - When you upgrade one of the VLT peer nodes (for example, VLT-Peer1), the forwarding plane continues to forward the traffic to the other node (VLT-Peer2).
 - If you are upgrading VLT nodes from 10.5.0.5 or previous release to 10.5.1.9 or later release, see:
 - [VLT upgrade with minimal loss for upgrades from 10.5.0.5 or earlier to 10.5.1.9 or later releases.](#)
 - [VLT upgrade with minimal loss in a VLT or VXLAN topology if network statements are used to advertise BGP prefixes.](#)
 - You must not make any configuration changes when the VLT peer nodes are running different versions of the software.
1. Download the new software image on both the VLT peer nodes (VLT-Peer 1 and VLT-Peer 2) from the [Dell Support Site](#). Extract the *bin* files from the *tar* file, and save the file in EXEC mode. Download the extracted bin file to the OS10 switch using the `image download` command.

```
image download file-url
```

For example:

```
VLT-Peer1# image download scp://userid:passwd@hostip://filepath
```

```
VLT-Peer2# image download scp://userid:passwd@hostip://filepath
```

NOTE: Some Windows unzip applications insert extra carriage returns (CR) or line feeds (LF) when they extract the contents of a .tar file, which may corrupt the downloaded OS10 binary image. Turn off this option if you use a Windows-based tool to untar an OS10 binary file.

2. (Optional) View the current software download status in EXEC mode.

```
VLT-Peer1# show image status
Image Upgrade State:      idle
=====
File Transfer State:      idle
-----
State Detail:             Completed: No error
Task Start:               2018-08-16T19:38:37Z
Task End:                 2018-08-16T19:38:44Z
Transfer Progress:        100 %
Transfer Bytes:           417828173 bytes
File Size:                417828173 bytes
Transfer Rate:            58152 kbps

Installation State:       idle
-----
State Detail:             No install information available
Task Start:               0000-00-00T00:00:00Z
Task End:                 0000-00-00T00:00:00Z
```

```
VLT-Peer2# show image status
Image Upgrade State:      idle
=====
File Transfer State:      idle
-----
State Detail:             Completed: No error
Task Start:               2018-08-16T19:41:49Z
Task End:                 2018-08-16T19:42:09Z
Transfer Progress:        100 %
Transfer Bytes:           417828173 bytes
File Size:                417828173 bytes
Transfer Rate:            21092 kbps

Installation State:       idle
-----
State Detail:             No install information available
```

```
Task Start:      0000-00-00T00:00:00Z
Task End:        0000-00-00T00:00:00Z
```

3. Install the image using the `image install` command on both the VLT peer nodes.

```
VLT-Peer1# image install image://PKGS_OS10-Enterprise10.5.1.9.483stretch-installer-
x86_64.bin

Install started.
```

```
VLT-Peer2# image install image://PKGS_OS10-Enterprise10.5.1.9.483stretch-installer-
x86_64.bin

Install started.
```

4. Use the `show image status` command to view the installation status.

```
VLT-Peer1# show image status
Image Upgrade State:      idle
=====
File Transfer State:     idle
-----
State Detail:             Completed: No error
Task Start:               2018-08-16T19:38:37Z
Task End:                 2018-08-16T19:38:44Z
Transfer Progress:       100 %
Transfer Bytes:           417828173 bytes
File Size:                417828173 bytes
Transfer Rate:            58152 kbps

Installation State:      idle
-----
State Detail:             Completed: Success
Task Start:               2018-08-16T19:40:57Z
Task End:                 2018-08-16T19:45:16Z
```

```
VLT-Peer2# show image status
Image Upgrade State:      idle
=====
File Transfer State:     idle
-----
State Detail:             Completed: No error
Task Start:               2018-08-16T19:41:49Z
Task End:                 2018-08-16T19:42:09Z
Transfer Progress:       100 %
Transfer Bytes:           417828173 bytes
File Size:                417828173 bytes
Transfer Rate:            21092 kbps

Installation State:      idle
-----
State Detail:             Completed: Success
Task Start:               2018-08-16T19:42:59Z
Task End:                 2018-08-16T19:47:19Z
```

5. Change the boot partition to standby on VLT-Peer1.

```
VLT-Peer1# boot system standby
```

6. Save the configuration to startup-configuration. Optionally obtain a backup of the startup configuration in EXEC mode on VLT-Peer1.

```
VLT-Peer1# write memory
VLT-Peer1# copy config://startup.xml config://<backup file name>
```

7. Reload VLT-Peer1.

```
VLT-Peer1# reload
```

- Wait for VLT-Peer1 to come up. VLT adjacency is established. VLT-Peer1 becomes the secondary node. Wait until VLT-Peer1 starts to forward traffic after the delay-restore timer expires.

```
VLT-Peer1# show vlt 100
Domain ID           : 100
Unit ID            : 2
Role               : secondary
Version           : 2.3
Local System MAC address : 0c:33:d1:73:cd:00
Role priority      : 32768
VLT MAC address    : 0c:33:d1:e7:5e:00
IP address         : fda5:74c8:b79e:1::2
Delay-Restore timer : 90 seconds
Remaining Restore time : 80 seconds
Peer-Routing       : Disabled
```

- Change the boot partition to standby on VLT-Peer2.

```
VLT-Peer2# boot system standby
```

- Save the configuration to startup-configuration. Optionally obtain a backup of the startup configuration in EXEC mode on VLT-Peer2.

```
VLT-Peer2# write memory
VLT-Peer2# copy config://startup.xml config://<backup file name>
```

- Reload VLT-Peer2.

```
VLT-Peer2# reload
```

- Wait for VLT-Peer2 to come up. VLT adjacency is established. VLT-Peer2 becomes the secondary node. Wait until VLT-Peer2 starts to forward traffic after the delay-restore timer expires. To check the delay-restore timer value, enter the `show vlt domain-id` command.

```
VLT-Peer2# show vlt 100
Domain ID           : 100
Unit ID            : 2
Role               : secondary
Version           : 2.3
Local System MAC address : 0c:33:d1:73:ee:00
Role priority      : 32768
VLT MAC address    : 0c:33:d1:e7:5e:00
IP address         : fda5:74c8:b79e:1::2
Delay-Restore timer : 90 seconds
Remaining Restore time : 80 seconds
Peer-Routing       : Disabled
```

When the delay-restore timer expires, the system generates a syslog message similar to the following one:

```
<165>1 2021-02-24T02:29:29.296791+00:00 host1 dn_alm 881 - - Node.1-Unit.1:PRI
[event], Dell EMC (OS10) %VLT_DELAY_RESTORE_COMPLETE: VLT delay restore timer stop
```

Upgrade on VLT peer nodes is now complete. Both the nodes actively forward traffic. After upgrade, VLT-Peer1 is the primary node and VLT-Peer2 is the secondary node.

VLT upgrade with minimal loss for upgrades from 10.5.0.5 or earlier to 10.5.1.9 or later releases

- NOTE:** The default X.509v3 certificates used for VLT convergence expire on July 27, 2021. See [Dell EMC SmartFabric OS10 certificate expiration and recommended action](#) for additional information before you start the VLT upgrade procedure.
- NOTE:** This procedure is applicable only when upgrading to 10.5.1.9 or future releases from 10.5.0.5 or earlier OS10 releases. This VLT upgrade procedure is not applicable when upgrading to 10.5.2.6 or future releases from 10.5.0.6 or later releases. You can directly upgrade VLT nodes from 10.5.0.6 or later release to 10.5.2.6 or future release using the regular VLT upgrade procedure.

1. Upgrade one VLT peer (VLT-Peer1) running a 10.5.0.x or 10.4.3.x release image to 10.5.0.9 or later, using the standard image upgrade procedure. Reboot the switch with the newly installed image. Wait for VLT-Peer1 to forward traffic after the delay restore timer stops.
2. Upgrade the other VLT peer (VLT-Peer2), running a 10.5.0.x or 10.4.3.x release image to 10.5.0.9 or later, using the standard image upgrade procedure. Reboot the switch with the newly installed image. Wait for VLT-Peer2 to forward traffic after the delay restore timer stops.
3. Upgrade one VLT peer (VLT-Peer1) to 10.5.1.9 or later/10.5.2.6 or later using the standard image upgrade procedure. Reboot the switch with the newly installed image. Wait for VLT-Peer1 to forward traffic after the delay restore timer stops.
4. Upgrade the other VLT peer (VLT-Peer2) to 10.5.1.9 or later/10.5.2.6 or later using the standard image upgrade procedure. Reboot the switch with the newly installed image.

VLT upgrade with minimal loss in a VLT or VXLAN topology if network statements are used to advertise BGP prefixes

NOTE: The following procedure is not applicable when upgrading to 10.5.2.6 or future releases from 10.5.1.x releases. You can directly upgrade VLT nodes from 10.5.1.x to 10.5.2.6 or future release.

NOTE:

- This section is applicable only if `network` statements are used under `address-family {ipv4|ipv6} unicast` to advertise prefixes that are present in both VLT peers.
- If you have not used `network` statements and instead used `redistribute connected` to advertise prefixes, you avoid this additional step.
- If the prefix advertised using a `network` statement is present only on one of the VLT peers, you avoid this additional step for those prefixes alone.

This section covers the additional steps needed to achieve a VLT upgrade to 10.5.2.6 or later from a 10.5.0.x or 10.4.3.x release with minimal traffic loss in a VLT or VXLAN topology.

NOTE: The steps in the following example are for IPv4. Follow the same steps for IPv6 where applicable.

1. Apply a route map to set the `origin` as `IGP` for the prefixes on both VLT peers in a VLT domain one after the other.

```
OS10# configure terminal
OS10(config)# route-map set_origin
OS10(config-route-map)# set origin igp
OS10(config-route-map)# exit
OS10(config)# router bgp <AS-Number>
OS10(config-router-bgp-<AS-Number>)# address-family ipv4 unicast
OS10(configure-router-bgpv4-af)# network <prefix> route-map set_origin
OS10(configure-router-bgpv4-af)# end
OS10#
```

2. Follow the VLT min-loss upgrade procedure outlined above.
3. Remove the route-map on both VLT peers one after the other.

```
OS10(config)# router bgp <AS-Number>
OS10(config-router-bgp-<AS-Number>)# address-family ipv4 unicast
OS10(configure-router-bgpv4-af)# no network <prefix> route-map set_origin
OS10(configure-router-bgpv4-af)# network <prefix>
OS10(configure-router-bgpv4-af)#
```

For more information on the `network` command, see the **BGP commands** section in the *Dell EMC SmartFabric OS10 User Guide*.

Upgrade from OS9 to OS10

When you upgrade an OS9 switch to OS10, the first step is to uninstall OS9 using the ONIE: Uninstall OS option on the ONIE boot menu. The Uninstall option deletes the OS9 configuration and all disk partitions. After you uninstall OS9, follow the steps to install OS10 on a Dell EMC ONIE device:

1. [Uninstall existing OS.](#)
2. [Download an OS10 image.](#)
3. [Install OS10 using ONIE.](#)
4. [Log in to an OS10 switch.](#)
5. [Download and install an OS10 license.](#)

Postupgrade certificate configurations

Switches running OS10 Release 10.5.0.7P3 and previous supported releases, that have VLT or SmartFabric Services enabled, use secure channels to communicate with each other. To establish secure channels, OS10 uses X.509v3 certificates. If you have installed custom certificates (self-signed or CA certificates), you must reinstall the custom certificates after upgrade.

NOTE: This procedure is applicable only if you have installed custom certificates, and are running OS10 release 10.4.3.0 or later. If you are running OS10 releases between 10.4.1.4 and 10.4.2.x, upgrade to a later release. This procedure is not applicable if you are upgrading to one of the following releases:

- 10.4.3.7
- 10.5.0.9
- 10.5.1.9
- 10.5.2.6 and later releases

Configuration notes

- From 10.5.1.0 release onwards, there is no need for X.509v3 certificate in a VLT domain if both the VLT peers are running OS10 software version 10.5.1.0 or later. However, you still need the certificates during VLT upgrade from 10.4.3.x releases to 10.5.1.0 or later. The upgraded VLT device has to communicate with the other VLT peer in a domain until the other device is also upgraded to 10.5.1.0 or later.
- If untrusted devices access management or data ports on an OS10 switch in your deployment, Dell Technologies recommends that you replace the default X.509v3 certificate-key pair used for cluster applications. See the *Dell EMC SmartFabric OS10 Security Best Practices Guide* for information about generating and installing certificates on OS10 switches.

After you upgrade OS10 to a new release, the certificate is present in the system. To reinstall the certificate, remove and readd the cluster security profile using the following commands:

1. Remove the cluster security profile.

```
OS10(config)# no cluster security-profile
```

2. Add the cluster security profile again for the certificates to be reinstalled.

```
OS10(config)# cluster security-profile profile-name
```

Downgrading OS10 software

This chapter explains how to downgrade OS10 on Dell EMC PowerSwitches.

OS10 supports downgrading to an earlier release using the `image install` command. The following table lists the sections in this chapter.

- NOTE:** Instead of a downgrade, you can rollback to an earlier release when the previous image is available in the system as the standby image.
- NOTE:** (Applicable only for VLT and SFS deployments) Before you downgrade, review the information in the [Dell EMC SmartFabric OS10 certificate expiration and recommended action](#) section.
 - If you have installed the new X.509v3 certificates or are currently on a release that includes the fix, downgrading to one of the affected versions will result in traffic loss. If you are downgrading to an affected release, after downgrade, you must update the certificates on all the nodes using the script (for VLT and SFS cluster convergence). You will need a maintenance window to perform this operation.
 - If you have installed the new X.509v3 certificates or are currently on a release that includes the fix, and are downgrading to one of the fixed releases (10.4.3.7, 10.5.0.9, 10.5.1.9, 10.5.2.6 or later), no action is required.

Table 8. Downgrade OS10

Task	Section
Downgrade to OS10 release 10.5.0.9 or earlier	Downgrade to OS10 release 10.5.0.9 or earlier
Downgrade to OS10 release 10.5.1.9 or later	Downgrade to OS10 release 10.5.1.9 or later
Rollback to OS10 release 10.5.0.9 or earlier	Rollback from OS10 release 10.5.2.0 or later to 10.5.0.9 or earlier
Rollback to OS10 release 10.5.1.9 or later	Rollback from OS10 release 10.5.2.0 or later to 10.5.1.9 or later

- NOTE:** Downgrade is not supported for IOMs in the fabric (PowerEdge MX deployments).

Downgrade to OS10 release 10.5.0.9 or earlier

In this example, the OS10 switch runs the 10.5.1.0 software and the following procedure downgrades the system to Release 10.5.0.9.

- NOTE:**
 - If the version that you are downgrading to is present in the system as the standby image, you can rollback to that release without losing configuration or license data. To view the standby image version, use the `show boot detail` command. For more information, see the [Rollback from OS10 release 10.5.2.0 or later to 10.5.0.9 or earlier](#) section.
 - If the image that you are downgrading to is newly installed using the `image install` command, backup of the original configuration data will not be available. The system boots with the default configuration. If you have a copy of the backup configuration file (.xml) obtained from the earlier release that you are downgrading to, apply the saved configuration and license files as described the following procedure.

Prerequisites

Obtain a backup of the configuration data. Ensure that you have a copy of the license files. Reapply the configuration data and licenses files after you reload the 10.5.0.9 or earlier image.

1. Back up the current running configuration to an external storage.

```
OS10# copy running-configuration scp://userid:passwd@hostip/filepath/10.5.2.0-running-configuration.txt
```

2. Back up the startup configuration (startup.xml) to an external storage.

```
OS10# write memory
OS10# copy config://startup.xml scp://userid:passwd@hostip/filepath/10.5.2.0-startup.xml
```

3. Download the OS10 binary image for Release 10.5.0.9 from a local server using the `image download server-filepath/filename` command in EXEC mode; for example:

```
OS10# image download scp://admin:passwd@10.1.1.1/home/admin/images/OS10EE.bin
```

4. (Optional) View the current software download status in EXEC mode.

```
OS10# show image status
```

5. Install the OS10 standby image using the `image install file-url` command in EXEC mode, where *filename* is the name of the image file that was downloaded with the `image download` command; for example:

```
OS10# image install image://OS10EE.bin
```

6. (Optional) View the status of the software installation in EXEC mode.

```
OS10# show image status
Image Upgrade State:      idle
=====
File Transfer State:      transfer-success
-----
State Detail:             Completed: No error
Task Start:               2019-11-19T06:55:44Z
Task End:                 2019-11-19T06:55:53Z
Transfer Progress:       100 %
Transfer Bytes:           469343880 bytes
File Size:                469343880 bytes
Transfer Rate:            67812 kbps

Installation State:       install-failed
-----
State Detail:             Failed: Downgrade image staged for clean install. Reload to
downgrade.
Task Start:               2019-11-19T06:55:53Z
Task End:                 2019-11-19T06:56:01Z
```

NOTE:

- During this stage, the `show boot detail` command displays the details of the previous image that was installed. The `boot system active | standby` command is not applicable during this state.
- If you install a new image using the `image install` command, the current staging image is replaced with the new image that you have installed and you cannot downgrade to the previous version.

7. Reload the new software image in EXEC mode. This command performs a fresh installation of Release 10.5.0.9. Release 10.5.0.9 is installed as both the active and standby images.

```
OS10# reload
```

8. Use the `show version` command in EXEC mode to verify that the downloaded OS10 image is installed as the current running version.

```
OS10# show version
Dell EMC Networking OS10 Enterprise
Copyright (c) 1999-2019 by Dell Inc. All Rights Reserved.
OS Version: 10.5.0.9
Build Version: 10.5.0.270
Build Time: 2019-07-29T23:35:01+0000
System Type: S4148F-ON
```

```
Architecture: x86_64
Up Time: 1 day 00:54:13
```

9. If the saved configuration from Release 10.5.0.9 (or the earlier release that you are downgrading to) is available, apply the saved configuration and license files, and reload the switch.

```
OS10# copy scp://userid:passwd@hostip/filepath/10.5.0.9-startup.xml config://
startup.xml
```

```
OS10# license install scp://user:passwd@hostip/0A900Q2-NOSEnterprise-License.xml
```

```
OS10# reload
```

- NOTE:** While reloading, if the CLI prompts to save, select `no` for the save option. Selecting `yes` overrides the configuration that was copied earlier.
- NOTE:** If you have made any nondefault hardware settings before the downgrade, after you downgrade and restore the configuration, use the `show hardware` command to check if your settings are applied. If not, save and reload the box for the settings to be applied.

If you have a nondefault switch port profile configured, this setting might not be applied. Apply the switch port profile configuration first, save the configuration, and then restore the configuration file.

10. If the saved configuration file from Release 10.5.0.9 (or the earlier release) that you are downgrading to is not available, apply the backup text configuration (.txt) that was obtained earlier. Ensure that the backup configuration text file does not have unsupported commands (commands that are introduced in later releases). If unsupported commands are present in the text file, the system reports an error. If any of the configurations require a reload, you might have to reload the switch.

```
OS10# copy scp://userid:passwd@hostip/filepath/backup-running-configuration.txt
running-configuration
OS10# write memory
OS10# reload
```

- NOTE:** After downgrading OS10 from 10.5.1.x or later to 10.5.0.9 or earlier version, the following images are available on the switch:

- Image A: 10.5.0.9 or earlier (active)
- Image B: N/A

During this state, you must not use the `boot system standby` command and `reload` as the switch might get stuck in the GRUB shell.

Use the `image copy active-to-standby` command from the OS10 CLI to copy the active image to become the standby image as well.

Downgrade to OS10 release 10.5.1.x or later

In this example, the OS10 switch runs the 10.5.2.0 software and the following procedure downgrades the system to Release 10.5.1.9.

- NOTE:**
- If the version that you are downgrading to is present in the system as the standby image, you can rollback to that release without losing configuration or license data. To view the standby image version, use the `show boot detail` command. For more information, see the [Rollback from OS10 release 10.5.2.0 or later to 10.5.1.9 or later](#) section.
 - If the image that you are downgrading to is newly installed using the `image install` command, backup of the original configuration data will not be available. The system boots with the default configuration. If you have a copy of the backup configuration file (.xml) obtained from the earlier release that you are downgrading to, apply the saved configuration and license files as described in the following procedure. Ensure that you back up the configuration data to an external storage even when you downgrade from a later version to an earlier version within the same release series.

Prerequisites

Obtain a backup of the configuration data. Ensure that you have a copy of the license files. Reapply the configuration data and licenses files after you reload to 10.5.1.9.

1. Back up the current running configuration to an external storage.

```
OS10# copy running-configuration scp://userid:passwd@hostip/filepath/10.5.2.0-running-configuration.txt
```

2. Back up the startup configuration (`startup.xml`) to an external storage.

```
OS10# write memory
OS10# copy config://startup.xml scp://userid:passwd@hostip/filepath/10.5.2.0-startup.xml
```

3. Download the OS10 binary image for Release 10.5.1.9, also called the standby image, from a local server using the `image download server-filepath/filename` command in EXEC mode; for example:

```
OS10# image download scp://admin:passwd@10.1.1.1/home/admin/images/OS10EE.bin
```

4. (Optional) View the current software download status in EXEC mode.

```
OS10# show image status
```

5. Install the OS10 standby image using the `image install file-url` command in EXEC mode, where `filename` is the name of the image file that was downloaded with the `image download` command; for example:

```
OS10# image install image://OS10EE.bin
```

6. (Optional) View the status of the software installation in EXEC mode.

```
OS10# show image status
Image Upgrade State:      idle
=====
File Transfer State:     transfer-success
-----
State Detail:            Completed: No error
Task Start:              2019-11-19T06:55:44Z
Task End:                2019-11-19T06:55:53Z
Transfer Progress:       100 %
Transfer Bytes:          469343880 bytes
File Size:               469343880 bytes
Transfer Rate:           67812 kbps

Installation State:      install-success
-----
State Detail:            Completed: Success
Task Start:              2019-11-19T06:55:53Z
Task End:                2019-11-19T06:56:01Z
```

7. Use the `show boot detail` command to view the standby image. Change the next boot image to the standby image in EXEC mode. Reload the device. The device comes up with 10.5.1.9 software image.

```
OS10# show boot detail
```

```
OS10# boot system standby
```

```
OS10# reload
```

8. Use the `show version` command in EXEC mode to verify that the downloaded OS10 image is installed as the current running version.

```
OS10# show version
Dell EMC Networking OS10 Enterprise
Copyright (c) 1999-2019 by Dell Inc. All Rights Reserved.
OS Version: 10.5.1.9
Build Version: 10.5.1.9.124
Build Time: 2020-02-12T02:34:02Z
System Type: S4148F-ON
```

```
Architecture: x86_64
Up Time: 1 day 00:54:13
```

- If the saved configuration from Release 10.5.1.9 (or the later release to which you are downgrading to) is available, apply the saved configuration and license files, and reload the switch.

```
OS10# copy scp://userid:passwd@hostip/filepath/10.5.1.9-startup.xml config://
startup.xml
```

```
OS10# license install scp://user:passwd@hostip/0A900Q2-NOSEnterprise-License.xml
```

```
OS10# reload
```

- NOTE:** While reloading, if the CLI prompts to save, select `no` for the save option. Selecting `yes` overrides the configuration that was copied earlier.
- NOTE:** If you have made any non-default hardware settings before the downgrade, after you downgrade and restore the configuration, use the `show hardware` command to check if your settings are applied. If not, save and reload the box for the settings to be applied.

On the S4100-ON Series switches, if you have a non-default switch port profile configured, this setting might not be applied. Apply the switch port profile configuration first, save the configuration, and then restore the configuration file.

- If the saved configuration file from Release 10.5.1.9 (or the later release) that you are downgrading to is not available, apply the backup text configuration (.txt) taken earlier. Ensure that the backup configuration text file does not have any unsupported commands (commands that are introduced in later releases). If unsupported commands are present in the text file, the system reports an error. If any of the configurations require a reload, you might have to reload the switch.

```
OS10# copy scp://userid:passwd@hostip/filepath/backup-running-configuration.txt
running-configuration
OS10# write memory
OS10# reload
```

Rollback from OS10 release 10.5.2.0 or later to 10.5.0.9 or earlier

To move to an earlier release, use the rollback script that is bundled with your OS10 software image. Using the rollback script retains the earlier configuration and license information. You can use the rollback option only when the previous image is available in the system as the standby image. To view the version of the standby image, use the `show boot detail` command.

- NOTE:** The rollback script reboots the OS10 switch immediately. The system removes any configuration changes that you have made in the new release when you run the rollback script.

To roll back, from the Linux shell prompt, enter:

```
OS10# system bash
bash (OS10) $ sudo os10-rollback-to-old-image
```

- NOTE:** After rollback is complete, the system comes up with the previous release. However, the standby image becomes nonbootable. To boot using the standby image, you have to install the image again using the `image install` command.

Rollback from OS10 release 10.5.2.0 or later to 10.5.1.9 or later

The following rollback procedure retains the earlier configuration and license information. You can use the rollback option only when the previous image is available in the system as the standby image. To view the version of the standby image, use the `show boot detail` command.

If the version that you are downgrading to is present in the system as the standby image, you can rollback to that release without losing any configuration or license data.

1. Use the `show boot detail` command to view the standby image.

```
OS10# show boot detail
Current system image information detail:
=====
Type: Node-id 1
Boot Type: Flash Boot
Active Partition: B
Active SW Version: 10.5.2.0
Active SW Build Version: 10.5.2.0
Active Kernel Version: Linux 4.9.168
Active Build Date/Time: 2020-03-07T11:43:33+0000
Active Partition: B
Standby Partition: A
Standby SW Version: 10.5.1.0
Standby SW Build Version: 10.5.1.0.200
Standby Build Date/Time: 2020-03-07T23:35:01Z
Next-Boot: standby[A]
```

2. Change the next boot image to the standby image in EXEC mode.

```
OS10# boot system standby
```

3. Reload the new software image in EXEC mode.

```
OS10# reload
```

Update ONIE and ONIE firmware

The following procedure describes how to update ONIE and ONIE firmware from the OS10 CLI. For other methods of updating ONIE and ONIE firmware, see the [Platform-specific ONIE Firmware Updater Release Notes](#).

Before you begin

- Download the latest ONIE and Firmware Updater software.
 - Go to the [Dell Support Site](#).
 - Enter the platform name in the Search box. For example, PowerSwitch S5212F-ON.

NOTE: The platforms and versions used in the following tasks are for illustrative purposes only. See the [Platform-specific ONIE Firmware Updater Release Notes](#) for the latest recommended versions.

The platform-specific support page appears.

- Click the **Drivers & Downloads** tab.
 - Download the ONIE and Firmware Updater software.
- Back up the startup configuration and running configuration to a remote location before you upgrade ONIE and ONIE firmware.

```
OS10# copy config://startup.xml scp://username@server/filepath/nodename-backupfile-startup.xml
```

```
OS10# copy running-configuration scp://username@server/filepath/nodename-backup-runconfig.txt
```

- NOTE:** If you are updating ONIE and ONIE firmware on a pair of VLT nodes, update ONIE and ONIE firmware on one VLT peer node (Peer1) first before you update the other VLT peer node (Peer 2). Updating one VLT node at a time ensures that traffic continues to flow through one of the VLT peers when the other one is being updated.

Update ONIE

- Download the ONIE image to the OS10 switch.

```
OS10# image download scp://username@server//filepath/onie-updater-x86_64-dellemc_s5200_c3538-r0.3.40.1.1-6
password: *****
Download started.
```

- Check the image download status.

```
OS10# show image status
Image Upgrade State:      idle
=====
File Transfer State:      transfer-success
-----
State Detail:             Completed: No error
Task Start:               2021-09-24T06:49:59Z
Task End:                 2021-09-24T06:50:07Z
Transfer Progress:        100 %
Transfer Bytes:           18536311 bytes
File Size:                18536311 bytes
Transfer Rate:            2248 kbps
```

Use the `dir image` command to check the downloaded image.

```
OS10# dir image

Directory contents for folder: image
Date (modified)          Size (bytes)  Name
-----
```

```
2021-09-24T06:50:07Z 18536311 onie-updater-x86_64-dellemc_s5200_c3538-
r0.3.40.1.1-6
```

3. Stage the ONIE software using the `image install` command.

```
OS10# image install image://onie-updater-x86_64-dellemc_s5200_c3538-r0.3.40.1.1-6
Install started.
```

Do not stage any other image update until the ONIE software update is complete.

Use the `show image firmware` command to view the staged updates.

4. Save the configuration and reload the switch to install the ONIE software.

```
OS10# reload
```

It takes about two to three minutes for the ONIE software update to complete, and the system boots after that.

NOTE: During reload, the system goes into ONIE Update Mode to update the ONIE software and reloads once after completing the update successfully.

5. After the device is up, check the ONIE version using the following command:

```
OS10# system "/mnt/onie-boot/onie/tools/bin/onie-version"
ONIE version : 3.40.1.1-6
```

Update ONIE firmware

1. Download the firmware update to the OS10 switch.

```
OS10# image download scp://username@serverip//filepath/onie-firmware-x86_64-
dellemc_s5200_c3538-r0.3.40.5.1-20.bin
password: *****
Download started.
```

2. Check the image download status.

```
OS10# show image status
Image Upgrade State: download
=====
File Transfer State: download
-----
State Detail: In progress
Task Start: 2021-09-24T07:06:04Z
Task End: 0000-00-00T00:00:00Z
Transfer Progress: 100 %
Transfer Bytes: 56688640 bytes
File Size: 56731511 bytes
Transfer Rate: 3988 kbps
```

Use the `dir image` command to check the downloaded image.

```
OS10# dir image

Directory contents for folder: image
Date (modified) Size (bytes) Name
-----
2021-09-24T07:06:18Z 56731511 onie-firmware-x86_64-dellemc_s5200_c3538-
r0.3.40.5.1-20.bin
```

3. Stage the ONIE firmware updater software using the `image install` command.

```
OS10# image install image://onie-firmware-x86_64-dellemc_s5200_c3538-r0.3.40.5.1-
20.bin
Install started.
```

Use the `show image firmware` command to view the staged updates.

4. Save the configuration and reload the switch.

```
OS10# reload
```

It takes about 25 minutes for the firmware update to complete, and the system boots after that.

NOTE: During reload, the system goes into ONIE Update Mode to update the firmware components and reloads once after completing the update successfully.

5. After the device is up, check the firmware version using the following command:

```
OS10# show system

BIOS                : 3.40.0.9-11
FPGA                : 3.0
BMC                 : 1.05
System CPLD        : 0.8
Slave CPLD 1       : 1.0
Slave CPLD 2       : 1.0
Slave CPLD 3       : 0.0
Slave CPLD 4       : 0.0
```

For the S5200-ON platform, check the PCIe Requirements under the [Platform-specific prerequisites](#) section and proceed with [upgrading OS10](#).

Upgrade PCIe firmware from DIAG OS

This procedure is applicable only for the S5200-ON series switches.

NOTE: Do not update the same PCIe firmware version over itself as this action may cause unexpected system behaviors.

Before you begin

Accessing the EDA DIAG OS requires root user privileges. Ensure that you obtain the root user credentials.

1. Reload the switch in EXEC mode and watch for the ONIE boot menu.

```
OS10# reload
```

2. Use the arrow keys to scroll and select *ONIE.

```
GNU GRUB  version 2.02
+-----+
| OS10-A |
| OS10-B |
| *ONIE  |
|        |
|        |
+-----+
```

The GRUB menu appears.

3. Use the arrow keys to scroll and select *EDA-DIAG.

```
+-----+
| ONIE: Install OS |
| ONIE: Rescue     |
| ONIE: Uninstall OS |
| ONIE: Update ONIE |
| ONIE: Embed ONIE  |
| *EDA-DIAG        |
+-----+
```

The EDA DIAG login prompt appears.

4. Enter the root username and password.

```
dellemc-diag-os login: root
Password: *****
```

5. Copy the PCIe firmware .bin file to the DIAG OS partition.

```
root@dellemc-diag-os:/etc/dn/diag# ifconfig eth0 management-ip

root@dellemc-diag-os:/etc/dn/diag# route add default gw default-gw-ip

root@dellemc-diag-os:/etc/dn/diag# wget scp://xx.xx.xx.xxx/pcieg3fw.bin
--2020-08-12 06:37:32--  scp://xx.xx.xx.xxx/pcieg3fw.bin
=> 'pcieg3fw.bin'
Connecting to xx.xx.xx.xxx:xx... connected.
Logging in as anonymous ... Logged in!
==> SYST ... done. ==> PWD ... done.
==> TYPE I ... done. ==> CWD not needed.
==> SIZE pcieg3fw.bin ... 30720
==> PASV ... done. ==> RETR pcieg3fw.bin ... done.
Length: 30720 (30K) (unauthoritative)
pcieg3fw.bin 0%[ ] 0 --.-KB/s
```

```
pcieg3fw.bin 100%[=====>] 30.00K --.-KB/s in 0.001s
2020-08-12 06:37:32 (32.2 MB/s) - 'pcieg3fw.bin' saved [30720]
```

6. Enter the `nputool -d -i` command.

```
root@dellemc-diag-os:/etc/dn/diag# nputool -d -i
linux-user-bde:new probed device unit 0 dev_no 0 _ndevices 1
DMA pool size: 33554432
PCI unit 0: Dev 0xb873, Rev 0x01, Chip BCM56873_A0, Driver BCM56870_A0
sysconf_probe successful
global_sal_config successful
*** 1 BCM devices are detected
SOC unit 0 attached to PCI device BCM56873_A0
Loading M0 Firmware located at /etc/dn/diag/linkscan_led_fw.bin
Loading M0 Firmware located at /etc/dn/diag/custom_led.bin
*** unit 0: ports capable of limited speed range cut-thru
0:bcmi_xgs5_bfd_init: uKernel BFD application not available
Current mode is now ESW
Diag NPU initialization over
Enter 'exit' to exit out of bcm shell
Inside bcm shell
BCM.0>
```

The system enters the BCM shell.

7. Enter the `pciephy fw load pcieg3fw.bin` command.

```
BCM.0> pciephy fw load pcieg3fw.bin
0:soc_flash_init: Flash supported ID = 0x20
Opening file: pcieg3fw.bin
Updating PCIE firmware
.....
..... Done
PCIE firmware updated successfully. Please reset the system...
BCM.0>
```

8. Enter `Exit` to return to the DIAG OS prompt.

```
BCM.0> exit
root@dellemc-diag-os:#
```

9. Reboot the switch.

```
root@dellemc-diag-os:# reboot
```

PCIe firmware upgrade is complete. The system boots with OS10 Release 10.5.0.9.

Upgrade PCIe firmware from OS10 hshell

Use this option to upgrade PCIe firmware only if console access is not available.

NOTE: This PCIe firmware update applies only to S5200-ON switches running OS10 software. Do not attempt this procedure for any third-party Network Operating System (NOS).

NOTE: Do not update the same PCIe firmware version over itself as this action may cause unexpected system behaviors.

Before you begin

- Accessing the OS10 hshell requires root user privileges. Ensure that you obtain the root user credentials.
- Ensure that you shut down all the ports on the OS10 switch.

This firmware update method does not require serial access or a USB port. To update the PCIe firmware from the OS10 hshell:

1. Log in to the switch.
2. Copy the firmware to a known location; for example, /home/admin.

```
OS10# system "sudo -i"
[sudo] password for admin:

root@OS10# cd /home/admin

root@OS10:/home/admin# copy scp://userid:passwd@hostip/filepath/pcieg3fw.bin .

root@OS10:/home/admin# ls
pcieg3fw.bin
```

3. Enter the OS10 hshell.

```
root@OS10:/home/admin# hshell
Welcome to the NPU Shell
type ::exit to exit the shell and ::[npu] to change the default npu
SAI.0> SAI.0> SAI.0>
SAI.0>
SAI.0> pwd
Working Directory: /
SAI.0> cd /home/admin
SAI.0>
SAI.0> ls
pcieg3fw.bin
SAI.0>
```

4. Enter the `pciephy fw load pcieg3fw.bin` command.

```
SAI.0> pciephy fw load pcieg3fw.bin
0:soc_flash_init: Flash supported ID = 0x20
Opening file: pcieg3fw.bin
Updating PCIE firmware
..... Done
PCIE firmware updated successfully. Please reset the system...
SAI.0>
```

If you see an error message similar to the following, contact Technical Support.

```
SAI.0> pciephy fw load pcieg3fw.bin
0:soc_flash_init: Flash not supported = 0x59
Error: Init SPI flash speed = 31250000, mode =3
SAI.0>
```

5. Enter `Exit` to return to the OS10 CLI.

```
SAI.0> ::exit  
OS10#
```

6. Reload the switch.

```
OS10# reload
```

PCIe firmware upgrade is complete. The system boots with OS10 Release 10.5.0.9.

Links to ONIE Firmware Updater and DIAG OS Release Notes

This appendix lists the hardware platforms that SmartFabric OS10 supports and provides links to the respective ONIE Firmware Updater and DIAG OS Release Notes

Table 9. Links to ONIE Firmware Updater and DIAG OS Release Notes

Platform	ONIE Firmware Release Notes	DIAG OS and Tools Release Notes
S3048-ON	PowerSwitch S3048-ON Firmware Updater Release Notes	Dell EMC S3048-ON and S4048-ON Troubleshooting Guide
S4048-ON	S4048-ON Firmware Updater Release Notes	Dell EMC S3048-ON and S4048-ON Troubleshooting Guide
S4048T-ON	S4048T-ON Firmware Updater Release Notes	Open Networking Hardware Diagnostic Guide
<ul style="list-style-type: none"> • S4112F-ON • S4112T-ON 	Dell EMC PowerSwitch S4112-ON Series ONIE Firmware Updater Release Notes	Dell EMC PowerSwitch S4112-ON Series DIAG OS and Tools Release Notes
<ul style="list-style-type: none"> • S4128F-ON • S4128T-ON • S4148F-ON • S4148FE-ON • S4148T-ON • S4148U-ON 	Dell EMC PowerSwitch S4100-ON Series ONIE Firmware Updater Release Notes	Dell EMC PowerSwitch S4100-ON Series DIAG OS and Tools Release Notes
<ul style="list-style-type: none"> • S4248FB-ON • S4248FBL-ON 	S4200-ON Series ONIE Firmware Updater Release Notes	S4200-ON Series DIAG OS and Tools Release Notes
<ul style="list-style-type: none"> • S5232F-ON • S5248F-ON • S5296F-ON • S5212F-ON • S5224F-ON 	Dell EMC PowerSwitch S5200F-ON Series ONIE Firmware Updater Release Notes	Dell EMC PowerSwitch S5200F-ON Series DIAG OS and Tools RNs
S6010-ON	Dell EMC PowerSwitch S6010-ON Firmware Updater Release Notes	Open Networking Hardware Diagnostic Guide
Z9100-ON	Z9100-ON ONIE Firmware Updater Release Notes	Open Networking Hardware Diagnostic Guide
Z9264F-ON	Dell EMC PowerSwitch Z9264F-ON ONIE Firmware Updater Release Notes	Z9264F-ON DIAG OS and Tools Release Notes
Z9332F-ON	Dell EMC PowerSwitch Z9332F-ON ONIE Firmware Updater Release Notes	Dell EMC PowerSwitch Z9332F-ON DIAG OS and Tools Release Notes
N3248TE-ON	Dell EMC PowerSwitch N3200-ON Series ONIE Firmware Updater Release Notes	Dell EMC PowerSwitch N3200-ON Series OS and Tools Release Notes
<ul style="list-style-type: none"> • MX5108N • MX9116N 	MX9116n MX5108n MX7116n IOM Release Notes	MX9116n and MX5108n DIAG OS and Tools Release Notes
Z9432F-ON	Dell EMC PowerSwitch Z9432F-ON ONIE Firmware Updater Release Notes	Dell EMC PowerSwitch Z9432F-ON DIAG OS and Tools Release Notes

Frequently asked questions

This appendix provides answers to frequently asked questions about OS10 installation, upgrade, and downgrade procedures.

How long does it take to upgrade a single switch?

It takes from 20 to 45 minutes to upgrade a single switch depending on the switch platform and other parameters. Use the `show image status` command to view the status of the upgrade.

How long does it take to upgrade a pair of VLT nodes?

Depending on the size of your deployment, it can take from 20 minutes to one hour to upgrade a pair of VLT nodes.

Will there be a production outage during an upgrade? If yes, for how long?

In a VLT setup, you do not see any production outage. If your OS10 nodes are not part of a VLT setup, you might need a downtime of 30 minutes.

Which mode of file transfer should I use?

The type of file transfer that you use depends on your environment. OS10 supports the following file transfer methods:

- HTTP
- FTP
- SCP
- SFTP
- TFTP
- USB

Dell Technologies recommends copying the image to the switch using the `image download` command and then install it.

What is the preferred method to upgrade IOMs in the fabric?

Use the OME-M console to upgrade the IOMs in the fabric. The upgrade is carried out using a Dell Update Package (DUP). A DUP is a self-contained package format that updates a single element on a system. Download the OS10 DUP and follow the instructions in the OME-M User's Guide.

Which application should I use to extract the .tar file?

Use any standard extraction utility to unpack the .tar file. Ensure that you check the SHA-256 checksum and ensure that the image is intact.

What file system should I use for the USB drive?

Use a 4-GB or larger USB drive in FAT32 format.

Is reloading a switch the same as power cycling it?

During upgrade of a hardware component such as BIOS or CPLD, the switch automatically power cycles as part of the upgrade process. This process is different from a switch reload. To manually power cycle a switch:

1. Turn off power on the switch or unplug the device from the power source manually. Alternatively, use remote power control to turn off the switch.
2. Wait for two to three minutes.
3. Turn the device back on or plug it into the power source.