

Dell EMC Networking Virtual Edge Platform 1405 Series

Getting Started Guide

Notes, cautions, and warnings

 **NOTE:** A NOTE indicates important information that helps you make better use of your product.

 **CAUTION:** A CAUTION indicates either potential damage to hardware or loss of data and tells you how to avoid the problem.

 **WARNING:** A WARNING indicates a potential for property damage, personal injury, or death.

Chapter 1: About this Guide	4
Related documents.....	4
Information symbols.....	5
Chapter 2: Site Preparations	6
Site selection.....	6
Chassis mounting.....	6
Fans and airflow.....	10
Power.....	10
Storing components.....	10
Chapter 3: VEP1405 Series Installation	11
Unpack.....	11
Platform power-up.....	11
Chapter 4: Specifications	12
Chassis physical design.....	12
Safety standards and compliance agency certifications.....	17
Product recycling and disposal.....	17
Agency compliance.....	18
USA Federal Communications Commission statement.....	18
Industry Canada Statement.....	19
Radiocommunication equipment compliance for Thailand.....	19
Brasil – Aviso da Anatel.....	20
European Union EMC directive conformance statement.....	21
Japan VCCI compliance for Class A equipment.....	21
Korean certification of compliance.....	22
Mexico certification of compliance.....	23
Taiwanese certification of compliance.....	23
Singapore certification of compliance.....	23
Chapter 5: Support	24

About this Guide

This guide provides site preparation recommendations, step-by-step procedures for rack and desk mounting, inserting modules, and connecting to a power source for the Dell EMC Networking Virtual Edge Platform (VEP) 1405 series of systems.

CAUTION: To avoid electrostatic discharge (ESD) damage, wear grounding wrist straps when handling this equipment.

WARNING: Only trained and qualified personnel can install this equipment. Read this guide before you install and power up this equipment. This equipment contains one power cable. Disconnect the power cable before servicing.

WARNING: This equipment supports optical transceivers, which comply with the limits of Class 1 laser radiation.



Figure 1. Class 1 laser product tag

WARNING: When the SFP transceiver is plugged in and a cable is not connected, visible and invisible laser radiation may be emitted from the aperture of the optical transceiver ports. Avoid exposure to laser radiation, and do not stare into open apertures.

Table 1. Regulatory compliance information for the VEP1405 series of systems

Marketing model number	Regulatory model number	Regulatory type number	Remarks
VEP1425/VEP1425N	E42W	E42W001	4-core, 120G SSD
VEP1445/VEP1445N	E42W	E42W001	8-core, 240G/960G SSD
VEP1485/VEP1485N	E42W	E42W001	16-core, 240G/2TB SSD

NOTE: The VEP1425N, VEP1445N, and VEP1485N system models do not include wireless or Bluetooth capabilities.

Related documents

For information about the Virtual Edge Platform 1405 (VEP1405) series of systems, see the following documents:

- *Dell EMC Networking Virtual Edge Platform (VEP) 1405 Series Operating System Installation Guide*
- *Dell EMC Networking Virtual Edge Platform (VEP) 1405 Series Diag OS and Tools Release Notes*
- *Dell EMC Networking Virtual Edge Platform (VEP) 1405 Series Technology Guide*

NOTE: For the most recent documentation, see the support site: <https://www.dell.com/support>.

Information symbols

This book uses the following information symbols:

 **NOTE:** The **Note** icon signals important operational information.

 **CAUTION:** The **Caution icon** signals information about situations that could result in equipment damage or loss of data.

 **NOTE:** The **Warning** icon signals information about hardware handling that could result in injury.

 **NOTE:** The **ESD Warning** icon requires that you take electrostatic precautions when handling the device.

Site Preparations

The Virtual Edge Platform 1405 series of systems, or VEP1405, are a universal customer premise equipment (uCPE) devices. The VEP1405 series connects the service provider edge or small to medium branch locations to the cloud, to host virtual network functions.

For more information about VEP1405 series specifications, see the [Chassis physical design](#) section.

Site selection

Ensure that the area where you install your platform meets the following safety requirements:

- Near an adequate power source
- Connected to a properly grounded power outlet
- ⚠ **WARNING: The VEP1405 series of systems AC power cord must be connected to a socket outlet that has properly wired earth ground.**
- Environmental—platform location—continuous temperature range is 0–40°C (32–104°F)
- Operating humidity:
 - 5% to 85% (RH), noncondensing continuously
 - 5% to 90% (RH), noncondensing Short term (< 1% of operational hour per year)
- In a dry, clean, well-ventilated, and temperature-controlled room, away from heat sources such as hot air vents or direct sunlight
- Away from sources of severe electromagnetic noise
- In a location that enables the VEP1405 series of systems to be out of direct view within the workplace

For more information about platform storage and environmental temperatures, see [Specifications](#).

Chassis mounting

The VEP1405 series supports the following mounting options:

- Desktop placement (rubber feet)
- Wall mount placement
- Rack-mounted using the optional rack mount tray

Desktop placement

The VEP1405 series includes four rubber feet that provide secure and stable placement of the unit on a flat surface.

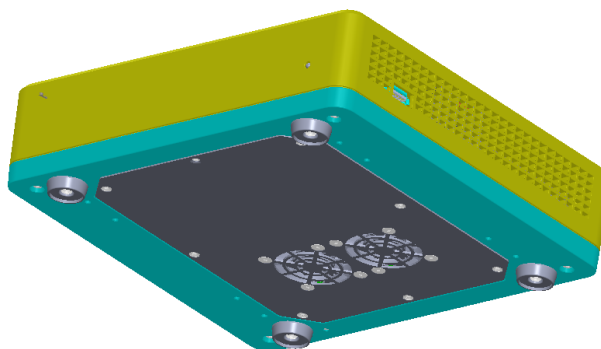

Figure 2. VEP1405 series desktop placement

Wall mount installation

The VEP1405 series includes the hardware that is required for wall mount installation. Using a torque screwdriver, affix the wall mount brackets to the VEP1405 series using the four M3 screws included.

NOTE: When driving the screws into the bracket and VEP1405 series unit, verify that **5 lb-in** is the achieved torque setting.

NOTE: If mounting the VEP1405 series to the wall using the wall mount bracket provided, removal of the rubber feet from the bottom of the VEP1405 series unit is not necessary.

The VEP1405 series of systems include a wall mount bracket with cross-shaped cutout for the mounting screws. The wall mount bracket includes cross-shaped cutouts for the mounting screws.

Wall mount bracket with cross-shaped cutout for the mounting screws

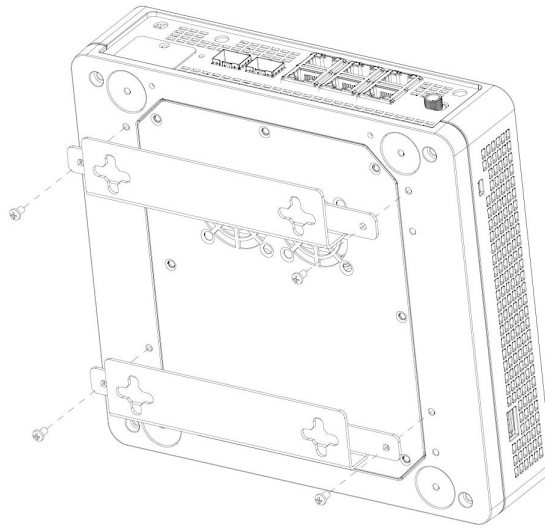

Figure 3. VEP1405 series wall mount installation - cross-shaped cutout

To mount the VEP1405 series unit to the wall using the wall mount bracket provided, you must first anchor the screws into the wall surface. Depending on the type of wall surface, use the M3 screw and anchor to ensure a secure installation. The recommended M3 screw dimensions are as follows:

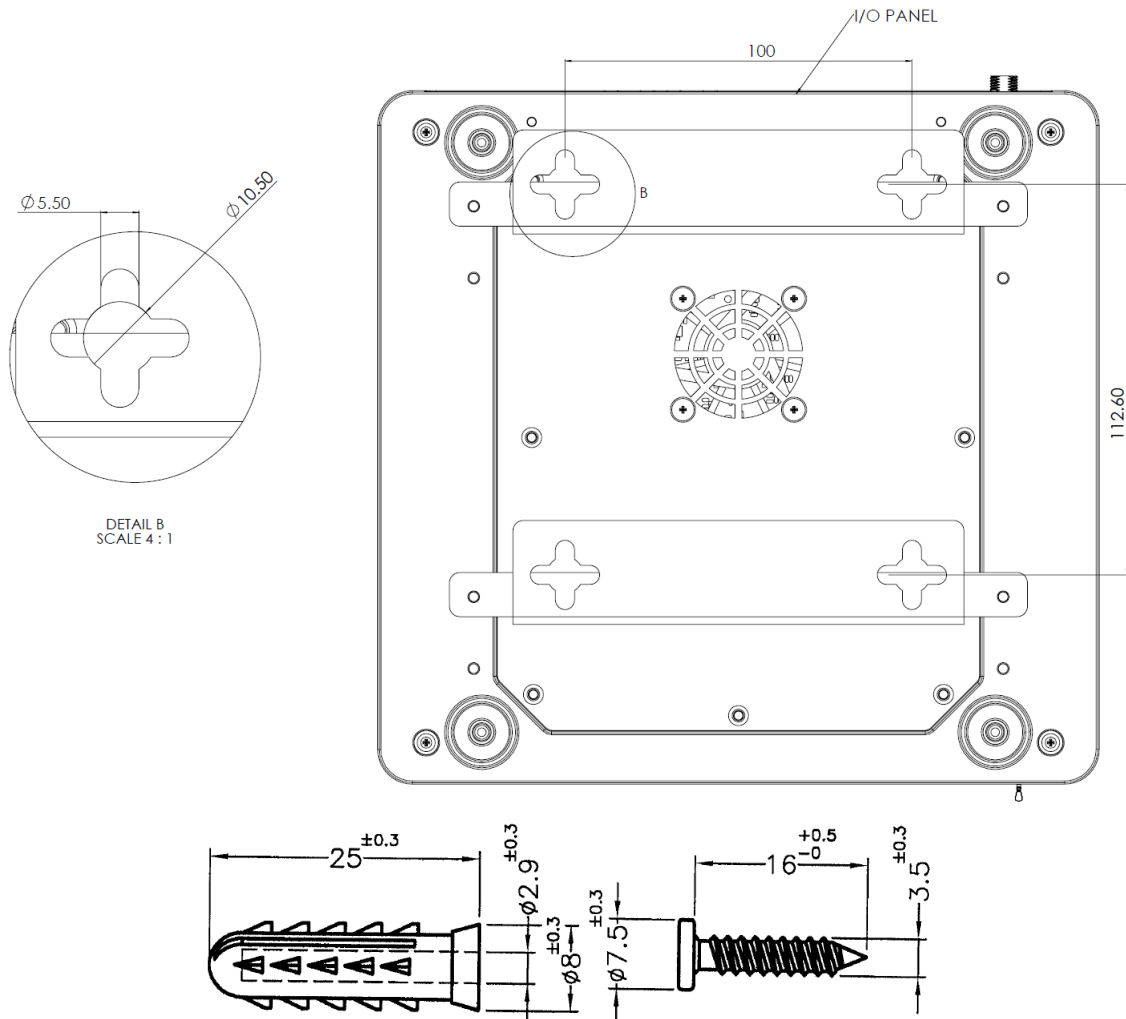

Figure 4. VEP1405 series wall mount, installation anchor, and screw dimensions

NOTE: Before mounting the VEP1405 series to the wall, verify that the wall surface is strong enough to support a firm installation of the unit and can withstand the weight of the unit, power cable, and network cabling.

Using the measurements provided in the following diagram, use the measurement in the red box to mark the distance between the two installation points:

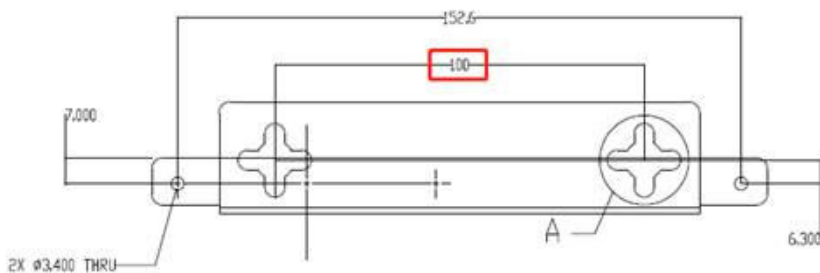

Figure 5. VEP1405 series M3 screw installation points

After the brackets have been attached to the VEP1405 series unit and the screws that are mounted into the wall, place the brackets over the screws and slide the unit to one side to secure the unit in place.

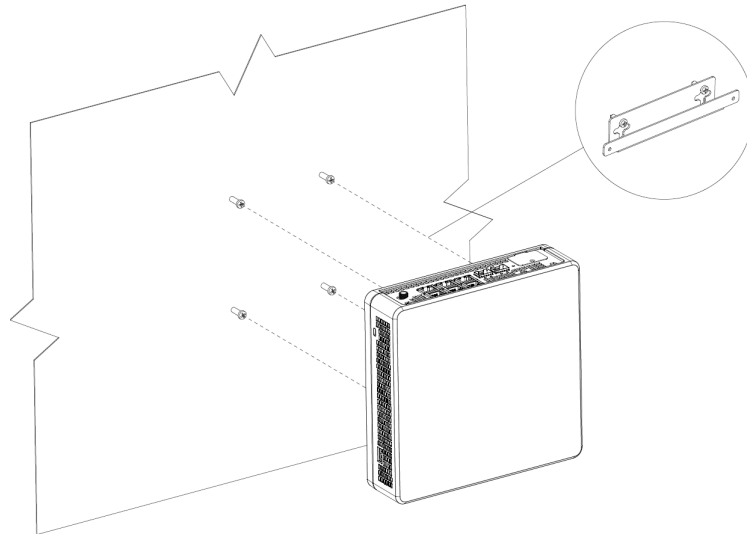

Figure 6. VEP1405 series wall mount bracket installation - cross-shaped cutout

Rack-mounted installation

As an option, the VEP1405 series can be mounted to a dual rack mount tray. Purchased separately, you can install the VEP1405 series to the dual rack mount tray using a torque screwdriver and the eight M3 screws included.

- ⓘ **NOTE:** When driving the screws into the bracket and VEP1405 series unit, verify that **5 lb-in** is the achieved torque setting.
- ⓘ **NOTE:** If mounting the VEP1405 series to a dual rack mount tray, removal of the rubber feet from the bottom of the VEP1405 series unit is not necessary.

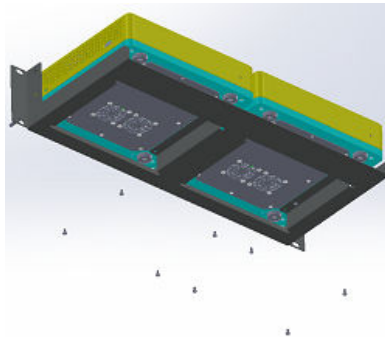

Figure 7. VEP1405 series rack mount installation

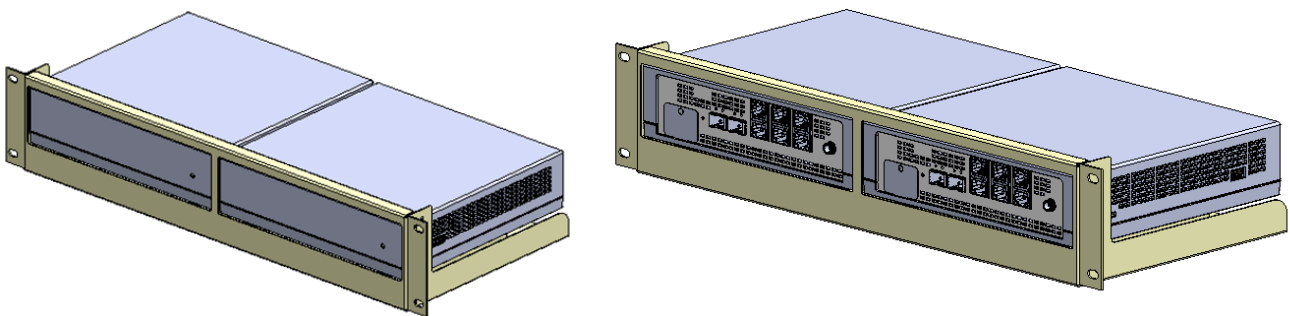

Figure 8. VEP1405 series rack installation - front and back view

Fans and airflow

Fan installation is done as part of the factory install and is based on the stock keeping unit (SKU) type. The VEP1405 series of systems support a DC fan unit with fan airflow starting from the bottom of the unit:

- Four core unit with single fan
- Eight core unit with two fans
- Sixteen core unit with two fans

Position the unit in a well ventilated environment with clearance around the exhaust vents. The fan speed varies based on internal temperature monitoring. The platform never intentionally turns off the fans.

⚠ CAUTION: The fans are not field-replaceable.

⚠ CAUTION: For thermal considerations, do not stack the VEP1405 series platforms on top of each other. Do not place the external power supply on top of the VEP1405 series unit. Stacking the units or placing the power supply on top of a unit impairs cooling.

Power

Connect the platform to the applicable power source using the appropriate power cable. The VEP1405 series of systems ship with one external AC/DC power supply and one AC power cable.

When installing AC platforms, follow the requirements of the National Electrical Code ANSI/NFPA 70, where applicable.

The platform is powered-up when the power cable is connected between the platform and the power source.

⚠ CAUTION: Before servicing, ensure that the power cable is disconnected.

⚠ CAUTION: Use the power supply cable as the main disconnect device. Ensure that the socket-outlet is located near the equipment and is accessible.

Storing components

If you do not install the VEP1405 series unit and components immediately, properly store the platform and all optional components following these guidelines:

- The storage temperature range is from -40°C to 70°C (-40°F to 158°F) with humidity at 5% to 90% noncondensing
- Store on a dry surface or floor, away from direct sunlight, heat, and air conditioning ducts
- Store in a dust-free environment

i NOTE: ESD damage can occur when components are mishandled. Always wear an ESD-preventive wrist or heel ground strap when handling the platform and its accessories. After you remove the original packaging, place the VEP1405 series unit and its components on an antistatic surface.

VEP1405 Series Installation

To install the VEP1405 series unit, complete the installation procedures in the order that is presented in this section.

Always handle the platform and its components with care.

- i** **NOTE:** ESD damage can occur if components are mishandled. Always wear an ESD-preventive wrist or heel ground strap when handling the platform and its components. As with all electrical devices of this type, take all the necessary safety precautions to prevent injury when installing this platform.

Unpack

- i** **NOTE:** Before unpacking the platform, inspect the container and immediately report any evidence of damage.

When unpacking the VEP1405 series unit, ensure that the following items are included:

- One VEP1405 series system
 - Micro-USB console cable
 - One AC/DC power supply and AC power cable
 - Wall mount hardware
 - Dell EMC Networking Virtual Edge Platform (VEP) 1405 Getting Started Guide
 - Safety and Regulatory Information
 - Warranty and Support Information
1. Place the container on a clean, flat surface.
 2. Open the container.
 3. Carefully remove the unit from the container and place it on a secure and clean surface.
 4. Remove all packing material.
 5. Inspect the product and accessories for damage.

- i** **NOTE:** If damage to the product or accessories is found, contact your Dell EMC sales representative for assistance.

Platform power-up

Before you turn on the system, reinspect the rack mounting or desktop placement of platform, and verify that the power supply to the VEP1405 series unit is secure.

Verify the following:

- The ambient temperature around the unit, which may be higher than the room temperature, be within the limits that are specified for the VEP1405 series of systems, see [Specifications](#)
- There is sufficient clearance around the unit
- All protective covers are in place

- i** **NOTE:** If the components are mishandled, ESD damage can occur. Always wear an ESD-preventive wrist or heel ground strap when handling the platform and its components.

Power up sequence

The fans immediately come on at high speed when the platform powers up. The fan speed slows as the platform continues to boot.

Specifications

This section lists the specifications for the VEP1405 series of systems.

CAUTION: Operate the product at an ambient temperature between 0-40°C (32-104°F).

WARNING: There is a danger of explosion if the lithium battery is incorrectly replaced. Replace only with the same or equivalent type of battery. Dispose of the battery according to the manufacturer's instructions.

NOTE: For RoHS information, see <https://www.dell.com/learn/tw/zh/twcorp1/envt-info-materials>.

Chassis physical design

Table 2. Dell EMC Virtual Edge Platform (VEP) 1405 model descriptions

Model	CPU	Description
VEP1425	4-core	<ul style="list-style-type: none"> • 8 GB DDR4 • 16 GB eMMC • 120 GB SSD • 2x 2 Wi-Fi • 6x 1 GB Copper RJ45 • 2x 10 GB SFP+ • Versa software installed • Trusted Platform Module (TPM) 2.0 - World-wide except China • 2x USB 3.0 • Low-energy Bluetooth (BLE) • One fan
VEP1425N	4-core	<ul style="list-style-type: none"> • 8 GB DDR4 • 16 GB eMMC • 120 GB SSD • 6x 1 GB Copper RJ45 • 2x 10 GB SFP+ • Versa software installed • Trusted Platform Module (TPM) 2.0 - World-wide except China • 2x USB 3.0 • One fan
VEP1445	8-core	<ul style="list-style-type: none"> • 16 GB DDR4 • 16 GB eMMC • 240 GB SSD • 2x 2 Wi-Fi • 6x 1 GB Copper RJ45 • 2x 10 GB SFP+ • Versa software installed • Trusted Platform Module (TPM) 2.0 - World-wide except China • 2x USB 3.0 • Low-energy Bluetooth (BLE) • Two fans
VEP1445	8-core	<ul style="list-style-type: none"> • 32 GB DDR4

Table 2. Dell EMC Virtual Edge Platform (VEP) 1405 model descriptions (continued)

Model	CPU	Description
		<ul style="list-style-type: none"> ● 16 GB eMMC ● 960 GB SSD ● 2x 2 Wi-Fi ● 6x 1 GB Copper RJ45 ● 2x 10 GB SFP+ ● ADVA software installed ● Trusted Platform Module (TPM) 2.0 - World-wide except China ● 2x USB 3.0 ● Low-energy Bluetooth (BLE) ● Two fans
VEP1445N	8-core	<ul style="list-style-type: none"> ● 16 GB DDR4 ● 16 GB eMMC ● 240 GB SSD ● 6x 1 GB Copper RJ45 ● 2x 10 GB SFP+ ● Versa software installed ● Trusted Platform Module (TPM) 2.0 - World-wide except China ● 2x USB 3.0 ● Two fans
VEP1485	16-core	<ul style="list-style-type: none"> ● 32 GB DDR4 ● 16 GB eMMC ● 240 G SSD ● 2x 2 Wi-Fi ● 6x 1 GB Copper RJ45 ● 2x 10 GB SFP+ ● Versa software installed ● Trusted Platform Module (TPM) 2.0 - World-wide except China ● 2x USB 3.0 ● Low-energy Bluetooth (BLE) ● Two fans
VEP1485	16-core	<ul style="list-style-type: none"> ● 64 GB DDR4 ● 16 GB eMMC ● 2 TB SSD ● 2x 2 Wi-Fi ● 6x 1 GB Copper RJ45 ● 2x 10 GB SFP+ ● ADVA software installed ● Trusted Platform Module (TPM) 2.0 - World-wide except China ● 2x USB 3.0 ● Low-energy Bluetooth (BLE) ● Two fans
VEP1485N	16-core	<ul style="list-style-type: none"> ● 32 GB DDR4 ● 16 GB eMMC ● 240 G SSD ● 6x 1 GB Copper RJ45 ● 2x 10 GB SFP+ ● Versa software installed ● Trusted Platform Module (TPM) 2.0 - World-wide except China ● 2x USB 3.0 ● Two fans

NOTE: For a listing of the supported optics guidelines for the VEP1405 series, see the [Virtual Edge Platform 1405 Series Technology Guide](#).



Figure 9. VEP1405 series front view

1. Security lock port
2. USB port

NOTE: An additional USB port is located on the opposite side of the system.

3. System status indicator LED

Table 3. Front view system status indicator LED

Color	Status
Red	Power on
White	System is booting
Green	Operating system boots with diagOS
Blue	Reset button is pressed for more than five seconds NOTE: See the Reset button behavior table below for more information.

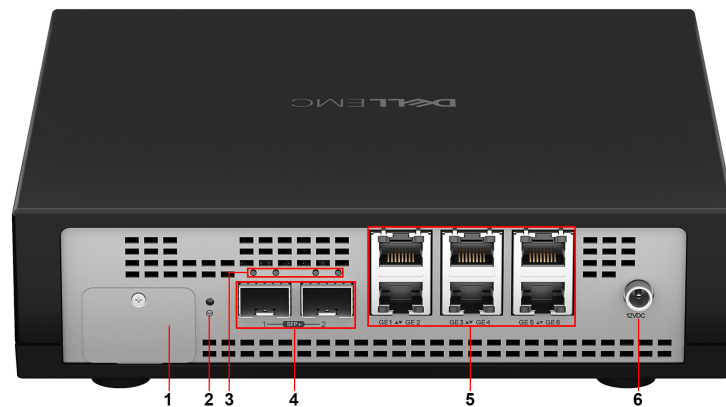

Figure 10. VEP1405 series rear view (with port cover)

1. Port cover
2. Reset button

NOTE: After upgrading to UFW 2.2, the system response when you push the Reset button on a running VEP14xx switch is determined by the operating system that the switch is currently running.

NOTE: See the [Reset button behavior](#) table below for more information.

3. LED status indicators for SFP+ ports
4. SFP+ ports
5. Ethernet ports and LED status indicators
6. Power connection port

NOTE: To prevent the VEP1405 series system console port from being accessed in a nonsecure location, the system ships from the factory with a plate covering the micro USB port. To uncover the port, use a #0 (2.5 mm) Phillips head screwdriver to loosen or remove the screw that holds the plate in place.

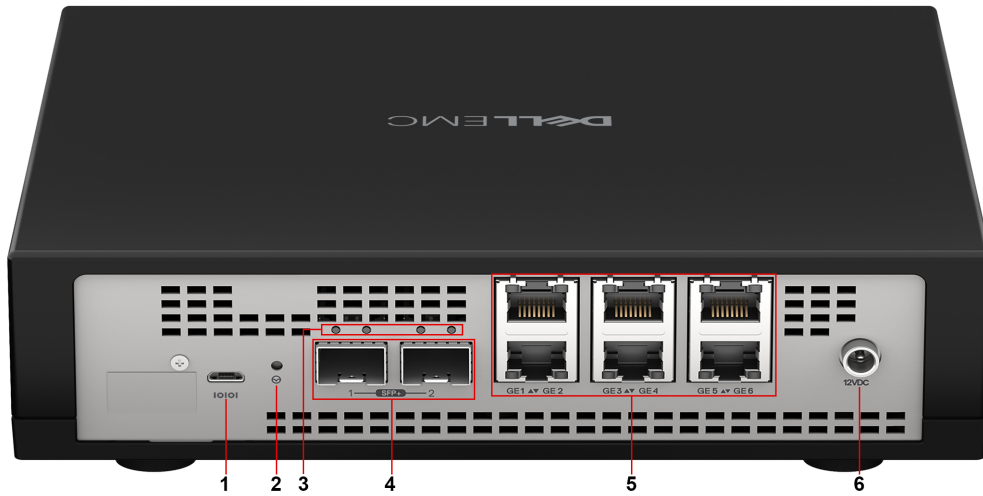

Figure 11. VEP1405 series back view (without port cover)

1. Micro USB serial console port
2. Reset button

NOTE: After upgrading to UFW 2.2, the system response when you push the Reset button on a running VEP14xx switch is determined by the operating system that the switch is currently running.

NOTE: See the [Reset button behavior](#) table below for more information.

3. LED status indicators for SFP+ ports
4. SFP+ ports
5. Ethernet ports and LED status indicators
6. Power connection port

Table 4. Back view system status indicator LED behavior

Class	Behavior
1000 Base-T LED	<ul style="list-style-type: none"> ● Link LED - Green or amber <ul style="list-style-type: none"> ○ Solid green - Port is linked and running at maximum 1000M speed on ethernet port ○ Solid amber - Port is linked and running at lower 100M or 10M speed on ethernet port ○ Off - No link ● Activity LED - Green <p>NOTE: The LED flashes green during port activity.</p> <ul style="list-style-type: none"> ○ Off - no port activity
SFP+ LED	<ul style="list-style-type: none"> ● Link LED - Green or amber <ul style="list-style-type: none"> ○ Solid green - Port is linked and running at 10G speed ○ Solid amber - Port is linked and running at 1G speed ○ Off - No link ● Activity LED - Green <p>NOTE: The LED flashes green during port activity.</p> <ul style="list-style-type: none"> ○ Off - no port activity

Table 5. Reset button behavior

Action	Behavior
Press the Reset button. When the system is powered off:	System powers on
Press the Reset button for more than 5 seconds: <i>i</i> NOTE: When the system is already powered on, the system responds as described in the Behavior column.	<ul style="list-style-type: none"> • System reboots • Status indicator LED color changes to blue • Flag indicating a long push is set by the BIOS in the CMOS RAM • Flag allows user to have the operating system detect a long button push <i>i</i> NOTE: After upgrading to UFW 2.2, the system response when you push the Reset button on a running VEP14xx switch is determined by the operating system that the switch is currently running.

Table 6. Chassis physical design

Parameter	Configuration option 1	Configuration option 2
Height	5.2 cm (2.0 in)	5.2 cm (2.0 in)
Width	20.8 cm (8.1 in)	20.8 cm (8.1 in)
Depth	20.0 cm (7.9 in)	20.0 cm (7.9 in)
Chassis weight with factory-installed components	<ul style="list-style-type: none"> • 4-core: 1.44 kg (3.17 lb) • 8-core: 1.42 kg (3.13 lb) • 16-core: 1.44 kg (3.17 lb) 	<ul style="list-style-type: none"> • 8-core: 1.42 kg (3.13 lb) • 16-core: 1.44 kg (3.17 lb)

i **NOTE:** Chassis weight does not include the weight of the power supply.

Table 7. Environmental parameters

Parameter	Configuration option 1	Configuration option 2
Operating temperature	0–40°C (32°F–104°F) continuously	0–40°C (32°F–104°F) continuously
Operating humidity	<ul style="list-style-type: none"> • 5% to 85% (RH), noncondensing continuously • 5% to 90% (RH), noncondensing short-term (< 1% of operational hour per year) 	<ul style="list-style-type: none"> • 5% to 85% (RH), noncondensing continuously • 5% to 90% (RH), noncondensing short-term (< 1% of operational hour per year)
Storage temperature	–40°–70°C (–40° to 158°F)	–40°–70°C (–40° to 158°F)
Storage humidity	5% to 90% (RH), noncondensing	5% to 90% (RH), noncondensing
Maximum operational altitude	3,048 meters (10,000 ft) with no performance degradation to 950 meters (3117 ft)	3,048 meters (10,000 ft) with no performance degradation to 950 meters (3117 ft)
Maximum nonoperational altitude	10,668 meters (35,000 ft)	10,668 meters (35,000 ft)

Table 8. AC power requirements

Parameter	Configuration option 1	Configuration option 2
Power supply	100–240 VAC 50/60 Hz	100–240 VAC 50/60 Hz
Maximum current draw per system - AC	<ul style="list-style-type: none"> • 100 VAC: 2.0A • 240 VAC: 1.0A 	<ul style="list-style-type: none"> • 100 VAC: 2.0A • 240 VAC: 1.0A
Power consumption	Typical: <ul style="list-style-type: none"> • 40 W (16 core) • 35 W (8 core) 	Typical: <ul style="list-style-type: none"> • 40 W (16 core) • 35 W (8 core)

Table 8. AC power requirements (continued)

Parameter	Configuration option 1	Configuration option 2
	<ul style="list-style-type: none"> • 20 W (4 core) Maximum: <ul style="list-style-type: none"> • 50 W (16 core) • 45 W (8 core) • 30 W (4 core) 	Maximum: <ul style="list-style-type: none"> • 50 W (16 core) • 45 W (8 core)

NOTE: For the most current AC power requirements and power consumption specifications, see the Installation Guide at <https://www.dell.com/support>.

Safety standards and compliance agency certifications

- CUS UL 60950-1, 2nd Edition
 - Meets or exceeds Hi Pot and Ground Continuity testing per UL 60950-1.
- CSA 60950-1-03, 2nd Edition
- EN 60950-1, 2nd Edition
- EN 60825-1, 1st Edition
- EN 60825-1 Safety of Laser Products—Part 1: Equipment Classification Requirements and User’s Guide
- EN 60825-2 Safety of Laser Products—Part 2: Safety of Optical Fibre Communication Systems
- FDA Regulation 21CFR 1040.10 and 1040.11
- IEC 60950-1, 2nd Ed, including all National Deviations and Group Differences
- IEC 62368-1

Product recycling and disposal

You must recycle or discard this switch according to applicable local and national regulations. Dell EMC encourages owners of information technology (IT) equipment to responsibly recycle their equipment when it is no longer needed. Dell EMC offers a variety of product return programs and services in several countries to assist equipment owners in recycling their IT products.

Waste electrical and electronic equipment (WEEE) directive for recovery, recycle and reuse of IT and telecommunications products

Dell EMC switches are labeled in accordance with European Directive 2002/96/EC concerning waste electrical and electronic equipment (WEEE). The Directive determines the framework for the return and recycling of used appliances as applicable throughout the European Union. This label is applied to various products to indicate that the product is not to be thrown away, but rather reclaimed upon end of life per this Directive.



Figure 12. The European WEEE symbol

In accordance with the European WEEE Directive, electrical and electronic equipment (EEE) is to be collected separately and to be reused, recycled, or recovered at end of life. Users of EEE with the WEEE marking per Annex IV of the WEEE Directive, as shown above, must not dispose of end of life EEE as unsorted municipal waste, but use the collection framework available to customers for the return, recycling and recovery of WEEE. Customer participation is important to minimize any potential effects of EEE on the environment and human health due to the potential presence of hazardous substances in EEE.

Dell EMC products, which fall within the scope of the WEEE, are labeled with the crossed-out wheelie-bin symbol, as shown above, as required by WEEE.

For information on Dell EMC product recycling offerings, see the WEEE Recycling instructions on Support. For more information, contact the Dell EMC Technical Assistance Center.

Agency compliance

The VEP1405 is designed to comply with the following safety and agency requirements:

India

This product conforms to the relevant Essential Requirements of TEC, Department of Telecommunications, Ministry of Communications, Govt of India, New Delhi-110001.

USA Federal Communications Commission statement

 **CAUTION: The use of external signal amplifiers in-line with the transceiver antennas is strictly prohibited.**

 **NOTE:** Some of the following declarations may apply only to systems that contain wireless capabilities

This device complies with Part 15 of the FCC Rules. Operation is subject to the following two conditions:

1) This device may not cause harmful interference, and (2) this device must accept any interference received, including interference that may cause undesired operation.

This equipment has been tested and found to comply with the limits for a Class A digital device, pursuant to Part 15 of the FCC Rules.

These limits are designed to provide reasonable protection against harmful interference in a residential installation. This equipment generates, uses and can radiate radio frequency energy and, if not installed and used in accordance with the instructions, may cause harmful interference to radio communications. However, there is no guarantee that interference will not occur in a particular installation. If this equipment does cause harmful interference to radio or television reception, which can be determined by turning the equipment off and on, the user is encouraged to try to correct the interference by one of the following measures.

Reorient or relocate the receiving antenna.

Increase the separation between the equipment and receiver.

Connect the equipment into an outlet on a circuit different from that to which the receiver is connected.

Consult the dealer or an experienced radio/TV technician for help.

FCC Caution:

Any changes or modifications not expressly approved by the party responsible for compliance could void the user's authority to operate this equipment.

This transmitter must not be co-located or operating in conjunction with any other antenna or transmitter.

Radiation Exposure Statement:

This equipment complies with FCC radiation exposure limits set forth for an uncontrolled environment. This equipment should be installed and operated with minimum distance 20cm between the radiator & your body.

 **NOTE:** The country code selection is for non-US model only and is not available to all US model. Per FCC regulation, all WiFi product marketed in US must fixed to US operation channels only.

Industry Canada Statement

This device complies with Industry Canada license-exempt RSS standards. Operation is subject to the following two conditions:

1. This device may not cause interference, and
2. This device must accept any interference, including interference that may cause undesired operation of the device.

Le présent appareil est conforme aux CNR d'Industrie Canada applicables aux appareils radio exempts de licence. L'exploitation est autorisée aux deux conditions suivantes:

1. l'appareil ne doit pas produire de brouillage, et
2. l'utilisateur de l'appareil doit accepter tout brouillage radioélectrique subi, même si le brouillage est susceptible d'en compromettre le fonctionnement.

This Class A digital apparatus complies with Canadian ICES-003.

Cet appareil numérique de la classe A est conforme à la norme NMB-003 du Canada.

This device complies with RSS-GEN, RSS-210, RSS-130, RSS-132, RSS-133, RSS-139, RSS-195, RSS-199 & RSS-247 of Industry Canada. Operation is subject to the condition that this device does not cause harmful interference.

Cet appareil est conforme à la norme RSS-GEN, RSS-210, RSS-130, RSS-132, RSS-133, RSS-139, RSS-195, RSS-199 & RSS-247 d'Industrie Canada. L'opération est soumise à la condition que cet appareil ne provoque aucune interférence nuisible.

This device and its antenna(s) must not be co-located or operating in conjunction with any other antenna or transmitter, except tested built-in radios.

Cet appareil et son antenne ne doivent pas être situés ou fonctionner en conjonction avec autre antenne ou un autre émetteur, exception faites des radios intégrées qui ont été testées.

The County Code Selection feature is disabled for products marketed in the US/Canada.

La fonction de sélection de l'indicatif du pays est désactivée pour les produits commercialisés aux États-Unis et au Canada.

Radiation Exposure Statement: This equipment complies with IC radiation exposure limits set forth for an uncontrolled environment. This equipment should be installed and operated with minimum distance 20cm between the radiator & your body.

Déclaration d'exposition aux radiations: Cet équipement est conforme aux limites d'exposition aux rayonnements IC établies pour un environnement non contrôlé. Cet équipement doit être installé et utilisé avec un minimum de 20 cm de distance entre la source de rayonnement et votre corps.

Caution:

1. The device for operation in the band 5150-5250 MHz is only for indoor use to reduce the potential for harmful interference to co-channel mobile satellite systems;
2. Users should also be advised that high-power radars are allocated as primary users (i.e. priority users) of the bands 5250-5350 MHz and 5650-5850 MHz and that these radars could cause interference and/or damage to LE-LAN devices.

Avertissement:

1. Les dispositifs fonctionnant dans la bande 5150-5250 MHz sont réservés uniquement pour une utilisation à l'intérieur afin de réduire les risques de brouillage préjudiciable aux systèmes de satellites mobiles utilisant les mêmes canaux;
2. De plus, les utilisateurs devraient aussi être avisés que les utilisateurs de radars de haute puissance sont désignés utilisateurs principaux (c.-à-d., qu'ils ont la priorité) pour les bandes 5250-5350 MHz et 5650-5850 MHz et que ces radars pourraient causer du brouillage et/ou des dommages aux dispositifs LAN-EL.

Radiocommunication equipment compliance for Thailand

The following is for radiocommunication equipment per act B.E. 2498:



Figure 13. Radiocommunication compliance certificate

Translation of content:
This radiocommunication equipment is exempted to possess license, user license, or radiocommunication station license as per NBTC notification regarding radiocommunication equipment and radiocommunication station has been exempted for license according to radio communication act B.E. 2498

Figure 14. Radiocommunication compliance certificate translation

Brasil – Aviso da Anatel

Este equipamento opera em caráter secundário, isto é, não tem direito a proteção contra interferência prejudicial, mesmo de estações do mesmo tipo, e não pode causar interferência a sistemas operando em caráter primário.



Figure 15. Brazil – Aviso da Anatel certificate

European Union EMC directive conformance statement

This product is in conformity with the protection requirements of EU Council Directive 2004/108/EC on the approximation of the laws of the Member States relating to electromagnetic compatibility. Dell EMC cannot accept responsibility for any failure to satisfy the protection requirements resulting from a non-recommended modification of this product, including the fitting of non-Dell EMC option cards.

This product has been tested and found to comply with the limits for Class A Information Technology Equipment according to CISPR 32/CISPR34 and EN55032 / EN55034. The limits for Class A equipment were derived for commercial and industrial environments to provide reasonable protection against interference with licensed communication equipment.

NOTE: This is a Class A product. In a domestic environment, this device may cause radio interference, in which case, you may be required to take adequate measures.

European Community Contact

Dell EMC, EMEA - Central

Dahlenweg 19

66265 Heusweiler

Germany

Tel: +49 172 6802630

Email: EMEA Central Sales

Japan VCCI compliance for Class A equipment

この装置は、情報処理装置等電波障害自主規制協議会 (VCCI) の基準に基づくクラス A 情報技術装置です。

この装置を家庭環境で使用すると電波妨害を引き起こすことがあります。

この場合には使用者が適切な対策を講ずるよう要求されることがあります。

This is Class A product based on the standard of the Voluntary Control Council For Interference by Information Technology Equipment (VCCI). If this equipment is used in a domestic environment, radio disturbance may arise. When such trouble occurs, the user may be required to take corrective actions.

⚠ WARNING: Use the AC power cables with Dell EMC equipment only. Do not use Dell EMC AC power cables with any unauthorized hardware.

本製品に同梱いたしております電源コードセットは、本製品専用です。

本電源コードセットは、本製品以外の製品ならびに他の用途でご使用いただくことは、出来ません。

製品本体には同梱され電源コードセットを使用し、他製品の電源コードセットを使用しないで下さい。

Wi-Fi and Bluetooth compliance certificate

電波法により 5GHz 帯は屋内使用に限ります。

BTE compliance certificate

タブレットコンピュータの使用目的オリエンテーション

使用者の体に対してタブレットコンピュータ画面側を抛抱き抱えるとは、タブレットの使用可能な方法ではありません。

WWAN トランスミッタがアクティブであるために、使用者の身体からタブレットコンピュータを 20 センテ上の距離を確保してください。

製品の他の 5 つの側面は、イル特徴としてタブレットの使用可能な向きを指定し使用者の者体に密着しながら使用することができます。

ありがとございます。

Korean certification of compliance

Korean certification of compliance

A 급 기기 (업무용방송통신기자재)	이 기기는 업무용 (A급) 전자파 적합기기로서 판매자 또는 사용자는 이 점을 주의하시기 바라며, 가정외의 지역에서 용하는 것을 목적으로 합니다.
------------------------	--

Korean package label

	[equipment type]
품명 (Product Name)	Ethernet switch
모델명 (Model)	[model number]
신청인 (Applicant)	Dell Technologies
제조사 (Manufacturer)	[Manufacturer]
제조년월 (Manufacturing Date)	[date]
제조국 (Country of Origin)	China

Radio compliance certificate

Korea (Korean warning statement is only required for devices contain 2400~2483 and/or 5725~5825 MHz radios). The following is the Korean radio compliance certification:

해당 무선설비는 운용 중 전파혼신 가능성이 있음

Mexico certification of compliance

La operación de este equipo está sujeta a las siguientes dos condiciones:

1. Es posible que este equipo o dispositivo no cause interferencia perjudicial y
2. Este equipo o dispositivo debe aceptar cualquier interferencia, incluyendo la que pueda causar su operación no deseada.

Taiwanese certification of compliance

The Taiwanese radio certification of compliance is as follows:

台灣: 國家通訊傳播委員會

低功率電波輻射性電機管理辦法

第十二條經型式認證合格之低功率射頻電機，非經許可，公司、商號或使用者均不得擅自變更頻率、加大功率或變更原設計之特性及功能。

第十四條低功率射頻電機之使用不得影響飛航安全及干擾合法通信；經發

現有干擾現象時，應立即停用，並改善至無干擾時方得繼續使用。前項合法通信，指依電信法規定作業之無線電通信。低功率射頻電機須忍受合法通信或工業、科學及醫療用電波輻射性電機設備之干擾。

在 5.25-5.35 兆赫頻帶內操作之無線資訊傳輸設備，限於室內使用。

Singapore certification of compliance

Singapore radio compliance.

Complies with IMDA Standards

Registration number: N2515-19

Support

The support site provides documents and tools to help you effectively use your equipment and mitigate network outages. Through the support site you can obtain technical information, access software upgrades and patches, download available management software, and manage your open cases. The support site provides integrated, secure access to these services.

To access the support site, go to <https://www.dell.com/support/>. To display information in your language, scroll down to the bottom of the web page and select your country from the drop-down menu.

- To obtain product-specific information, enter the 7-character service tag or 11-digit express service code of your platform and click the **Submit** button on the screen. To view the chassis service tag or express service code, locate the sticker underneath the system.
- To receive more technical support, click **Contact Us**. On the **Contact Information** web page, click **Technical Support**.

To access platform documentation, go to <https://www.dell.com/manuals/>.

To search for drivers and downloads, go to <https://www.dell.com/drivers/>.