

# Dell EMC DSS 9600 Servers

## Installation and Service Manual

## Notes, cautions, and warnings

 **NOTE:** A NOTE indicates important information that helps you make better use of your product.

 **CAUTION:** A CAUTION indicates either potential damage to hardware or loss of data and tells you how to avoid the problem.

 **WARNING:** A WARNING indicates a potential for property damage, personal injury, or death.

**Copyright © 2018 Dell Inc. or its subsidiaries. All rights reserved.** Dell, EMC, and other trademarks are trademarks of Dell Inc. or its subsidiaries. Other trademarks may be trademarks of their respective owners.

# Contents

<b>1 Overview</b>	<b>7</b>
System specifications	8
Front-panel features	9
Diagnostic indicators	9
NIC indicator codes	9
HDD Indicator codes	10
Locating your system service tag	11
<b>2 Documentation resources</b>	<b>12</b>
<b>3 Technical specifications</b>	<b>14</b>
Processor specifications	14
System battery specifications	14
Expansion bus specifications	14
Memory specifications	14
Ports and connector specifications	15
USB ports	15
NIC ports	15
DisplayPort	15
Environmental specifications	15
Temperature specifications	16
Relative humidity specifications	16
Maximum vibration specifications	16
Maximum shock specifications	16
Maximum altitude specifications	17
Operating temperature de-rating specifications	17
Particulate and gaseous contamination specifications	17
Standard operating temperature specifications	18
Expanded operating temperature specifications	18
Expanded operating temperature restrictions	19
<b>4 Initial system setup and configuration</b>	<b>20</b>
Setting up your system	20
iDRAC configuration	20
Options to set up iDRAC IP address	20
Log in to iDRAC	21
Options to install the operating system	21
Methods to download firmware and drivers	21
Downloading the drivers and firmware	22
<b>5 Pre-operating system management applications</b>	<b>23</b>
Options to manage the pre-operating system applications	23

System Setup.....	23
Viewing System Setup.....	23
System Setup details.....	24
System BIOS.....	24
iDRAC Settings utility.....	44
Dell Lifecycle Controller.....	45
Boot Manager.....	45
PXE boot.....	46
<b>6 Installing and removing server components.....</b>	<b>47</b>
Safety instructions.....	47
Before working inside your system.....	47
After working inside your system.....	47
Recommended tools.....	47
System memory.....	48
General memory module installation guidelines.....	48
Mode-specific guidelines.....	48
Memory optimized (independent channel) mode.....	49
Memory sparing.....	49
Memory mirroring.....	49
Sample memory configurations.....	51
Removing memory module.....	51
Installing memory module.....	52
Processor and heat sink.....	53
Removing heat sink.....	54
Removing processor.....	55
Installing processor.....	56
Installing heat sink.....	57
Expansion card and riser.....	60
Expansion card installation guidelines.....	60
Removing expansion card from slot 1.....	61
Installing expansion card into slot 1.....	61
Removing expansion card from slot 3.....	61
Installing expansion card into slot 3.....	62
Removing expansion card from slot 4.....	62
Installing expansion card into slot 4.....	62
Removing expansion card from slot 5.....	62
Installing expansion card into slot 5.....	63
Removing expansion card from slot 6.....	63
Installing expansion card into slot 6.....	63
System battery.....	63
Removing system battery.....	63
Installing system battery.....	64
Hard drive.....	65
Removing 2.5-inch hard drive from the rear bay.....	66
Installing 2.5-inch hard drive into the rear bay.....	67

Removing 3.5-inch hard drive from a tray.....	69
Installing 3.5-inch hard drive into a tray.....	73
Removing 2.5-inch hard drive from a tray.....	77
Installing 2.5-inch hard drive into a tray.....	81
Server board.....	85
Removing server board.....	85
Installing server board.....	88
Trusted platform module.....	91
Installing trusted platform module.....	92
Initializing TPM for BitLocker users.....	93
Initializing TPM for TXT users.....	93
Restoring the Service Tag by using the Easy Restore feature.....	94
Mini PERC battery.....	94
Removing Mini PERC battery.....	94
Installing Mini PERC battery.....	95
Supercaps.....	96
Removing Microsemi supercap.....	96
Installing Microsemi supercap.....	99
Removing Broadcom supercap.....	103
Installing Broadcom supercap.....	105
Mezzanine card and Mini PERC.....	108
Removing mezzanine card.....	108
Installing mezzanine card.....	111
Removing Mini PERC.....	114
Installing Mini PERC.....	118
M.2 SSD Module.....	122
Removing x8 PCIe M.2 card.....	122
Installing x8 PCIe M.2 card.....	126
Removing x8 SATA M.2 card.....	130
Installing x8 SATA M.2 card.....	134
Removing x16 PCIe M.2 card.....	138
Installing x16 PCIe M.2 card.....	141
Removing x16 SATA M.2 card.....	144
Installing x16 SATA M.2 card.....	147
PCIe card.....	150
Removing PCIe card.....	150
Installing PCIe card.....	153
OCP card.....	156
Removing OCP card from slot 1.....	156
Installing OCP card into slot 1.....	160
Removing OCP card from slot 3.....	164
Installing OCP card into slot 3.....	166
3M riser card.....	168
Removing 3M riser card.....	168
Installing 3M riser card.....	172

NPIO card.....	177
Removing NPIO card from the rear bay.....	177
Installing NPIO card in the rear bay.....	180
Node power distribution board(NPDB).....	184
Removing NPDB.....	184
Installing NPDB.....	185
Hard drive backplane.....	187
Removing HDD backplane.....	187
Installing HDD backplane.....	189
SAS expander board.....	191
Removing SAS expander board.....	191
Installing SAS expander board.....	192
Cable management arm.....	193
Removing CMA in the hard drive tray.....	193
Installing CMA in the hard drive tray.....	195
<b>7 Using system diagnostics.....</b>	<b>198</b>
Dell Embedded System Diagnostics.....	198
Running the Embedded System Diagnostics from Boot Manager.....	198
Running Embedded System Diagnostics from Lifecycle Controller.....	198
System diagnostic controls.....	199
<b>8 Jumpers and connectors.....</b>	<b>200</b>
<b>9 Troubleshooting your system.....</b>	<b>202</b>
Troubleshooting list.....	202
<b>10 Getting help.....</b>	<b>203</b>
Contacting Dell.....	203
Documentation feedback.....	203

# Overview

The DSS 9600 server contains a full-width chassis supporting the Intel® Xeon® Scalable platform. Each server supports up to two Intel® Xeon® Scalable processors.

**NOTE:** The product at time delivery may differ from the following illustrations.

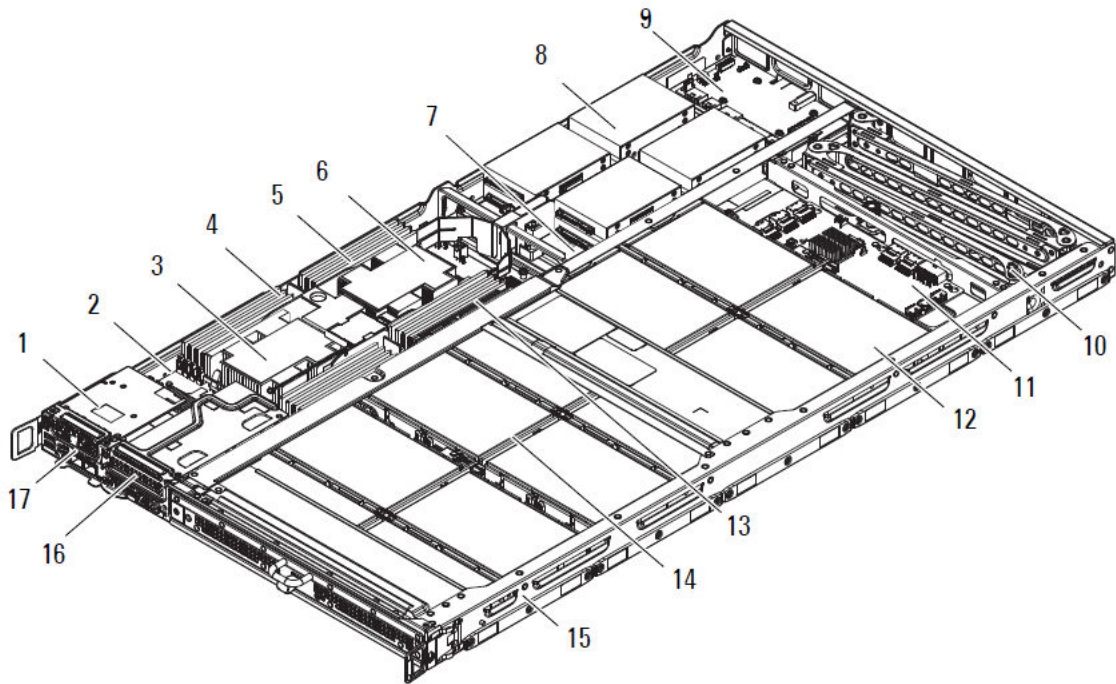

Figure 1. DSS 9600 server

Table 1. DSS 9600 features

No.	Item	Description
1	Expansion port, slot 1	Supports x8 mezzanine expansion cards, connected to CPU 1.
2	Server board	Server board (DSS 9600M) with DDR4 DIMM slots.
3	CPU heat sink 1	Heat sink for CPU 1.
4	CPU 1 DIMMs	Memory modules for CPU 1. For more information about memory modules, see System memory.
5	CPU 2 DIMMs	Memory modules for CPU 2. For more information about memory modules, see System memory.
6	CPU heat sink 2	Heat sink for CPU 2.

No.	Item	Description
7	Supercap	Supercap and holder for PCIe RAID card (Microsemi and Broadcom).
8	Server rear bay	Supports installation of up to eight 2.5-inch SSDs (SSD0—SSD7).
9	NPDB	Node power distribution board.
10	Cable management arm	Optimizes data and power cabling usage.
11	SAS expander board	Controller card which allows the expansion of storage capacity. External connections are supported through a SAS cable.
12	Hot swap HDD bay	Supports twelve 3.5-inch or 2.5-inch HDDs.
13	Expansion port, slot 5	Supports x16 PCIe expansion risers, directly connected to CPU 2.
14	HDD backplane	Supports four HDD modules, each server contains three HDD backplanes.
15	FW server chassis	Full width server chassis for DSS 9600 server.
16	Expansion port, slot 4	Supports x16 PCIe expansion risers, connected to CPU 1.
17	Expansion port, slot 3	Supports x8 OCP expansion cards, connected to CPU 1.

Topics:

- [System specifications](#)
- [Front-panel features](#)
- [Diagnostic indicators](#)
- [Locating your system service tag](#)

## System specifications

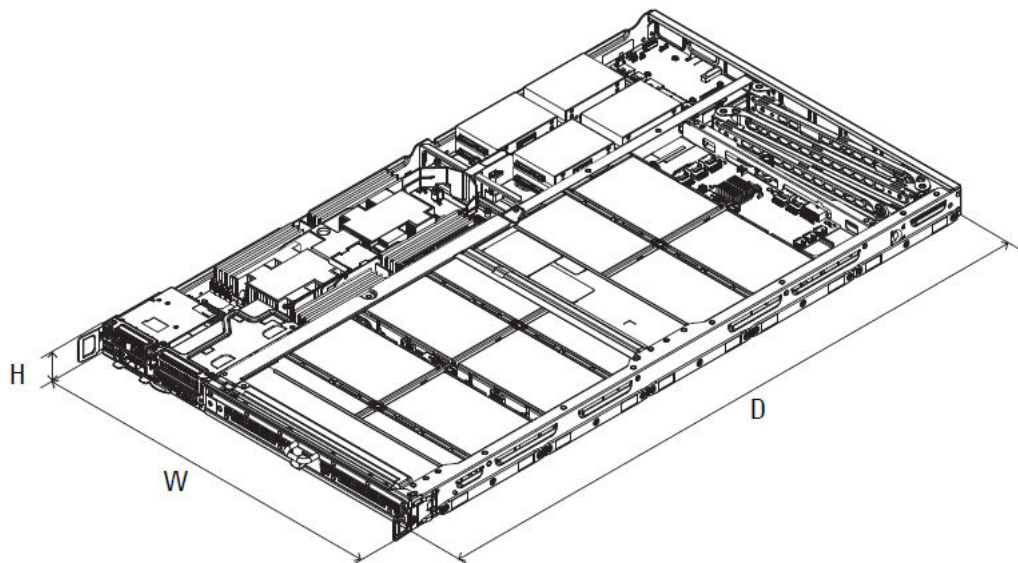
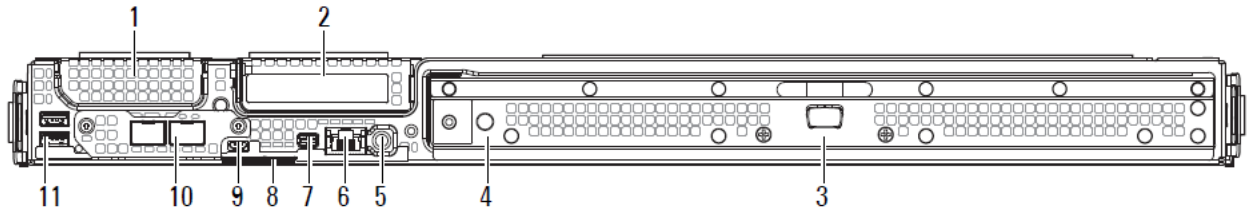

Figure 2. DSS 9600 dimensions

**Table 2. DSS 9600 dimensions**

Item	Description
Dimension (W x D x H)	527 mm x 930 mm x 47 mm (20.75 inch x 36.61 inch x 1.85 inch)
Weight (fully loaded)	26.06 kg (57.45 lb)

## Front-panel features



**Figure 3. Front-panel features**

**Table 3. Front-panel features**

No.	Item	Description
1	Expansion port, slot 1	Supports x8 mezzanine expansion cards. Connected to CPU 1.
2	Expansion port, slot 4	Supports x16 PCIe cards. Connected to CPU 1.
3	Hot swap HDD bay	Twelve x 3.5-inch or 2.5-inch hot swappable HDDs.
4	Global HDD LED	When lit, indicates an HDD fault.
5	Power button	Press the power button to turn the server on or off. The indicator on the button indicates if the system is on or off.
6	LAN port	Single 10/100/1000 Mbps RJ-45 connector shared between 1G LAN and iDRAC management LAN.
7	DisplayPort	Single mini DisplayPort connector.
8	Service tag	Location of information tag specifying the system Service Tag.
9	iDRAC Direct micro USB port	The iDRAC Direct micro USB port enables you to connect a portable device to the server.
10	Expansion port, slot 3	Supports OCP expansion cards. Connected to CPU 1.
11	USB port	Two USB 3.0 compliant ports.

## Diagnostic indicators

### NIC indicator codes

Each NIC on the back panel has an indicator that provides information about the network activity and link status. The activity LED indicates whether data is flowing through NIC or not. The link LED indicates the speed of the connected network.

**Table 4. NIC indicators**

Convention	Status	Condition
A	Link and activity indicators are off	The NIC is not connected to the network.
B	Link indicator is green and activity indicator is blinking green	The NIC is connected to a valid network at its maximum port speed and data is being sent or received.
C	Link indicator is amber and activity indicator is blinking green	The NIC is connected to a valid network at less than its maximum port speed and data is being sent or received.
D	Link indicator is green and activity indicator is off	The NIC is connected to a valid network at its maximum port speed and data is not being sent or received.
E	Link indicator is amber and activity indicator is off	The NIC is connected to a valid network at less than its maximum port speed and data is not being sent or received.
F	Link indicator is blinking green and activity is off	NIC identify is enabled through the NIC configuration utility.

## HDD Indicator codes

The expansion adapter has LED headers that correspond to access activity and link status.

PERC H330 Mini Mono, PERC H730P Mini Mono, PERC H730, Broadcom 9361-8i and Broadcom 9380-4i4e

**Table 5. PERC H330 Mini Mono, PERC H730P Mini Mono, PERC H730, Broadcom 9361-8i and Broadcom 9380-4i4e**

LED state	HDD state	Green LED	Amber LED
1	Empty	Off	Off
2	Online	On	Off
3	Identify/Prepare for removal	Blinking	Off
4	Rebuild	Blinking	Off
5	Fault	Off	Blinking

Broadcom 9300-4i4e

**Table 6. Broadcom 9300-4i4e**

LED state	HDD state	Green LED	Amber LED
1	Empty	Off	Off
2	Online	On	Off
3	Identify/Prepare for removal	Blinking	Off
4	Rebuild	NA	NA
5	Fault	On	Off

## Locating your system service tag

Your system is identified by a unique Express Service Code and Service Tag number. The Express Service Code and Service Tag are found on the front of the system by pulling out the information tag. Alternatively, the information may be on a sticker on the chassis of the system. This information is used by Dell to route support calls to the appropriate personnel.

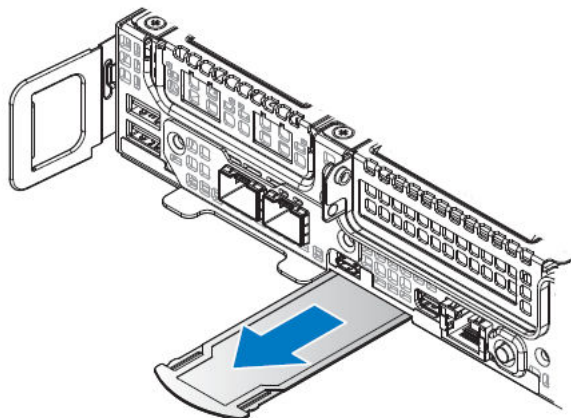

**Figure 4. Service Tag location**

## Documentation resources

This section provides information about the documentation resources for your system.

**Table 7. Additional documentation resources for your system**

Task	Document	Location
Setting up your system	For information about installing the system into a rack, see the Rack documentation included with your rack solution.	<a href="http://Dell.com/dssmanuals">http://Dell.com/dssmanuals</a>
	For information about turning on the system and the technical specifications of your system, see the Getting Started With Your System document that is shipped with your system.	<a href="http://Dell.com/dssmanuals">http://Dell.com/dssmanuals</a>
Configuring your system	For information about the iDRAC features, configuring and logging in to iDRAC, and managing your system remotely, see the Integrated Dell Remote Access Controller User's Guide.	<a href="http://Dell.com/idracmanuals">http://Dell.com/idracmanuals</a>
	For information about installing the operating system, see the operating system documentation.	<a href="http://Dell.com/operatingsystemmanuals">http://Dell.com/operatingsystemmanuals</a>
	For information about understanding Remote Access Controller Admin (RACADM) subcommands and supported RACADM interfaces, see the RACADM Command Line Reference Guide for iDRAC.	<a href="http://Dell.com/idracmanuals">http://Dell.com/idracmanuals</a>
	For information about updating drivers and firmware, see the Methods to download firmware and drivers section in this document.	<a href="http://Dell.com/support/drivers">http://Dell.com/support/drivers</a>
Managing your system	For information about systems management software offered by Dell, see the Dell OpenManage Systems Management Overview Guide.	<a href="http://Dell.com/openmanagemanuals">http://Dell.com/openmanagemanuals</a>
	For information about setting up, using, and troubleshooting OpenManage, see the Dell OpenManage Server Administrator User's Guide.	<a href="http://Dell.com/openmanagemanuals">http://Dell.com/openmanagemanuals</a>
	For information about installing, using, and troubleshooting Dell OpenManage Essentials, see the Dell OpenManage Essentials User's Guide.	<a href="http://Dell.com/openmanagemanuals">http://Dell.com/openmanagemanuals</a>
	For information about installing and using Dell SupportAssist, see the Dell EMC SupportAssist Enterprise User's Guide.	Dell.com/SupportAssist Enterprise
	For information about installing and using Active System Manager (ASM), see the Active System Manager User's Guide.	<a href="http://Dell.com/asmdocs">http://Dell.com/asmdocs</a>
	For understanding the features of Dell Lifecycle Controller (LCC), see the Dell Lifecycle Controller User's Guide.	<a href="http://Dell.com/idracmanuals">http://Dell.com/idracmanuals</a>

Task	Document	Location
	For information about partner programs enterprise systems management, see the OpenManage Connections Enterprise Systems Management documents.	<a href="http://Dell.com/omconnectionsenterprisesystemsmangement">http://Dell.com/omconnectionsenterprisesystemsmangement</a>
	For information about connections and client systems management, see the OpenManage Connections Client Systems Management documentation.	<a href="http://Dell.com/dellclientcommandsuitemanuals">http://Dell.com/dellclientcommandsuitemanuals</a>
	For information about viewing inventory, performing configuration and monitoring tasks, remotely turning on or off servers, and enabling alerts for events on servers and components using the Dell Chassis Management Controller (CMC), see the CMC User's Guide.	<a href="http://Dell.com/esmmanuals">http://Dell.com/esmmanuals</a>
Understanding event and error messages	For information about checking the event and error messages generated by the system firmware and agents that monitor system components, see the Dell Event and Error Messages Reference Guide.	<a href="http://Dell.com/openmanagemanuals">http://Dell.com/openmanagemanuals</a> > OpenManage software

# Technical specifications

The technical and environmental specifications of your system are outlined in this section.

Topics:

- [Processor specifications](#)
- [System battery specifications](#)
- [Expansion bus specifications](#)
- [Memory specifications](#)
- [Ports and connector specifications](#)
- [Environmental specifications](#)

## Processor specifications

The system is based on the Intel Xeon Processor Scalable Family and offers dual processor sockets.

## System battery specifications

The system supports a CR 2032 3.0-V lithium coin cell system battery.

## Expansion bus specifications

The system supports PCI express (PCIe) generation 3 expansion cards, which need to be installed on the server board using expansion card risers. The following is a list of supported expansion card risers.

**Table 8. Expansion bus specification**

PCIe slots	Description	Form factor
1	Dell mezzanine slot	x8
2	OCP	x8
3	OCP	x8
4	Main PCIe slot	x16 (PCIe low profile)
5	2nd PCIe slot	x16 (PCIe low profile)
6	4 x NVMe slot	x16

## Memory specifications

The system supports DDR4 registered DIMMs (RDIMMs) and Load Reduced DIMMs (LRDIMMs).

**NOTE:**  
Maximum memory is processor dependent.

**Table 9. Memory specifications**

Memory module sockets	Memory type	Memory capacity	Minimum RAM	Maximum RAM
Sixteen DIMM sockets	RDIMM	512 GB	32 GB with dual processors (minimum one memory module per processor)	512 GB
	LRDIMM	2048 GB	64 GB with dual processors (minimum one memory module per processor)	1024 GB

**NOTE:** Maximum available RAM is dependent on CPU SKU type.

## Ports and connector specifications

### USB ports

The system supports the following:

- USB 3.0-compliant ports internally and on the front panel

The following table provides more information about the USB specifications:

**Table 10. USB specifications**

Internal	Front panel
Two 4-pin, USB 3.0-compliant port	<ul style="list-style-type: none"> <li>• Two 4-pin, USB 3.0-compliant port</li> <li>• Micro-AB USB connector</li> </ul>

### NIC ports

The systems supports one embedded Network Interface Controller (NIC) port.

### DisplayPort

The system supports one mini DisplayPort connector.

## Environmental specifications

**NOTE:** For additional information about environmental measurements for specific system configurations, see [http://Dell.com/environmental\\_datasheets](http://Dell.com/environmental_datasheets).

# Temperature specifications

Table 11. Temperature specifications

Temperature	Specifications
Storage	-40°C to 65°C (-40°F to 149°F)
Continuous operation (altitudes under 950 m / 3,117 ft)	10°C to 35°C (50°F to 95°F), avoiding direct sunlight
Fresh air	For information about fresh air, see Expanded Operating Temperature section.
Maximum temperature gradient (operation and storage)	20°C/h (36°F/h)

# Relative humidity specifications

Table 12. Relative humidity specifications

Relative humidity	Specifications
Storage	5% to 95% RH with 33°C (91°F) maximum dew point. Atmosphere must be non-condensing at all times.
Operating	10% to 80% relative humidity with 29°C (84.2°)

# Maximum vibration specifications

Table 13. Maximum vibration specifications

Maximum vibration	Specifications
Operating	0.26 Grms at 5 Hz to 350 Hz (all operational orientations)
Storage	1.88 Grms at 10 Hz to 500 Hz for 15 min (all six sides tested)

# Maximum shock specifications

Table 14. Maximum shock specifications

Maximum shock	Specifications
Operating	24 executed shock pulses 6 G in the positive and negative x, y, z axis up to 11 ms (four pulses on each side of the system)
Storage	Six consecutively executed shock pulses of 71 G in the positive and negative x, y, z axes up to 2 ms (one pulse on each side of the system)

# Maximum altitude specifications

**Table 15. Maximum altitude specifications**

Maximum altitude	Specifications
Operating	3,048 m (10,000 ft)
Storage	12,000 m (39,370 ft)

# Operating temperature de-rating specifications

**Table 16. Operating temperature de-rating specifications**

Operating temperature de-rating	Specifications
Up to 35°C (95°F)	Maximum temperature is reduced by 1°C/300 m (1°F/547 ft) above 950 m (3,117 ft).
35°C to 40°C (95°F to 104°F)	Maximum temperature is reduced by 1°C/175 m (1°F/319 ft) above 950 m (3,117 ft).
40°C to 45°C (104°F to 113°F)	Maximum temperature is reduced by 1°C/125 m (1°F/228 ft) above 950 m (3,117 ft).

# Particulate and gaseous contamination specifications

The following table defines the limitations that help avoid any equipment damage or failure from particulates and gaseous contamination. If the levels of particulates or gaseous pollution exceed the specified limitations and result in equipment damage or failure, you may need to rectify the environmental conditions. Re-mediation of environmental conditions is the responsibility of the customer.

**Table 17. Particulate contamination specifications**

Particulate contamination	Specifications
Air filtration	<p>Data center air filtration as defined by ISO Class 8 per ISO 14644-1 with a 95% upper confidence limit.</p> <p><b>i</b>   <b>NOTE: This condition applies to data center environments only. Air filtration requirements do not apply to IT equipment designed to be used outside a data center, in environments such as an office or factory floor.</b></p> <p><b>i</b>   <b>NOTE: Air entering the data center must have MERV11 or MERV13 filtration.</b></p>
Conductive dust	<p>Air must be free of conductive dust, zinc whiskers, or other conductive particles.</p> <p><b>i</b>   <b>NOTE: This condition applies to data center and non-data center environments.</b></p>
Corrosive dust	<ul style="list-style-type: none"> <li>Air must be free of corrosive dust.</li> </ul>

Particulate contamination	Specifications
	<ul style="list-style-type: none"> <li>Residual dust present in the air must have a deliquescent point less than 60% relative humidity.</li> </ul> <p><b>NOTE:</b> This condition applies to data center and non-data center environments.</p>

**Table 18. Gaseous contamination specifications**

Gaseous contamination	Specifications
Copper coupon corrosion rate	<300 Å/month per Class G1 as defined by ANSI/ISA71.04-1985
Silver coupon corrosion rate	<200 Å/month as defined by AHSRAE TC9.9

**NOTE:** Maximum corrosive contaminant levels measured at ≤50% relative humidity.

## Standard operating temperature specifications

**Table 19. Standard operating temperature specifications**

Standard operating temperature	Specifications
Continuous operation (altitudes under 950 m / 3,117 ft)	10°C to 35°C (50°F to 95°F), avoiding direct sunlight

**NOTE:** The system supports a maximum 165 W TDP.

## Expanded operating temperature specifications

**Table 20. Expanded operating temperature specifications**

Expanded operating temperature	Specifications
≤10% of annual operating hours	<p>5°C to 40°C (41°F to 104°F), avoiding direct sunlight on the equipment</p> <p><b>NOTE:</b> Outside the standard operating temperature (10°C to 35°C / 50°F to 95°F), the system can operate for a maximum of 10% of its annual operating hours in temperatures as low as 5°C (41°F) and as high as 40°C (104°F).</p> <p>For temperatures between 35°C and 40°C (95°F and 104°F), de-rate maximum allowable temperature by 1°C per 175 m above 950 m (1°F per 319 ft).</p>
≤1% of annual operating hours	<p>–5°C to 45°C (23°F to 113°F) at 5% to 90% RH with 29°C (84°F) dew point</p> <p><b>NOTE:</b> Outside the standard operating temperature (10°C to 35°C / 50°F to 95°F), the system can operate down to –5°C (23°F) or up to 45°C (113°F) for a maximum of 1% of its annual operating hours.</p> <p>For temperatures between 40°C and 45°C (104°F and 113°F), de-rate maximum allowable temperature by 1°C per 125 m above 950 m (1°F per 228 ft).</p>

ⓘ | **NOTE:** When operating in the expanded temperature range, system performance may be impacted.

ⓘ | **NOTE:** When operating in the expanded temperature range, ambient temperature warnings may be reported on the LCD panel and in the System Event Log.

## Expanded operating temperature restrictions

- Do not perform a cold startup below 5°C (41°F).
- The specified operating temperature is based on a maximum altitude of 950 m (3,116 ft).
- PCIe Cards are not supported on slots 1, 2 and 3.
- A maximum of six hard drives are supported on half width systems with a 165 W processor.
- Redundant power supplies are required.
- Non-Dell qualified peripheral cards and/or peripheral cards greater than 25 W are not supported.

# Initial system setup and configuration

## Setting up your system

Complete the following steps to set up your system:

- 1 Unpack the system.
- 2 Install the system into the rack.
- 3 Connect the peripherals to the system.
- 4 Connect the system to its electrical outlet.
- 5 Turn the system on by pressing the power button or by using iDRAC.
- 6 Turn on the attached peripherals.

For more information about setting up your system, see your Getting Started Guide shipped with your system.

## iDRAC configuration

The Integrated Dell Remote Access Controller (iDRAC) is designed to make system administrators more productive and improve the overall availability of Dell systems. iDRAC alerts administrators to system issues, helps them perform remote system management, and reduces the need for physical access to the system.

## Options to set up iDRAC IP address

You must configure the initial network settings based on your network infrastructure to enable the communication to and from iDRAC.

You must use the default iDRAC IP address **192.168.0.120** to configure the initial network settings, including setting up DHCP or a static IP for iDRAC. You can set up the IP address by using one of the following interfaces:

**Table 21. Options to set up iDRAC IP address**

Interfaces	Document/Section
iDRAC Settings utility	See Dell Integrated Dell Remote Access Controller User's Guide at <a href="http://Dell.com/idracmanuals">http://Dell.com/idracmanuals</a>
Dell Deployment Toolkit	See Dell Deployment Toolkit User's Guide at <a href="http://Dell.com/openmanagemanuals">http://Dell.com/openmanagemanuals</a>
Remote Access Controller Admin (RACADM)	See RACADM Command Line Interface Reference Guide and Integrated Dell Remote Access Controller User's Guide at <a href="http://Dell.com/idracmanuals">http://Dell.com/idracmanuals</a>
Remote Services that include Web Services Management (WS-Man)	See Dell Integrated Dell Remote Access Controller User's Guide at <a href="http://Dell.com/idracmanuals">http://Dell.com/idracmanuals</a>
Dell Lifecycle Controller	See Dell Lifecycle Controller User's Guide at <a href="http://Dell.com/idracmanuals">http://Dell.com/idracmanuals</a>

**NOTE:** To access iDRAC, ensure that you connect the network cable to the Ethernet port in shared mode or the iDRAC Management port on the server board.

- ① **NOTE:** To access iDRAC connect the network cable to the Ethernet connector on the server board.
- ① **NOTE:** To access iDRAC, ensure that you install the iDRAC port card or connect the network cable to the Ethernet connector 1 on the server board.
- ① **NOTE:** To access BMC, ensure that you install the remote management port card or connect the network cable to the Ethernet connector 1 on the server board.

## Log in to iDRAC

You can log in to iDRAC as:

- iDRAC user
- Microsoft Active Directory user
- Lightweight Directory Access Protocol (LDAP) user

If you have opted for secure default access to iDRAC, the system Information tag contains the iDRAC secure default password. If you have not opted for secure default access to iDRAC, then the default user name and password are `root` and `calvin`. You can also log in by using Single Sign-On or Smart Card.

- ① **NOTE:** You must have iDRAC credentials to log in to iDRAC.
- ① **NOTE:** Ensure that you change the default user name and password after setting up the iDRAC IP address.

For more information about logging in to iDRAC and iDRAC licenses, see the latest Integrated Dell Remote Access Controller User's Guide at <http://Dell.com/idracmanuals>.

You can also access iDRAC by using RACADM. For more information, see the RACADM Command Line Interface Reference Guide and the Integrated Dell Remote Access Controller User's Guide at <http://Dell.com/idracmanuals>.

## Options to install the operating system

If the system is shipped without an operating system, install the supported operating system by using one of the following resources:

**Table 22. Resources to install the operating system**

Resources	Location
Dell Systems Management Tools and Documentation media	<a href="http://Dell.com/operatingsystemmanuals">http://Dell.com/operatingsystemmanuals</a>
Dell Lifecycle Controller	<a href="http://Dell.com/idracmanuals">http://Dell.com/idracmanuals</a>
Dell OpenManage Deployment Toolkit	<a href="http://Dell.com/openmanagemanuals">http://Dell.com/openmanagemanuals</a>
Dell certified VMware ESXi	<a href="http://Dell.com/virtualizationsolutions">http://Dell.com/virtualizationsolutions</a>
Installation and How-to videos for supported operating systems on Dell PowerEdge systems	Supported Operating Systems for Dell PowerEdge Systems

## Methods to download firmware and drivers

You can download the firmware and drivers by using any of the following methods:

**Table 23. Firmware and drivers**

Methods	Location
From the Dell Support site	<a href="http://Dell.com/support/home">http://Dell.com/support/home</a>
Using Dell Remote Access Controller Lifecycle Controller (iDRAC with LC)	<a href="http://Dell.com/idracmanuals">http://Dell.com/idracmanuals</a>
Using BMC	<a href="http://Dell.com/idracmanuals">http://Dell.com/idracmanuals</a>
Using Dell Repository Manager (DRM)	<a href="http://Dell.com/openmanagemanuals">http://Dell.com/openmanagemanuals</a>
Using Dell Server Update Utility (SUU)	<a href="http://Dell.com/openmanagemanuals">http://Dell.com/openmanagemanuals</a>
Using Dell OpenManage Deployment Toolkit (DTK)	<a href="http://Dell.com/openmanagemanuals">http://Dell.com/openmanagemanuals</a>

You can download the firmware and drivers from the Dell support site at <http://Dell.com/support/home>.

## Downloading the drivers and firmware

Ensure that you clear the web browser cache before downloading the drivers and firmware.

Dell recommends that you download and install the latest BIOS, drivers, and systems management firmware on your system which is listed in Dell Hyperconverged Infrastructure with Microsoft Software Defined Stack Support Matrix.

- 1 Go to <http://Dell.com/support/drivers>.
- 2 In the Drivers & Downloads section, type the Service Tag of your system in the **Service Tag or Express Service Code** box, and then click **Submit**.  
If you do not have the Service Tag, select Detect Product to allow the system to automatically detect your Service Tag, or click View products, and navigate to your product.
- 3 Click **Drivers & Downloads**.  
The drivers that are applicable to your selection are displayed.
- 4 Download the drivers to a USB drive, CD, or DVD.

# Pre-operating system management applications

You can manage basic settings and features of a system without booting to the operating system by using the system firmware.

Topics:

- [Options to manage the pre-operating system applications](#)
- [System Setup](#)

## Options to manage the pre-operating system applications

Your system has the following options to manage the pre-operating system applications:

- System Setup
- Boot Manager
- Dell Lifecycle Controller
- Preboot Execution Environment (PXE)

## System Setup

By using the **System Setup** screen, you can configure the BIOS settings, iDRAC settings, BMC settings, and device settings of your system.

**NOTE:** Help text for the selected field is displayed in the graphical browser by default. To view the help text in the text browser, press F1.

You can access system setup by using two methods:

- Standard graphical browser — The browser is enabled by default.
- Text browser — The browser is enabled by using Console Redirection.

## Viewing System Setup

To view the System Setup screen, perform the following steps:

- 1 Turn on, or restart your system.
- 2 Press F2 immediately after you see the following message:  
F2 = System Setup

**NOTE:** If your operating system begins to load before you press F2, wait for the system to finish booting, and then restart your system and try again.

# System Setup details

Table 24. System Setup Main Menu

Option	Description
System BIOS	Enables you to configure BIOS settings.
iDRAC Settings	Enables you to configure the iDRAC settings. The iDRAC settings utility is an interface to set up and configure the iDRAC parameters by using UEFI (Unified Extensible Firmware Interface). You can enable or disable various iDRAC parameters by using the iDRAC settings utility. For more information about this utility, see Integrated Dell Remote Access Controller User's Guide at <a href="http://Dell.com/idracmanuals">http://Dell.com/idracmanuals</a> .
iDRAC Settings	Enables you to configure BMC settings. The iDRAC settings utility is an interface to set up and configure the BMC parameters by using UEFI. You can enable or disable various BMC parameters by using the iDRAC settings utility. For more information about this utility, see Integrated Dell Remote Access Controller 8 User's Guide at <a href="http://Dell.com/idracmanuals">http://Dell.com/idracmanuals</a> .
Device Settings	Enables you to configure device settings.

## System BIOS

You can use the **System BIOS** screen to edit specific functions such as boot order, system password, setup password, set the RAID mode, and enable or disable USB ports.

## Viewing System BIOS

To view the System BIOS screen, perform the following steps:

- 1 Turn on, or restart your system.
- 2 Press F2 immediately after you see the following message:  
F2 = System Setup  
**NOTE:** If your operating system begins to load before you press F2, wait for the system to finish booting, and then restart your system and try again.
- 3 On the **System Setup Main Menu** screen, click **System BIOS**.

## System BIOS Settings details

The **System BIOS Settings** screen details are explained as follows:

**Table 25. System BIOS Settings**

Option	Description
System Information	Specifies information about the system such as the system model name, BIOS version, and Service Tag.
Memory Settings	Specifies information and options related to the installed memory.
Processor Settings	Specifies information and options related to the processor such as speed and cache size.
SATA Settings	Specifies options to enable or disable the integrated SATA controller and ports.
NVMe Settings	Specifies options to change the NVMe settings.
Boot Settings	Specifies options to specify the Boot mode (BIOS or UEFI). Enables you to modify UEFI and BIOS boot settings.
Network Settings	Specifies options to change the network settings.
Integrated Devices	Specifies options to manage integrated device controllers and ports and specify related features and options.
System Profile Settings	Specifies options to change the processor power management settings, memory frequency, and so on.
System Security	Specifies options to configure the system security settings, such as system password, setup password, Trusted Platform Module (TPM) security. It also manages the power button on the system.
Redundant OS Settings	Specifies the options to configure the Redundant OS settings.
Miscellaneous Settings	Specifies options to change the system date, time, and so on.
Debug Menu	Specifies the debug options.

## Boot Settings

You can use the Boot Settings screen to set the boot mode to either BIOS or UEFI. It also enables you to specify the boot order.

- UEFI: The Unified Extensible Firmware Interface (UEFI) is a new interface between operating systems and platform firmware. The interface consists of data tables with platform related information, also boot and runtime service calls that are available to the operating system and its loader. The following benefits are available when the Boot Mode is set to UEFI:
  - Support for hard drive partitions are larger than 2 TB.
  - Enhanced security (e.g., UEFI Secure Boot).
  - Faster boot time.
- BIOS: The Basic Input/output System (BIOS) is a firmware embedded on the server board. When the system is first started, BIOS activates all of the hardware required by the system to boot including chipset, processor and cache, system memory, internal drives, graphics and audio controllers, and internal expansion cards. After BIOS completes this process, it transfers control of the system to the Operating System that is installed. The method this transfer occurs is controlled by the BIOS Boot Mode, available options being BIOS and UEFI. The BIOS Boot Mode is the legacy boot mode. It is maintained for backward compatibility.

## Viewing Boot Settings

To view the **Boot Settings** screen, perform the following steps:

- 1 Turn on, or restart your system.
- 2 Press F2 immediately after you see the following message:  
F2 = System Setup

**NOTE:** If your operating system begins to load before you press F2, wait for the system to finish booting, and then restart your system and try again.

- 3 On the **System Setup Main Menu** screen, click **System BIOS**.
- 4 On the **System BIOS** screen, click **Boot Settings**.

## Boot Settings details

The Boot Settings screen details are explained as follows:

**Table 26. Boot Settings**

Option	Description
Boot Mode	<p>Enables you to set the boot mode of the system.</p> <p><b>CAUTION:</b> Switching the boot mode may prevent the system from booting if the operating system is not installed in the same boot mode.</p> <p>If the operating system supports UEFI, you can set this option to UEFI. Setting this field to BIOS allows compatibility with non-UEFI operating systems. This option is set to BIOS by default.</p> <p><b>NOTE:</b> Setting this field to UEFI disables the BIOS Boot Settings menu. Setting this field to BIOS disables the UEFI Boot Settings menu.</p>
Boot Sequence Retry	<p>Enables or disables the Boot Sequence Retry feature. If this option is set to Enabled and the system fails to boot, the system re-attempts the boot sequence after 30 seconds. This option is set to Enabled by default.</p>
Hard-Disk Failover	<p>Specifies the hard drive that is booted in the event of a hard drive failure. The devices are selected in the Hard-Disk Drive Sequence on the Boot Option Setting menu. When this option is set to Disabled, only the first hard drive in the list is attempted to boot. When this option is set to Enabled, all hard drives are attempted to boot in the order selected in the Hard-Disk Drive Sequence. This option is not enabled for UEFI Boot Mode.</p>
Boot Option Settings	<p>Configures the boot sequence and the boot devices.</p>
BIOS Boot Settings	<p>Enables or disables BIOS boot options.</p> <p><b>NOTE:</b> This option is enabled only if the boot mode is BIOS.</p>
UEFI Boot Settings	<p>Enables or disables UEFI Boot options. The UEFI options include PXE boot devices.</p> <p><b>NOTE:</b> This option is enabled only if the boot mode is UEFI.</p>
UEFI Boot Sequence	<p>Enables you to change the PXE boot device order.</p>
Boot Options Enable/Disable	<p>Enables you to select the enabled or disabled PXE devices.</p>

## Choosing system boot mode

System Setup enables you to specify one of the following boot modes for installing your operating system:

- BIOS boot mode (the default) is the standard BIOS-level boot interface.
- UEFI (the default) boot mode, is an enhanced 64-bit boot interface. If you have configured your system to boot to UEFI mode, it replaces the system BIOS.

**NOTE:** The system supports only BIOS boot mode.

- 1 From the **System Setup Main Menu**, click **Boot Settings**, and select **Boot Mode**.
- 2 Select the UEFI boot mode you want the system to boot into.

**CAUTION:** Switching the boot mode may prevent the system from booting if the operating system is not installed in the same boot mode.

- 3 After the system boots in the specified boot mode, proceed to install your operating system from that mode.

**NOTE:** Operating systems must be UEFI-compatible to be installed from the UEFI boot mode. DOS and 32-bit operating systems do not support UEFI and can only be installed from the BIOS boot mode.

**NOTE:** For the latest information about supported operating systems, go to <http://Dell.com/ossupport>.

## Changing boot order

Dell EMC does not recommend changing boot order. You may have to change the boot order if you want to boot from a USB key. You may have to change the boot order if you want to boot from a USB key or an optical drive. The following instructions may vary if you have selected **BIOS** for **Boot Mode**.

- 1 On the **System Setup Main Menu** screen, click **System BIOS > Boot Settings**.
- 2 Click **Boot Option Settings > BIOS/UEFI Boot Settings > Boot Sequence**.
- 3 Use the arrow keys to select a boot device, and use the plus (+) and minus (-) sign keys to move the device down or up in the order.
- 4 Click **Exit**, and then click **Yes** to save the settings on exit.

## Network Settings

You can use the **Network Settings** screen to modify PXE device settings. The network settings option is available only in the UEFI mode.

**NOTE:** The BIOS does not control network settings in the BIOS mode. For the BIOS boot mode, the optional Boot ROM of the network controllers handles the network settings.

## Viewing Network Settings

To view the **Network Settings** screen, perform the following steps:

- 1 Turn on, or restart your system.
- 2 Press F2 immediately after you see the following message:  
F2 = System Setup

**NOTE:** If your operating system begins to load before you press F2, wait for the system to finish booting, and then restart your system and try again.

- 3 On the **System Setup Main Menu** screen, click **System BIOS**.
- 4 On the **System BIOS** screen, click **Network Settings**.

## Network Settings screen details

The Network Settings screen details are explained as follows:

**Table 27. Network Settings**

Option	Description
PXE Device n (n = 1 to 4)	Enables or disables the device. When enabled, a UEFI boot option is created for the device.
PXE Device n Settings (n = 1 to 4)	Enables you to control the configuration of the PXE device.
UEFI HTTP Device n Settings (n = 1 to 3)	Enables or disables the UEFI HTTP device settings.

## UEFI iSCSI Settings

You can use the iSCSI Settings screen to modify iSCSI device settings. The iSCSI Settings option is available only in the UEFI boot mode. BIOS does not control network settings in the BIOS boot mode. For the BIOS boot mode, the option ROM of the network controller handles the network settings.

## Viewing UEFI iSCSI Settings

To view the **UEFI iSCSI Settings** screen, perform the following steps:

- 1 Turn on, or restart your system.
- 2 Press F2 immediately after you see the following message:  
F2 = System Setup
- 3 On the **System Setup Main Menu** screen, click **System BIOS**.
- 4 On the **System BIOS** screen, click **Network Settings**.
- 5 On the **Network Settings** screen, click **UEFI iSCSI Settings**.

**NOTE:** If your operating system begins to load before you press F2, wait for the system to finish booting, and then restart your system and try again.

## UEFI iSCSI Settings details

The **UEFI iSCSI Settings** screen details are explained as follows:

**Table 28. UEFI iSCSI Settings**

Option	Description
iSCSI Initiator Name	Specifies the name of the iSCSI initiator (iqn format).
iSCSI Device n (n = 1 to 4) iSCSI Device1	Enables or disables the iSCSI device. When disabled, a UEFI boot option is created for the iSCSI device automatically.

## System Security

You can use the **System Security** screen to perform specific functions such as setting the system password, setup password and disabling the power button.

## Viewing System Security

To view the **System Security** screen, perform the following steps:

- 1 Turn on, or restart your system.
- 2 Press F2 immediately after you see the following message:  
F2 = System Setup

**NOTE:** If your operating system begins to load before you press F2, wait for the system to finish booting, and then restart your system and try again.

- 3 On the **System Setup Main Menu** screen, click **System BIOS**.
- 4 On the **System BIOS** screen, click **System Security**.

## System Security Settings details

The **System Security Settings** screen details are explained as follows:

**Table 29. System Security Settings**

Option	Description
Intel AES-NI	Improves the speed of applications by performing encryption and decryption by using the Advanced Encryption Standard Instruction Set (AES-NI). This option is set to <b>Enabled</b> by default.
System Password	Sets the system password. This option is set to <b>Enabled</b> by default and is read-only if the password jumper is not installed in the system.
Setup Password	Sets the setup password. This option is read-only if the password jumper is not installed in the system.
Password Status	Locks the system password. This option is set to Unlocked by default.
TPM Security	<b>NOTE:</b> The TPM menu is available only when the TPM module is installed. Enables you to control the reporting mode of the TPM. The <b>TPM Security</b> option is set to <b>Off</b> by default. You can only modify the TPM Status, TPM Activation, and the Intel TXT fields if the <b>TPM Status</b> field is set to either <b>On with Pre-boot Measurements</b> or <b>On without Pre-boot Measurements</b> .
TPM Information	Changes the operational state of the TPM. This option is set to <b>No Change</b> by default.
TPM Status	Specifies the TPM status.
TPM Command	Clears all the contents of the TPM. The <b>TPM Clear</b> option is set to <b>No</b> by default. <b>CAUTION:</b> Clearing the TPM results in the loss of all keys in the TPM. The loss of TPM keys may affect booting to the operating system.
Intel TXT	Enables or disables the Intel Trusted Execution Technology (TXT) option. To enable the <b>Intel TXT</b> option, virtualization technology and TPM Security must be enabled with Pre-boot measurements. This option is set to <b>Off</b> by default.
Power Button	Enables or disables the power button on the front of the system. This option is set to <b>Enabled</b> by default.

Option	Description
AC Power Recovery	Sets how the system behaves after AC power is restored to the system. This option is set to <b>Last</b> by default.
AC Power Recovery Delay	Sets the time delay for the system to power up after AC power is restored to the system. This option is set to <b>Immediate</b> by default.
User Defined Delay (60 s to 240 s)	Sets the <b>User Defined Delay</b> option when the <b>User Defined</b> option for <b>AC Power Recovery Delay</b> is selected.
UEFI Variable Access	Provides varying degrees of securing UEFI variables. When set to <b>Standard</b> (the default), UEFI variables are accessible in the operating system per the UEFI specification. When set to <b>Controlled</b> , selected UEFI variables are protected in the environment and new UEFI boot entries are forced to be at the end of the current boot order.
Secure ME PCI Cfg Space	Enabling this setting will hide the PCI configuration space for the Management Engine (ME) HECI devices.
Secure Boot	Enables Secure Boot, where the BIOS authenticates each pre-boot image by using the certificates in the Secure Boot Policy. Secure Boot is disabled by default.
Secure Boot Policy	When Secure Boot policy is set to <b>Standard</b> , the BIOS uses the system manufacturer's key and certificates to authenticate pre-boot images. When Secure Boot policy is set to <b>Custom</b> , the BIOS uses the user-defined key and certificates. Secure Boot policy is set to <b>Standard</b> by default.
Secure Boot Mode	Configures how the BIOS uses the Secure Boot Policy Objects (PK, KEK, db, dbx). <ul style="list-style-type: none"> <li>• <b>User Mode:</b> In <b>User Mode</b>, PK must be installed, and BIOS performs signature verification on programmatic attempts to update policy objects. The BIOS allows unauthenticated programmatic transitions between modes.</li> <li>• <b>Audit Mode:</b> In <b>Audit Mode</b>, PK is not present. The BIOS does not authenticate programmatic updates to the policy objects, and transitions between modes. Audit Mode is useful for programmatically determining a working set of policy objects. BIOS performs signature verification on pre-boot images and logs results in the image Execution Information Table, but executes the images whether they pass or fail verification.</li> <li>• <b>Deployed Mode:</b> <b>Deployed Mode</b> is the most secure mode. In <b>Deployed Mode</b>, PK must be installed and the BIOS performs signature verification on programmatic attempts to update policy objects. <b>Deployed Mode</b> restricts the programmatic mode transitions</li> </ul>
Secure Boot Policy Summary	Specifies the list of certificates and hashes that secure boot uses to authenticate images.
Secure Boot Custom Policy Settings	Configures the Secure Boot Custom Policy.

## Creating a system and setup password

Ensure that the password jumper is enabled. The password jumper enables or disables the system password and setup password features. For more information, see the Server board jumper settings section.

**NOTE:** If the password jumper setting is disabled, the existing system password and setup password are deleted and you need not provide the system password to boot the system.

- 1 To enter System Setup, press F2 immediately after turning on or rebooting your system.
- 2 On the **System Setup Main Menu** screen, click **System BIOS > System Security**.
- 3 On the **System Security** screen, verify that **Password Status** is set to **Unlocked**.
- 4 In the **System Password** field, type your system password, and press Enter or Tab.  
Use the following guidelines to assign the system password:

- A password can have up to 32 characters.
- The password can contain the numbers 0 through 9.
- Only the following special characters are allowed: space, (h), (+), (.), (-), (.), (/), (:), ([), (\), (]), (').

A message prompts you to reenter the system password.

- 5 Reenter the system password, and click **OK**.  
In the **Setup Password** field, type your setup password and press Enter or Tab.
- 6 A message prompts you to reenter the setup password.
- 7 Reenter the setup password, and click **OK**.
- 8 Press Esc to return to the System BIOS screen. Press Esc again.  
A message prompts you to save the changes.

**NOTE:** Password protection does not take effect until the system reboots.

## Using your system password to secure your system

If you have assigned a setup password, the system accepts your setup password as an alternate system password.

- 1 Turn on or reboot your system.
- 2 Type the system password and press Enter.

When **Password Status** is set to **Locked**, type the system password and press Enter when prompted at reboot.

**NOTE:** If an incorrect system password is typed, the system displays a message and prompts you to reenter your password. You have three attempts to type the correct password. After the third unsuccessful attempt, the system displays an error message that the system has stopped functioning and must be turned off. Even after you turn off and restart the system, the error message is displayed until the correct password is entered.

## Deleting or changing system and setup password

**NOTE:** You cannot delete or change an existing system or setup password if the Password Status is set to Locked.

- 1 To enter System Setup, press F2 immediately after turning on or restarting your system.
- 2 On the **System Setup Main Menu** screen, click **System BIOS System Security**.
- 3 On the **System Security** screen, ensure that **Password Status** is set to **Unlocked**.
- 4 In the **System Password** field, alter or delete the existing system password, and then press Enter or Tab.
- 5 In the **Setup Password** field, alter or delete the existing setup password, and then press Enter or Tab.  
If you change the system and setup password, a message prompts you to reenter the new password. If you delete the system and setup password, a message prompts you to confirm the deletion.
- 6 Press Esc to return to the **System BIOS** screen. Press Esc again, and a message prompts you to save the changes.
- 7 Select **Setup Password**, change, or delete the existing setup password and press Enter or Tab.

**NOTE:** If you change the system password or setup password, a message prompts you to reenter the new password. If you delete the system password or setup password, a message prompts you to confirm the deletion.

## Operating with setup password enabled

If **Setup Password** is set to **Enabled**, type the correct setup password before modifying the system setup options.

If you do not type the correct password in three attempts, the system displays the following message:

```
Invalid Password! Number of unsuccessful password attempts: <x> System Halted! Must power down.
```

Even after you turn off and restart the system, the error message is displayed until the correct password is typed. The following options are exceptions:

- If **System Password** is not set to **Enabled** and is not locked through the **Password Status** option, you can assign a system password. For more information, see the System Security Settings screen section.
- You cannot disable or change an existing system password.

**NOTE:** You can use the password status option with the setup password option to protect the system password from unauthorized changes.

## System Information

You can use the **System Information** screen to view system properties such as Service Tag, system model name, and the BIOS version.

## Viewing System Information

To view the **System Information** screen, perform the following steps:

- 1 Turn on, or restart your system.
- 2 Press F2 immediately after you see the following message:  
F2 = System Setup

**NOTE:** If your operating system begins to load before you press F2, wait for the system to finish booting, and then restart your system and try again.

- 3 On the **System Setup Main Menu** screen, click **System BIOS**.
- 4 On the **System BIOS** screen, click **System Information**.

## System Information details

The **System Information** screen details are explained as follows:

**Table 30. System Information**

Option	Description
System Model Name	Specifies the system model name.
System BIOS Version	Specifies the BIOS version installed on the system.
System Management Engine Version	Specifies the current version of the Management Engine firmware.
System Service Tag	Specifies the system Service Tag.
System Manufacturer	Specifies the name of the system manufacturer
System Manufacturer Contact Information	Specifies the contact information of the system manufacturer.
System CPLD Version	Specifies the current version of the system complex programmable logic device (CPLD) firmware.
UEFI Compliance Version	Specifies the UEFI compliance level of the system firmware.

# Memory Settings

You can use the **Memory Settings** screen to view all the memory settings and enable or disable specific memory functions, such as system memory testing and node interleaving.

## Viewing Memory Settings

To view the **Memory Settings** screen, perform the following steps:

- 1 Turn on, or restart your system.
- 2 Press F2 immediately after you see the following message:  
F2 = System Setup

**NOTE:** If your operating system begins to load before you press F2, wait for the system to finish booting, and then restart your system and try again.

- 3 On the **System Setup Main Menu** screen, click **System BIOS**.
- 4 On the **System BIOS** screen, click **Memory Settings**.

## Memory Settings details

The **Memory Settings** screen details are explained as follows:

**Table 31. The Memory Settings screen details are explained as follows:**

Option	Description
System Memory Size	Specifies the memory size in the system.
System Memory Type	Specifies the type of memory installed in the system.
System Memory Speed	Specifies the system memory speed.
System Memory Voltage	Specifies the system memory voltage.
Video Memory	Specifies the amount of video memory.
System Memory Testing	Specifies whether the system memory tests are run during system boot. Options are <b>Enabled</b> and <b>Disabled</b> . This option is set to <b>Disabled</b> by default.
Memory Operating Mode	Specifies the memory operating mode. The available option is <b>Optimizer Mode</b> .
Memory Operating Mode	Specifies the memory operating mode. The options available are <b>Optimizer Mode</b> , <b>Single Rank Spare Mode</b> , <b>Multi Rank Spare Mode</b> , <b>Mirror Mode</b> , and <b>Dell Fault Resilient Mode</b> . This option is set to <b>Optimizer Mode</b> by default.  <b>NOTE:</b> The Memory Operating Mode option can have different default and available options based on the memory configuration of your system.  <b>NOTE:</b> The Dell Fault Resilient Mode option establishes an area of memory that is fault resilient. This mode can be used by an operating system that supports the feature to load critical applications or enables the operating system kernel to maximize system availability.

Option	Description
Memory Operating Mode	Specifies the memory operating mode. The options available are <b>Optimizer Mode</b> , <b>Advanced ECC Mode</b> , <b>Mirror Mode</b> , <b>Spare Mode</b> , <b>Spare with Advanced ECC Mode</b> . This option is set to <b>Optimizer Mode</b> by default.   <b>NOTE: The Memory Operating Mode option can have different default and available options based on the memory configuration of your system.</b>
Current State of Memory Operating Mode	Specifies the current state of the memory operating mode.
Node Interleaving	Specifies if Non-Uniform Memory Architecture (NUMA) is supported. If this field is set to <b>Enabled</b> , memory interleaving is supported if a symmetric memory configuration is installed. If the field is set to <b>Disabled</b> , the system supports NUMA (asymmetric) memory configurations. This option is set to <b>Disabled</b> by default.
Snoop Mode	Specifies the <b>Snoop Mode</b> options. The <b>Snoop Mode</b> options available are <b>Home Snoop</b> , <b>Early Snoop</b> , and <b>Cluster on Die</b> . This option is set to <b>Early Snoop</b> by default. This field is available only when the <b>Node Interleaving</b> is set to <b>Disabled</b> .

## Processor Settings

You can use the **Processor Settings** screen to view the processor settings, and perform specific functions such as enabling virtualization technology, hardware prefetcher, logical processor idling, and opportunistic self-refresh.

## Viewing Processor Settings

To view the **Processor Settings** screen, perform the following steps:



- 1 Turn on, or restart your system.
- 2 Press F2 immediately after you see the following message:  
F2 = System Setup  
  
 **NOTE: If your operating system begins to load before you press F2, wait for the system to finish booting, and then restart your system and try again.**
- 3 On the **System Setup Main Menu** screen, click **System BIOS**.
- 4 On the **System BIOS** screen, click **Processor Settings**.

## Processor Settings details

The Processor Settings screen details are explained as follows:

**Table 32. Processor Settings**

Option	Description
Logical Processor	Enables or disables the logical processors and displays the number of logical processors. If this option is set to <b>Enabled</b> , the BIOS displays all the logical processors. If this option is set to <b>Disabled</b> , the BIOS displays only one logical processor per core. This option is set to <b>Enabled</b> by default.
Virtualization Technology	Enables or disables the virtualization technology for the processor. This option is set to <b>Enabled</b> by default.

Option	Description
Adjacent Cache Line Prefetch	Optimizes the system for applications that need high utilization of sequential memory access. This option is set to <b>Enabled</b> by default. You can disable this option for applications that need high utilization of random memory access.
Hardware Prefetcher	Enables or disables the hardware prefetcher. This option is set to <b>Enabled</b> by default.
DCU Streamer Prefetcher	Enables or disables the Data Cache Unit (DCU) streamer prefetcher. This option is set to <b>Enabled</b> by default.
DCU IP Prefetcher	Enables or disables the Data Cache Unit (DCU) IP prefetcher. This option is set to <b>Enabled</b> by default.
Sub NUMA Cluster	Enables or disables the Sub NUMA Cluster. This option is set to <b>Enabled</b> by default.
Logical Processor Idling	Enables you to improve the energy efficiency of a system. It uses the operating system core parking algorithm and parks some of the logical processors in the system which in turn allows the corresponding processor cores to transition into a lower power idle state. This option can only be enabled if the operating system supports it. It is set to <b>Disabled</b> by default.
Configurable TDP	Enables you to reconfigure the processor Thermal Design Power (TDP) levels during POST based on the power and thermal delivery capabilities of the system. TDP verifies the maximum heat the cooling system is needed to dissipate. This option is set to <b>Nominal</b> by default.   <b>NOTE: This option is only available on certain stock keeping units (SKUs) of the processors.</b>
X2Apic Mode	Enables or disables the X2Apic mode.
Dell Controlled Turbo	Controls the turbo engagement. Enable this option only when <b>System Profile</b> is set to <b>Performance</b> .   <b>NOTE: Depending on the number of installed CPUs, there may be up to four processor listings.</b>
X2Apic Mode	Displays the X2Apic Mode setting that is read only and permanently set to enabled.
Number of Cores per Processor	Controls the number of enabled cores in each processor. This option is set to <b>All</b> by default.
Processor Core Speed	Specifies the maximum core frequency of the processor.
Processor 1	 <b>NOTE: Depending on the number of CPUs, there may be up to four processors listed.</b>  The following settings are displayed for each processor installed in the system: <ul style="list-style-type: none"> <li>• <b>Family-Model-Stepping:</b> Specifies the family, model, and stepping of the processor as defined by Intel.</li> <li>• <b>Brand:</b> Specifies the brand name.</li> <li>• <b>Level 2 Cache:</b> Specifies the total L2 cache.</li> <li>• <b>Level 3 Cache:</b> Specifies the total L3 cache.</li> <li>• <b>Number of Cores:</b> Specifies the number of cores per processor.</li> </ul>

## SATA Settings

You can use the **SATA Settings** screen to view the SATA settings of SATA devices.

## Viewing SATA Settings

To view the **SATA Settings** screen, perform the following steps:

- 1 Turn on, or restart your system.
- 2 Press F2 immediately after you see the following message:  
F2 = System Setup
- 3 On the **System Setup Main Menu** screen, click **System BIOS**.
- 4 On the **System BIOS** screen, click **SATA Settings**.

**NOTE:** If your operating system begins to load before you press F2, wait for the system to finish booting, and then restart your system and try again.

## SATA Settings details

The **SATA Settings** screen details are explained as follows:

**Table 33. SATA Settings**

Option	Description
Embedded SATA	Enables the embedded SATA option to be set to <b>AHCI</b> , or <b>RAID</b> modes. This option is set to <b>AHCI</b> by default.
Security Freeze Lock	Sends <b>Security Freeze Lock</b> command to the embedded SATA drives during POST. This option is applicable only for ATA and AHCI mode.
Write Cache	Enables or disables the command for the embedded SATA drives during POST.
Port A	<p>Sets the drive type of the selected device. For the <b>Embedded SATA settings</b> in ATA mode, set this field to <b>Auto</b> to enable BIOS support. Set it to <b>OFF</b> to turn off BIOS support.</p> <p>For <b>AHCI</b> mode, BIOS support is always enabled.</p> <ul style="list-style-type: none"> <li>• <b>Model:</b> Specifies the drive model of the selected device.</li> <li>• <b>Drive Type:</b> Specifies the type of drive attached to the SATA port.</li> <li>• <b>Capacity:</b> Specifies the total capacity of the hard drive. This field is undefined for removable media devices such as optical drives.</li> </ul>
Port B	<p>Sets the drive type of the selected device. For the <b>Embedded SATA settings</b> in ATA mode, set this field to <b>Auto</b> to enable BIOS support. Set it to <b>OFF</b> to turn off BIOS support.</p> <p>For <b>AHCI</b> mode, BIOS support is always enabled.</p> <ul style="list-style-type: none"> <li>• <b>Model:</b> Specifies the drive model of the selected device.</li> <li>• <b>Drive Type:</b> Specifies the type of drive attached to the SATA port.</li> <li>• <b>Capacity:</b> Specifies the total capacity of the hard drive. This field is undefined for removable media devices such as optical drives.</li> </ul>
Port C	<p>Sets the drive type of the selected device. For the <b>Embedded SATA settings</b> in ATA mode, set this field to <b>Auto</b> to enable BIOS support. Set it to <b>OFF</b> to turn off BIOS support.</p>

Option	Description
	<p>For <b>AHCI</b> mode, BIOS support is always enabled.</p> <ul style="list-style-type: none"> <li>• <b>Model:</b> Specifies the drive model of the selected device.</li> <li>• <b>Drive Type:</b> Specifies the type of drive attached to the SATA port.</li> <li>• <b>Capacity:</b> Specifies the total capacity of the hard drive. This field is undefined for removable media devices such as optical drives.</li> </ul>
Port D	<p>Sets the drive type of the selected device. For the <b>Embedded SATA settings</b> in <b>ATA</b> mode, set this field to <b>Auto</b> to enable BIOS support. Set it to <b>OFF</b> to turn off BIOS support.</p> <p>For <b>AHCI</b> mode, BIOS support is always enabled.</p> <ul style="list-style-type: none"> <li>• <b>Model:</b> Specifies the drive model of the selected device.</li> <li>• <b>Drive Type:</b> Specifies the type of drive attached to the SATA port.</li> <li>• <b>Capacity:</b> Specifies the total capacity of the hard drive. This field is undefined for removable media devices such as optical drives.</li> </ul>
Port E	<p>Sets the drive type of the selected device. For the <b>Embedded SATA settings</b> in <b>ATA</b> mode, set this field to <b>Auto</b> to enable BIOS support. Set it to <b>OFF</b> to turn off BIOS support.</p> <p>For <b>AHCI</b> mode, BIOS support is always enabled.</p> <ul style="list-style-type: none"> <li>• <b>Model:</b> Specifies the drive model of the selected device.</li> <li>• <b>Drive Type:</b> Specifies the type of drive attached to the SATA port.</li> <li>• <b>Capacity:</b> Specifies the total capacity of the hard drive. This field is undefined for removable media devices such as optical drives.</li> </ul>
Port F	<p>Sets the drive type of the selected device. For the <b>Embedded SATA settings</b> in <b>ATA</b> mode, set this field to <b>Auto</b> to enable BIOS support. Set it to <b>OFF</b> to turn off BIOS support.</p> <p>For <b>AHCI</b> mode, BIOS support is always enabled.</p> <ul style="list-style-type: none"> <li>• <b>Model:</b> Specifies the drive model of the selected device.</li> <li>• <b>Drive Type:</b> Specifies the type of drive attached to the SATA port.</li> <li>• <b>Capacity:</b> Specifies the total capacity of the hard drive. This field is undefined for removable media devices such as optical drives.</li> </ul>
Port G	<p>Sets the drive type of the selected device. For the <b>Embedded SATA settings</b> in <b>ATA</b> mode, set this field to <b>Auto</b> to enable BIOS support. Set it to <b>OFF</b> to turn off BIOS support.</p> <p>For <b>AHCI</b> mode, BIOS support is always enabled.</p>
Port H	<p>Sets the drive type of the selected device. For the <b>Embedded SATA settings</b> in <b>ATA</b> mode, set this field to <b>Auto</b> to enable BIOS support. Set it to <b>OFF</b> to turn off BIOS support.</p> <p>For <b>AHCI</b> mode, BIOS support is always enabled.</p> <ul style="list-style-type: none"> <li>• <b>Model:</b> Specifies the drive model of the selected device.</li> <li>• <b>Drive Type:</b> Specifies the type of drive attached to the SATA port.</li> <li>• <b>Capacity:</b> Specifies the total capacity of the hard drive. This field is undefined for removable media devices such as optical drives.</li> </ul>

Option	Description
Port I	<p>Sets the drive type of the selected device. For the <b>Embedded SATA settings</b> in <b>ATA</b> mode, set this field to <b>Auto</b> to enable BIOS support. Set it to <b>OFF</b> to turn off BIOS support.</p> <p>For <b>AHCI</b> mode, BIOS support is always enabled.</p> <ul style="list-style-type: none"> <li>• <b>Model:</b> Specifies the drive model of the selected device.</li> <li>• <b>Drive Type:</b> Specifies the type of drive attached to the SATA port.</li> <li>• <b>Capacity:</b> Specifies the total capacity of the hard drive. This field is undefined for removable media devices such as optical drives.</li> </ul>
Port J	<p>Sets the drive type of the selected device. For the <b>Embedded SATA settings</b> in <b>ATA</b> mode, set this field to <b>Auto</b> to enable BIOS support. Set it to <b>OFF</b> to turn off BIOS support.</p> <p>For <b>AHCI</b> mode, BIOS support is always enabled.</p> <ul style="list-style-type: none"> <li>• <b>Model:</b> Specifies the drive model of the selected device.</li> <li>• <b>Drive Type:</b> Specifies the type of drive attached to the SATA port.</li> <li>• <b>Capacity:</b> Specifies the total capacity of the hard drive. This field is undefined for removable media devices such as optical drives.</li> </ul>

## Integrated Devices

You can use the **Integrated Devices** screen to view and configure the settings of all integrated devices including the video controller, integrated RAID controller, and the USB ports.

## Viewing Integrated Devices

To view the **Integrated Devices** screen, perform the following steps:

- 1 Turn on, or restart your system.
  - 2 Press F2 immediately after you see the following message:  
F2 = System Setup
- NOTE:** If your operating system begins to load before you press F2, wait for the system to finish booting, and then restart your system and try again.
- 3 On the **System Setup Main Menu** screen, click **System BIOS**.
  - 4 On the **System BIOS** screen, click **Integrated Devices**.

## Integrated Devices details

The **Integrated Devices** screen details are explained as follows:

**Table 34. Integrated Devices**

Option	Description
User Accessible USB Ports	Enables or disables the USB ports. Selecting <b>All Ports Off</b> disables all USB ports. The USB keyboard and mouse operate during boot process in certain operating systems. After the boot process is complete, the USB keyboard and mouse do not work if the ports are disabled.

Option	Description
	 <b>NOTE: Selecting All Ports Off disables the USB management port and also restricts access to the iDRAC features.</b>
Internal USB Port 1	Enables or disables the internal USB port.
Internal USB Port 2	Enables or disables the internal USB port.
Internal USB Port	Enables or disables the internal USB port. This option is set to <b>On</b> or <b>Off</b> .
Embedded NIC1	Enables or disables the Embedded NIC1 port. The option is set to Enabled by default.
iDRAC Direct USB Port	Enables or disables the internal USB port. This option is set to <b>On</b> or <b>Off</b> .
I/OAT DMA Engine	Enables or disables the I/OAT option. Enable only if the hardware and software support the feature.
Embedded Video Controller	Enables or disables the <b>Embedded Video Controller</b> option. This option is set to <b>Enabled</b> by default.
Current State of Embedded Video Controller	Displays the current state of the embedded video controller. The <b>Current State of Embedded Video Controller</b> option is a read-only field. If the Embedded Video Controller is the only display capability in the system (that is, no add-in graphics card is installed), then the <b>Embedded Video Controller</b> is automatically used as the primary display even if the <b>Embedded Video Controller</b> setting is set to <b>Disabled</b> .
SR-IOV Global Enable	Enables or disables the BIOS configuration of Single Root I/O Virtualization (SR-IOV) devices. This option is set to <b>Disabled</b> by default.
OS Watchdog Timer	If your system stops responding, this watchdog timer aids in the recovery of your operating system. When this option is set to <b>Enabled</b> , the operating system initializes the timer. When this option is set to <b>Disabled</b> (the default), the timer does not have any effect on the system.
Memory Mapped I/O above 4 GB	Enables or disables the support for the PCIe devices that need large amounts of memory. This option is set to <b>Enabled</b> by default.
Memory Mapped I/O above Base	Enables the memory mapped base to either 56 TB, or 12 TB, or 512 GB. The default option is set to 56 TB.
Slot Disablement	<p>Enables or disables the available PCIe slots on your system. The slot disablement feature controls the configuration of the PCIe cards installed in the specified slot. Slots must be disabled only when the installed peripheral card prevents booting into the operating system or causes delays in system startup. If the slot is disabled, both the Option ROM and UEFI drivers are disabled.</p> <ul style="list-style-type: none"> <li>• <b>Slot 1:</b> Enables or disables the PCIe slot 1. This option is set to <b>Enabled</b> by default</li> <li>• <b>Slot 3:</b> Enables or disables or only the boot driver is disabled for the PCIe slot 3. This option is set to <b>Enabled</b> by default</li> <li>• <b>Slot 4:</b> Enables or disables or only the boot driver is disabled for the PCIe slot 3. This option is set to <b>Enabled</b> by default</li> <li>• <b>Slot 5:</b> Enables or disables or only the boot driver is disabled for the PCIe slot 3. This option is set to <b>Enabled</b> by default</li> </ul>
Slot Bifurcation	<p>Allows Platform Manual Bifurcation Control</p> <ul style="list-style-type: none"> <li>• Slot1/3/4/5/6: X16 or X8 or X4 or X8X4X4 or X4X4X8</li> </ul>

# Serial Communication

You can use the **Serial Communication** screen to view the properties of the serial communication port.

## Viewing Serial Communication

To view the **Serial Communication** screen, perform the following steps:

- 1 Turn on, or restart your system.
- 2 Press F2 immediately after you see the following message:  
F2 = System Setup
- 3 On the **System Setup Main Menu** screen, click **System BIOS**.
- 4 On the **System BIOS** screen, click **Serial Communication**.

**NOTE:** If your operating system begins to load before you press F2, wait for the system to finish booting, and then restart your system and try again.

## Serial Communication details

The **Serial Communication** screen details are explained as follows:

**Table 35. Serial Communication**

Option	Description
Serial Communication	<p>Selects serial communication devices (Serial Device 1 and Serial Device 2) in BIOS. BIOS console redirection can also be enabled, and the port address can be specified. This option is set to <b>Auto</b> by default.</p> <p>Enables the <b>COM</b> port or <b>Console Redirection</b> options. This option is set to <b>Off</b> by default.</p> <p>Selects serial communication devices (Serial Device 1 and Serial Device 2) in BIOS. Enables the <b>COM1</b> port. This option is set to <b>On with Console Redirection via COM1</b> by default.</p>
Serial Port Address	<p>Enables you to set the port address for serial devices. This option is set to <b>Serial Device1=COM1, Serial Device 2 = COM2Serial Device 1=COM2, Serial Device 2=COM1</b> by default.</p> <p><b>NOTE:</b> You can use only Serial Device 2 for the Serial Over LAN (SOL) feature. To use console redirection by SOL, configure the same port address for console redirection and the serial device.</p> <p><b>NOTE:</b> Every time the system boots, the BIOS syncs the serial MUX setting saved in iDRAC. The serial MUX setting can independently be changed in iDRAC. Loading the BIOS default settings from within the BIOS setup utility may not always revert the serial MUX setting to the default setting of Serial Device 1.</p>
External Serial Connector	<p>Enables you to associate the External Serial Connector to Serial Device 1, Serial Device 2, or the Remote Access Device by using this option.</p> <p><b>NOTE:</b> Only Serial Device 2 can be used for Serial Over LAN (SOL). To use console redirection by SOL, configure the same port address for console redirection and the serial device.</p>

Option	Description
	<p><b>NOTE:</b> Every time the system boots, the BIOS syncs the serial MUX setting saved in iDRAC. The serial MUX setting can independently be changed in iDRAC. Loading the BIOS default settings from within the BIOS setup utility may not always revert this setting to the default setting of Serial Device 1.</p> <p>Enables you to associate the External Serial Connector to Serial Device 1.</p>
Failsafe Baud Rate	Specifies the failsafe baud rate for console redirection. The BIOS attempts to determine the baud rate automatically. This failsafe baud rate is used only if the attempt fails, and the value must not be changed. This option is set to 115200 by default.
Remote Terminal Type	Sets the remote console terminal type. This option is set to ANSIVT 100/VT 220 by default.
Redirection After Boot	Enables or disables the BIOS console redirection when the operating system is loaded. This option is set to <b>Enabled</b> by default.

## System Profile Settings

You can use the **System Profile Settings** screen to enable specific system performance settings such as power management.

## Viewing System Profile Settings

To view the **System Profile Settings** screen, perform the following steps:





- 1 Turn on, or restart your system.
  - 2 Press F2 immediately after you see the following message:  
F2 = System Setup
- NOTE:** If your operating system begins to load before you press F2, wait for the system to finish booting, and then restart your system and try again.
- 3 On the **System Setup Main Menu** screen, click **System BIOS**.
  - 4 On the **System BIOS** screen, click **System Profile Settings**.

## System Profile Settings details

The **System Profile Settings** screen details are explained as follows:

**Table 36. System Profile Settings**

Option	Description
System Profile	Sets the system profile. If you set the System Profile option to a mode other than <b>Custom</b> , the BIOS automatically sets the rest of the options. You can only change the rest of the options if the mode is set to <b>Custom</b> . This option is set to <b>Performance Per Watt Optimized (DAPC)</b> by default. DAPC is Dell Active Power Controller., other options include <b>Performance Per Watt (OS)</b> , <b>Performance Per Watt (HWPM)</b> , <b>Performance</b> , and <b>Workstation Performance</b> .

Option	Description
	<p> <b>NOTE: All the parameters on the system profile setting screen are available only when the System Profile option is set to Custom.</b></p>
CPU Power Management	Sets the CPU power management. This option is set to <b>System DBPM (DAPC)</b> by default. DBPM is Demand-Based Power Management. Other options include <b>OS DBPM</b> , <b>Maximum Performance</b> , and <b>Hardware P States</b> .
Memory Frequency	Sets the speed of the system memory. You can select <b>Maximum Performance</b> , <b>Maximum Reliability</b> , or a specific speed.
Turbo Boost	Enables or disables the processor to operate in the turbo boost mode. This option is set to <b>Enabled</b> by default.
Energy Efficient Turbo	Enables or disables the <b>Energy Efficient Turbo</b> option.  Energy Efficient Turbo (EET) is a mode of operation where a processor's core frequency is adjusted to be within the turbo range based on workload.
C1E	Enables or disables the processor to switch to a minimum performance state when it is idle. This option is set to <b>Enabled</b> by default.
C States	Enables or disables the processor to operate in all available power states. This option is set to <b>Enabled</b> by default.
Write Data CRC	Enables or disables the Write Data CRC. This option is set to <b>Enabled</b> by default.
Collaborative CPU Performance Control	Enables or disables the CPU power management option. When set to Enabled, the CPU power management is controlled by the OS DBPM and the System DBPM (DAPC). This option is set to <b>Disabled</b> by default.
Memory Patrol Scrub	Sets the memory patrol scrub frequency. This option is set to Standard by default.
Memory Refresh Rate	Sets the memory refresh rate to either 1x or 2x. This option is set to <b>1x</b> by default.
Uncore Frequency	Enables you to select the <b>Processor Uncore Frequency</b> option.  Dynamic mode enables the processor to optimize power resources across the cores and uncore during runtime. The optimization of the uncore frequency to either save power or optimize performance is influenced by the setting of the <b>Energy Efficiency Policy</b> option.
Energy Efficient Polic	Enables you to select the <b>Energy Efficient Policy</b> option.  The CPU uses the setting to manipulate the internal behavior of the processor and determines whether to target higher performance or better power savings.
Number of Turbo Boot Enabled Cores for Processor 1	<p> <b>NOTE: If there are two processors installed in the system, you see an entry for Number of Turbo Boost Enabled Cores for Processor 2.</b></p> <p>Controls the number of turbo boost enabled cores for processor 1. The maximum number of cores is enabled by default.</p>
Monitor/Mwait	<p>Enables the Monitor/Mwait instructions in the processor. This option is set to <b>Enabled</b> for all system profiles, except <b>Custom</b> by default.</p> <p> <b>NOTE: This option can be disabled only if the C States option in the Custom mode is set to disabled.</b></p> <p> <b>NOTE: When C States is set to Enabled in the Custom mode, changing the Monitor/Mwait setting does not impact the system power or performance.</b></p>

Option	Description
CPU Interconnect Bus Link Power Management	Enables or disables the CPU Interconnect Bus Link Power Management. This option is set to <b>Enabled</b> by default.
PCI ASPM L1 Link Power Management	Enables or disables the PCI ASPM L1 Link Power Management. This option is set to <b>Enabled</b> by default.

## Miscellaneous Settings

You can use the **Miscellaneous Settings** screen to perform specific functions such as updating the asset tag and changing the system date and time.

## Viewing Miscellaneous Settings

To view the **Miscellaneous Settings** screen, perform the following steps:

- 1 Turn on, or restart your system.
- 2 Press F2 immediately after you see the following message:  
F2 = System Setup

**NOTE:** If your operating system begins to load before you press F2, wait for the system to finish booting, and then restart your system and try again.

- 3 On the **System Setup Main Menu** screen, click **System BIOS**.
- 4 On the **System BIOS** screen, click **Miscellaneous Settings**.

## Miscellaneous Settings details

The **Miscellaneous Settings** screen details are explained as follows:

**Table 37. Miscellaneous Settings**

Option	Description
System Time	Enables you to set the time on the system.
System Date	Enables you to set the date on the system.
Asset Tag	Specifies the asset tag and enables you to modify it for security and tracking purposes.
Keyboard NumLock	Enables you to set whether the system boots with the NumLock enabled or disabled. This option is set to On by default.  <b>NOTE:</b> This option does not apply to 84-key keyboards.
F1/F2 Prompt on Error	Enables or disables the F1/F2 prompt on error. This option is set to Enabled by default. The F1/F2 prompt also includes keyboard errors.
Load Legacy Video Option ROM	Enables you to determine whether the system BIOS loads the legacy video (INT 10H) option ROM from the video controller. Selecting <b>Enabled</b> in the operating system does not support UEFI video output standards. This field is available only for UEFI boot mode. You cannot set the option to <b>Enabled</b> if <b>UEFI Secure Boot</b> mode is enabled.
In-System Characterization	Enables or disables <b>In-System Characterization</b> . This option is set to <b>Disabled</b> by default. The two other options are <b>Enabled</b> and <b>Enabled - No Reboot</b> .

Option	Description
	<p><b>NOTE:</b> The default setting for In-System Characterization is subject to change in future BIOS releases.</p> <p>When enabled, In-System Characterization (ISC) executes during POST upon detecting relevant changes in system configuration to optimize system power and performance. ISC takes about 20 seconds to execute, and system reset is needed for ISC results to be applied. The <b>Enabled - No Reboot</b> option executes ISC and continues without applying ISC results until the next time system reset occurs. The <b>Enabled</b> option executes ISC and forces an immediate system reset so that ISC results can be applied. It takes the system longer to be ready due to the forced system reset. When disabled, ISC does not execute.</p>
Dell Wyse P25/P45 BIOS Access	Enables or disables the Dell Wyse P25/P45 BIOS Access. This option is set to <b>Enabled</b> by default.
Power Cycle Request	Enables or disables the Power Cycle Request. This option is set to <b>None</b> by default.

## iDRAC Settings utility

The iDRAC settings utility is an interface to set up and configure the iDRAC parameters by using UEFI. You can enable or disable various iDRAC parameters by using the iDRAC settings utility.

**NOTE:** Accessing some of the features on the iDRAC settings utility needs the iDRAC Enterprise License upgrade.

For more information about using iDRAC, see Dell Integrated Dell Remote Access Controller User's Guide at [Dell.com/idracmanuals](http://Dell.com/idracmanuals).

## Entering the iDRAC Settings utility

- 1 Turn on or restart the managed system.
- 2 Press F2 during Power-on Self-test (POST).
- 3 On the **System Setup Main Menu** page, click **iDRAC Settings**.  
The **iDRAC Settings** screen is displayed.

## Changing thermal settings

The iDRAC settings utility enables you to select and customize the thermal control settings for your system.

**NOTE:** Selection of thermal profile does not change the default Fan speed. Fan speed automatically changes as per the system temperature irrespective of the THERMAL PROFILE in effect or select the Custom fan speed option to set it to desired speed.

- 1 Click **iDRAC Settings > Thermal**.
- 2 Under **SYSTEM THERMAL PROFILE > Thermal Profile**, select one of the following options:
  - Default Thermal Profile Settings
  - Maximum Performance (Optimized)
  - Minimum Power (Performance per Watt Optimized)
- 3 Under **USER COOLING OPTIONS**, set the **Fan Speed Offset**, **Minimum Fan Speed**, and **Custom Minimum Fan Speed**.
- 4 Click **Back > Finish > Yes**.

## Device Settings

Device Settings enables you to configure device parameters.

## Dell Lifecycle Controller

Dell Lifecycle Controller (LC) provides advanced embedded systems management capabilities including system deployment, configuration, update, maintenance, and diagnosis. LC is delivered as part of the iDRAC out-of-band solution and Dell system embedded Unified Extensible Firmware Interface (UEFI) applications.

## Embedded system management

The Dell Lifecycle Controller provides advanced embedded system management throughout the system's lifecycle. The Dell Lifecycle Controller can be started during the boot sequence and can function independently of the operating system.

**NOTE:** Certain platform configurations may not support the full set of features provided by the Dell Lifecycle Controller.

For more information about setting up the Dell Lifecycle Controller, configuring hardware and firmware, and deploying the operating system, see the Dell Lifecycle Controller documentation at <http://Dell.com/idracmanuals>.

## Boot Manager

The **Boot Manager** screen enables you to select boot options and diagnostic utilities.

## Viewing Boot Manager

To enter Boot Manager:

- 1 Turn on, or restart your system.  
Enter the result of your step here (optional).
- 2 Press F11 when you see the following message:  
F11 = Boot Manager  
If your operating system begins to load before you press F11, allow the system to complete the booting, and then restart your system and try again.

## Boot Manager main menu

Table 38. Boot Manager main menu

Menu item	Description
Continue Normal Boot	The system attempts to boot to devices starting with the first item in the boot order. If the boot attempt fails, the system continues with the next item in the boot order until the boot is successful or no more boot options are found.
One-shot Boot Menu	Enables you to access boot menu, where you can select a one-time boot device to boot from.

Menu item	Description
Launch System Setup	Enables you to access System Setup.
Launch Lifecycle Controller	Exits the Boot Manager and invokes the Dell Lifecycle Controller program.
System Utilities	Enables you to launch System Utilities menu such as System Diagnostics and UEFI shell.

## One-shot BIOS boot menu

One-shot BIOS boot menu enables you to select a boot device to boot from.

## System Utilities

System Utilities contains the following utilities that can be launched:

- Launch Diagnostics
- BIOS Update File Explorer
- Reboot System

## PXE boot

You can use the Preboot Execution Environment (PXE) option to boot and configure the networked systems, remotely.

**NOTE:** To access the PXE boot option, boot the system and then press F12. The system scans and displays the active networked systems.

# Installing and removing server components

## Safety instructions

- ⚠ WARNING:** Whenever you need to lift the system, get others to assist you. To avoid injury, do not attempt to lift the system by yourself.
- ⚠ WARNING:** Opening or removing the system cover while the system is powered on may expose you to a risk of electric shock.
- ⚠ CAUTION:** Do not operate the system without the cover for a duration exceeding five minutes.
- ⚠ CAUTION:** Many repairs may only be done by a certified service technician. You should only perform troubleshooting and simple repairs as authorized in your product documentation, or as directed by the online or telephone service and support team. Damage due to servicing that is not authorized by Dell is not covered by your warranty. Read and follow the safety instructions that are shipped with your product.
- ⚠ CAUTION:** Operating the system without the system cover can result in component damage.
- ℹ NOTE:** Dell recommends that you always use a static mat and static strap while working on components inside the system.
- ℹ NOTE:** To ensure proper operation and cooling, all bays in the system and system fans must be populated always with a component or with a blank.

## Before working inside your system

Follow the safety guidelines listed in Safety instructions.

- 1 Turn off the server, including any attached peripherals.
- 2 Disconnect the system from the electrical outlet and disconnect the peripherals.
- 3 If applicable, remove the system from the rack.  
For more information, see the Rack Installation placemat at <http://Dell.com/dssmanuals>.

## After working inside your system

Follow the safety guidelines listed in Safety instructions.

- 1 If applicable, install the system into the rack.  
For more information, see the Rack Installation placemat at <http://Dell.com/dssmanuals>.
- 2 Reconnect the peripherals and connect the system to the electrical outlet.
- 3 Turn on the system, including any attached peripherals.

## Recommended tools

You need the following tools to perform the removal and installation procedures:

- Key to the bezel lock  
The key is needed only if your system includes a bezel.
- Phillips #1 screwdriver

- Phillips #2 screwdriver
- 1/4 inch flat head screwdriver
- Torx #T20 screwdriver
- Torx #T30 screwdriver
- Torx #T6, #T8, #T10, and #T15 screwdrivers
- Wrist grounding strap

You need the following tools to assemble the cables for a DC power supply unit.

- AMP 90871-1 hand-crimping tool or equivalent
- Tyco Electronics 58433-3 or equivalent
- Wire-stripper pliers to remove insulation from size 10 AWG solid or stranded, insulated copper wire

**NOTE:** Use alpha wire part number 3080 or equivalent (65/30 stranding).

## System memory

This section provides information on memory population rules, general requirements and instructions on removing and installing memory modules.

### General memory module installation guidelines

**NOTE:** Memory configurations that fail to observe these guidelines can prevent your system from booting, stop responding during memory configuration, or operating with reduced memory.

The system supports Flexible Memory Configuration, enabling the system to be configured and run in any valid chipset architectural configuration. The following are the recommended guidelines for installing memory modules:

- RDIMMs and LRDIMMs must not be mixed.
- x4 and x8 DRAM based memory modules can be mixed. For more information, see the Mode-specific guidelines section.
- Both dual-rank and single-rank RDIMMs can be populated in each channel.
- Up to two LRDIMMs can be populated per channel regardless of rank count.
- If memory modules with different speeds are installed, they will operate at the speed of the slowest installed memory module(s) or slower depending on system DIMM configuration.
- Populate memory module sockets only if a processor is installed. For single-processor systems, sockets A1 to A8 are available. For dual-processor systems, sockets A1 to A8 and sockets B1 to B8 are available.
- Populate all the sockets with white release tabs first, followed by the black release tabs.
- When mixing memory modules with different capacities, populate the sockets with memory modules with highest capacity first. For example, if you want to mix 4 GB and 8 GB memory modules, populate 8 GB memory modules in the sockets with white release tabs and 4 GB memory modules in the sockets with black release tabs.
- In a dual-processor configuration, the memory configuration for each processor should be identical. For example, if you populate socket A1 for processor 1, then populate socket B1 for processor 2, and so on.
- Memory modules of different capacities can be mixed provided other memory population rules are followed (for example, 4 GB and 8 GB memory modules can be mixed).
- Mixing of more than two memory module capacities in a system is not supported.
- Populate six memory modules per processor (one DIMM per channel) at a time to maximize performance.

### Mode-specific guidelines

Six memory channels are allocated to each processor. The allowable configurations depend on the memory mode selected.

## Memory optimized (independent channel) mode

This mode supports Single Device Data Correction (SDDC) only for memory modules that use x4 device width. It does not impose any specific slot population requirements.

## Memory sparing

**NOTE:** To use memory sparing, this feature must be enabled in System Setup.

In this mode, one rank per channel is reserved as a spare. If persistent correctable errors are detected on a rank, the data from this rank is copied to the spare rank, and the failed rank is disabled.

With memory sparing enabled, the system memory available to the operating system is reduced by one rank per channel. For example, in a dual-processor configuration with sixteen 4 GB single-rank memory modules, the available system memory is:  $3/4$  (ranks/channel)  $\times$  16 (memory modules)  $\times$  4 GB = 48 GB, and not  $16$  (memory modules)  $\times$  4 GB = 64 GB.

**NOTE:** Memory sparing does not offer protection against a multi-bit uncorrectable error.

**NOTE:** Both Advanced ECC/Lockstep and Optimizer modes support memory sparing.

## Memory mirroring

Memory mirroring offers the strongest memory module reliability mode compared to all other modes, providing improved uncorrectable multi-bit failure protection. In a mirrored configuration, the total available system memory is one half of the total installed physical memory. Half of the installed memory is used to mirror the active memory modules. In the event of an uncorrectable error, the system switches over to the mirrored copy. This ensures SDDC and multi-bit protection.

The installation guidelines for memory modules are as follows:

- Memory modules must be identical in size, speed, and technology.
- Memory modules installed in memory module sockets with white release levers must be identical and the same rule applies for sockets with black release tabs. This ensures that identical memory modules are installed in matched pairs—for example, A1 with A2, A3 with A4, A5 with A6, and so on.

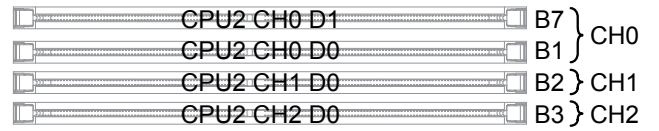
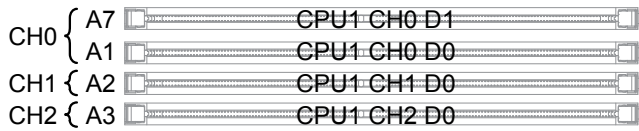
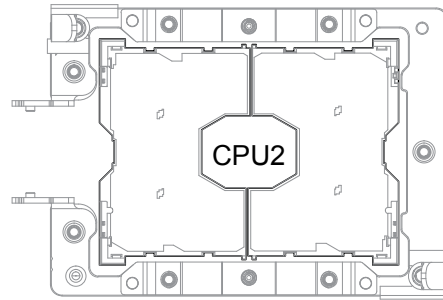
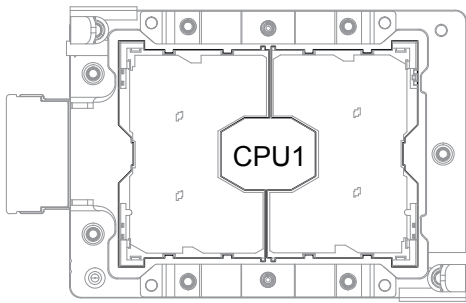
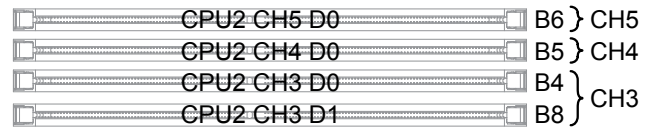
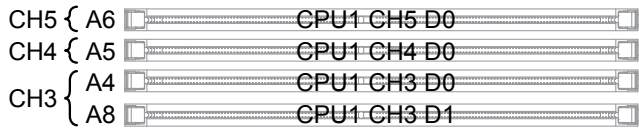

**Figure 5. Memory slot locations**

**Table 39. Memory configuration specifications**

Processor	Number of DIMMS	
	Maximum system capacity	Reliability, availability, and serviceability (RAS) features
Dual processor	16	16
Single processor	8	8

## Sample memory configurations

The following tables show sample memory configurations for two and four processor configurations that follow the appropriate memory guidelines.

**NOTE:** 1R, 2R, 4R, and 8R in the following tables indicate single, dual, quad, and octal rank DIMMs.

**Table 40. DIMM configuration specifications**

DIMM type	RDIMM	LRDIMM	3DS LRDIMM	NVDIMM
RDIMM				
LRDIMM				
3DS LRDIMM				
NVDIMM				

**Table 41. DIMM minimum population requirements**

DIMM type	CH0		CH1	CH2	CH3		CH4	CH5
	D0 (A1)	D1 (A7)	D0 (A2)	D0 (A3)	D0 (A4)	D1 (A8)	D0 (A5)	D0 (A6)
1LM DDR4	DRE	DO	DRE	DRE	DO	DO	DO	DO
1LM DDR4	DR	NR	DO	DO	DR	NR	DO	DO

- DR: DDR4 required.
- DRE: DDR4 required. But plugging in either one slot is allowed. Then the other 2 slots become DDR4 optional.
- DO: DDR4 optional.
- NR: NVDIMM required.
- NO: NVDIMM optional.

## Removing memory module

**CAUTION:** Many repairs may only be done by a certified service technician. You should only perform troubleshooting and simple repairs as authorized in your product documentation, or as directed by the online or telephone service and support team. Damage due to servicing that is not authorized by Dell is not covered by your warranty. Read and follow the safety instructions that are shipped with your product.

- 1 Ensure that you read the Safety instructions.
- 2 Complete the procedure listed in Before working inside your system.

**⚠ WARNING:** The memory modules are hot to touch for some time after the system has been powered down. Allow the memory modules to cool before handling them. Handle the memory modules by the card edges and avoid touching the components or metallic contacts on the memory module.

**⚠ CAUTION:** To ensure proper system cooling, memory module blanks must be installed in any memory socket that is not occupied. Remove memory module blanks only if you intend to install memory modules in those sockets.

1 Locate the appropriate memory module.

**⚠ CAUTION:** Handle each memory module by the card edges, ensuring not to touch the middle of the memory module or metallic contacts.

2 Press down on the two memory module locking latches. The memory module partially ejects.

3 Lift the memory module.

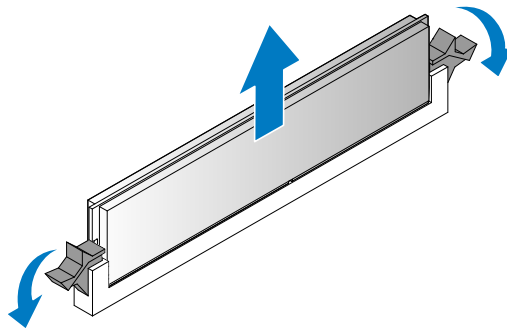

**Figure 6. Removing the memory module**

1 Install the new memory module.

2 Complete the procedure listed in After working inside your system.

## Installing memory module

1 Ensure that you read the Safety instructions.

2 Complete the procedure listed in Before working inside your system.

**⚠ WARNING:** Allow the memory modules to cool after you power off the system. Handle the memory modules by the card edges and avoid touching the components or metallic contacts on the memory module.

⚠ **CAUTION:** To ensure proper system cooling, memory module blanks must be installed in any memory socket that is not occupied. Remove memory module blanks only if you intend to install memory modules in those sockets.

⚠ **CAUTION:** To avoid damage, handle memory modules by the edges at all times.

- 1 Align the indentation on the memory module with the protrusion on the DIMM slot. Make sure they are aligned to avoid damaging the socket or the module.
- 2 Push the memory module firmly into the memory module slot.

📌 **NOTE:** If you are removing the memory module permanently, install a memory module blank.

The locking latches should automatically close over the edges of the memory module when fully inserted into the slot.

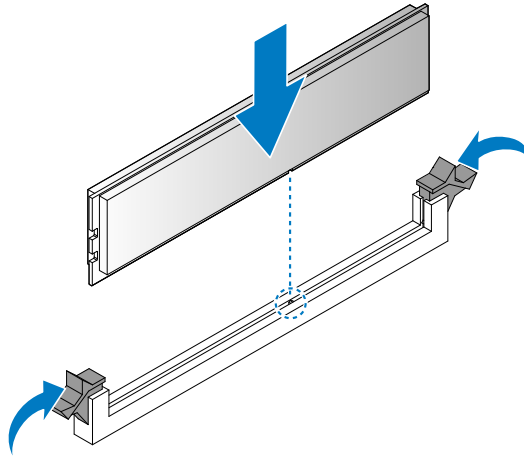

**Figure 7. Installing the memory module**

- 1 Complete the procedure listed in After working inside your system.
- 2 Press F2 to start System Setup, and check the System Memory setting. The **System Memory** value should reflect the newly installed memory.

If the value is incorrect, one or more of the memory modules may not be installed properly. Repeat Step 2 and Step 3 of this procedure, checking to ensure that the memory modules are firmly seated in their sockets.

- 3 Run the system memory test in the system diagnostics.

## Processor and heat sink

Use the following procedure when:

- Removing and installing the heat sink

- Installing the additional processor
- Replacing the processor

① **NOTE:** To ensure proper system cooling, you must install a processor blank in any empty processor socket.

## Removing heat sink

⚠ **CAUTION:** Never remove the heat sink from a processor unless you intend to remove the processor. The heat sink is necessary to maintain proper thermal conditions.

⚠ **WARNING:** The heat sink is hot to touch. Allow the heat sink to cool for some time after powering down the system.

- 1 Ensure that you read the Safety instructions.
- 2 Keep the #2 Phillips screwdriver handy.
- 3 Follow the procedure listed in the Before working inside your system section.
- 4 Before upgrading your system, download the latest system BIOS version from <http://dell.com/support> and follow the instructions included in the compressed download file to install the update on your system.

① **NOTE:** You can update the system BIOS using the Lifecycle Controller. For more information about Dell Lifecycle controller, see <http://dell.com/idracmanuals>.

- 5 Complete the procedure listed in Before working inside your system.

- 1 Disconnect the cable from the Mini PERC.
- 2 Remove the air shroud located between the heat sinks.

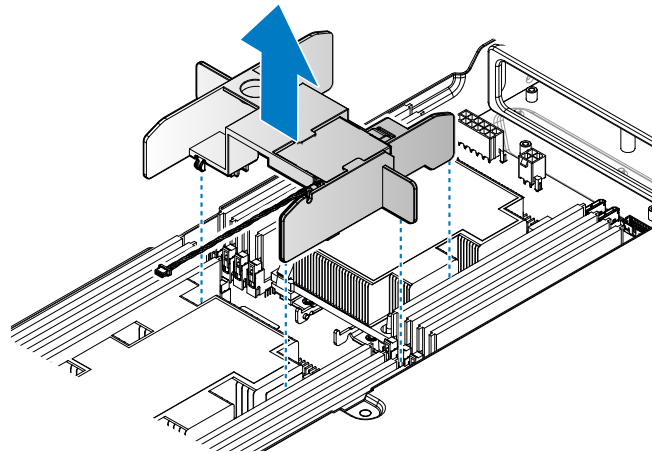
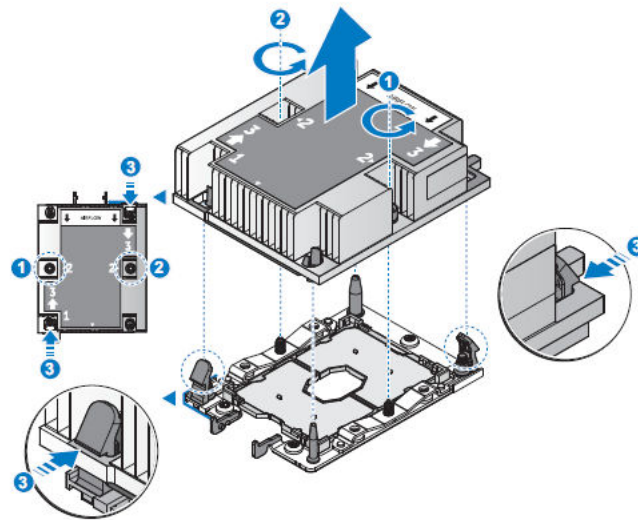

Figure 8. Removing the air shroud

- 3 In a sequential order, loosen the four screws securing the processor assembly.

- 4 Push the release latches to unlock the heat sink.
- 5 Remove the processor assembly and heat sink.



**Figure 9. Removing the heat sink**

- 1 Separate the heat sink and the processor.
- 2 Remove the processor.
- 3 Complete the procedure listed in After working inside your system.

## Removing processor

**NOTE:** If the new heat sink includes a thermal pad, it is not necessary to apply thermal grease to the top of the processor.

- 1 Ensure that you read the Safety instructions.
- 2 Before upgrading your system, download the latest system BIOS version from <http://dell.com/support> and follow the instructions included in the compressed download file to install the update on your system.

**NOTE:** You can update the system BIOS using the Lifecycle Controller. For more information about Dell Lifecycle controller, see <http://dell.com/idracmanuals>.

- 3 Complete the procedure listed in Before working inside your system.
- 4 Remove the heat sink.

- 1 Press the locking latches on all sides of the assembly and lift the heat sink out.
- 2 Remove the heat sink to expose the carrier and processor.

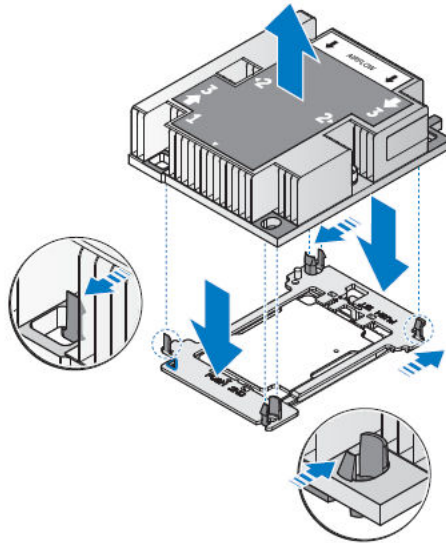

**Figure 10. Separating the processor and heat sink**

- 3 Release the latches to unlock the processor from the carrier. Allow some time (approximately 30 seconds) for the heat sink to loosen from the processor.
- 4 Remove the processor.

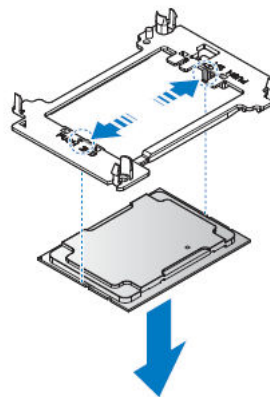

**Figure 11. Separating the processor and carrier**

- 1 Install the new processor.
- 2 Complete the procedure listed in After working inside your system.

## Installing processor

- 1 Ensure that you read the Safety instructions.
- 2 Before upgrading your system, download the latest system BIOS version from <http://dell.com/support> and follow the instructions included in the compressed download file to install the update on your system.

**NOTE:** You can update the system BIOS using the Dell Lifecycle Controller.

- 3 Complete the procedure listed in Before working inside your system.

- 1 Align the processor on the processor tray.

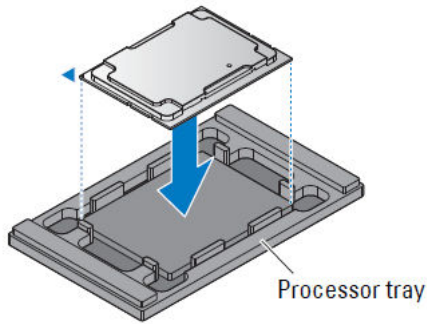

**Figure 12. Aligning the processor on the processor tray**

- 2 Align the triangular cutout of the socket and the indent on processor carrier with the gold triangle identifying pin of the processor.
- 3 Press the processor carrier to make sure the processor carrier is locked on the processor.

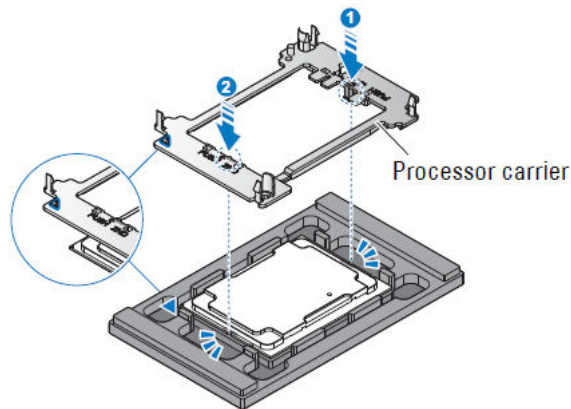

**Figure 13. Installing the processor carrier**

- 1 Install the heat sink.
- 2 Complete the procedure listed in After working inside your system.

## Installing heat sink

- 1 Ensure that you read the Safety instructions.
- 2 Keep the #2 Phillips screwdriver handy.
- 3 Before upgrading your system, download the latest system BIOS version from <http://dell.com/support> and follow the instructions included in the compressed download file to install the update on your system.

**NOTE:** You can update the system BIOS using the Dell Lifecycle Controller.

- 4 Complete the procedure listed in Before working inside your system.
- 5 Install the processor.

- 1 Remove the TIM protective film from the heat sink.

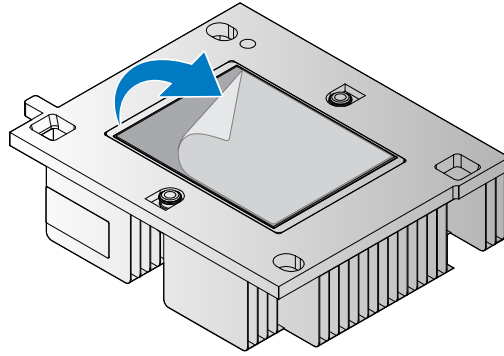

**Figure 14. Removing the TIM protective film**

- 2 Align the marked corner on the heat sink with the correlating location on the processor carrier.
- 3 Press the heat sink to lock it on the processor carrier.

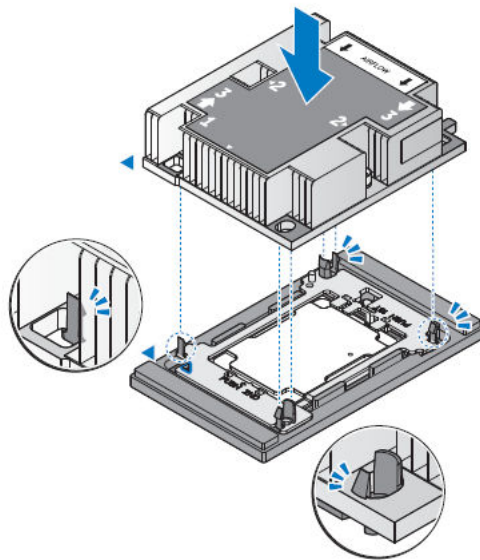

**Figure 15. Inserting the heat sink in a processor tray assembly**

- Once the heat sink locks onto the carrier, remove the heat sink and processor assembly from the processor tray.

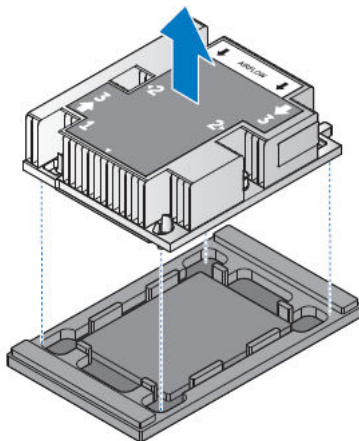

**Figure 16. Removing the processor assembly from the processor tray**

- Align the processor assembly on the server board, until it is seated firmly in place.
- In the marked order, tighten the retaining screws to secure the processor assembly.

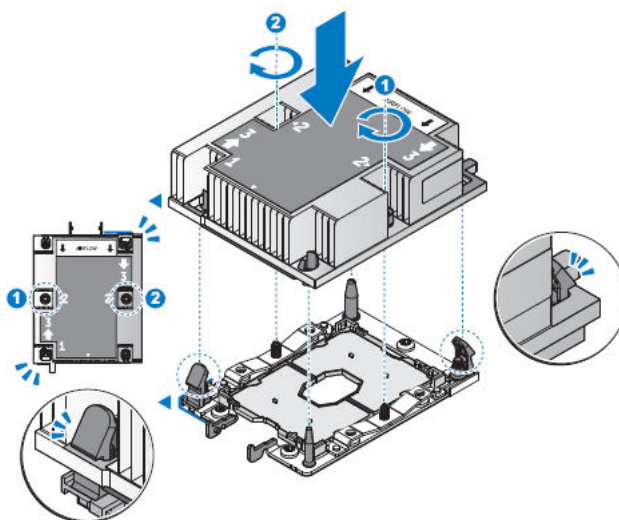
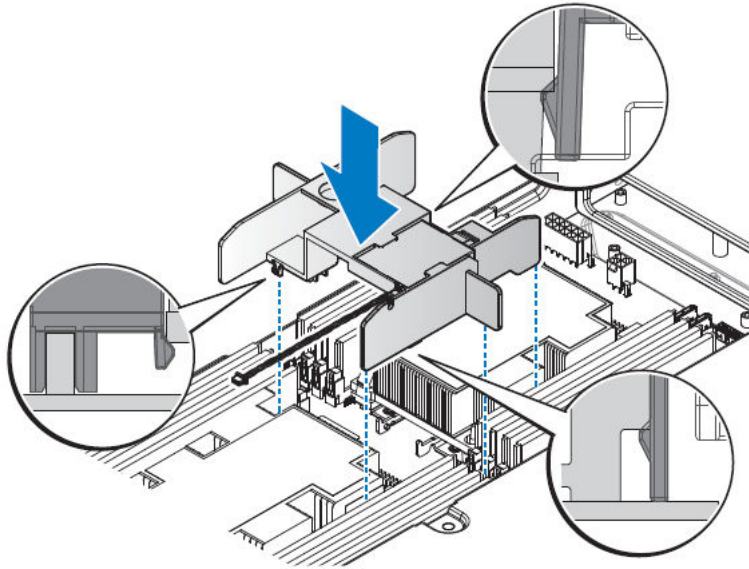

**Figure 17. Installing the processor assembly**

**Table 42. Assembly material**

Description	Description Quantity	Torque (lbs/inch)
CPU HSK screw	2	12 ± 0.2

- Install the air shroud between the heat sinks. Make sure the air shroud is locked in place.



**Figure 18. Installing the air shroud**

- 1 Complete the procedure listed in After working inside your system.
- 2 While booting, press F2 to start the System Setup and ensure that the processor information matches the new system configuration.
- 3 Run the system diagnostics to verify that the new processor operates correctly.

## Expansion card and riser

An expansion card in the server is an add-on card that can be inserted into an expansion slot on the server board or riser card to add enhanced functionality to the system through the expansion bus.

**NOTE:** A System Event Log (SEL) event is logged if an expansion card riser is unsupported or missing. It does not prevent your system from turning on and no BIOS POST message or F1/F2 pause is displayed.

## Expansion card installation guidelines

Depending on your system configuration, the following PCI Express (PCIe) generation 3 expansion cards are supported:

**Table 43. Expansion card guidelines**

Slot	Expansion card type	Riser	Processor connection	Link width	Slot width
1	DCS Mezz Card	DCS Mezz Riser	Processor 1	x8	x8
	Mini PERC Card	Mini PERC Riser			
	OCP Mezz Card	Transfer Board+Bridge Board			
	x8 PCIe/SATA M.2 Card	x8 PCIe/SATA M.2 Riser			
3	OCP Mezz Card	NA	Processor 1	x8	x8
4	PCIe RAID, PCIe NIC	PCIe Riser	Processor 1	x16	x16

Slot	Expansion card type	Riser	Processor connection	Link width	Slot width
5	x16 PCIe/SATA M.2 Card	3M Cable Riser	Processor 2	x16	x16
6	NPIO, PCIe RAID	NPIO Cable Rear Riser	Processor 2	x16	x16

**NOTE:** To use an expansion card on slots 5 and 6, processor 2 must be installed.

**NOTE:** Expansion card are not hot-swappable.

## Removing expansion card from slot 1

**CAUTION:** Many repairs may only be done by a certified service technician. You should only perform troubleshooting and simple repairs as authorized in your product documentation, or as directed by the online or telephone service and support team. Damage due to servicing that is not authorized by Dell is not covered by your warranty. Read and follow the safety instructions that are shipped with your product.

- 1 Follow the safety guidelines listed in the Safety instructions section.
- 2 Follow the procedure listed in the Before working inside your system section.

**NOTE:** To ensure proper system cooling, the riser blank must be installed in the appropriate riser slot. Remove the riser blank only if you are installing a riser.

## Installing expansion card into slot 1

**CAUTION:** Many repairs may only be done by a certified service technician. You should only perform troubleshooting and simple repairs as authorized in your product documentation, or as directed by the online or telephone service and support team. Damage due to servicing that is not authorized by Dell is not covered by your warranty. Read and follow the safety instructions that are shipped with your product.

- 1 Follow the safety guidelines listed in the Safety instructions section.
- 2 Follow the procedure listed in the Before working inside your system section.

## Removing expansion card from slot 3

**CAUTION:** Many repairs may only be done by a certified service technician. You should only perform troubleshooting and simple repairs as authorized in your product documentation, or as directed by the online or telephone service and support team. Damage due to servicing that is not authorized by Dell is not covered by your warranty. Read and follow the safety instructions that are shipped with your product.

- 1 Follow the safety guidelines listed in the Safety instructions section.
- 2 Follow the procedure listed in the Before working inside your system section.
- 3 Remove the expansion card from slot 1.

**NOTE:** To ensure proper system cooling, the riser blank must be installed in the appropriate riser slot. Remove the riser blank only if you are installing a riser.

## Installing expansion card into slot 3

**CAUTION:** Many repairs may only be done by a certified service technician. You should only perform troubleshooting and simple repairs as authorized in your product documentation, or as directed by the online or telephone service and support team. Damage due to servicing that is not authorized by Dell is not covered by your warranty. Read and follow the safety instructions that are shipped with your product.

- 1 Follow the safety guidelines listed in the Safety instructions section.
- 2 Follow the procedure listed in the Before working inside your system section.

## Removing expansion card from slot 4

**CAUTION:** Many repairs may only be done by a certified service technician. You should only perform troubleshooting and simple repairs as authorized in your product documentation, or as directed by the online or telephone service and support team. Damage due to servicing that is not authorized by Dell is not covered by your warranty. Read and follow the safety instructions that are shipped with your product.

- 1 Follow the safety guidelines listed in the Safety instructions section.
- 2 Follow the procedure listed in the Before working inside your system section.

**NOTE:** To ensure proper system cooling, the riser blank must be installed in the appropriate riser slot. Remove the riser blank only if you are installing a riser.

## Installing expansion card into slot 4

**CAUTION:** Many repairs may only be done by a certified service technician. You should only perform troubleshooting and simple repairs as authorized in your product documentation, or as directed by the online or telephone service and support team. Damage due to servicing that is not authorized by Dell is not covered by your warranty. Read and follow the safety instructions that are shipped with your product.

- 1 Follow the safety guidelines listed in the Safety instructions section.
- 2 Follow the procedure listed in the Before working inside your system section.

## Removing expansion card from slot 5

**CAUTION:** Many repairs may only be done by a certified service technician. You should only perform troubleshooting and simple repairs as authorized in your product documentation, or as directed by the online or telephone service and support team. Damage due to servicing that is not authorized by Dell is not covered by your warranty. Read and follow the safety instructions that are shipped with your product.

- 1 Follow the safety guidelines listed in the Safety instructions section.
- 2 Follow the procedure listed in the Before working inside your system section.

**NOTE:** To ensure proper system cooling, the riser blank must be installed in the appropriate riser slot. Remove the riser blank only if you are installing a riser.

## Installing expansion card into slot 5

**CAUTION:** Many repairs may only be done by a certified service technician. You should only perform troubleshooting and simple repairs as authorized in your product documentation, or as directed by the online or telephone service and support team. Damage due to servicing that is not authorized by Dell is not covered by your warranty. Read and follow the safety instructions that are shipped with your product.

- 1 Follow the safety guidelines listed in the Safety instructions section.
- 2 Follow the procedure listed in the Before working inside your system section.

## Removing expansion card from slot 6

**CAUTION:** Many repairs may only be done by a certified service technician. You should only perform troubleshooting and simple repairs as authorized in your product documentation, or as directed by the online or telephone service and support team. Damage due to servicing that is not authorized by Dell is not covered by your warranty. Read and follow the safety instructions that are shipped with your product.

- 1 Follow the safety guidelines listed in the Safety instructions section.
- 2 Follow the procedure listed in the Before working inside your system section.

**NOTE:** To ensure proper system cooling, the riser blank must be installed in the appropriate riser slot. Remove the riser blank only if you are installing a riser.

## Installing expansion card into slot 6

**CAUTION:** Many repairs may only be done by a certified service technician. You should only perform troubleshooting and simple repairs as authorized in your product documentation, or as directed by the online or telephone service and support team. Damage due to servicing that is not authorized by Dell is not covered by your warranty. Read and follow the safety instructions that are shipped with your product.

- 1 Follow the safety guidelines listed in the Safety instructions section.
- 2 Follow the procedure listed in the Before working inside your system section.

## System battery

The system battery is used for system functions like powering the real-time clock and storing the computer's BIOS settings.

## Removing system battery

**WARNING:** There is a danger of a new battery exploding if it is incorrectly installed. Replace the battery only with the same or equivalent type recommended by the manufacturer. See your safety information for additional details.

**CAUTION:** Many repairs may only be done by a certified service technician. You should only perform troubleshooting and simple repairs as authorized in your product documentation, or as directed by the online or telephone service and support team. Damage due to servicing that is not authorized by Dell is not covered by your warranty. Read and follow the safety instructions that came with the product.

**NOTE:** Battery is a Field Replaceable Unit (FRU). Only Dell certified service technicians must remove or install system battery.

- 1 Follow the safety guidelines listed in the Safety instructions section.
- 2 Complete the procedure listed in Before working inside your system.

- 3 Remove the PCIe card.
- 1 Locate the battery socket, see Jumpers and connectors.

**CAUTION:** To avoid damage to the battery connector, you must firmly support the connector while installing or removing a battery.

- 2 To eject the battery, press firmly on the edge of the positive side of the battery in the direction of the arrow as shown in the figure.

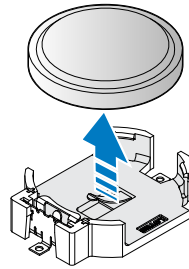

**Figure 19. Removing the system battery**

- 1 Install the PCIe card.
- 2 Complete the procedure listed in After working inside your system.
- 3 While booting, press F2 to start the System Setup and ensure the battery is operating properly.
- 4 Enter the correct time and date in the System Setup **Time** and **Date** fields.
- 5 Exit the System Setup.

## Installing system battery

**WARNING:** There is a danger of a new battery exploding if it is incorrectly installed. Replace the battery only with the same or equivalent type recommended by the manufacturer. See your safety information for additional details.

**CAUTION:** Many repairs may only be done by a certified service technician. You should only perform troubleshooting and simple repairs as authorized in your product documentation, or as directed by the online or telephone service and support team. Damage due to servicing that is not authorized by Dell is not covered by your warranty. Read and follow the safety instructions that came with the product.

**NOTE:** Battery is a Field Replaceable Unit (FRU). Only Dell certified service technicians must remove or install system battery.

- 1 Ensure that you read the Safety instructions.
  - 2 Complete the procedure listed in Before working inside your system.
  - 3 Remove the PCIe card.
- 1 To install a new server battery, hold the battery with the positive facing up and slide it under the securing tabs.
  - 2 Press the battery into the connector until it snaps into place.

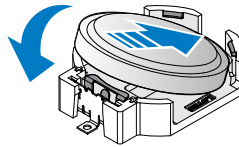

**Figure 20. Installing the system battery**

- 1 Install the PCIe card.
- 2 Complete the procedure listed in After working inside your system.
- 3 While booting, press F2 to start the System Setup and ensure the battery is operating properly.
- 4 Enter the correct time and date in the System Setup **Time** and **Date** fields.
- 5 Exit the System Setup.

## Hard drive

For more information on hard drives, see the 512e and 4Kn Disk Formats whitepaper and 4K Sector HDD FAQ document at <http://Dell.com/dssmanuals>.

All hard drives are connected to the server board through the hard drive backplane. Hard drives are supplied in hot swappable hard drive carriers that fit in the hard drive slots.

**CAUTION:** Before attempting to remove or install a hard drive while the system is running, see the documentation for the storage controller card to ensure that the host adapter is configured correctly to support hot swappable hard drive removal and insertion.

**CAUTION:** Do not turn off or restart your system while the hard drive is being formatted. Doing so can cause a hard drive failure.

Use only hard drives that have been tested and approved for use with the hard drive backplane.

When you format a hard drive, allow enough time for the formatting to be complete. Be aware that high-capacity hard drives can take a long time to format.

## Removing 2.5-inch hard drive from the rear bay

- 1 Follow the safety guidelines listed in the Safety instructions section.
- 2 Complete the procedure listed in Before working inside your system.

**⚠ CAUTION: To maintain proper system cooling, all empty hard drive slots must have hard drive blanks installed.**

- 1 Loosen the thumb screw.
- 2 Slide the HDD assembly out and pull up to remove.

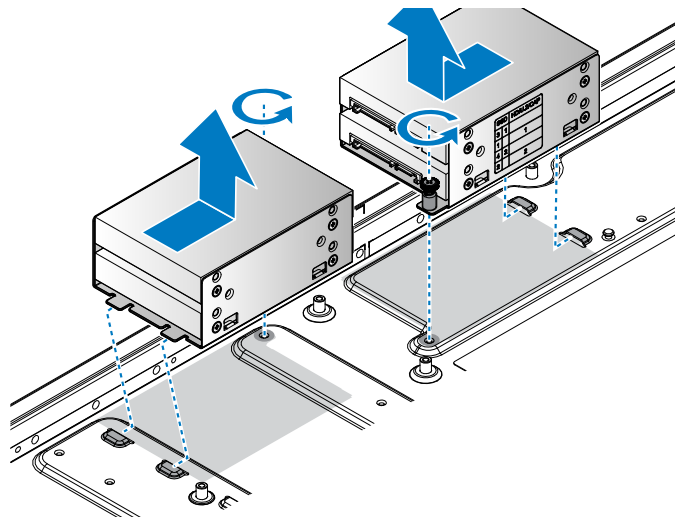

**Figure 21. Removing the 2.5-inch HDD assembly**

- 3 Remove the screws securing the HDD to the carrier.
- 4 Remove the HDD from the carrier.

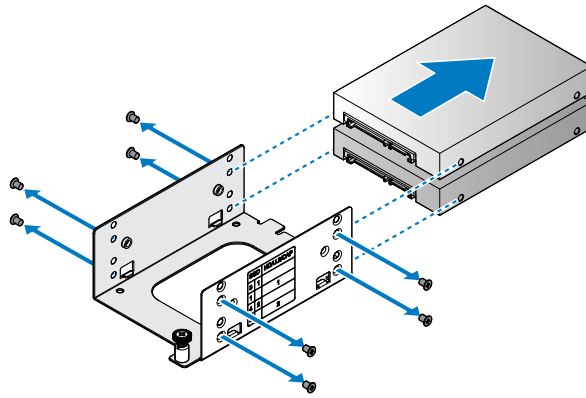
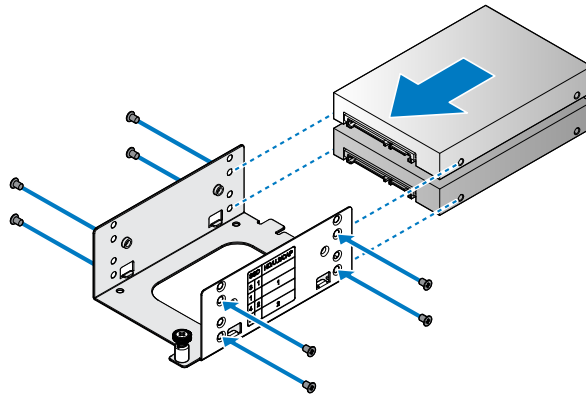

**Figure 22. Removing the 2.5-inch HDD**

- 1 Install a 2.5-inch HDD into a rear bay.
- 2 Complete the procedure listed in After working inside your system.

## Installing 2.5-inch hard drive into the rear bay

- 1 Follow the safety guidelines listed in the Safety instructions section.
  - 2 Complete the procedure listed in Before working inside your system.
- 1 Align the HDD with the HDD carrier. Make sure the connectors are facing the front. Make sure the connectors are positioned as demonstrated in the following illustration.
  - 2 Secure the HDD with the provided screws.

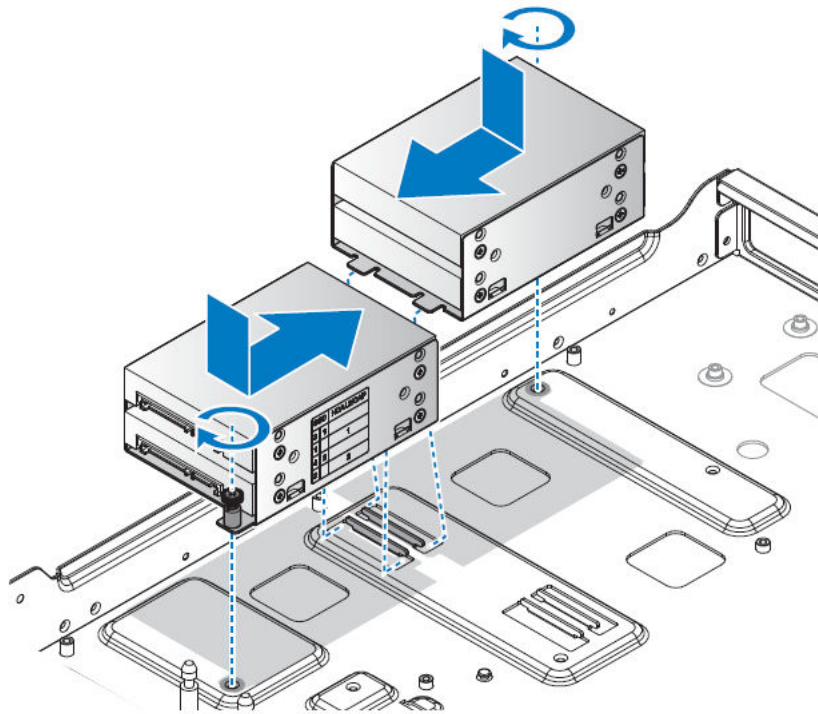

**Figure 23. Installing the 2.5-inch HDD**

**Table 44. Assembly material**

Description	Quantity	Torque (lbs/inch)
M3 screw	4 (1 per HDD)	6 ± 0.2

- 3 Align the HDD assembly in the chassis.
- 4 Install the HDD assembly and slide it to seat properly.
- 5 Secure with the thumb screw.



**Figure 24. Installing the 2.5-inch HDD assembly**

- 1 Complete the procedure listed in After working inside your system.

## Removing 3.5-inch hard drive from a tray

- 1 Follow the safety guidelines listed in the Safety instructions section.
- 2 Complete the procedure listed in Before working inside your system.

**⚠ CAUTION: To maintain proper system cooling, all empty hard drive slots must have hard drive blanks installed.**

- 1 Grasp the tray handle with one hand, and use your thumb to push the plunger up to release the HDD tray.
- 2 Continue to hold the plunger and use the tray handle to pull the tray out from the chassis.

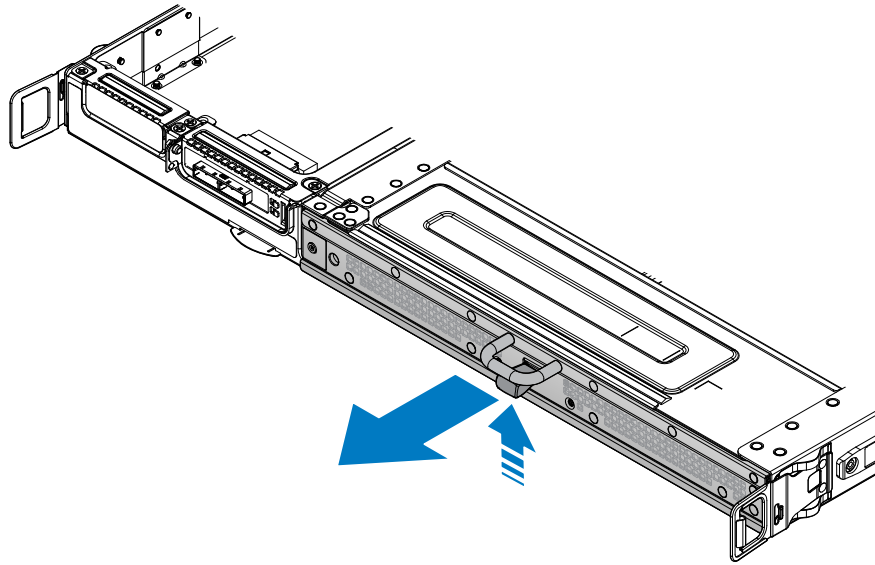

**Figure 25. Releasing the HDD tray**

- 3 Remove the HDD tray from the server.

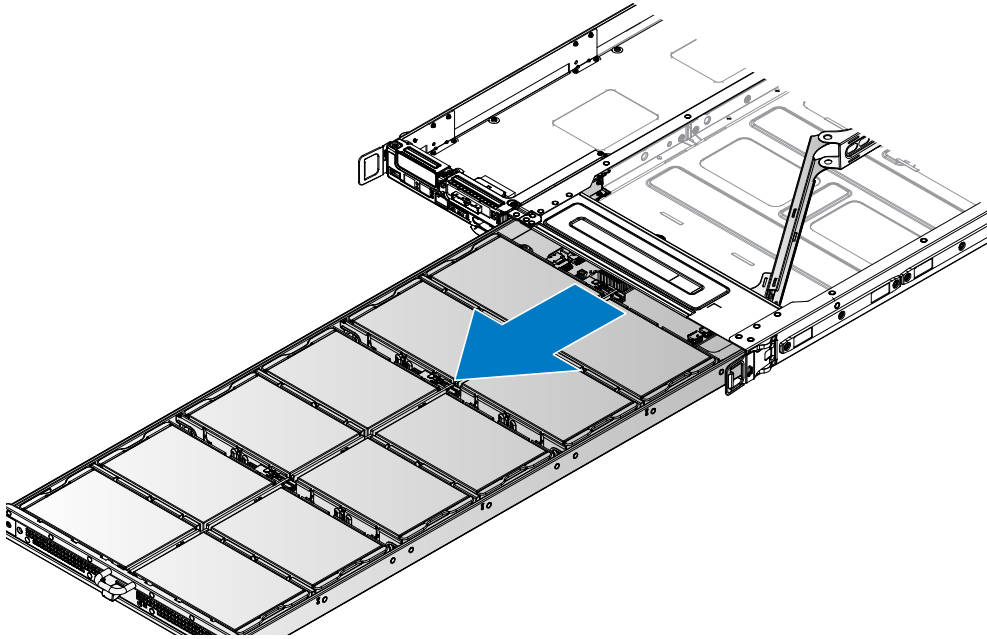

**Figure 26. Removing the HDD tray**

- 4 Grasp the locking lever on the HDD carrier.
- 5 Rotate the locking lever to a 90° angle. The HDD disengages from the backplane.

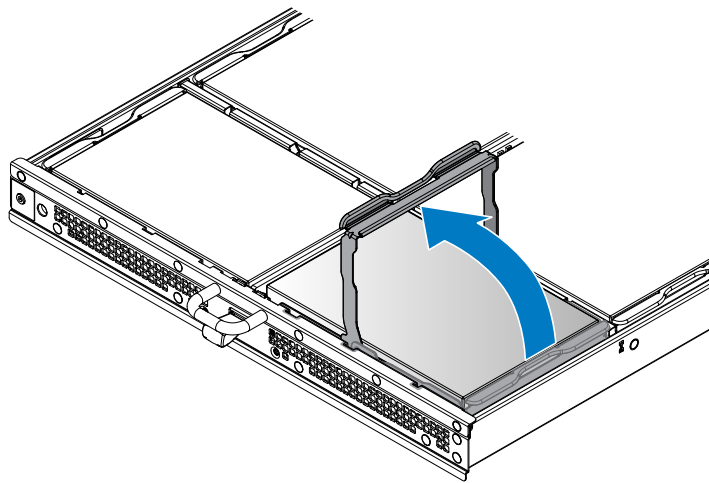

**Figure 27. Unlocking the 3.5-inch HDD assembly**

- 6 Lift the HDD assembly up to remove from the chassis.
- 7 Remove the screws securing the HDD to the HDD carrier.
- 8 Lift up the HDD to separate it from the HDD carrier.

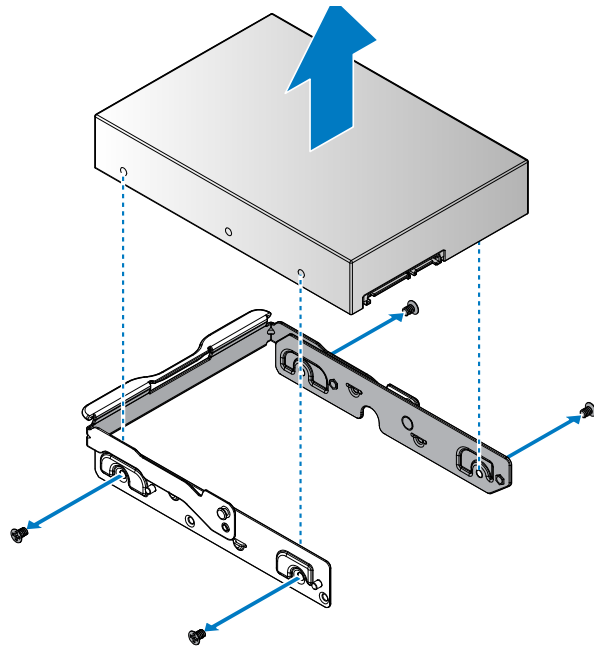
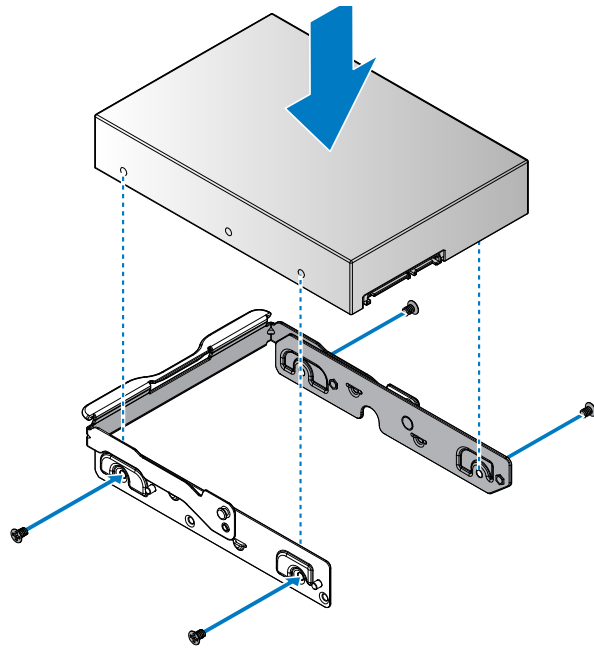

**Figure 28. Removing the 3.5-inch HDD**

- 1 Install the 3.5-inch HDD into a tray.
- 2 Complete the procedure listed in After working inside your system.

## Installing 3.5-inch hard drive into a tray

- 1 Follow the safety guidelines listed in the Safety instructions section.
  - 2 Complete the procedure listed in Before working inside your system.
- 1 Align the HDD in the HDD carrier. Make sure the screw holes on the HDD are aligned with the screw holes on the HDD carrier.
  - 2 Place the HDD in the HDD carrier and secure with the provided screws.

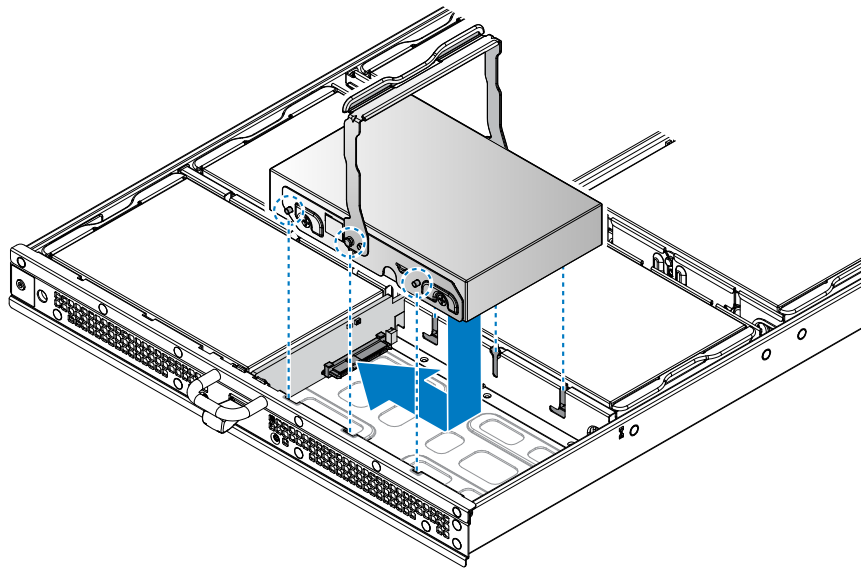

**Figure 29. Installing the 3.5-inch HDD**

**Table 45. Assembly material**

Description	Quantity	Torque (lbs/inch)
#6-32 screw	4 (1 per HDD)	6 ± 0.2

- 3 Grasp the locking lever on the HDD carrier and pull up to a 90° angle.
- 4 Lower the HDD assembly in place and align the studs with the slots on the partition walls.



**Figure 30. Installing the 3.5-inch HDD assembly**

- 5 Lower the locking lever until it touches the stop point on the HDD carrier.

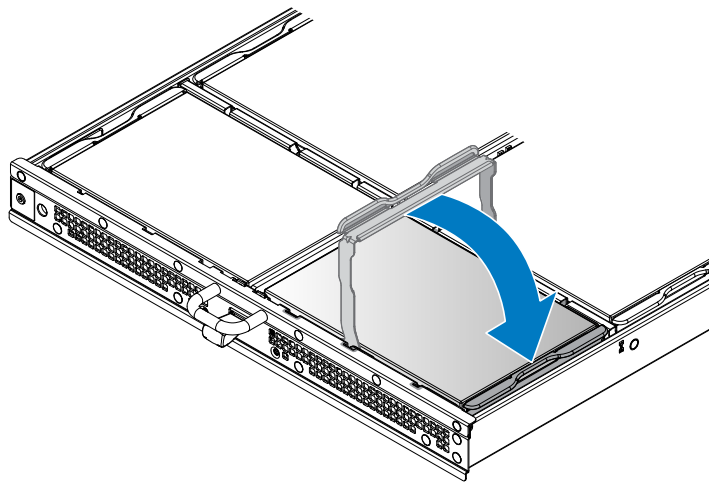

**Figure 31. Installing the 3.5-inch HDD assembly**

- 6 Install the HDDs on the HDD tray.
- 7 Push the HDD tray in until it is fully seated in the chassis.  
The HDD tray locks in place after it is properly seated.

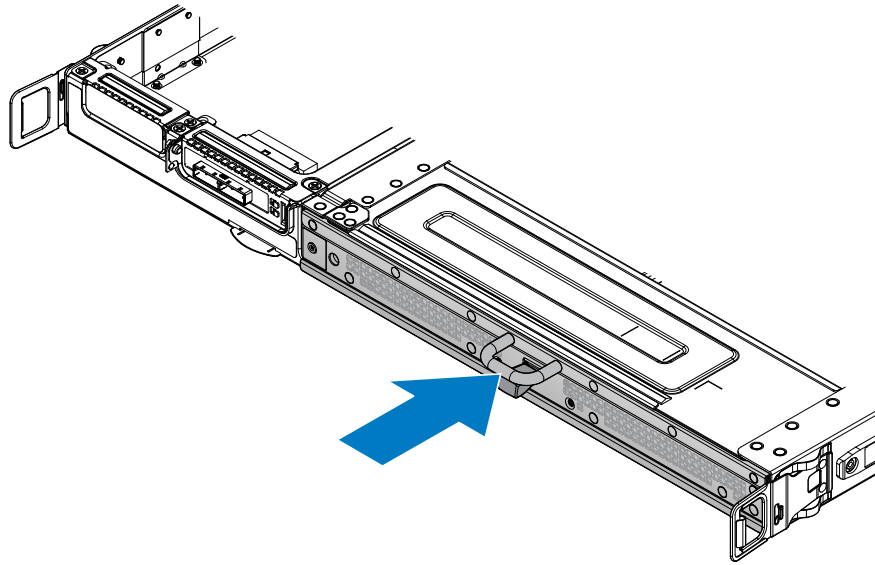

**Figure 32. Installing the HDD tray**

- 1 Complete the procedure listed in After working inside your system.

## Removing 2.5-inch hard drive from a tray

- 1 Follow the safety guidelines listed in the Safety instructions section.
- 2 Complete the procedure listed in Before working inside your system.

**⚠ CAUTION: To maintain proper system cooling, all empty hard drive slots must have hard drive blanks installed.**

- 1 Grasp the tray handle with one hand, and use your thumb to push the plunger up to release the HDD tray.
- 2 Continue to hold the plunger and use the tray handle to pull the tray out from the chassis.
- 3 Remove the HDD tray from the server.
- 4 Grasp the locking lever on the HDD carrier.
- 5 Rotate the locking lever to a 90° angle. The HDD disengages from the backplane.

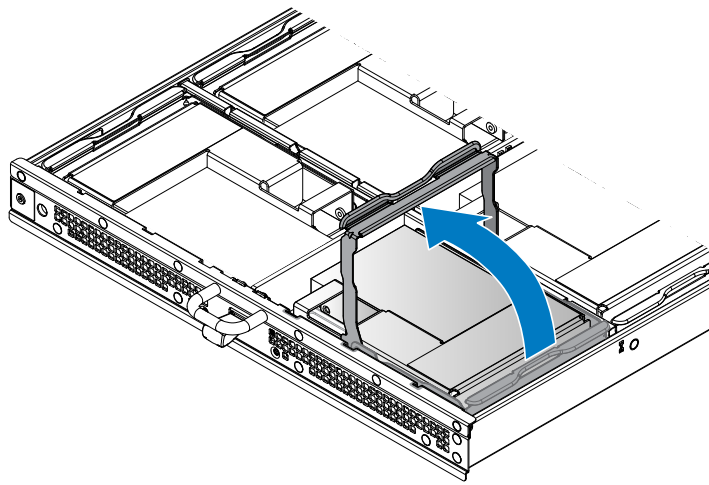

**Figure 33. Unlocking the 2.5-inch HDD assembly**

- 6 Lift the HDD assembly up to remove from the chassis.

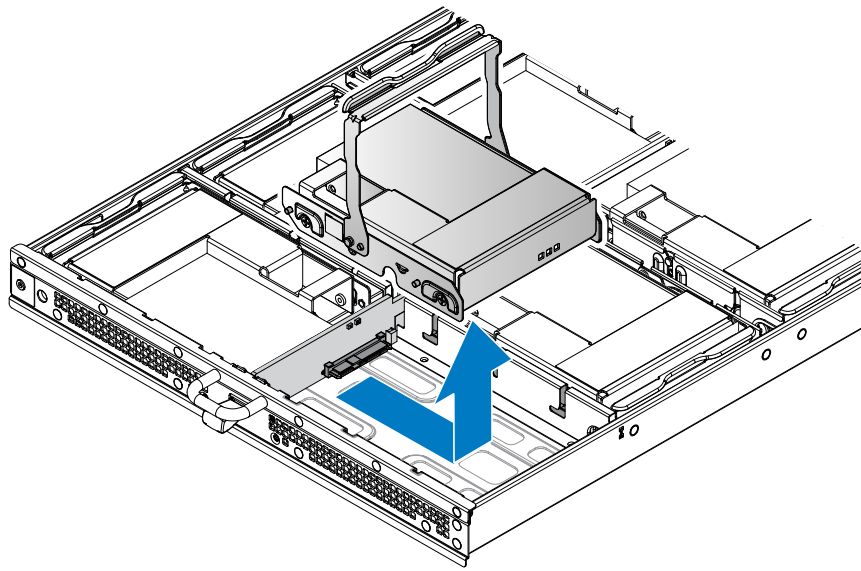

**Figure 34. Removing the 2.5-inch HDD assembly**

- 7 Remove the screws securing the HDD assembly to the HDD carrier.
- 8 Lift up the HDD assembly to separate it from the HDD carrier.

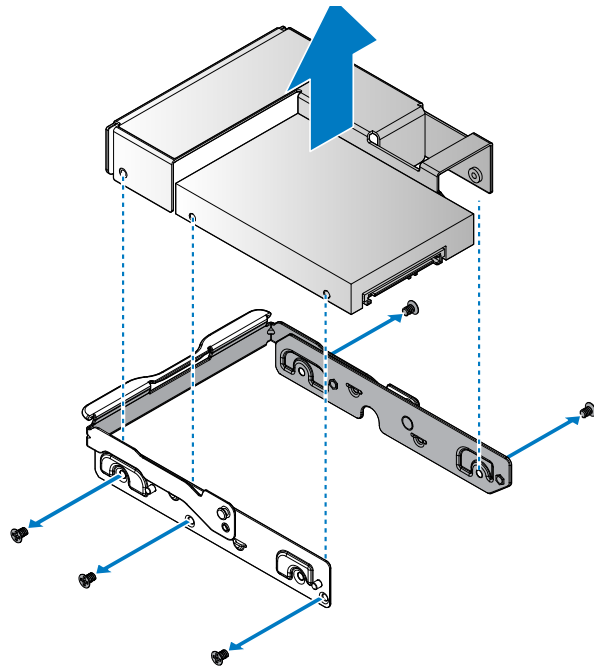

**Figure 35. Removing the 2.5-inch HDD assembly from the HDD carrier**

- 9 Remove the screws securing the HDD to the adapter bracket.
- 10 Remove the HDD from the adapter bracket.

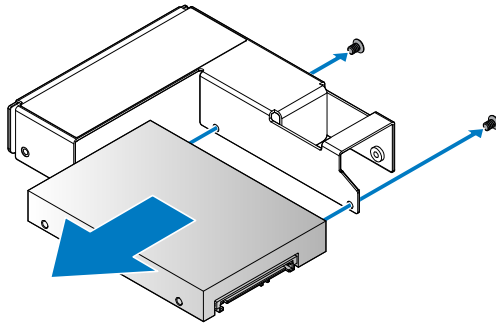
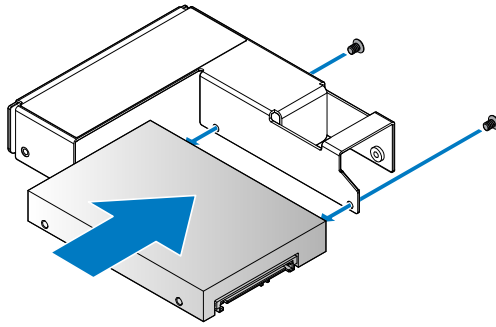

**Figure 36. Removing the 2.5-inch HDD**

- 1 Install the 2.5-inch HDD into a tray.
- 2 Complete the procedure listed in After working inside your system.

## Installing 2.5-inch hard drive into a tray

- 1 Follow the safety guidelines listed in the Safety instructions section.
  - 2 Complete the procedure listed in Before working inside your system.
- 1 Align the HDD in the adapter bracket. Make sure the screw holes on the HDD are aligned with the screw holes on the adapter bracket.
  - 2 Secure the HDD and adapter bracket with the provided screws.

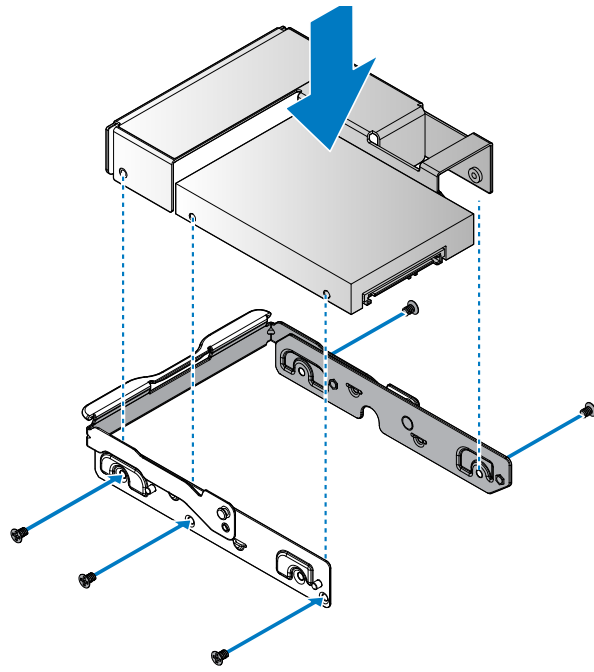

**Figure 37. Installing the 2.5-inch HDD**

**Table 46. Assembly material**

Description	Quantity	Torque (lbs/inch)
M3 screw	2 (1 per HDD)	6 ± 0.2

- 3 Align the HDD assembly in the HDD carrier. Make sure the screw holes on the HDD assembly are aligned with the screw holes on the HDD carrier.
- 4 Place the HDD assembly in the HDD carrier and secure with the provided screws.

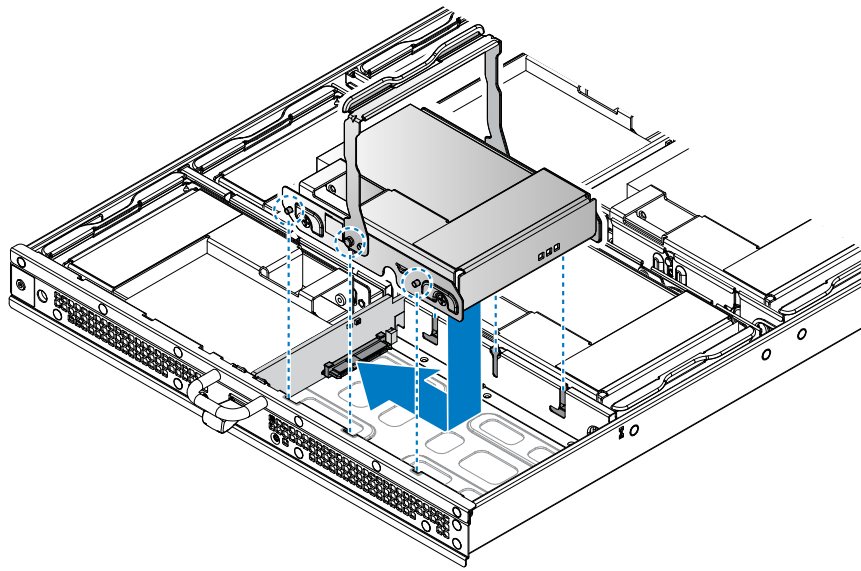

**Figure 38. Installing the 2.5-inch HDD assembly to the HDD carrier**

**Table 47. Assembly material**

Description	Quantity	Torque (lbs/inch)
M3 screw	5 (1 per HDD)	6 ± 0.2

- 5 Grasp the locking lever on the HDD carrier and pull up to a 90° angle.
- 6 Lower the HDD assembly in place and align the studs with the slots on the partition walls.



**Figure 39. Installing the 2.5-inch HDD assembly**

- 7 Lower the locking lever until it touches the stop point on the HDD carrier.

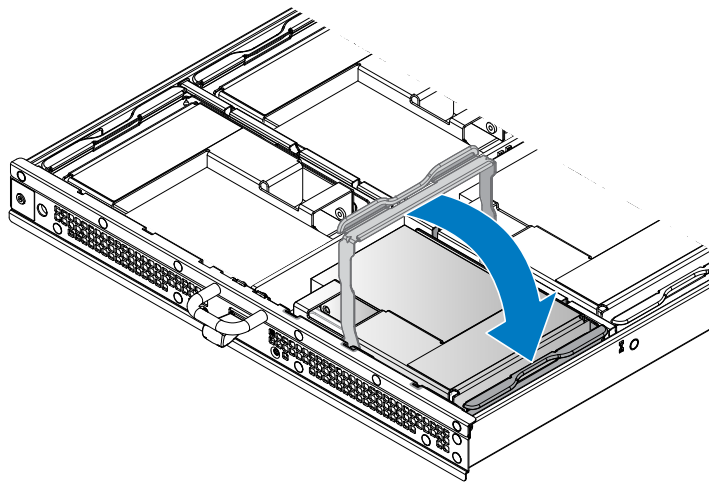

**Figure 40. Installing the 2.5-inch HDD assembly**

- 8 Install the HDDs on the HDD tray.
- 9 Push the HDD tray in until it is fully seated in the chassis.  
The HDD tray locks in place after it is properly seated.

## Server board

A server board (also known as the motherboard) is the main printed circuit board in the system with different connectors used to connect different components or peripherals of the system. A server board provides the electrical connections to the components in the system to communicate.

## Removing server board

**CAUTION:** Do not attempt to remove the TPM plug-in module from the server board. Once the TPM plug-in module is installed, it is cryptographically bound to that specific server board. Any attempt to remove an installed TPM plug-in module breaks the cryptographic binding, and it cannot be reinstalled or installed on another server board.

- 1 Follow the safety guidelines listed in the Safety instructions section.
- 2 Complete the procedure listed in Before working inside your system.
- 3 Remove the PCIe card.
- 4 Remove the mezzanine card.
- 5 Remove the OCP card.
- 6 Remove the expansion riser on slot 5.

- 7 Remove memory modules.
- 8 Remove heat sinks and processors.
- 1 Press the release latches to release the air duct.
- 2 Remove the air duct.

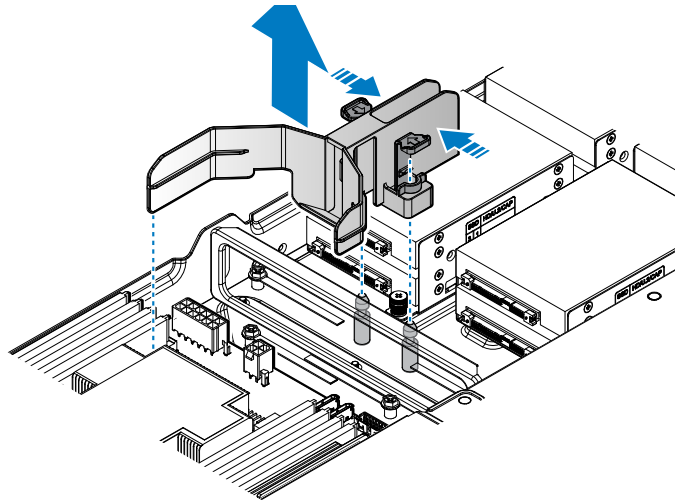

**Figure 41. Removing the air duct**

- 3 Disconnect all cables from the server board.
- 4 Remove the securing screws from the server board.
- 5 Disconnect the cable clip rings.

**NOTE:** The location of cable clips may differ depending on the models.

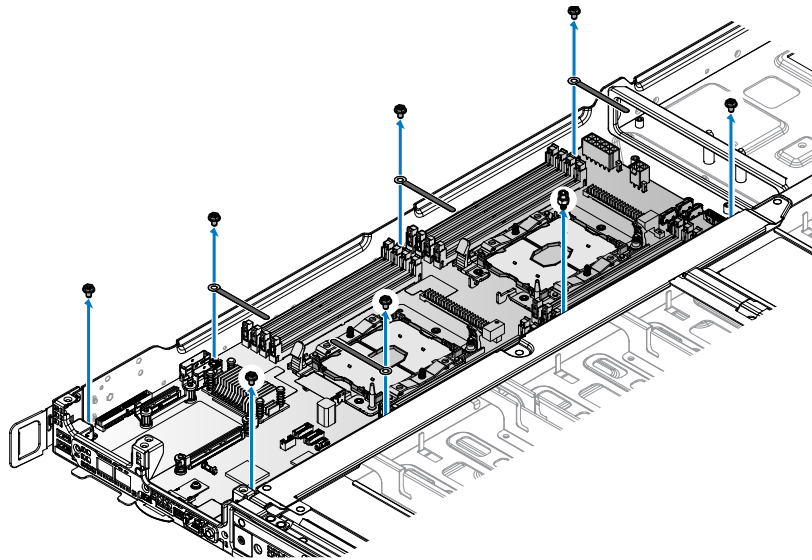

**Figure 42. Removing server board securing screws**

- 6 Grasp the back of the server board and tilt upward. Do not lift the back of the server board completely to prevent damage to the components and I/O ports on the front.
- ⚠ CAUTION: Do not lift the server board by holding a memory module slot, any other connector, or component.**
- 7 Pull the server board back to release the I/O ports from the chassis, and lift the server board out to remove.
- 8 Place the server board in an antistatic bag.

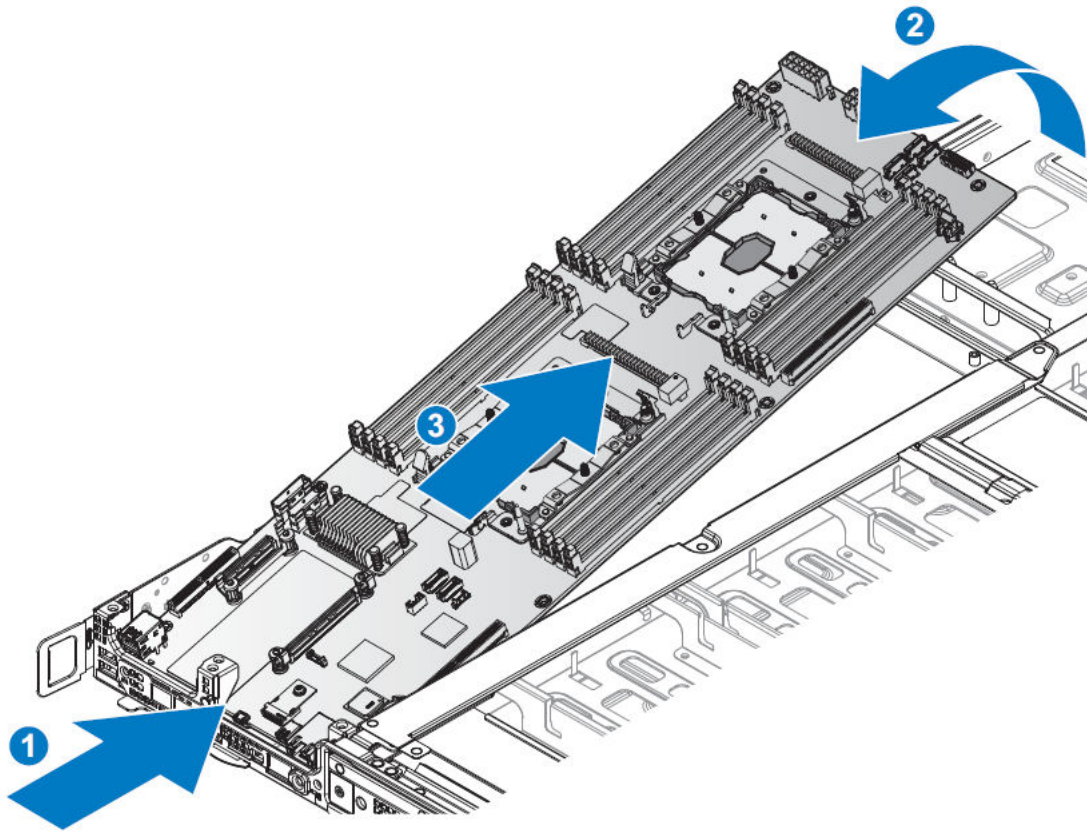

**Figure 43. Removing the server board**

- 1 Install the server board.
- 2 Complete the procedure listed in After working inside your system.

## Installing server board

- 1 Follow the safety guidelines listed in the Safety instructions section.
- 2 Complete the procedure listed in Before working inside your system.
- 1 Remove the new server board from its antistatic bag and hold by the edges.
- 2 If removed, install the Trusted Platform Module (TPM). For information about how to install the TPM, see the Installing trusted platform module section. For more information about the TPM, see the Trusted platform module section.

**NOTE:** The TPM plug-in module once installed is attached to the server board and cannot be removed. In the event of a server board replacement, a TPM plug-in module is provided along with the server board for all systems that have a TPM.

- 3 Align the I/O ports on the server board with the front of the server.
- 4 Angle the server board into the I/O ports. Make sure the ports on the server board are seated correctly in the chassis.
- 5 Gently lower the server board in the chassis.
- 6 After the server board is in place, slide it towards the grill until the server board is seated in place and the screw holes (server board and chassis) are aligned.

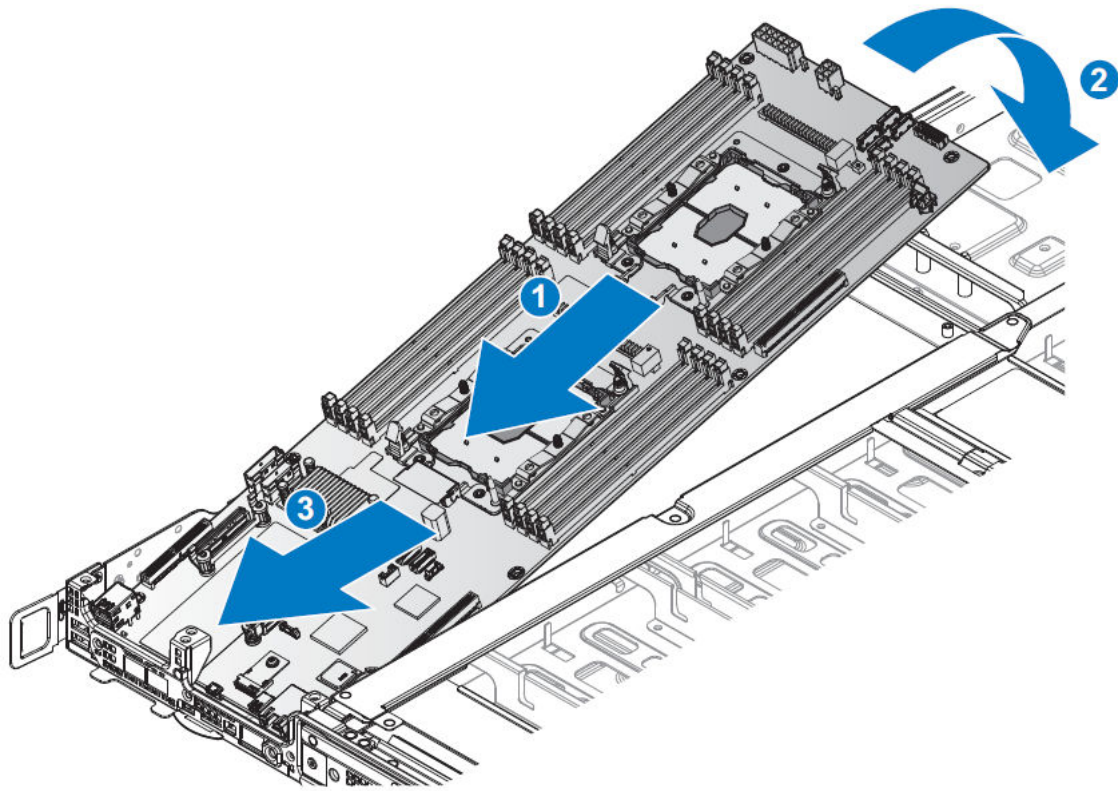

**Figure 44. Installing the server board**

- 7 Secure the two marked locations with the provided shoulder screws.
- 8 Insert the cable clips in the marked location and secure with the provided screws.
- 9 Attach the remaining screws to secure the server board to the chassis.
- 10 Connect all cables to the server board.

**NOTE:** The location of cable clips may differ depend on the models.

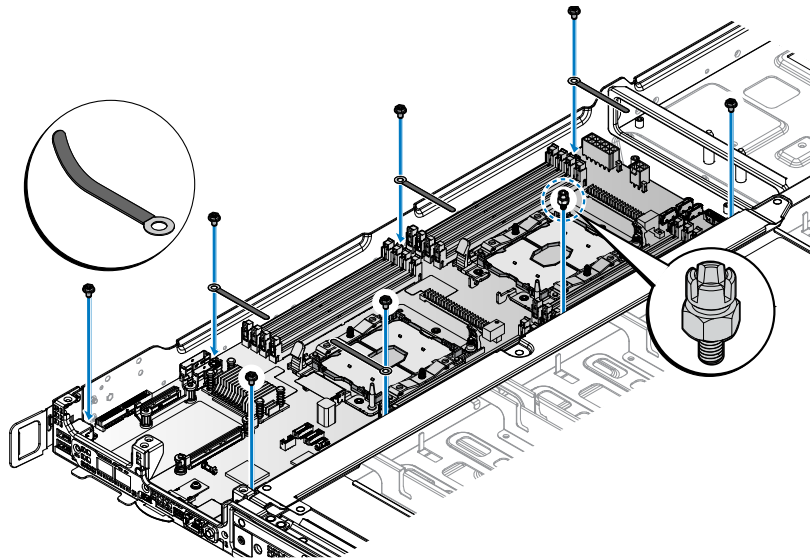
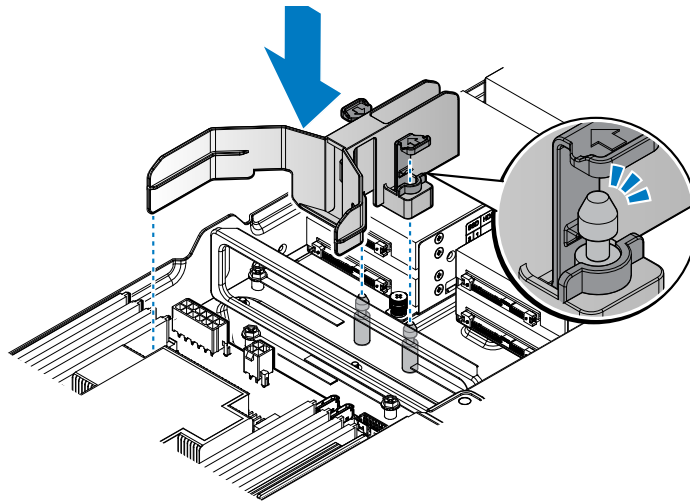

**Figure 45. Securing the server board**

**Table 48. Assembly material**

Description	Quantity	Torque (lbs/inch)
M3 screw	7	6 ± 0.2
Special screw (A)	1	6 ± 0.2

- 11 Align the air duct with the standoffs on the chassis.
- 12 Press down the air duct. Make sure the air duct is fully seated on the chassis and locked with the standoffs.



**Figure 46. Installing the air duct**

- 1 Install heat sinks and processors.
- 2 Install memory modules.
- 3 Install the expansion riser to slot 5.
- 4 Install the OCP card.
- 5 Install the mezzanine card.
- 6 Install the PCIe card.
- 7 Complete the procedure listed in After working inside your system.

## Trusted platform module

Trusted Platform Module (TPM) is a dedicated microprocessor designed to secure hardware by integrating cryptographic keys into devices. Software can use a Trusted Platform Module to authenticate hardware devices. Because each TPM chip has a unique and secret RSA key which is embedded during the manufacture of the TPM, and it is capable of performing platform authentication operation.

**⚠ CAUTION: Do not attempt to remove the Trusted Platform Module (TPM) from the server board. After the TPM is installed, it is cryptographically bound to that specific server board. Any attempt to remove an installed TPM breaks the cryptographic binding, and it cannot be re-installed or installed on another server board.**

# Installing trusted platform module

**CAUTION:** Do not attempt to remove the Trusted Platform Module (TPM) from the server board. Once the TPM is installed, it is cryptographically bound to that specific server board. Any attempt to remove an installed TPM breaks the cryptographic binding, and it cannot be re-installed or installed on another server board.

**NOTE:** This is a Field Replaceable Unit (FRU). Removal and installation procedures should be performed only by Dell certified service technicians.

- 1 Follow the safety guidelines listed in the Safety instructions section.
- 2 Complete the procedure listed in Before working inside your system.
- 3 Remove the PCIe card.
- 1 Align the trust platform module into the server board connector and insert it.

**NOTE:** To locate the TPM connector on the server board, see the server board connectors section.

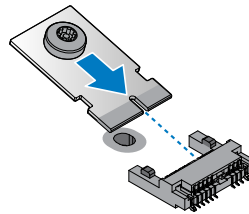

**Figure 47. Inserting the trust platform module**

- 2 Flip down the TPM. Make sure it is secured on the server board.

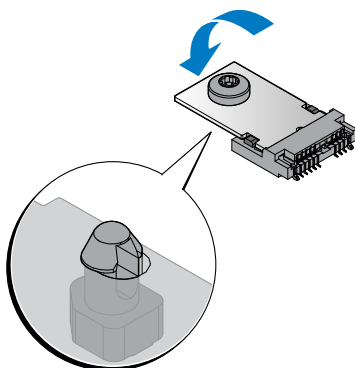

**Figure 48. Securing the TPM**

- 1 Install the PCIe card.
- 2 Complete the procedure listed in After working inside your system.

## Initializing TPM for BitLocker users

- For more information, see <http://technet.microsoft.com/en-us/library/cc753140.aspx>  
The **TPM Status** changes to **Enabled, Activated**.

## Initializing TPM for TXT users

- 1 While booting your system, press F2 to enter System Setup.
- 2 On the **System Setup Main Menu** screen, click **System BIOS > System Security Settings**.
- 3 From the **TPM Security** option, select **On with Pre-boot Measurements**.
- 4 From the **TPM Command** option, select **Activate**.
- 5 Save the settings.
- 6 Restart your system.
- 7 Enter **System Setup** again.
- 8 On the **System Setup Main Menu** screen, click **System BIOS > System Security Settings**.
- 9 From the **Intel TXT** option, select **On**.

# Restoring the Service Tag by using the Easy Restore feature

By using the Easy Restore feature, you can restore your Service Tag, license, UEFI configuration, and the system configuration data after replacing the server board. All data is automatically backed up in a backup flash device rSPI card automatically. If BIOS detects a new server board and the Service Tag in the backup flash device rSPI card, BIOS prompts the user to restore the backup information.

1 Turn on the system.

If BIOS detects a new server board, and if the Service Tag is present in the backup flash device rSPI card, BIOS displays the Service Tag, the status of the license, and the UEFI Diagnostics version.

2 Perform one of the following steps:

- Press **Y** to restore the Service Tag, license, and diagnostics information.
- Press **N** to navigate to the Dell Lifecycle Controller based restore options.
- Press F10 to restore data from a previously created **Hardware Server Profile**.

After the restore process is complete, BIOS prompts to restore the system configuration data.

3 Perform one of the following steps:

- Press **Y** to restore the Service Tag, license, and diagnostics information.

After the restore process is complete, BIOS prompts to restore the system configuration data.

4 Perform one of the following steps:

- Press **Y** to restore the system configuration data.
- Press **N** to use the default configuration settings.

After the restore process is complete, the system restarts.

## Mini PERC battery

### Removing Mini PERC battery

1 Follow the safety guidelines listed in the Safety instructions section.

2 Complete the procedure listed in Before working inside your system.

1 Disconnect the Mini PERC and PERC battery cables.

2 Press the release latch to release the Mini PERC battery.

3 Slide the Mini PERC battery out of the air shroud to remove.

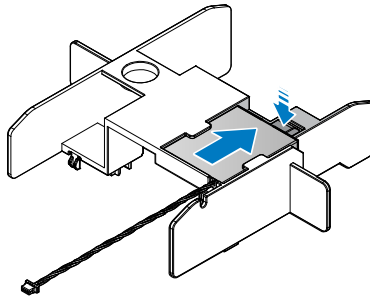

**Figure 49. Removing the Mini PERC battery**

- 1 Install the Mini PERC battery.
- 2 Complete the procedure listed in After working inside your system.

## Installing Mini PERC battery

**⚠ WARNING:** There is a danger of a new battery exploding if it is incorrectly installed. Replace the battery only with the same or equivalent type recommended by the manufacturer. For more information, see the safety information that shipped with your system.

**⚠ CAUTION:** Many repairs may only be done by a certified service technician. You should only perform troubleshooting and simple repairs as authorized in your product documentation, or as directed by the online or telephone service and support team. Damage due to servicing that is not authorized by Dell is not covered by your warranty. Read and follow the safety instructions that are shipped with your product.

- 1 Follow the safety guidelines listed in the Safety instructions section.
- 2 Complete the procedure listed in Before working inside your system.

- 1 Slide the Mini PERC battery into the slot on the air shroud. Make sure the cable is routed through the top of the air shroud.

**⚠ WARNING:** Do not use the cables on the PERC battery to pull the PERC battery in place to prevent fraying the cables.

- 2 Continue to slide the PERC battery into the air shroud until it is fully flush in place.

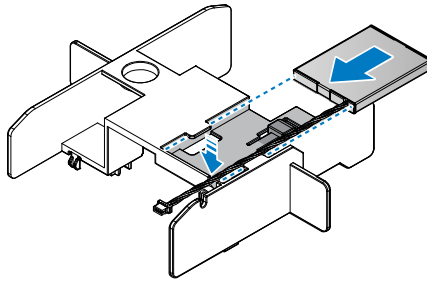

**Figure 50. Installing the Mini PERC battery**

- 3 Connect the PERC battery and Mini PERC cables.
- 1 Complete the procedure listed in After working inside your system.

## Supercaps

### Removing Microsemi supercap

- 1 Follow the safety guidelines listed in the Safety instructions section.
- 2 Complete the procedure listed in Before working inside your system.
- 1 Pull the latch to unlock the supercap assembly.
- 2 Slide the supercap assembly out and pull up to remove.

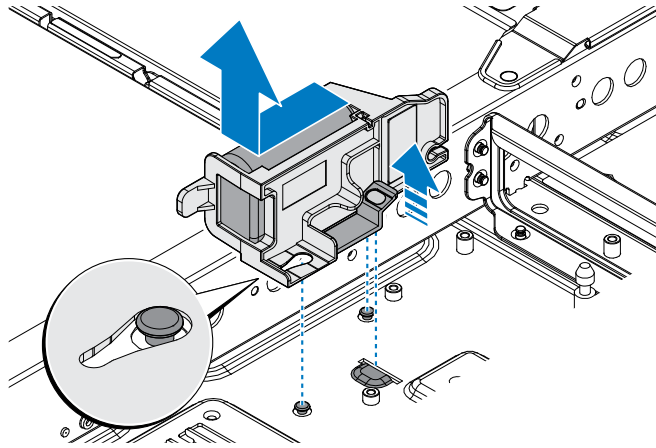

**Figure 51. Removing the supercap assembly**

- 3 Remove the cable from the indentation on the supercap holder.

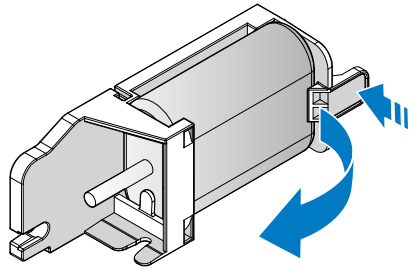

**Figure 52. Separating the supercap battery cable from holder**

- 4 Press the release latch to release the supercap.
- 5 After the battery clears the clip on the release latch, angle the free end out of the holder.
- 6 Slide the battery out and pull the cable through.

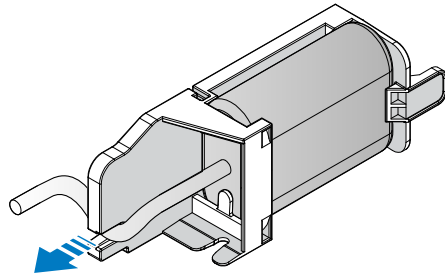
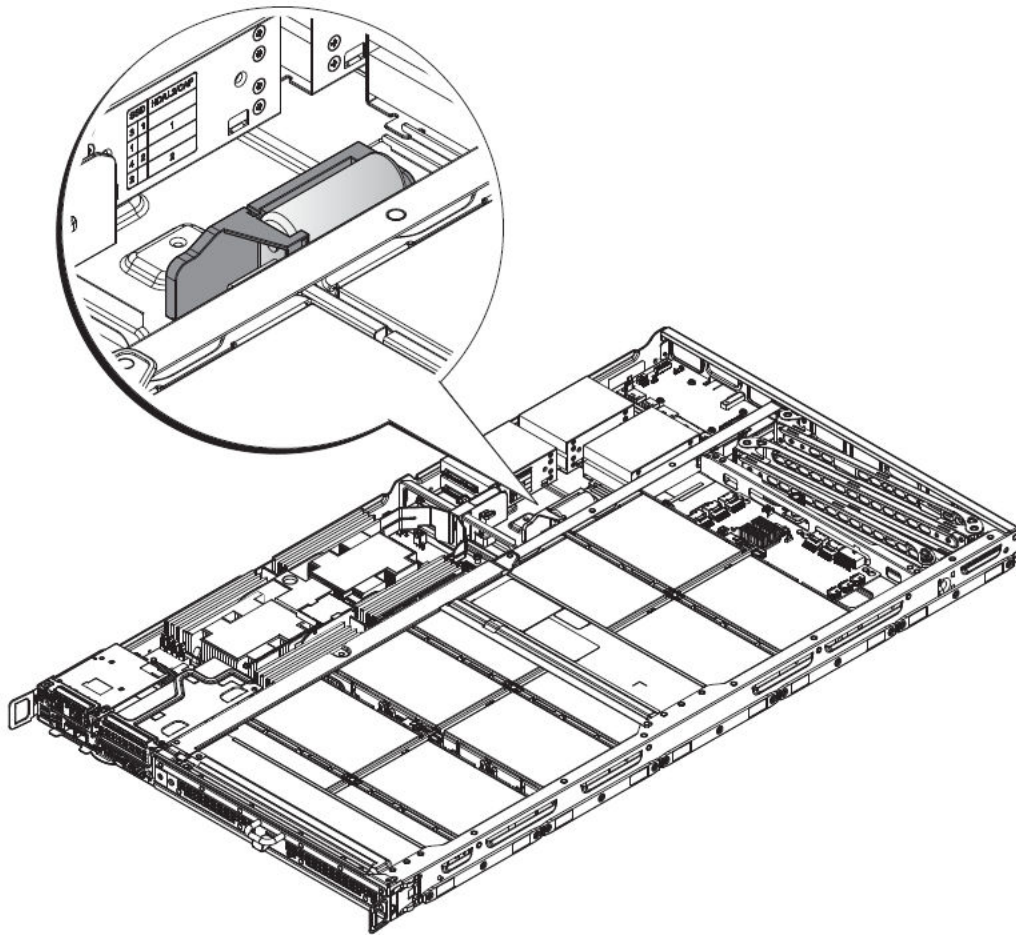

**Figure 53. Removing the supercap battery from holder**

- 7 Disconnect the cable.
- 1 Replace the Microsemi supercap battery.
- 2 Complete the procedure listed in After working inside your system.

## Installing Microsemi supercap

- 1 Follow the safety guidelines listed in the Safety instructions section. Safety instructions.
- 2 Complete the procedure listed in Before working inside your system.
- 1 Locate the place holder.



**Figure 54. Locating the supercap**

- 2 Insert the cable through the holder.
- 3 Angle the cable through the holder and slide in place. Make sure the cable is not caught underneath the battery.
- 4 Push the raised end of the battery into the holder.

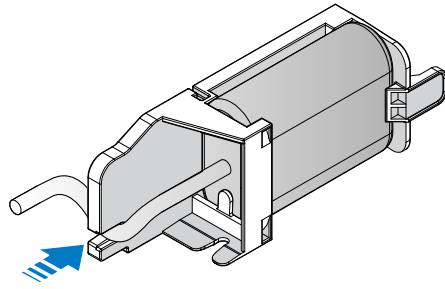

**Figure 55. Installing the supercap**

- 5 Insert the battery cable through the indentation on the supercap holder. The battery cable is secured after it is installed in the slit.

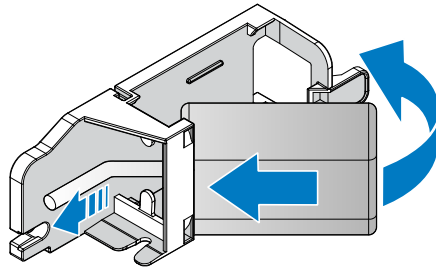

**Figure 56. Inserting the supercap cable in holder**

- 6 Align the supercap assembly in the chassis.
- 7 Install the supercap assembly and slide to seat properly.

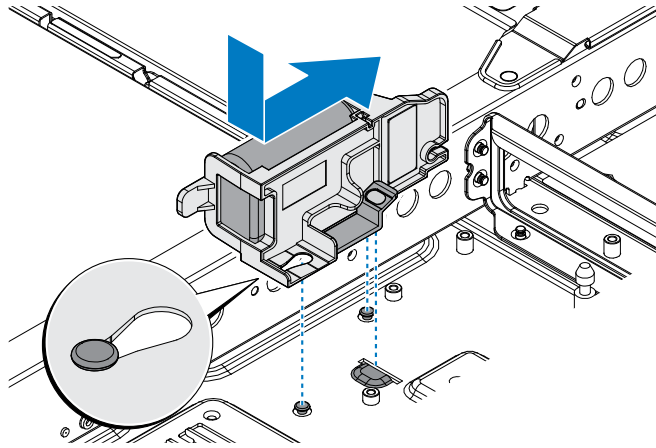
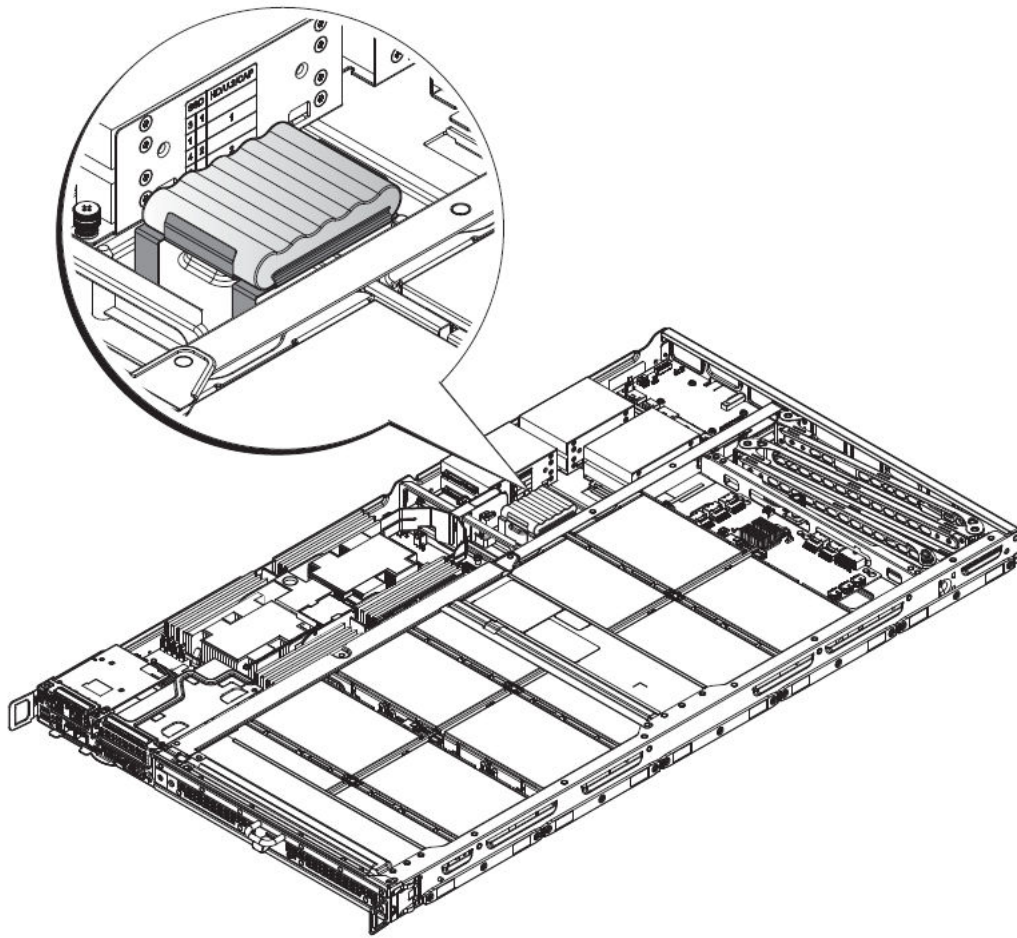

**Figure 57. Installing the supercap assembly**

- 1 Complete the procedure listed in After working inside your system.

## Removing Broadcom supercap

- 1 Follow the safety guidelines listed in the Safety instructions section.
- 2 Complete the procedure listed in Before working inside your system.
- 1 Locate the supercap battery and disconnect the supercap cable.



**Figure 58. Locating the supercap**

- 2 Grasp the one end of the battery and lift it up to remove it from the holder.

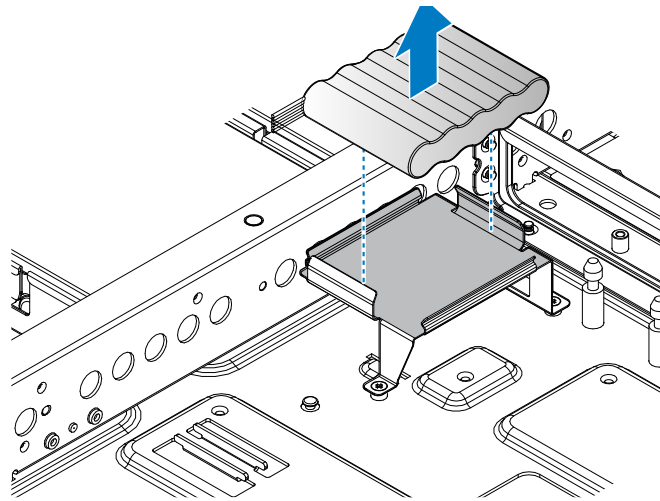
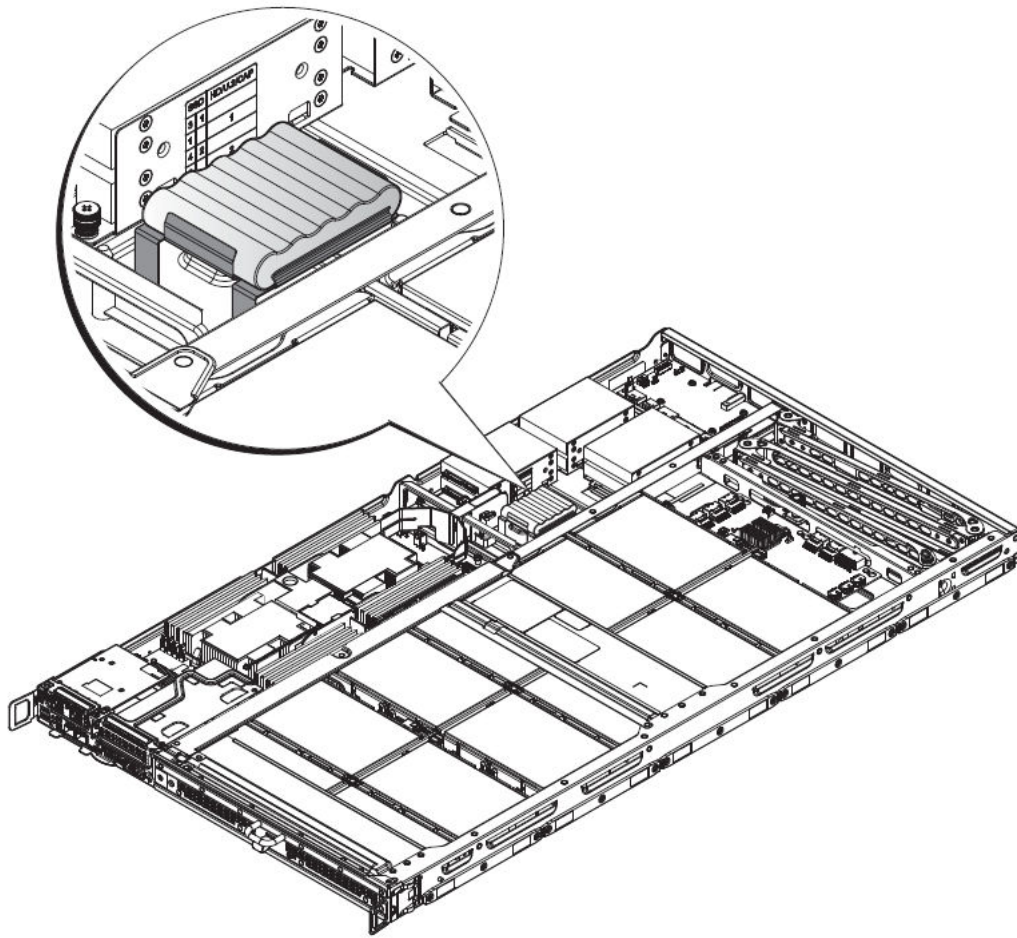

**Figure 59. Removing the supercap battery**

- 1 Replace the Broadcom supercap battery.
- 2 Complete the procedure listed in After working inside your system.

## Installing Broadcom supercap

- 1 Follow the safety guidelines listed in the Safety instructions section.
  - 2 Complete the procedure listed in Before working inside your system.
- 1 Locate the place holder in the assigned location. The screw holes on the chassis and holder align when the holder is placed correctly.



**Figure 60. Locating the supercap**

- 2 Insert the screws in the holder and tighten to secure the holder in place.

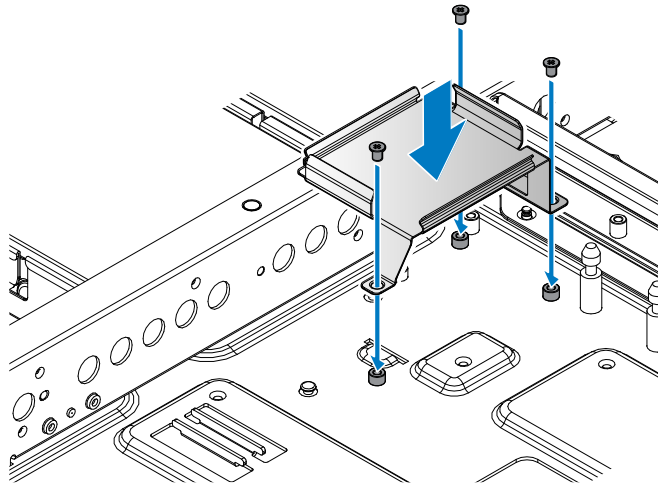

**Figure 61. Installing the battery holder**

**Table 49. Assembly material**

Description	Quantity	Torque (lbs/inch)
M3 Screw	3	6 ± 0.2

- 3 Position the cable to allow access for front-side routing.
- 4 Insert the battery into the holder and gently press it down until it is secured.

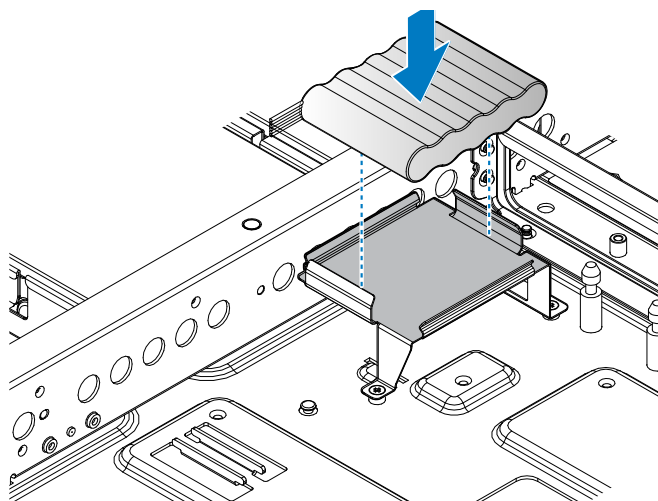

Figure 62. Installing the battery into a holder

- 1 Complete the procedure listed in After working inside your system.

## Mezzanine card and Mini PERC

### Removing mezzanine card

- 1 Ensure that you read the Safety instructions.
  - 2 Complete the procedure listed in Before working inside your system.
- 1 Remove the securing screws from the mezzanine card assembly.
  - 2 Remove the mezzanine card assembly from the chassis.

**NOTE:** You must install an expansion card filler cover over an empty expansion slot to maintain Federal Communications Commission (FCC) certification of the system. The covers also keep dust and dirt out of the system and aid in proper cooling and airflow inside the system.

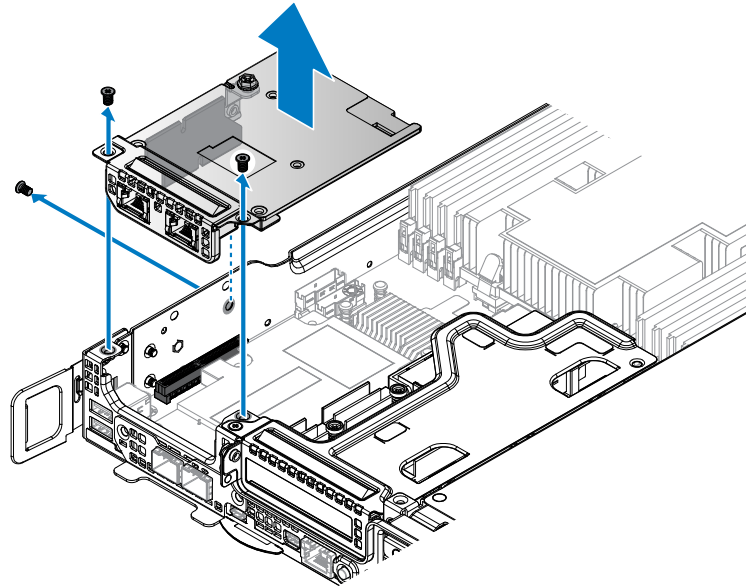

**Figure 63. Removing the mezzanine card assembly**

- 3 Remove the bridge board from the mezzanine card assembly.

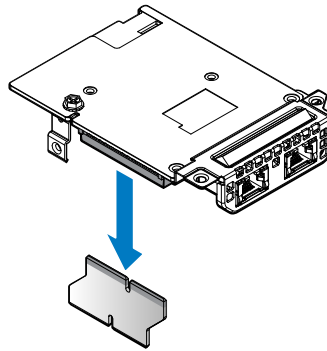

**Figure 64. Removing the bridge board from the mezzanine card**

- 4 Remove the securing screws from the mezzanine brackets.
- 5 Remove the support bracket and slot cover from the mezzanine card.

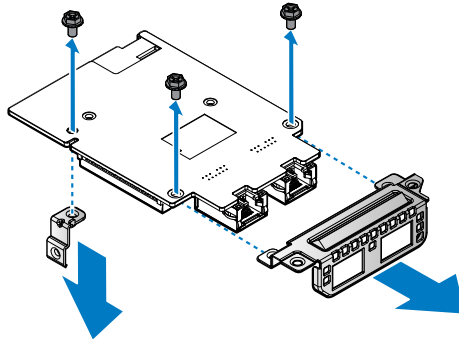
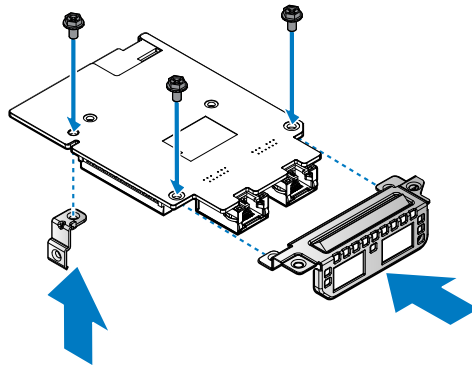

**Figure 65. Removing the support bracket and slot cover**

- 1 Install the mezzanine card.
- 2 Complete the procedure listed in After working inside your system.

## Installing mezzanine card

- 1 Ensure that you read the Safety instructions.
  - 2 Complete the procedure listed in Before working inside your system.
- 1 Align the holes on mezzanine card with the holes on support bracket and slot cover.
  - 2 Secure the support bracket and slot cover with screws.

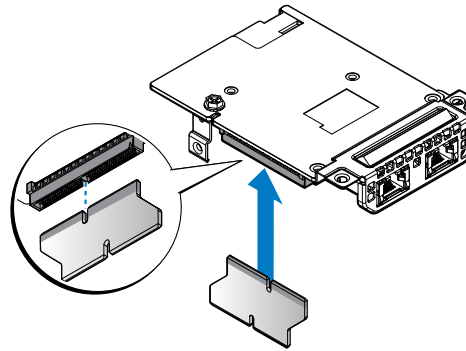

**Figure 66. Installing the support bracket and slot cover**

**Table 50. Assembly material**

Description	Quantity	Torque (lbs/inch)
#6-32 screw	3	6 ± 0.2

- 3 Align the bridge board with the mezzanine card connector.
- 4 Install the bridge board.



**Figure 67. Installing the bridge board on the mezzanine card**

- 5 Align the mezzanine card assembly with the screw posts on the chassis and the connector on the server board.
- 6 Press the mezzanine card assembly into the server board connector until it is fully seated.
- 7 Secure the mezzanine card assembly with provided screws.

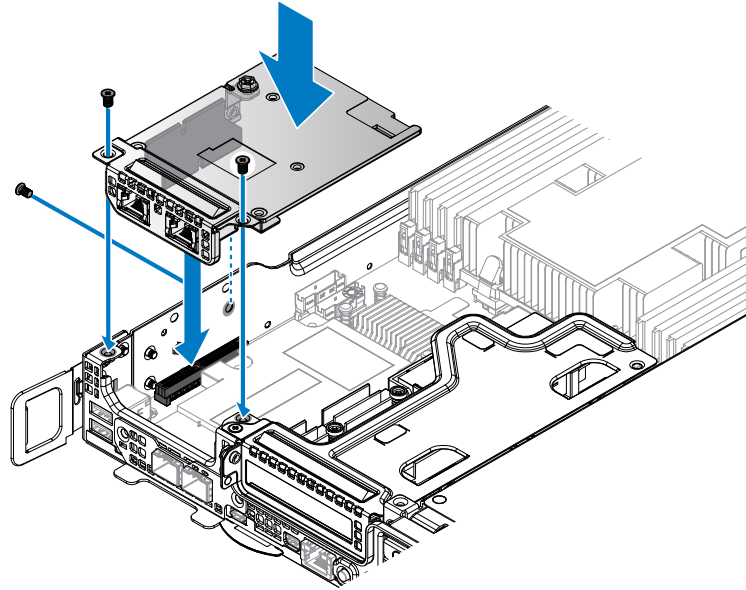

Figure 68. Installing the mezzanine card assembly

Table 51. Assembly material

Description	Quantity	Torque (lbs/inch)
#6-32 screw	3	6 ± 0.2

- 1 Complete the procedure listed in After working inside your system.

## Removing Mini PERC

- 1 Ensure that you read the Safety instructions.
- 2 Complete the procedure listed in Before working inside your system.
- 1 Remove the securing screws from the Mini PERC assembly.
- 2 Remove the Mini PERC assembly from the chassis.

**NOTE:** You must install an expansion card filler cover over an empty expansion slot to maintain Federal Communications Commission (FCC) certification of the system. The covers also keep dust and dirt out of the system and aid in proper cooling and airflow inside the system.

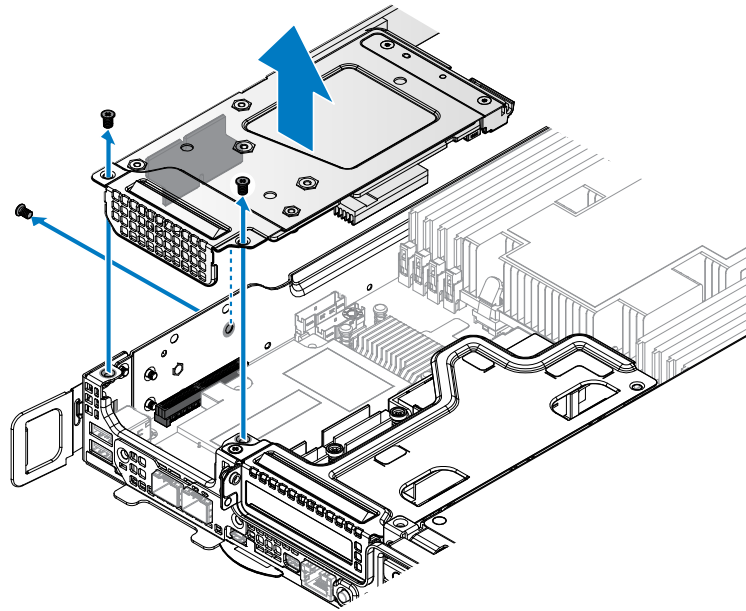

**Figure 69. Removing the Mini PERC assembly**

- 3 Remove the bridge board from the Mini PERC assembly.

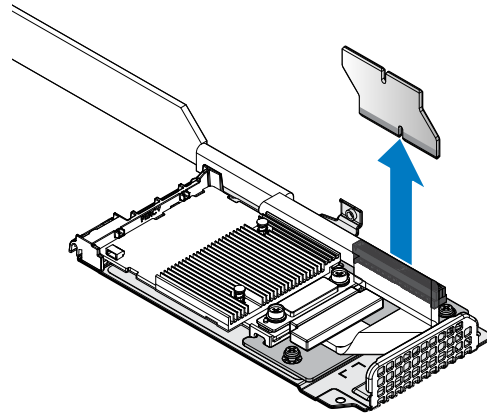

**Figure 70. Removing the bridge board from the Mini PERC assembly**

- 4 Loosen the captive screws securing the Mini PERC cable and the Mini PERC card.
- 5 Remove the Mini PERC cable.
- 6 Grasp the ends of the Mini PERC card and remove it.

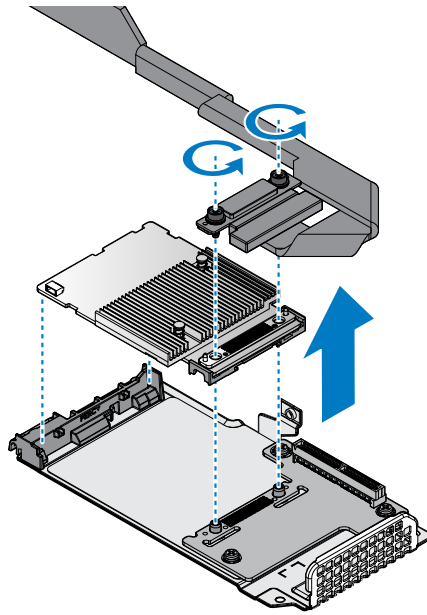

**Figure 71. Removing the Mini PERC cable and card**

- 7 Remove the screws securing the riser board.
- 8 Remove the bezel and riser board from the mezzanine bracket.

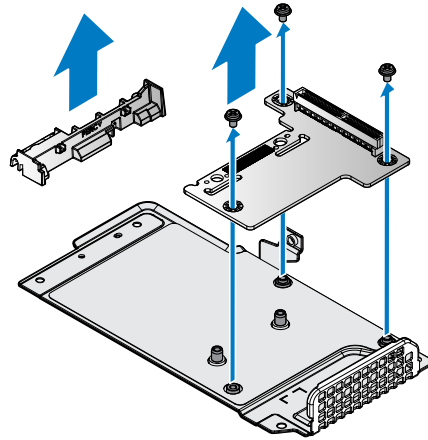
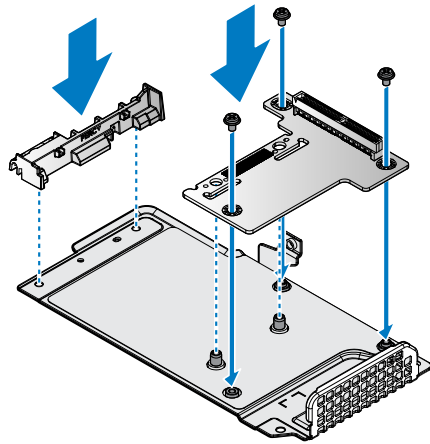

**Figure 72. Removing the bezel and riser board**

- 1 Install the Mini PERC.
- 2 Complete the procedure listed in After working inside your system.

## Installing Mini PERC

- 1 Ensure that you read the Safety instructions.
  - 2 Complete the procedure listed in Before working inside your system.
- 1 Align the holes on riser board with the holes on mezzanine brackets.
  - 2 Secure the mezzanine brackets with screws.
  - 3 Align the bezel with the mezzanine bracket and install.

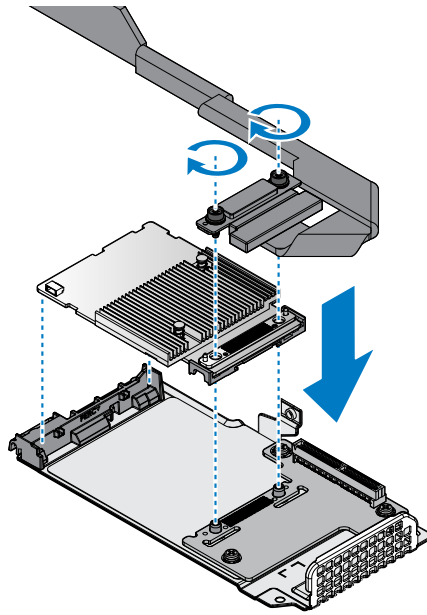

**Figure 73. Installing the bezel and riser board**

**Table 52. Assembly material**

Description	Quantity	Torque (lbs/inch)
#6-32 screw	3	6 ± 0.2

- 4 Align the Mini PERC on the riser board making sure the screw holes line up.
- 5 Install the Mini PERC card on the bezel and riser board.
- 6 Place the PERC cable over the Mini PERC connectors and install.
- 7 Secure the Mini PERC cable and the Mini PERC with the captive screws.

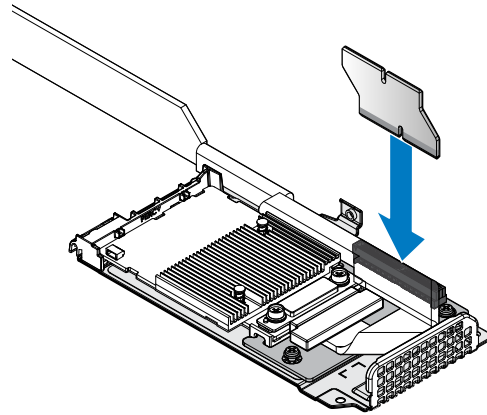

**Figure 74. Assembling the Mini PERC card and cable on the bracket**

**Table 53. Assembly material**

Description	Quantity	Torque (lbs/inch)
FIX screw	2	6 ± 0.2

- 8 Align the bridge board with the riser board connector.
- 9 Install the bridge board.



**Figure 75. Installing the bridge board on the Mini PERC assembly**

- 10 Turn the Mini PERC assembly over and align it with the screw posts on the chassis and the connector on the server board.
- 11 Press the Mini PERC assembly into the server board connector until it is fully seated.
- 12 Secure the Mini PERC assembly with the provided screws.

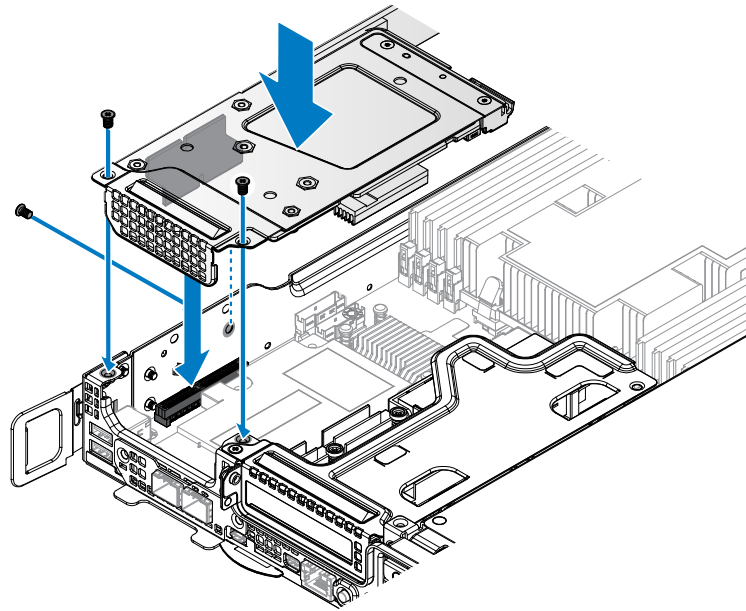

Figure 76. Installing the Mini PERC assembly

Table 54. Assembly material

Description	Quantity	Torque (lbs/inch)
#6-32 screw	3	6 ± 0.2

- 1 Complete the procedure listed in After working inside your system.

## M.2 SSD Module

### Removing x8 PCIe M.2 card

- 1 Ensure that you read the Safety instructions.
  - 2 Complete the procedure listed in Before working inside your system.
- 1 Remove the securing screws from the PCIe M.2 assembly.
  - 2 Remove the PCIe M.2 assembly from the chassis.

**NOTE:** You must install an expansion card filler cover over an empty expansion slot to maintain Federal Communications Commission (FCC) certification of the system. The covers also keep dust and dirt out of the system and aid in proper cooling and airflow inside the system.

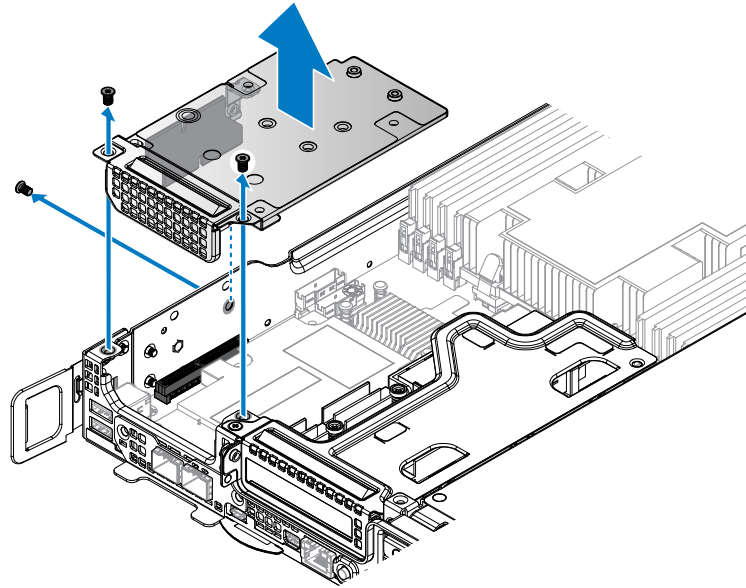

**Figure 77. Removing the PCIe M.2 assembly**

- 3 Remove the bridge board from the PCIe M.2 assembly.

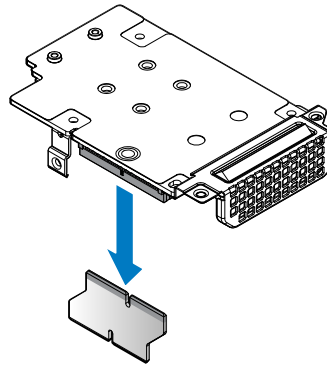

**Figure 78. Removing the bridge board from the mezzanine card**

- 4 Flip over the PCIe M.2 assembly.
- 5 Loosen the screw securing the PCIe M.2 card to the M.2 SSD board.
- 6 The M.2 SSD board pops up. Grasp the card and slide it out.

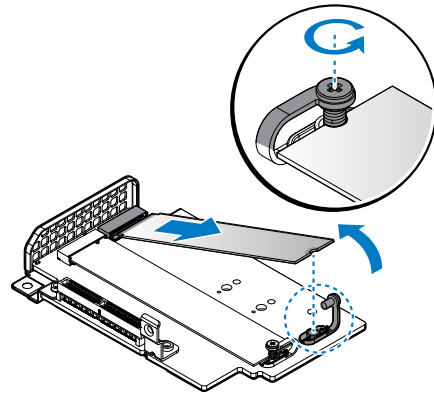

**Figure 79. Removing the M.2 SSD board**

- 7 Remove the securing screws from the mezzanine brackets.
- 8 Remove the support bracket and slot cover from the PCIe M.2 card.

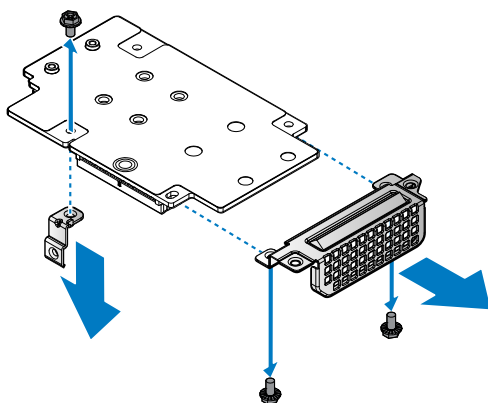
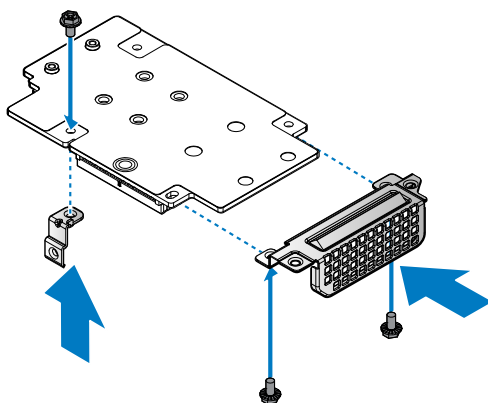

**Figure 80. Removing the support bracket and slot cover**

- 1 Install the PCIe M.2 card.
- 2 Complete the procedure listed in After working inside your system.

## Installing x8 PCIe M.2 card

- 1 Ensure that you read the Safety instructions.
  - 2 Complete the procedure listed in Before working inside your system.
- 1 Align the holes on the PCIe M.2 card with the holes on support bracket and slot cover.
  - 2 Secure the support bracket and slot cover with screws.

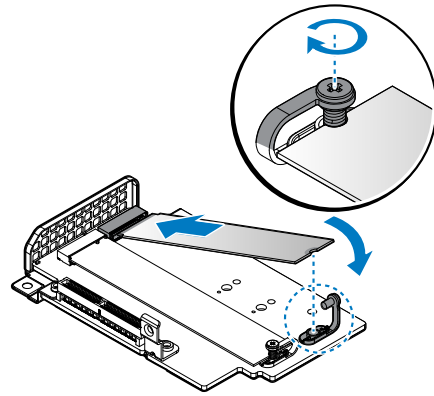

**Figure 81. Installing the support bracket and slot cover**

**Table 55. Assembly material**

Description	Quantity	Torque (lbs/inch)
#6-32 screw	3	6 ± 0.2

- 3 Flip over the PCIe M.2 assembly.
- 4 Align the M.2 SSD board with the protrusion in the PCIe M.2 card.
- 5 Insert the M.2 SSD until it is fully seated in the connector.
- 6 Lower the M.2 SSD board and hold it in place.
- 7 Secure the M.2 SSD board to the PCIe M.2 card with the captive screw.



**Figure 82. Installing the M.2 SSD board**

- 8 Align the bridge board in the PCIe M.2 card connector.
- 9 Install the bridge board.

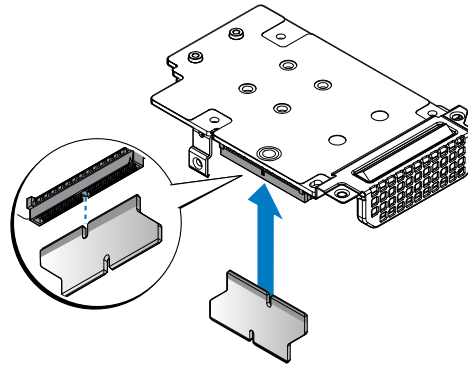

**Figure 83. Installing the bridge board on the mezzanine card**

- 10 Align the PCIe M.2 assembly with the screw posts on the chassis and the connector on the server board.
- 11 Press the PCIe M.2 assembly into the server board connector until it is fully seated.
- 12 Secure the PCIe M.2 assembly with provided screws.

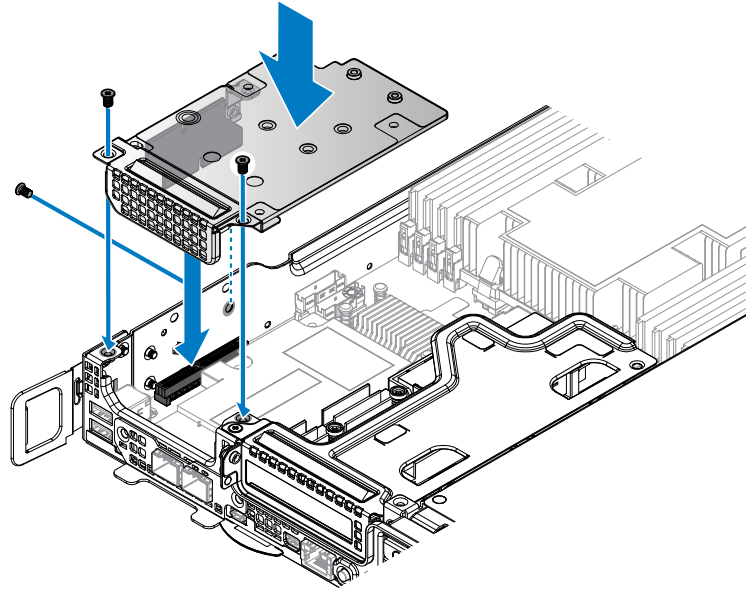

Figure 84. Installing the PCIe M.2 assembly

Table 56. Assembly material

Description	Quantity	Torque (lbs/inch)
#6-32 screw	3	6 ± 0.2

- 1 Complete the procedure listed in After working inside your system.

## Removing x8 SATA M.2 card

- 1 Ensure that you read the Safety instructions.
- 2 Complete the procedure listed in Before working inside your system.
- 1 Remove the securing screws from the SATA M.2 assembly.
- 2 Remove the SATA M.2 assembly from the chassis.

**NOTE:** You must install an expansion card filler cover over an empty expansion slot to maintain Federal Communications Commission (FCC) certification of the system. The covers also keep dust and dirt out of the system and aid in proper cooling and airflow inside the system.

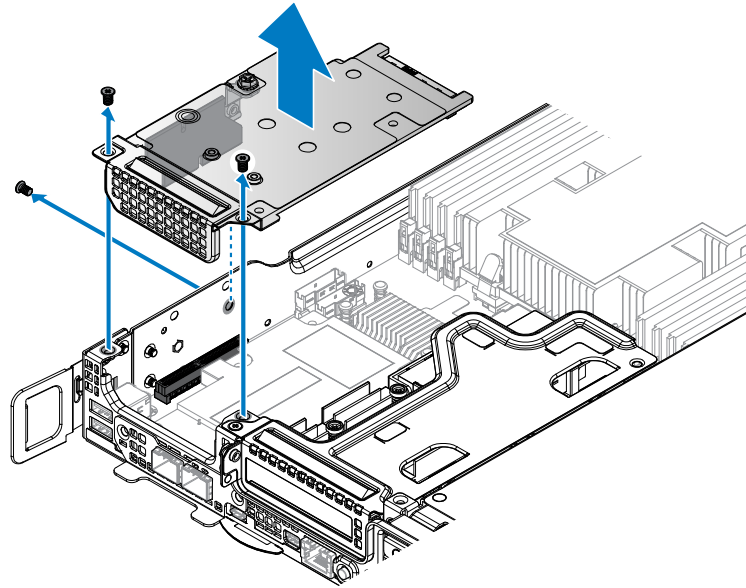

**Figure 85. Removing the SATA M.2 assembly**

- 3 Remove the bridge board from the SATA M.2 assembly.

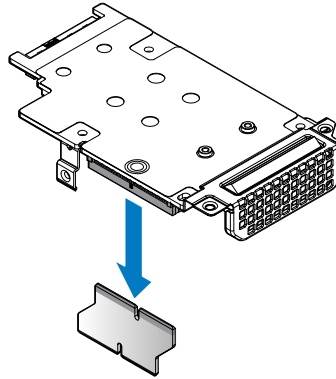

**Figure 86. Removing the bridge board from the mezzanine card**

- 4 Flip over the SATA M.2 assembly.
- 5 Loosen the screw securing the SATA M.2 card and M.2 SSD board.
- 6 The M.2 SSD board pops up. Grasp the board and slide it out.

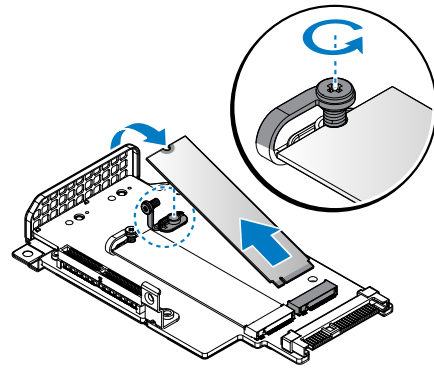

**Figure 87. Removing the M.2 SSD board**

- 7 Remove the securing screws from the mezzanine brackets.
- 8 Remove the support bracket and slot cover from the SATA M.2 card.

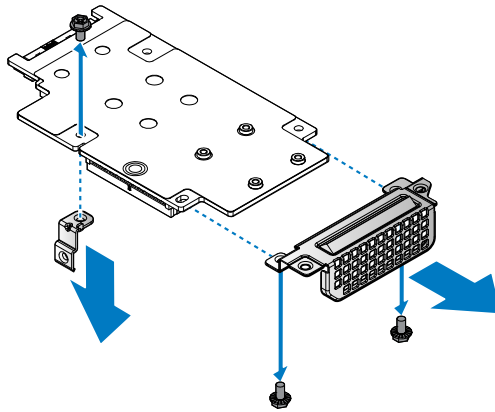
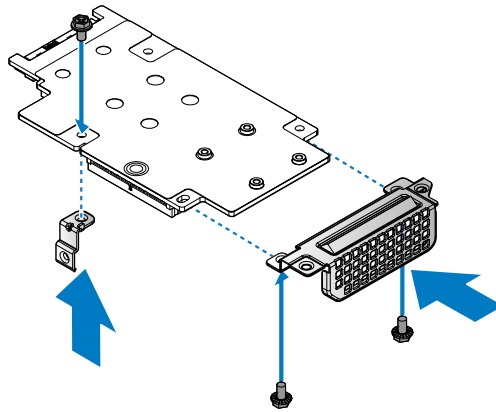

**Figure 88. Removing the support bracket and slot cover**

- 1 Install the SATA M.2 card.
- 2 Complete the procedure listed in After working inside your system.

## Installing x8 SATA M.2 card

- 1 Ensure that you read the Safety instructions.
  - 2 Complete the procedure listed in Before working inside your system.
- 1 Align the holes on the SATA M.2 card with the holes on support bracket and slot cover.
  - 2 Secure the support bracket and slot cover with screws.

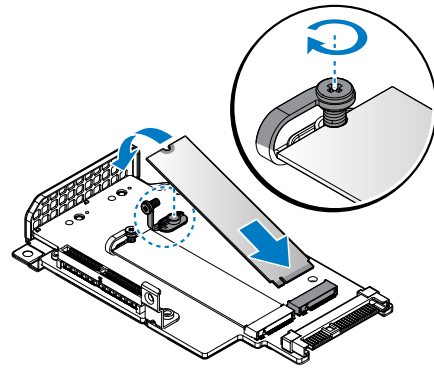

**Figure 89. Installing the support bracket and slot cover**

**Table 57. Assembly material**

Description	Quantity	Torque (lbs/inch)
#6-32 screw	3	6 ± 0.2

- 3 Flip over the SATA M.2 assembly.
- 4 Align the M.2 SSD board with the protrusion in the SATA M.2 card.
- 5 Insert the M.2 SSD until it is fully seated in the connector.
- 6 Lower the M.2 SSD board and hold it in place.
- 7 Secure the M.2 SSD board to the SATA M.2 card with the captive screw.



**Figure 90. Installing the M.2 SSD board**

- 8 Align the bridge board in the SATA M.2 card connector.
- 9 Install the bridge board.

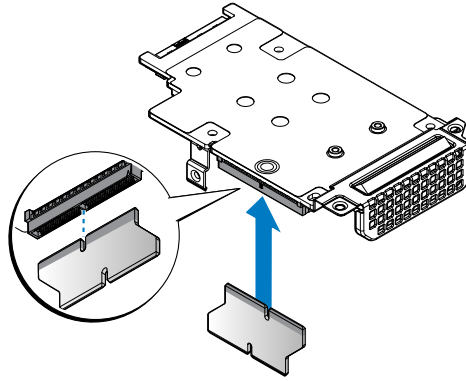

**Figure 91. Installing the bridge board on the mezzanine card**

- 10 Align the SATA M.2 assembly with the screw posts on the chassis and the connector on the server board.
- 11 Press the SATA M.2 assembly into the server board connector until it is fully seated.
- 12 Secure the SATA M.2 assembly with provided screws.

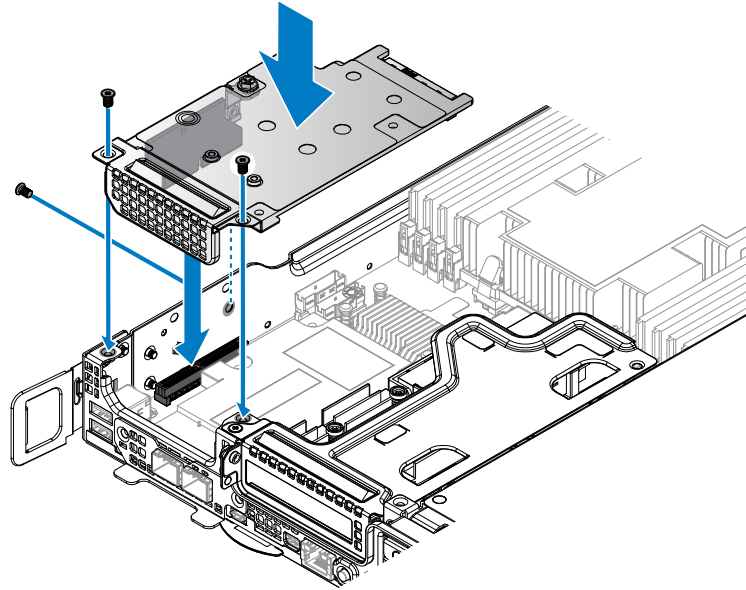

**Figure 92. Installing the SATA M.2 assembly**

**Table 58. Assembly material**

Description	Quantity	Torque (lbs/inch)
#6-32 screw	3	6 ± 0.2

- 1 Complete the procedure listed in After working inside your system.

## Removing x16 PCIe M.2 card

- 1 Ensure that you read the Safety instructions.
  - 2 Complete the procedure listed in Before working inside your system.
- 1 Loosen the captive screw securing the PCIe M.2 card.
  - 2 Unlock the hook from the PCIe M.2 card and remove the PCIe M.2 card from the server board.

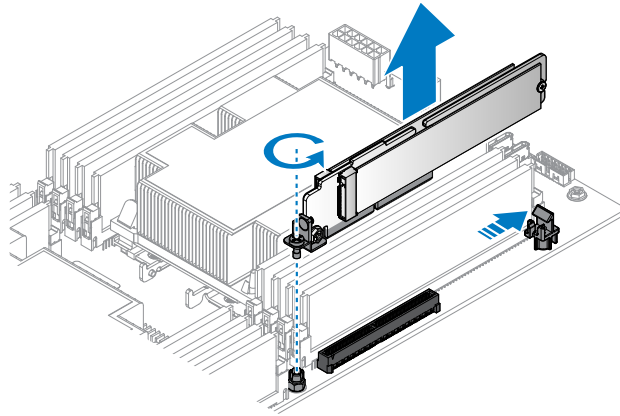

**Figure 93. Removing the PCIe M.2 card**

- 3 Remove the screw securing the PCIe M.2 card and M.2 SSD board.
- 4 Rotate the M.2 SSD board out and remove.

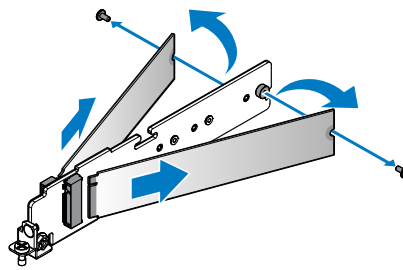

**Figure 94. Removing the M.2 SSD board**

- 5 Remove the securing screw from the PCIe M.2 card.
- 6 Remove the PCIe bracket from the PCIe M.2 card.

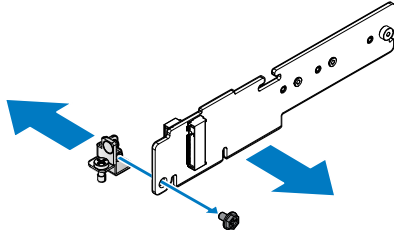
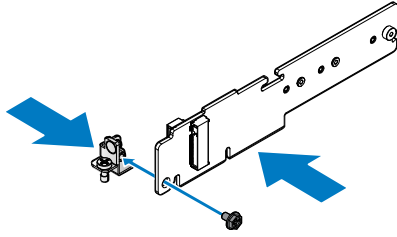

**Figure 95. Removing the PCIe bracket**

- 1 Install the PCIe M.2 card.
- 2 Complete the procedure listed in After working inside your system.

## Installing x16 PCIe M.2 card

- 1 Ensure that you read the Safety instructions.
  - 2 Complete the procedure listed in Before working inside your system.
- 1 Align the PCIe bracket with the PCIe M.2 card.
  - 2 Secure the PCIe bracket with the provided screws.

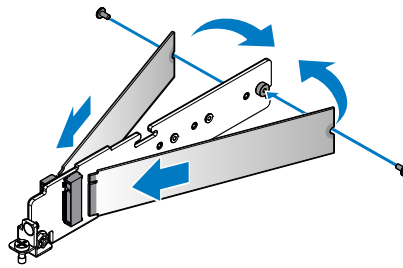

**Figure 96. Installing the PCIe bracket**

**Table 59. Assembly material**

Description	Quantity	Torque (lbs/inch)
M3 screw	1	6 ± 0.2

- 3 Align the M.2 SSD board with the protrusion in the PCIe M.2 card.
- 4 Insert the M.2 SSD until it is fully seated in the connector.
- 5 Lower the M.2 SSD board and hold it in place.
- 6 Insert the screws and tighten to secure.

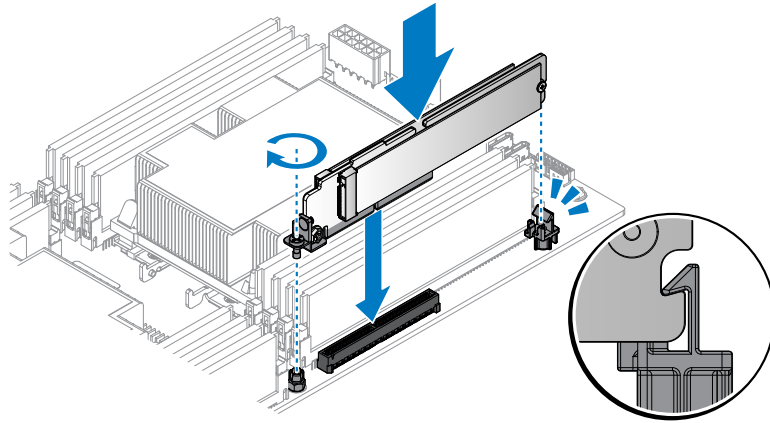

**Figure 97. Installing the M.2 SSD board**

**Table 60. Assembly material**

Description	Quantity	Torque (lbs/inch)
M2 x 4.5 mm	2	2.4~2.7

- 7 Align the PCIe M.2 card with the connector on the server board.
- 8 Press the PCIe M.2 card into the server board connector until it is fully seated. Make sure the hook is locked the PCIe M.2 card.
- 9 Tighten the captive screw on the PCIe bracket.

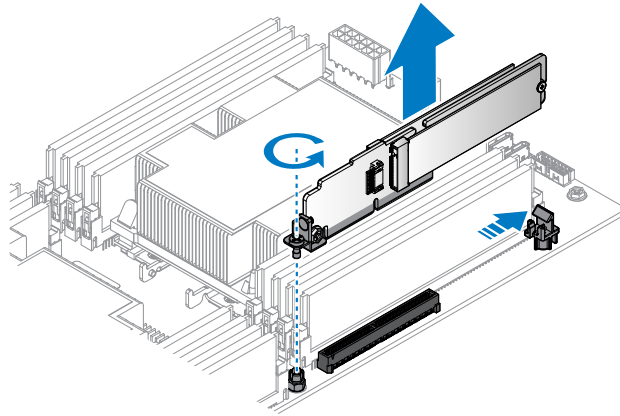

**Figure 98. Installing the PCIe M.2 card**

- 1 Complete the procedure listed in After working inside your system.

## Removing x16 SATA M.2 card

- 1 Ensure that you read the Safety instructions.
- 2 Complete the procedure listed in Before working inside your system.
  - 1 Loosen the captive screw securing the SATA M.2 card.
  - 2 Unlock the hook from the SATA M.2 card and remove the SATA M.2 card from the server board.



**Figure 99. Removing the SATA M.2 card**

- 3 Remove the screw securing the SATA M.2 card and M.2 SSD board.
- 4 Rotate the M.2 SSD board out and remove.

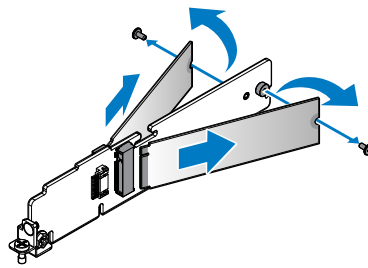

**Figure 100. Removing the M.2 SSD board**

- 5 Remove the securing screw from the SATA M.2 card.
- 6 Remove the PCIe bracket from the SATA M.2 card.

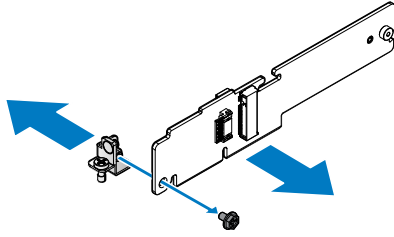
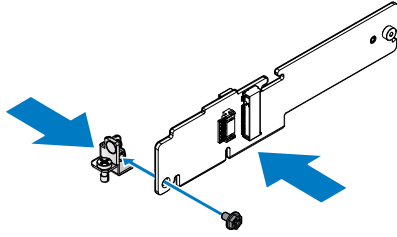

**Figure 101. Removing the PCIe bracket**

- 1 Install the SATA M.2 card.
- 2 Complete the procedure listed in After working inside your system.

## Installing x16 SATA M.2 card

- 1 Ensure that you read the Safety instructions.
  - 2 Complete the procedure listed in Before working inside your system.
- 1 Align the PCIe bracket with the SATA M.2 card.
  - 2 Secure the PCIe bracket with the provided screws.

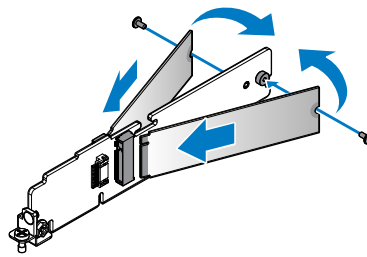

**Figure 102. Installing the PCIe bracket**

**Table 61. Assembly material**

Description	Quantity	Torque (lbs/inch)
M3 screw	1	6 ± 0.2

- 3 Align the M.2 SSD board with the protrusion in the SATA M.2 card.
- 4 Insert the M.2 SSD until it is fully seated in the connector.
- 5 Lower the M.2 SSD board and hold it in place.
- 6 Insert the screws and tighten to secure.

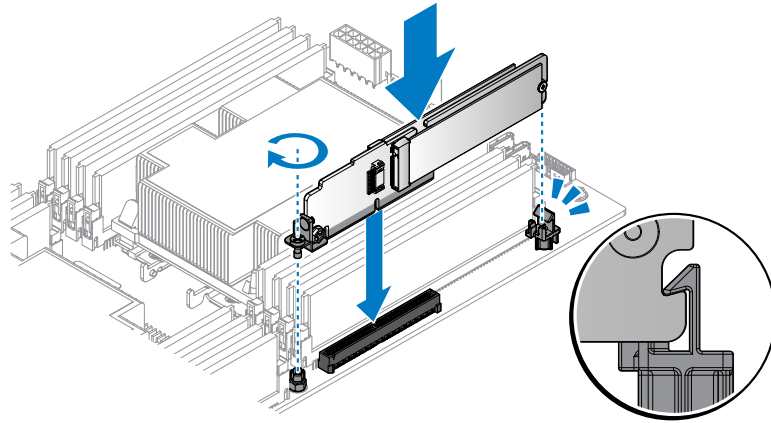

**Figure 103. Installing the M.2 SSD board**

**Table 62. Assembly material**

Description	Quantity	Torque (lbs/inch)
M2 x 4.5 mm	2	2.4~2.7

- 7 Align the SATA M.2 card with the connector on the server board.
- 8 Press the SATA M.2 card into the server board connector until it is fully seated. Make sure the hook is locked the SATA M.2 card.
- 9 Tighten the captive screw on the PCIe bracket.



**Figure 104. Installing the SATA M.2 card**

- 1 Complete the procedure listed in After working inside your system.

## PCIe card

### Removing PCIe card

- 1 Follow the safety guidelines listed in the Safety instructions section.
  - 2 Complete the procedure listed in Before working inside your system.
- 1 Remove the securing screws from the PCIe card assembly.
  - 2 Remove the PCIe card assembly from the chassis.

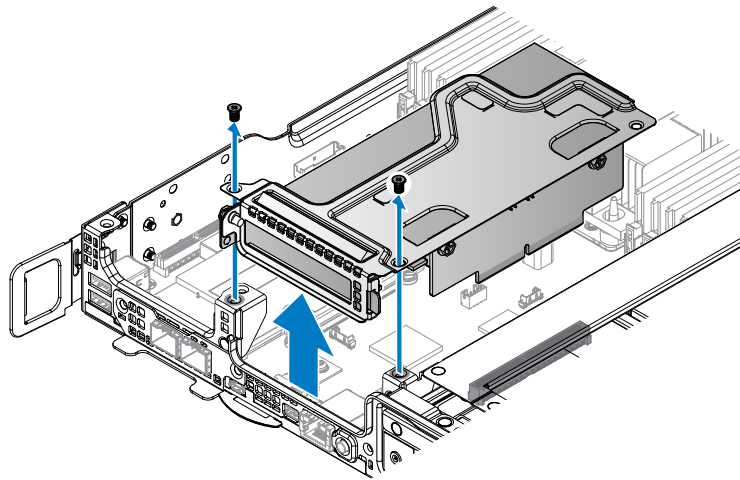

**Figure 105. Removing the PCIe card assembly**

- 3 Remove the securing screw from the PCIe card assembly.
- 4 Remove the PCIe card from the riser board.

**NOTE:** You must install an expansion card filler cover over an empty expansion slot to maintain Federal Communications Commission (FCC) certification of the system. The covers also keep dust and dirt out of the system and aid in proper cooling and airflow inside the system.

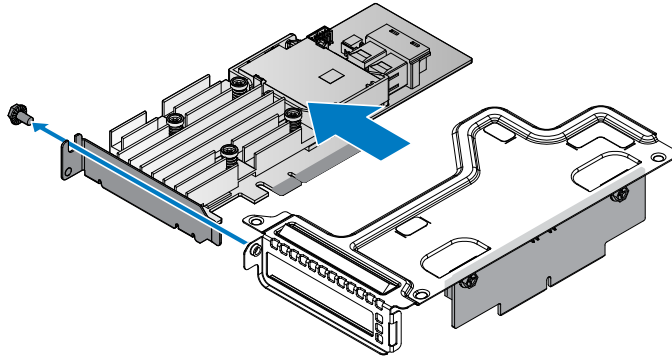

**Figure 106. Removing the PCIe card**

- 5 Remove the securing screws from the riser board.
- 6 Remove the riser board from the riser bracket.

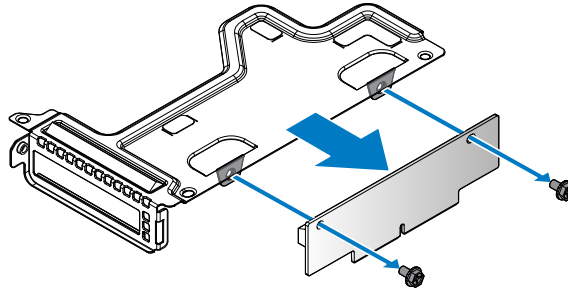

**Figure 107. Removing the riser board**

- 1 Install the PCIe card.
- 2 Complete the procedure listed in After working inside your system.
- 3 Install any device drivers needed for the card as described in the documentation for the card.

## Installing PCIe card

- 1 Follow the procedure listed in the After working inside your system.
- 2 Complete the procedure listed in Before working inside your system.
- 1 Remove the screws securing the riser bracket.
- 2 Remove the riser bracket from the chassis.

**NOTE:** The PCIe bracket is customized for this system. Retain the bracket if replacing a new PCIe card for use with the new PCIe card.

- 3 Align the holes on riser board with the holes on riser bracket.
- 4 Secure the riser board with screws.

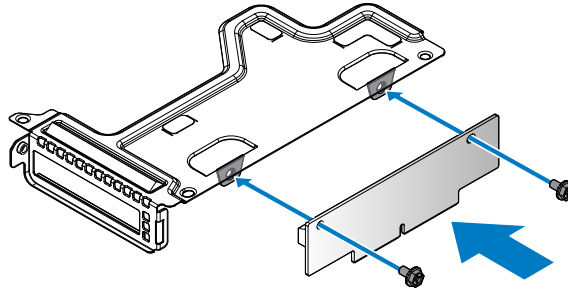

Figure 108. Installing the riser board on a bracket

Table 63. Assembly material

Description	Quantity	Torque (lbs/inch)
#6-32 screw	2	6 ± 0.2

- 5 Align the PCIe card with the riser bracket and the riser board connector.
- 6 Insert the PCIe card in the connector on the riser board.
- 7 Secure the PCIe card with the provided screw.

**NOTE:** You must install an expansion card filler cover over an empty expansion slot to maintain Federal Communications Commission (FCC) certification of the system. The covers also keep dust and dirt out of the system and aid in proper cooling and airflow inside the system.

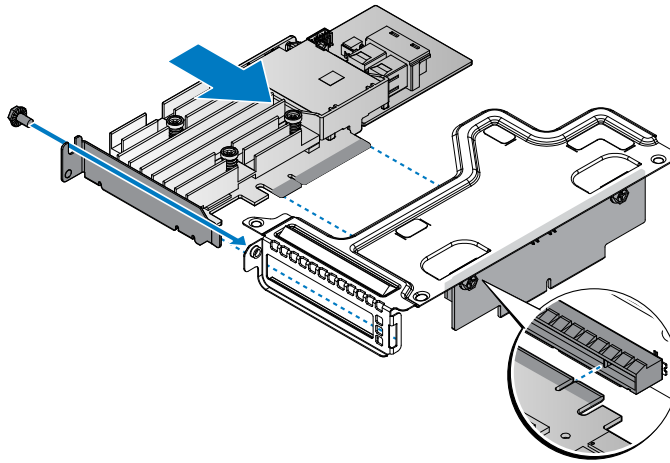

**Figure 109. Installing the PCIe card in a bracket**

**Table 64. Assembly material**

Description	Quantity	Torque (lbs/inch)
#6-32 screw	1	6 ± 0.2

- 8 Align the PCIe card assembly with the screw posts on the chassis and the connector on the server board.
- 9 Press the PCIe card assembly into the server board connector until it is fully seated.
- 10 Secure the PCIe card assembly with the provided screws.

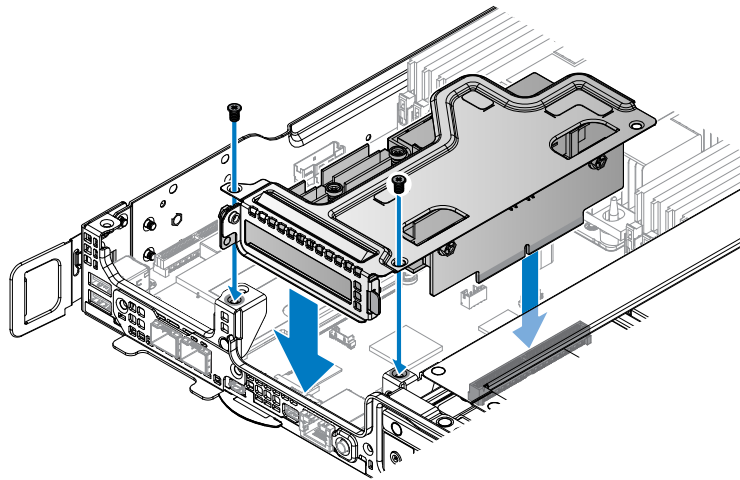

Figure 110. Installing the PCIe card assembly

Table 65. Assembly material

Description	Quantity	Torque (lbs/inch)
#6-32 screw	2	6 ± 0.2

- 1 Follow the procedure listed in the After working inside your system.
- 2 Install any device drivers needed for the card as described in the documentation for the card.

## OCP card

### Removing OCP card from slot 1

- 1 Ensure that you read the Safety instructions.
  - 2 Complete the procedure listed in Before working inside your system.
- 1 Remove the securing screws from the OCP card assembly.
  - 2 Remove the OCP card assembly from the chassis.

**NOTE:** You must install an expansion card filler cover over an empty expansion slot to maintain Federal Communications Commission (FCC) certification of the system. The covers also keep dust and dirt out of the system and aid in proper cooling and airflow inside the system.

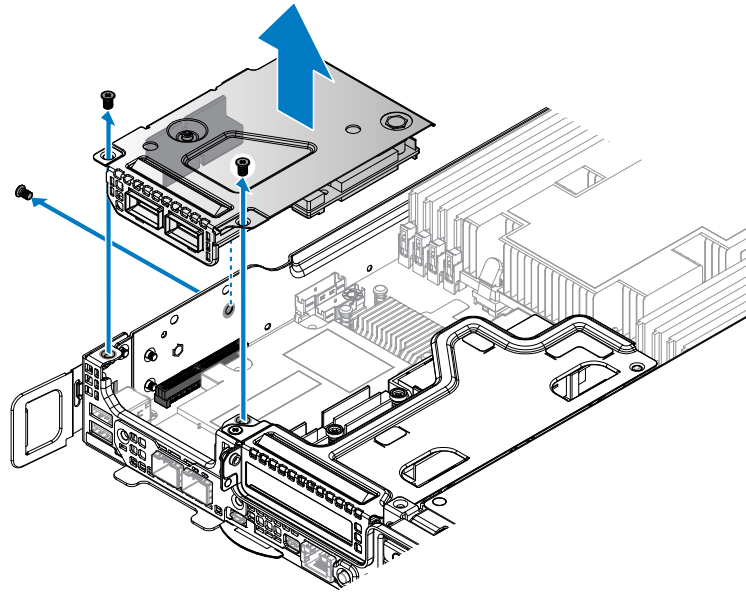

**Figure 111. Removing the OCP card assembly**

- 3 Remove the bridge board from the OCP card assembly.

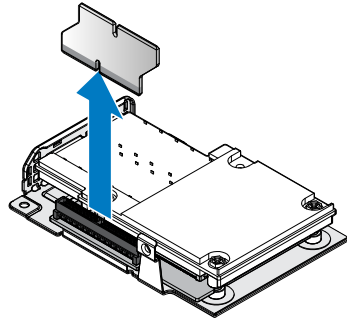

**Figure 112. Removing the bridge board from the OCP assembly**

- 4 Remove the securing screws from the OCP card.
- 5 Grasp the rearside of the OCP card and lift it up to clear the connector on the transfer board. Do not remove it completely.
- 6 Slide the OCP card out to allow the ports on the OCP card to clear the bracket.
- 7 Remove the OCP card.

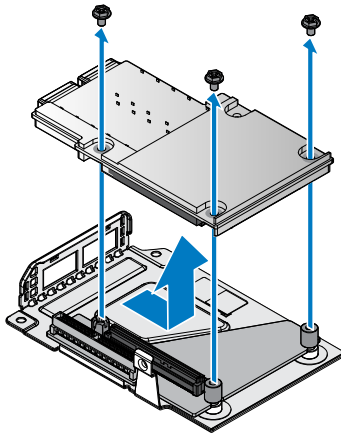

**Figure 113. Removing the OCP card**

- 8 Remove the securing standoff screw from the transfer board.
- 9 Slide the transfer board to release it from the securing pin on the OCP bracket and remove it.

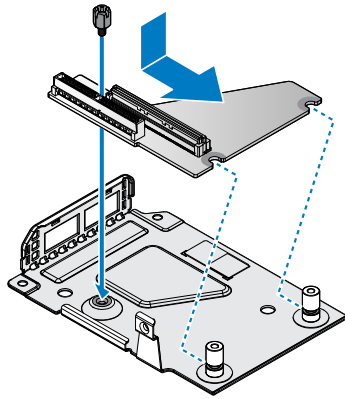
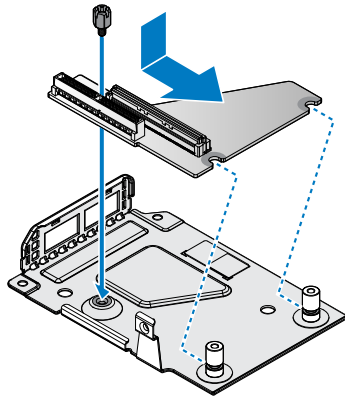

**Figure 114. Removing the transfer board**

- 1 Install the OCP card into slot 1.
- 2 Complete the procedure listed in After working inside your system.

## Installing OCP card into slot 1

- 1 Ensure that you read the Safety instructions.
  - 2 Complete the procedure listed in Before working inside your system.
- 1 Align the slits on the transfer board with the securing pins on the OCP bracket.
  - 2 Slide the transfer board into the pins until the securing holes on the transfer board and OCP bracket align.
  - 3 Secure the transfer board with a standoff screw.



**Figure 115. Installing the transfer board**

**Table 66. Assembly material**

Description	Quantity	Torque (lbs/inch)
#6-32 screw	1	6 ± 0.2

- 4 Angle the OCP card over the OCP bracket and insert the ports in the slots on the bracket.
- 5 Align the connectors on the OCP card with the slot on the transfer board and lower the OCP card in place. Gently press it in place to seat it correctly.
- 6 Secure the OCP card with screws.

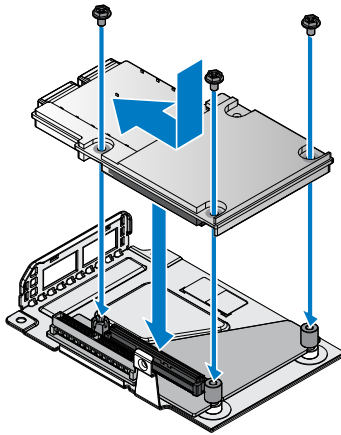
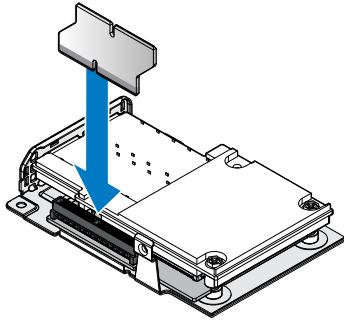

Figure 116. Installing the OCP card

Table 67. Assembly material

Description	Quantity	Torque (lbs/inch)
#6-32 screw	3	6 ± 0.2

- 7 Align the bridge board with the transfer board connector.
- 8 Install the bridge board.



**Figure 117. Installing the bridge board on the transfer board**

- 9 Turn the OCP card assembly over and align it with the screw posts on the chassis and the connector on the server board.
- 10 Press the OCP card assembly into the server board connector until it is fully seated.
- 11 Secure the OCP card assembly with provided screws.

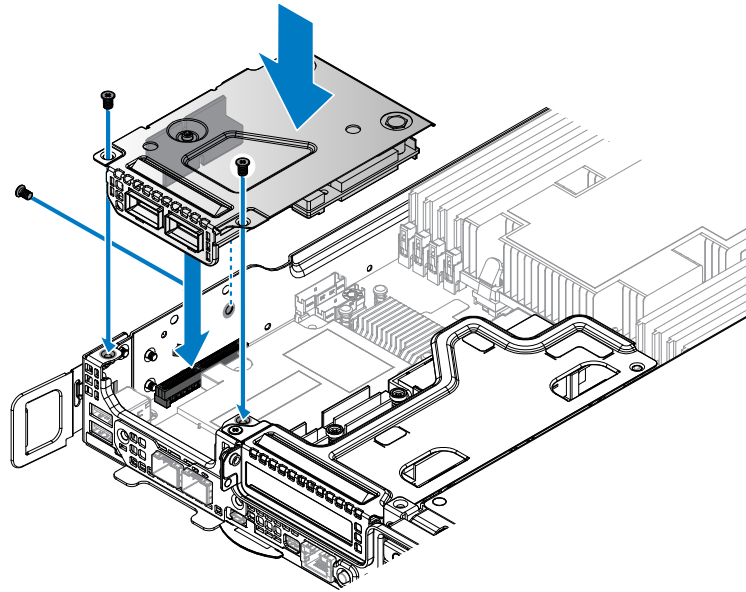

**Figure 118. Installing the OCP card assembly**

**Table 68. Assembly material**

Description	Quantity	Torque (lbs/inch)
#6-32 screw	3	6 ± 0.2

- 1 Complete the procedure listed in After working inside your system.

## Removing OCP card from slot 3

- 1 Ensure that you read the Safety instructions.
  - 2 Complete the procedure listed in Before working inside your system.
  - 3 Remove the mezzanine card.
- 1 Remove the securing screws from the slot cover.
  - 2 Remove the slot cover.

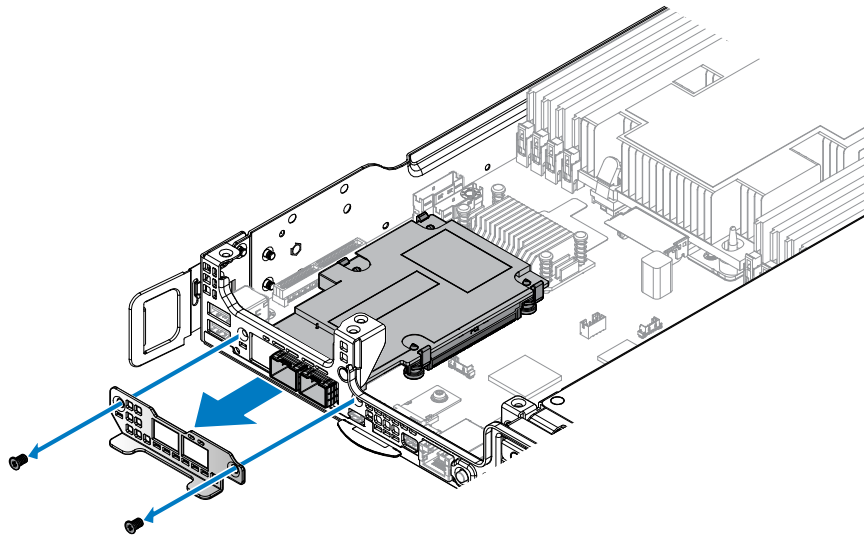

**Figure 119. Removing the slot cover**

- 3 Release the hooks locked on the OCP card.
- 4 Grasp the back of the OCP card and tilt upward. Do not lift the back of the OCP card completely to prevent damage to the components and I/O ports on the front.
- 5 Pull the OCP card back to release the I/O ports from the chassis, and lift the OCP card out to remove.

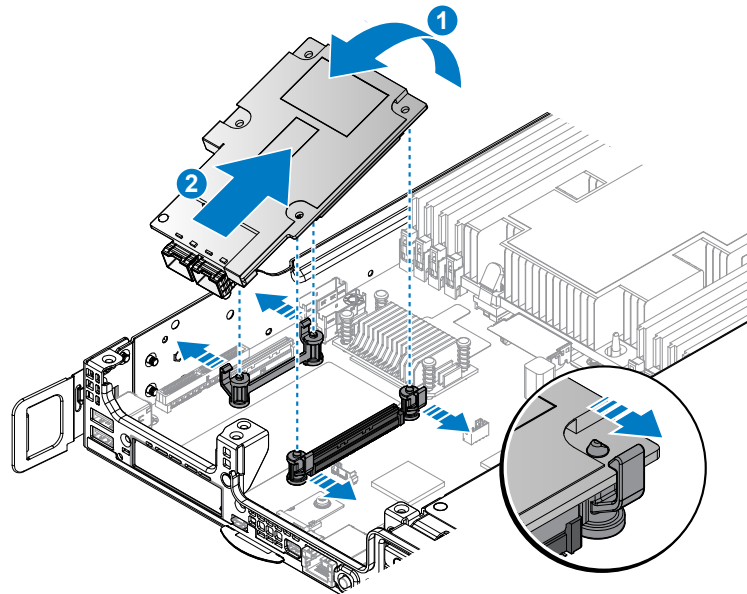
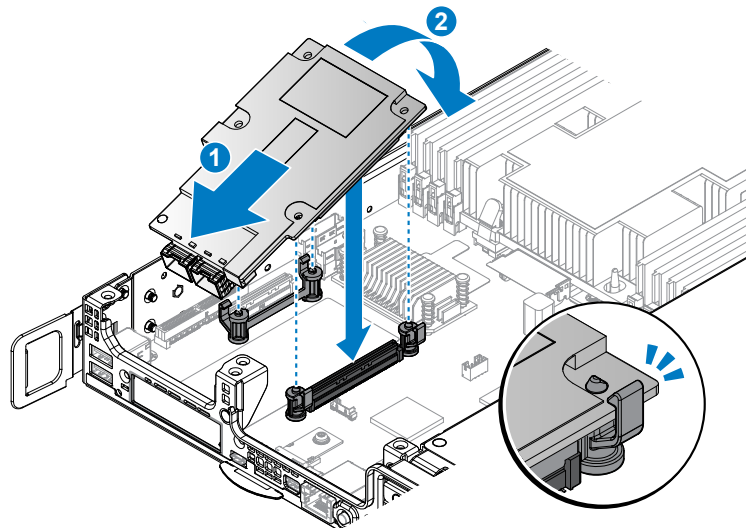

**Figure 120. Removing the OCP card**

- 1 Install the OCP card.
- 2 Install the mezzanine card.
- 3 Complete the procedure listed in After working inside your system.

## Installing OCP card into slot 3

- 1 Ensure that you read the Safety instructions.
  - 2 Complete the procedure listed in Before working inside your system.
- 1 Align the I/O ports on the OCP card with the front of the server.
  - 2 Angle the OCP card into the I/O ports. Make sure the ports on the OCP card are seated correctly in the chassis.
  - 3 Gently lower the OCP card and press the OCP card into the server board connector until it is fully seated.



**Figure 121. Installing the OCP card**

- 4 Align the slot cover with the chassis.
- 5 Secure the slot cover with the provided screws.

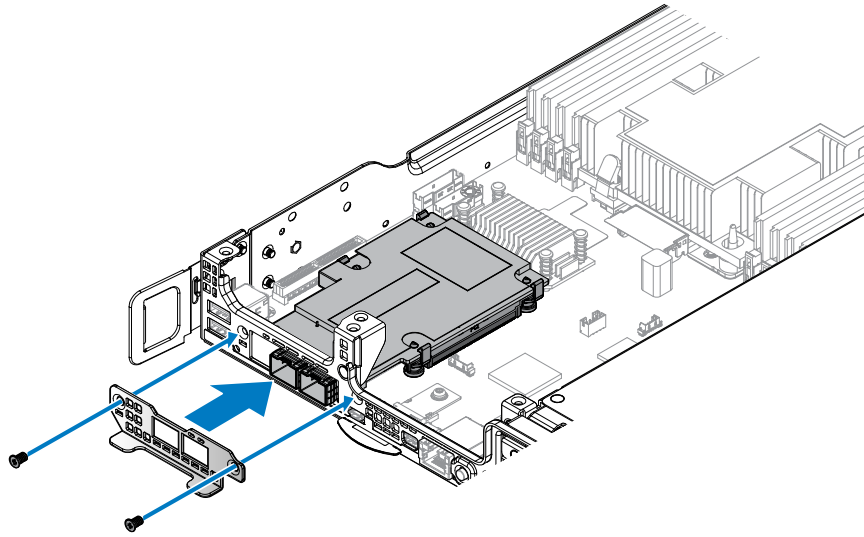

Figure 122. Installing the slot cover

Table 69. Assembly material

Description	Quantity	Torque (lbs/inch)
#6-32 screw	2	6 ± 0.2

- 1 Install the mezzanine card.
- 2 Complete the procedure listed in After working inside your system.

## 3M riser card

### Removing 3M riser card

- 1 Ensure that you read the Safety instructions.
- 2 Complete the procedure listed in Before working inside your system.
- 3 Remove the mezzanine card.
  - 1 Remove the securing screws from the front 3M riser assembly.
  - 2 Remove the front 3M riser assembly from the chassis.

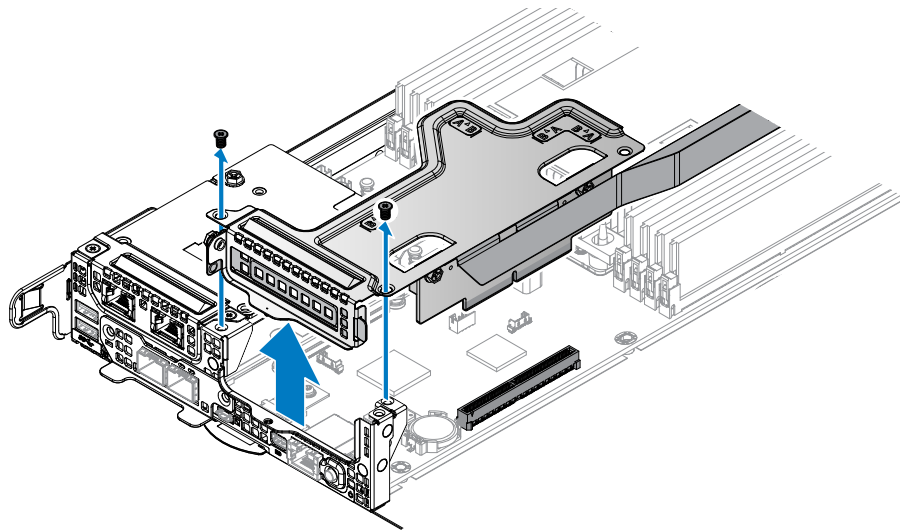

**Figure 123. Removing the front 3M riser assembly**

- 3 Remove the securing screws from the 3M riser card.
- 4 Remove the 3M riser card from the riser bracket.

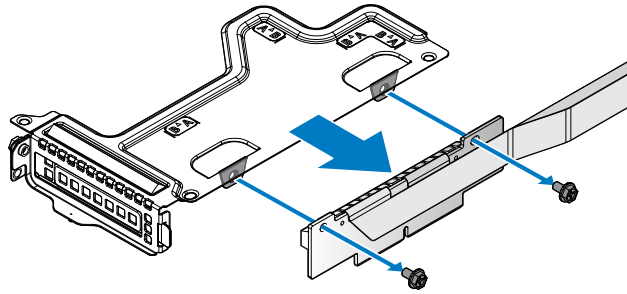

**Figure 124. Removing the front 3M riser card**

- 5 Loosen the captive screw securing the rear 3M riser card.
- 6 Unlock the hook from the rear 3M riser card and remove the rear 3M riser card from the server board.

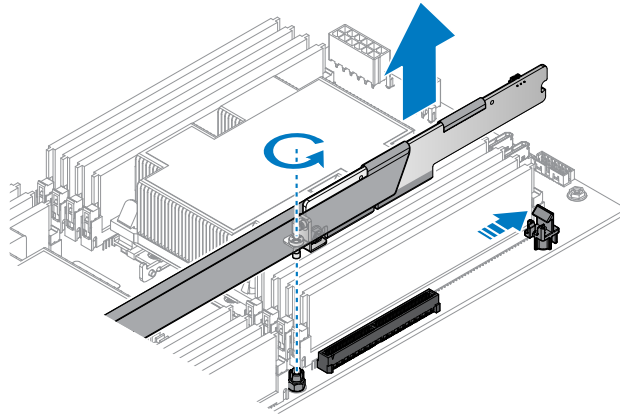

**Figure 125. Removing the front 3M riser card**

- 7 Remove the securing screws from the PCIe bracket.
- 8 Remove the rear 3M riser card (located in slot 5) from the PCIe bracket.

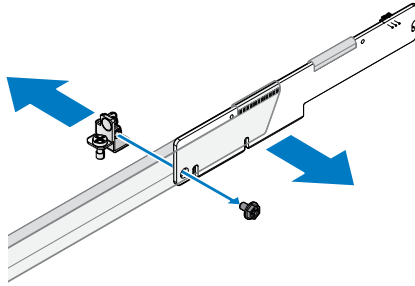

**Figure 126. Removing the PCIe bracket**

- 1 Install the 3M riser card.
- 2 Complete the procedure listed in After working inside your system.
- 3 Install any device drivers needed for the card as described in the documentation for the card.

## Installing 3M riser card

- 1 Ensure that you read the Safety instructions.
- 2 Read and understand the cable routing plan in Cable routing overview.
- 3 Complete the procedure listed in Before working inside your system.

### Cable routing overview

The following routing plan is available for the 3M riser card installation. To ensure correct cable position see Figure 128 for further details.

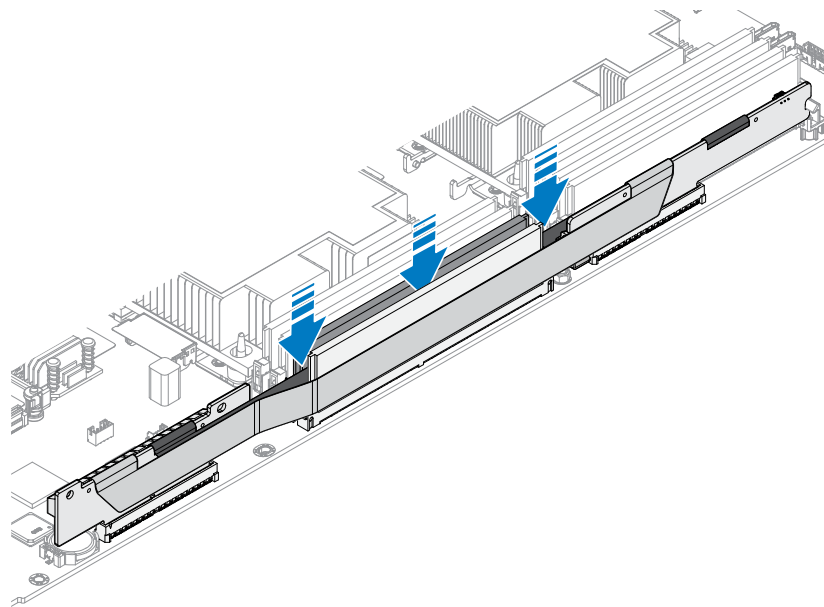
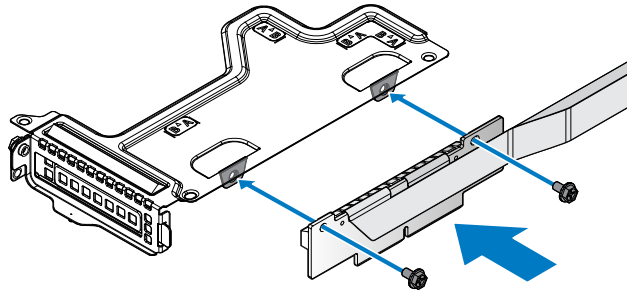

**Figure 127. Cable routing overview**

- 1 Remove the screws securing the riser bracket.
- 2 Remove the riser bracket from the chassis.

**NOTE:** The PCIe bracket is customized for this system. Retain the bracket if replacing with a new PCIe card.

- 3 Align the holes on riser board with the holes on riser bracket.
- 4 Secure the riser board with screws.

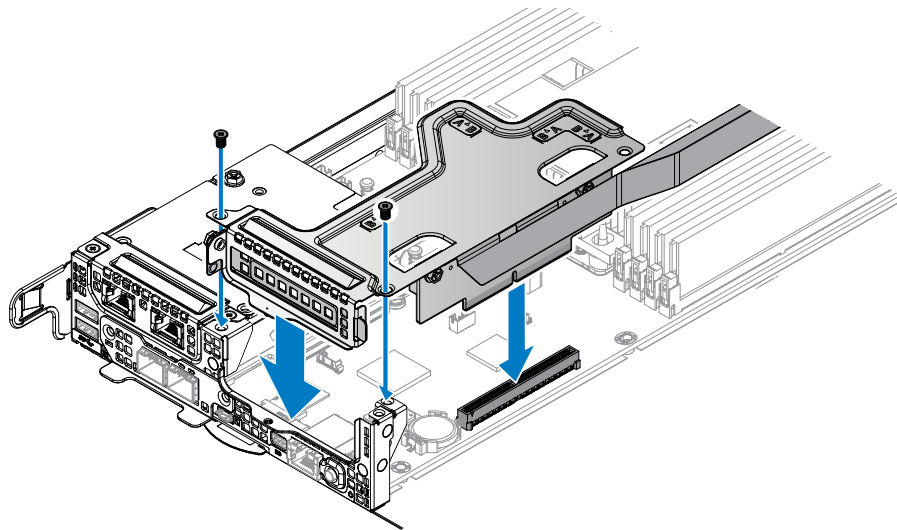

**Figure 128. Installing the front 3M riser card on a bracket**

**Table 70. Assembly material**

Description	Quantity	Torque (lbs/inch)
#6-32 screw	2	6 ± 0.2

- 5 Align the front 3M riser assembly with the screw posts on the chassis and the slot 4 connector on the server board.
- 6 Press the front 3M riser assembly into the server board connector until it is fully seated.
- 7 Secure the front 3M riser assembly with the provided screws.

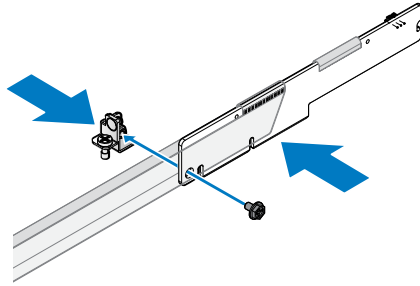

**Figure 129. Installing the front 3M riser assembly**

**Table 71. Assembly material**

Description	Quantity	Torque (lbs/inch)
#6-32 screw	2	6 ± 0.2

- 8 Align the PCIe bracket with the rear 3M riser card.
- 9 Secure the PCIe bracket with the provided screws.

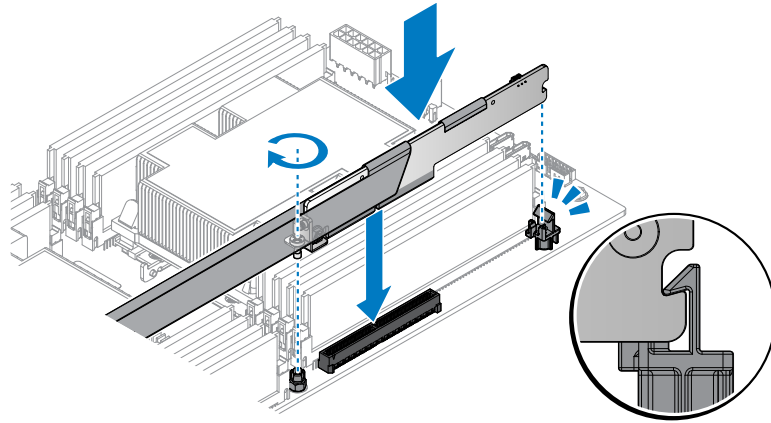

**Figure 130. Installing the PCIe bracket**

**Table 72. Assembly material**

Description	Quantity	Torque (lbs/inch)
M3 screw	1	6 ± 0.2

- 10 Align the rear 3M riser card with the slot 5 connector on the server board.
- 11 Press the rear 3M riser card into the server board connector until it is fully seated. Make sure the hook is locked the rear 3M riser card.
- 12 Tighten the captive screw on the PCIe bracket.



**Figure 131. Installing the rear 3M riser card**

- 1 Follow the procedure listed in the After working inside your system.
- 2 Install any device drivers needed for the card as described in the documentation for the card.

## NPIO card

### Removing NPIO card from the rear bay

**⚠ CAUTION:** Many repairs may only be done by a certified service technician. You should only perform troubleshooting and simple repairs as authorized in your product documentation, or as directed by the online or telephone service and support team. Damage due to servicing that is not authorized by Dell is not covered by your warranty. Read and follow the safety instructions that are shipped with your product.

- 1 Follow the safety guidelines listed in the Safety instructions section.
- 2 Follow the procedure listed in the Before working inside your system section.
  - 1 Disconnect the cables from the NPIO card assembly.
  - 2 Loosen the thumb screws.
  - 3 Remove the NPIO card assembly from the chassis.

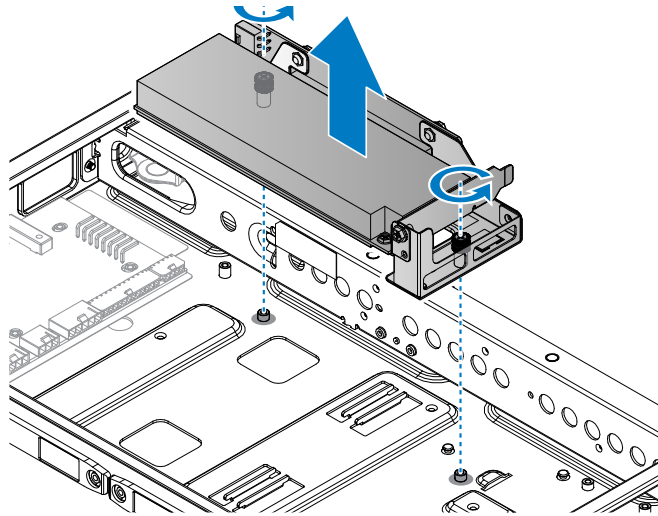

**Figure 132. Removing the NPIO card assembly**

- 4 Remove the securing screw from the NPIO card assembly.
- 5 Remove the NPIO card from the riser board.

**NOTE:** You must install an expansion card filler cover over an empty expansion slot to maintain Federal Communications Commission (FCC) certification of the system. The covers also keep dust and dirt out of the system and aid in proper cooling and airflow inside the system.

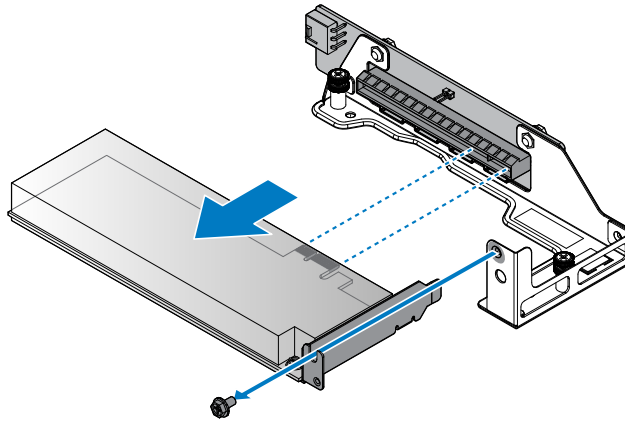

**Figure 133. Removing the NPIO card**

- 6 Remove the securing screws from the riser board.
- 7 Remove the riser board from the riser bracket.

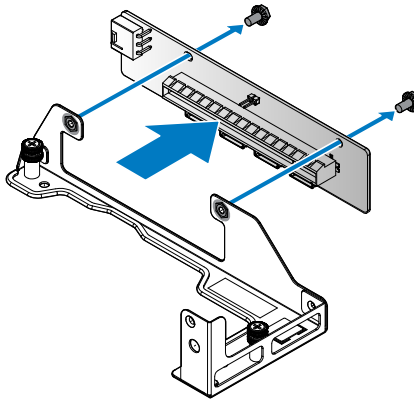

**Figure 134. Removing the riser board**

- 1 Install the NPIO card.
- 2 Complete the procedure listed in After working inside your system.
- 3 Install any device drivers needed for the card as described in the documentation for the card.

## Installing NPIO card in the rear bay

- 1 Follow the procedure listed in the After working inside your system.
- 2 Complete the procedure listed in Before working inside your system.
- 1 Remove the screws securing the riser bracket.
- 2 Remove the riser bracket from the chassis.

**NOTE:** The PCIe bracket is customized for this system. Retain the bracket if replacing a new PCIe card for use with the new PCIe card.

- 3 Align the holes on riser board with the holes on riser bracket.
- 4 Secure the riser board with screws.

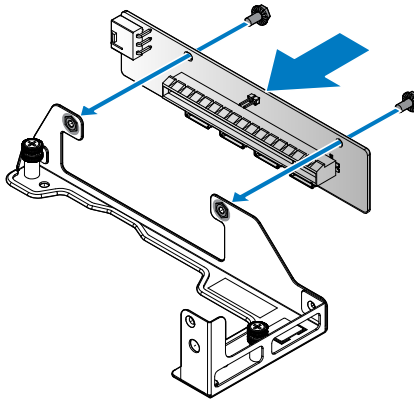

Figure 135. Installing the riser board on a bracket

Table 73. Assembly material

Description	Quantity	Torque (lbs/inch)
#6-32 screw	2	6 ± 0.2

- 5 Align the NPIO card with the riser bracket and the riser board connector.
- 6 Insert the NPIO card in the connector on the riser board.
- 7 Secure the NPIO card with the provided screw.

**NOTE:** You must install an expansion card filler cover over an empty expansion slot to maintain Federal Communications Commission (FCC) certification of the system. The covers also keep dust and dirt out of the system and aid in proper cooling and airflow inside the system.

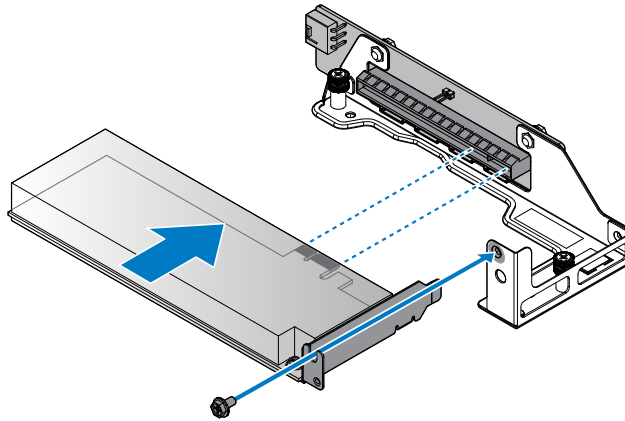
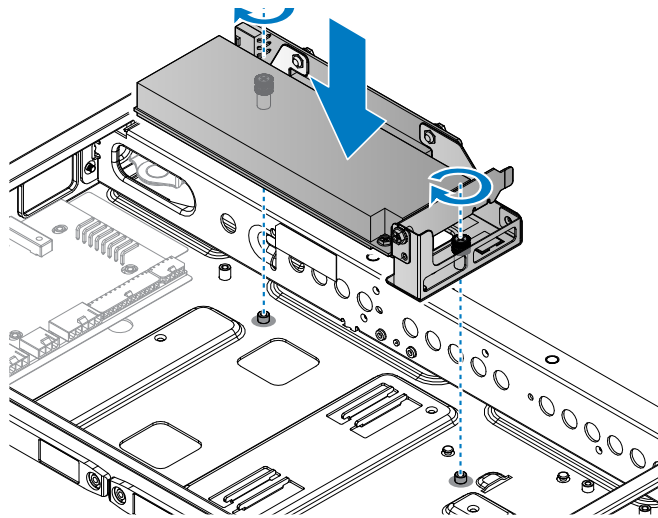

**Figure 136. Installing the NPIO card in a bracket**

**Table 74. Assembly material**

Description	Quantity	Torque (lbs/inch)
#6-32 screw	1	6 ± 0.2

- 8 Align the NPIO card assembly with the screw posts on the chassis and the connector on the server board.
- 9 Press the NPIO card assembly into the server board connector until it is fully seated.
- 10 Secure the NPIO card assembly with the provided screws.

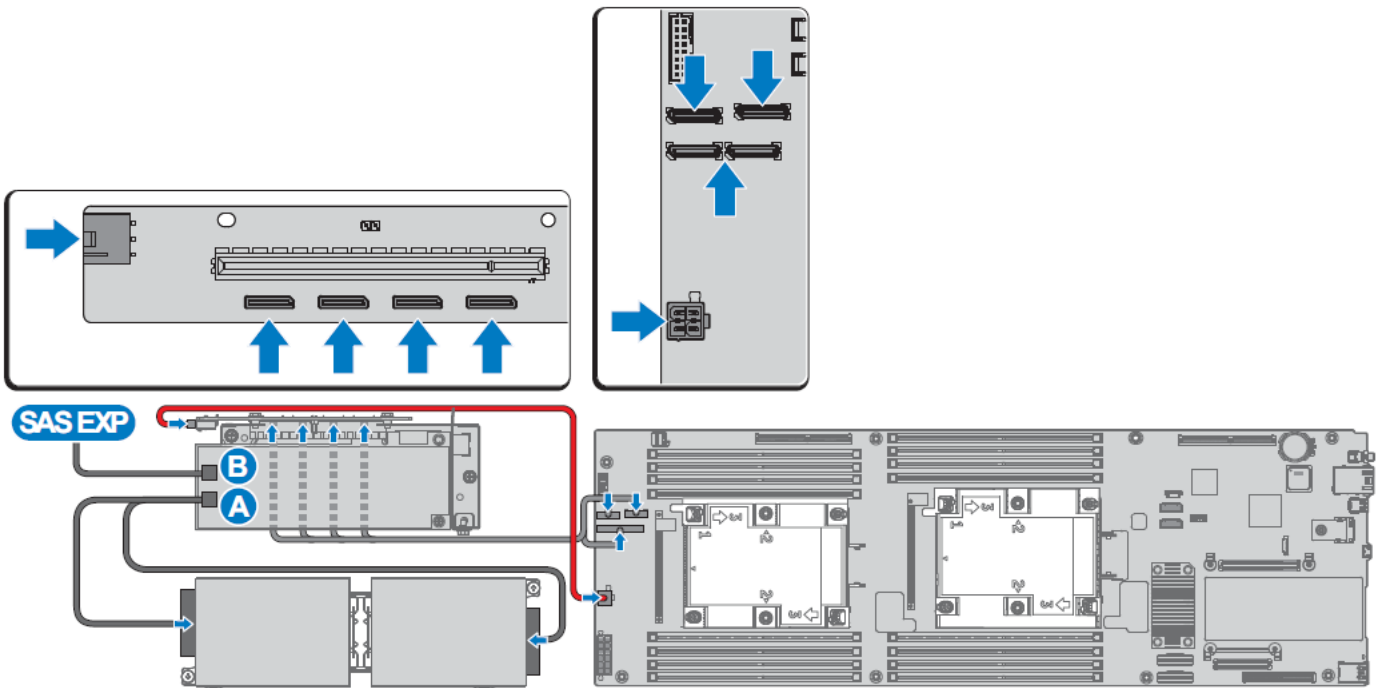

**Figure 137. Installing the NPIO card assembly**

**Table 75. Assembly material**

Description	Quantity	Torque (lbs/inch)
#6-32 screw	2	6 ± 0.2

- 11 Connect the cables to the NPIO card assembly.



**Figure 138. Connecting the cables**

- 1 Follow the procedure listed in the After working inside your system.
- 2 Install any device drivers needed for the card as described in the documentation for the card.

## Node power distribution board(NPDB)

### Removing NPDB

- 1 Ensure that you read the Safety instructions.
  - 2 Complete the procedure listed in Before working inside your system.
- 1 Disconnect all cables from the NPDB.
  - 2 Remove the securing screw from the NPDB.
  - 3 Lift the NPDB to remove from the chassis.

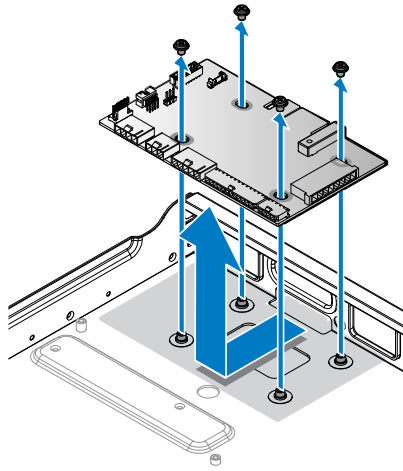

**Figure 139. Removing the NPDB**

- 1 Install the NPDB.
- 2 Complete the procedure listed in After working inside your system.

## Installing NPDB

Ensure that you read the Safety instructions.

- 1 Align the screw holes on the NPDB to the screw posts on the chassis.
- 2 Lower the NPDB in place.
- 3 Secure the NPDB with the screws.

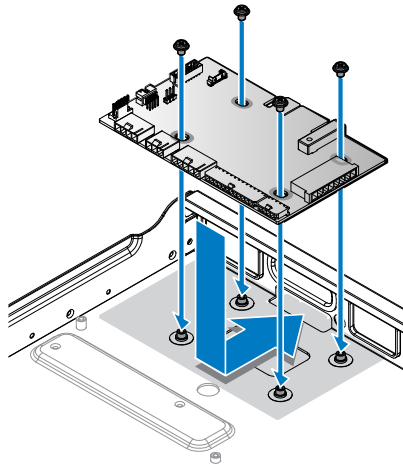
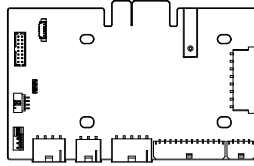

**Figure 140. Installing the NPDB**

**Table 76. Assembly material**

Description	Quantity	Torque (lbs/inch)
#6-32 screw	4	6 ± 0.2

- 4 Connect all cables from the server to the NPDB.



**Figure 141. NPDB overview**

- 1 Complete the procedure listed in After working inside your system.

## Hard drive backplane

### Removing HDD backplane

- 1 Ensure that you read the Safety instructions.
- 2 Complete the procedure listed in Before working inside your system.
- 3 Remove the 3.5-inch or 2.5-inch hot swappable HDDs.
- 1 Pull up the latches on each side to release and remove the plastic clip at the top of HDD backplane.

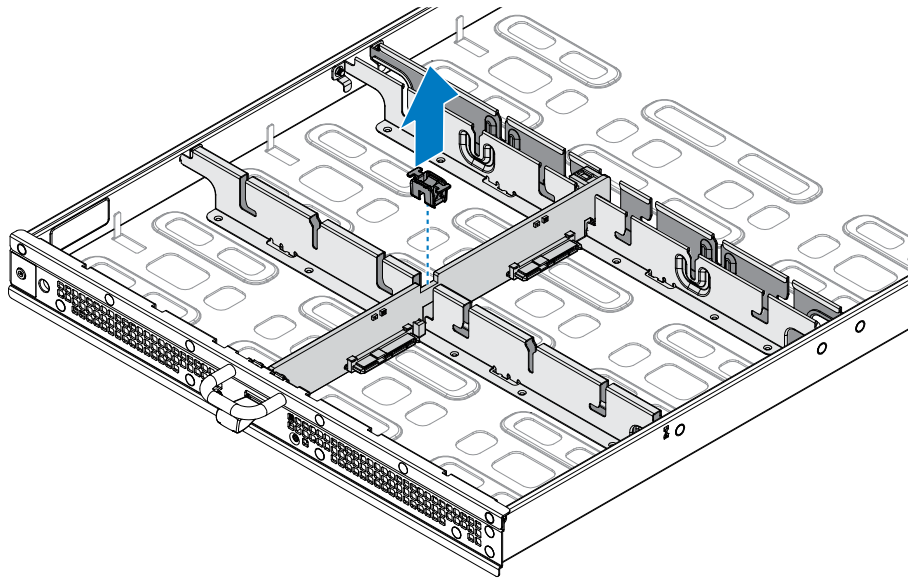

**Figure 142. Removing the plastic clip**

- 2 Disconnect the power or signal cable connectors from both sides of the HDD backplane.
- 3 Lift up the HDD backplane to remove from the chassis.

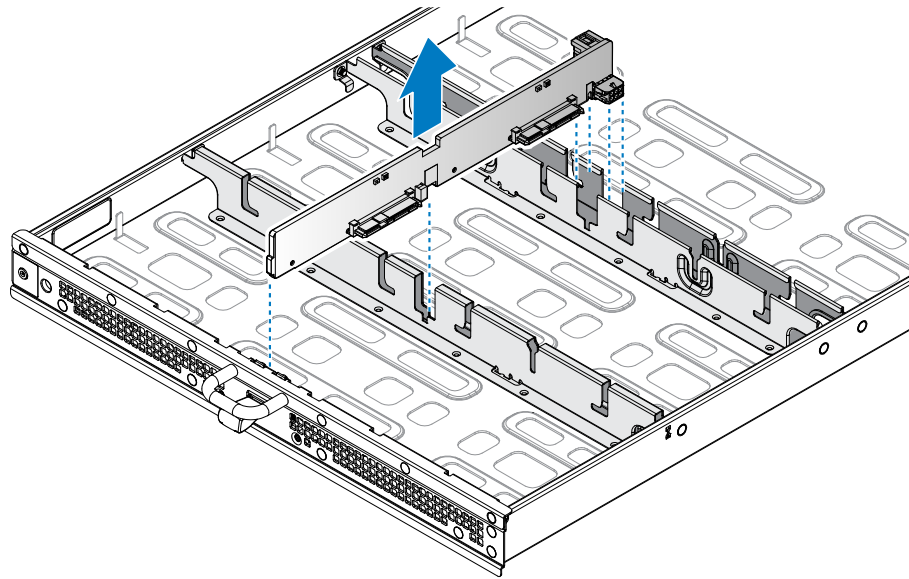
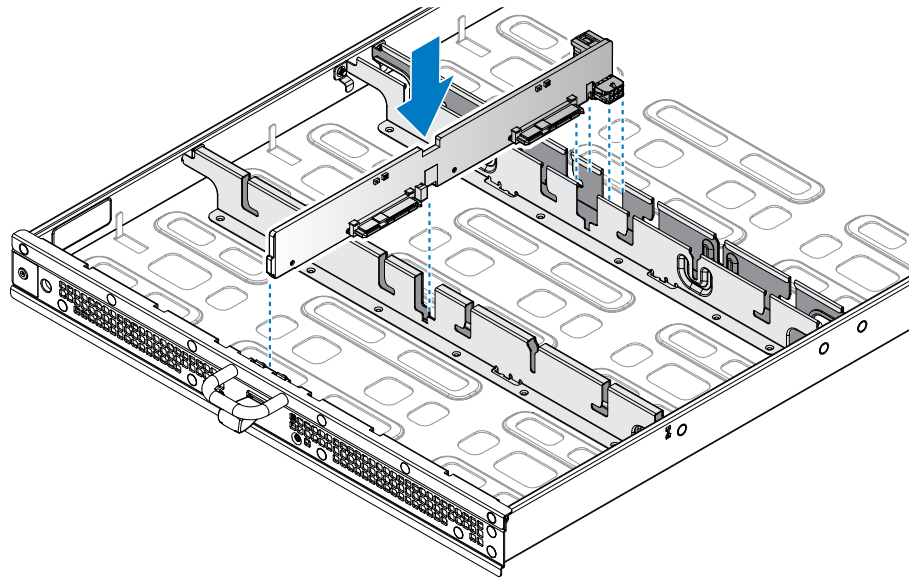

**Figure 143. Removing the HDD backplane**

- 1 Install the HDD backplane.
- 2 Complete the procedure listed in After working inside your system.

## Installing HDD backplane

- 1 Ensure that you read the Safety instructions.
  - 2 Complete the procedure listed in Before working inside your system.
- 1 Align the HDD backplane over the chassis making sure the HDD connection slots on the backplane are positioned on the bottom.
  - 2 Slide the HDD backplane in place and press down to seat the backplane properly.



**Figure 144. Installing the HDD backplane**

- 3 Install the plastic clip over the HDD backplane and chassis brace.
- 4 Press down on the locking latches to secure the HDD backplane on the chassis.

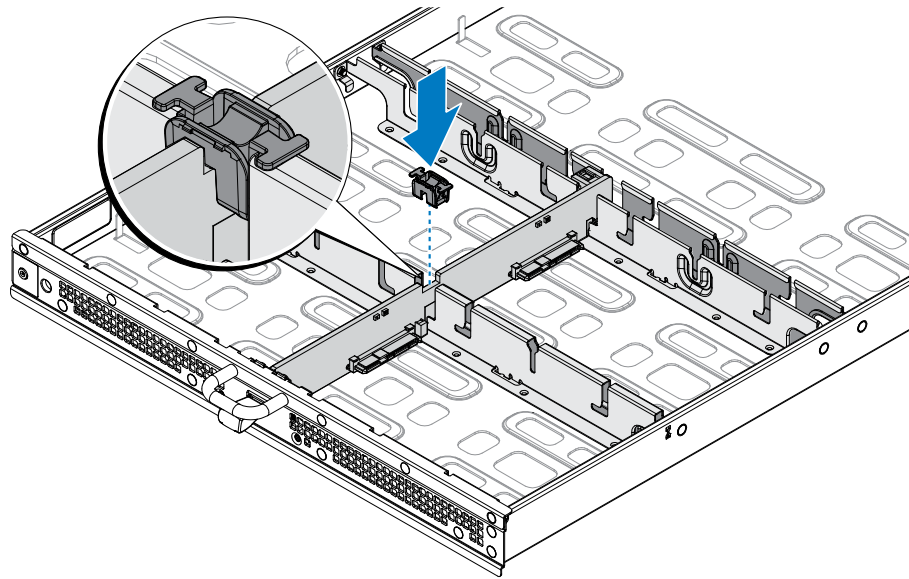

**Figure 145. Installing the plastic clip**

- 1 Install the 3.5-inch or 2.5-inch hot swappable HDD.
- 2 Complete the procedure listed in After working inside your system.

## SAS expander board

### Removing SAS expander board

- 1 Ensure that you read the Safety instructions.
  - 2 Complete the procedure listed in Before working inside your system.
- 1 Remove the screw securing the SAS expander board.
  - 2 Slide the SAS expander board as shown in the figure.
  - 3 Remove the SAS expander board.

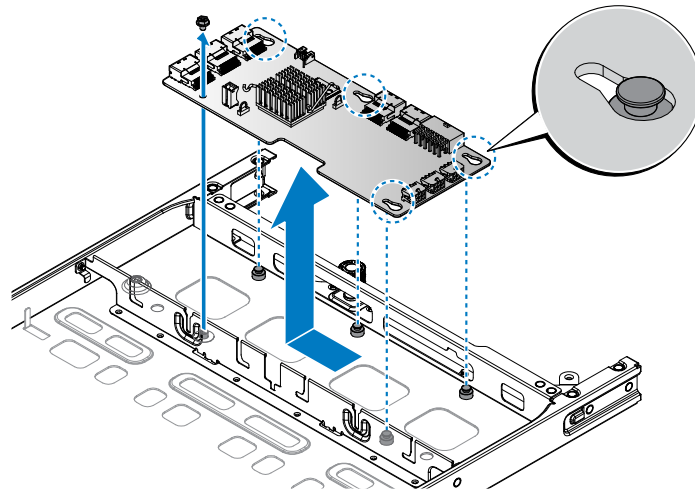

**Figure 146. Removing the SAS expander board**

- 1 Install the SAS expander board.
- 2 Complete the procedure listed in After working inside your system.

## Installing SAS expander board

- 1 Ensure that you read the Safety instructions.
  - 2 Complete the procedure listed in Before working inside your system.
- 1 Align the locking wells on the SAS expander board to the locking posts on the chassis.
  - 2 Install the SAS expander board and slide as shown in the following illustration.
  - 3 Secure with the provided screw.

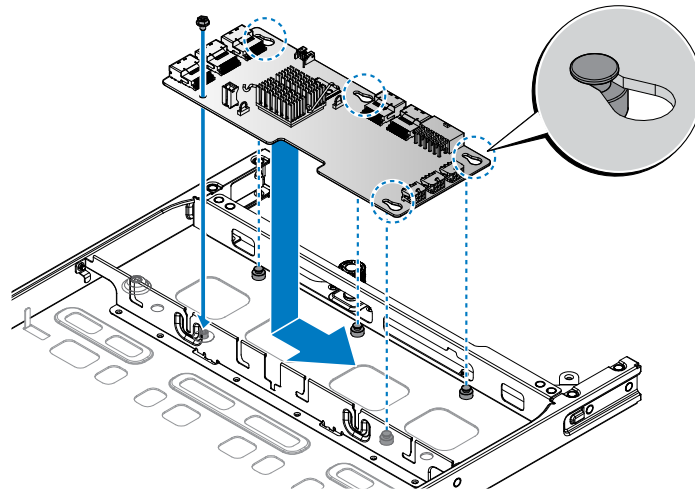

Figure 147. Installing the SAS expander board

Table 77. Assembly material

Description	Quantity	Torque (lbs/inch)
#6-32 screw	1	6 ± 0.2

- 1 Complete the procedure listed in After working inside your system.

## Cable management arm

### Removing CMA in the hard drive tray

- 1 Ensure that you read the Safety instructions.
  - 2 Complete the procedure listed in Before working inside your system.
  - 3 Remove the 3.5-inch or 2.5-inch hot swappable HDDs.
- 1 Locate the power cable connecting the CMA to the NPDB. Disconnect it from the NPDB.
  - 2 Locate the signal cables connected to the PCIe raid or Mini PERC slot, see your specific configuration for the connection type. Disconnect the signal cable from the slot.

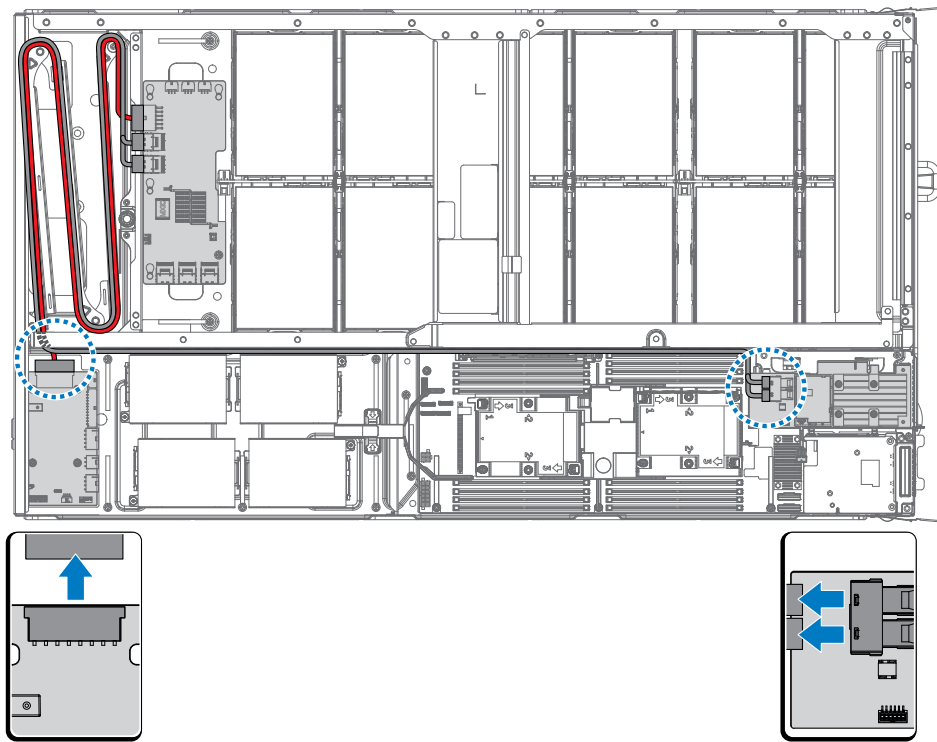

**Figure 148. Disconnect the cables**

- 3 Locate the screw securing the CMA to the rear of the chassis and remove it.
- 4 Gently move back the CMA and pull out the cables from the server board side of the chassis. The cables should now be on the tray side of the chassis.
- 5 Remove the CMA screw connected to the rear of the hard drive tray.
- 6 Disconnect the cables from the SAS expander board and pull them out of the hard drive tray.
- 7 Remove the CMA from the chassis. Make sure the cable ends do not catch on any components during removal to avoid damaging the server or the cables.

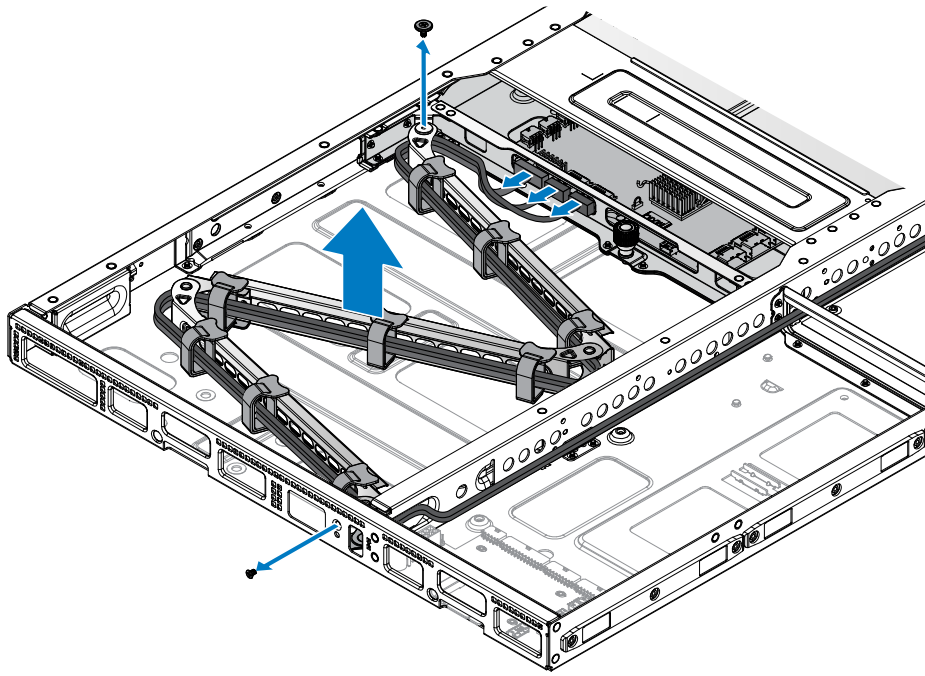
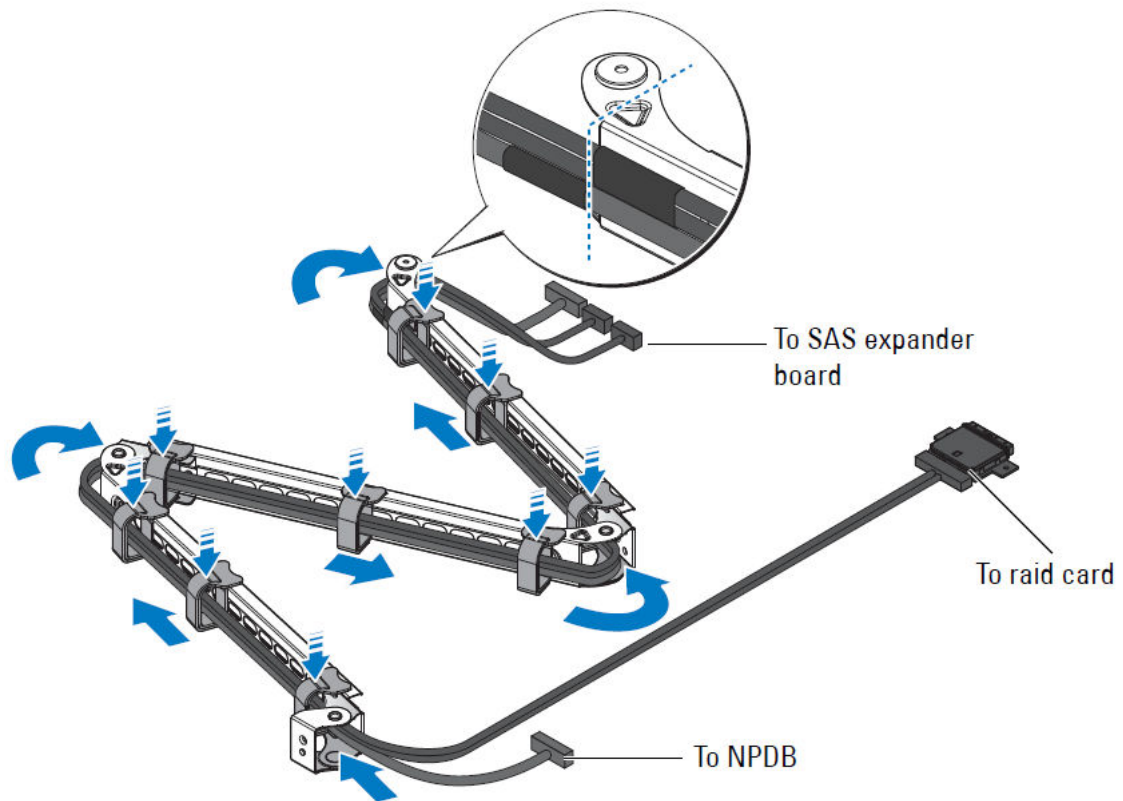

**Figure 149. Removing the CMA in the hard drive tray**

- 1 Install the CMA.
- 2 Complete the procedure listed in After working inside your system.

## Installing CMA in the hard drive tray

- 1 Ensure that you read the Safety instructions.
- 2 Complete the procedure listed in Before working inside your system.
- 1 Orient the CMA assembly as shown in Figure XX.



**Figure 150. Completed CMA assembly**

**NOTE:** Make sure the soft side (loops) is facing the cables to prevent damage to the cables.

- 2 Insert the SAS expander end through the rear of the hard drive tray and align with the connectors on the SAS expander board.
- 3 Attach the end of the CMA arm over the flange on the supporting wall and insert the CMA screw.
- 4 Grasp the cables on the remaining side and run them through the middle wall of the chassis.
- 5 Align the CMA arm with the screw hole on the rear of the chassis.

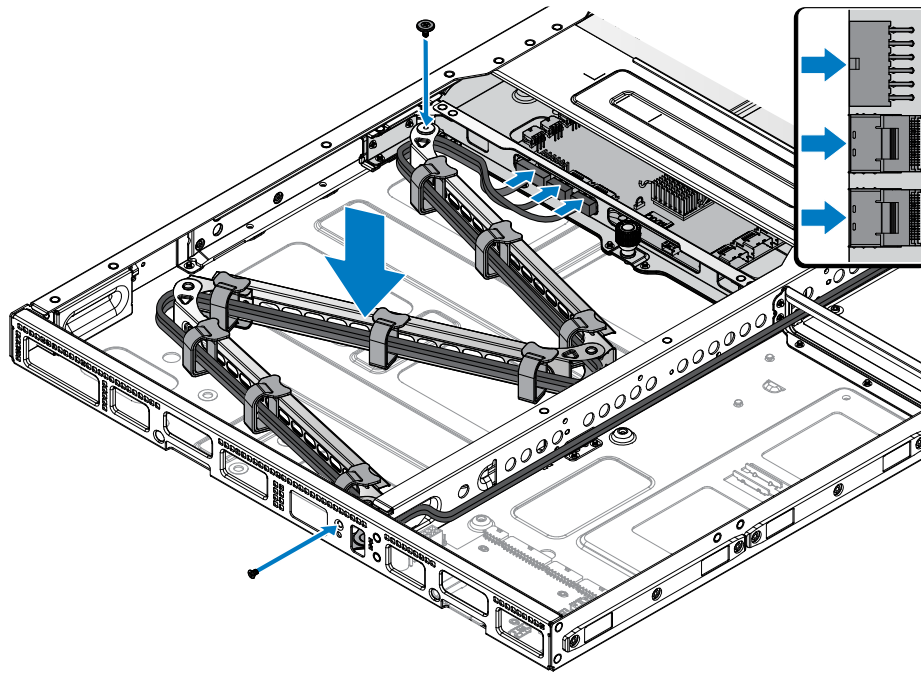

**Figure 151. Removing a CMA in a hard drive tray**

**Table 78. Assembly material**

Description	Quantity	Torque (lbs/inch)
#6-32 screw	1	6 ± 0.2

- 6 Connect the signal cable to either the PCIe raid or Mini PERC slots. This step is dependent on the specific configuration.
- 7 Connect the power cable to the NPDB.
- 1 Install the 3.5-inch or 2.5-inch hot swappable HDD.
- 2 Complete the procedure listed in After working inside your system.

# Using system diagnostics

If you experience a problem with your system, run the system diagnostics before contacting Dell for technical assistance. The purpose of running system diagnostics is to test your system hardware without using additional equipment or risking data loss. If you are unable to fix the problem yourself, service and support personnel can use the diagnostics results to help you solve the problem.

## Dell Embedded System Diagnostics

**NOTE:** The Dell Embedded System Diagnostics is also known as Enhanced Pre-boot System Assessment (ePSA) diagnostics.

The Embedded System Diagnostics provides a set of options for particular device groups or devices allowing you to:

- Run tests automatically or in an interactive mode
- Repeat tests
- Display or save test results
- Run thorough tests to introduce additional test options to provide extra information about the failed device(s)
- View status messages that inform you if tests are completed successfully
- View error messages that inform you of problems encountered during testing

## Running the Embedded System Diagnostics from Boot Manager

Run the Embedded System Diagnostics (ePSA) if your system does not boot.

- 1 When the system is booting, press F10.
- 2 Use the up arrow and down arrow keys to select **System Utilities > Launch Diagnostics**.

The ePSA Pre-boot System Assessment window is displayed, listing all devices detected in the system. The diagnostics starts executing the tests on all the detected devices.

## Running Embedded System Diagnostics from Lifecycle Controller

- 1 As the system boots, press F10.
- 2 Select **Hardware Diagnostics > Run Hardware Diagnostics**.

The **ePSA Pre-boot System Assessment** window is displayed, listing all devices detected in the system. The diagnostics starts executing the tests on all the detected devices.

# System diagnostic controls

Table 79. System diagnostic controls

Menu	Description
Configuration	Displays the configuration and status information of all detected devices.
Results	Displays the results of all tests that are run.
System health	Provides the current overview of the system performance.
Event log	Displays a time-stamped log of the results of all tests run on the system. This is displayed if at least one event description is recorded.

## Jumpers and connectors

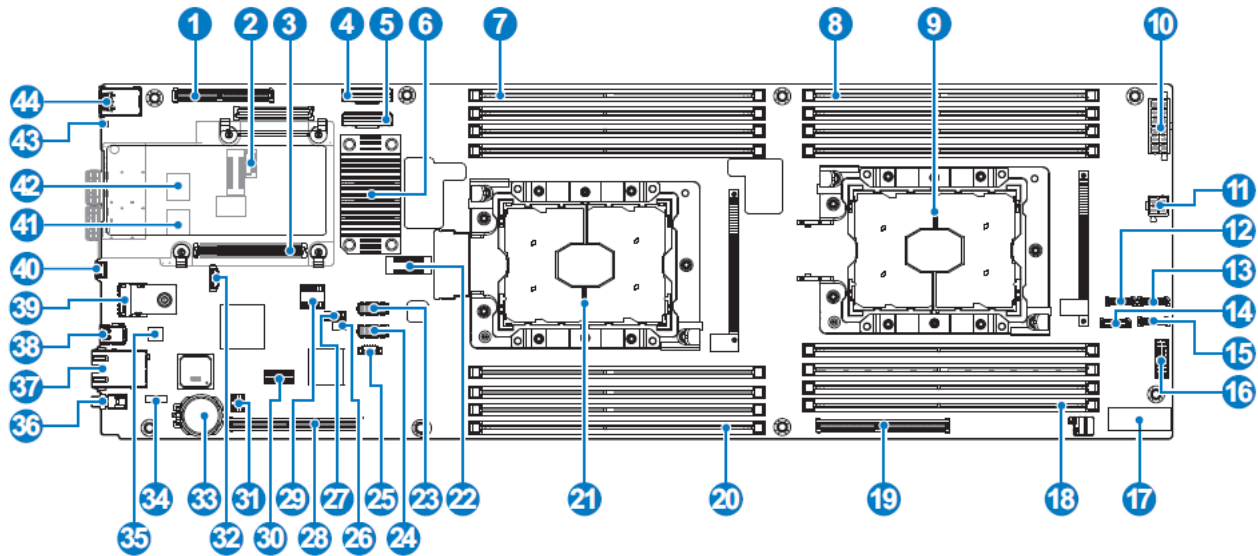

Figure 152. Jumpers and connectors

Table 80. Jumpers and connectors description

No.	Description	Location	No.	Description	Location
1	Mezzanine slot	J_DCS_MEZZ	23	CPU 1 HIF sideband connector	J_HFI1
2	Internal TTL COM port	J_BMC_COM2	24	CPU 2 HIF sideband connector	J_HFI2
3	OCP A + B connector	J_OCP_A, J_OCP_B	25	PMBUS connector	J_PMBUS
4	SATA x8 connector	SATA1	26	CPLD JTAG connector	J_CPLD_JTAG
5	SATA x6 connector	SATA2	27	Internal USB connector	INTERNAL_USB1
6	Lewisburg-2	U_LBG	28	PCIe x16 main riser connector	J_PCIE_RISER
7	DIMM slot CPU 1		29	BIOS socket	U_SPI_BIOS_SKT
8	DIMM slot CPU 2		30	SPIVU debug connector	J_SPIVU1
9	CPU 2	J_CPU2_A, J_CPU2_B	31	iDRAC uboot SPI socket	U_BMC_SPI_SKT
10	G5 power connector	J_G5_PWR	32	G5 LAN management connector	G5_MGMT

No.	Description	Location	No.	Description	Location
11	G5 HDD power connector	PWR_HDV1	33	Battery socket	BAT1
12	NVMe connector	J_NMVE_A2	34	Internal BMC UART connector	J_BMC_UART
13	NVMe connector	J_NMVE_A1	35	Intel i350 GbE LAN controller	U_LOM1
14	NVMe connector	J_NMVE_B2	36	Power button	SW1
15	NVMe connector	J_NMVE_B1	37	Shared RJ-45 connector	RJ45
16	G5 control connector	J_G5_CTRL	38	Mini DP connector	DP_PORT
17	Interposer connector	J_INTERPOSESR	39	TPM socket	TPM
18	DIMM slot CPU 2		40	iDRAC management USB	DEBUG_USB1
19	PCIe x16 buried riser connector	J_M2_RISER	41	SFP+ connector 2	SFP2
20	DIMM slot CPU 1		42	SFP+ connector 1	SFP1
21	CPU 1		43	UID LED	LED3
22	Merge XDP	MERGE_XDP	44	Dual USB 3.0 connector	J_USB3

# Troubleshooting your system

## Troubleshooting list

Table 81. Troubleshooting list

Issue description	Root cause	Troubleshooting step
KVM test failure	Incompatible brand: ATEN/cs1758	Suggested KVM types: <ul style="list-style-type: none"><li data-bbox="1038 674 1219 701">· ATEN/cs1308</li><li data-bbox="1038 707 1230 735">· ATEN/cs1732b</li></ul>

## Getting help

### Contacting Dell

Dell provides several online and telephone based support and service options. If you do not have an active internet connection, you can find contact information about your purchase invoice, packing slip, bill, or Dell product catalog. Availability varies by country and product, and some services may not be available in your area. To contact Dell for sales, technical assistance, or customer service issues:

- 1 Go to <http://Dell.com/support>.
- 2 Select your country from the drop-down menu on the lower right corner of the page.
- 3 For customized support:
  - a Enter your system Service Tag in the **Enter your Service Tag** field.
  - b Click **Submit**.The support page that lists the various support categories is displayed.
- 4 For general support:
  - a Select your product category.
  - b Select your product segment.
  - c Select your product.The support page that lists the various support categories is displayed.
- 5 For contact details of Dell Global Technical Support:
  - a Click **Global Technical Support**.
  - b The **Contact Technical Support** page is displayed with details to call, chat, or e-mail the Dell Global Technical Support team.

### Documentation feedback

You can rate the documentation or write your feedback on any of our Dell documentation pages and click **Send Feedback** to send your feedback.