

ChengMing 3990

Service Manual

Notes, cautions, and warnings

 **NOTE:** A NOTE indicates important information that helps you make better use of your product.

 **CAUTION:** A CAUTION indicates either potential damage to hardware or loss of data and tells you how to avoid the problem.

 **WARNING:** A WARNING indicates a potential for property damage, personal injury, or death.

Chapter 1: Working on your computer	5
Safety instructions.....	5
Before working inside your computer.....	5
Safety precautions.....	6
Electrostatic discharge—ESD protection.....	7
ESD Field Service kit	7
Transporting sensitive components.....	8
After working inside your computer.....	8
Chapter 2: Technology and components	9
USB features.....	9
HDMI 1.4- HDMI 2.0.....	10
Chapter 3: Disassembly and reassembly	11
Cover.....	11
Removing the side cover.....	11
Installing the cover.....	13
Front Bezel.....	14
Removing the front bezel.....	14
Installing the front bezel.....	15
Hard drive.....	16
2.5 inch hard drive	16
3.5 inch hard drive	20
Fan assembly.....	21
Removing the fan assembly.....	21
Installing the fan assembly.....	22
Optical drive.....	23
Removing the optical drive	23
Installing the optical drive.....	25
M.2 SSD card.....	25
Removing the M.2 SSD card.....	25
Installing the M.2 SSD card.....	27
Power supply unit.....	27
Removing the power supply unit	27
Installing the power supply unit	30
Speaker.....	31
Removing the speaker.....	31
Installing the speaker.....	33
Heat sink assembly.....	33
Removing the heat sink assembly.....	33
Installing the heat sink assembly.....	35
Memory modules.....	35
Removing the memory module.....	35
Installing the memory module.....	37

Expansion card.....	37
Removing the expansion card.....	37
Installing the expansion card.....	39
WLAN module.....	40
Removing the WLAN module.....	40
Installing the WLAN module.....	41
Coin-cell battery.....	42
Removing the coin cell battery.....	42
Installing the coin cell battery.....	43
Processor.....	43
Removing the processor.....	43
Installing the processor.....	45
System board.....	46
Removing the system board.....	46
Installing the system board.....	48
Chapter 4: System setup.....	51
BIOS overview.....	51
Entering BIOS Setup.....	51
Navigation keys.....	51
F12 One Time Boot menu.....	52
Boot Sequence.....	52
System Setup options.....	52
Updating the BIOS.....	58
Updating the BIOS in Windows.....	58
Updating the BIOS in Linux and Ubuntu.....	59
Updating the BIOS using the USB drive in Windows.....	59
Updating the BIOS from the One-Time boot menu.....	60
System and setup password.....	60
Assigning a system setup password.....	61
Deleting or changing an existing system password or setup password.....	61
Clearing system and setup passwords.....	62
Chapter 5: Troubleshooting.....	63
EC Diag LED Behavior	63
Dell Enhanced Pre-Boot System Assessment — ePSA Diagnostic 3.0.....	65
System error messages.....	65
Recovering the operating system.....	65
Real-Time Clock (RTC Reset).....	66
Backup media and recovery options.....	66
Network power cycle.....	66
Chapter 6: Getting help and contacting Dell Technologies.....	67

Working on your computer

Topics:

- [Safety instructions](#)

Safety instructions

Prerequisites

Use the following safety guidelines to protect your computer from potential damage and to ensure your personal safety. Unless otherwise noted, each procedure included in this document assumes that the following conditions exist:

- You have read the safety information that shipped with your computer.
- A component can be replaced or, if purchased separately, installed by performing the removal procedure in reverse order.

About this task

⚠ WARNING: Before working inside your computer, read the safety information that shipped with your computer. For additional safety best practices information, see the [Regulatory Compliance Homepage](#)

⚠ CAUTION: Many repairs may only be done by a certified service technician. You should only perform troubleshooting and simple repairs as authorized in your product documentation, or as directed by the online or telephone service and support team. Damage due to servicing that is not authorized by Dell is not covered by your warranty. Read and follow the safety instructions that came with the product.

⚠ CAUTION: To avoid electrostatic discharge, ground yourself by using a wrist grounding strap or by periodically touching an unpainted metal surface at the same time as touching a connector on the back of the computer.

⚠ CAUTION: Handle components and cards with care. Do not touch the components or contacts on a card. Hold a card by its edges or by its metal mounting bracket. Hold a component such as a processor by its edges, not by its pins.

⚠ CAUTION: When you disconnect a cable, pull on its connector or on its pull-tab, not on the cable itself. Some cables have connectors with locking tabs; if you are disconnecting this type of cable, press in on the locking tabs before you disconnect the cable. As you pull connectors apart, keep them evenly aligned to avoid bending any connector pins. Also, before you connect a cable, ensure that both connectors are correctly oriented and aligned.

ⓘ NOTE: Disconnect all power sources before opening the computer cover or panels. After you finish working inside the computer, replace all covers, panels, and screws before connecting to the power source.

⚠ CAUTION: Exercise caution when handling Lithium-ion batteries in laptops. Swollen batteries should not be used and should be replaced and disposed properly.

ⓘ NOTE: The color of your computer and certain components may appear differently than shown in this document.

⚠ CAUTION: System will shut down if side covers are removed while the system is running. The system will not power on if the side cover is removed.

Before working inside your computer

About this task

To avoid damaging your computer, perform the following steps before you begin working inside the computer.

Steps

1. Ensure that you follow the [Safety instructions](#).
2. Ensure that your work surface is flat and clean to prevent the computer cover from being scratched.
3. If the computer is connected to a docking device (docked), undock it.

 **CAUTION: To disconnect a network cable, first unplug the cable from your computer and then unplug the cable from the network device.**

4. Disconnect all network cables from the computer.
5. Disconnect your computer and all attached devices from their electrical outlets.
6. Close the display and turn the computer upside-down on a flat work surface.

 **NOTE:** To avoid damaging the system board, you must remove the main battery before you service the computer.

7. Remove the main battery.
8. Turn the computer top-side up.
9. Open the display.
10. Press the power button to ground the system board.

 **CAUTION: To guard against electrical shock, always unplug your computer from the electrical outlet before opening the display.**

 **CAUTION: Before touching anything inside your computer, ground yourself by touching an unpainted metal surface, such as the metal at the back of the computer. While you work, periodically touch an unpainted metal surface to dissipate static electricity, which could harm internal components.**

11. Remove any installed ExpressCards or Smart Cards from the appropriate slots.

Safety precautions

The safety precautions chapter details the primary steps to be taken before performing any disassembly instructions.

Observe the following safety precautions before you perform any installation or break/fix procedures involving disassembly or reassembly:

- Turn off the system and all attached peripherals.
- Disconnect the system and all attached peripherals from AC power.
- Disconnect all network cables, telephone, and telecommunications lines from the system.
- Use an ESD field service kit when working inside any tablet/notebook/desktop to avoid electrostatic discharge (ESD) damage.
- After removing any system component, carefully place the removed component on an anti-static mat.
- Wear shoes with non-conductive rubber soles to reduce the chance of getting electrocuted.

Standby power

Dell products with standby power must be unplugged before you open the case. Systems that incorporate standby power are essentially powered while turned off. The internal power enables the system to be remotely turned on (wake on LAN) and suspended into a sleep mode and has other advanced power management features.

Unplugging, pressing and holding the power button for 20 seconds should discharge residual power in the system board. Remove the battery from tablets/notebooks.

Bonding

Bonding is a method for connecting two or more grounding conductors to the same electrical potential. This is done through the use of a field service electrostatic discharge (ESD) kit. When connecting a bonding wire, ensure that it is connected to bare metal and never to a painted or non-metal surface. The wrist strap should be secure and in full contact with your skin, and ensure that you remove all jewelry such as watches, bracelets, or rings prior to bonding yourself and the equipment.

Electrostatic discharge—ESD protection

ESD is a major concern when you handle electronic components, especially sensitive components such as expansion cards, processors, memory modules, and system boards. A slight charge can damage circuits in ways that may not be obvious, such as intermittent problems or a shortened product life span. As the industry pushes for lower power requirements and increased density, ESD protection is an increasing concern.

Two recognized types of ESD damage are catastrophic and intermittent failures.

- **Catastrophic** – Catastrophic failures represent approximately 20 percent of ESD-related failures. The damage causes an immediate and complete loss of device functionality. An example of catastrophic failure is a memory module that has received a static shock and immediately generates a "No POST/No Video" symptom with a beep code that is emitted for missing or nonfunctional memory.
- **Intermittent** – Intermittent failures represent approximately 80 percent of ESD-related failures. The high rate of intermittent failures means that most of the time when damage occurs, it is not immediately recognizable. The memory module receives a static shock, but the tracing is merely weakened and does not immediately produce outward symptoms that are related to the damage. The weakened trace may take weeks or months to melt, and in the meantime may cause degradation of memory integrity, intermittent memory errors, and so on.

Intermittent failures that are also called latent or "walking wounded" are difficult to detect and troubleshoot.

Perform the following steps to prevent ESD damage:

- Use a wired ESD wrist strap that is properly grounded. Wireless anti-static straps do not provide adequate protection. Touching the chassis before handling parts does not ensure adequate ESD protection on parts with increased sensitivity to ESD damage.
- Handle all static-sensitive components in a static-safe area. If possible, use anti-static floor pads and workbench pads.
- When unpacking a static-sensitive component from its shipping carton, do not remove the component from the anti-static packing material until you are ready to install the component. Before unwrapping the anti-static packaging, use the anti-static wrist strap to discharge the static electricity from your body. For more information about the wrist strap and ESD wrist strap tester, see [Components of an ESD Field Service Kit](#).
- Before transporting a static-sensitive component, place it in an anti-static container or packaging.

ESD Field Service kit

The unmonitored field service kit is the most commonly used service kit. Each Field Service kit includes three main components: anti-static mat, wrist strap, and bonding wire.

 **CAUTION: It is critical to keep ESD-sensitive devices away from internal parts that are insulated and often highly charged, such as plastic heat sink casings.**

Working Environment

Before deploying the ESD Field Service kit, assess the situation at the customer location. Before the ESD Field Service kit is deployed, conduct an evaluation of the site to ensure proper setup and readiness. For example, deploying the kit for a server environment is different than for a desktop or laptop environment. Servers are typically installed in a rack within a data center; desktops or laptops are typically placed on office desks or cubicles. Always look for a large open flat work area that is free of clutter and large enough to deploy the ESD kit with additional space to accommodate the type of computer that is being repaired. The workspace should also be free of insulators that can cause an ESD event. On the work area, insulators such as styrofoam and other plastics should always be moved at least 12 inches or 30 centimeters away from sensitive parts before physically handling any hardware components.

ESD Packaging

All ESD-sensitive devices must be shipped and received in static-safe packaging. Metal, static-shielded bags are preferred. However, you should always return the damaged component using the same ESD bag and packaging that the new part arrived in. The ESD bag should be folded over and taped shut and all the same foam packing material should be used in the original box that the new part arrived in. ESD-sensitive devices should be removed from packaging only at an ESD-protected work surface, and parts should never be placed on top of the ESD bag because only the inside of the bag is shielded. Always place parts in your hand, on the anti-static mat, in the computer, or inside an ESD bag.

Components of an ESD Field Service kit

The components of an ESD Field Service kit are:

- **Anti-Static Mat** – The anti-static mat is dissipative and parts can be placed on it during service procedures. When using an anti-static mat, your wrist strap should be snug and the bonding wire should be connected to the anti-static mat and to any bare metal on the computer being worked on. Once deployed properly, service parts can be removed from the ESD bag and placed directly on the anti-static mat. ESD-sensitive items are safe in your hand, on the anti-static mat, in the computer, or inside an ESD bag.
- **Wrist Strap and Bonding Wire** – The wrist strap and bonding wire can be either directly connected between your wrist and bare metal on the hardware if the anti-static mat is not required, or connect to the anti-static mat to protect hardware that is temporarily placed on the mat. The physical connection of the wrist strap and bonding wire between your skin, the anti-static mat, and the hardware is known as bonding. Use only Field Service kits with a wrist strap, anti-static mat, and bonding wire. Never use wireless wrist straps. Always be cautious that the internal wires of a wrist strap are prone to damage from normal wear and tear, and must be checked regularly with a wrist strap tester in order to avoid accidental ESD hardware damage. It is recommended to test the wrist strap and bonding wire at least once per week.
- **ESD Wrist Strap Tester** – The wires inside an ESD strap are prone to damage over time. When using an unmonitored kit, it is a best practice to regularly test the strap before each service, and at a minimum, test once per week. A wrist strap tester is the best method for doing this test. To perform the test, plug the bonding-wire of the wrist-strap into the tester while it is strapped to your wrist and push the button to test. A green LED is lit if the test is successful; a red LED is lit and an alarm sounds if the test fails.

 **NOTE:** It is recommended to always use the traditional wired ESD grounding wrist strap and protective anti-static mat when servicing Dell products. In addition, it is critical to keep sensitive parts separate from all insulator parts while servicing the computer.

Transporting sensitive components

When transporting ESD sensitive components such as replacement parts or parts to be returned to Dell, it is critical to place these parts in anti-static bags for safe transport.

Lifting equipment

Adhere to the following guidelines when lifting heavy equipment:

 **CAUTION: Do not lift greater than 50 pounds. Always obtain additional resources or use a mechanical lifting device.**

1. Get a firm balanced footing. Keep your feet apart for a stable base, and point your toes out.
2. Tighten stomach muscles. Abdominal muscles support your spine when you lift, offsetting the force of the load.
3. Lift with your legs, not your back.
4. Keep the load close. The closer it is to your spine, the less force it exerts on your back.
5. Keep your back upright, whether lifting or setting down the load. Do not add the weight of your body to the load. Avoid twisting your body and back.
6. Follow the same technique in reverse to set the load down.

After working inside your computer

About this task

 **CAUTION: Leaving stray or loose screws inside your computer may severely damage your computer.**

Steps

1. Replace all screws and ensure that no stray screws remain inside your computer.
2. Connect any external devices, peripherals, or cables you removed before working on your computer.
3. Replace any media cards, discs, or any other components that you removed before working on your computer.
4. Connect your computer and all attached devices to their electrical outlets.
5. Turn on your computer.

Technology and components

Topics:

- USB features
- HDMI 1.4- HDMI 2.0

USB features

Universal Serial Bus, or USB, was introduced in 1996. It dramatically simplified the connection between host system units and peripheral devices like mice, keyboards, external drives, and printers.

Table 1. USB evolution

Type	Data Transfer Rate	Category
USB 2.0	480 Mbps	High Speed
USB 3.2 Gen 1	5 Gbps	SuperSpeed USB 5 Gbps
USB 3.2 Gen 2	10 Gbps	SuperSpeed USB 10 Gbps

USB 3.2

For years, the USB 2.0 has been firmly entrenched as the de facto interface standard in the personal computer world with about 6 billion devices sold, and yet the need for more speed grows by ever faster computing hardware and ever greater bandwidth demands. The USB 3.0/USB 3.1 Gen 1 finally has the answer to the consumers' demands with a theoretically 10 times faster than its predecessor. In a nutshell, USB 3.2 features are as follows:

- Higher transfer rates (up to 20 Gbps).
- Increased multilane operation of 10 Gbps each.
- Increased maximum bus power and increased device current draw to better accommodate power-hungry devices.
- New power management features.
- Full-duplex data transfers and support for new transfer types.
- Backward compatibility with USB 3.1/3.0 and USB 2.0.
- New connectors and cable.

Speed

- The USB 3.2 provides three transfer rates:
 - USB 3.2 Gen 1 (5 Gbps)
 - USB 3.2 Gen 2 (10 Gbps)
 - USB 3.2 Gen 2x2 (20 Gbps)
- The marketing names below indicates the performance signaling that a product delivers in the product packaging, and any other marketing materials:
 - SuperSpeed USB 5Gbps—product signals at 5 Gbps
 - SuperSpeed USB 10Gbps—product signals at 10 Gbps
 - SuperSpeed USB 20Gbps—product signals at 20 Gbps

i NOTE:

- USB 3.2 protocol specification defines only the performance capabilities that may be implemented in a product.
- USB 3.2 is not USB Power Delivery or USB Battery Charging.

HDMI 1.4- HDMI 2.0

This topic explains the HDMI 1.4/2.0 and its features along with the advantages.

HDMI (High-Definition Multimedia Interface) is an industry-supported, uncompressed, all-digital audio/video interface. HDMI provides an interface between any compatible digital audio/video source, such as a DVD player, or A/V receiver and a compatible digital audio and/or video monitor, such as a digital TV (DTV). The intended applications for HDMI TVs, and DVD players. The primary advantage is cable reduction and content protection provisions. HDMI supports standard, enhanced, or high-definition video, plus multichannel digital audio on a single cable.

 **NOTE:** The HDMI 1.4 will provide 5.1 channel audio support.

HDMI 1.4- HDMI 2.0 Features

- **HDMI Ethernet Channel** - Adds high-speed networking to an HDMI link, allowing users to take full advantage of their IP-enabled devices without a separate Ethernet cable
- **Audio Return Channel** - Allows an HDMI-connected TV with a built-in tuner to send audio data "upstream" to a surround audio system, eliminating the need for a separate audio cable
- **3D** - Defines input/output protocols for major 3D video formats, paving the way for true 3D gaming and 3D home theater applications
- **Content Type** - Real-time signaling of content types between display and source devices, enabling a TV to optimize picture settings based on content type
- **Additional Color Spaces** - Adds support for additional color models used in digital photography and computer graphics
- **4K Support** - Enables video resolutions far beyond 1080p, supporting next-generation displays that will rival the Digital Cinema systems used in many commercial movie theaters
- **HDMI Micro Connector** - A new, smaller connector for phones and other portable devices, supporting video resolutions up to 1080p
- **Automotive Connection System** - New cables and connectors for automotive video systems, designed to meet the unique demands of the motoring environment while delivering true HD quality

Advantages of HDMI

- Quality HDMI transfers uncompressed digital audio and video for the highest, crispest image quality.
- Low-cost HDMI provides the quality and functionality of a digital interface while also supporting uncompressed video formats in a simple, cost-effective manner
- Audio HDMI supports multiple audio formats from standard stereo to multichannel surround sound
- HDMI combines video and multichannel audio into a single cable, eliminating the cost, complexity, and confusion of multiple cables currently used in A/V systems
- HDMI supports communication between the video source (such as a DVD player) and the DTV, enabling new functionality

Disassembly and reassembly

i **NOTE:** The images in this document may differ from your computer depending on the configuration you ordered.

Topics:

- Cover
- Front Bezel
- Hard drive
- Fan assembly
- Optical drive
- M.2 SSD card
- Power supply unit
- Speaker
- Heat sink assembly
- Memory modules
- Expansion card
- WLAN module
- Coin-cell battery
- Processor
- System board

Cover

Removing the side cover

Prerequisites

1. Follow the procedure in [Before working inside your computer](#).

i **NOTE:** Ensure that you remove the security cable from the security-cable slot (if applicable).

About this task

The following images indicate the location of the side cover and provide a visual representation of the removal procedure.



Steps

To remove the cover:

- a. Loosen the two (#6-32) captive screws that secure the cover to the computer.
- b. Slide the cover towards the back of your computer.

Installing the cover

About this task

The following image indicates the location of the side cover and provides a visual representation of the installation procedure.



Steps

1. Align the side cover with the guide lines on the chassis.
2. Slide the side cover towards the back of the system to install.

3. Replace the thumbscrew (6x32) to secure the side cover to the system.
4. Follow the procedure in [After working inside your computer](#).

Front Bezel

Removing the front bezel

Prerequisites

1. Follow the procedure in [Before working inside your computer](#).
2. Remove the [side cover](#).

About this task

The following images indicate the location of the side cover and provide a visual representation of the removal procedure.

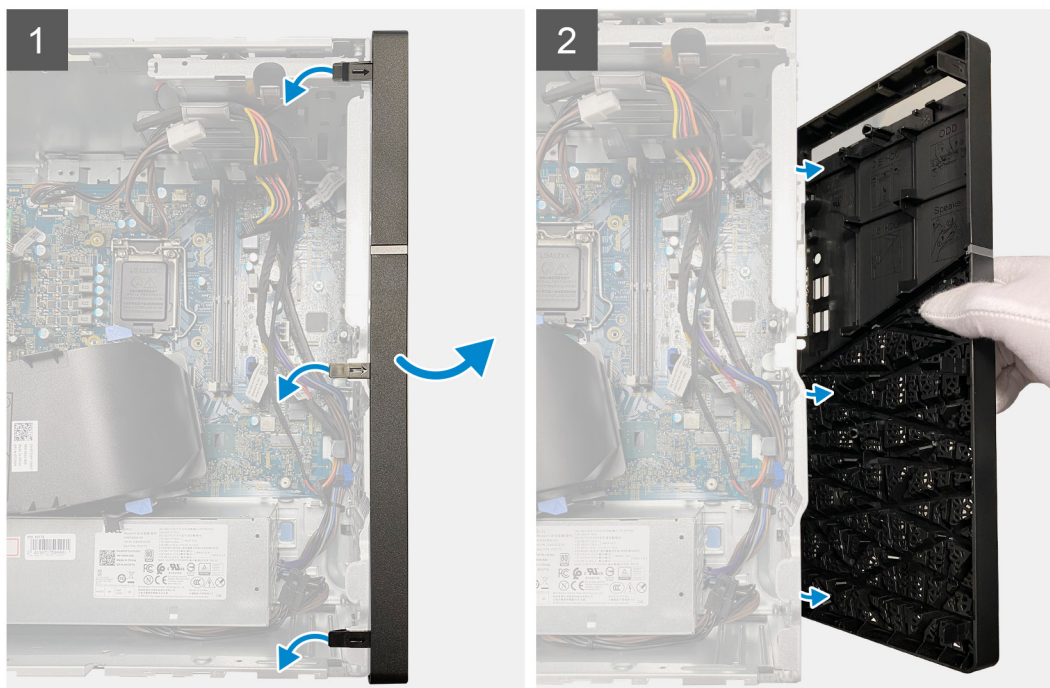

Steps

1. To remove the front bezel:
2. Pry the retention tabs to release the front bezel from the system [1] and remove the front bezel from the system [2].
3. Remove the front bezel from the computer.

Installing the front bezel

Prerequisites

If you are replacing a component, remove the existing component before performing the installation procedure.

About this task

The following image indicates the location of the front bezel and provides a visual representation of the installation procedure.

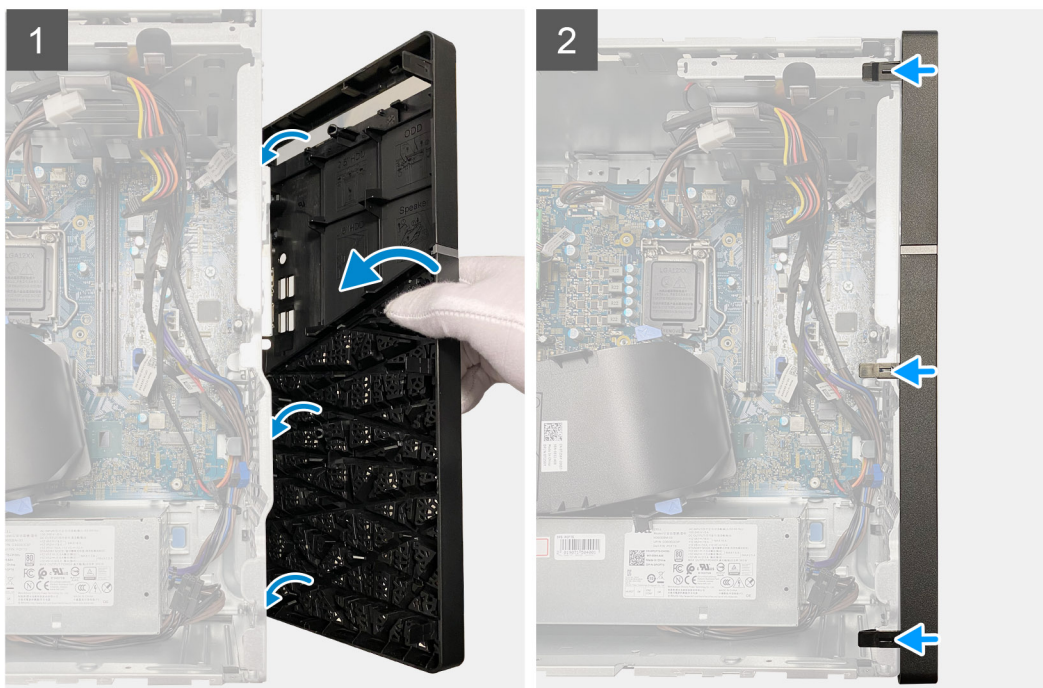

Steps

1. Position the bezel to align the tabs with the slots on the chassis.
2. Press the bezel until the release tabs click into place.

Next steps

1. Install the [side cover](#)
2. Follow the procedure in [After working inside your computer](#).

Hard drive

2.5 inch hard drive

Removing the 2.5 inch hard drive

Prerequisites

1. Follow the procedure in [Before working inside your computer](#).
2. Remove the [side cover](#)

About this task

The following images indicate the location of the side cover and provide a visual representation of the removal procedure.

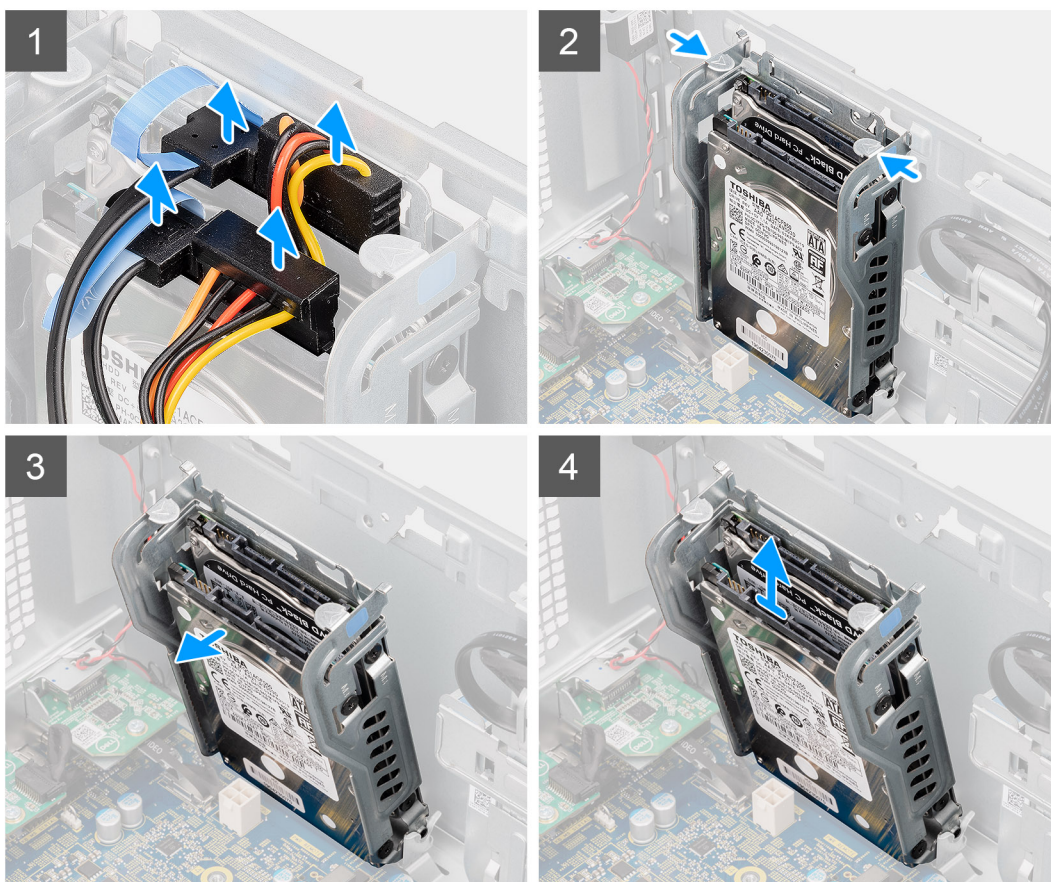
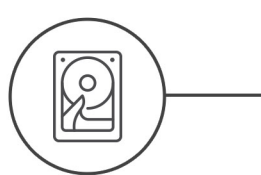

Steps

1. To remove the 2.5 inch hard drive:
2. Disconnect the hard drive data cable and power cable from the hard drive [1].

3. Press the release tabs on the hard-drive assembly and slide it towards the front of the system to disconnect it from the connector on the system board [2]
4. Slide [3] and lift the hard drive away from the computer [4].

Removing the hard-drive bracket

Prerequisites

1. Follow the procedure in [Before working inside your computer](#).
2. Remove the [side cover](#).
3. Remove the [front bezel](#).
4. Remove the [2.5 in. hard-drive assembly](#).

About this task

The following images indicate the location of the hard-drive bracket and provide a visual representation of the removal procedure.



4x
M3x3.5

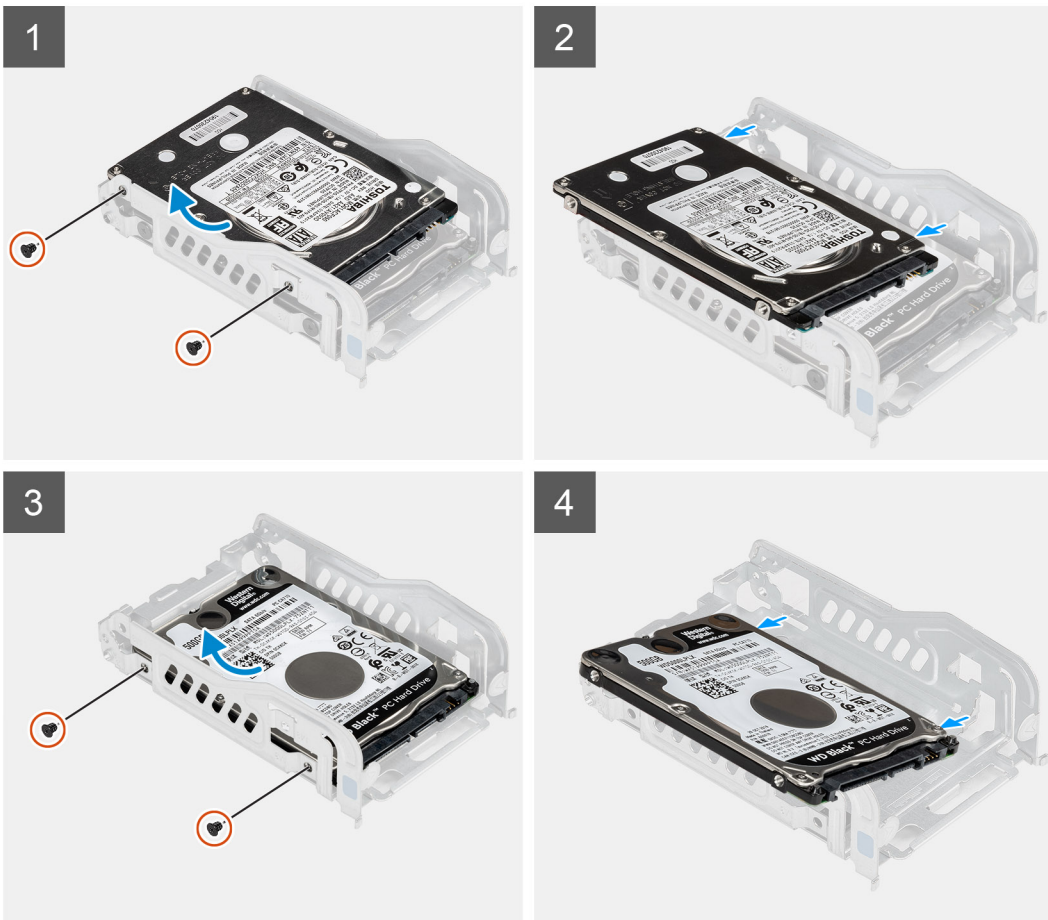

Steps

1. Loosen the two M3 x 3.5 screws from the first 2.5 inch hard-drive [1].
2. Lift the hard-drive out of the bracket [2].

3. Loosen the two M3 x 3.5 screws from the second 2.5 inch hard-drive [3].
4. Lift the hard-drive out of the bracket [4].

Installing the hard-drive bracket

About this task



4x
M3x3.5

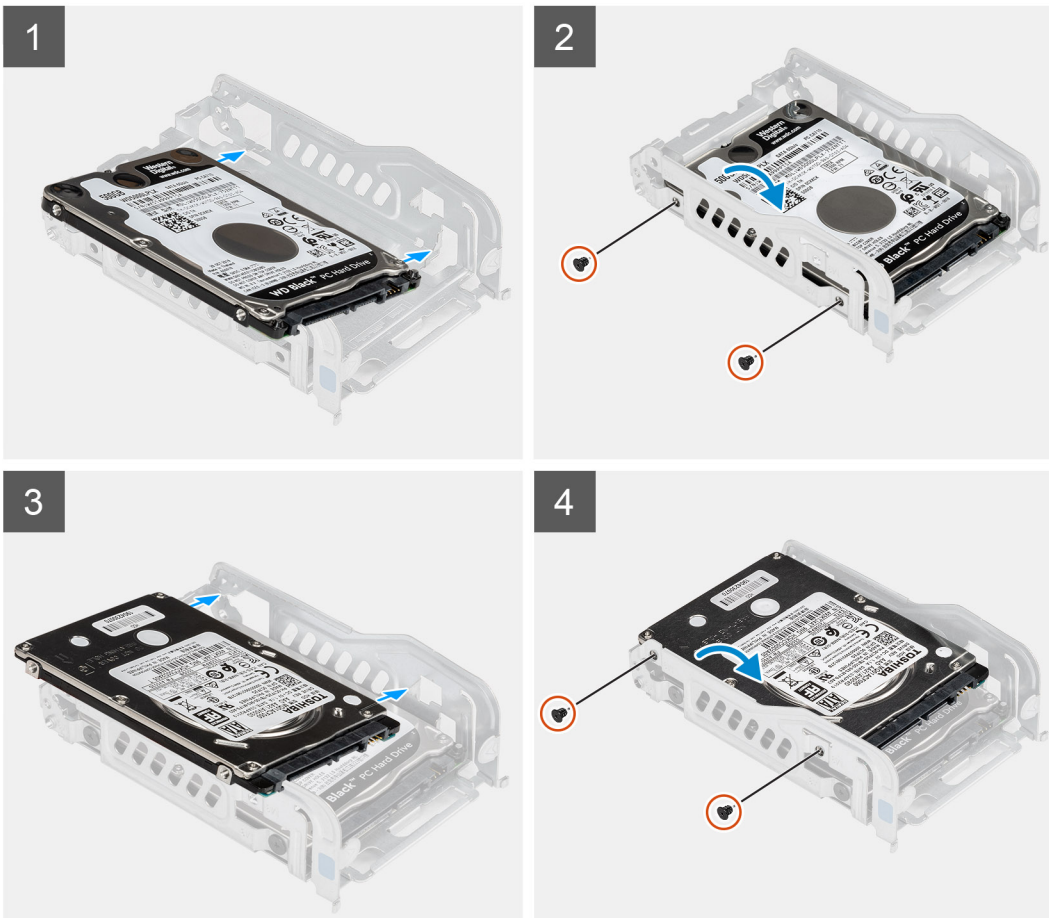

Steps

1. Place the second 2.5 inch hard-drive into the bracket [1].
2. Align and tighten the two M3 x 3.5 screws insert the pins on the drive bracket with the slots on the drive [2].

i **NOTE:** Note the orientation of the hard-drive so that you can replace it correctly.

3. Place the first 2.5 inch hard-drive into the bracket [3].
4. Align and tighten the two M3 x 3.5 screws insert the pins on the drive bracket with the slots on the drive [4].

Next steps

Next steps

1. Install the [2.5 in. hard-drive assembly](#).

2. Install the [side cover](#).
3. Install the [front bezel](#)
4. Follow the procedure in [After working inside your computer](#).

Installing the 2.5 inch hard drive

About this task

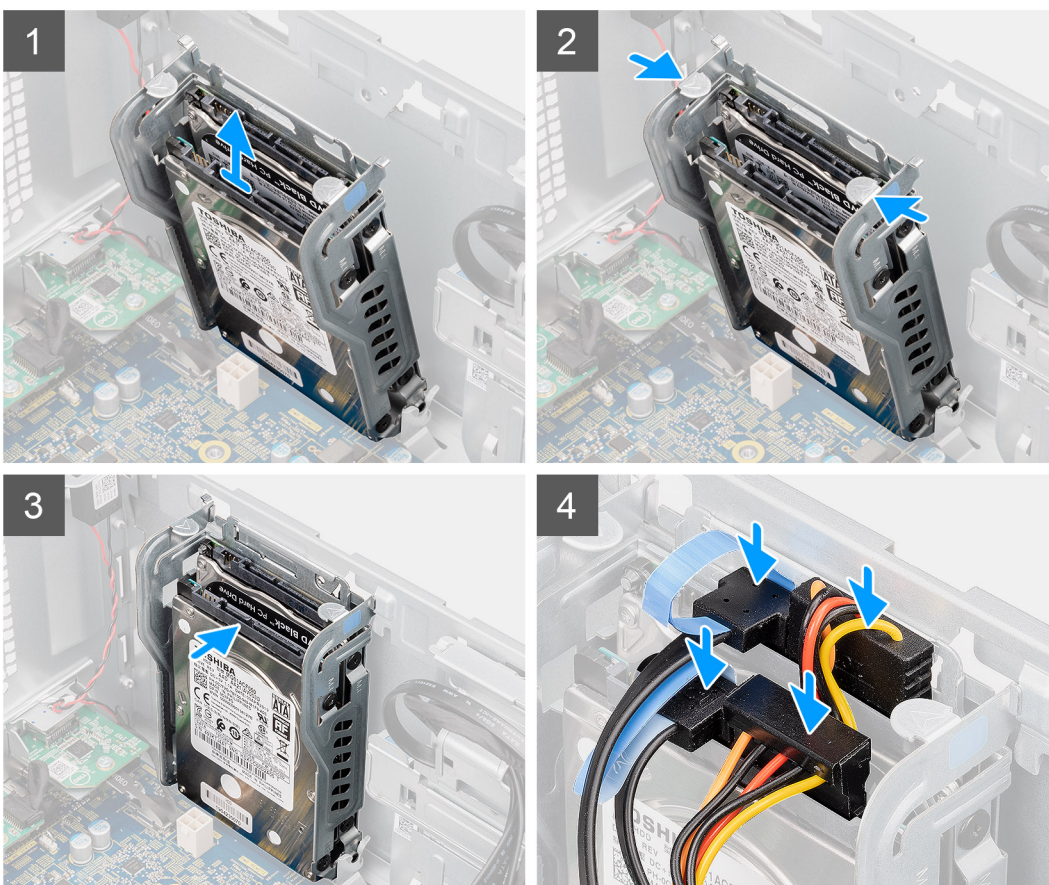
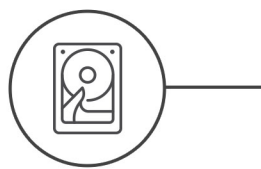

Steps

1. Insert the 2.5 inch hard drive into the slot on the computer [1].
2. Tighten the two screws (M3L3.5) to secure the hard drive to the computer [2].
3. Slide [3] and connect the hard drive data cable and power cable to the hard drive [4].

Next steps

1. Install the [side cover](#).
2. Install the [front bezel](#)
3. Follow the procedure in [After working inside your computer](#).

3.5 inch hard drive

Removing the 3.5 inch hard drive

Prerequisites

1. Follow the procedure in [Before working inside your computer](#).
2. Remove the [side cover](#).
3. Remove the [front bezel](#).

About this task



2x
6-32

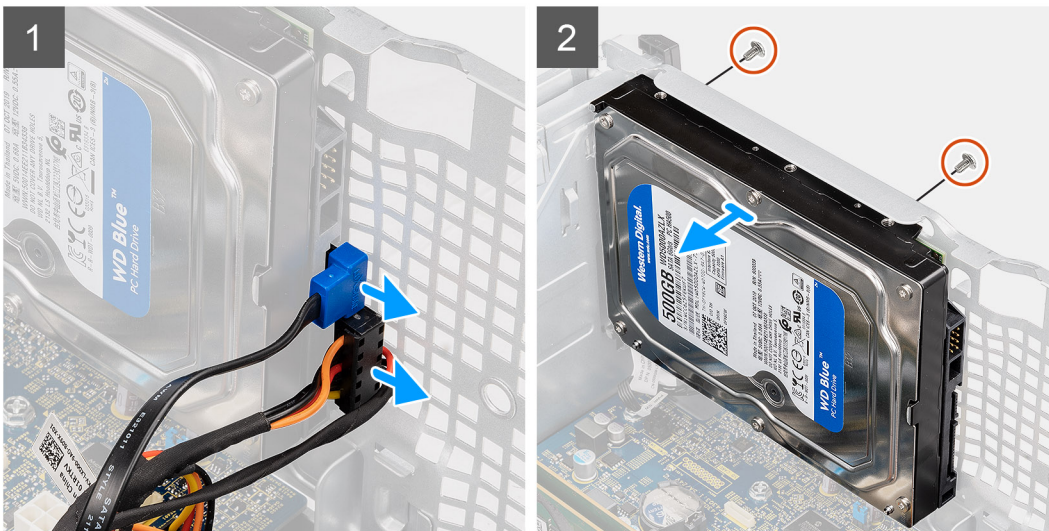
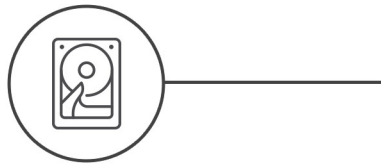

Steps

To remove the 3.5 inch hard drive:

- a. Disconnect the hard drive data cable and power cable from the hard drive.
- b. Remove the two screws (6-32xL3.6) that secure the hard drive to the computer.
- c. Slide and lift the hard drive away from the computer.

Installing the 3.5 inch hard drive

About this task



2x
6-32

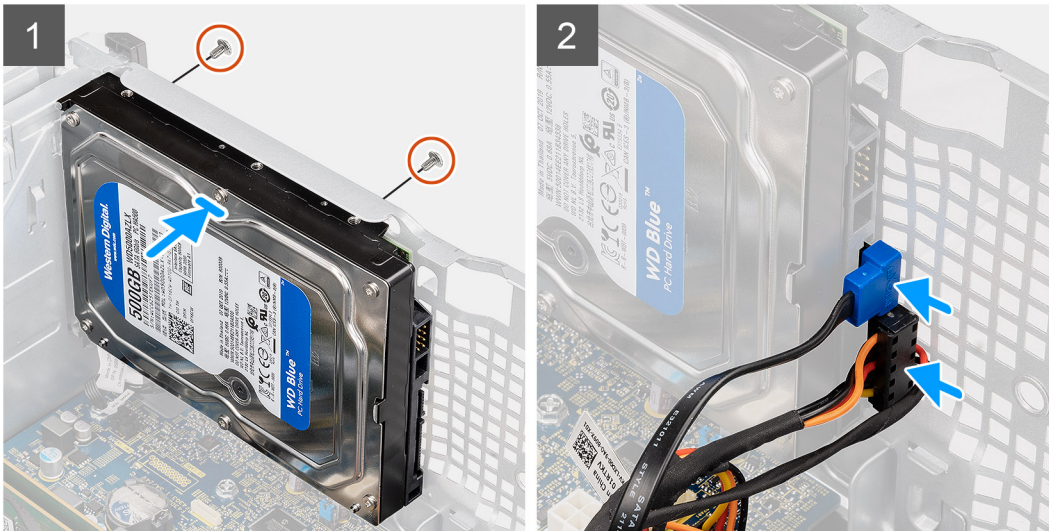
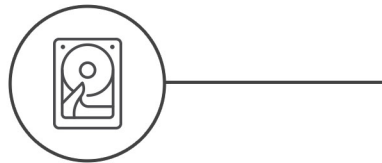

Steps

1. Insert the 3.5 inch hard drive into the slot on the computer.
2. Tighten the two screws(6-32xL3.6) to secure the hard drive to the computer.
3. Connect the hard drive data cable and power cable to the hard drive.

Next steps

Next steps

1. Install the [front bezel](#).
2. Install the [side cover](#).
3. Follow the procedure in [After working inside your computer](#).

Fan assembly

Removing the fan assembly

Prerequisites

1. Follow the procedure in [Before working inside your computer](#).
2. Remove the [side cover](#).
3. Remove the [front bezel](#).
4. Remove the [2.5 in. hard-drive assembly](#).

About this task

The following images indicate the location of the fan assembly and provide a visual representation of the removal procedure.

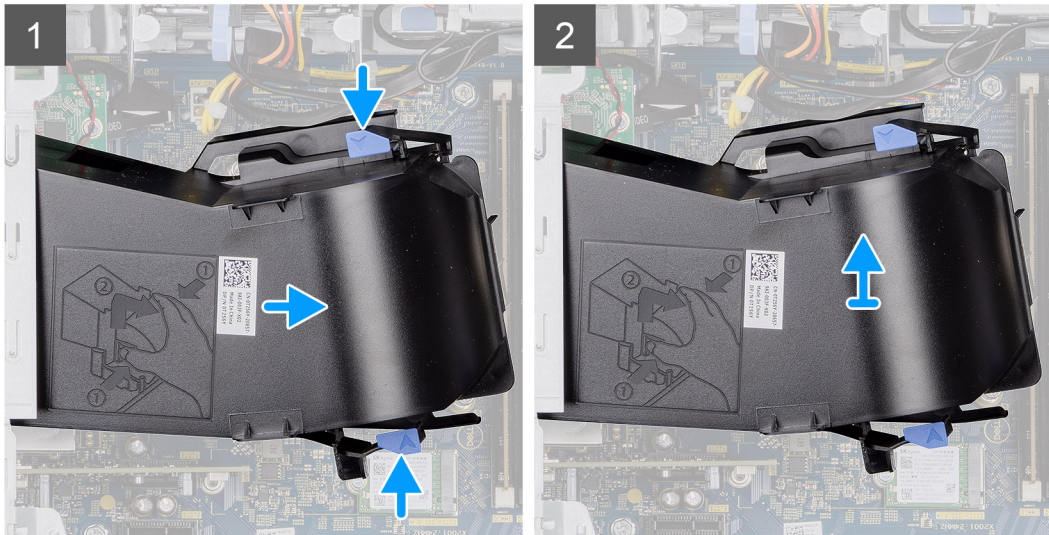

Steps

1. Press the blue tabs on both sides of the fan, and slide to lift the fan to release it from the system.
2. Turn the fan assembly over.
3. Disconnect the fan cable from the connector on the system board. Lift the fan assembly out of the system.

Installing the fan assembly

About this task

The following images indicate the location of the fan assembly and provide a visual representation of the removal procedure.

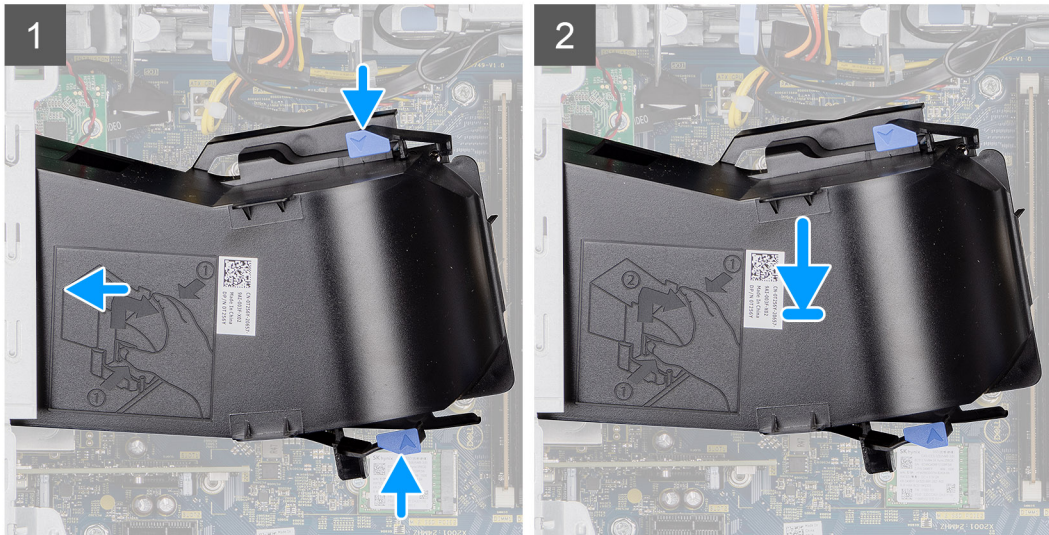

Steps

1. Connect the fan cable to the connector on the system board.
2. Turn the fan assembly over.
3. Press the release tab on the fan assembly and place it on the system until it clicks into place.

Next steps

Next steps

1. Install the [2.5 in. hard-drive assembly](#).
2. Install the [front bezel](#).
3. Install the [side cover](#).
4. Follow the procedure in [After working inside your computer](#).

Optical drive

Removing the optical drive

Prerequisites

1. Follow the procedure in [Before working inside your computer](#).
2. Remove the [side cover](#).
3. Remove the [front bezel](#).

About this task

The following images indicate the location of the hard-drive bracket and provide a visual representation of the removal procedure.

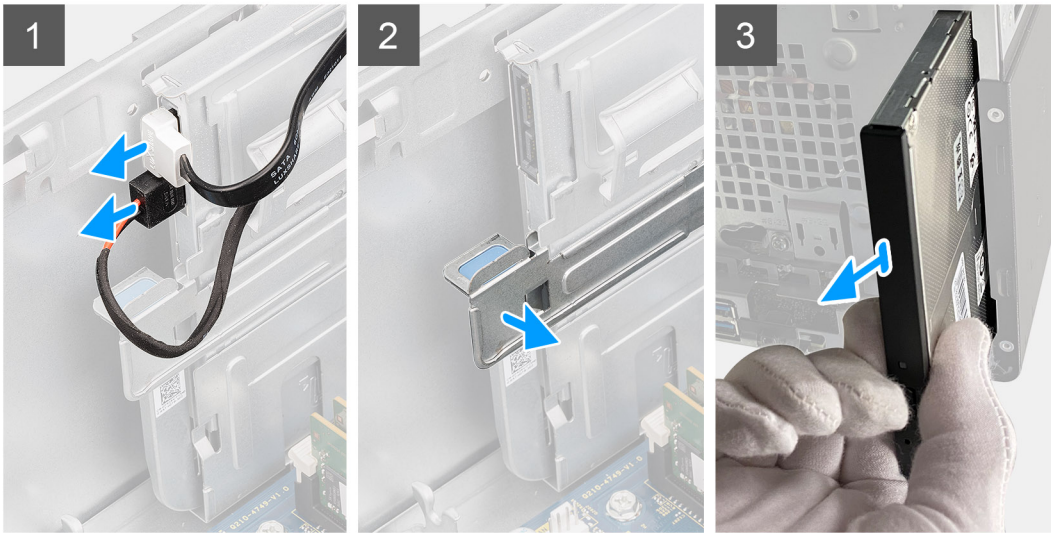

Steps

1. To remove the optical drive:
2. Disconnect the optical drive data and the power cable from the optical drive [1].
3. Remove the bracket that secure the optical drive to the computer [2].
4. Pull the optical drive out of the computer [3].

Installing the optical drive

About this task



Steps

1. Insert the optical drive into the slot on the computer.
2. Replace the metal bracket to secure the optical drive to the computer.
3. Connect the optical drive data cable and power cable to the optical drive.

Next steps

Next steps

1. Install the [front bezel](#).
2. Install the [side cover](#).
3. Follow the procedure in [After working inside your computer](#).

M.2 SSD card

Removing the M.2 SSD card

Prerequisites

1. Follow the procedure in [Before working inside your computer](#).
2. Remove the [side cover](#).
3. Remove the [front bezel](#).

About this task



1x
M2x3

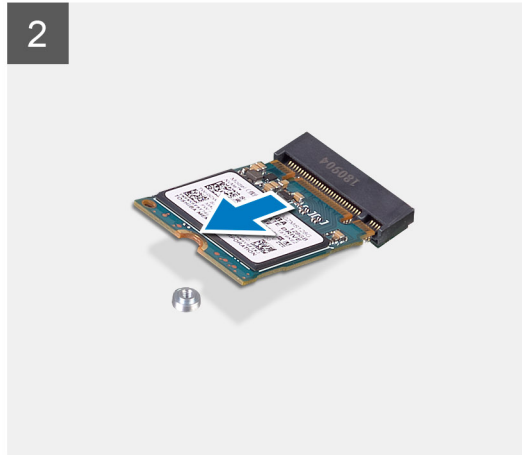
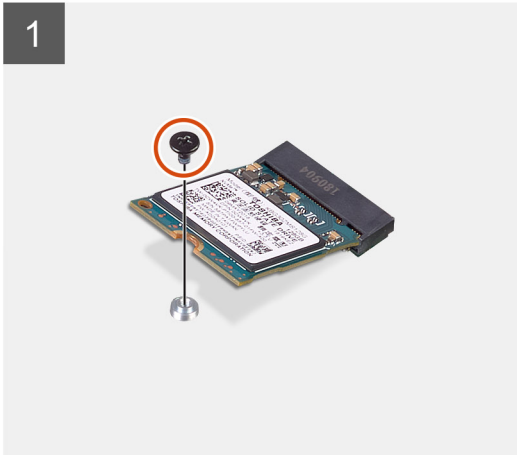
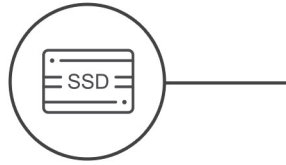

Steps

1. To remove the M.2 PCIe SSD:
2. Remove the screw (M2 x 3.5) that secures the M.2 SSD card to the system board [1].
3. Slide and lift the SSD from the system [2].

Installing the M.2 SSD card

About this task



1x
M2x3

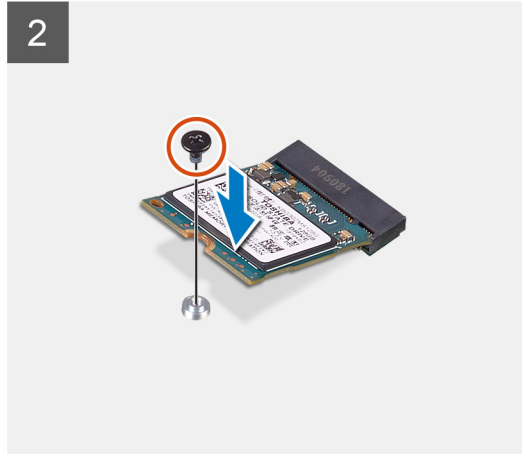
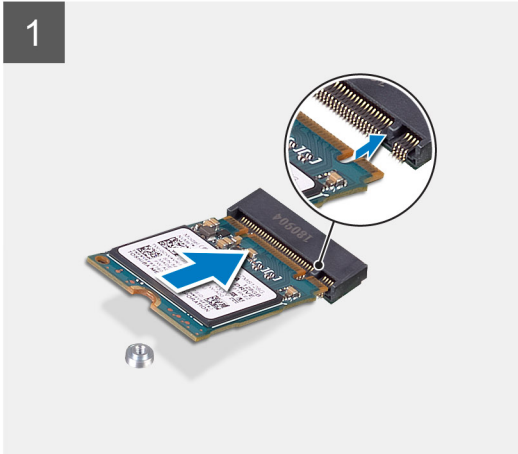
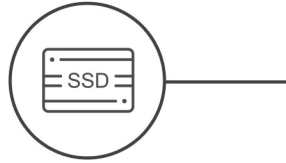

Steps

1. Slide the M.2 2230 SSD card into the connector on the system board.
2. Replace the screw (M2 x 3.5) to secure the M.2 SSD card to the system board.

Next steps

Next steps

1. Install the [front bezel](#).
2. Install the [side cover](#).
3. Follow the procedure in [After working inside your computer](#).

Power supply unit

Removing the power supply unit

Prerequisites

1. Follow the procedure in [Before working inside your computer](#).
2. Remove the [side cover](#).
3. Remove the [front bezel](#)
4. Remove the [fan assembly](#).

About this task

The following images indicate the location of the hard-drive bracket and provide a visual representation of the removal procedure.



3x
6-32

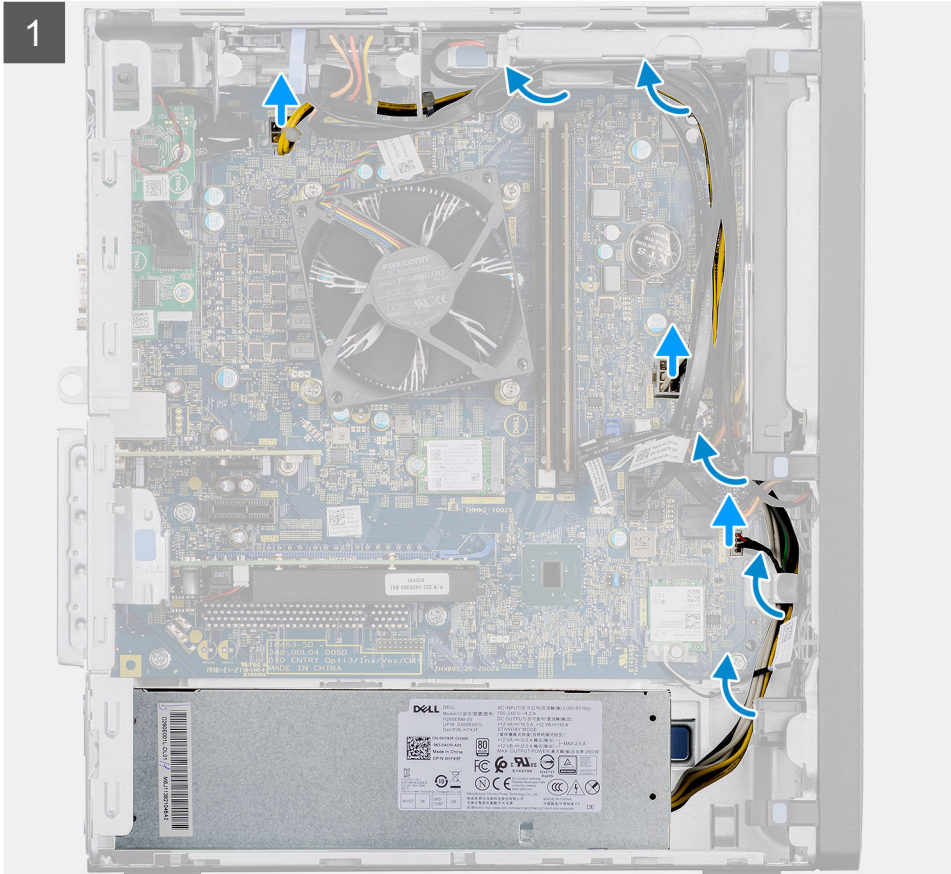

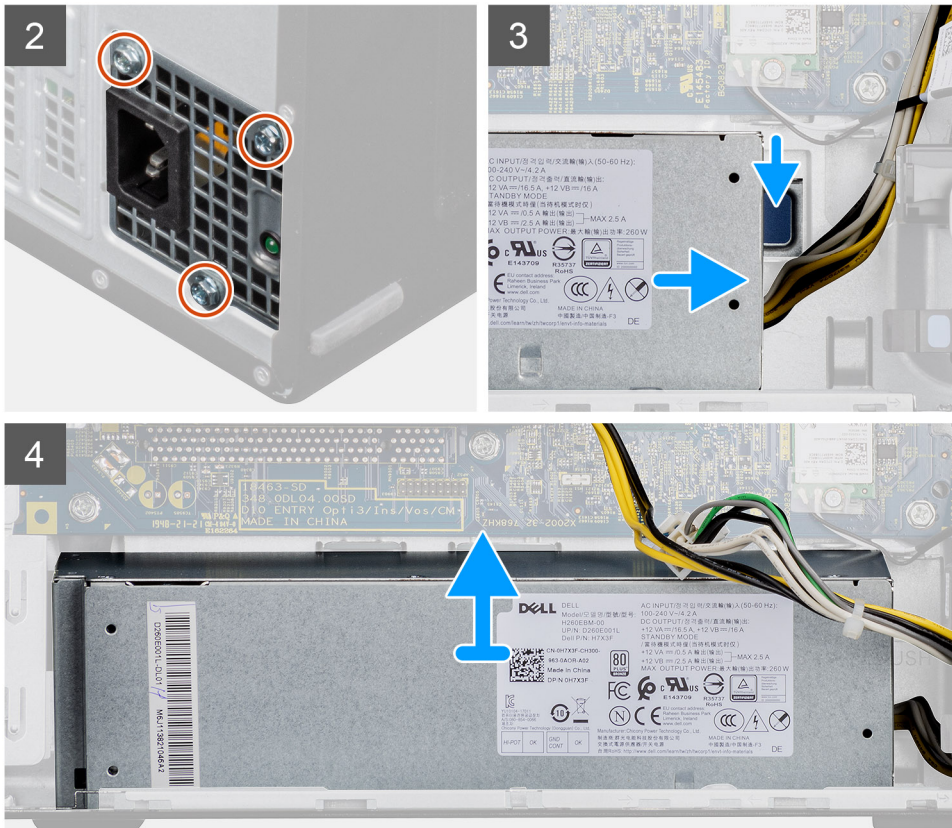

Steps

1. To disconnect the cables:
2. Disconnect the power cables from the system board and unroute them from the routing guides on the chassis
3. Remove the three (#6-32) screws that secure the power-supply unit to the chassis.
4. Press the securing clip and slide the power-supply unit away from the back of the chassis.
5. Lay the computer on the right side
6. Lift the power-supply unit off the chassis

Installing the power supply unit

About this task



3x
6-32

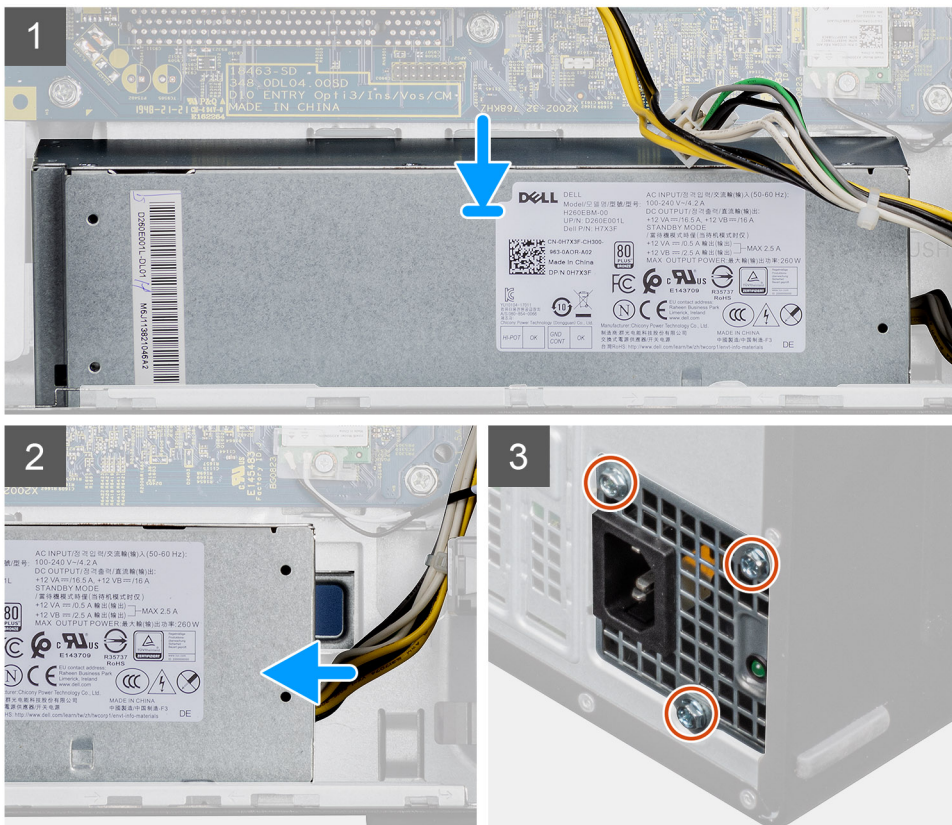



Steps

1. Slide the power-supply unit into the chassis until the securing tab snaps into position.
2. Replace the three screws (#6-32) that secure the power-supply unit to the chassis..
3. Route the power cable through the routing guides on the chassis and connect the power cables to their respective connectors on the system board.
4. Connect the 4-pin power cable to the system board.

Next steps

Next steps

1. Install the [fan assembly](#).
2. Install the [front bezel](#).
3. Install the [side cover](#).
4. Follow the procedure in [After working inside your computer](#).

Speaker

Removing the speaker

Prerequisites

1. Follow the procedure in [Before working inside your computer](#).
2. Remove the [side cover](#).
3. Remove the [front bezel](#).

About this task

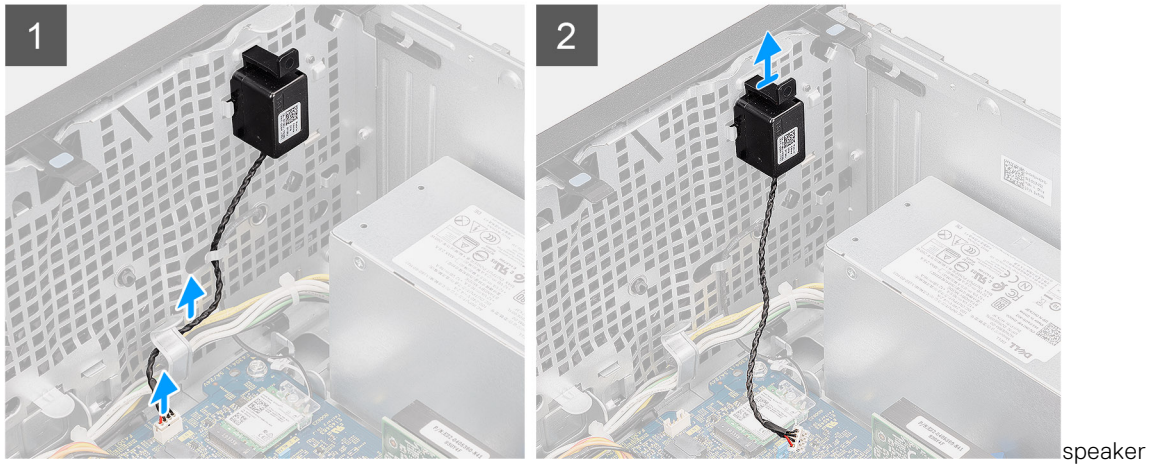

Steps

1. To remove the speaker:
2. Disconnect the speaker cable from system board [1].
3. Press the securing tab on the speaker and remove the speaker from the chassis [2].

Installing the speaker

About this task

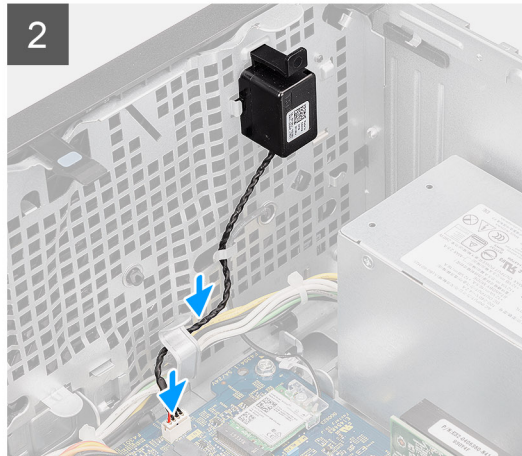
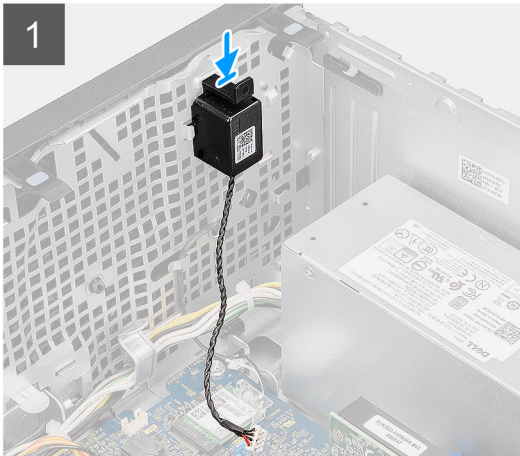
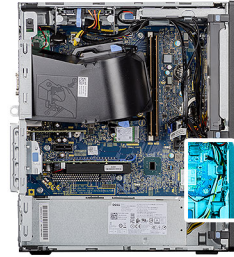

Steps

1. Slide the speaker module into the slot.
2. Connect the speaker cable to the system board.

Next steps

Next steps

1. Install the [front bezel](#).
2. Install the [side cover](#).
3. Follow the procedure in [After working inside your computer](#).

Heat sink assembly

Removing the heat sink assembly

Prerequisites

1. Follow the procedure in [Before working inside your computer](#).
2. Remove the [side cover](#).
3. Remove the [front bezel](#).

About this task

The following images indicate the location of the heatsink assembly and provide a visual representation of the removal procedure.

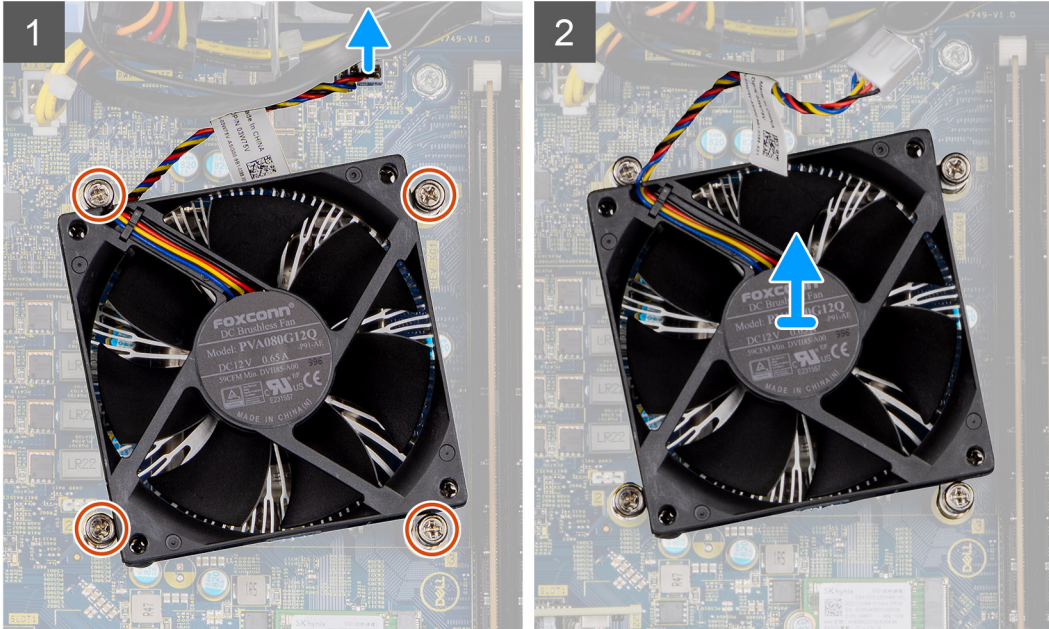
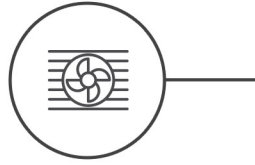

Steps

1. To remove the heat sink assembly:
2. Disconnect the cable from the connector on the system board.
3. Loosen the captive screws in a sequential order [4,3,2,1].

i **NOTE:** Remove the screws that secure the heat sink to the system board in the order of the callouts shown .

4. Lift the heat sink assembly away from the computer .

Installing the heat sink assembly

About this task

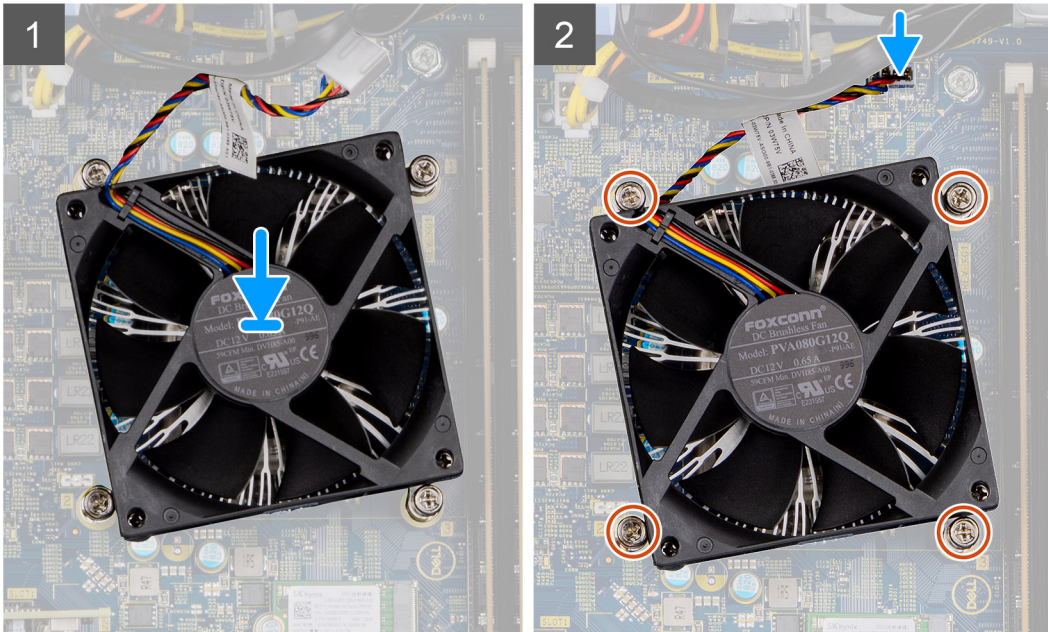
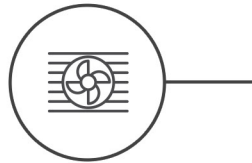

Steps

1. Align the heat sink assembly with screw holders and place the heat sink assembly on the system board.
2. Tighten the captive screws in a to secure the heat sink assembly to the system board .

i **NOTE:** Tighten the screws on the system board in the order of the callout numbers [1, 2, 3, 4].

3. Connect the cable to the connector on the system board.

Next steps

Next steps

1. Install the [front bezel](#).
2. Install the [side cover](#).
3. Follow the procedure in [After working inside your computer](#).

Memory modules

Removing the memory module

Prerequisites

1. Follow the procedure in [Before working inside your computer](#).

2. Remove the [side cover](#).

About this task

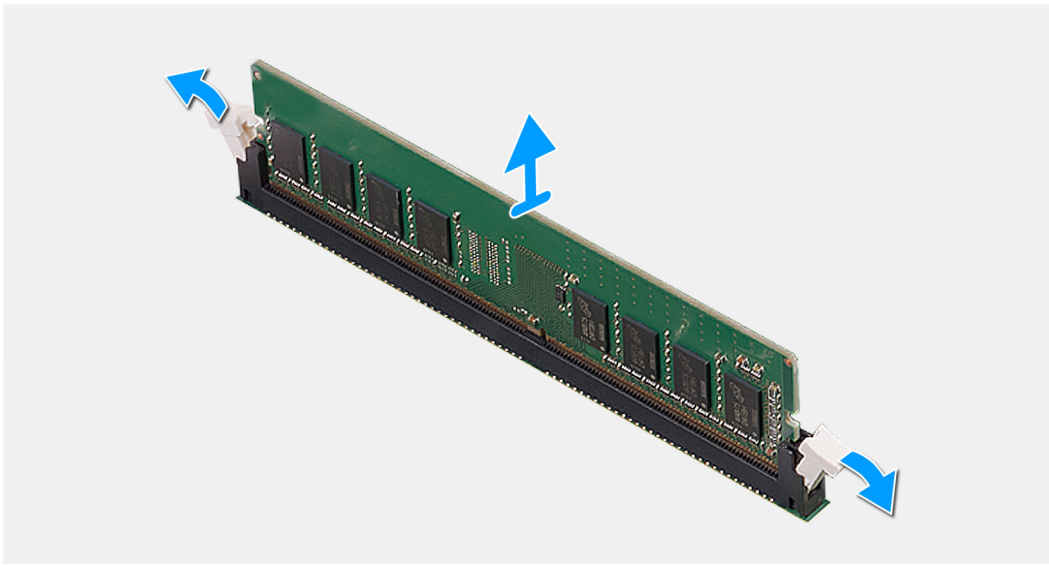
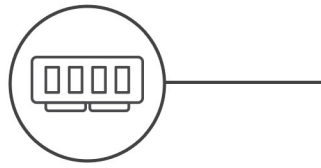

Steps

1. To remove the memory module:
2. Pull the securing clips from both side of the memory module until the memory module pops up.
3. Slide and remove the memory module from the memory-module slot

Installing the memory module

About this task

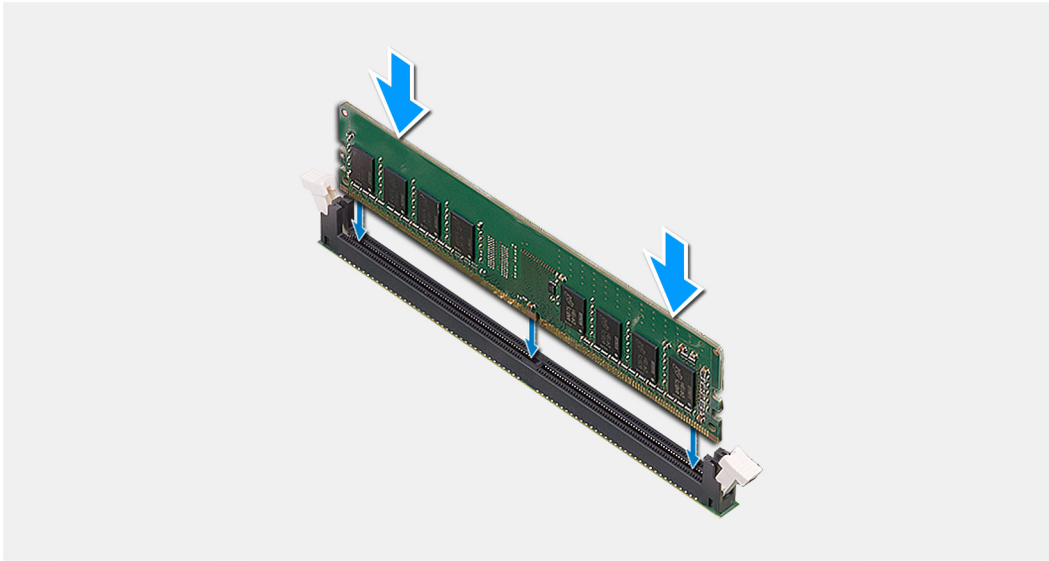
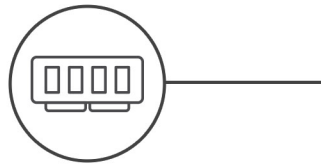

Steps

Align the memory module with the connector on the system board [1] and insert the memory module into the memory module socket until the clips secure the memory module.

Next steps

Next steps

1. Install the [side cover](#).
2. Follow the procedure in [After working inside your computer](#).

Expansion card

Removing the expansion card

Prerequisites

1. Follow the procedure in [Before working inside your computer](#).
2. Remove the [side cover](#).

About this task

The following images indicate the location of the expansion card and provide a visual representation of the removal procedure.

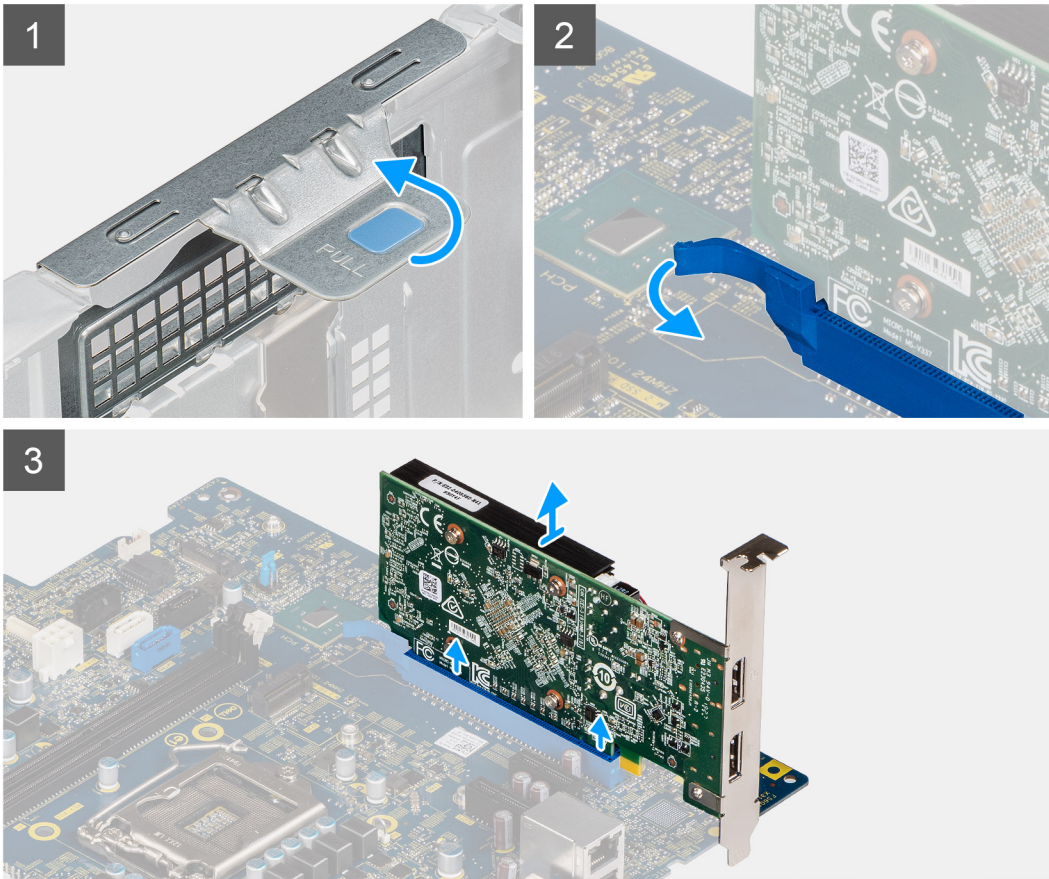

Steps

1. To remove the expansion card:
2. Pull the metal card-retention latch from the computer [1].
3. Push the release tab [2] and lift the expansion card from the system board [3] .

Installing the expansion card

About this task

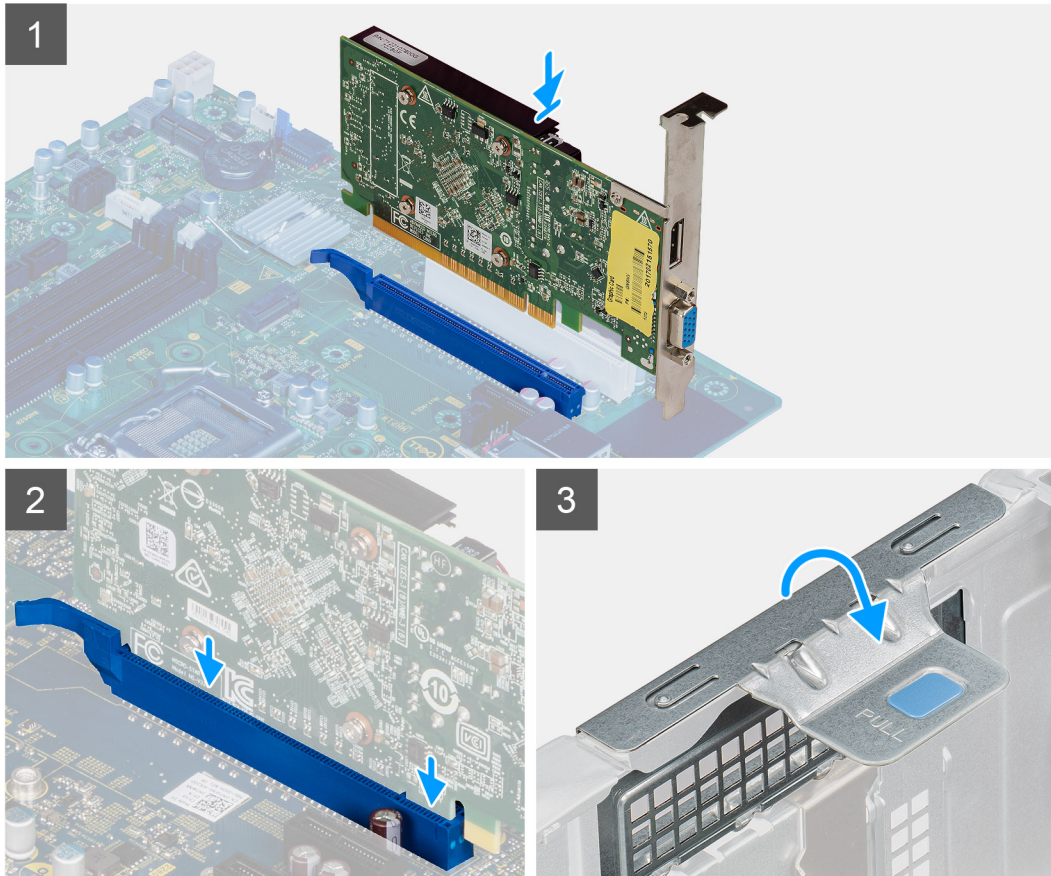

Steps

1. Insert the expansion card in the connector on the system board and press down until it is secured [1].
2. Push the PCI bracket back to its position [2].
3. Pull and close PCI bracket metal card-retention latch to the computer [3].

Next steps

Next steps

1. Install the [side cover](#).
2. Follow the procedure in [After working inside your computer](#).

WLAN module

Removing the WLAN module

Prerequisites

1. Follow the procedure in [Before working inside your computer](#).
2. Remove the [side cover](#).

About this task

The following images indicate the location of the WLAN module and provide a visual representation of the removal procedure.



1x
M2x3

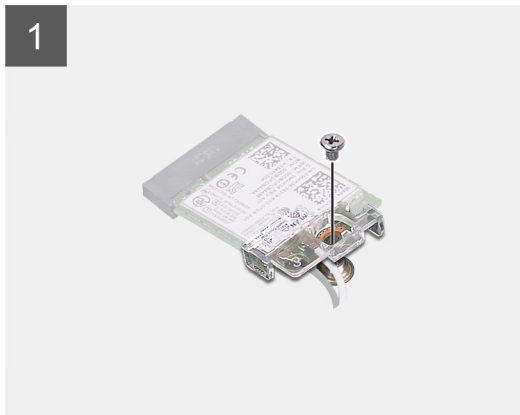
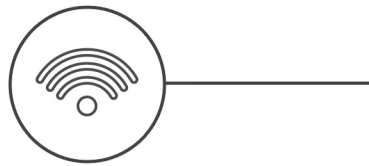

Steps

1. To remove the WLAN module
2. Remove the (M2x3) screw that secures the WLAN card to the system board
3. Lift the WLAN card bracket away from the WLAN card
4. Disconnect the antenna cables from the WLAN card.
5. Slide and remove the WLAN card from the connector on the system board

Installing the WLAN module

About this task



1x
M2x3

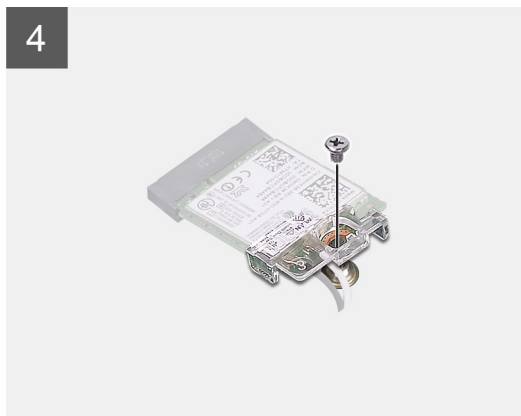
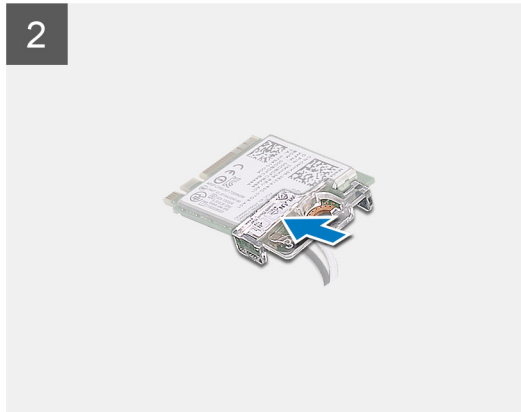
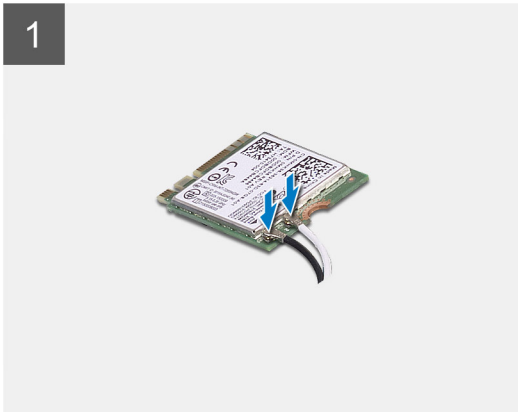
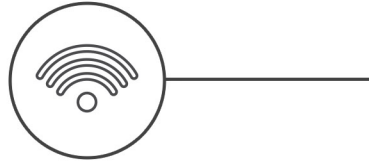

Steps

1. Connect the antenna cables to the WLAN card [1]
2. Place the WLAN card bracket to secure the antenna cables [2]
3. Align the notch on the WLAN card with the tab on the WLAN card slot. Insert the WLAN card into the connector on the system board [3]
4. Replace the (M2x3) screw to secure the WLAN card bracket to the WLAN card [4]

Next steps

Next steps

1. Install the [side cover](#).
2. Follow the procedure in [After working inside your computer](#).

Coin-cell battery

Removing the coin cell battery

Prerequisites

1. Follow the procedure in [Before working inside your computer](#).
2. Remove the [side cover](#).

About this task

The following images indicate the location of the coin cell battery and provide a visual representation of the removal procedure.

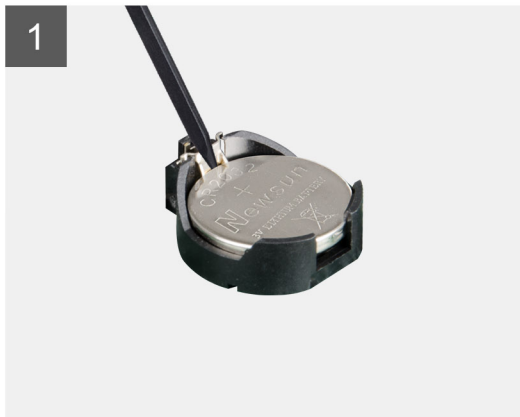
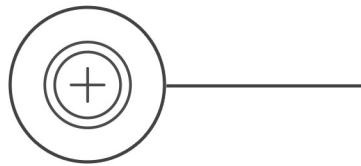

Steps

1. To remove the coin cell battery:
2. Using a plastic scribe, gently pry the coin-cell battery out of the battery socket on the system board
3. Remove the coin-cell battery out of the system

Installing the coin cell battery

About this task

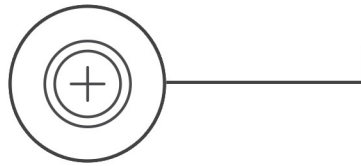

Steps

1. Insert the coin cell battery with the "+" sign facing up and slide it under the securing tabs at the positive side of the connector .
2. Press the battery into the connector until it locks into place.

Next steps

Next steps

1. Install the [side cover](#).
2. Follow the procedure in [After working inside your computer](#).

Processor

Removing the processor

Prerequisites

1. Follow the procedure in [Before working inside your computer](#).
2. Remove the [side cover](#).
3. Remove the [front bezel](#).

About this task

The following images indicate the location of the processor and provide a visual representation of the removal procedure.

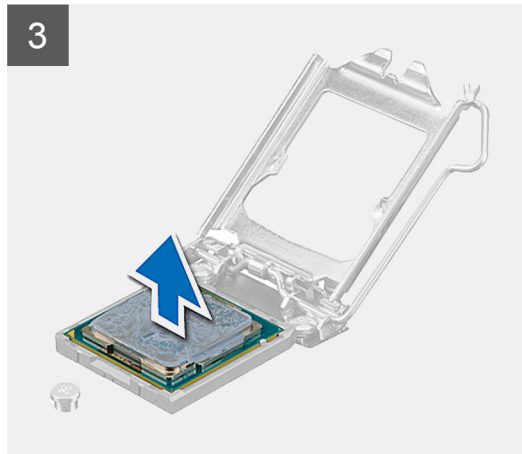
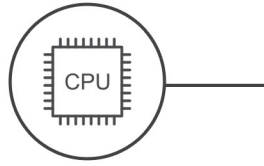

Steps

1. To remove the processor:
2. Press the release lever down and then move it outward to release it from the retention hook [1].
3. Lift the processor cover and remove the processor from the socket. Place it in an antistatic bag [3].

Installing the processor

About this task

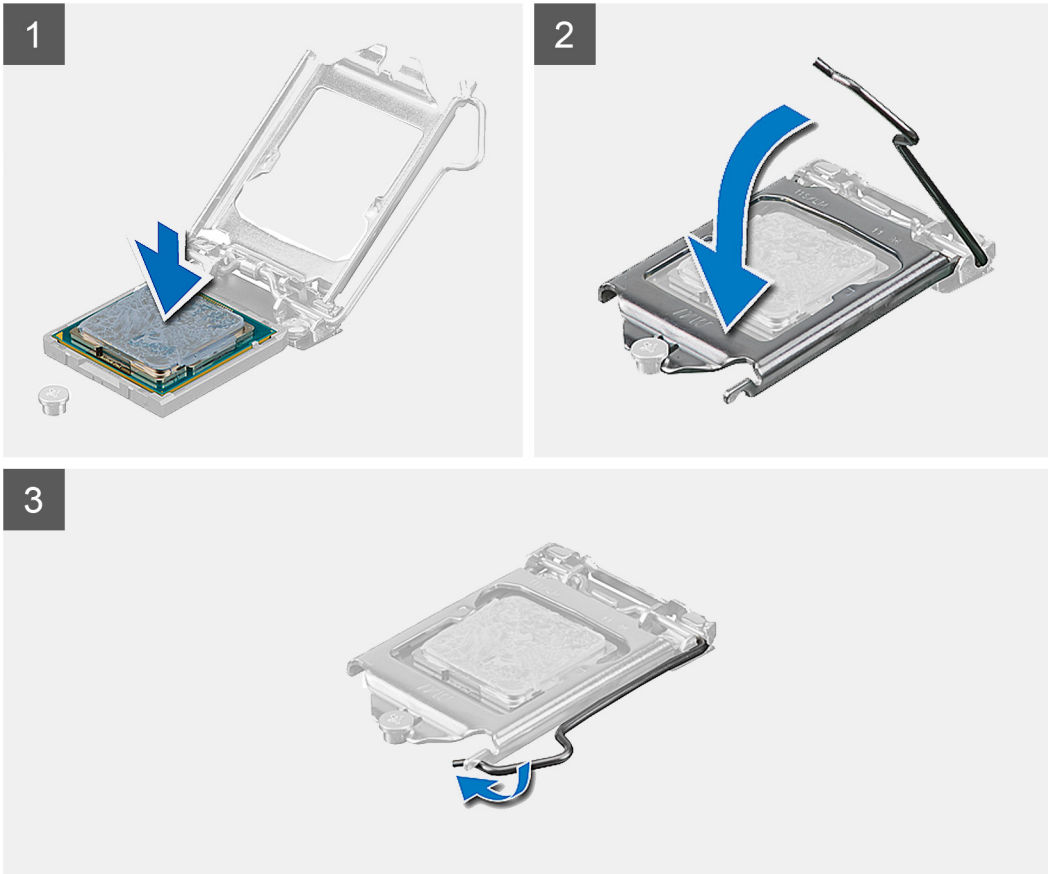
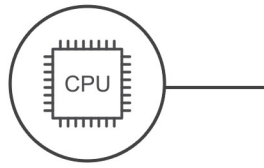

Steps

1. Insert the processor in the processor socket. Ensure the processor is properly seated [1].

 **CAUTION: Do not use force to seat the processor. When the processor is positioned correctly, it engages easily into the socket.**

2. Lower the processor cover [2].
3. Press the release lever down and then move it inward to secure it with the retention hook [3].

Next steps

Next steps

1. Install the [front bezel](#).
2. Install the [side cover](#).
3. Follow the procedure in [After working inside your computer](#).

System board

Removing the system board

Prerequisites

1. Follow the procedure in [Before working inside your computer](#).
2. Remove the [side cover](#).
3. Remove the [front bezel](#)
4. Remove the [M.2 SSD card](#)
5. Remove the [heat sink assembly](#)
6. Remove the [PSU](#)
7. Remove the [memory module](#)
8. Remove the [expansion card](#)
9. Remove the [coin cell battery](#)
10. Remove the [processor](#)

About this task

The following images indicate the location of the system board and provide a visual representation of the removal procedure.





Steps

1. Lift the hard drive caddy support away from the system board
2. Remove the eight screws (6-32xL6.35) and one standoff screw (6-32xL4.8) that secure the system board to the computer [1].
3. Push the system board towards the front of the system

4. Lift the system board away from the chassis

Installing the system board

About this task



9x
6-32



3



4

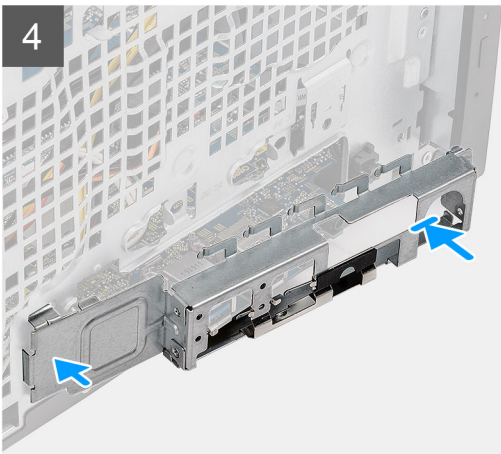

5

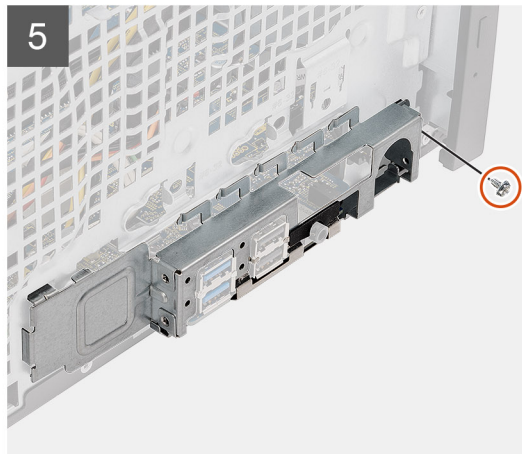

Steps

1. Align and lower the system board into the system until the connectors at the back of the system board align with the slots on the chassis, and the screw holes on the system board align with the standoffs on the system
2. Place the hard drive caddy support on the system board. screws (6-32xL6.35) that secure the system board to the chassis.
3. Place the front IO bracket.

Next steps

Next steps

1. Install the [processor](#)
2. Install the [coin cell battery](#)
3. Install the [PSU](#)
4. Install the [memory module](#)
5. Install the [expansion card](#)
6. Install the [heat sink assembly](#)
7. Install the [M.2 SSD card](#)
8. Install the [front bezel](#)
9. Install the [side cover](#).
10. Follow the procedure in [After working inside your computer](#).

System setup

System setup enables you to manage your tablet/desktop/notebook hardware and specify BIOS level options. From the System setup, you can:

- Change the NVRAM settings after you add or remove hardware.
- View the system hardware configuration.
- Enable or disable integrated devices.
- Set performance and power management thresholds
- Manage your computer security

Topics:

- [BIOS overview](#)
- [Entering BIOS Setup](#)
- [Navigation keys](#)
- [F12 One Time Boot menu](#)
- [Boot Sequence](#)
- [System Setup options](#)
- [Updating the BIOS](#)
- [System and setup password](#)
- [Clearing system and setup passwords](#)

BIOS overview

The BIOS manages data flow between the computer's operating system and attached devices such as hard disk, video adapter, keyboard, mouse, and printer.

Entering BIOS Setup

Steps

1. Turn on your computer.
2. Press F2 immediately to enter the BIOS Setup.

 **NOTE:** If you wait too long and the operating system logo appears, continue to wait until you see the desktop. Then, turn off your computer and try again.

Navigation keys

 **NOTE:** For most of the BIOS Setup options, changes that you make are recorded but do not take effect until you restart the computer.

Table 2. Navigation keys

Keys	Navigation
Up arrow	Moves to the previous field.
Down arrow	Moves to the next field.
Enter	Selects a value in the selected field (if applicable) or follows the link in the field.

Table 2. Navigation keys (continued)

Keys	Navigation
Spacebar	Expands or collapses a drop-down list, if applicable.
Tab	Moves to the next focus area.
Esc	Moves to the previous page until you view the main screen. Pressing Esc in the main screen displays a message that prompts you to save any unsaved changes and restart the computer.

F12 One Time Boot menu

To enter the One Time Boot menu, turn on or restart your computer, and then press F12 immediately.

 **NOTE:** If you are unable to enter the One Time Boot menu, repeat the above action.

The One Time Boot menu displays the devices that you can boot from and also display the options to start diagnostics. The boot menu options are:

- Removable Drive (if available)
- STXXXX Drive (if available)

 **NOTE:** XXX denotes the SATA drive number.

- Optical Drive (if available)
- SATA Hard Drive (if available)
- Diagnostics

The One Time Boot menu screen also displays the option to access BIOS Setup.

Boot Sequence

Boot sequence enables you to bypass the System Setup–defined boot device order and boot directly to a specific device (for example: optical drive or hard drive). During the Power-on Self-Test (POST), when the Dell logo appears, you can:

- Access System Setup by pressing F2 key
- Bring up the one-time boot menu by pressing F12 key.

The one-time boot menu displays the devices that you can boot from including the diagnostic option. The boot menu options are:

- Removable Drive (if available)
- STXXXX Drive

 **NOTE:** XXXX denotes the SATA drive number.

- Optical Drive (if available)
- SATA Hard Drive (if available)
- Diagnostics

 **NOTE:** Choosing **Diagnostics**, displays the **SupportAssist** screen.

The boot sequence screen also displays the option to access the System Setup screen.

System Setup options

 **NOTE:** Depending on the computer and its installed devices, the items listed in this section may or may not appear.

Table 3. General

Option	Description
System Information	<p>Displays the following information:</p> <ul style="list-style-type: none"> • System Information: Displays BIOS Version, Service Tag, Asset Tag, Ownership Date, Manufacture Date, and the Express Service Code. • Memory Information: Displays Memory Installed, Memory Available, Memory Speed, Memory Channels Mode, Memory Technology, DIMM 1 Size, and DIMM 2 Size. • PCI Information: Displays SLOT1, SLOT2, SLOT3, SLOT4, SLOT5_M.2 • Processor Information: Displays Processor Type, Core Count, Processor ID, Current Clock Speed, Minimum Clock Speed, Maximum Clock Speed, Processor L2 Cache, Processor L3 Cache, HT Capable, and 64-Bit Technology. • Device Information: Displays SATA-0, SATA-1, SATA-2, SATA-3, LOM MAC Address, Video Controller
Boot Sequence	<p>Allows you to specify the order in which the computer attempts to find an operating system from the devices specified in this list.</p> <ul style="list-style-type: none"> • UEFI (default)
UEFI Boot Path Security	<p>Options:</p> <ul style="list-style-type: none"> • Always, Except Internal HDD (default) • Always • Never
Date/Time	<p>Allows you to set the date and time settings. Changes to the system date and time take effect immediately.</p>

Table 4. System Configuration

Option	Description
Integrated NIC	<p>Allows you to control the on-board LAN controller. The options are:</p> <ul style="list-style-type: none"> • Enable UEFI Network stack • Disabled • Enabled • Enabled w/PXE (default) <p> NOTE: Depending on the computer and its installed devices, the items listed in this section may or may not appear.</p>
Serial Port	<p>Identifies and defines the serial port settings. You can set the serial port to:</p> <ul style="list-style-type: none"> • Disabled • COM1 (default) • COM2 • COM3 • COM4
SATA Operation	<p>Allows you to configure the operating mode of the integrated hard drive controller.</p> <ul style="list-style-type: none"> • Disabled = The SATA controllers are hidden • AHCI • RAID On (default)
Drives	<p>Allows you to enable or disable the various drives on-board:</p> <ul style="list-style-type: none"> • SATA-0 • SATA-1 • SATA-3 • M.2 PCIe SSD-2 <p>Default Setting: All drives are enabled.</p>
Smart Reporting	<p>This field controls whether hard drive errors for integrated drives are reported during system startup. This option is disabled by default.</p>
USB Configuration	<p>Allows you to enable or disable the integrated USB controller for:</p>

Table 4. System Configuration (continued)

Option	Description
	<ul style="list-style-type: none"> • Enable Boot Support • Enable Front USB Ports • Enable Rear USB Ports <p>All the options are enabled by default.</p>
Front USB Configuration	<p>Allows you to enable or disable the Front USB configuration. The options are:</p> <ul style="list-style-type: none"> • Front Port 1 (Left)* • Front Port 2 (Right)* • Front Port 3 (Left)* • Front Port 4 (Right)* <p>All the options are enabled by default.</p> <p>* denotes a USB 3.0-capable port</p>
Rear USB Configuration	<p>Allows you to enable or disable the rear USB configuration. The options are:</p> <ul style="list-style-type: none"> • Rear Port 1 (Left) • Rear Port 2 (Right) • Rear Port 3 (Left) • Rear Port 4 (Right) <p>All the options are enabled by default.</p> <p>* denotes a USB 3.0-capable port</p>
Audio	<p>Allows you to enable or disable the integrated audio controller.</p> <ul style="list-style-type: none"> • Enable Microphone • Enable Internal Speaker <p>Both the options are enabled by default.</p>
Miscellaneous Devices	<p>Allows you to enable or disable the various on-board devices.</p> <ul style="list-style-type: none"> • Enable PCI Slot (default option)

Table 5. Video

Option	Description
Primary Display	<p>Allows you to select the primary display when multiple controllers are available in the system.</p> <ul style="list-style-type: none"> • Auto (default) • Intel HD Graphics • NVIDIA HD Graphics <p>i NOTE: If you do not select Auto, the on-board graphics device will be present and enabled.</p>
Multi-Display	<p>The option is enabled by default</p>

Table 6. Security

Option	Description
Admin Password	<p>This option lets you enable or disable Admin passwords for the system.</p> <p>i NOTE: You must set the admin password before you set the system or hard drive password. Deleting the admin password automatically deletes the system password and the hard drive password.</p> <p>i NOTE: Successful password changes take effect immediately.</p> <p>Default Setting: Not set</p>

Table 6. Security (continued)





Option	Description
System Password	Allows you to set, change or delete the system password.  NOTE: Successful password changes take effect immediately. Default Setting: Not set
Internal HDD-0 Password	Allows you to set, change or delete the password on the system's internal hard-disk drive.  NOTE: Successful password changes take effect immediately. Default Setting: Not set
Internal HDD-1 Password	Allows you to set, change or delete the password on the system's internal hard-disk drive.  NOTE: Successful password changes take effect immediately. Default Setting: Not set
Internal HDD-3 Password	Allows you to set, change or delete the password on the system's internal hard-disk drive.  NOTE: Successful password changes take effect immediately. Default Setting: Not set
Password Change	Allows you to enable the disable permission to the System and Hard Drive passwords when the admin password is set. Default Setting: Allow Non-Admin Password Changes is selected.
UEFI Capsule Firmware Updates	Allows you to controls whether the system allows BIOS update via UEFI capsule update packages. Default setting: Enable
PTT Security	Allows you to control the Platform Trust Technology feature (PTT) is visible to the operating system. The options are: <ul style="list-style-type: none"> • PTT On  NOTE: Disabling this option dose not change any setting you have made to the PTT nor dose it delete or change any information or keys you may have stored in the PTT. Changes to this settings take effect immediately
Absolute(R)	This field lets you Enable, Disable or Permanently Disable the BIOS module interface of the optional Absolute Persistence Module service from Absolute Software. Enabled (default) Disabled Permanently Disabled
Master Password Lockout	The option is disabled by default
HDD Protection Support	The option is disabled by default
SMM Security Mitigation	The option is disabled by default

Table 7. Secure Boot

Option	Description
Secure Boot Enable	Allows you to enable or disable Secure Boot feature. The option is disabled by default.
Secure Boot Mode	<ul style="list-style-type: none"> • Deployed Mode (default) • Audit Mode
Expert key Management	Allows you to manipulate the security key databases only if the system is in Custom Mode. The Enable Custom Mode option is disabled by default. The options are: <ul style="list-style-type: none"> • PK (default) • KEK

Table 7. Secure Boot (continued)

Option	Description
	<ul style="list-style-type: none"> • db • dbx <p>If you enable the Custom Mode, the relevant options for PK, KEK, db, and dbx appear. The options are:</p> <ul style="list-style-type: none"> • Save to File- Saves the key to a user-selected file • Replace from File- Replaces the current key with a key from a user-selected file • Append from File- Adds a key to the current database from a user-selected file • Delete- Deletes the selected key • Reset All Keys- Resets to default setting • Delete All Keys- Deletes all the keys <p> NOTE: If you disable the Custom Mode, all the changes made will be erased and the keys will restore to default settings.</p>

Table 8. Intel Software Guard Extensions

Option	Description
Intel SGX Enable	<p>Allows you to enable or disable the Intel Software Guard Extensions to provide a secured environment for running code/storing sensitive information in the context of the main operating system.</p> <ul style="list-style-type: none"> • Disabled • Enabled • Software Controlled (default)
Enclave Memory Size	<p>Allows you to set the Intel SGX Enclave Reserve Memory Size.</p> <ul style="list-style-type: none"> • 32 MB • 64 MB • 128 MB

Table 9. Performance

Option	Description
Multi Core Support	This field specifies whether the process will have one or all cores enabled. This option is enabled by default.
Enable Intel SpeedStep	Allows you to enable or disable the Intel SpeedStep mode of the processor. This option is enabled by default.
C States Control	Allows you to enable or disable additional processor sleep states. This option is enabled by default.
Intel TurboBoost	Allows you to enable or disable the Intel TurboBoost mode of the processor. This option is enabled by default.
Hyper-Thread Control	<p>Allows you to enable or disable the HyperThreading in the processor.</p> <ul style="list-style-type: none"> • Disabled • Enabled (default)

Table 10. Power Management

Option	Description
AC Recovery	<p>Determines how the system responds when AC power is re-applied after a power loss. You can set the AC Recovery to:</p> <ul style="list-style-type: none"> • Power Off • Power On • Last Power State <p>This option is Power Off by default.</p>

Table 10. Power Management (continued)

Option	Description
Enable Intel Speed Shift Technology	The option is enabled by default
Auto On Time	Sets time to automatically turn on the computer. Time is kept in standard 12-hour format (hour:minutes:seconds). Change the startup time by typing the values in the time and AM/PM fields.  NOTE: This feature does not work if you turn off your computer using the switch on a power strip or surge protector or if Auto Power is set to disabled .
Deep Sleep Control	Allows you to define the controls when Deep Sleep is enabled. <ul style="list-style-type: none"> ● Disabled (default) ● Enabled in S5 only ● Enabled in S4 and S5 This option is Disabled by default.
USB Wake Support	Allows you to enable the USB devices to wake the computer from standby mode. This option is enabled by default.
Wake on LAN/WLAN	Enables or disables the computer to turn on by a special LAN signal. This option is disabled by default.
Block Sleep	Allows you to block entering to sleep (S3 state) in OS environment. This option is disabled by default.

Table 11. POST Behavior

Option	Description
Numlock LED	Allows you to enable or disable the Numlock feature when your computer starts. This option is enabled by default.
Keyboard Errors	Allows you to enable or disable the keyboard error reporting when the computer starts. This option is enabled by default.
Fast Boot	This option can speed up the boot process by bypassing some compatibility steps: <ul style="list-style-type: none"> ● Minimal — The system boots quickly, unless the BIOS has been updated, memory changed, or the previous POST did not complete. ● Thorough — The system does not skip any steps in the boot process. ● Auto — This allows the operating system to control this setting (this works only when the operating system supports Simple Boot Flag). This option is set to Thorough by default.
Extended BIOS Post Time	<ul style="list-style-type: none"> ● 0 seconds (default) ● 5 seconds ● 10 seconds
Full Screen Logo	The option is disabled by default
Warnings and Errors	<ul style="list-style-type: none"> ● Prompt on Warnings and Errors (default) ● Continue on Warnings and Errors ● Continue on Warnings

Table 12. Virtualization Support

Option	Description
Virtualization	This option specifies whether a Virtual Machine Monitor (VMM) can utilize the additional hardware capabilities provided by Intel® Virtualization Technology. Enable Intel Virtualization Technology - This option is enabled by default.
VT for Direct I/O	This option is enabled by default.

Table 13. Maintenance

Option	Description
Service Tag	Displays the Service Tag of your computer.
Asset Tag	Allows you to create a system asset tag if an asset tag is not already set. This option is not set by default.
SERR Messages	The option is enabled by default
BIOS Downgrade	Allows you to control flashing of the system firmware to the previous versions. This option is enabled by default.  NOTE: If this option is not selected, the flashing of the system firmware to the previous versions is blocked.
Data Wipe	The option is disabled by default
BIOS recovery	Allows you to recover the corrupted BIOS conditions from the recovery files on the primary hard drive or an external USB key.
First Power On Date	This option lets you set ownership date. The option is disabled by default

Table 14. System Logs

Option	Description
BIOS Events	Displays the system event log and allows you to: <ul style="list-style-type: none">• Clear Log• Mark all Entries

Table 15. Advanced configurations

Option	Description
ASPM	<ul style="list-style-type: none">• Auto (default)• Disabled• L1 only

Table 16. SupportAssist System Resolution

Option	Description
Auto OS Recovery Threshold	Allows you to control the automatic boot flow for SupportAssist System. Options are: <ul style="list-style-type: none">• Off• 1• 2 (default)• 3
SupportAssist OS Recovery	Allows you to recover the SupportAssist OS Recovery (Enabled by default)

Updating the BIOS

Updating the BIOS in Windows

About this task

 **CAUTION:** If BitLocker is not suspended before updating the BIOS, the BitLocker key is not recognized the next time you reboot the computer. You will then be prompted to enter the recovery key to proceed, and the computer displays a prompt for the recovery key on each reboot. Failure to provide the recovery key can result in data loss or an operating system reinstall. For more information, see the Knowledge Base Resource [Updating the BIOS on Dell systems with BitLocker enabled](#).

 **CAUTION:** Do not turn off the computer during the BIOS flash update process. The computer may not boot if you turn off your computer.

Steps

1. Go to [Dell Support Site](#).
2. Go to **Identify your product or search support**. In the box, enter the product identifier, model, service request or describe what you are looking for, and then click **Search**.

 **NOTE:** If you do not have the Service Tag, use SupportAssist to automatically identify your computer. You can also use the product ID or manually browse for your computer model.

3. Click **Drivers & Downloads**. Expand **Find drivers**.
4. Select the operating system installed on your computer.
5. In the **Category** drop-down list, select **BIOS**.
6. Select the latest version of BIOS, and click **Download** to download the BIOS file for your computer.
7. After the download is complete, navigate to the folder where the BIOS update file has been saved.
8. Double-click the BIOS update file and follow the on-screen instructions.

For more information, search in the Knowledge Base Resource at [Dell Support Site](#).

Updating the BIOS in Linux and Ubuntu

To update the system BIOS on a computer that is installed with Linux or Ubuntu, see the knowledge base article [000131486](#) at [Dell Support Site](#).

Updating the BIOS using the USB drive in Windows

About this task

 **CAUTION:** If BitLocker is not suspended before updating the BIOS, the BitLocker key is not recognized the next time you reboot the computer. You will then be prompted to enter the recovery key to proceed, and the computer displays a prompt for the recovery key on each reboot. Failure to provide the recovery key can result in data loss or an operating system reinstall. For more information, see the Knowledge Base Resource [Updating the BIOS on Dell systems with BitLocker enabled](#).

 **CAUTION:** Do not turn off the computer during the BIOS flash update process. The computer may not boot if you turn off your computer.

Steps

1. Go to [Dell Support Site](#).
2. Go to **Identify your product or search support**. In the box, enter the product identifier, model, service request or describe what you are looking for, and then click **Search**.

 **NOTE:** If you do not have the Service Tag, use SupportAssist to automatically identify your computer. You can also use the product ID or manually browse for your computer model.

3. Click **Drivers & Downloads**. Expand **Find drivers**.
4. Select the operating system installed on your computer.
5. In the **Category** drop-down list, select **BIOS**.
6. Select the latest version of BIOS, and click **Download** to download the BIOS file for your computer.
7. Create a bootable USB drive. For more information, search in the Knowledge Base Resource at [Dell Support Site](#).
8. Copy the BIOS setup program file to the bootable USB drive.
9. Connect the bootable USB drive to the computer that needs the BIOS update.
10. Restart the computer and press **F12**.
11. Select the USB drive from the **One Time Boot Menu**.
12. Type the BIOS setup program filename and press **Enter**.

The **BIOS Update Utility** appears.

13. Follow the on-screen instructions to complete the BIOS update.

Updating the BIOS from the One-Time boot menu

You can run the BIOS flash update file from Windows using a bootable USB drive or you can also update the BIOS from the One-Time boot menu on the computer. To update your computers BIOS, copy the BIOS XXXX.exe file onto a USB drive formatted with the FAT32 file system. Then, restart your computer and boot from the USB drive using the One-Time Boot Menu.

About this task

 **CAUTION:** If BitLocker is not suspended before updating the BIOS, the BitLocker key is not recognized the next time you reboot the computer. You will then be prompted to enter the recovery key to proceed, and the computer displays a prompt for the recovery key on each reboot. Failure to provide the recovery key can result in data loss or an operating system reinstall. For more information, see the Knowledge Base Resource [Updating the BIOS on Dell systems with BitLocker enabled](#).

To confirm if the BIOS Flash Update is listed as a boot option, you can boot your computer to the **One Time Boot** Menu. If the option is listed, then the BIOS can be updated using this method.

To update your BIOS from the One-Time boot menu, you need the following:

- USB drive formatted to the FAT32 file system (the drive does not have to be bootable)
- BIOS executable file that you downloaded from the Dell Support website and copied to the root of the USB drive
- AC power adapter must be connected to the computer
- For laptops, ensure that the battery is adequately charged before flashing the BIOS.

Perform the following steps to update the BIOS from the One-Time boot menu:

 **CAUTION:** Do not turn off the computer during the BIOS flash update process. The computer may not boot if you turn off your computer.

Steps

1. Turn off the computer and insert the USB drive that contains the BIOS flash update file.
2. Turn on the computer and press **F12** to access the **One Time Boot** Menu. Select **BIOS Update** using the mouse or arrow keys then press Enter.
The flash BIOS menu is displayed.
3. Click **Flash from file**.
4. Select the external USB device.
5. Select the file and double-click the flash target file, and then click **Submit**.
6. Click **Update BIOS**. The computer restarts to flash the BIOS.
7. The computer will restart after the BIOS flash update is completed.

System and setup password

 **CAUTION:** The password features provide a basic level of security for the data on your computer.

 **CAUTION:** Ensure that your computer is locked when it is not in use. Anyone can access the data that is stored on your computer, when left unattended.

Table 17. System and setup password

Password type	Description
System password	Password that you must enter to boot to your operating system.
Setup password	Password that you must enter to access and change the BIOS settings of your computer.

You can create a system password and a setup password to secure your computer.

 **NOTE:** The System and setup password feature is disabled by default.

Assigning a system setup password

Prerequisites

You can assign a new **System or Admin Password** only when the status is in **Not Set**.

About this task

To enter the system setup, press F12 immediately after a power-on or reboot.

Steps

1. In the **System BIOS** or **System Setup** screen, select **Security** and press Enter.
The **Security** screen is displayed.
2. Select **System/Admin Password** and create a password in the **Enter the new password** field.
Use the following guidelines to assign the system password:
 - A password can have up to 32 characters.
 - At least one special character: ! " # \$ % & ' () * + , - . / : ; < = > ? @ [\] ^ _ ` { | }
 - Numbers 0 through 9.
 - Upper case letters from A to Z.
 - Lower case letters from a to z.
3. Type the system password that you entered earlier in the **Confirm new password** field and click **OK**.
4. Press Esc and save the changes as prompted by the pop-up message.
5. Press Y to save the changes.
The computer restarts.

Deleting or changing an existing system password or setup password

Prerequisites

Ensure that the **Password Status** is Unlocked in the System Setup before attempting to delete or change the existing system password and/or setup password. You cannot delete or change an existing system password or setup password if the **Password Status** is Locked. To enter the System Setup, press F2 immediately after a power-on or reboot.

Steps

1. In the **System BIOS** or **System Setup** screen, select **System Security** and press Enter.
The **System Security** screen is displayed.
2. In the **System Security** screen, verify that the **Password Status** is Unlocked.
3. Select **System Password**. Update or delete the existing system password, and press Enter or Tab.
4. Select **Setup Password**. Update or delete the existing setup password, and press Enter or Tab.

 **NOTE:** If you change the system password and/or setup password, reenter the new password when prompted. If you delete the system password and/or setup password, confirm the deletion when prompted.

5. Press Esc. A message prompts you to save the changes.
6. Press Y to save the changes and exit from **System Setup**.
The computer restarts.

Clearing system and setup passwords

About this task

To clear the system or setup passwords, contact Dell technical support as described at [Contact Support](#).

 **NOTE:** For information about how to reset Windows or application passwords, see the documentation accompanying Windows or your application.

Troubleshooting

Topics:

- [EC Diag LED Behavior](#)
- [Dell Enhanced Pre-Boot System Assessment — ePSA Diagnostic 3.0](#)
- [System error messages](#)
- [Recovering the operating system](#)
- [Real-Time Clock \(RTC Reset\)](#)
- [Backup media and recovery options](#)
- [Network power cycle](#)

EC Diag LED Behavior

EC Diag LED Behavior

The following table depicts the amber and white blinking patterns with possible troubleshooting resolution:

Table 18. LED Behavior

Blinking pattern		Problem Description	Suggested Resolution
Amber	White		
1	2	Unrecoverable SPI Flash Failure	Run the Intel CPU diagnostics tools If problem persists, replace the system board
2	1	CPU failure	Run the Intel CPU diagnostics tools If problem persists, replace the system board
2	2	System board failure (included BIOS corruption or ROM error)	Flash latest BIOS version
2	3	No memory/ RAM detected	Confirm that the memory module is installed properly If problem persists, replace the memory module
2	4	Memory/ RAM failure	Reset the memory module
2	5	Invalid memory installed	Reset the memory module If problem persists, replace the memory module
2	6	System board / Chipset Error / Clock failure / Gate A20 failure / Super I/O failure / Keyboard controller failure	Flash latest BIOS version If problem persists, replace the LCD module

Table 18. LED Behavior (continued)

Blinking pattern		Problem Description	Suggested Resolution
Amber	White		
3	1	CMOS battery failure	Reset the CMOS battery connection If problem persists, replace the RTS battery
3	2	PCI or Video card/ chip failure	<ol style="list-style-type: none"> 1. Check if the display in operating system is functioning appropriately or not. If the display is appropriate, the customer has to update the latest BIOS (v1.3.2 or above). 2. Check the customer's platform configuration if there is no display in operating system. <ol style="list-style-type: none"> a. If video card is used to display, replace video card. b. If UMA is used to display, replace the CPU. c. If (a) and (b) does not work, replace the system board. d. After the display problem is fixed, the customer must update latest BIOS (v1.3.2 or above).
3	3	Recovery Image not found	Flash latest BIOS version If problem persists, replace the system board
3	4	Recovery Image found but invalid	Flash latest BIOS version If problem persists, replace the system board
3	5	Power Rail Failure	EC ran into power sequencing failure If problem persists, replace the system board
3	6	Paired SPI Volume Error	Flash corruption detected by SBIOS If problem persists, replace the system board
3	7	Intel ME (Management Engine) Error	Timeout waiting on ME to reply to ECI message If problem persists, replace the system board
4	2	CPU Power Cable Connection Issue	Timeout waiting on ME to reply to ECI message If problem persists, replace the system board

Dell Enhanced Pre-Boot System Assessment — ePSA Diagnostic 3.0

You can invoke the ePSA diagnostics by either of the following ways :

- Press the F12 key when the system posts and choose **ePSA or Diagnostics** option on One Time Boot Menu.
- Press and hold Fn(Function key on keyboard) and **Power On** (PWR) the system.

For more details, see [Dell EPSA Diagnostic 3.0](#).

System error messages

Table 19. System error messages

System message	Description
Alert! Previous attempts at booting this system have failed at checkpoint [nnnn]. For help in resolving this problem, please note this checkpoint and contact Dell Technical Support	The computer failed to complete the boot routine three consecutive times for the same error.
CMOS checksum error	RTC is reset, BIOS Setup default has been loaded.
CPU fan failure	CPU fan has failed.
System fan failure	System fan has failed.
Hard-disk drive failure	Possible hard disk drive failure during POST.
Keyboard failure	Keyboard failure or loose cable. If reseating the cable does not solve the problem, replace the keyboard.
No boot device available	No bootable partition on hard disk drive, the hard disk drive cable is loose, or no bootable device exists. <ul style="list-style-type: none">• If the hard drive is your boot device, ensure that the cables are connected and that the drive is installed properly and partitioned as a boot device.• Enter system setup and ensure that the boot sequence information is correct.
No timer tick interrupt	A chip on the system board might be malfunctioning or motherboard failure.
NOTICE - Hard Drive SELF MONITORING SYSTEM has reported that a parameter has exceeded its normal operating range. Dell recommends that you back up your data regularly. A parameter out of range may or may not indicate a potential hard drive problem	S.M.A.R.T error, possible hard disk drive failure.

Recovering the operating system

When your computer is unable to boot to the operating system even after repeated attempts, it automatically starts Dell SupportAssist OS Recovery.

Dell SupportAssist OS Recovery is a stand-alone tool that is preinstalled on Dell computers running the Windows operating system. It consists of tools to diagnose and troubleshoot issues that may occur before your computer boots to the operating system. It enables you to diagnose hardware issues, repair your computer, back up your files, and restore your computer to its factory state.

You can also download it from the Dell Support website to troubleshoot and fix your computer when it fails to boot into the primary operating system due to software or hardware failures.

For more information about the Dell SupportAssist OS Recovery, see *Dell SupportAssist OS Recovery User's Guide at Serviceability Tools at the Dell Support Site*. Click **SupportAssist** and then click **SupportAssist OS Recovery**.

NOTE: Windows 11 IoT Enterprise LTSC 2024 and Dell ThinOS 10 do not support Dell SupportAssist. For more information about recovering ThinOS 10, see [Recovery mode using R-Key](#).

Real-Time Clock (RTC Reset)

The Real Time Clock (RTC) reset function allows you or the service technician to recover Dell Inspiron, systems from No POST/No Power/No Boot situations. The legacy jumper enabled RTC reset has been retired on these models.

Start the RTC reset with the system powered off and connected to AC power. Press and hold the power button for thirty (30) seconds. The system RTC Reset occurs after you release the power button.

Backup media and recovery options

It is recommended to create a recovery drive to troubleshoot and fix problems that may occur with Windows. Dell provides multiple options for recovering the Windows operating system on your Dell computer. For more information, see [Dell Windows Backup Media and Recovery Options](#).

Network power cycle

About this task

If your computer is unable to access the Internet due to network connectivity issues, reset your network devices by performing the following steps:

Steps



1. Turn off the computer.
2. Turn off the modem.
NOTE: Some Internet service providers (ISPs) provide a modem and router combo device.
3. Turn off the wireless router.
4. Wait for 30 seconds.
5. Turn on the wireless router.
6. Turn on the modem.
7. Turn on the computer.

Getting help and contacting Dell Technologies

Self-help resources

You can get information and help on Dell Technologies products and services using these self-help resources:

Table 20. Self-help resources

Self-help resources	Resource location
Information about Dell Technologies products and services	Dell Site
MyDell app	
Tips	
Contact Support	In Windows search, type <code>Contact Support</code> , and press Enter.
Online help for operating system	Windows Support Site
Access top solutions, diagnostics, drivers and downloads, and learn more about your computer through videos, manuals, and documents.	Your Dell Technologies computer is uniquely identified using a Service Tag or Express Service Code. To view relevant support resources for your Dell Technologies computer, enter the Service Tag or Express Service Code at Dell Support Site . For more information about how to find the Service Tag for your computer, see Instructions on how to find your Service Tag or Serial Number .
Dell Technologies knowledge base articles	<ol style="list-style-type: none"> 1. Go to Dell Support Site. 2. On the menu bar at the top of the Support page, select Support > Support Library. 3. In the Search field on the Support Library page, type the keyword, topic, or model number, and then click or tap the search icon to view the related articles.

Contacting Dell Technologies

To contact Dell Technologies for sales, technical support, or customer service issues, see [Contact Support at Dell Support Site](#).

 **NOTE:** Availability of the services may vary depending on the country or region, and product.

 **NOTE:** If you do not have an active Internet connection, you can find contact information about your purchase invoice, packing slip, bill, or Dell Technologies product catalog.