

Dell EMC Boot Optimized Server Storage-S1

User's Guide

Notes, cautions, and warnings

 **NOTE:** A NOTE indicates important information that helps you make better use of your product.

 **CAUTION:** A CAUTION indicates either potential damage to hardware or loss of data and tells you how to avoid the problem.

 **WARNING:** A WARNING indicates a potential for property damage, personal injury, or death.

© 2017 - 2019 Dell Inc. or its subsidiaries. All rights reserved. Dell, EMC, and other trademarks are trademarks of Dell Inc. or its subsidiaries. Other trademarks may be trademarks of their respective owners.

1 Overview	5
Supported operating systems	6
Supported PowerEdge systems	6
BOSS-S1 card specifications	7
Supported M.2 drives	7
Management applications for the BOSS-S1 controller	8
Update the BOSS-S1 controller	8
Update the BOSS-S1 firmware	8
Firmware update using an operating system-specific DUP	8
Firmware update using Windows DUP	9
Firmware update using Linux DUP	9
Firmware update using UEFI Shell	9
Firmware update using BOSS-S1 CLI	9
Firmware update using Windows	9
Firmware update using Linux	10
Firmware update using iDRAC	10
Firmware update using Lifecycle Controller	11
Related documentation	11
2 Features	12
Foreign import	12
SMART info	12
Auto-rebuild	12
Non-RAID disk support	13
TRIM	13
Quick initialization	13
Erase physical disk	13
3 Deploying the BOSS-S1 card	14
Removing the BOSS-S1 card	14
Removing the M.2 SSD module from the BOSS-S1 card	15
Installing the M.2 SSD module on BOSS-S1 card	16
Installing the BOSS-S1 card	17
4 Driver installation	19
5 UEFI or HII RAID configuration utility	20
Entering the UEFI configuration utility	20
Exiting the UEFI configuration utility	20
Entering the BOSS-S1 configuration utility	20
Physical or virtual disk information	21
Physical disk information	21
Virtual disk information	21
Virtual disk import	21

Creating a virtual disk.....	21
Deleting virtual disks.....	22
RAID rebuild.....	22
Erase physical disk.....	22
Controller information.....	22
Clear controller configuration.....	22
6 BOSS-S1 CLI commands.....	23
Using CLI commands from Windows.....	23
Using CLI commands from Linux.....	23
Using CLI commands from ESXi.....	23
Supported BOSS-S1 CLI commands.....	24
7 Troubleshooting.....	25
ROM version for BOSS reported as firmware version in iDRAC interface.....	25
Firmware update of M.2 drive on BOSS-S1 controller fails.....	25
BOSS-S1 CLI displays No Adapter Found error in Linux.....	25
LC log displays fan unavailability error.....	26
Updating BOSS-S1 controller firmware using iDRAC or LC fails.....	26
Physical disk size not updated in iDRAC.....	26
Physical disk/Virtual disk missing in iDRAC.....	26
Back Ground Activity task progress in HII does not report real-time status.....	26
Virtual disk state will be generated twice.....	27
Character limitation while naming a virtual disk.....	27
VMFS datastore is disabled on the 14th generation of PowerEdge systems that are shipped with VMware ESXi installed on BOSS-S1.....	27
Physical disk not visible to operating system.....	27
Virtual disk not visible to operating system.....	27
Drive replacement.....	27
Controller replacement.....	28
Controller failure.....	28
Unable to boot to M.2 drive installed in slot 1.....	28
CLI reports unsupported features.....	28
Failure to install ESXi on RAID 1.....	28
System not responding.....	29
Management port not responding.....	29
8 Getting help.....	30
Contacting Dell EMC.....	30
Documentation feedback.....	30

Overview

BOSS-S1 is a simple RAID solution card designed specifically for booting a server's operating system. The card supports up to two 6 Gbps M.2 SATA drives. The BOSS-S1 adapter card has a x8 connector using PCIe gen 2.0 x2 lanes, available only in the low-profile and full-height form factors. The BOSS-S1 modular card has a dedicated slot in modular servers.

NOTE: BOSS-S1 card allows you to create only one virtual disk from the available physical disks. Specifying the size of a virtual disk is not supported.

NOTE: There are no status LEDs on the BOSS-S1 card.

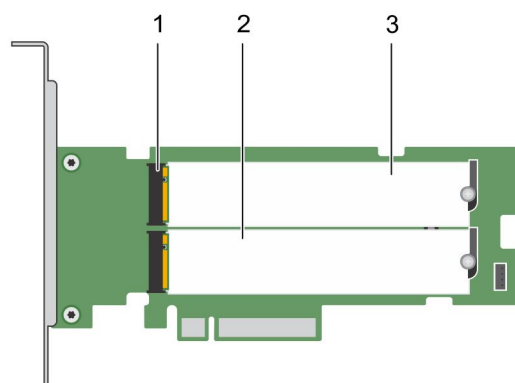

Figure 1. Features of the BOSS-S1 adaptercard

1. SATA drive connector (2)
2. 80 mm M.2 SATA drive 1
3. 80 mm M.2 SATA drive 2

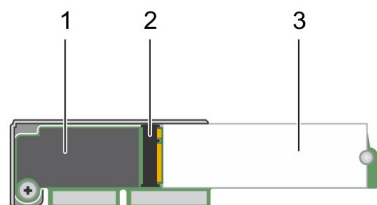

Figure 2. Features of the BOSS-S1 modular card

1. Modular BOSS-S1 card
2. SATA drive connector
3. 80 mm M.2 SATA drive

Topics:

- [Supported operating systems](#)
- [Supported PowerEdge systems](#)
- [BOSS-S1 card specifications](#)
- [Supported M.2 drives](#)
- [Management applications for the BOSS-S1 controller](#)

- [Update the BOSS-S1 controller](#)
- [Update the BOSS-S1 firmware](#)
- [Firmware update using an operating system-specific DUP](#)
- [Firmware update using UEFI Shell](#)
- [Firmware update using BOSS-S1 CLI](#)
- [Firmware update using iDRAC](#)
- [Firmware update using Lifecycle Controller](#)
- [Related documentation](#)

Supported operating systems

The BOSS-S1 card supports the following operating systems:

- Microsoft
 - [Windows Server 2019](#)
 - [Windows Server 2016](#)
 - [Windows Server 2012 R2](#)
- Linux
 - [Red Hat Enterprise Linux version 8.0](#)
 - [Red Hat Enterprise Linux version 7.6](#)
 - [Red Hat Enterprise Linux version 7.5](#)
 - [Red Hat Enterprise Linux version 7.4](#)
 - [Red Hat Enterprise Linux version 6.10](#)
 - [Red Hat Enterprise Linux version 6.9](#)
 - [SUSE Linux Enterprise Server version 15 SP1](#)
 - [SUSE Linux Enterprise Server version 15](#)
 - [SUSE Linux Enterprise Server version 12 SP3](#)
 - [Ubuntu 18.04](#)
 - [Ubuntu 16.04](#)
- VMware
 - [ESXi 6.0 Update 3](#)
 - [ESXi 6.5 Update 3](#)
 - [ESXi 6.5 Update 2](#)
 - [ESXi 6.5 Update 1](#)
 - [ESXi 6.7 Update 3](#)
 - [ESXi 6.7 Update 2](#)
 - [ESXi 6.7 Update 1](#)
 - [ESXi 6.7](#)

NOTE: For the latest list of supported operating systems and driver installation instructions, see the operating system documentation at www.dell.com/operatingsystemmanuals. For specific operating system service pack requirements, see the Drivers and Downloads section at www.dell.com/manuals.

Supported PowerEdge systems

The following PowerEdge systems support the BOSS-S1 adapter card:

- [PowerEdge C4140](#)
- [PowerEdge C6525](#)
- [PowerEdge R240](#)
- [PowerEdge R340](#)
- [PowerEdge R440](#)
- [PowerEdge R540](#)
- [PowerEdge R540xd](#)
- [PowerEdge R640](#)
- [PowerEdge R740](#)
- [PowerEdge R740xd](#)

- PowerEdge R940
- PowerEdge R6415
- PowerEdge R7415
- PowerEdge R7425
- PowerEdge R6515
- PowerEdge R6525
- PowerEdge R7515
- PowerEdge T140
- PowerEdge T340
- PowerEdge T440
- PowerEdge T640

The following PowerEdge systems support the BOSS-S1 modular card:

- PowerEdge C6420
- PowerEdge FC640
- PowerEdge M640 (for M1000e)
- PowerEdge M640 (for VRTX)
- PowerEdge MX840c
- PowerEdge MX740c

BOSS-S1 card specifications

The following table lists the BOSS-S1 card feature specifications:

Table 1. BOSS-S1 card feature specifications

Feature	BOSS-S1 card
RAID levels	RAID 1
Stripe size	Supports default 64K stripe size only
Battery backup unit	No
Non-volatile cache	No
Virtual disk cache function	Write through
Maximum number of virtual disks	1
Maximum number of drives supported	2
Support for Non-RAID disks	Yes (supports up to two disks)
Drive types	6 Gbps M.2 SATA SSDs
PCIe support	Gen 2
Disk cache policy	Drive default
TRIM	Non-RAID mode

Supported M.2 drives

The BOSS-S1 card supports the following M.2 drives:

Table 2. BOSS-S1 card supported M.2 drives



Drive Model	Capacity
Intel M.2 S4510	240 GB, 480 GB
Intel M.2 S3520	120 GB, 240 GB, 480 GB
Micron M.2 5100	240 GB, 480 GB

 **NOTE:** Dell EMC recommends that you use the BOSS-S1 card only as an operating system boot device.

 **NOTE:** Ensure that M.2 drives have the latest firmware. You can download the latest firmware from www.dell.com/support/home.

Management applications for the BOSS-S1 controller

Management applications enable you to manage and configure the RAID system, create and manage the disk group, and provide online maintenance. The management applications for BOSS-S1 card include:

- **Unified Extensible Firmware Interface (UEFI) RAID Configuration Utility**—This storage management application is integrated into the system BIOS (F2). See [UEFI/HII RAID configuration utility](#).
- **Dell OpenManage Storage Management**—This application enables you to perform controller and enclosure functions for all supported RAID controllers and enclosures from a single graphical or command-line interface. For more information, see the *Dell OpenManage Storage Management User's Guide* at www.dell.com/openmanagemanuals.
- **BOSS-S1 Command Line Interface (CLI) Utility**—This application enables you to check controller, physical disk and virtual disk status while booted to an operating system. The application is also used to check SMART information of the physical disks and display controller. Windows systems use the mvsetup utility while Linux systems use the mvcli utility. The BOSS-S1 CLI Utility also supports ESXi. For more information about CLI commands, see [BOSS-S1 CLI commands](#).
 -  **NOTE:** To use the mvsetup Windows utility, the BOSS-S1 management driver must first be installed. You can download the latest Windows driver from www.dell.com/support/home Linux/ESXi mvcli does not require a driver.
 -  **NOTE:** To remove mvcli from operating systems, uninstall BOSS-S1 drivers from the operating systems or remove the libraries and the executable files.
 -  **NOTE:** Systems Management through iDRAC/LC is not enabled in the firmware version A00. It is available in A01 and later versions.
- **iDRAC and LC**—This application enables you to effectively monitor the RAID and network controllers installed on the system using iDRAC and LC without an operating system installed on the system. For more information, see the *Integrated Dell Remote Access Controller 9 User's Guide* at www.dell.com/idracmanuals.

Update the BOSS-S1 controller

 **CAUTION:** Ensure that you have installed the latest firmware version available at Dell.com/support.

You can update controller firmware using Lifecycle Controller (LC), iDRAC, or UEFI shell. The controller firmware can be updated using the BOSS-S1 command line interface (CLI) utility and Dell Update Package (DUP) when booted to an operating system. You can download the latest DUP and BOSS-S1 CLI from www.dell.com/support/home.

Update the BOSS-S1 firmware

BOSS-S1 card firmware updates can be done using the following methods:

- operating system Dell Update Packages
- UEFI Shell
- BOSS-S1 CLI
- iDRAC
- Lifecycle Controller

Firmware update using an operating system-specific DUP

Download the latest operating system Dell Update Package (DUP) from **SAS-RAID_Firmware_XXXXX_XXXX_XXX.exe** for Windows and **SAS-RAID_Firmware_XXXXX_XXXX_XXX.bin** for Linux from www.dell.com/support/home and install it for monolithic servers.

Download the latest modular operating system DUP from **SAS-RAID_Firmware_XXXXX_XXXX_XXX.exe** for Windows and **SAS-RAID_Firmware_XXXXX_XXXX_XXX.bin** for Linux from www.dell.com/support/home and install it.

Firmware update using Windows DUP

Perform the following steps to update using Windows:

NOTE: Ensure that you have Administrator privileges for Windows.

1. Download the latest Dell Update Package (DUP) for Windows from the www.dell.com/support/home.
2. Double-click the EXE file and click **Install**.
After the inventory collection and firmware validation processes are complete, the installed version and package version are displayed.
NOTE: *Installed version* refers to the current firmware version of the controller, and *package version* refers to the DUP version.
3. Click **Yes** to continue.
4. Click **Yes**.
5. Verify the installed firmware version in HII or using BOSS-S1 CLI.

Firmware update using Linux DUP

Perform the following steps to update using Linux:

NOTE: Ensure that you have Root/Sudo privileges for Linux/ESXi.

1. Download the latest Dell Update Package (DUP) for Linux from the www.dell.com/support/home.
2. Go to the downloaded file path and provide the permissions to execute the DUP file.
3. Execute the BIN file **./SAS-RAID_Firmware_XXXXX_XXXX_XXX.bin**.
4. When prompted, press Q to proceed.
After the inventory collection and firmware validation processes are complete, the installed version and package version are displayed.
5. To continue press **Y+Enter** or **N+Enter** to cancel.
6. Press **Y+Enter** when prompted.
7. Verify the installed firmware version in HII, iDRAC or BOSS-S1 CLI.

Firmware update using UEFI Shell

Perform the following steps to update your firmware using UEFI Shell:

1. Download the **SAS-RAID_Firmware_XXXXX_UEFI_Axx.zip** from www.dell.com/support/home and unzip the file.
2. Copy the files onto a UEFI bootable USB drive and map it to the system.
3. Reboot the system from the USB drive, and go to UEFI.
4. Type the command **fs0:/fs1:** to enter the file system and locate the file.
NOTE: File system partitions may vary depending on your system configuration. Browse through the fsx to locate the USB disk.
5. Run the file **run.nsh** to flash the firmware.
6. On successful update of firmware type **Exit** to exit from the UEFI shell and reboot the system.
7. Verify the installed firmware version in HII, iDRAC or BOSS-S1 CLI.

Firmware update using BOSS-S1 CLI

Download the appropriate CLI application file from www.dell.com/support/home for your Windows or Linux operating system.

Firmware update using Windows

Following are the steps to update the firmware using the BOSS-S1 command line interface.

1. Download the **SAS-RAID_Firmware_XXXXX_UEFI_Axx.zip** from www.dell.com/support/home and extract the zip file.

2. Open the **vs2015/windows** folder. Example: **C:\Desktop\mvsetup.xxxxx_Axx\windows\x64\cli**
3. Copy the firmware image binary from the **SAS-RAID_Firmware_xxxxx_UEFI_Axx.zip** folder to the directory where CLI file is located. Overwrite any existing files.

NOTE: BOSS-S1 supports multiple sub device ID. Locate the correct sub device ID which is available in the iDRAC, BOSS-S1 HII, and BOSS-S1 OS CLI (Info -o hba).

Table 3. Supported SubDevice ID

SubDevice ID	Firmware Binary Link
1FD6 (Monolithic)	ImageA1_1FD6.bin
1FE2 (Monolithic)	ImageA1_1FE2.bin
1FDF (Modular)	ImageA1.bin

4. Run **mvsetup.exe**.
5. To flash the firmware, run the command `flash -a update -f ImageA1_xxxx.bin -t raw` in the CLI shell.
6. Exit and reboot the system, and verify the firmware version.

NOTE: Administrator privileges for Windows and Root/Sudo for Linux are recommended.

Firmware update using Linux

Perform the following steps to update your firmware using the Linux BOSS-S1 command line interface (CLI):

1. Download the **SAS-RAID_Firmware_xxxxx_UEFI_Axx.zip** from www.dell.com/support/home.
2. Locate the folder which contains the downloaded the CLI file, for example: **C:\Home\Desktop\mvcli.xxxx_Axx\x64\cli**.
3. Copy the firmware image binary from the **SAS-RAID_Firmware_xxxxx_UEFI_Axx.zip** folder to the directory where the CLI file is located. Overwrite any existing files.

NOTE: The BOSS-S1 card supports multiple subdevice IDs. Locate the correct subdevice ID, available in the iDRAC, BOSS-S1 HII, and BOSS-S1 operating system CLI (Info -o hba).

Table 4. Supported SubDevice ID

SubDevice ID	Firmware Binary Image
1FD6 (Monolithic)	ImageA1_1FD6.bin
1FE2 (Monolithic)	ImageA1_1FE2.bin
1FDF (Modular)	ImageA1.bin

4. Provide user permissions to that entire folder.
5. To install BOSS-S1, run `./install.sh`, followed by `./mvcli`.
6. To flash the firmware, run the command `flash -a update -f ImageA1_xxxx.bin -t raw` in the CLI shell.
7. Exit and reboot the system, and verify the firmware version.

NOTE: Administrator privileges for Windows and Root/Sudo for Linux are recommended.

Firmware update using iDRAC

To update the firmware using the iDRAC web interface:

1. Download the latest DUP **SAS- RAID_Firmware_xxxxx_xxxx_xxx.exe** from the www.dell.com/support/home.
2. Enter the iDRAC web interface and click on the **Maintenance**.
3. Click **System Update**.
4. Select the EXE Dell Update Package (DUP).
5. Upload the file, and then click **Install > Reboot**.
6. Log in and verify the installed firmware version in HII, iDRAC, or BOSS-S1 CLI.

Firmware update using Lifecycle Controller

To update the firmware using the Lifecycle Controller:

1. Download the DUP file from the www.dell.com/support/home and copy the .exe DUP file to a local drive.
Example of the file name: SAS- RAID_Firmware_XXXXX_XXXX_XXX.exe.
2. Open Virtual Console and boot into Lifecycle Controller by pressing F10 at boot time.
3. Select **Get the Latest firmware** on the dashboard window.
4. Select **Local Drive (CD/DVD/USB)**.
Enter the name of EXE file and select **Update**.
5. After successful installation, reboot and verify the installed firmware version in the HII, iDRAC, or BOSS-S1 CLI.
 - NOTE:** BOSS-S1 firmware update through iDRAC/Lifecycle Controller is supported only on firmware version A01 and above. For more information see [Updating BOSS-S1 controller firmware using iDRAC or LC fails](#).
 - NOTE:** For Information on how to update using the CLI, see [BOSS-S1 CLI commands](#).

Related documentation

NOTE:

- For all storage controllers and PCIe SSD documents, go to www.dell.com/storagecontrollermanuals.
- For all Dell OpenManage documents, go to www.dell.com/openmanagemanuals.
- For all operating system documents, go to www.dell.com/operatingsystemmanuals.
- For all PowerEdge documentation, go to www.dell.com/poweredgemanuals.

Features

The BOSS-S1 card supports the following features:

Topics:

- [Foreign import](#)
- [SMART info](#)
- [Auto-rebuild](#)
- [Non-RAID disk support](#)
- [TRIM](#)
- [Quick initialization](#)
- [Erase physical disk](#)

Foreign import

A virtual disk is considered foreign if it is not native to the adapter.

- A virtual disk is considered native to the adapter if:
 - the virtual disk was created or imported on the adapter.
- A physical disk is considered native to the adapter if:
 - There is no previous virtual disk metadata on the adapter and the physical disk are unconfigured.
 - When the virtual disk corresponding to the physical disks is deleted

The system must be rebooted after performing foreign import.

To check for previous virtual disk metadata, see [Controller Information](#). Only a virtual disk or physical disk native to the adapter will be presented to the operating system.

Upon migrating two foreign drives to a controller, you must do either of the following:

- Clear the controller configuration if using unconfigured drives — [Clear Controller Configuration](#).
- Import the virtual disk if using configured drives — [Virtual Disk Import](#).

SMART info

SMART monitors certain physical aspects of the disk electronics to help detect predictable disk failures. Data on SMART-compliant physical disks can be monitored to identify changes in values and determine whether the values are within the threshold limits. Any electrical failures in the disk can cause degradation in the performance before failure.

A SMART failure is also referred to as a predicted failure. There are numerous factors that predict physical disk failures, such as a read error rate, throughput performance, and changes in spin-up time. In addition, there are factors related to read/write surface failure, such as seek error rate and excessive bad blocks.

 **NOTE: The BOSS-S1 CLI displays error messages with the status OK and NOT OK along with smart attributes.**

Auto-rebuild

A virtual disk rebuild will begin on system boot automatically if the native virtual disk is degraded and a valid rebuild target is present. A valid rebuild target is any functional drive attached to the BOSS-S1 device which is not part of the native virtual disk and is of equal or greater storage capacity. An auto-rebuild occurs without prompting the user, and any data on the rebuild target is overwritten.

Non-RAID disk support

By default, all disks are in an unconfigured state.

NOTE:

- **For the BOSS-S1 card, unconfigured drives are automatically non-RAID drives. To convert RAID drives to non-RAID drives, delete the virtual disk.**
- **The BOSS-S1 only supports one configured (RAID) and two unconfigured states. The BOSS-S1 card does not break unconfigured drives into RAID and non-RAID states.**

TRIM

TRIM (Non-RAID physical disk) allows an operating system to delete a block of data that is no longer considered in use by SSDs. For supported operating systems, the TRIM command resolves the write amplification issue. When an operating system deletes a file, the file is marked for deletion in the file system, but the contents on the disk are not actually erased. As a result, the SSDs do not know the Logical Block Addressing (LBA) previously occupied can be erased. With the introduction of TRIM, when a file is deleted, the operating system sends a TRIM command along with the LBAs that do not contain valid data to the physical disk.

Quick initialization

Quick initialization is a feature that enables you to erase the files and file systems from the virtual disk while keeping the virtual disk configuration intact.

Erase physical disk

The erase physical disk feature deletes metadata from the physical disk. This feature can be enabled only when the physical disk is not part of any virtual disk.

 **CAUTION: Performing erase physical disk removes all the data from the physical disk.**

Deploying the BOSS-S1 card

This section provides a set of high-level installation and removal instructions for the BOSS-S1 card.

Topics:

- [Removing the BOSS-S1 card](#)
- [Installing the BOSS-S1 card](#)

Removing the BOSS-S1 card

CAUTION: Many repairs may only be done by a certified service technician. You should only perform troubleshooting and simple repairs as authorized in your product documentation, or as directed by the online or telephone service and support team. Damage due to servicing that is not authorized by Dell is not covered by your warranty. Read and follow the safety instructions that are shipped with your product.

1. Turn off the system, including any attached peripherals, and disconnect the system from the electrical outlet and peripherals.

NOTE: It is recommended that you always use a static mat and static strap while working on components in the interior of the system.

2. Open the system.
3. Locate the BOSS-S1 card on the system board.

CAUTION: To prevent damage to the card, hold the card by its edges only.

4. If you are removing a BOSS-S1 modular card, loosen the screw that secures the card to the system board.
5. After ensuring that the PCIe bracket is unobstructed, lift the card to remove it from the connector on the system board.

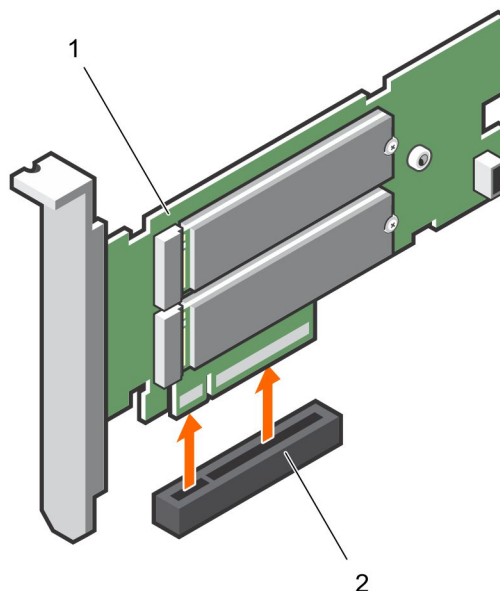

Figure 3. Removing the BOSS-S1 adapter card

- a. BOSS-S1 adapter card
- b. card connector on the system board

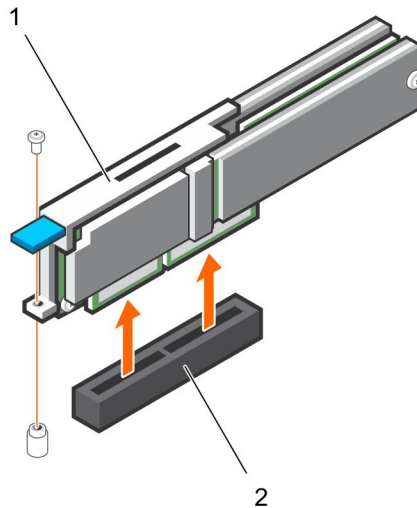

Figure 4. Removing the BOSS-S1 modular card

- a. BOSS-S1 modular card
- b. card connector on the system board

Removing the M.2 SSD module from the BOSS-S1 card

CAUTION: Many repairs may only be done by a certified service technician. You should only perform troubleshooting and simple repairs as authorized in your product documentation, or as directed by the online or telephone service and support team. Damage due to servicing that is not authorized by Dell is not covered by your warranty. Read and follow the safety instructions that are shipped with your product.

1. Turn off the system, including any attached peripherals, and disconnect the system from the electrical outlet and peripherals.

NOTE: It is recommended that you always use a static mat and static strap while working on components in the interior of the system.

2. Open the system.
3. Remove the BOSS-S1 card from the system. See [Removing the BOSS-S1 card](#).
4. Remove the screw that secures the M.2 SSD module to the BOSS-S1 card.
5. Slide and remove the M.2 SSD module away from the card.

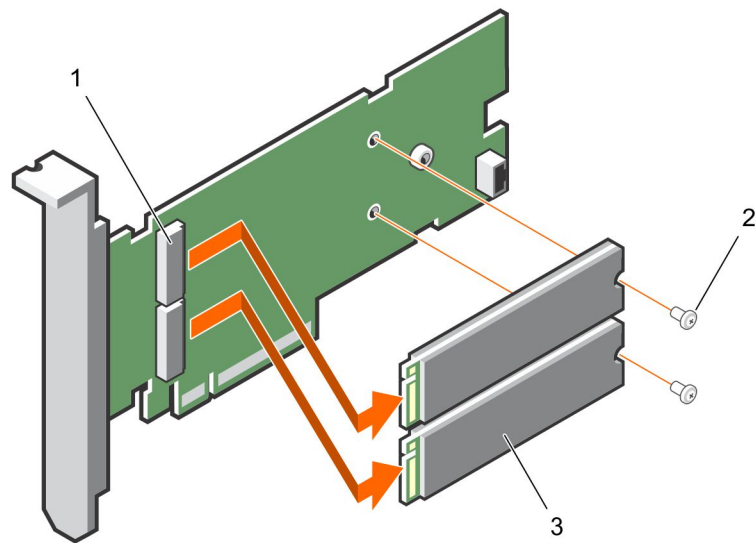

Figure 5. Removing the M.2 SSD module from the BOSS-S1 adapter card

- a. module connector (2)
- b. screw (2)
- c. M.2 SSD module (2)

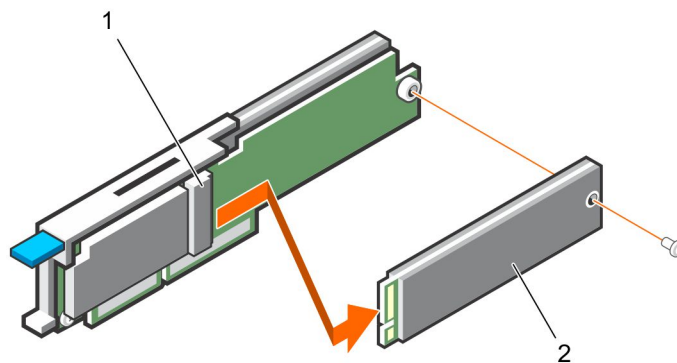

Figure 6. Removing the M.2 SSD module from the BOSS-S1 modular card

- a. module connector
- b. M.2 SSD module

Installing the M.2 SSD module on BOSS-S1 card

CAUTION: Many repairs may only be done by a certified service technician. You should only perform troubleshooting and simple repairs as authorized in your product documentation, or as directed by the online or telephone service and support team. Damage due to servicing that is not authorized by Dell is not covered by your warranty. Read and follow the safety instructions that are shipped with your product.

1. Align the M.2 SSD module connectors with the connectors on the card.
2. Tilt the M.2 SSD module downwards until the module is seated firmly on the card.
3. **CAUTION:** To avoid damage to the card, ensure that you do not over tighten the screw.

Tighten the screw to secure the M.2 SSD module to the card.

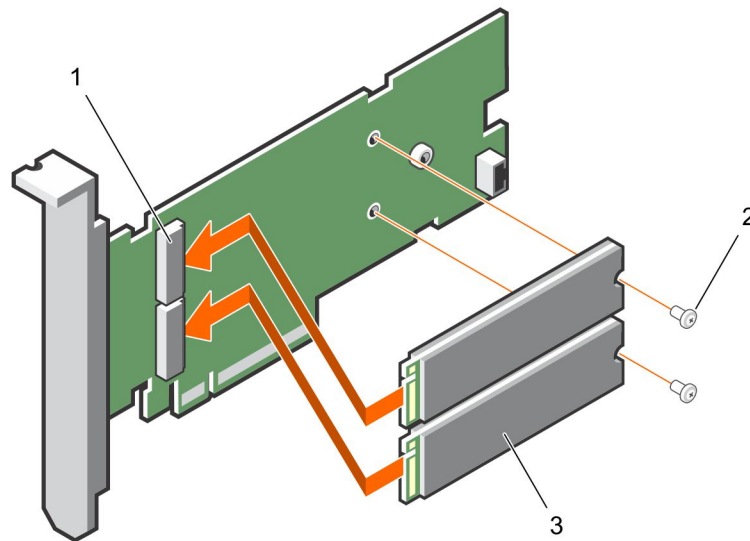

Figure 7. Installing M.2 SSD module on the BOSS-S1 card

- a. module connector (2)
- b. screw (2)
- c. M.2 SSD module (2)

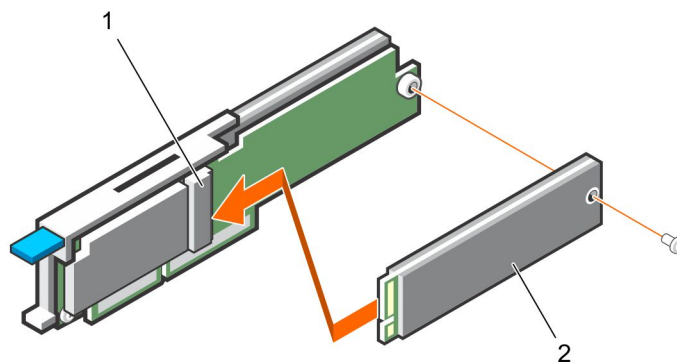

Figure 8. Installing the M.2 SSD module on the BOSS-S1 modular card

- a. module connector
- b. M.2 SSD module

Installing the BOSS-S1 card

CAUTION: Many repairs may only be done by a certified service technician. You should only perform troubleshooting and simple repairs as authorized in your product documentation, or as directed by the online or telephone service and support team. Damage due to servicing that is not authorized by Dell is not covered by your warranty. Read and follow the safety instructions that are shipped with your product.

1. Turn off the system, including any attached peripherals, and disconnect the system from the electrical outlet and peripherals.

NOTE: It is recommended that you always use a static mat and static strap while working on components in the interior of the system.

2. Open the system.
3. Hold the card by its edges and align the card connector with the connector on the system board.
- ⚠ CAUTION: To prevent damage to the card, hold the card by its edges only.**
4. Press the card-edge down until the card is fully seated.
5. If you are installing a modular card, tighten the screw that secures the card to the system board.
6. Close the system.
7. Reconnect the system to its electrical outlet and turn the system on, including any attached peripherals.

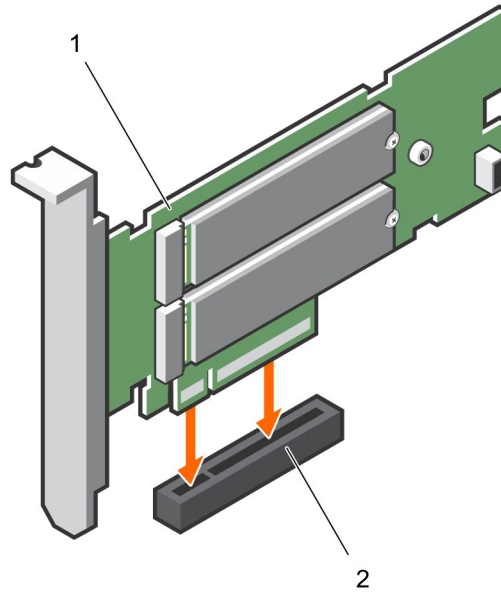

Figure 9. Installing the BOSS-S1 adapter card

- a. BOSS-S1 card
- b. card connector on the system board

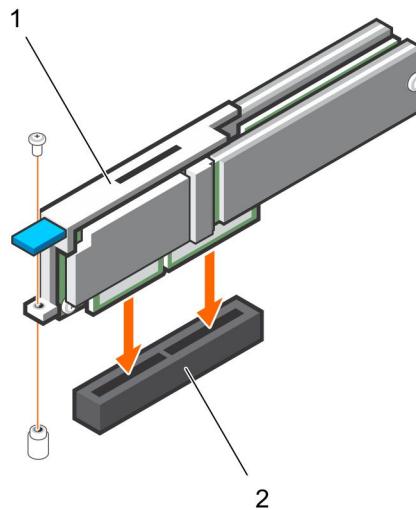

Figure 10. Installing the BOSS-S1 modular card

- a. modular card
- b. card connector on the system board

Driver installation

The BOSS-S1 card uses the native AHCI driver of the supported operating systems.

Windows driver installation — The Driver Update Package (DUP) updates drivers on the systems running Windows Server 2012 R2 and later operating systems. A DUP is an executable application that updates drivers for specific devices. A DUP supports command line interface and silent execution. For more information, see www.dell.com/support/home.

Linux driver installation — The Driver Update Disk (DUD) images are created only for those operating system releases in which the native, or in-box driver is insufficient for installation.

ESXi driver installation — By default, native AHCI driver is the in-box for installation.

UEFI or HII RAID configuration utility

The Unified Extensible Firmware Interface (UEFI) RAID configuration utility is a storage management application integrated into the system BIOS <F2>. It is used to configure and manage RAID disk groups, virtual disks, and physical disks. This utility is independent of the operating system.

The following topics provide information about using the UEFI RAID configuration utility. For more information, see the online help option in the UEFI RAID configuration utility.

NOTE: Use the UEFI RAID configuration utility for initial setup and disaster recovery. Certain advanced features are also offered in the utility.

Topics:

- [Entering the UEFI configuration utility](#)
- [Exiting the UEFI configuration utility](#)
- [Entering the BOSS-S1 configuration utility](#)
- [Physical or virtual disk information](#)
- [Creating a virtual disk](#)
- [Deleting virtual disks](#)
- [RAID rebuild](#)
- [Erase physical disk](#)
- [Controller information](#)

Entering the UEFI configuration utility

Perform the following steps to boot to the UEFI configuration utility:

1. Turn on the system.
2. While the system is booting, press <F2> to enter **System Setup**.
3. Click **Device Settings**.
Device Settings lists all the RAID controllers in the system.

To access the management menu for the controller, use the arrow keys or the mouse.

NOTE: For more information in all the options, click **Help**, available on the top right-hand corner of the browser screen. **Help** information for individual option menus can also be viewed by scrolling down on each option.

NOTE: Some of the options within the UEFI RAID configuration utility are not present if the controller does not support the corresponding feature. Options may also be disabled if the feature is not supported in the existing configuration.

Exiting the UEFI configuration utility

To exit the UEFI configuration utility, perform the following steps:

1. Click **Finish** at the bottom-right corner on the **System Setup Main Menu** screen.
A warning message confirming your choice appears.
2. Click **Yes** to exit the configuration utility.

NOTE: Depending on the device configuration changes, exiting the UEFI configuration utility may prompt for a system reboot.

Entering the BOSS-S1 configuration utility

1. Enter the UEFI configuration utility. See [Entering the UEFI RAID configuration utility](#)

The **Device Settings** screen displays a list of NIC ports and the BOSS-S1 configuration utility.

- To enter BOSS-S1 configuration utility, click **BOSS-S1 Configuration Utility**.
The list of **Configuration Options** appears:
 - **Physical/Virtual Disk Information** — view the properties of physical disks and virtual disks
 - **Create RAID Configuration** — configure a virtual disk
 - **Delete RAID Configuration** — delete a virtual disk
 - **RAID Rebuild** — rebuild a degraded RAID volume, if a suitable peer drive is available
 - **Erase Physical Disk** — clear data on a physical disk
 - **Controller Information** — view BOSS-S1 adapter information

Physical or virtual disk information

The **Physical/virtual disk information** menu allows you to view physical disk properties and virtual disk properties.

Physical disk information

To view physical disk information:

- Enter the **BOSS-S1 Configuration utility**. See [Entering the BOSS-S1 Configuration Utility](#).
- Click **Physical/Virtual disk information**.
All available physical disks are displayed.
- Select a physical disk to view its information.

Virtual disk information

To view virtual disk information:

- Enter the **BOSS-S1 Configuration utility**. See [Entering the BOSS-S1 Configuration Utility](#).
- Click **Physical/Virtual disk information**.
- Select **Virtual disk info**.
All available virtual disks are displayed.
- Select a virtual disk to view its information.
- Observe quick initialization information in the virtual disk information.

Virtual disk import

The Import operation sets a foreign virtual disk as native to the configuration.

- Enter the **BOSS-S1 Configuration utility**. See [Entering to BOSS-S1 Configuration Utility](#).
- Click **Physical/Virtual disk information**.
- Click **Virtual disk information**.
- Select the virtual disk.
- Select **Yes** for the option **Would you like to import this virtual disk?**.
 **NOTE:** This option is only available when the controller detects a foreign disk.
- Click **OK**, and then click **Import**.
- Click **Back** until you return to the screen.
- Click **Finish**, and then click **Yes** to save the settings.

Creating a virtual disk

- Enter the **BOSS-S1 Configuration Utility**. See [Entering the BOSS-S1 Configuration Utility](#).
- Click **Create RAID Configuration**.
- Select the physical disks.
- Click **Next**.

5. Type a name for the virtual disk in the **Name** field.
i **NOTE: Adding special characters in the virtual disk name is not supported.**
6. Select **Yes** for the option **Would you like to create this virtual disk?** and click **OK**.
7. Click **Next**, and then click **OK**.
A virtual disk is created with quick initialization by default.

Deleting virtual disks

1. Enter the **BOSS-S1 configuration utility**. See [Entering the BOSS-S1 Configuration Utility](#).
2. Click **Delete RAID configuration**.
3. Select the virtual disk.
4. Select **Yes** for the option **Are you sure you want to delete the selected Virtual Disk?**
5. Click **OK**, and then click **Next** to delete the selected virtual disk.

RAID rebuild

You can manually rebuild a degraded virtual disk. RAID rebuild is available only when a degraded RAID volume is present and there is an available target device. If a foreign virtual disk is in rebuild state, rebuild starts automatically after you import the virtual disk and reboot the server. Clear configuration operation does not affect any background activity, like rebuild.

Erase physical disk

i **NOTE: Erase physical disk is not supported when the physical disk is a part of virtual disk.**

1. Enter the **BOSS-S1 Configuration Utility**. See [Entering the BOSS-S1 Configuration Utility](#).
2. Click **Erase Physical Disk**.
3. Select the devices by selecting the check box next to the available physical disk configuration.
4. Select **Yes** for the option **Would you like to erase this Physical Disk?**
5. Click **Next**.
After the physical disk is successfully erased, the **Physical Disk** Information tab shows the physical disk status as **unconfigured**.

Controller information

The Controller information menu allows you to view the properties of the RAID Controller.

1. Enter the **BOSS-S1 configuration utility**. See [Entering the BOSS-S1 Configuration Utility](#).
2. Click **Controller information**.
The RAID adapter information is displayed.

Clear controller configuration

The clear config operation is used to clear RAID metadata from the adapter.

i **NOTE: The clear config operation does not delete any data on the virtual disk.**

1. Click **Controller information**.
2. Select **Clear Config**.
3. Click **OK**.

BOSS-S1 CLI commands

This section provides information about the methods to use the BOSS-S1 command line interface (CLI) for performing a variety of controller and enclosure specific operations.

The BOSS-S1 CLI utility is supported on the following operating systems:

- Windows
- Linux
- ESXi

Topics:

- [Using CLI commands from Windows](#)
- [Using CLI commands from Linux](#)
- [Using CLI commands from ESXi](#)
- [Supported BOSS-S1 CLI commands](#)

Using CLI commands from Windows

Follow these procedures to run the command line interface (CLI) commands using the Windows operating system:

1. Download the latest **MVSETUP BOSS-S1 utility for Windows** from www.dell.com/support/home.
2. Extract the content of the **mvsetup_xxxx_Axx.zip** file on the system.
3. Navigate to the directory where you have extracted the content of the **mvsetup_xxxx_Axx.zip** file and run the **mvsetup.exe** file. The CLI window, within which you can run BOSS-S1 CLI commands, is displayed. where you can run the BOSS-S1 CLI commands.

Using CLI commands from Linux

Follow these procedures to run the Command Line Interface (CLI) commands using the Linux operating system:

1. Download the latest **MVCLI BOSS-S1 utility for Linux** from www.dell.com/support/home.
2. Extract the content of the **mvcli.xxxx_Axx.zip** file on the system.
3. Navigate to the directory to which you have extracted the content of the **mvcli.xxxx_Axx.zip** file and run the **./install** and **./mvcli** files. The CLI window, within which you can run BOSS-S1 CLI commands, appears.

Using CLI commands from ESXi

Follow these procedures to run the command line interface (CLI) commands using the ESXi operating system:

1. Install ESXi on a host machine.
2. Use **WinSCP** or **SCP** and copy the attached files into the **/tmp/ directory**.
3. Log in to an **ESXi shell** using putty.
4. Change the directory to **cd /tmp**.
5. Run the command, `- esxcli software vib install -d /tmp/SAS-RAID_BOSS-S1_CLI_Axx.zip` to install the offline bundle. Successful commands are reported at the command line.
6. Enter the directory **cd /opt/Marvell** and run the command at the CLI normally.

 **NOTE: ESXi 6.5 U1 or ESXi 6.0 U3 P06 is the minimum requirement to install the BOSS-S1 CLI utility.**

Supported BOSS-S1 CLI commands

The following table lists the supported BOSS-S1 command line interface (CLI) commands. For more information about the commands, type `> help`.

NOTE: The BOSS-S1 CLI utility only supports the following commands:

Table 5. Supported CLI commands

CLI commands	Description	Windows Usage	Linux / VMware Usage
<code>info -o hba</code>	Display BOSS-S1 controller information.	<code>mvsetup info -o hba</code>	<code>./mvcli info -o hba</code>
<code>info -o vd</code>	Display virtual drive information.	<code>mvsetup info -o vd</code>	<code>./mvcli info -o vd</code>
<code>info -o pd</code>	Display physical drive information.	<code>mvsetup info -o pd</code>	<code>./mvcli info -o pd</code>
<code>smart -p <PD_ID></code>	Display SMART information of physical drive.	<code>mvsetup smart -p 0</code>	<code>./mvcli smart -p 0</code>
<p>NOTE: SMART reports the health status of the M.2 disks. Refer to the SMART status return once the command is executed.</p>			
<code>event</code>	Display controller events.	<code>mvsetup event</code>	<code>./mvcli event</code>
<p>NOTE: There may be inconsistency in the events that are listed in BOSS CLI and other management interfaces that include Dell EMC Open Manage Storage Services.</p>			
<code>flash</code>	Enables you to perform controller firmware upgrade.	<code>mvsetup flash -a update -f <image binary file> -t raw</code>	<code>./mvcli flash -a update -f <image binary file> -t raw</code>
<code>help</code>	Details help for all commands or for only one command.	<code>mvsetup help info</code>	<code>./mvcli help info</code>

Troubleshooting

To get help with your Dell BOSS-S1 card, you can contact your Dell Technical Service representative or see Dell.com/support.

Topics:

- ROM version for BOSS reported as firmware version in iDRAC interface
- Firmware update of M.2 drive on BOSS-S1 controller fails
- BOSS-S1 CLI displays No Adapter Found error in Linux
- LC log displays fan unavailability error
- Updating BOSS-S1 controller firmware using iDRAC or LC fails
- Physical disk size not updated in iDRAC
- Physical disk/Virtual disk missing in iDRAC
- Back Ground Activity task progress in HII does not report real-time status
- Virtual disk state will be generated twice
- Character limitation while naming a virtual disk
- VMFS datastore is disabled on the 14th generation of PowerEdge systems that are shipped with VMware ESXi installed on BOSS-S1
- Physical disk not visible to operating system
- Virtual disk not visible to operating system
- Drive replacement
- Controller replacement
- Controller failure
- Unable to boot to M.2 drive installed in slot 1
- CLI reports unsupported features
- Failure to install ESXi on RAID 1
- System not responding
- Management port not responding

ROM version for BOSS reported as firmware version in iDRAC interface

Issue: Starting with BOSS-S1 A01 release, BOSS-S1 versions are tracked using the ROM version. Therefore, iDRAC may report the ROM version as firmware version. For example, 2.5.13.2008 for A01, 2.5.13.2009 for A02, or 2.5.13.3011 for A03.

Corrective Action: This is an expected behavior and no action is required.

Firmware update of M.2 drive on BOSS-S1 controller fails

Issue: Firmware update of M.2 drives using the iDRAC web interface fails when the drive is in foreign state.

Corrective Action: Import the foreign configuration before updating the firmware of the drives.

BOSS-S1 CLI displays No Adapter Found error in Linux

Issue: BOSS-S1 CLI displays No Adapter Found error message in the Linux operating system.

Probable Cause: Using the BOSS-S1 CLI, when you run the CLI commands using non-administrative user privileges, the error No Adapter found is displayed.

Corrective Action: Use root/sudo administrator privilege while you run the CLI commands.

LC log displays fan unavailability error

Issue: LC log displays The BOSS-S1 device does not have a fan installed in it error message.

Probable Cause: Currently there is no fan requirement for BOSS-S1, which might be required in future based on M.2 thermal requirement.

Corrective Action: No action required. This error message can be ignored.

Updating BOSS-S1 controller firmware using iDRAC or LC fails

Issue: Updating firmware on a BOSS-S1 controller from versions A00 to A01 using iDRAC/LC fails.

Probable Cause: The systems management support is not enabled in the firmware version A00. iDRAC/LC update is supported only on the firmware version A01 and later.

Corrective Action: Use UEFI, OS DUP, or BOSS -S1 CLI to update firmware.

Physical disk size not updated in iDRAC

Probable Cause: When Collect System Inventory on Reboot (CSIOR) is disabled, iDRAC displays partial information about BOSS-S1 components.

Corrective Action: Ensure that CSIOR is enabled in iDRAC for the server to collect the system inventory on reboot.

 **NOTE: Ensure that the BOSS-S1 controller firmware and iDRAC firmware are updated to the latest version.**

Physical disk/Virtual disk missing in iDRAC

Probable Cause: When Collect System Inventory on Reboot (CSIOR) is disabled, iDRAC displays partial information about BOSS-S1 components.

Corrective Action: Ensure that CSIOR is enabled in iDRAC for the server to collect the system inventory on reboot.

 **NOTE: Ensure that the BOSS-S1 controller firmware and iDRAC firmware are updated to the latest version.**

Back Ground Activity task progress in HII does not report real-time status

Issue: Back Ground Activity (BGA) task progress in HII does not report the real-time status of running tasks.

Probable Cause: This is an expected firmware behavior, and there is no functionality loss.

Corrective Action: It is recommended that you check the BOSS-S1 CLI for status.

 **NOTE: BOSS-S1 Command Line Interface (CLI) and Dell EMC Open Manage Storage Services only report events for the tasks that are completed.**

Virtual disk state will be generated twice

- Issue:** Events related to virtual disk state will be generated twice in BOSS-S1 CLI and Open Manage Storage Services (OMSS).
- Probable Cause:** This occurs when Dell EMC PowerEdge Servers perform a cold reboot.
- Corrective Action:** These events can be safely ignored as there is no functionality loss.

Character limitation while naming a virtual disk

- Issue:** Limitation in the number of characters while creating a virtual disk name
- Corrective Action:** It is recommended that you use maximum of 10 characters while naming the virtual disk.

VMFS datastore is disabled on the 14th generation of PowerEdge systems that are shipped with VMware ESXi installed on BOSS-S1

- Issue:** Installation of ESXi on a BOSS-S1 device does not have VMFS datastore enabled by default, and disables VMFS if you use a custom image for installation. This issue occurs when using ESXi version 6.5.x or later on the BOSS-S1 card.
- Corrective Action:** When you have VMware ESXi installed on BOSS-S1, it is recommended that you use the BOSS-S1 device only as a boot device and disable VMFS if you are installing a custom image. For more information, see <https://kb.vmware.com/s/article/2004582> and <https://kb.vmware.com/s/article/2145210>.
- NOTE:** The scratch partition is created and configured during VMware ESXi installation in addition to boot support on BOSS-S1.

Physical disk not visible to operating system

- Issue:** One or both physical disks are not appearing for use by an operating system.
- Probable Cause:** A physical disk will not be presented to the operating system in the following scenarios:
- There is RAID metadata on the physical disk and no RAID metadata on the controller.
 - The BOSS-S1 controller has RAID metadata on it and the physical disk does not have the RAID metadata on it.
- Corrective Action:** If the RAID metadata is on the controller, follow the steps listed in [Clear Controller Configuration](#).
If the RAID metadata is on the physical disk, follow the steps specified in [Erase physical disk](#).
Alternatively, if you want to keep the RAID drive, refer to [Virtual Disk Not visible to Operating System](#)

Virtual disk not visible to operating system

- Issue:** In RAID mode a virtual disk is not appearing for use by an operating system.
- Probable Cause:** Virtual disks will not be presented to the system if they are not native to the controller.
- Corrective Action:** Import the virtual disk via HII as specified in section [Virtual Disk Import](#).

Drive replacement

- Issue:** An installed drive is not listed in the BOSS-S1 configuration utility.

OpenManage reports **Physical disk offline** state.

Probable Cause: Drive is either in failure state or has corrupted firmware.

Corrective Action: Reseat drive to ensure drive is inserted correctly. If error persists, attempt to update drive firmware using DUP. If error is still present, replace erroneous drive.

Controller replacement

Issue: Controller's UEFI configuration utility menu entry not appearing.

Probable Cause: This is either a firmware or a hardware fault.

Corrective Action:

- Flash the latest firmware on the BOSS adapter.
- If the problem persists, shutdown the server and unplug the BOSS-S1 adapter.
- Plug the BOSS-S1 adapter into the PCIe slot.
- Boot the system and check the UEFI configuration utility menu again.

If the issue persists, see [Controller Failure](#).

 **NOTE:** Ensure that the system is completely disconnected from all power sources before making any hardware changes.

Controller failure

Issue: BOSS-S1 device is not presented to system.

Probable Cause: Hardware fault on the card.

Corrective Action: Replace the BOSS-S1 adapter.

Unable to boot to M.2 drive installed in slot 1

Issue: When two unconfigured bootable M.2 drives are inserted into the BOSS-S1 device, only the slot 0 drive may be used as a boot drive.

Probable Cause: Working as designed, BIOS only allows booting from the first listed boot device, in this case, slot 0 per peripheral controller. This only occurs in legacy BIOS boot mode.

Corrective Action: Remove the drive from slot 1 and install it in slot 0.

CLI reports unsupported features

Issue: Several commands, options, or other features listed by the CLI state that they are unsupported when run.

Probable Cause: CLI shows the same information on all Marvell products, but only implements the functions which are pertinent to that platform or system.

Corrective Action: Use supported features.

Failure to install ESXi on RAID 1

Issue: Attempting to install ESXi on a RAID 1 results in an invalid partition table error.

Probable Cause: If an unconfigured physical disk containing an ESXi partition is used in a virtual disk, any attempts to install a partition of ESXi on this virtual disk will raise an error due to failure to clear out the previous partition.

Corrective Action: Delete the existing RAID 1, run `erase physical disk` on both drives, re-create the RAID 1 with quick initialization ON, then attempt to reinstall ESXi on the virtual disk.

System not responding

Issue Systems with ESXi OS stops responding.

Corrective Action: Ensure that the latest version of ESXi OS is installed.

Management port not responding

Issue BOSS-S1 management port not responding in ESXi.

Corrective Action: Ensure that the latest version of ESXi OS is installed.

Getting help

Contacting Dell EMC

Dell EMC provides several online and telephone based support and service options. If you do not have an active internet connection, you can find contact information about your purchase invoice, packing slip, bill, or Dell EMC product catalog. Availability varies by country and product, and some services may not be available in your area. To contact Dell EMC for sales, technical assistance, or customer service issues:

1. Go to www.dell.com/support/home.
2. Select your country from the drop-down menu on the lower right corner of the page.
3. For customized support:
 - a) Enter your system Service Tag in the **Enter your Service Tag** field.
 - b) Click **Submit**.
The support page that lists the various support categories is displayed.
4. For general support:
 - a) Select your product category.
 - b) Select your product segment.
 - c) Select your product.
The support page that lists the various support categories is displayed.
5. For contact details of Dell EMC Global Technical Support:
 - a) Click [Global Technical Support](#).
 - b) The **Contact Technical Support** page is displayed with details to call, chat, or e-mail the Dell EMC Global Technical Support team.

Documentation feedback

Click the **Feedback** link in any of the Dell EMC documentation pages, fill out the form, and click **Submit** to send your feedback.