



Dell EqualLogic PS6610 Storage Arrays

Hardware Owner's Manual

Version 1.0

Regulatory Model Series E11J

© Copyright 2016 Dell Inc. All rights reserved.

Dell™ and EqualLogic® are trademarks of Dell Inc.

All trademarks and registered trademarks mentioned herein are the property of their respective owners.

Information in this document is subject to change without notice.

Reproduction of this material in any manner whatsoever without the written permission of Dell is strictly forbidden.

Published: April 2016

Part Number: 110-6205-EN-R3

Table of Contents

Preface	v
1 Basic Storage Array Information	1
About the PS6610 Array	1
PS6610 Features	1
Recommended Tools	6
Hardware Protection	6
Shutting Down and Restarting an Array	6
2 Drive Maintenance	9
Supported Drives and Drive Types	9
Drive Installation Guidelines and Restrictions	9
Drive Handling Requirements	9
Drive Maintenance Requirements	10
Array Behavior When a Drive Fails	11
Identifying Failed Drives	11
Interpreting Drive LEDs	11
3 Control Module Maintenance	15
Control Module Features	15
Replace a Control Module	21
Replace the MicroSD Card	25
Battery Replacement	27
Shipping Requirements	28
4 Maintain Power Supply Units	31
About Power Supplies	31
Identifying Power Supply Failures	31
5 Maintain Fan Modules	35
6 Advanced Networking Options	37
7 Troubleshooting Your Array	39
Safety First—For You and Your Array	39
Determining Service Tag Information	39
Obtaining Component Diagnostics	39
Array Startup Failure	39
Loss of Array Connections	40
Loss of External Connections	40
Power Supply Failure	40
Array Cooling Problems	40
Control Module Failures	41
Faulty Hard Drives	41
Index	43

Preface

This manual describes how to install Dell™ EqualLogic® PS6610 storage array hardware, configure the software, and start using the iSCSI SAN array.

With one or more PS Series storage arrays, you can create a PS Series group—a self-managing, iSCSI storage area network (SAN) that is affordable and easy to use, regardless of scale.

Audience

The information in this guide is intended for the administrators responsible for installing array hardware. Administrators are not required to have extensive network or storage system experience. However, it is helpful to understand:

- Basic networking concepts
- Current network environment
- User disk storage requirements
- RAID configurations
- Disk storage management

Note: Although this manual provides examples of using PS Series arrays in some common network configurations, detailed information about setting up a network is beyond its scope.

Related Documentation

For detailed information about FS Series appliances, PS Series arrays, groups, volumes, array software, and host software, log in to the Documentation page at the customer support site (eqsupport.dell.com).

Dell EqualLogic Storage Solutions

To learn more about Dell EqualLogic products and new releases, visit the Dell EqualLogic Tech Center site: delltechcenter.com/page/EqualLogic. Here you can also see articles, demos, online discussions, and more details about the benefits of our product family.

Obtaining Technical Support and Customer Service

Dell's support service is available to answer your questions about PS Series arrays. If you have an Express Service Code, have it ready when you call. The code helps Dell's automated-support telephone system direct your call more efficiently.

Contacting Dell

Dell provides several online and telephone-based support and service options. Availability varies by country and product, and some services might not be available in your area.

To contact Dell EqualLogic Technical Support by phone, if you are located in the United States, call 800-945-3355. For a listing of International Dell EqualLogic support numbers, visit dell.com/support/home. From this web site, you can select a different country at the bottom of the screen. If you do not have access to an Internet connection, contact information is printed on your invoice, packing slip, bill, or Dell product catalog.

Use the following procedure to register for an EqualLogic customer support account, to log cases via the web, and to obtain software updates, further documentation, and resources.

1. Visit eqlsupport.dell.com or the Dell support URL specified in information provided with the Dell product.
2. Select the required service. Click the `Contact Us` link, or select the Dell support service from the list of services provided.
3. Choose your preferred method of contacting Dell support, such as email or telephone.

Online Services

You can learn about Dell products and services by visiting dell.com (or the URL specified in any Dell product information).

Warranty Information

The array warranty is included in the shipping box. For information about registering a warranty, visit onlineregister.com/dell.

Further Information

For initial setup information, refer to the *Installation and Setup Guide* for your PS Series array.

Notes, Cautions, and Warnings

- A NOTE symbol indicates important information that helps you make better use of your hardware or software.
- A CAUTION symbol indicates potential damage to hardware or loss of data if instructions are not followed.
- A WARNING symbol indicates a potential for property damage, personal injury, or death.



Heavy weight warning. A fully configured PS6610 enclosure weighs up to 131 kg (288 lb). An unpopulated enclosure weighs 64 kg (141 lb). Use appropriate lifting methods.



High temperature warning. The operating temperature inside the enclosure can reach up to 60°C (140° F). Take care when opening drawers and removing carriers.



Electrical disconnection warning. Indicates that all electrical supply connections to the enclosure should be disconnected before proceeding.

1 Basic Storage Array Information

This chapter includes information about the location and basic operation of the replaceable components in a storage array, tools and equipment you will need, protecting hardware from electrostatic discharge, and power on and off operations.

About the PS6610 Array

The PS6610 array is a PS6x10 10GbE class EqualLogic PS Series array that continues the focus by Dell on industry-standard features and capabilities for the midrange iSCSI SAN market. PS Series Storage Arrays version 8.0 introduces the PS6610.

PS6610 Features

The PS6610 array is a 5U chassis that can be configured with either 42 or 84 drives. Both 2.5-inch and 3.5-inch drives are supported in either configuration. Features of the PS6610 include:

- Two hot-swappable Type 18 control modules, which contain increased memory (16GB per controller) and a more powerful processor than previous generation controllers.
- 5U SAS Drive Enclosure
- Ethernet ports:
 - Two pairs of 10Gb/s dual-media interfaces (10GBASE-T/SFP+)
 - Ability to fall back to 1 GB/s interface (10GBASE-T ports only)
- Support for ReadyRails™ II

Front-Panel Features and Indicators

The main features of the front panel are shown in [Figure 1](#) and identified in [Table 1](#). The left and right sides of each drawer on the PS6610 each contain an anti-tamper lock (see [Figure 2](#)), a recessed handle for opening the drawer, and a sideplane status indicator (see [Figure 3](#)) that monitors the operation and activity of each sideplane. As you face the front of the chassis, an Enclosure Status Indicator is located on the left edge that provides status information for the entire array (see [Figure 4](#)).

- [Table 2](#) describes the sideplane status indicators located on the drawers.
- [Table 3](#) describes the enclosure indicator.

Figure 1: Front Panel Features

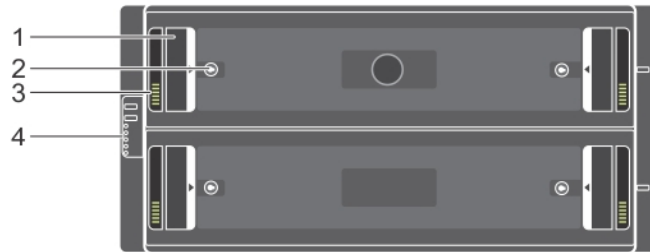
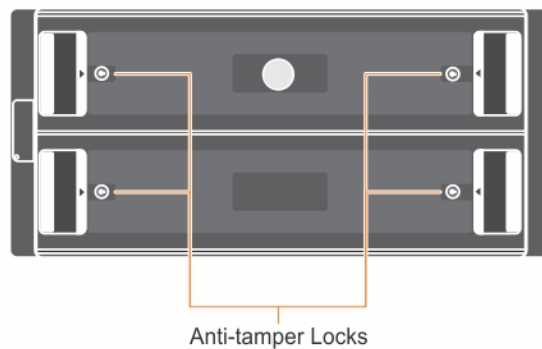

Table 1: Front Panel Feature Identification

Item	Description
1	Recessed Handle
2	Anti-Tamper Lock
3	Sideplane Status Indicator
4	Enclosure Status Indicator

Figure 2: Anti-Tamper Locks



Note: The anti-tamper locks require a T20 Torx key (included). To lock drawers, turn the key until the red arrows point away from the center of the enclosure.

Figure 3: Sideplane Status Indicator

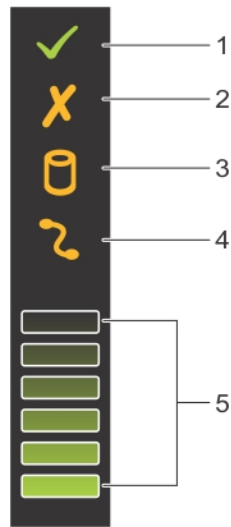

Table 2: Sideplane Status Indicator Description

Item	Indicator	Description
1	Sideplane OK/ Power Good	Off — Sideplane card or cable fault Green — Sideplane card and cable are functional (though a fault might be indicated by the following LEDs)
2	Drawer Fault	Amber — Sideplane card fault causing loss of availability or redundancy
3	Logical Fault	Amber (steady) — Host indicated drive fault
4	Cable Fault	Amber — Cable fault
5	Activity Bar Graph	Represents the relative amount of drive activity in that sideplane

Figure 4: Enclosure Status Indicator

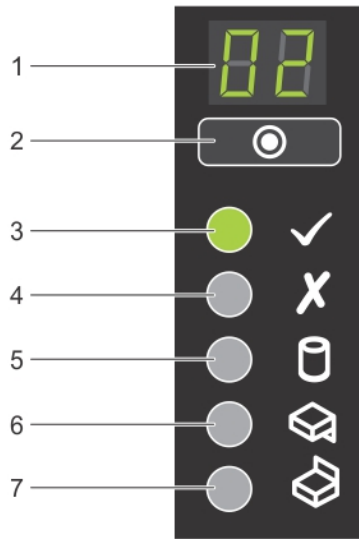

Table 3: Enclosure Status Indicator Description

Item	Indicator	Description
1	Enclosure Status Indicator	Unit ID Display — A numerical display whose primary function is to display the enclosure unit identification number. This display can be helpful when setting up and maintaining a multiple-enclosure storage center.
2	Input Switch	Used to set the Unit ID Display
3	Power On/Standby	Off — The enclosure does not have power Green — The enclosure is on (operational) Amber — The enclosure is in standby mode (not operational)
4	Module Fault	Indicates the current health condition of the array: <ul style="list-style-type: none"> Off — No faults Amber (blinking) — Warning condition Amber (steady) — Critical condition that might be set by either a hardware fault or a RAID double-fault condition or similar error. Additionally, an LED might be lit on a PSU, drawer, DDIC, fan module, or IO module indicating the part at fault.
5	Logical Status	Indicates a drive fault. The LED lights up amber when there is a drive fault of some kind. A fault LED will also be lit on the offending drive(s) in the system, and the sideplane status indicator will show a logical fault.
6	Drawer 1	Amber when a drive, cable, or sideplane fault has occurred in

Item	Indicator	Description
	Fault	drawer 1
7	Drawer 2 Fault	Amber when a drive, cable, or sideplane fault has occurred in drawer 2

Note: The LEDs are part of a built-in chassis control panel that is not hot-swappable and can be replaced only by support personnel. During the array power-up sequence, these LEDs will cycle through different states until the array is fully started and the active control module has been determined.

Back-Panel Features and Indicators

The back of a PS6610 is shown in [Figure 5](#).

[Table 4](#) describes the main features of the back panel.

Figure 5: Back-Panel Features

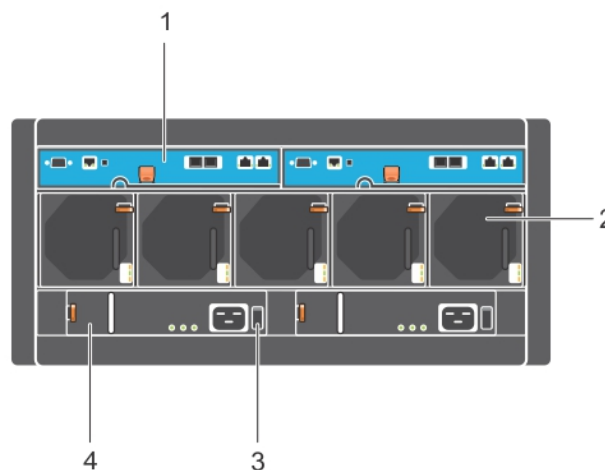

Table 4: Description of Back-Panel Features

Item	Feature	Identifier	Description
1	Control Module	CM0 (left) CM1 (right)	The control module provides: <ul style="list-style-type: none"> • Connection to a data path between the array and the applications using the storage • Array management functions for your array
2	Cooling Fan Modules	Modules are labeled 0-4 from left to right	Cooling fan module for array (5 total)
3	Power Switches	None	Controls power supply output to the array. Each

			power supply has one switch.
4	Power Supply Unit (PSU)	PSU0 (left) PSU1 (right)	Power supply module for array

Recommended Tools

- When performing any type of work on the PS6610 array, including inserting and removing disk drives, you should always wear a wrist grounding strap (not provided) to protect the hardware from electrostatic discharge. See [Hardware Protection](#).
- To lock and unlock the drawers on the array, you will need a T20 Torx key (provided).

Hardware Protection

When handling array hardware, use an electrostatic wrist strap (not included) or a similar form of protection to protect your PS Series array from electrostatic discharge. To use a wrist strap:

1. Connect the steel snap on the coil cord to the stud on the elastic band. See [Figure 6](#).

Figure 6: Using an Electrostatic Wrist Strap

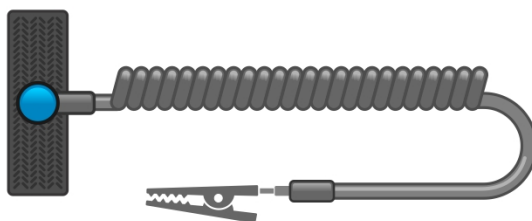

2. Fit the band tightly around your wrist.
3. Connect the band to ground. You can either plug the banana connector into a matching grounded receptacle, or attach it to the matching alligator clip and connect the clip to a grounded device. Examples of an appropriate ground would be an ESD mat or the metal frame of a grounded piece of equipment.

Shutting Down and Restarting an Array

The PS6610 array includes redundant, hot-swappable drives, power supplies, and control modules. You can remove a redundant component without affecting operation as long as a functioning component is available. Otherwise, Dell recommends that you cleanly shut down the array and turn off power before removing a component.

Note: When an array is shut down, any volumes with data on the array will be set offline until the array is successfully restarted. Being offline affects initiators that are connected to the volumes.

Array shutdown and restart procedure

1. Connect to the array in one of the following ways:

- Use telnet or SSH to connect to a functioning IP address assigned to a network interface on the array. Do not connect to the group IP address.
- Use the null modem cable, shipped with the array, to connect the serial port on the active control module (ACT LED is green) to a console or a computer running a terminal emulator.

Make sure the serial line characteristics are as follows:

- 9600 baud
 - One STOP bit
 - No parity
 - 8 data bits
 - No flow control
2. Log in to an account with read-write access, such as the `grpadmin` account.
 3. Enter the `shutdown` command:

```
login: grpadmin
Password:
Welcome to Group Manager
Copyright 2001-2014 Dell Inc.
group1> shutdown
```

After entering the `shutdown` command, the system displays information similar to the following output:

```
Do you really want to shutdown the system? (yes/no)
Halt at Fri Dec 12 09:43:44 EST 2014 -- please wait...
6932:0:logevent:12-Dec-2014 09:4-
3:44.400000:logevent.cc:238:WARNING::25.3.0: User has initiated a clean
halt restart.
```

```
Main power usage is 68.5702 watts
sbs_ship_mode: Ship Mode request sent to battery
```

```
PLEASE WAIT FOR SHIP MODE CONFIRMATION MESSAGE!!
```

```
Waiting for Ship Mode entry: 5 sec
Waiting for Ship Mode entry: 10 sec
Waiting for Ship Mode entry: 15 sec
Waiting for Ship Mode entry: 20 sec
Waiting for Ship Mode entry: 25 sec
Waiting for Ship Mode entry: 30 sec
Check peer controller completion
No peer responding, peer battery is off
Batteries are now in Ship Mode!
Placing array in standby mode. To exit standby mode press and hold a
standby switch on any controller in the array.
```

4. Switch off the enclosure power supplies.

Note: If you are using a network connection, the session will be disconnected before the array is fully shut down. Confirm that the ACT LED on each control module is off (not lit) before turning off power to the array at the power supply.

5. After performing array maintenance, you can turn on power to the array. When the array restart completes, the member and volumes will be set online.

2 Drive Maintenance

You can replace a failed drive while the array remains running.

Supported Drives and Drive Types

Depending on your configuration, your array supports either 42 or 84 of the 2.5-inch and 3.5-inch SAS and NL-SAS drives in internal drive bays. SSD drives are also supported in a hybrid configuration.

Drives are connected to the midplanes and backplane through drive carriers and are hot-swappable.

Drives are supplied in a carrier that is keyed to fit into a specific array model. The drives cannot be installed in other Dell arrays or in arrays not from Dell.

Note: Dell uses specially qualified and tested hard drives for its EqualLogic storage systems, and manages hard drive quality and firmware only for those drives. As a result, only Dell-provided hard drives are supported by PS Series arrays. Attempts to use unapproved hard drives in the PS6610 array will not be successful.

Mixed-Drive (Hybrid) Arrays

The PS6610ES supports a combination of fourteen (14) solid state drives (SSDs) and seventy (70) rotational drives (HDs) in the array. The proportion of SSDs to HDs cannot be changed. SSDs must all be installed in the same row in slots 0-13. See [Disk-Drive Slot Numbers on page 10](#).

Drive Installation Guidelines and Restrictions

It is extremely important to install the disk drives properly and maintain the performance of disk drives to ensure optimal operation of the array.

Only two drive configurations are supported: the half-populated array (42 drives) and the fully-populated array (84 drives).

Caution: In a half-populated array, the drives must be installed in specific rows across both drawers of the array. In a fully-populated hybrid array, the SSDs must be installed in a specific row. See the following list for more information.

The following restrictions apply when installing disk drives:

- When installing 42 drives, the array must have 2 complete rows of HDs in the top drawer (slots 0-27) and 1 complete row of HDs in the bottom drawer (slots 42-55). See [Disk-Drive Slot Numbers on page 10](#).
- When installing 84 drives, an optional hybrid configuration can be purchased that combines exactly 14 SSDs with 70 rotational drives (HDs). In hybrid arrays, the 14 SSDs must be inserted in the front row of the top drawer (slot locations 0-13). The proportion of SSDs to HDs cannot be changed. See [Disk-Drive Slot Numbers on page 10](#).
- Do not leave any drive slots empty in a populated row. Operating an array with an empty slot will void your warranty and support contract.

Drive Handling Requirements

When handling hard drives, take the following precautions:

- Protect drives from electrostatic discharge. Wear an electrostatic wrist strap when handling a drive. See [Hardware Protection on page 6](#).
- Store drives properly. Store replacement drives in the packaging in which they were shipped. Do not stack drives or place anything on top of a drive.
- Handle drives carefully. Hold a drive only by the plastic part of the carrier or the handle. Do not drop, jolt, or force a drive into a slot.
- Warm replacement drives to room temperature before installation. (Consider letting a new replacement drive sit overnight before installing it in an array.)
- Do not remove a drive from its carrier. This action will void your warranty and support contract.
- Keep the shipping material. Return a failed drive to your array support provider in the packaging in which the replacement drive was shipped. Shipping drives in unauthorized packaging might void your warranty.

Drive Maintenance Requirements

Disk drives must be installed properly and in a specific configuration to allow for the necessary airflow and cooling throughout the chassis. Failure to do so will trigger a warning condition.

- Failed drives should be replaced as soon as possible. However, if a drive fails and a replacement is not readily available, leave the failed drive in the slot until it can be replaced.
- When installing drives in the array, apply firm downward pressure with both hands and slide the drive toward the rear of the drawer until it snaps into place and the locking latch is fully engaged. See [Install Disk Drives on page 12](#).
- When correctly installed in the drawer, all top-facing drive surfaces should form a flat and level surface. If a drive is protruding upward in any way, reinstall the drive.
- After installation, verify that the drive power LED is green or flashing green.

Disk-Drive Slot Numbers

Disk-drive slots in the top drawer are numbered as shown in [Table 5](#). The disk-drive slots in the bottom drawer are numbered as shown in [Table 6](#).

Table 5: Top-Drawer Drive Numbers

28	29	30	31	32	33	34	35	36	37	38	39	40	41
14	15	16	17	18	19	20	21	22	23	24	25	26	27
0	1	2	3	4	5	6	7	8	9	10	11	12	13
Drawer Front													

Table 6: Bottom-Drawer Drive Numbers

70	71	72	73	74	75	76	77	78	79	80	81	82	83
56	57	58	59	60	61	62	63	64	65	66	67	68	69
42	43	44	45	46	47	48	49	50	51	52	53	54	55
Drawer Front													

Array Behavior When a Drive Fails

The PS6610 firmware uses a copy-to-spare operation to replace failing drives. This operation can, in many cases, improve the performance of the drive replacement process by avoiding a full RAID rebuild, which provides better reliability.

Note: If a drive fails, replace it. Do not reinstall it in the array. If a replacement drive is not available, keep the failed drive in the array until it can be replaced.

If a Spare Drive Is Not Available

If a spare drive is not available, the RAID set will become degraded and performance might be impaired. However, a RAID 6 set can survive two simultaneous drive failures.

If a spare drive is not available and the failed drive is in a RAID set that is already degraded, data might be lost and must be recovered from a backup.

Identifying Failed Drives

A drive failure is indicated by:

- An LED located on the drive. See [Interpreting Drive LEDs on page 11](#).
- An LED on the Enclosure Status Indicator.
- A message in the event log or in the Group Manager Alarms panel.
- Indications in the Group Manager group member Disks tab or the CLI `member select show disks` command output.

Inside each drawer, a Drawer Slot Label located on top of the sideplanes shows the drive numbering within each row. See [Disk-Drive Slot Numbers on page 10](#).

Interpreting Drive LEDs

The drive LED is shown in [Figure 7](#). The drive LED states are described in [Table 7](#).

Figure 7: LEDs on Drive Enclosure

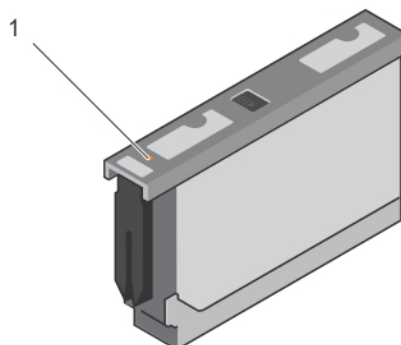

Table 7: Drive LED States

Item	Description	Indicator States
1	Drive status indicator (LED)	<ul style="list-style-type: none"> • Off — Drive OK • Amber — Drive failed • Blinking — Drive identification

Installing and Removing Disk Drives

The proper insertion and seating of hard drives in the chassis drawers is critical to the operation of the array. For proper cooling, do not remove a failed drive until it can be replaced with another.

Note: You should always wear electrostatic protection when handling a drive. See [Hardware Protection on page 6](#).

Install Disk Drives

The 3.5-inch drives and 2.5-inch drives come preconfigured in their carriers (DDICs) and are installed vertically into the top of the open drawer with the large arrow pointing toward the rear of the chassis.

Note: Installing a drive is easier if you work from the side of the open drawer.

1. Hold the drive by the carrier and slide the drive most of the way into a slot.
2. Using both hands (thumbs and forefingers), apply downward pressure firmly and equally across the carrier (see [Figure 8](#)).
3. While maintaining downward pressure, slide the drive carrier's top plate toward the back of the drawer until the release button in the center clicks into place (see [Figure 9](#)).

Note: It is possible for a drive to appear seated but not be fully locked into position, eventually causing it to dislodge itself. After installing a drive, check the release button in the center of the carrier. If the drive is *not* fully locked into position, a yellow line will be visible underneath the arrow button. If the yellow line is visible, remove the drive and reinstall it.

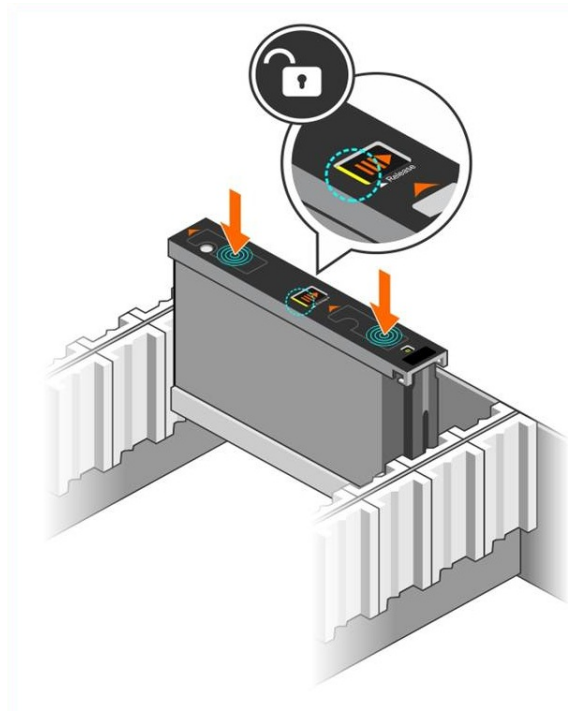
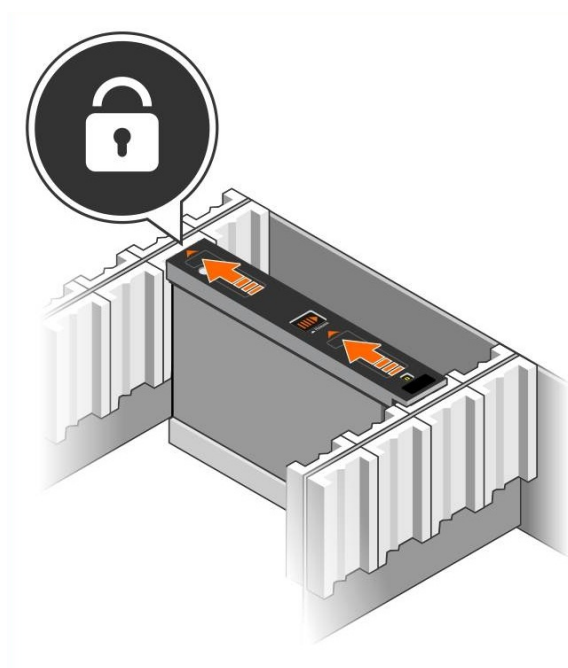
Figure 8: Inserting a Drive in the Drive Bay**Figure 9: Securing a Drive in the Drive Bay**

4. Verify that the new drive is operational by examining the LED on top of the DDIC. (An amber LED indicates that the drive is working properly.) In addition, you can examine the GUI group member Disks tab and the CLI `member select show disks` command output to check the status of all drives in the system.

Remove Disk Drives

Note: Removing a drive is easier if you work from the side of the open drawer.

1. Using two hands, apply firm downward pressure to the top surface of the drive carrier.
2. While maintaining downward pressure, use one finger to press the release button on the center of the carrier and push it in the direction of the arrow (callout 1 in [Figure 10](#)). The drive latch opens and the drive will emerge partway from the array.

Caution: When removing an active rotational drive, allow the drive to spin down for a few moments before removing it fully from the drive bay.

3. Pull the drive out by its carrier until it is free of the drive bay.

Figure 10: Removing a 3.5-Inch Drive

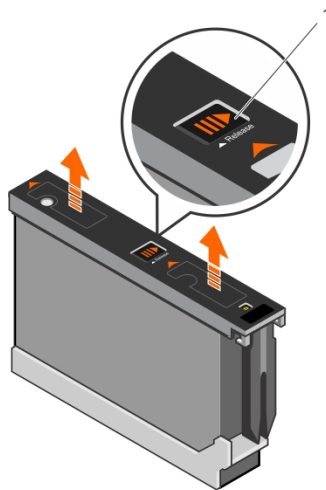

3 Control Module Maintenance

The control modules in a PS Series array contain the PS Series firmware, which provides the Group Manager GUI, the command-line interface (CLI), and all the array and storage management functions and features.

Ideally, an array has two control modules (which must be of the same type) to avoid a single point of failure for the array. The PS6610 array includes two hot-swappable Type 18 control modules.

One functioning control module is required for array operation. You access control modules from the rear of the array.

Control Module Features

The Type 18 control module includes:

- Two pairs of Ethernet ports with two shared LEDs indicating status and activity:
 - One pair of 10GBASE-T ports, labeled Ethernet 0 and Ethernet 1
 - One pair of SFP+ ports, labeled Ethernet 0 and Ethernet 1

Note: Only one of two ports with the same numbered port can be used at a time. If both ports are attached to an active switch, the control module will prefer to communicate over the SFP+ interface.

- One 10Mb/100Mbps port, labeled MANAGEMENT, for use only if you configure a management network. The management port has two LEDs to indicate status and activity. See [Configure the Management Port on page 37](#) for more information.
- A column of LEDs labeled PWR (power), ERR (error condition) and ACT (activity) that indicate the status of the control module.
- A recessed button labeled STANDBY ON/OFF that allows you to quickly shut down the array in certain circumstances. See [About the Standby On/Off Button on page 19](#) for more information.
- One serial port (for use if there is no network access to the array).
- A field-replaceable microSD card containing the PS Series firmware. The microSD card is accessed from the rear of the control module.
- A release button and latch to release the control module from the array for replacement. The release lever has a switch that detects activation and prompts the array to save data to non-volatile storage, thereby protecting your data.

Note: Do *not* mix control module types in an array. Always make sure both control modules are the same type and color. See the latest PS Series *Release Notes* for information about other supported control modules.

About Control Module Configurations

While an array can run using only one control module, it is not recommended because this configuration creates a single point of failure. If the control module fails and no other module can take over, all access to your volumes stops until the failure is repaired or the control module is replaced.

Only one control module is active (providing disk access and serving network traffic) at one time. The secondary (redundant) control module mirrors cache data from the active control module. If the active control module fails, all functions of the primary controller transfer to the secondary.

Dual Controller Configuration

A dual control module configuration eliminates a single point of failure in the array. If the active control module fails, the secondary control module takes over automatically with no interruption of service. This automatic transition gives you time to replace the failed control module while your volumes and data remain accessible.

In addition, a dual control module configuration supports a feature called vertical failover. An Ethernet port on the active control module can fail over to the same Ethernet port on the secondary control module if a network path fails.

Both Ethernet ports on the control module can fail over. [Figure 11](#) shows a recommended configuration for vertical failover.

Figure 11: Recommended Network Configuration to Support Vertical Failover

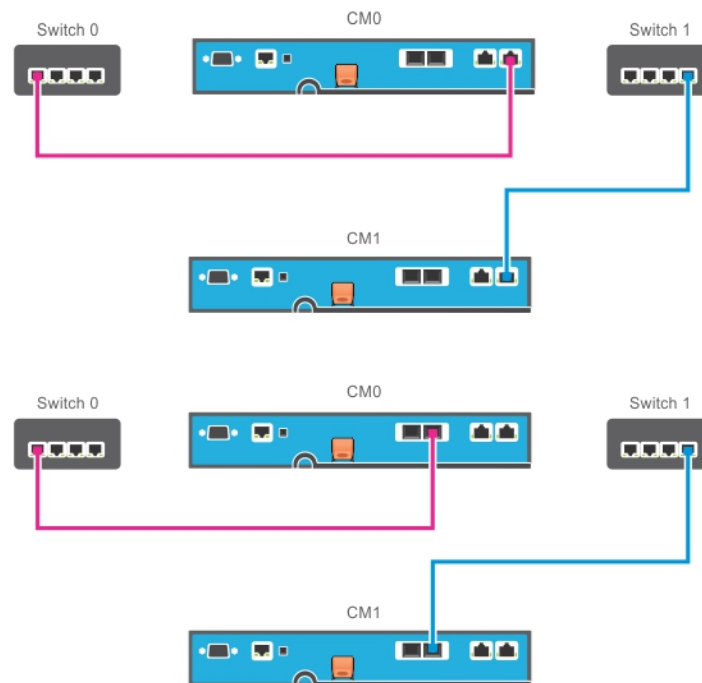

Note: If a network port is available for failover on either control module, but is not currently in use, its LEDs will not be lit.

Note: Vertical failover is transparent to applications.

Interpreting Control Module LEDs

Control modules have the following LEDs:

- The Ethernet ports and the management port each have LEDs that indicate the port's status and activity. See [Table 8](#).

- Above the release latch is a column of three LEDs that indicate the status of the entire control module. See [Table 9](#).

Figure 12: Control Module LEDs

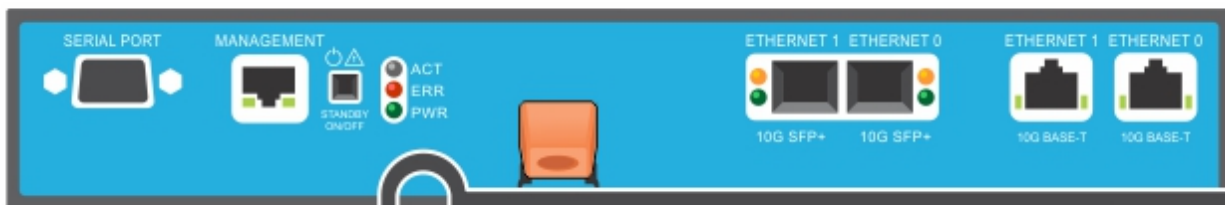

Table 8: Ethernet and Management Port LED Descriptions

Management LED Location	State	Description
Left (Link)	Off	No power or not connected to network
	On (green)	Connected to network (100Mbit)
	On (amber)	Connected to network (10Mbit)
SPF+ Ethernet LED Location	State	Description
Bottom (Link)	Off	No power, not connected to network, or passive
	On (green)	Connected to network
Top (Act)	Off	No power, not transmitting, or not receiving
	On (amber)	Transmitting or receiving
10GBASE-T Ethernet LED Location	State	Description
Right (Link)	Off	No power, not connected to network, or passive
	On (green)	Connected to network
Left (Act)	Off	No power, not transmitting, or not receiving
	On (amber)	Transmitting or receiving

Table 9: Control Module Status LED Descriptions

LED Name	State	Description
ACT	Off	No power, secondary control module is not synchronized with active control module, or error condition
	Steady green	Active control module (serving network I/O)
	Steady amber	Secondary control module. Cache is synchronized with active control module.

LED Name	State	Description
ERR	Off	Normal operation or no power
	Steady red	Array is starting up, in error condition, in Standby mode, or returning from Standby mode.
	Blinking red	Array is entering power standby mode because the Standby On/Off button was pressed.
PWR	Off	No power
	On (steady green)	Power/OK

Identify Control Module Failures

You can identify a failure in a control module by:

- LEDs on the control module itself. See [Interpreting Control Module LEDs on page 16](#).
- Messages on the console, in the event log, or in the Group Manager GUI Alarms panel.
- Group Manager GUI and CLI output. The Member Controllers window or the `member select show controllers` command output shows the control module status `not installed`.

When viewed from the rear of the array, CM0 is on the left and CM1 is on the right.

If a control module fails, contact your PS Series support provider for a replacement.

About Failover Behavior

In a dual control module array, only one control module is active (processing network I/O and performing storage functions) at one time. Each control module stores recently used data.

For redundancy, the cache on the secondary control module mirrors the data that is stored in the cache on the active control module.

The active control module can use the network interfaces of the secondary control module for failover if a cable is connected from the corresponding port on the secondary control module to a functioning network switch.

Note: The management ports on the control modules do not fail over if one control module fails. Therefore, if you are using a dedicated management network, make sure the management ports on both control modules are connected to the management network.

A PS Series array provides the following types of network failure protection:

- Vertical failover. In a dual control module array, a network port on the active control module can fail over to the same network port on the other (secondary) control module if a network path fails. For example, if Ethernet 0 on CM0 loses connectivity (switch 0 fails), Ethernet 0 on CM1 cache is enabled and utilized. See [Dual Controller Configuration on page 16](#) for details.
- Control module failover. In a dual control module array, if the active control module fails, the secondary control module automatically takes over and becomes active.

If a cable is connected to a network port on the newly active control module, network I/O can switch to its network interface. Depending on circumstances, network I/O might instead continue through the previously active control module. (For example, the control module that becomes active can use either its own local network interface, or the network interface on the previously active control module.)

Control module failover occurs automatically, and if iSCSI initiators reconnect to the group IP address, application I/O can continue without user intervention.

Control Module Firmware Maintenance

Each control module has a microSD card running the array firmware. You should run the latest firmware version to take advantage of new product features and enhancements.

Caution: In a dual control module array, both control modules must be running the same firmware version; otherwise, only one control module will be functional. You must update the controller with the older version firmware to the same version as the active controller before you update the member to a later version.

Group members should run the same firmware version; otherwise, only the functionality common to all versions will be available in the group. See the PS Series *Release Notes* for information about mixed-firmware groups.

If you are adding a second control module, upgrading a control module, or replacing a failed microSD card, contact your PS Series support provider, which is in most cases Dell EqualLogic Technical Support. Inform your provider of the current PS Series firmware version on your system. If you are replacing a failed control module, remove the microSD card from the failed control module and install it in the replacement control module. Installing the card ensures that you keep the correct firmware. See [Replace the MicroSD Card on page 25](#).

To display the firmware version running on an array, examine the GUI group member Controllers tab or use the following CLI command:

```
member select show controllers
```

If the firmware on a microSD card does not match the firmware running on an array, do not install it. Instead, contact your array support provider.

Control Module Handling Requirements

Follow these control module handling requirements:

- **Do not remove an active control module.**
- **Protect control modules from electrostatic discharge.** Always wear an electrostatic wrist strap when handling a control module. See [Hardware Protection on page 6](#).
- **Do not remove a control module from an array while the control modules are synchronizing.** When synchronization completes, a console message will appear. Also, the ACT LED on the secondary control module will be orange.
- **Do not leave a control module slot empty.** In an array with one control module, always attach a blank faceplate to the empty control module slot.
- **Store control modules properly.** Store a control module in its original packaging or in an antistatic bag or place the control module on a surface protected from electrostatic discharge.

About the Standby On/Off Button

The Type 18 control module has a small, recessed button labeled STANDBY ON/OFF located next to the management port (see [Figure 13](#)). The button is recessed to prevent accidental activation.

Figure 13: Standby Button Location

Enable the Standby Feature

To use the standby button, a group administrator must enable the feature in the Group Manager GUI or CLI.

Enabling the use of the button applies groupwide; that is, it allows you to press the button to shut down any member (array) that has the standby button (PS4100, PS4110, PS6100, PS6110, PS6210, and PS6610 array models). You do not need to enable use of the button on each member separately.

Note: Only a user with group administrator privileges can enable the standby feature on the group. However, anyone can press the button, and the group cannot determine who put the array into standby on/off mode. Therefore, group administrators should consider their environment's security concerns before enabling this feature.

Use the Standby On/Off Button

After the feature is enabled groupwide, you can use the Standby On/Off button on either control module of any applicable member to shut down the array quickly without using the Group Manager GUI or CLI.

- To shut down the member to the standby state, press in and hold the Standby On/Off button for at least two (2) seconds.
- To fully shut down the array, turn off the switches on the power supplies.
- To turn the member back on, press and hold the Standby On/Off button again (and ensure the power supply switches are turned back to the on position).

Important Considerations

Use the Standby On/Off button only when you must shut down a member quickly, in situations where you do not have access to the Group Manager GUI or CLI. For example, you discover a problem in your lab environment, such as high temperature or a water leak, that might damage the array.

Caution: In standby mode, all volumes that use space on that member or that are bound to that member become unavailable. All operations on the member are suspended, no I/O activity to or from the member occurs, and the member's firmware is not running.

Caution: When replacing a failed control module, do not shut down the array with the standby on/off button or by any other method. If the member is shut down, the array automatically returns to full-power mode when a control module is inserted.

Using the Standby On/Off button on one member does not affect any other group members, with the exception of the group lead member. When the group lead member is in standby mode, it takes a few minutes for the group lead to fail over to another member. You must press the standby button on each member to restore power to the member that is in standby mode. Group members that do not have the standby button remain online; to shut them down, you must use the GUI or CLI.

Replace a Control Module

If a control module fails, remove it and replace it with a functioning control module, as described in this section.

You will need to swap the battery from the old to the new control module before inserting the replacement control module.

You will also need to temporarily remove a control module when you want to replace its microSD card. Refer to [Replace the MicroSD Card on page 25](#) for information about replacing the microSD card.

You can partially or completely remove a control module without shutting down the array if the remaining control module has at least one connected and functioning network interface. The procedures for doing this type of control module replacement are described in [Control Module Replacement Procedures on page 21](#).

When you remove a control module, wear an electrostatic wrist strap, as described in [Hardware Protection on page 6](#), and be sure to place it on a surface that is protected from electrostatic discharge.

Control Module Replacement Procedures

This section describes the procedures for removing and replacing one or both control modules in your PS Series array. The following replacement scenarios are covered:

- Replacing the secondary control module in an array
- Replacing the active control module in an array
- Replacing both control modules in an array

Replacing the Secondary Control Module

If the array is fully powered up and functioning, use the following procedure to replace the secondary control module in the array:

1. Remove the control module from the array, as described in [Remove a Control Module on page 22](#).
2. Remove the SD card from the control module, as described in [Remove the MicroSD Card on page 25](#).
3. Install the SD card in the replacement control module, as described in [Insert the MicroSD Card on page 26](#).
4. Remove and swap the battery from the existing control module to the replacement control module, as described in [Battery Replacement on page 27](#).
5. Insert the replacement control module into the array, as described in [Install a Control Module on page 23](#).

Replacing the Active Control Module

Use the following procedure to replace the active control module in the array:

1. Shut down the system with a full shutdown, as described in *Shutting Down and Restarting an Array on page 6*.
2. Replace the control module, as described in *Replacing the Secondary Control Module on page 21*.
3. Remove and swap the battery from the existing control module to the replacement control module, as described in *Battery Replacement on page 27*.
4. Use the `restart` command to make the active control module secondary.
5. Install the SD card in the replacement control module.
6. Replace the control module that is now secondary (was active before the restart), as described in *Replacing the Secondary Control Module on page 21*.

Replacing Both Control Modules

Use the following procedure to replace both control modules in the array:

1. Replace the secondary control module first, as described in *Replacing the Secondary Control Module on page 21*.
2. Remove and swap the battery from the existing control module to the replacement control module, as described in *Battery Replacement on page 27*.
3. Use the `restart` command to make the active control module secondary.
4. Replace the control module that is now secondary (was active before the restart), as described in *Replacing the Secondary Control Module on page 21*.

Remove a Control Module

Before removing a control module:

- Review the information at the beginning of *Replace a Control Module on page 21*.
- Attach an electrostatic wrist strap. See *Hardware Protection on page 6*.
- Disconnect any serial or network cables attached to the control module. If the other control module has open interface connectors, reattach the network cables to the other control module to provide uninterrupted data access.

Caution: Do not remove an active control module.

To remove a control module:

1. Push down on the orange release button (callout 2 in [Figure 14](#)).
2. While holding down the orange button, swing the black release latch toward you. Swinging the latch starts to eject the control module (callout 1) from the array. Remove the control module.

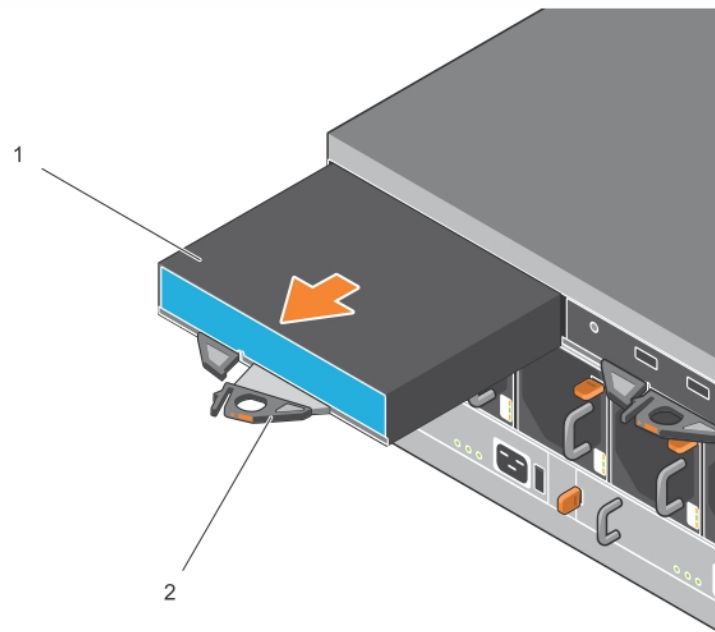
Figure 14: Removing a Control Module

3. Place the control module on a flat surface where it will be protected from electrostatic discharge. To avoid damage, do not place anything on top of the control module.
4. If you are replacing a failed control module, remove the microSD card from the failed control module and install it in the replacement control module. Using the card from the failed control module ensures that the new control module is running the correct firmware and a correct array configuration. See [Replace the microSD Card on page 25](#).

Return the failed control module in the packaging in which the replacement module was shipped. Contact your PS Series support provider for information about returning hardware.

Install a Control Module

You can install a control module without shutting down the array.

Caution: Replace control modules with the same type only. Do not mix control module types in an array.

Control modules are installed horizontally in the array, with the Ethernet ports on the right and the serial port on the left.

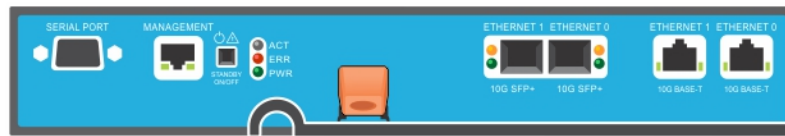
Figure 15: Correct Control Module Orientation

1. Attach an electrostatic wrist strap or similar protective device. See [Hardware Protection on page 6](#).
2. Pull up on the orange release tab (callout 2 in [Figure 16](#)) and swing the lever out.
3. Slide the control module (callout 1 in [Figure 16](#)) into the chassis until it is even with the installed controller. The lever should swing smoothly until it is in the locked position.

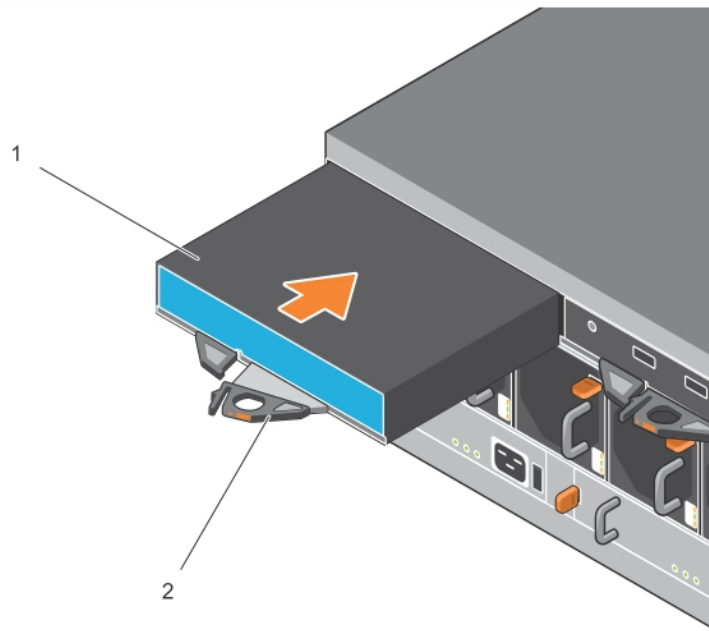
Figure 16: Installing a Control Module

4. Rotate the lever inward, which pushes the control module completely into the slot. The latch on the lever will snap into place.
5. Connect all cables (network and serial port).
6. If the array was shut down, turn on power to the array.
7. Make sure the control module is operational. See [Interpreting Control Module LEDs on page 16](#).
The Type 18 control module contains an integral battery assembly used in the cache-to-flash feature of the control module. If the Group Manager GUI or CLI indicates a battery failure, the battery must be replaced.

If two control modules are installed in the array, but only one is shown in the GUI (or CLI), make sure that you have allowed enough time (minimum of 5 minutes) for the two control modules to boot and synchronize. When synchronization completes, a message appears on the serial console (if connected), and the ACT LED on the secondary module is illuminated amber.

If the GUI (or CLI) still shows only one control module after appropriate time has elapsed, the controller might not be properly installed. Try to remove the module by rotating the black lever and reinsert the module into the array chassis. Ensure that the face of the controller is even with the controller already installed in the array.

After reinstalling the control module, if both control modules still do not appear in the GUI (or CLI), contact your support provider.

Caution: After a control module is installed in an array, do not restart or reinstall it, or upgrade firmware on the array, until the control module has finished synchronizing its internal firmware with the primary control module. This process occurs in the background and can take up to 45 minutes to complete, depending on the control module type. To verify that the synchronization process has finished, you can check for confirmation messages in the GUI event viewer or by using the CLI command `show recent events`. If you interrupt the synchronization process, you might corrupt the control module's internal firmware, and the control module will no longer function properly.

Replace the microSD Card

Each control module includes a microSD card that contains the PS Series firmware.

If a control module fails, you will need to remove the microSD card from the failed control module and install the card in the replacement control module. Using the card from the failed control module ensures that the new control module is running the same firmware and configuration as the other control module in the array.

Before you begin the procedure to replace a microSD card:

- Review [Replace a Control Module on page 21](#) for information about removing and replacing a control module.
- Attach an electrostatic wrist strap, as described in [Hardware Protection on page 6](#).

MicroSD Card Replacement Procedure

Use the following procedure for replacing the microSD card in your control module:

1. Remove the control module from the array, as described in [Remove a Control Module on page 22](#).
2. Remove the SD card from the control module, as described in [Remove the microSD Card on page 25](#).
3. Install the replacement SD card in the control module, as described in [Insert the microSD Card on page 26](#).
4. Insert the control module into the array, as described in [Install a Control Module on page 23](#).

Remove the microSD Card

Callout 1 in [Figure 17](#) shows the location of the microSD card.

Caution: To reduce the risk of losing or damaging the microSD card, do not remove it until you are ready to install it in the replacement control module.

1. Firmly push the card into its housing to release the spring mechanism (see [Figure 17](#)). The microSD card will become partially ejected from the housing.
2. Gently pull the card straight out of the housing.
3. Place the microSD card on a flat surface where it will be protected from electrostatic discharge.

Figure 17: Ejecting the MicroSD Card

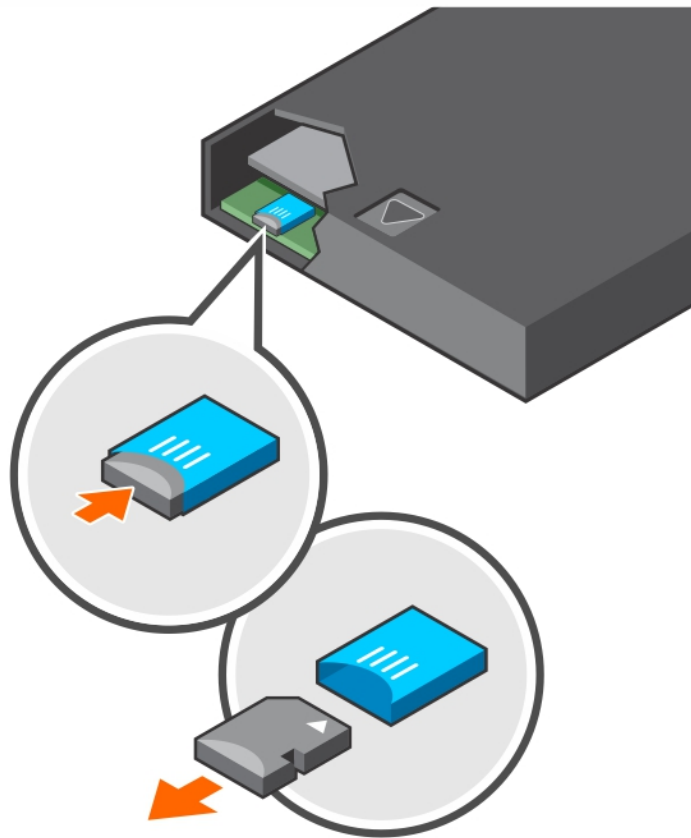

Insert the MicroSD Card

1. Align the replacement microSD card so the arrow on the card points toward the housing ([Figure 18](#)). When correctly positioned, the gold contacts will be facing downward, and inward toward the housing.
2. Firmly press the card into the housing until it clicks into place. Confirm that the card is securely seated by pressing to ensure the release spring mechanism is engaged and ejects the SD card. Then, reinsert the SD card and ensure it is seated securely by pulling gently on the SD card.

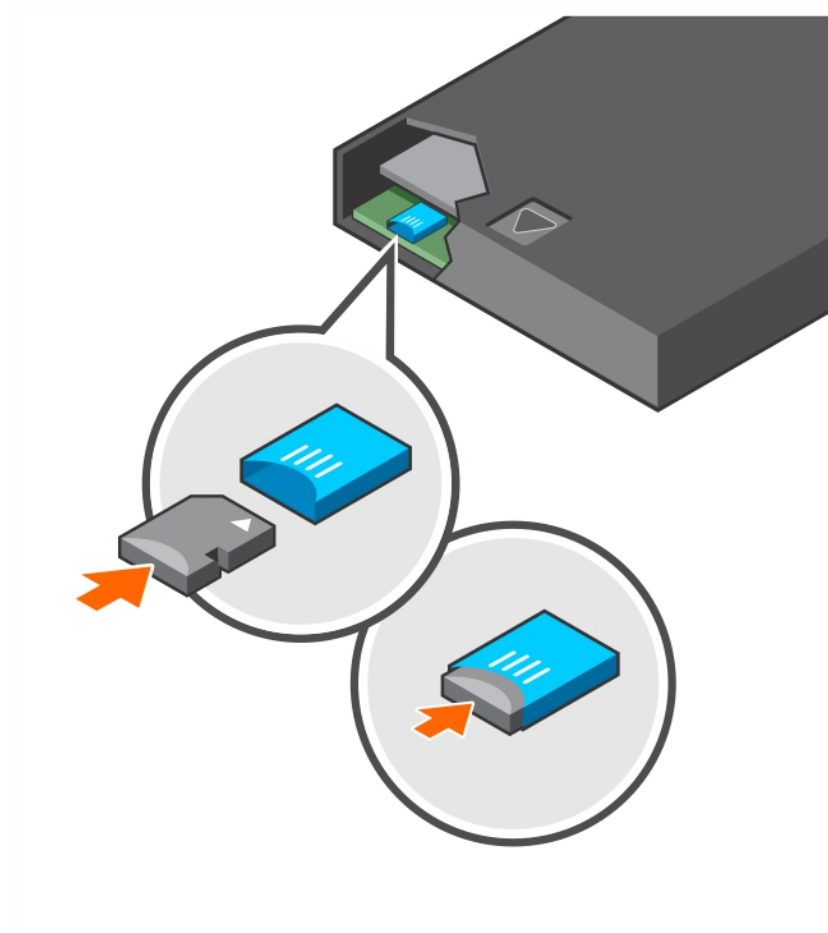
Figure 18: Inserting the MicroSD Card

3. Install the control module in the array. See [Install a Control Module on page 23](#).
4. Ensure the control module is operational. See [Interpreting Control Module LEDs on page 16](#).

Battery Replacement

This section describes the steps that must be followed when replacing the battery in a PS Series array control module.

Note: Many repairs must be done only by a certified service technician. You should perform troubleshooting and simple repairs only as authorized in your product documentation, or as directed by the online or telephone service and support team. Damage due to servicing that is not authorized by Dell is not covered by your warranty. Read and follow the safety instructions that came with your system.

Control Module Handling Requirements

Follow these control module handling requirements:

- Do not remove an active control module.

- Protect control modules from electrostatic discharge. Always wear an electrostatic wrist strap when handling a control module.

Shipping Requirements

Before you move a previously installed array to a different location, you must discharge the battery to a lower charge level. This lower level is called *ship mode* and is necessary for safety reasons. Placing the battery in ship mode minimizes charge loss while the array is in storage or being transported. Contact Dell support for assistance with placing the battery in ship mode and preparing the array for shipment.

When you reinstall the array, on first power up, you will need to wait up to 20 minutes while the batteries charge back up to 100 percent.

Before You Begin

1. Ensure that the control module that you are going to be replacing the battery on is in secondary mode. If it is active, fail the control module over so that it becomes the secondary one.

To make the control module secondary:

- a. Click `Group`.
 - b. Expand `Members` and select the member name.
 - c. Click the `Controllers` tab to display the status of the control module.
 - d. Click the `Maintenance` tab, then click `restart`.
2. If applicable, label the network cables on the secondary control module so that you can reinstall them correctly later.

Remove the Battery

1. Disconnect the network cables from the secondary control module.
2. Remove the secondary control module and place it on a static-safe work area with the battery cover facing up.
3. The battery cover, which holds the battery and related electronics, is held in place by a single screw. This screw is not captive. Loosen the screw using a Phillips #2 screwdriver (Figure 19), remove the screw from the hole, and set it aside so it does not fall inside the control module.

Figure 19: Removing the Screw From the Battery Cover

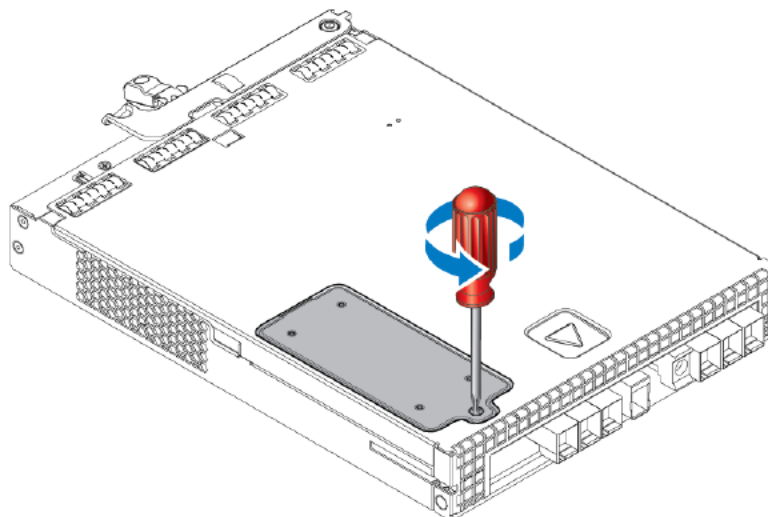

Note: If the screw falls inside the control module, you might have to return the control module to Dell for servicing.

- Using the screw tab as a handle, swing the battery cover up and to the left and lay it upside down on the control module (Figure 20). The battery cover will be heavier than expected because the battery is attached to the cover.

Figure 20: Removing the Battery Cover

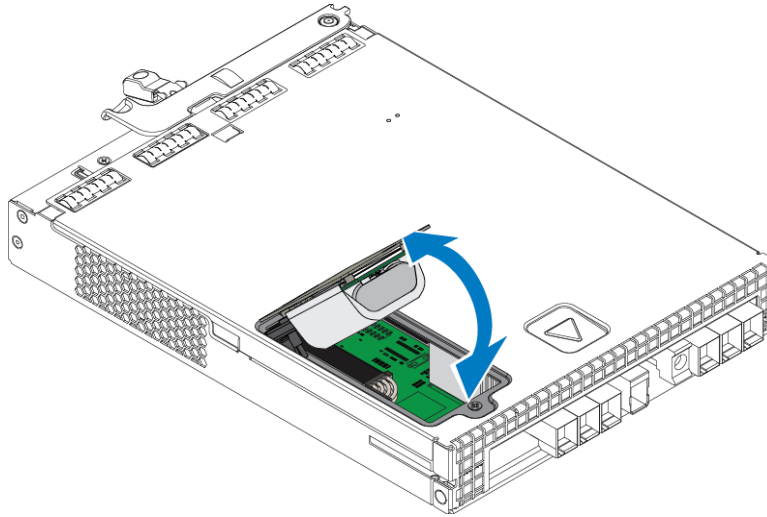

- The connector that connects to the battery unit is held in place by a retaining clip, which must be depressed to remove the connector, as shown in Figure 21. Grasp the outside of the connector, while simultaneously depressing the retaining clip, and wiggle the connector gently side to side while pulling outward to remove it. Set the old battery unit aside.

Figure 21: Disconnecting the Battery

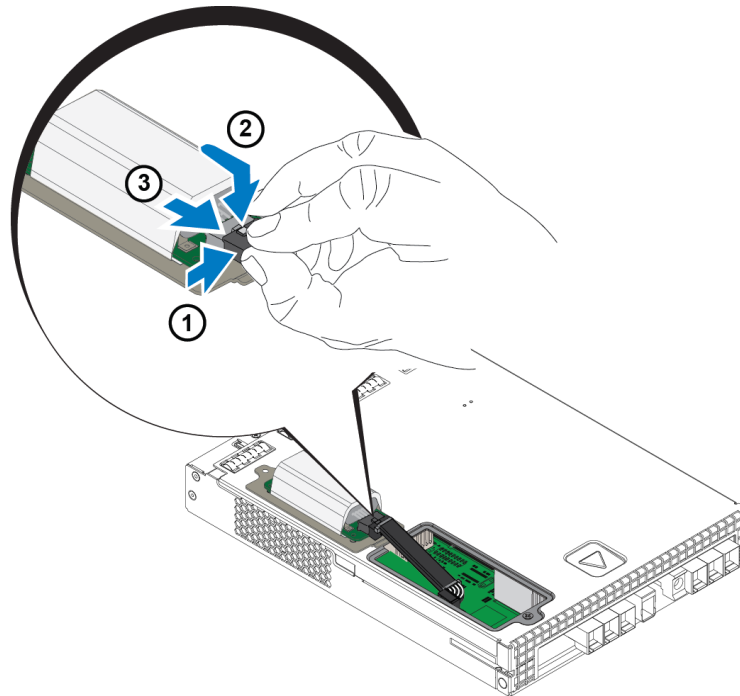

Insert the New Battery

1. Attach the new battery unit to the connector, and gently wiggle and push the connector in place to seat it. You do not need to depress the retention clip to insert the connector. When the connector is fully seated, you should hear the retention clip click into place.
2. Place the new battery unit in the chassis by reversing the procedure from step 5 for removing the battery.

Note: You might need to slightly reposition the cable inside the control module to get it out of the way and ensure easy reassembly. Make sure that the cable is not pinched between the battery cover and the control module chassis.

3. Reinsert the screw and tighten gently.
4. Reinsert the control module and reconnect the cables.

Return or Dispose of the Old Battery

The manner in which to dispose of rechargeable batteries varies by country. Make sure that you dispose of your old battery in a way that conforms to your country's regulations. Alternatively, you can return the old battery back to Dell for proper disposal. See [Shipping Requirements on page 28](#).

4 Maintain Power Supply Units

The array supports two hot-swappable power supply units.

The array is capable of operating with one power supply temporarily, but both power supplies are required to maintain long-term reliability of the array.

About Power Supplies

The PS Series array receives power from two power supply units (PSUs). The array can run on one supply while the other is in a failed state.

Each unit has a 2800W power supply that requires 200-240VAC high AC line power source.

Identifying Power Supply Failures

You can identify a power supply and cooling module failure by the following methods:

- **LEDs** on the power supply and cooling modules. See [Back-Panel Features and Indicators on page 5](#) for details.
- **Messages** on the console, in the event log, or in the Group Manager GUI Alarms panel.
- **Group Manager GUI and CLI output.** The GUI group member Enclosure tab or the CLI `member select member_name show enclosure` command shows a power supply and cooling module failure.

Note: When viewing the rear of the array, power supply 0 is on the left and power supply 1 is on the right.

Power Supply Controls and LEDs

The power supplies contain LEDs that indicate their status.

AC Power Supply

[Figure 22](#) illustrates the features of the power supply. [Table 10](#) describes these features.

Figure 22: 2800W Power Supply LEDs

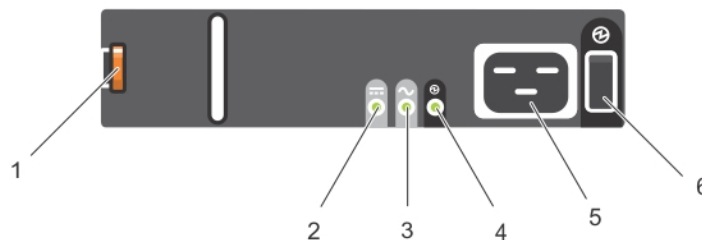

Table 10: Power Supply Features

Item	LED/Control	Color (State)	Description
1	Release latch	none	Used to remove PSU from array
2	PSU fault	Amber (steady)	PSU fault. PSU not supplying power.
		Amber (flashing)	PSU firmware is downloading
3	AC fault	Amber (steady)	AC power is not detected.
		Amber (flashing)	PSU firmware is downloading.
4	Power OK	Green (steady)	This PSU is providing power.
		Green (flashing)	AC power is present, but this PSU is in standby mode. The other PSU is providing power
5	Power Cord Connector	none	Connect the provided power cord.
6	Power Switch	(Off)	No power supplied to unit
		(On)	Unit is powered on and operational

Remove a Power Supply Unit

Although an array can operate with only one working power supply unit, you should replace the failed unit as soon as possible. For proper array cooling, do not remove a failed power supply unit until you are ready to replace it.

How to Remove a Power Supply

Wear electrostatic protection when handling a power supply and cooling module. See [Hardware Protection on page 6](#).

To remove a power supply:

1. Turn off the power switch on the power supply.
2. Disengage the hook-and-loop fastener from around the power cable.
3. Remove the power cable.
4. With your right hand, hold the handle and push the orange release latch (callout 1 in [Figure 23](#)) to the right with your thumb.
5. Pull the module from the slot, as shown in [Figure 23](#).

Caution: The PSU is heavy. Support it with two hands.

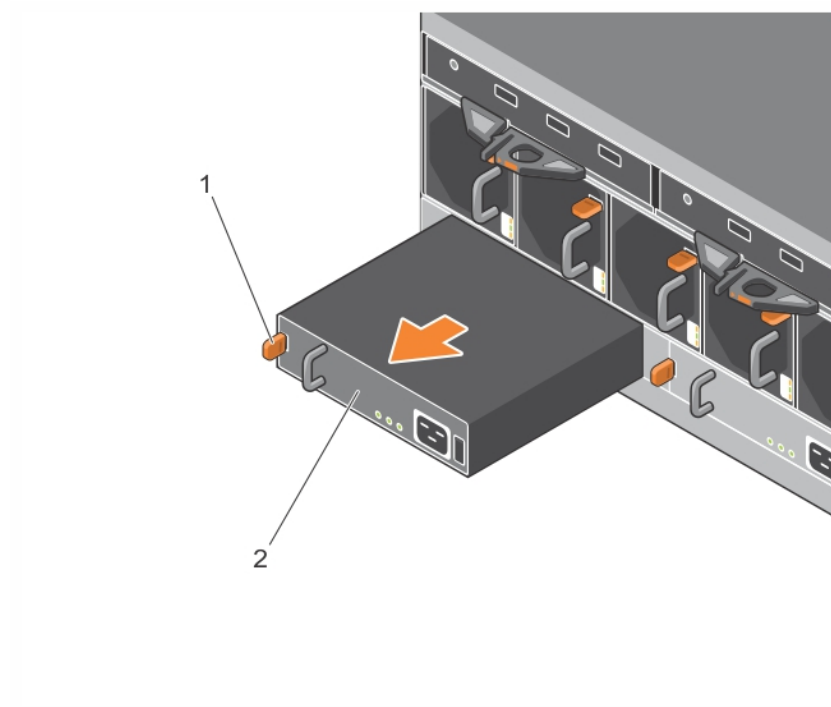
Figure 23: Removing a Power Supply Unit

Install a Power Supply Unit

To install a power supply unit:

1. Hold the power supply unit so that the orange release latch is on the upper left (callout 1 in [Figure 24](#)).
2. Slide the power supply unit into the chassis until it is fully seated and the release latch clicks into place, as illustrated in [Figure 24](#).

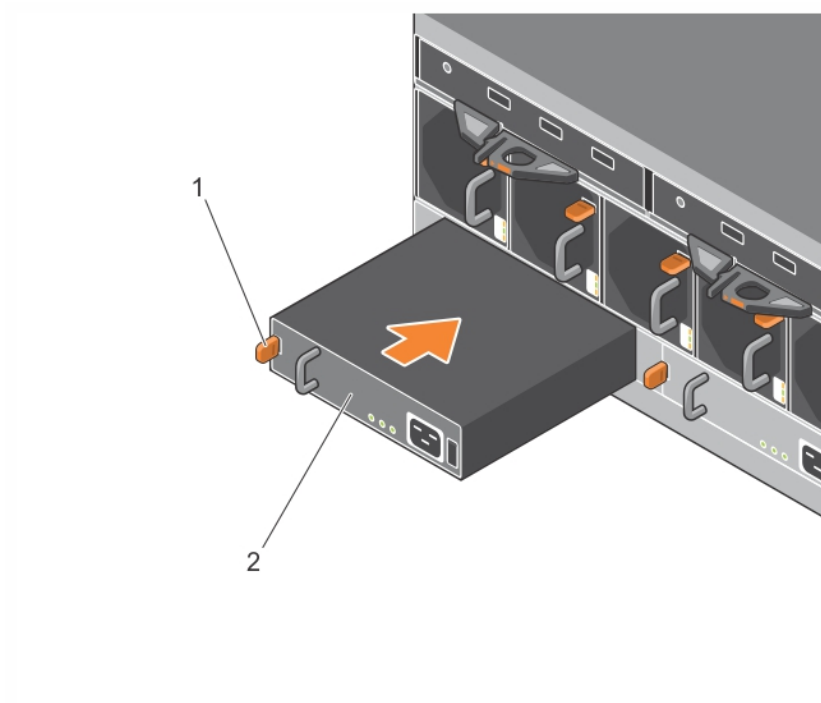
Figure 24: Inserting a Power Supply

3. Ensure the power switch is in the OFF position.
4. Connect the power cable to the power supply and cooling module and plug the cable into a power outlet.

Note: The AC LED lights up when the power cable is connected, even if the switches on the power supply are off.

5. Secure the power cable using the hook-and-loop fastener strap, as shown in [Figure 25](#).
6. Turn on the power switch on the power supply unit.

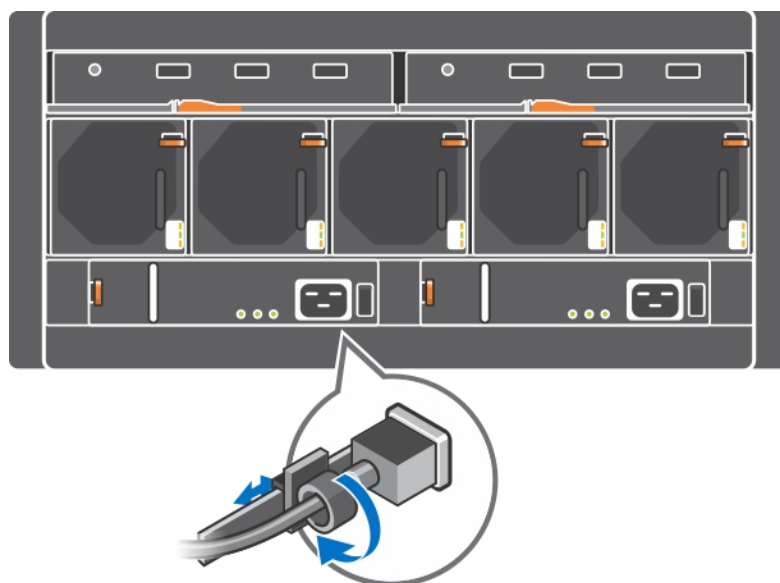
Figure 25: Securing the Power Cables

5 Maintain Fan Modules

The PS6610 array contains five cooling fan modules.

The array is capable of operating with one failed fan module; however all five cooling modules are required to maintain long-term cooling and reliability of the array.

Remove a Cooling Fan Module

Although an array can operate with only four working fan modules, you should replace the failed fan unit as soon as possible. For proper array cooling, do not remove the failed fan unit until you are ready to replace it.

Caution: The fan module replacement procedure (removal and installation) should be completed in less than 2 minutes to ensure proper cooling of the array.

How to Remove a Cooling Fan Module

Wear electrostatic protection when handling a cooling module. See [Hardware Protection on page 6](#).

To remove a cooling module:

1. From the rear of the unit, hold the handle protruding from the cooling fan and push down on the orange release latch to the right (callout 2 in [Figure 26](#)) with your thumb.
2. Pull the module from the slot, as shown in [Figure 26](#), until it is clear of the chassis.

Figure 26: Removing a Cooling Fan Module

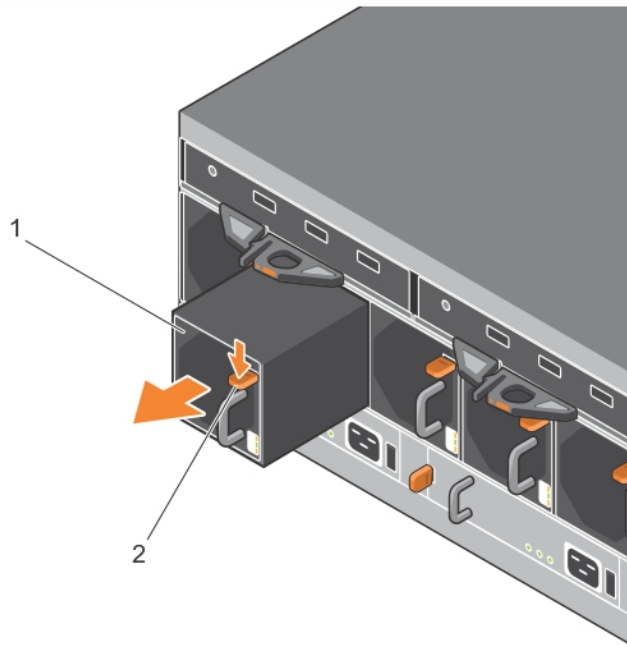

Install a Cooling Fan Module

Caution: Do not allow the array to operate for more than 2 minutes without a fan module in place to maintain proper cooling of the array.

How to Install a Cooling Fan Module

Wear electrostatic protection when handling a cooling module. See [Hardware Protection on page 6](#).

To insert a cooling module:

1. Hold the cooling modules so that the orange tab is in the upper right (callout 2 in [Figure 27](#)).
2. Slide the fan module (callout 1 in [Figure 27](#)) into the chassis until it is fully seated and the release latch clicks into place.

Figure 27: Inserting a Cooling Fan Module

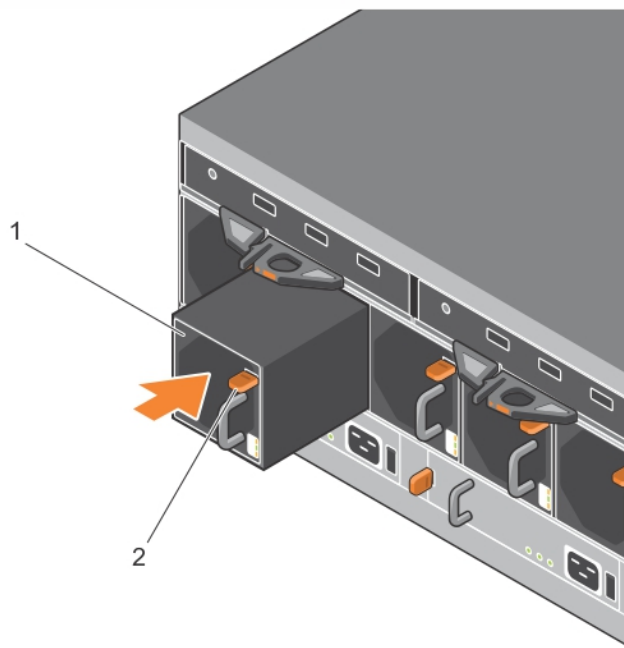

6 Advanced Networking Options

In addition to connecting all the Ethernet ports (of the same type) on both control modules to network switches, you can also optionally connect the management port to a separate network switch.

Configuring a management port enables you to separate management traffic (creating and managing the group, members, volumes, replication, and so on) from the iSCSI data traffic (I/O between applications and volumes, and between replication partners).

Configure the Management Port

Configuring the 10/100Mbps management port involves hardware steps and software steps. The management port is restricted to group management traffic only; it will not carry iSCSI I/O.

Note: Configuring this port is considered an advanced configuration, available if your environment requires this level of security.

Hardware Steps

1. Make sure your network environment can support a dedicated management network, with a subnet that is separate from the subnets for iSCSI traffic.
2. On both control modules, connect the port labeled MANAGEMENT to the management network. The location of the management port is shown in [Figure 28](#).

Figure 28: Management Port Location



Software Steps

See the *Dell EqualLogic Group Manager Administrator's Guide* for the procedure to configure the management network in the Group Manager GUI.

7 Troubleshooting Your Array

Safety First—For You and Your Array

Many repairs must be done only by a certified service technician. You should perform troubleshooting and simple repairs only as authorized in your product documentation, or as directed by the online or telephone service and support team. Damage due to servicing that is not authorized by Dell is not covered by your warranty. Read and follow the safety instructions that came with the product.

Determining Service Tag Information

Each array has an alphanumeric service tag (see [Figure 29](#)). You might need to provide this information to customer support when you contact Dell. On the PS6610, the service tag label is located on the right side of the top drawer as you face the array.

The service tag label includes a QR code. When scanned by a QR code scanner, the service tag data is used to direct you to a web site containing specific product information for your array.

Figure 29: Array Service Tag

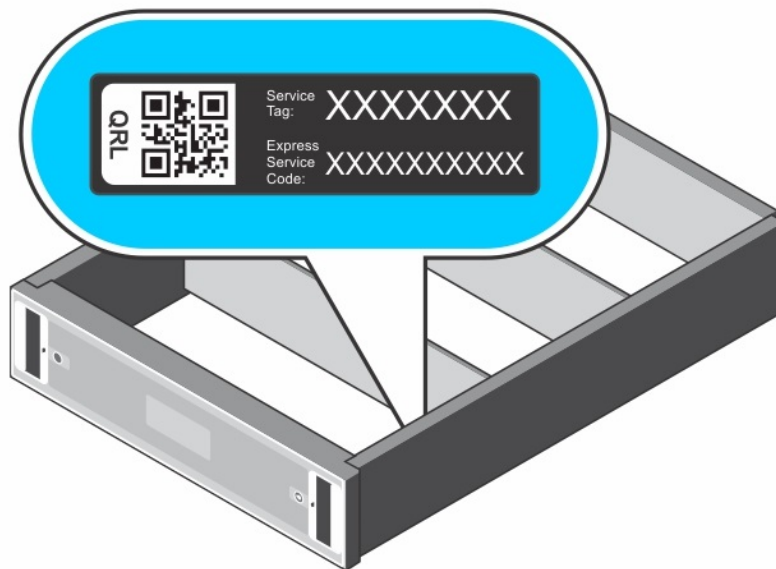

Obtaining Component Diagnostics

You can collect diagnostic information for one or more members of a PS Series group through the Group Manager GUI or the CLI. See the *Dell EqualLogic Group Manager Administrator's Guide* or the *Dell EqualLogic Group Manager CLI Reference Guide* for more information.

Array Startup Failure

If your system halts during startup, check the following areas:

- The array fault LEDs are lit. See *Front-Panel Features and Indicators on page 1*.
- A constant scraping or grinding sound occurs when you access the hard drive. See *Obtaining Technical Support and Customer Service on page v*.

Loss of Array Connections

- Verify that the control module port link status LED and the control module status LED are solid green for one of the ports in each pair as described in the *Dual Controller Configuration on page 16*. If the LEDs are not solid green, see *Control Module Features on page 15*.
- Make sure that all the cables are attached correctly.

If the problem is not resolved, see *Obtaining Technical Support and Customer Service on page v*.

Loss of External Connections

- Verify that the cables are connected to the correct Ethernet port and, if applicable, to management ports before troubleshooting any external devices.
- Make sure that the power cables are securely attached to the power supply modules on your array.

Power Supply Failure

1. Locate the faulty power supply and determine the status of the LEDs.

If the power LED is not lit, check the power cord and power source into which the power supply is connected.

- Connect another device to the power source to verify if it is working.
- Connect the cable to a different power source.
- Replace the power cable.

If the problem is not resolved, or if the power supply's fault indicator is lit, contact your PS Series support provider.

Power supply and cooling modules are hot-swappable.

Note: Dell does not recommend hot-swapping a DC power supply module.

The array can operate on a single power supply; however, both modules must be installed to ensure proper cooling. A single power supply and cooling module can be removed from a powered-on array for a maximum of 5 minutes.

2. Reseat the power supply by removing and reinstalling it. See *Remove a Power Supply Unit on page 32*.

Note: After installing a power supply, allow several seconds for the array to recognize the power supply and to determine if it is working properly.

If the problem is not resolved, contact your PS Series support provider.

Array Cooling Problems

Check for and correct any of the following situations:

- Fan failures. Review the member status in the GUI or CLI messages indicating fan failure. Fan failures require replacing a power supply unit.
- Empty drive bays or empty controller slot.

- Ambient temperature is too high. See the technical specifications for the array in the *Dell EqualLogic PS6610 Series Array Installation and Setup Guide*.
- External airflow is obstructed by cables or other items in the rack.

If the problem is not resolved, contact your PS Series support provider for a replacement.

Control Module Failures

1. Check the control module status LEDs. See [Interpreting Control Module LEDs on page 16](#) for more information.
2. Reseat the control module and wait for 30 seconds. See [Replace a Control Module on page 21](#).

If a control module fails, contact your PS Series support provider for a replacement.

Faulty Hard Drives

Check the hard drive indicators before removing the faulty drive from the array. Confirm that the drive in question is also identified as being faulty in the GUI, console log, or monitoring log.

- Remove the drive from the array and replace the drive as soon as possible. See [Remove Disk Drives on page 14](#).

If replacing the drive does not resolve the issue, contact your PS Series support provider.

Index

A

array

- control modules 15
- cooling 31, 35
- fans 31, 35
- firmware 19
- LEDs 11, 16
- power supplies 31, 35
- shutdown procedure 6

B

battery 24, 27

C

control modules

- batteries 15
- checking proper installation 25
- failover behavior 18
- failure indications 18
- features 15
- firmware requirements 19
- firmware version 19
- handling requirements 19
- installing in array 23
- LEDs 16
- locating 18
- removing from array 21
- synchronizing 19
- verifying operational status 24

cooling module

- removing PSU 32, 35-36

D

disks

- failure behavior 11
- failure indications 11
- handling requirements 9
- LEDs 11
- locating 11

- protecting 9
- verifying operational status 13

E

electrostatic discharge 6

electrostatic wrist strap 6

F

failover

- control module 18

failure indications

- control modules 18
- disks 11

fans

- removing PSU 32, 35-36

firmware

- identifying version 19
- requirements 19

I

identifying the firmware version 19

installing

- power supply/cooling fan module 33

L

LEDs

- control module 16
- disks 11
- network interfaces 16

M

microSD card

- firmware requirements 19
- inserting 26
- removing 25
- replacing 19

N**network**

failure protection [18](#)

network interfaces

LEDs [16](#)

P**power supplies**

removing [32, 35-36](#)

PS Series array

protecting from discharge [6](#)

Q

QR code [39](#)

R

recommended tools [6](#)

removing

3.5-inch drive [14](#)

requirements

control modules [19](#)

cooling [32, 35-36](#)

disks [9](#)

firmware [19](#)

power [32, 35-36](#)

S

safety [39](#)

SD card [15](#)

service tag [39](#)

ship mode [28](#)

shutting down an array [6](#)

standby button [19](#)

status

control modules [18](#)

T

Technical Support [v](#)

troubleshooting [39](#)

connections [40](#)

cooling problems [40](#)

external connections [40](#)

power supply/cooling fan module [40](#)

startup failure [39](#)

V

vertical failover [16](#)