

Profile Registration Profile

Document Number: DCIM1051
Document Type: Specification
Document Status: Published
Document Language: E
Date: 2012-03-08

Version: 1.0.0



THIS PROFILE IS FOR INFORMATIONAL PURPOSES ONLY, AND MAY CONTAIN TYPOGRAPHICAL ERRORS AND TECHNICAL INACCURACIES. THE CONTENT IS PROVIDED AS IS, WITHOUT EXPRESS OR IMPLIED WARRANTIES OF ANY KIND. ABSENT A SEPARATE AGREEMENT BETWEEN YOU AND DELL™ WITH REGARD TO FEEDBACK TO DELL ON THIS PROFILE SPECIFICATION, YOU AGREE ANY FEEDBACK YOU PROVIDE TO DELL REGARDING THIS PROFILE SPECIFICATION WILL BE OWNED AND CAN BE FREELY USED BY DELL.

© 2012 Dell Inc. All rights reserved. Reproduction in any manner whatsoever without the express written permission of Dell, Inc. is strictly forbidden. For more information, contact Dell.

Dell and the *DELL* logo are trademarks of Dell Inc. *Microsoft* and *WinRM* are either trademarks or registered trademarks of Microsoft Corporation in the United States and/or other countries. Other trademarks and trade names may be used in this document to refer to either the entities claiming the marks and names or their products. Dell disclaims proprietary interest in the marks and names of others.

CONTENTS

1	Scope	5
2	Normative References.....	5
3	Terms and Definitions	6
4	Symbols and Abbreviated Terms	7
5	Synopsis.....	8
6	Description	8
7	Implementation Requirements	9
	7.1 DCIM_RegisteredProfile	10
	7.2 DCIM_LCRegisteredProfile	12
8	Methods.....	15
9	Use Cases.....	15
10	CIM Elements.....	15
11	Privilege and License Requirement	15

Figures

Figure 1 – Class Diagram	8
Figure 2 – Implementation Object Diagram	9

Tables

Table 1 – Class Requirements: Profile Registration Profile	9
Table 2 – DCIM_RegisteredProfile - Operations	10
Table 3 – DCIM_RegisteredProfile - Properties.....	10
Table 4 – DCIM_RegisteredProfile – DMTF Profile List	11
Table 5 – DCIM_LCRegisteredProfile - Operations.....	13
Table 6 – DCIM_LCRegisteredProfile - Properties.....	13
Table 7 – DCIM_LCRegisteredProfile – DCIM Profile List	13
Table 8 – Privilege and License Requirements	15

1 Scope

The DCIM *Profile Registration* Profile defines the classes used to describe the DCIM and DMTF profile registration and the version information of the profiles advertised as implemented for a managed system and components of the system. The information in this specification is intended to be sufficient for a provider or consumer of this data to identify unambiguously the classes, properties, methods, and values that must be instantiated to represent the profile name, version, and owning organization information that is modeled using the DMTF Common Information Model (CIM) Schema.

The *Profile Registration* Profile extends the management capability of the referencing profiles by adding the capability to describe the registration and versioning of Common Information Model (CIM) profiles that are implemented by CIM-based system and component-management instrumentation.

2 Normative References

Refer to the following documents for more information.

NOTE: For dated references, only the edition cited applies. For undated references, the latest edition of the referenced document (including any amendments) applies.

- DMTF DSP1061, *Management Profile 1.0.0*
- DMTF DSP0200, *CIM Operations over HTTP 1.2.0*
- DMTF DSP0004, *CIM Infrastructure Specification 2.3.0*
- DMTF DSP1000, *Management Profile Specification Template*
- DMTF DSP1001, *Management Profile Specification Usage Guide*
- DMTF DSP0226, *Web Services for Management (WS-Management) Specification 1.1.0*
- DMTF DSP0227, *WS-Management CIM Binding Specification 1.0.0*
- *Dell Lifecycle Controller Best Practices Guide 1.0*,
http://en.community.dell.com/techcenter/extras/m/white_papers/20066173.aspx
- *Dell WSMAN Licenses and Privileges 1.0*
- ISO/IEC Directives, Part 2, *Rules for the structure and drafting of International Standards*,
<http://isotc.iso.org/livelink/livelink.exe?func=ll&objId=4230456&objAction=browse&sort=subtype>
- Unified Modeling Language (UML) from the Open Management Group (OMG),
<http://www.uml.org>
- Dell Tech Center MOF Library:
<http://www.delltechcenter.com/page/DCIM.Library.MOF>
- Related Managed Object Format (MOF) files:
 - DCIM_LCElementConformsToProfile
 - DCIM_ElementConformsToProfile
 - DCIM_RegisteredProfile
 - DCIM_LCRegisteredProfile

36 **3 Terms and Definitions**

37 For the purposes of this document, the following terms and definitions apply.

38 **3.1**

39 **Conditional** – Indicates requirements to be followed strictly in order to conform to the document when the
40 specified conditions are met.

41 **3.2**

42 **Mandatory** – Indicates requirements to be followed strictly in order to conform to the document and from
43 which no deviation is permitted.

44 **3.3**

45 **May** – Indicates a course of action permissible within the limits of the document.

46 **3.4**

47 **Optional** – Indicates a course of action permissible within the limits of the document.

48 **3.5**

49 **can** – Used for statements of possibility and capability, whether material, physical, or causal.

50 **3.6**

51 **cannot** – Used for statements of possibility and capability, whether material, physical, or causal.

52 **3.7**

53 **need not** – Indicates a course of action permissible within the limits of the document.

54 **3.8**

55 **referencing profile** – Indicates a profile that owns the definition of this class and can include a reference
56 to this profile in its “Related Profiles” table.

57 **3.9**

58 **shall** – Indicates requirements to be followed strictly in order to conform to the document and from which
59 no deviation is permitted.

- 60 **3.10**
61 **shall not** – Indicates requirements to be followed strictly in order to conform to the document and from
62 which no deviation is permitted.
- 63 **3.11**
64 **should** – Indicates that among several possibilities, one is recommended as particularly suitable, without
65 mentioning or excluding others, or that a certain course of action is preferred but not necessarily required.
- 66 **3.12**
67 **should not** – Indicates that a certain possibility or course of action is deprecated but not
68 prohibited
- 69 **3.13**
70 **FQDD** – Fully Qualified Device Descriptor is used to identify a particular component in a system.
- 71 **3.14**
72 **Interop Namespace** – Interop Namespace is where instrumentation instantiates classes to advertise its
73 capabilities for client discovery.
- 74 **3.15**
75 **Implementation Namespace** – Implementation Namespace is where instrumentation instantiates
76 classes relevant to executing core management tasks.
- 77 **3.16**
78 **ENUMERATE** – Refers to WS-MAN `ENUMERATE` operation as described in Section 8.2 of
79 DSP0226_V1.1 and Section 9.1 of DSP0227_V1.0
- 80 **3.17**
81 **GET** – Refers to WS-MAN `GET` operation as defined in Section 7.3 of DSP00226_V1.1 and Section 7.1
82 of DSP0227_V1.0

83 **4 Symbols and Abbreviated Terms**

- 84 **4.1**
85 **CIM -Common Information Model**
- 86 **4.2**
87 **iDRAC** - Integrated Dell Remote Access Controller – management controller for blades and monolithic
88 servers
- 89 **4.3**
90 **CMC** - Chassis Management Controller – management controller for the modular chassis
- 91 **4.4**
92 **WBEM** - Web-Based Enterprise Management
93
94

95 **5 Synopsis**

96 **Profile Name:** Profile Registration

97 **Version:** 1.0.0

98 **Organization:** DCIM

99 **CIM Schema Version:** 2.26 Experimental

100 **Central Class:** DCIM_RegisteredProfile & DCIM_LCRegisteredProfile

101 **Scoping Class:** CIM_RegisteredProfile

102 The *Profile Registration* Profile defines the classes used to describe the DMTF profile registration and the
103 version information of the profiles advertised as implemented for a managed system and components of
104 the system.

105 **6 Description**

106 Profile Registration Profile describes the profile advertisements of the managed accesspoint. The profiles
107 implemented on the managed accesspoint are represented by the CIM_RegisteredProfile instances in the
108 Interop Namespace.

109 Figure 2 represents the class schema for the Profile Registration Profile. For simplicity, the prefix CIM_ is
110 removed from the names of the classes.

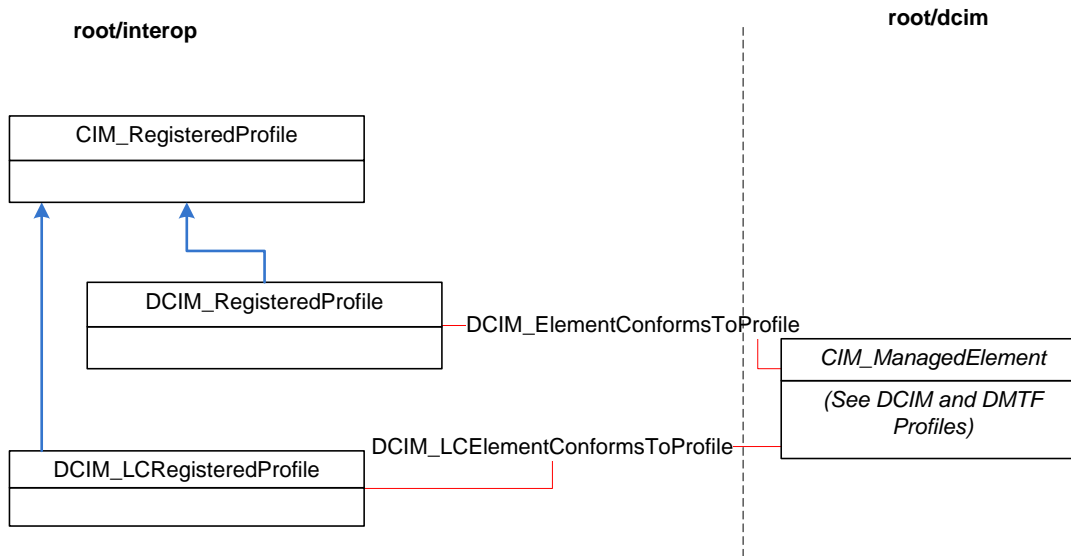

111

112

Figure 1 – Class Diagram

113 Figure 2 details the typical implementation for the Profile Registration Profile.

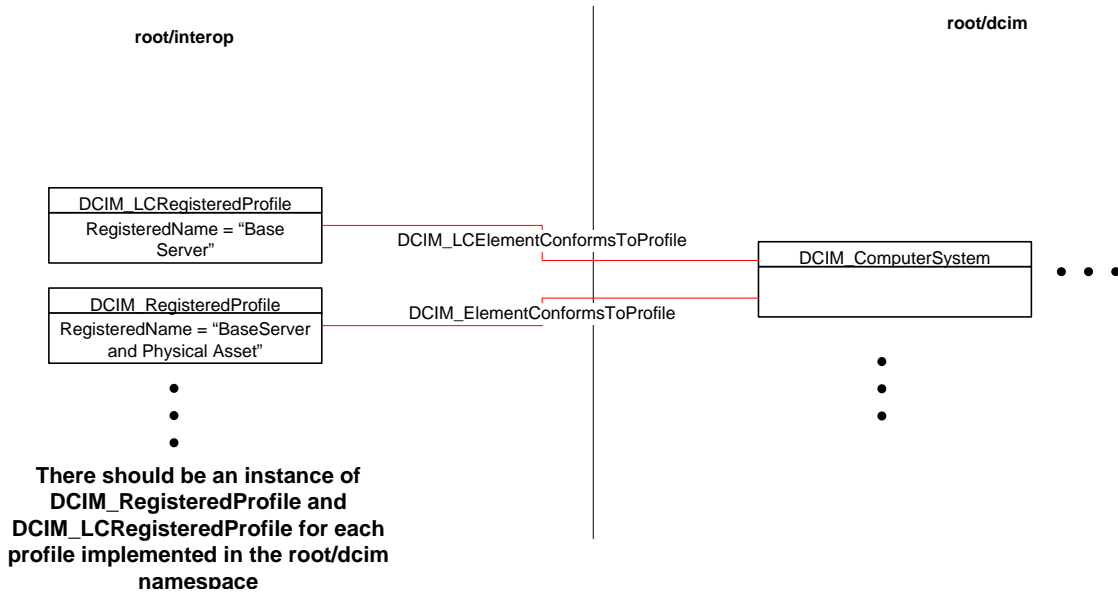

114

115

Figure 2 – Implementation Object Diagram

116 7 Implementation Requirements

117 This section describes the requirements and guidelines for implementing Profile Registration Profile.

118 **Table 1 – Class Requirements: Profile Registration Profile**

Element Name	Requirement	Description
Classes		
DCIM_RegisteredProfile	Mandatory	The class shall be implemented in the <i>Interop Namespace: root/interop</i> . See section 7.1
DCIM_ElementConformsToProfile	Mandatory	The class shall be implemented in both the <i>Interop Namespace: root/interop</i> and <i>Implementation Namespace: root/dcims</i> . See section 7.1.
DCIM_LCRegisteredProfile	Mandatory	The class shall be implemented in the <i>Interop Namespace: root/interop</i> . See section 7.2.
DCIM_LCElementConformsToProfile	Mandatory	The class shall be implemented in both the <i>Interop Namespace: root/interop</i> and <i>Implementation Namespace: root/dcim</i> . See section 7.2.
Indications		
None defined in this profile		

119

120 7.1 DCIM_RegisteredProfile

121 This section describes the implementation for the CIM_RegisteredProfile class that represents the
122 registration of the DMTF profiles in the Interop Namespace.

123 This class shall be instantiated in the Interop Namespace (root/interop).

124 The DCIM_ElementConformsToProfile shall reference the “Central Class” class listed in the Table 4 and
125 the corresponding DCIM_RegeisteredProfile instance.

126 7.1.1 Resource URIs for WinRM®

127 The class Resource URI shall be “http://schemas.dell.com/wbem/wscim/1/cim-
128 schema/2/DCIM_RegisteredProfile?__cimnamespace=root/interop”

129 The key property shall be the InstanceID.

130 The instance Resource URI for DCIM_RegisteredProfile instance shall be:
131 “http://schemas.dell.com.org/wbem/wscim/1/cim-
132 schema/2/DCIM_LCRegisteredProfile?__cimnamespace=root/interop+InstanceID=<InstanceID value
133 from Table 1>”

134 7.1.2 Operations

135 The following table lists the operations implemented on DCIM_RegisteredProfile.

136 **Table 2 – DCIM_RegisteredProfile - Operations**

Operation Name	Requirements	Required Input
Get	Mandatory	Instance URI
Enumerate	Mandatory	Class URI

137 7.1.3 Class Properties

138 The following table lists the implemented properties for DCIM_RegisteredProfile instance in a system.
139 The “Requirements” column shall denote whether the property is implemented (for requirement
140 definitions, see section 3). The “Additional Requirements” column shall denote either possible values for
141 the property, or requirements on the value formulation.

142 **Table 3 – DCIM_RegisteredProfile - Properties**

Property Name	Requirement	Type	Requirement and description
InstanceID	Mandatory	String	The property value shall be the InstanceID of the corresponding profile row from Table 4.
RegisteredName	Mandatory	String	The property value shall be the “Profile Name” column of the corresponding profile from Table 4.
RegisteredVersion	Mandatory	String	The property value shall be the “Version” column of the corresponding profile row from Table 4.
RegisteredOrganization	Mandatory	uint16	The property value shall be 2 (DMTF).
AdvertiseTypes[]	Mandatory	uint16	The property value shall be 1 (Other)
AdvertiseTypeDescriptions[]	Mandatory	String[]	The property array shall contain “WS-Identify” and “Interop Namespace” strings.

143 Table 4 lists the DMTF profiles in the “Profile Name” column with the corresponding Central Classes of
 144 those profiles in the “Central Class” column. The “InstanceID” and “Version” columns correspond to the
 145 DCIM_RegisteredProfile’s InstanceID and RegisteredVersion properties respectively.

146 **Table 4 – DCIM_RegisteredProfile – DMTF Profile List**

Profile Name	Central Class	InstanceID	Version
Base Metrics	DCIM_MetricService	DCIM:BaseMetricsRegisteredProfile:1	1.0.0
Base Server	DCIM_ComputerSystem	DCIM:CSRegisteredProfile:1	1.0.0
CLP Service	DCIM_CLPProtocolService	DCIM:CLPProtocolServiceRegisteredProfile:1	1.0.0
Physical Asset	DCIM_Chassis	DCIM:PhysicalAssetRegisteredProfile:1	1.0.0
Power State Management	DCIM_CSPowerManagementService	DCIM:PowerStateManagementRegisteredProfile:1	2.0.0
Power Supply	DCIM_PowerSupply	DCIM:PowerSupplyRegisteredProfile:1	1.1.0
Profile Registration	DCIM_RegisteredProfile	DCIM:Profile Registration Profile	1.0.0
Record Log	DCIM_LCRecordLog & DCIM_SELRecordLog	DCIM:RecordLogRegisteredProfile:1	1.0.0
Record Log	DCIM_LCRecordLog	DMTF:RecordLog:2.0.0	2.0.0
Role Based Authorization	DCIM_LocalUserAccountManagementService & DCIM_IPMIAccountManagementService & DCIM_CLPAccountManagementService	DCIM:SimpleIdentityRegisteredProfile:1	1.0.0
Sensors	DCIM_Sensor & DCIM_PSNumericSensor & DCIM_Numeric Sensor	DMTF:Sensors:1.0.0	1.0.0
Service Processor	DCIM_SPCComputerSystem	DCIM:SPRegisteredProfile:1	1.0.0
Simple Identity Management	DCIM_LocalRoleBasedAuthorizationService & DCIM_IPMIRoleBasedAuthorizationService & DCIM_CLPRoleBasedAuthorizationService	DCIM:RoleBasedAuthorizationRegisteredProfile:1	1.0.0
SM CLP Admin Domain	DCIM_AdminDomain	DCIM:SMCLPAdminDomainRegisteredProfile:1	1.0.0

Profile Name	Central Class	InstanceID	Version
SMASH Collections	DCIM_CSCapabilitiesConcreteCollection & DCIM_CSCapacitiesConcreteCollection & DCIM_CSSettingsConcreteCollection & DCIM_CSConsolesConcreteCollection & DCIM_CSLogsConcreteCollection & DCIM_CSSensorsConcreteCollection & DCIM_ADMPProfilesConcreteCollection & DCIM_SPCapabilitiesConcreteCollection & DCIM_SPCapacitiesConcreteCollection & DCIM_SPSettingsConcreteCollection & DCIM_SPConsolesConcreteCollection & DCIM_SPLogsConcreteCollection & DCIM_SPSensorsConcreteCollection	DCIM:SMASHCollectionsRegisteredProfile:1	1.0.0

147 **7.2 DCIM_LCRegisteredProfile**

148 This section describes the implementation for the CIM_RegisteredProfile class that represents the
149 registration of the DMTF profiles in the Interop Namespace.

150 This class shall be instantiated in the Interop Namespace (root/interop).

151 The DCIM_ElementConformsToProfile shall reference the “Central Class” class listed in the Table 7 and
152 the corresponding DCIM_RegeisteredProfile instance.

153 **7.2.1 Resource URIs for WinRM®**

154 The class Resource URI shall be
155 “http://schemas.dell.com/wbem/wscim/1/cim-
156 schema/2/DCIM_LCRegisteredProfile?__cimnamespace=root/interop”

157 The key property shall be the InstanceID.

158 The instance Resource URI for DCIM_LCRegisteredProfile instance shall be:
159 “http://schemas.dell.com/wbem/wscim/1/cim-
160 schema/2/DCIM_LCRegisteredProfile?__cimnamespace=root/interop+InstanceID=<InstanceID value
161 from Table 1>”

162 **7.2.2 Operations**

163 The following table lists the operations implemented on DCIM_LCRegisteredProfile.

164

Table 5 – DCIM_LCRegisteredProfile - Operations

Operation Name	Requirements	Required Input
Get	Mandatory	Instance URI
Enumerate	Mandatory	Class URI

165 **7.2.3 Class Properties**

166 The following table lists the implemented properties for DCIM_LCRegisteredProfile instance in a system.
 167 The “Requirements” column shall denote whether the property is implemented (for requirement
 168 definitions, see section 3). The “Additional Requirements” column shall denote either possible values for
 169 the property, or requirements on the value formulation.

170

Table 6 – DCIM_LCRegisteredProfile - Properties

Property Name	Requirement	Type	Additional Requirements
InstanceID	Mandatory	String	The property value shall be from InstanceID of the corresponding profile row from Table 7.
RegisteredName	Mandatory	String	The property value shall be from “RegisteredName” of the corresponding profile from Table 7.
RegisteredVersion	Mandatory	String	The property value shall be from “Version” column of the corresponding profile row from Table 7.
RegisteredOrganization	Mandatory	uint16	The property value shall be 1 (Other).
OtherRegisteredOrganization	Mandatory	String	The property value shall be “DCIM”.
AdvertiseTypes[]	Mandatory	uint16	The property value shall be 1 (Other)
AdvertiseTypeDescriptions[]	Mandatory	String	The property array shall contain “WS-Identify” and “Interop Namespace” strings.
ProfileRequireLicense[]	Mandatory	String	This property array shall describe the required licenses for this profile. If no license is required for the profile, the property shall have value NULL.
ProfileRequireLicenseStatus[]	Mandatory	String	This property array shall contain the status for the corresponding license in the same element index of the ProfileRequireLicense array property. Each array element shall contain: <ul style="list-style-type: none"> • “LICENSED” • “NOT_LICENSED” If no license is required for the profile, the property shall have value NULL.

171 Table 7 lists the DCIM profiles in the “Profile Name” column with the corresponding Central Classes of
 172 those profiles in the “Central Class” column. The “DMTF Specialization” column denotes whether the
 173 corresponding DCIM profile specializes from DMTF profile(s) or not. The “InstanceID” and “Version”
 174 columns correspond to the DCIM_LCRegisteredProfile’s InstanceID and RegisteredVersion properties
 175 respectively.

176

Table 7 – DCIM_LCRegisteredProfile – DCIM Profile List

Profile Name	Central Class	InstanceID	Version	DMTF Specialization
--------------	---------------	------------	---------	---------------------

Profile Name	Central Class	InstanceID	Version	DMTF Specialization
Base Metrics	DCIM_MetricService	DCIM:BaseMetrics:1.0.0	1.1.0	Yes
Base Server and Physical Asset	DCIM_ComputerSystem	DCIM:BaseServerandPhysicalAsset:1.0.0	1.0.0	Yes
BIOS and Boot Management	DCIM_BIOSService	DCIM:BIOSandBootManagement:1.0.0	1.2.0	No
CPU	DCIM_CPUView	DCIM:CPU:1.0.0	1.0.0	No
Event Filter	DCIM_EFConfigurationService	DCIM:EventFilter:1.0.0	1.0.0	No
Fan	DCIM_FanView	DCIM:Fan:1.0.0	1.0.0	No
iDRAC Card	DCIM_iDRACCardView	DCIM:iDRACCard:1.0.0	1.2.0	No
Job Control	DCIM_JobService	DCIM:JobControl:1.0.0	1.2.0	No
LC Management	DCIM_LCService	DCIM:LCManagement:1.1.0	1.5.0	No
License Management	DCIM_LicenseManagementService	DCIM:LicenseManagement:1.0.0	1.0.0	No
Memory	DCIM_MemoryView	DCIM:Memory:1.0.0	1.1.0	No
OS Deployment	DCIM_OSDeploymentService	DCIM:OSDeployment:1.1.0	1.4.0	No
PCI Device	DCIM_PCIDeviceView	DCIM:PCI Device:1.0.0	1.0.0	No
Persistent Storage	DCIM_PersistentStorageService	DCIM:PersistentStorage:1.0.0	1.0.0	No
Power State Management	DCIM_CSPowerManagementService	DCIM:PowerStateManagement:1.0.0	1.0.0	Yes
Power Supply	DCIM_PowerSupplyView	DCIM:PowerSupply:2.0.0	2.1.0	No
Record Log	DCIM_LCRecordLog & DCIM_SELRecordLog	DCIM:RecordLog:1.0.0	1.0.0	Yes
Role Based Authorization	DCIM_LocalRoleBasedAuthorizationService & DCIM_IPMIRoleBasedAuthorizationService & DCIM_CLPRoleBasedAuthorizationService	DCIM:RoleBasedAuthorization:1.0.0	1.0.0	Yes
Sensors	DCIM_Sensor & DCIM_PSNumericSensor & DCIM_Numeric Sensor	DCIM:Sensors:1.0.0	1.0.0	Yes
Service Processor	DCIM_SPComputerSystem	DCIM:ServiceProcessor:1.0.0	1.0.0	Yes
Simple Identity Management	DCIM_LocalUserAccountManagementService & DCIM_IPMIAccountManagementService & DCIM_CLPAccountManagementService	DCIM:SimpleIdentityManagement:1.0.0	1.0.0	Yes
Simple NIC	DCIM_NICService	DCIM:SimpleNIC:1.0.0	1.2.0	No
Simple RAID	DCIM_RAIDService	DCIM:SimpleRAID:1.0.0	1.2.0	No
Software Inventory	DCIM_SoftwareIdentity	DCIM:SoftwareInventory:1.0.0	1.1.0	No
Software Update	DCIM_SoftwareInstallationService	DCIM:SoftwareUpdate:1.0.0	1.0.0	No
System Info	DCIM_SystemView	DCIM:SystemInfo:1.0.0	1.3.0	No
Video	DCIM_VideoView	DCIM:Video:1.0.0	1.0.0	No

178

179 **8 Methods**

180 There are no extrinsic methods for this profile.

181 **9 Use Cases**

182 See *Lifecycle Controller (LC) Integration Best Practices Guide*.

183 **10 CIM Elements**

184 No additional requirements are defined.

185 **11 Privilege and License Requirement**

186 The following table describes the privilege and license requirements for the listed operations. For the
187 detailed explanation of the privileges and licenses, refer to the Dell WSMAN Licenses and Privileges
188 specification.

189 **Table 8 – Privilege and License Requirements**

Class and Method	Operation	User Privilege Required	License Required
DCIM_RegisteredProfile	ENUMERATE, GET	Login	None.
DCIM_ElementConformsToProfile	ENUMERATE, GET	Login	None.
DCIM_LCRegisteredProfile	ENUMERATE, GET	Login	None.
DCIM_LCElementConformsToProfile	ENUMERATE, GET	Login	None.

190

191