

# Microsoft Windows Server 2012 R2 - Hyper-V on Dell PowerEdge VRTX Deployment Guide



# Notes, cautions, and warnings

 **NOTE:** A NOTE indicates important information that helps you make better use of your computer.

 **CAUTION:** A CAUTION indicates either potential damage to hardware or loss of data and tells you how to avoid the problem.

 **WARNING:** A WARNING indicates a potential for property damage, personal injury, or death.

**Copyright © 2015 Dell Inc. All rights reserved.** This product is protected by U.S. and international copyright and intellectual property laws. Dell™ and the Dell logo are trademarks of Dell Inc. in the United States and/or other jurisdictions. All other marks and names mentioned herein may be trademarks of their respective companies.

2015 - 07

Rev. A00

# Contents

<b>1 Abbreviations.....</b>	<b>5</b>
<b>2 Audience.....</b>	<b>6</b>
<b>3 Scope.....</b>	<b>7</b>
<b>4 Overview.....</b>	<b>8</b>
<b>5 Solution requirements.....</b>	<b>9</b>
Hardware requirements.....	9
Software requirements.....	9
Firmware requirements.....	10
Cabling requirements.....	10
<b>6 Hyper-V on the Dell PowerEdge VRTX chassis— deployment workflow.....</b>	<b>13</b>
<b>7 Configuring components.....</b>	<b>15</b>
Configuring Dell Networking R1-2210 switch module.....	15
Configuring PowerEdge VRTX chassis CMC and PowerEdge M630 servers for OOB management.....	16
Configuring BIOS on the PowerEdge M630 server.....	17
Configuring the VRTX storage.....	17
Assigning virtual adapters to server slots.....	17
Creating virtual disks.....	18
Initializing virtual disks.....	18
Assigning global hot spares.....	18
<b>8 Configuring solution for virtualization – Windows Server 2012 R2 Hyper-V.....</b>	<b>20</b>
Installing virtualization infrastructure.....	20
Configuring virtual disk for OS deployment in Dell PowerEdge M630 servers.....	20
Configuring prerequisites to install Windows Server.....	21
Mapping to virtual disk.....	21
Setting boot device and loading the OS executable files.....	21
Installing Windows Server 2012 R2 operating system in the Dell PowerEdge VRTX .....	21
Enabling Hyper-V and multipath features in Windows Server 2012 R2.....	21
Setting up NIC teaming in Windows Server 2012 R2 .....	22

Configuring network in Windows Server 2012 R2.....	22
Sample naming and IP addressing scheme .....	23
Configuring vEthernet switch in Windows Server 2012 R2.....	23
Adding the Dell PowerEdge VRTX servers to the domain.....	24
Assigning virtual disks.....	24
Installing the shared PERC driver.....	24
Adding MPIO settings in Windows Server 2012 R2.....	25
Configuring registry.....	25
Adding volumes in the Dell PowerEdge M630 servers.....	25
Enabling failover clustering in Windows Server 2012 R2.....	26
Creating cluster.....	26
Validating configuration.....	26
Creating a Hyper-V host cluster in VMM.....	26
<b>9 Verifying the deployment.....</b>	<b>29</b>
<b>10 Appendix A.....</b>	<b>30</b>
<b>11 Appendix B.....</b>	<b>31</b>

# Abbreviations

Table 1. Abbreviations

Abbreviations	Definition
bNDC	blade Network Daughter Card
CLI	command-line interface
CMC	Chassis Management Controller
CPLD	complex programmable logic device
Dell RACADM	Dell Remote Access Controller Admin
EULA	End User License Agreement
iDRAC8	integrated Dell Remote Access Controller
LUN	logical unit number
VM	virtual machine
VMM	Virtual Machine Manager
WFE	Web Front-end

## Audience

This guide is intended for IT professionals and administrators who want to deploy the virtualized infrastructure solution by using Windows Server 2012 R2 Hyper-V on the Dell PowerEdge VRTX chassis.

## Scope

This guide presents a highly available infrastructure that is designed according to the best practices and recommendations for virtualizing applications.

This guide provides step-by-step information on deploying a solution for general purpose virtual infrastructure using Microsoft Windows Server 2012 R2 Hyper-V on the Dell PowerEdge VRTX architecture. The verification of the infrastructure for component failovers is described in the verifying deployment section.

This guide provides information on setting up and configuring the following components that are part of the solution infrastructure:

- Dell Networking R1-2210 10GbE Switch Module
- Dell PowerEdge VRTX Chassis and Dell PowerEdge M630 Servers

# Overview

Hyper-V on the Dell PowerEdge VRTX solution enables you to deploy virtualization-enabled remote office or branch office environments (ROBO) using Windows Server 2012 R2 on the Dell PowerEdge VRTX chassis.

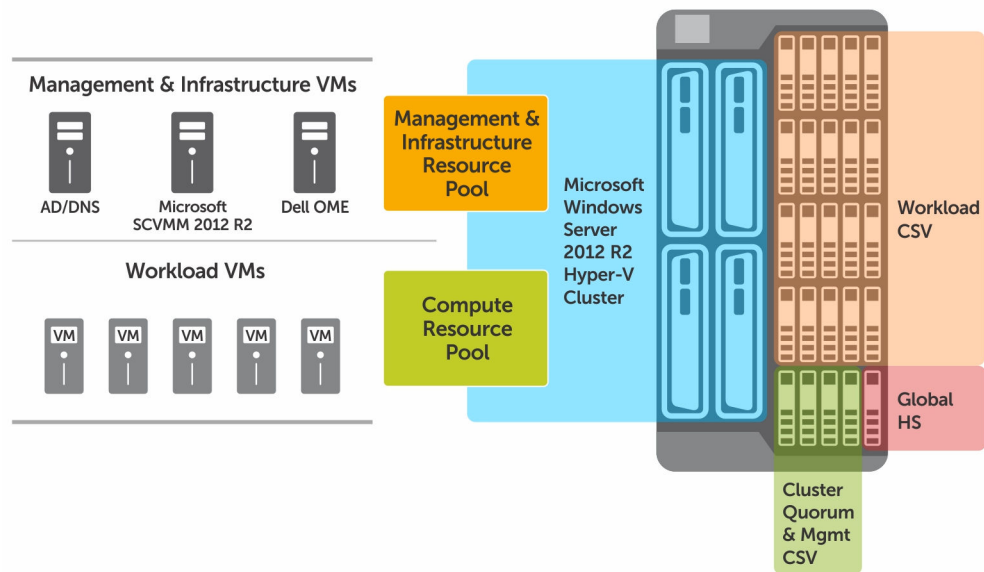

Figure 1. PowerEdge VRTX Hyper-V reference architecture



## Solution requirements

The following are the hardware and software requirements for deploying Windows Server 2012 R2 Hyper-V on the Dell PowerEdge VRTX chassis.

### Hardware requirements

The following table lists the hardware requirements:

**Table 2. Hardware requirements**

Components	Hardware Requirements
Chassis and Servers	Dell PowerEdge VRTX with the Dell PowerEdge M630 servers
Switches	Top-of-rack (ToR) switches in the customer environment for 10GbE LAN connectivity and Out-of-Band Management
Switch Module	Dell Networking R1-2210 10GbE switch module
On board Network Daughter Card	QLogic BCM 57810 10GbE Dual Port Mezzanine Card
Storage	PowerEdge VRTX Shared storage controller with 25 bay 2.5" SAS enclosures

### Software requirements

The following table lists the software requirements:

**Table 3. Software Requirements**

Components	Software Requirements
Hypervisor	Microsoft Windows Server 2012 R2 Hyper-V
Virtual Machine Management	Microsoft System Center 2012 R2 Virtual Machine Manager with Update Rollup 6
Network Drivers	QLogic BCM57810 network drivers Download from <a href="http://dell.com/support">dell.com/support</a>

Components	Software Requirements
Shared PERC Drivers	Dell Shared PERC8

## Firmware requirements

This solution is deployed using the firmware versions listed in the following table.

**Table 4. PowerEdge M630 servers**

Components	Version
BIOS	1.2.5
CPLD	1.0.5
iDRAC8 Enterprise	2.15.10.10
Lifecycle Controller (LC) 2	2.15.10.10
PERC H730 Mini	25.3.0.0016
BRCM 57810 NDC	7.12

**Table 5. VRTX chassis and switches**

Components	Version
CMC	2.04,A00
Dell Networking R1-2210 10GbE Switch Module	2.0.0.51

## Cabling requirements

The following figure shows the high-level design of the reference architecture:

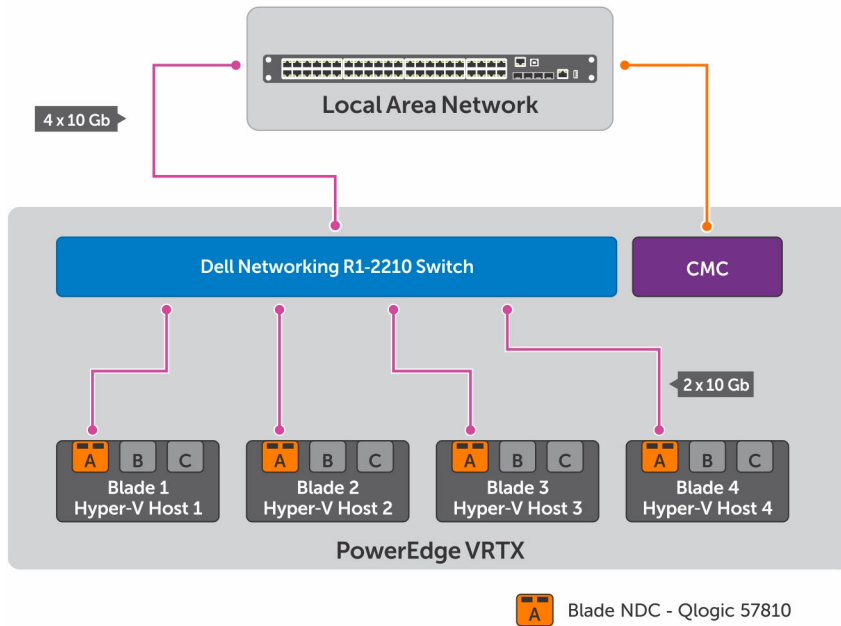

**Figure 2. Network architecture for VRTX Hyper-V deployment**

In the preceding design, each of the Dell Blade server LOMs (LAN On Motherboard) directly maps to Fabric A. The mezzanine cards on slot B and slot C are not used for the traditional I/O expansion. Instead, they are used for connecting to the PCIe infrastructure. The PowerEdge VRTX chassis is designed to use PCIe slots through two PCIe switches—one for Fabric B and one for Fabric C. Each PCIe switch ties into one of the two mezzanine cards on the server nodes to provide connectivity to the PCIe slot as mentioned in Table 6.

**NOTE:** The mezzanine cards on the slots B and C are not used for network traffic in this reference architecture. However, the mezzanine cards are required for connectivity to SPERC.

**Table 6. PCIe switch mappings**

PCIe switch	PCIe slot connectivity	Mezzanine slot
Fabric B PCIe Switch	PCIe slot 3, PCIe slot 6, PCIe slot 7, PCIe slot 8 and a Shared PowerEdge RAID Controller (SPERC)	Mezz B
Fabric C PCIe Switch	PCIe slot 1, PCIe slot 2, PCIe slot 4, PCIe slot 5	Mezz C

The SPERC is mapped to the server blades in the VRTX chassis through Fabric B and C PCIe switches. These PCIe switches are mapped to the server blades by using the mezzanine cards B and C.

The following figure illustrates how the fabrics are connected in the PowerEdge M630 server and the utilization of the I/O modules.

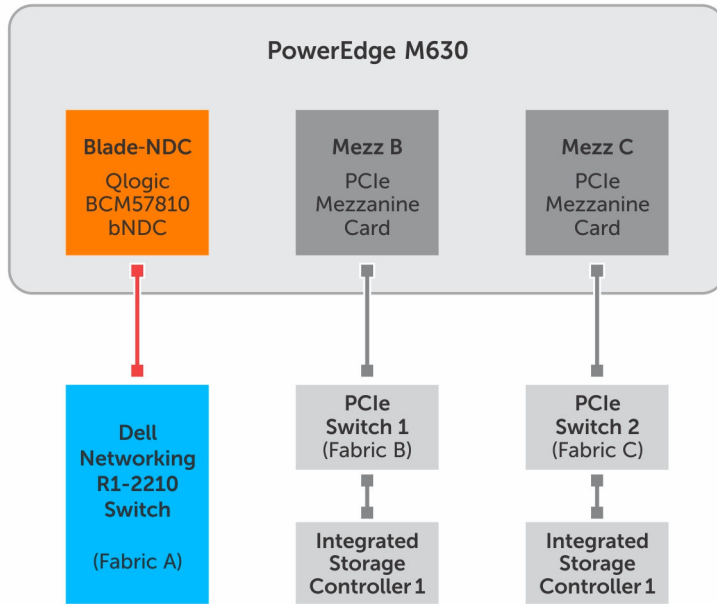

Figure 3. I/O connectivity of M630 on PowerEdge VRTX chassis

# Hyper-V on the Dell PowerEdge VRTX chassis— deployment workflow

This section outlines the complete deployment sequence of Hyper-V on the PowerEdge VRTX solution.

1. Complete the solution requirements. See [Solution requirements](#).
2. Complete the cabling. See [Cabling requirements](#).
3. Configure the following components:
  - Dell Networking R1-2210 10GbE switch module. See [Configuring Dell Networking R1-2210 switch module](#).
  - VRTX chassis and M630 servers. See [Configuring PowerEdge VRTX chassis CMC and PowerEdge M630 servers for OOB management](#).
  - VRTX Storage. See [Configuring the VRTX storage](#).
4. Configure Virtualization — Hyper-V
  - a. Install virtualization infrastructure. See [Installing virtualization infrastructure](#)
  - b. Configure virtual disk for OS deployment. See [Configuring RAID in the Dell PowerEdge M630](#).
  - c. Configure prerequisites to install Windows Server. See [Hyperv\\_ Configuring virtualization prerequisites to install Windows Server](#).
  - d. Install Windows Server 2012 R2 operating system in the Dell PowerEdge VRTX. See [Installing Windows Server 2012 R2 operating system in the Dell PowerEdge M630](#).
  - e. Enable Hyper-V and multipath feature on Windows Server 2012 R2. See [Enabling Hyper-V on Windows Server 2012 R2](#).
  - f. Set up NIC teaming on Windows Server 2012 R2. See [Setting up NIC teaming on Windows Server 2012 R2](#).
  - g. Configure network in Windows Server 2012 R2. See [Configuring network](#).
  - h. Add the Dell PowerEdge VRTX servers to the domain. See [Moving Dell PowerEdge M630 servers to the domain](#).
  - i. Configure vEthernet switch. See [Configuring vEthernet switch](#).
  - j. Assign the virtual disks. See [Assigning virtual disks](#).
  - k. Download and install the shared PERC driver. See [Installing the shared PERC driver](#).
  - l. Add MPIO settings. See

- [Adding MPIO settings.](#)
- m. Configure the registry settings. See [Configuring registry.](#)
  - n. Add volumes in the Dell PowerEdge M630 servers. See [Add volumes.](#)
  - o. Enable failover clustering on Windows Server 2012 R2. See [Enabling failover clustering on Windows Server 2012 R2.](#)
  - p. Create cluster. See [Creating clusters.](#)
5. Verify the deployment. See [Verifying the deployment.](#)

# Configuring components

Before you set up Windows Server 2012 R2 Hyper-V on the virtual infrastructure, you must set up and configure the following components:

1. Dell Networking R1-2210 10GbE switch module. See [Configuring Dell Networking R1-2210 switch module](#).
2. PowerEdge VRTX chassis and M630 servers. See [Configuring VRTX chassis CMC and M630 servers for OOB management](#).
3. Configure VRTX Storage. See [Configuring the VRTX storage](#).

## Configuring Dell Networking R1-2210 switch module

This section describes configuring the switch module R1-2210 by using CLI. To configure the switch module R1-2210, the following tasks are performed:

- Set the host name of the switch and credentials to access the switch.
- Configure the VLANs on the server and uplink ports.

The section also describes setting up an uplink port channel for external connectivity.

To configure the Dell Networking R1-2210 switch module, perform the following steps:

1. Access the switch console (CLI) of the R1-2210 switch module.  
To access the console, use SSH with the VRTX CMC console and type `connect switch`.
2. Configure the host name. **Syntax:** `hostname <name>`  

```
console#configure
console(config)#hostname R1-2210
console(config)#ex
```
3. Configure a system username and password to access the system remotely by using the following commands:  
**Syntax:** `username <username> password <password> privilege <privilege level>`  

```
R1-2210#
configure
username admin password Dell1234 priv 15
Exit
```
4. Configure the Management IP address by performing the following in the VRTX CMC GUI:
  - a. Log in to the CMC GUI by using the default user name `root` and password `calvin`.
  - b. In the left pane, click **Chassis Overview** → **I/O Module** → **10 GbE KR**, and then click the **Setup** tab.
  - c. In the **Setup** tab, assign IP to the R1-2210 switch and click **Apply**.
5. Configure SNMP using the following commands:  

```
R1-2210#
configure
```

```
snmp-server community public ro
exit
```

6. Configure Port channel on the external 10G interfaces:

```
R1-2210(config)#interface Port-Channel 1
R1-2210(config-if)#switchport mode trunk
R1-2210(config-if)#switchport trunk allowed vlan add 10,20,30,40
```

```
R1-2210(config)#interface range
TengigabitEthernet 0/1-4
R1-2210(config-if-range)#channel-group 1 mode auto
```

7. Configure the host interfaces by using the following commands:

```
console#configure
console(config)#interface range TengigabitEthernet1/1-4
console(config-if-range)#switchport mode trunk
console(config-if-range)#switchport trunk allowed vlan add 10,20,30,40
console(config-if-range)#spanning-tree portfast
```

8. Configure the VLANs by using the following commands:

```
R1-2210#configure
R1-2210(config)#vlan database
R1-2210(config-vlan)#vlan 10 name Management
R1-2210(config-vlan)#vlan 20 name Cluster
R1-2210(config-vlan)#vlan 30 name LiveMigration
R1-2210(config-vlan)#vlan 40 name VM
```

## Configuring PowerEdge VRTX chassis CMC and PowerEdge M630 servers for OOB management

After cabling the chassis to the network infrastructure, turn on the chassis and all the PowerEdge M630 servers.

1. Connect one end of the serial cable to the serial connector on the back of the PowerEdge VRTX chassis and the other end of the cable to the management station (Laptop) serial port.
2. By using a terminal emulation software, access the CMC console. In the console, configure the connection as follows:
  - **Baud rate** – 115200
  - **Port** – COM1
  - **Data** – 8 bit
  - **Parity** – None
  - **Stop** – 1 bit
  - **Hardware flow control** – Yes
  - **Software flow control** – No
3. Log in to the CMC using the default credentials. The default user name is `root` and the password is `calvin`.
4. Run the following command to set the management IP address for the VRTX chassis:

```
racadm setniccfg -s <IPv4 Address> <netmask> <IPv4 Gateway>
```

5. Run the following command to set the iDRAC management IP address for each of the PowerEdge M630 servers present in the chassis:

```
Racadm setniccfg -m server-1 -s <IPv4 Address> <netmask> <IPv4 Gateway>
Racadm setniccfg -m server-2 -s <IPv4 Address> <netmask> <IPv4 Gateway>
Racadm setniccfg -m server-3 -s <IPv4 Address> <netmask> <IPv4 Gateway>
Racadm setniccfg -m server-4 -s <IPv4 Address> <netmask> <IPv4 Gateway>
```



 **NOTE:** You can also configure the iDRAC using CMC GUI.

6. After setting up the management IP address for CMC and iDRAC for each server, run the following command to reset the CMC:

```
Racadm racreset
```

Open the CMC console using CMC IP and confirm that the iDRAC management IP addresses are set correctly for the PowerEdge M630 servers.

## Configuring BIOS on the PowerEdge M630 server

This section describes how to enable virtualization and hyper-threading (HT).

Perform the following tasks to configure BIOS on the PowerEdge M630 server:

1. Turn on or restart the server.
2. To enter **System Setup**, press F2 immediately after you see the following message:  
<F2>=System Setup
3. Ensure that the logical processor is enabled by performing the following steps:
  - a. On the **System Setup** page, click **System Setup Main Menu** → **System BIOS** → **Processor Settings**.
  - b. On the **Processor Settings** page, verify that **Logical Processor Settings** is set to **Enabled**.
4. Ensure that virtualization technology is enabled by performing the following steps:
  - a. On the **System Setup** page, click **System Setup Main Menu** → **System BIOS** → **Processor Settings**.
  - b. On the **Processor Settings** page, check that **Virtualization Technology** is set to **Enabled**.

## Configuring the VRTX storage

Complete the following tasks to configure the VRTX storage:

1. Assign Virtual Adapter to server slots. See [Assigning virtual adapters to server slots](#).
2. Create Virtual Disks. See [Creating virtual disks](#).
3. Initialize Virtual Disks. See [Initializing virtual disks](#).
4. Assign Global Hot Spare. See [Assigning global hot spares](#).

### Assigning virtual adapters to server slots

Perform the following steps to assign virtual adapters to server slots:

1. Log in to the CMC GUI by using the default user name `root` and password `calvin`.
2. In the left pane, click **Chassis Overview** → **Storage** → **Setup**.  
The Storage **Virtualization** page is displayed.
3. Under the **Virtual Adapter Mapped** section, map the virtual adapters 1 to 4 to the corresponding server slots as mentioned in the following table:

**Table 7. Assigning virtual adapters to virtual slots**

Virtual adapter	Server slot
Virtual Adapter 1	Slot 1
Virtual Adapter 2	Slot 2
Virtual Adapter 3	Slot 3
Virtual Adapter 4	Slot 4

- Under **Assignment Mode: Virtual Disks to Virtual Adapters** section, select **Multiple Assignment**. This mode allows a virtual disk to be assigned to multiple virtual adapters at a time.
- Click **Apply**.

## Creating virtual disks

RAID 10 provides redundancy, better performance, and is the best option for I/O intensive workloads. Microsoft recommends the usage of 64K block size for disks, VHD/VHDx files, and CSVs.

Perform the following steps to create a virtual disk:

- In the left pane, click **Chassis Overview** → **Storage** → **Virtual Disks** → **Create**.
- On the **Create Virtual Disk** page, under the **Settings** section, create virtual disks as mentioned in the following table:

**Table 8. Virtual disks**

Name	Capacity	Physical disks to be used	RAID level
VD1_Quorum	2 GB	1,2,3,4	10
VD2_VMVHDs	Select available space after creating VD1_Quorum volume.	1,2,3,4	10

- Under **Select Physical Disks**, select the physical disks 1, 2, 3, 4 on which the virtual disks will be created.
- Click **Apply**.

## Initializing virtual disks

To initialize virtual disks:

- In the left pane, click **Chassis Overview** → **Storage** → **Virtual Disks** → **Manage**.
- On the **Manage Virtual Disks** page, from the **Virtual Disk Actions** drop-down menu, select **Initialize:Fast**, and then click **Apply**.  
Wait until the initialization process completes as it will take some minutes to complete.

## Assigning global hot spares

To assign or unassign a global hot spare:

- In the left pane, click **Chassis Overview** → **Storage** → **Physical Disk** → **Setup**.

The **Setup Physical Disks** page is displayed.

2. Under the **Global Hotspares Assignment** section, from the **Hotspare Action** drop-down menu, select **Global Hotspare** for **Physical Disk 0.0.0**, and then click **Apply**.

# Configuring solution for virtualization – Windows Server 2012 R2 Hyper-V

## Installing virtualization infrastructure

To set up virtualization, perform the following tasks:

- [Configuring virtual disk for OS deployment in Dell PowerEdge M630 servers](#)
- [Configuring prerequisites to install Windows Server](#)
- [Installing Windows Server 2012 R2 operating system in the Dell PowerEdge VRTX](#)
- [Enabling Hyper-V and multipath features in Windows Server 2012 R2](#)
- [Setting up NIC teaming in Windows Server 2012 R2](#)

## Configuring virtual disk for OS deployment in Dell PowerEdge M630 servers

1. Log in to iDRAC and launch the virtual console.
2. From the menu, select **Power** → **Power on the system**.
3. In the message – You are about to execute a server control action. Are you sure you want to continue?, click **Yes**.
4. During system start, once you see this message press <CTRL> + <R> to Run configuration utility, press <CTRL> + <R> to run the RAID configuration utility.
5. In the configuration utility, select PERC H730 Mini and press **F2** to enable operations.
6. From the drop-down list, select **Create New VD**.
7. Set RAID Level to **RAID-1**, select physical disks, set the basic settings, use default virtual disk size, virtual disk name, and then click **OK**.



**NOTE:** Although an OS partition is not I/O intensive, the OS partition should still have hardware redundancy. Therefore, consider RAID 1 for OS partitions.

8. In the message – It is recommended that all newly created logical drives be initialized unless you are attempting to recreate a previous configuration and recover data as initialization is a destructive process. Are you sure you want to skip initialization?, click **OK**.

The virtual disk is created.

9. Exit setup.
10. Restart the server.

# Configuring prerequisites to install Windows Server

## Mapping to virtual disk

1. In the virtual console, select **Connect Virtual Media**, and then select **Map CD/DVD**.
2. In **Drive/Image File**, provide the drive location and click **Map Device**.

## Setting boot device and loading the OS executable files

1. In the virtual console, select **Next Boot**, and then select **Virtual CD/DVD/ISO**.
2. In the message - The selected device is set as the boot device for the next boot until another user changes the selected boot device. Therefore, it is recommended to reboot the server immediately after saving this selection. Click OK to save the selection., click **OK**.  
Virtual CD/DVD/ISO is set as the boot device.
3. Restart the server.

## Installing Windows Server 2012 R2 operating system in the Dell PowerEdge VRTX

1. Power on the server and press any key only after you see the message Booting from Virtual CD.  
Press any key to boot from CD or DVD.  
  
The Windows server setup is displayed.
2. Provide language preference, time and currency format, keyboard or input method, and then click **Next**.
3. In Windows Setup, click **Install now**.
4. Provide the product key and then click **Next**.
5. Select OS - Windows Server 2012 R2 Datacenter (Server with GUI) and then click **Next**.
6. In **License terms**, select **I accept the license terms** and then click **Next**.
7. In installation type, select **Custom: Install windows only (advanced)**.
8. Select **Drive0 Unallocated Space** and click **New** to create the partition and then click **Next** twice.  
In the message - To ensure that all Windows features work correctly, Windows might create additional partitions for system files, click **OK**.
9. Once the installation is complete, in **Setting page**, set the user name and password details.

## Enabling Hyper-V and multipath features in Windows Server 2012 R2

1. In **Server Manager**, on **Dashboard**, click **Manage** → **Add Roles and Features**.
2. In **Add Roles and Features Wizard**, click **Before you begin**, and then click **Next**.
3. In **Installation Type**, click **Role-based or feature-based Installation**, and then click **Next**.
4. In **Server Selection**, select **Select a server from the server pool** and in the server pool, select server and then click **Next**.

5. In **Server Roles**, select **Hyper-V** and then click **Next**.
6. In **Add Roles and Features Wizard**, select **Include management tools (if applicable)**, and then click **Add Features**.
7. In **Server Roles**, click **Hyper-V** and then click **Next**.
8. In **Features**, select **Multipath I/O** and then click **Next**.
9. In **Hyper-V**, click **Next**.
10. In **Virtual Switches**, click **Next**.
11. In **Migration**, click **Next**.
12. In **Default Stores**, keep default settings and then click **Next**.
13. In **Confirmation**, review the roles you have selected, select **Restart the destination server automatically if required**, and then click **Install**.
14. In **Results**, once the roles and features are installed and the server restarts, click **Close**.

## Setting up NIC teaming in Windows Server 2012 R2

1. In Server Manager, select **Local Server**.
2. In **Properties**, click NIC Teaming status – **Disabled**.
3. In **NIC Teaming**, from **TASKS**, select **New Team**.
4. In **New team**, provide team name, for example `ConvergedNet Team`, select the NICs that you want to include in the team, in **Additional properties**, set **Teaming mode** to **Switch Independent** and **Load balancing mode** to **Dynamic**, and then click **OK**.

 **NOTE:** The dynamic mode is a new feature of Windows Server 2012 R2. The load balancing algorithm balances traffic based on flowlets and can spread both inbound and outbound traffic. The Hyper-V port algorithm forces all VM traffic only through one physical NIC, whereas the dynamic mode spreads traffic across all the NICs, regardless of workload.

5. Check, if the NICs are active.

## Configuring network in Windows Server 2012 R2

This section describes the configuration of converged Hyper-V network for the Hyper-V hosts. This includes configuring a converged switch, VM network adapters, and Quality of Service (QoS) for the virtual networks.

The Hyper-V QoS in Windows Server 2012 R2 enables minimum bandwidth that guarantees a specified minimum bandwidth for a traffic flow. The minimum bandwidth percentage for each traffic flow is calculated based on the sum of all the assigned weights including the weight of the default flow.

The following table details the traffic types and the respective bandwidth weights.

**Table 9. Network QoS bandwidth allocation**

Traffic type	Minimum bandwidth weight
Management	5
Cluster / CSV	40
Live Migration	20
DefaultFlowMinimumBandwidthWeight	10

 **NOTE:** The bandwidth weights mentioned in the table are indicative and should be evaluated based on network requirements and applications running in your environment.

In the Dell PowerEdge VRTX server, start Windows PowerShell and run the following commands.

1. Create a new VM switch:

```
New-VMSwitch -AllowManagementOS 1 -Name ConvergedNetSwitch -  
MinimumBandwidthmode weight -Verbose  
NetAdapterName: ConvergedNet Team
```

2. Create VM network adapter for Cluster:

```
Add-VMNetworkAdapter -ManagementOS -SwitchName ConvergedNetSwitch -Name  
Cluster -Verbose
```

3. Create VM network adapter for Live Migration:

```
Add-VMNetworkAdapter -ManagementOS -SwitchName ConvergedNetSwitch -Name  
LiveMigration -Verbose
```

4. Set VLAN access properties for the Management Network Adapter:

```
Set-VMNetworkAdapterVlan -ManagementOS -VMNetworkAdapterName  
ConvergedNetSwitch -Access -VlanId 10
```

5. Set VLAN access properties for the Cluster Network Adapter:

```
Set-VMNetworkAdapterVlan -ManagementOS -VMNetworkAdapterName Cluster -Access  
-VlanId 20
```

6. Set VLAN access properties to LiveMigration:

```
Set-VMNetworkAdapterVlan -ManagementOS -VMNetworkAdapterName LiveMigration -  
Access -VlanId 30
```

7. Set minimum bandwidth reservation for Management Network Adapter:

```
Set-VMNetworkAdapter -ManagementOS -Name ConvergedNetSwitch -  
MinimumBandwidthWeight 5
```

8. Set minimum bandwidth reservation for Cluster network adapter:

```
Set-VMNetworkAdapter -ManagementOS -Name Cluster -MinimumBandwidthWeight 40
```

9. Set minimum bandwidth reservation for Live Migration network adapter:

```
Set-VMNetworkAdapter -ManagementOS -Name LiveMigration -  
MinimumBandwidthWeight 20
```

 **NOTE:** Under Network Connections, view vEthernet (ConvergedNetSwitch) and adapters for cluster and live migration.

## Sample naming and IP addressing scheme

The IP addressing provides the requirement to support PowerEdge VRTX chassis solution. For more information, see [Appendix B](#).

## Configuring vEthernet switch in Windows Server 2012 R2

1. In **Network Connections**, right-click **vEthernet (ConvergedNetSwitch)** and in the drop-down list, select **Properties**.
2. In **vEthernet (ConvergedNetSwitch) Properties**, configure IPV4 protocol properties, include IP address and DNS server details and then click **OK**.

3. Test the network connection: ping the VLAN 10 network.

## Adding the Dell PowerEdge VRTX servers to the domain

1. In the Dell PowerEdge VRTX server, in **System Properties**, on the **Computer Name** tab, click **Change**.
2. In **Computer Name/Domain Changes**, provide a name to the server. For example, `HyperVH3`.
3. Under **Member of**, select **Domain** and type domain name, for example `hyperv.lab`, and then click **OK**.
4. In **Windows Security**, provide domain administrator's user name and password, and then click **OK**.  
Once the PowerEdge VRTX server is added to the domain, a welcome message is displayed.
5. In the welcome message, click **OK** and restart the server.





## Assigning virtual disks

To set up the VD assignment mode, ensure that the physical disk drives are installed and the virtual disks are created.

To assign modes to the VDs, perform the following steps:

1. In the left pane, click **Chassis Overview** → **Storage** → **Virtual Disks** → **Assign**.
2. On the **Assign Virtual Disks** page, for all the **Virtual Adapters**, provide full access rights by selecting **Full Access** from the drop-down list.
3. Click **Apply**.

## Installing the shared PERC driver

1. To download the PERC driver, perform the following steps:
  - a. Go to **Dell.com/drivers**.
  - b. In the Product Selection section, enter the Service Tag of your system in the **Service Tag** or **Express Service Code** field.
    -  **NOTE:** If you do not have the Service Tag, select **Automatically detect my Service Tag** for me to allow the system to automatically detect your Service Tag, or select **Choose from a list of all Dell products** to select your product from the Product Selection page.
    -  **NOTE:** To download the latest firmware and driver for components inside the PowerEdge VRTX chassis (for example Shared PERC 8 firmware and driver), enter the Service Tag or the model number of the PowerEdge VRTX chassis.
  - c. Select the Operating System, Category, Release Date, and Importance from the respective drop-down lists.
  - d. The drivers that are applicable to your selection are displayed.
  - e. Download the Shared PERC 8 to a local drive, USB drive, CD, or DVD.
2. To install Windows drivers for Shared PERC 8, perform the following steps:
  -  **NOTE:** PERC H330/H730/H730P/H830 controllers use the same driver as Shared PERC 8 and do not require separate driver installations.
  -  **NOTE:** For more information, see the *PowerEdge VRTX Storage Subsystem Compatibility Matrix* at **Dell.com/support/home**.
  -  **NOTE:** Close all applications on your system before you install the driver.



- a. Double-click the downloaded file and follow the steps in the wizard.
- b. Click **Next** and continue with the installation steps in the wizard.
- c. Click **Finish** to exit the wizard.

 **NOTE:** Dell provides the Dell Update Package (DUP) to update drivers on systems running Windows Server 2012/2012 R2 or Windows Server 2008/2008 R2 operating systems. DUP is an executable application that updates drivers for specific devices. DUP supports command line interface and silent execution. For more information, see [Dell.com/support](http://Dell.com/support).

The installation of the shared PERC driver on all the hosts is now complete.

## Adding MPIO settings in Windows Server 2012 R2

1. Select the server node and open **Server Manager**.
2. In **Server Manager**, click **Tools** → **MPIO**.
3. In **MPIO Properties**, click the **Discover Multi-Paths** tab, and then select **Dell SharedPERC8**.
4. Click **Add** and then reboot the server.

After rebooting the server, the MPIO installation is finalized.

## Configuring registry

The cluster validation utility might fail if the shared storage type used by the system is direct attached or clustered RAID controllers. To resolve this problem, add the following registry key.

 **NOTE:** For more information, refer the Windows Knowledge Base link available at, [HTTPS://SUPPORT.MICROSOFT.COM/EN-US/KB/2839292](https://support.microsoft.com/en-us/kb/2839292).

 **CAUTION:** Incorrectly editing the registry may severely damage your system. Before making changes to the registry, you should back up any valued data on your computer.

1. Press **Win** [Windows key] + **R** on your keyboard.
2. In the dialog box that is displayed, type `regedit.exe` and click **OK**.
3. Click **Yes** when the Windows UAC prompt appears.
4. Navigate to `Computer\HKEY_LOCAL_MACHINE\SYSTEM\CurrentControlSet\Service\CluDisk\Parameters` folder.
5. On the **Edit** menu, point to **New**, and then click **DWORD (32-bit) Value**.
6. Type `AllowBusTypeRAID` in the **name** field for the new DWORD, set the **Value Data** to **1**, in the **Base** selection options, select **Decimal** and then press **Ok**.
7. Close the Registry Editor.

## Adding volumes in the Dell PowerEdge M630 servers

1. Log in to the Dell PowerEdge VRTX server, and in **Run**, type `diskmgmt.msc`.
2. In **Disk Management**, perform the following steps:
  - a. Right-click new disk, and set the value of disk to **Online**.
  - b. Right-click disk and initialize disk.
  - c. Right-click disk and select **New Simple Volume**.
3. In **New Simple Volume Wizard**, click **Next**.
4. In **Specify volume size in MB**, use the default disk size, and then click **Next**.
5. In **Assign Driver Letter or Path**, select **Do not assign a driver letter or driver path**, and then click **Next**.

6. In **Format Partition**, select **Format this volume with the following settings:** and set **File system** to **NTFS**, **Allocation unit size** to **64kb**, **Volume label** to **Quorum**, select **perform a quick format** and then click **Next**.
7. In **Completing the New Simple Volume Wizard**, click **Finish**.
8. Repeat steps 1 – 7 to create the second volume for storing the VHD files of the virtual machines.

## Enabling failover clustering in Windows Server 2012 R2

1. In Server Manager, select **Manage**, and then select **Add Roles and Features**.
2. In **Add Roles and Features Wizard**, In **Before you begin**, select **Next**.
3. In **Installation Type**, select **Role-based or feature-based Installation**, and then click **Next**.
4. In **Server Selection**, select **Select a server from the server pool** and in the server pool, select server and then click **Next**.
5. In **Server Roles**, click **Next**.
6. In **Features**, select **Failover Clustering** and then click **Next**.
7. In **Add Roles and Features Wizard** pop-up, add features that are required for failover clustering, select **Include management tools (if applicable)**, and then click **Add Features**.
8. In **Features**, click **Next**.
9. In **Confirmation**, review the roles you have selected, select **Restart the destination server automatically if required**, and then click **Install**.
10. In **Results**, once the **Failover Clustering** role is installed, click **Close**.

 **NOTE:** Repeat the preceding tasks for the remaining Hyper-V hosts.

## Creating cluster

1. [Validating configuration](#)
2. [Creating a Hyper-V host cluster in VMM](#)

### Validating configuration

1. In **Failover Cluster Manager**, select **Validate Configuration**.
2. In **Validate a Configuration Wizard**, do the following:
  - a. In **Before you Begin**, click **Next**.
  - b. In **Select Servers**, add all the cluster nodes and then click **Next**.
  - c. In **Testing Options**, select **Run all tests (recommended)**.
  - d. In **Confirmation**, click **Next**.
  - e. In **Failover Cluster Validation Report**, clear **Create the cluster now using the validated nodes**, to view report, click **View Report**, and then click **Finish**.

### Creating a Hyper-V host cluster in VMM

1. Before you begin, create a host group in VMM. See [Creating host groups in VMM](#).
2. Create a Hyper-V host cluster in VMM. See [Creating a Hyper-V host cluster in VMM](#).

### Creating host groups in VMM

To configure host groups in VMM, perform the following steps:

1. Create host group structure in VMM:

- a. Open the **Fabric** workspace
- b. In the **Fabric** pane, expand **Servers**, and then do either of the following:
  - Right-click **All Hosts**, and then click **Create Host Group**.
  - Click **All Hosts**. On the **Folder** tab, in the **Create** group, click **Create Host Group**.

VMM creates a new host group that is named **New host group** with the host group name highlighted.

- c. Type a new name, and then press **Enter**.
2. Configure host group properties in VMM.
  - a. In **Fabric**, expand **Servers**, **All Hosts**, and then click the host group that you want to configure.
  - b. On the **Folder** tab, in the **Properties** group, click **Properties**.
  - c. Configure any of the following settings:

**Table 10. Host groups settings**

Tab	Settings
<b>General</b>	Configure the host group name, location, description, and allow unencrypted BITS file transfers.
<b>Placement Rules</b>	VMM automatically selects the ideal host to deploy virtual machines. However, you can specify placement rules. By default, a host group uses the placement settings from the parent host group.

### Creating a Hyper-V host cluster in VMM



1. In VMM, select **Fabric** → **Servers**.
2. On the **Home** tab, in **Create group**, click **Create**, and then click **Hyper-V Cluster**.
3. In **Cluster Wizard**, on the **General** tab, provide cluster name and administrator user credentials, and then click **Next**.
4. In **Nodes**, perform the following steps and then click **Next**:
  - a. In **Host group**, select the host group that contains the Hyper-V hosts that you want to cluster.
  - b. In **Available hosts**, select the Hyper-V host that you want to cluster and then click **Add**.  
The hosts that you have added are moved to **Hosts to cluster**.
  - c. (Optional) Select **Skip cluster validation tests**.
5. In **Storage**, select the disks you want to cluster.
6. In **Virtual Switches**, click **Next**.
7. In **Summary**, confirm settings and then click **Finish**.
8. When the job is complete, verify the cluster status.

### Configuring Cluster Network

The following table shows the recommended settings for each type of network traffic. Configure these settings using Failover Cluster Manager.

**Table 11. Cluster Network Configuration**

Network Type	Recommended Settings
Management	Select the following check boxes.

Network Type	Recommended Settings
Cluster	<ul style="list-style-type: none"> <li>• <b>Allow cluster network communication on this network</b></li> <li>• <b>Allow clients to connect through this network</b></li> </ul> <p>Allow cluster network communication on this network.</p> <p> <b>NOTE:</b> Clear the <b>Allow clients to connect through this network</b> check box.</p>
Live Migration	<p>Allow cluster network communication on this network.</p> <p> <b>NOTE:</b> Clear the <b>Allow clients to connect through this network</b> check box.</p>

To configure Live Migration network settings using Failover Cluster Manager:

 **NOTE:** To configure the Live Migration network settings using SCVMM, in the SCVMM console, navigate to **Host Properties** → **Migration Settings**.

1. In the Failover Cluster Manager, right-click on the **Networks** in the left pane, and select **Live Migration Settings**.
2. In the **Live Migration Settings** dialog box, ensure that you select the correct network for Live Migration Traffic.

## Verifying the deployment

Once the deployment is complete, you may follow these steps to verify the solution:

1. Create VMs.
2. Migrate VMs across the cluster and check if the migration is progressing without any interruption.
3. Shut down one of the hosts and check if the VMs located on that host are migrating within the cluster.

## Appendix A

- Support.dell.com is focused on meeting customer requirements with proven services.
- [DellTechCenter.com](http://DellTechCenter.com) is an IT Community where you can connect with Dell customers and Dell employees for the purpose of sharing knowledge, best practices and information about Dell products and installations.
- Before you begin deploying the solution, read the *Microsoft Windows Server 2012 R2 Hyper-V on Dell PowerEdge VRTX Reference Architecture* document available at:

[http://en.community.dell.com/techcenter/extras/m/white\\_papers/20441317](http://en.community.dell.com/techcenter/extras/m/white_papers/20441317)

- Prerequisites for creating Hyper-V clusters: Complete all the prerequisites required for creating hyper-v clusters in VMM, for more information, see Microsoft documentation at <https://technet.microsoft.com/en-us/library/gg610630.aspx>.

## Appendix B

The following table represents an example of the PowerEdge VRTX chassis cluster along with the top-of-rack switches used in the solution:

Device name	OOB management	Hostname	Cluster IP	Live Migration IP
Dell Networking R1-2210 10GbE Switch Module	192.168.10.100	R1-2210		
VRTX CMC	192.168.10.10			
Compute nodes	192.168.10.11	HYPVN01	192.168.10.181	192.168.20.181
	192.168.10.12	HYPVN02	192.168.10.182	192.168.20.182
	192.168.10.13	HYPVN03	192.168.10.183	192.168.20.183
	192.168.10.14	HYPVN04	192.168.10.184	192.168.20.184