



Best Practices for Mixed Speed Devices within a 10 Gb EqualLogic Storage Area Network Using PowerConnect 8100 Series Switches

A Dell EqualLogic Best Practices Technical White Paper

Storage Infrastructure and Solutions Engineering
Dell Product Group
February 2013

This document has been archived and will no longer be maintained or updated. For more information go to the [Storage Solutions Technical Documents page on Dell TechCenter](#) or contact support.

© 2012 Dell Inc. All rights reserved. Reproduction of this material in any manner whatsoever without the express written permission of Dell Inc. is strictly forbidden. For more information, contact Dell.
Dell, the DELL logo, PowerConnect™, EqualLogic™, PowerEdge™, and PowerVault™ are trademarks of Dell Inc. in the U.S. and worldwide. All trademarks and registered trademarks mentioned herein are the property of their respective owners.



Table of contents

Acknowledgements.....	4
Feedback	4
Executive Summary	4
1 Introduction.....	5
1.1 Audience.....	5
1.2 Terminology.....	5
2 Product overview.....	6
3 Test methodology	7
4 Test setup and configuration.....	8
4.1 1 Gb environment (baseline)	9
4.2 1 Gb components with a 10 Gb switch infrastructure	10
4.3 1 Gb and 10 Gb components with a 10 Gb switch infrastructure.....	11
4.4 10 Gb environment (baseline).....	12
5 Results and analysis.....	13
6 Best practice recommendations.....	16
7 Conclusion.....	17
A Solution infrastructure details.....	18
B VDbench parameters	22
Additional resources.....	25



Acknowledgements

This whitepaper was produced by the PG Storage Infrastructure and Solutions of Dell Inc.

The team that created this whitepaper:

Ron Bellomio, Guy Westbrook, and Camille Daily

Feedback

We encourage readers of this publication to provide feedback on the quality and usefulness of this information by sending an email to SISfeedback@Dell.com.



SISfeedback@Dell.com

Executive Summary

In an effort to incrementally upgrade a SAN from a 1 Gb environment to a 10 Gb environment one can utilize the auto-negotiable 1G bE/10 GbE ports on a 10 Gb Ethernet switch to aid in the transition from 1 Gb to 10 Gb. A 1 Gb environment with the Dell™ PowerConnect™ 8164 shows no performance degradation when compared to a pure 1 Gb environment using a standard 1 Gb Ethernet switch such as the PowerConnect 7048. In addition, when running a mixed speed environment utilizing both the 1 Gb and 10 Gb devices, switch performance is within the expected range.



1 Introduction

With the growth of 10 Gb Ethernet, many Dell™ EqualLogic™ customers are transitioning from pure 1 GbE to pure 10 GbE environments. To complete this transition, new switches, storage arrays, and host Network Interface Cards (NICs) are required. In some deployments it is not feasible to convert all components from 1 Gb to 10 Gb at the same time.

This white paper discusses how the added complexity of a mixed speed design affects the performance characteristics of the Storage Area Network (SAN) solution, based on testing and evaluating workload data run in a pure 1 GbE environment as well as a mixed environment and a pure 10 GbE environment. It also provides the reader with a recommendation for using 1 Gb and 10 Gb devices in a single 10 Gb SAN fabric, as well as instructions for how to use the PowerConnect 8100 Series switches in a mixed-speed EqualLogic SAN.

1.1 Audience

This technical white paper is intended for storage administrators, SAN/NAS system designers, storage consultants, or anyone who is tasked with integrating a 1 GbE and 10 GbE solution with EqualLogic PS Series storage for use in a production storage area network. It is assumed that readers have experience in designing and/or administering a shared storage solution.

1.2 Terminology

This section defines terms that are commonly used in this paper and the context in which they are used.

CAT6 – Category 6 is a cabling standard for Ethernet networks. CAT6 is suitable for use with 1 Gb or 10 Gb Ethernet network devices and is recommended for use with EqualLogic SANs.

Host/port ratio – The ratio of the total number of host network interfaces connected to the SAN divided by the total number of active PS Series array member network interfaces connected to the SAN. A ratio of 1:1 is ideal for optimal SAN performance, but higher port ratios are acceptable in specific cases. The host to port ratio can negatively affect performance in a SAN when oversubscription occurs.

LAG – A link aggregation group (LAG) in which multiple switch ports are configured to act as a single high-bandwidth connection to another switch. Unlike a stack, each individual switch must still be administered separately and function as such.

Stack – An administrative grouping of switches that enables the management and functioning of multiple switches as if they were one single switch. The switch stack connections also serve as high-bandwidth interconnects.

TOR switch – A top of rack (TOR) switch.

Uplink – A link that connects the blade IOM switch tier to the TOR switch tier. An uplink can be a stack or a LAG. Its bandwidth must accommodate the expected throughput between host ports and storage ports on the SAN.



2 Product overview

The 10 GbE switch used in the tests for this paper is the PowerConnect 8164. The 8100 Series switches are stackable Layer 2 and Layer 3 switches that extend the PowerConnect LAN switching product range.

These switches include the following features:

- 1U form factor, rack-mountable chassis design.
- Support for all data communication requirements for a multilayer switch, including Layer 2 switching, IPv4 routing, IPv6 routing, IP multicast, quality of service, security, and system management features.
- High availability with hot swappable stack members.

Each of the PowerConnect 8100 Series switches has 24 or 48 ports of 10 Gb Ethernet in 10 GBase-T or SFP+ with redundant power supplies to provide high performance and high availability. PowerConnect 8100 Series switches can be stacked with other PowerConnect switches of the same model number using the 10 G SFP+ or QSFP fiber ports.



3 Test methodology

The test cases used in this paper were designed to test the ability and performance of the transition from a purely 1 GbE environment to a purely 10 GbE environment. The same workloads were run in all four test configurations to ensure that the data could be compared directly without introducing additional variables beyond the transition from a 1 Gb infrastructure to a 10 Gb infrastructure.

In order to determine the relative performance of each SAN design the performance tool vdbench was used to capture throughput values at four distinct I/O workloads. Vdbench is “a disk and tape I/O workload generator for verifying data integrity and measuring performance of direct attached and network connected storage.” (<http://sourceforge.net/projects/vdbench/>)

Note: All EqualLogic SAN best practices, such as enabling flow control and Jumbo frames, were implemented.

See [Appendix A](#) for details about the hardware and software infrastructure.

See [Appendix B](#) for a list of vdbench parameters.

The following four vdbench workloads were defined:

- Test case 1
 - All hosts - 8K random 67% read (IOPS, throughput, response time)
- Test case 2
 - All hosts - 256K sequential read (IOPS, throughput, response time)
- Test case 3
 - All hosts - 256K sequential write (IOPS, throughput, response time)
- Test case 4 (mixed workload)
 - 50% hosts - 8K random 67% read (IOPS, throughput, response time)
 - 25% hosts - 256K sequential read (IOPS, throughput, response time)
 - 25% hosts - 256K sequential write (IOPS, throughput, response time)

Each vdbench workload was run for three hours and the I/O rate was not capped (the vdbench “iorate” parameter was set to “max”). The throughput values used in the relative performance graphs are the sums of the values reported by all of the hosts combined.



4 Test setup and configuration

This section describes the setup and configuration for each test configuration. There were four configurations which tested the transition from a pure 1 Gb environment to a pure 10 Gb environment.

Note: In all tests and configurations, DCB was disabled because it is not within the scope of this paper.

First test configuration: 1 Gb environment (baseline)

Test configuration one was a pure 1 Gb environment. Hosts, arrays, and switches were all 1 Gb. The arrays were configured into a single pool of four arrays. This test was the baseline for the 1 Gb performance which was used to compare with test configurations two through four.

Second test configuration: 1 Gb components with a 10 Gb switch infrastructure

Test configuration two was the same environment as test configuration one with the exception of the switch. The first step of an infrastructure upgrade is to upgrade the switch. The 1 Gb switch was replaced by a 10 Gb (10 GBASE-T) switch with dual speed and auto-negotiable 1 GbE/10 GbE ports which allowed continued 1 Gb connections on the SAN with a switch capable of running 10 Gb. The arrays were configured into a single pool of 4 arrays. The results of this test configuration were compared to those in the first test configuration (refer to [Section 5](#)) to ensure that the 1 Gb performance was not degraded when using the dual speed, auto-negotiable 1 GbE/10 GbE ports on the 10 Gb switch.

Third test configuration: 1 Gb and 10 Gb components with a 10 Gb switch infrastructure

In test configuration three, 1 Gb and 10 Gb devices were mixed in the same fabric although the 1Gb initiators were only used to access the 1Gb arrays and the 10Gb initiators were used only to access the 10 Gb arrays. This was the next logical step to upgrade the infrastructure when adding 10 Gb devices (hosts and arrays) to the existing 1 Gb infrastructure. Testing in this configuration determined if running 1 Gb and 10 Gb speeds on the same switch would have an effect on each other. Within the same EQL group, the 1 Gb and 10 Gb arrays were put into separate pools of four arrays each. Identical workloads were run on both the 1 Gb and 10 Gb devices at the same time. The 1 Gb performance data was compared to the 1 Gb baseline data in test configuration one, and the 10 Gb performance data was compared to the 10 Gb baseline data in test configuration four. By comparing the data from test configuration three to the baseline data, we see that running 1 Gb and 10 Gb devices together does not have an effect on the performance.

Fourth test configuration: 10 Gb environment (baseline)

Test configuration four, and the final step of the infrastructure upgrade, involved removing the 1 Gb devices and finishing in an environment running only 10 Gb devices. The arrays were configured into a single pool of four arrays. The testing in this configuration involved the 10 Gb performance baseline which was used to compare to the test results in test configuration three.



4.1 1 Gb environment (baseline)

This section describes the configuration used for the pure 1 GbE environment illustrated in Figure 1.

- Eight PowerEdge R610 servers
 - Windows Server 2008 R2 SP1
 - One 1 GbE Broadcom NIC per host (two active 1 GbE ports on the SAN)
- Four EqualLogic PS6100XV arrays
 - Four active 1 GbE storage controller ports (four active 1 GbE ports on the SAN)
- Two PowerConnect 7048R switches
 - Stack mode
- One pool of four arrays
- Four iSCSI volumes dedicated to each host

Note: A host to storage port ratio of 1:1 is maintained (16 host ports: 16 array ports).

The two 7048R switches were stacked and the entire configuration is cabled using EqualLogic best practices (refer to the *EqualLogic Configuration Guide* at <http://en.community.dell.com/techcenter/storage/w/wiki/2639.equallogic-configuration-guide.aspx>). Refer to [Appendix A](#), titled "Solution infrastructure details" for the hardware specifications of the servers and arrays.

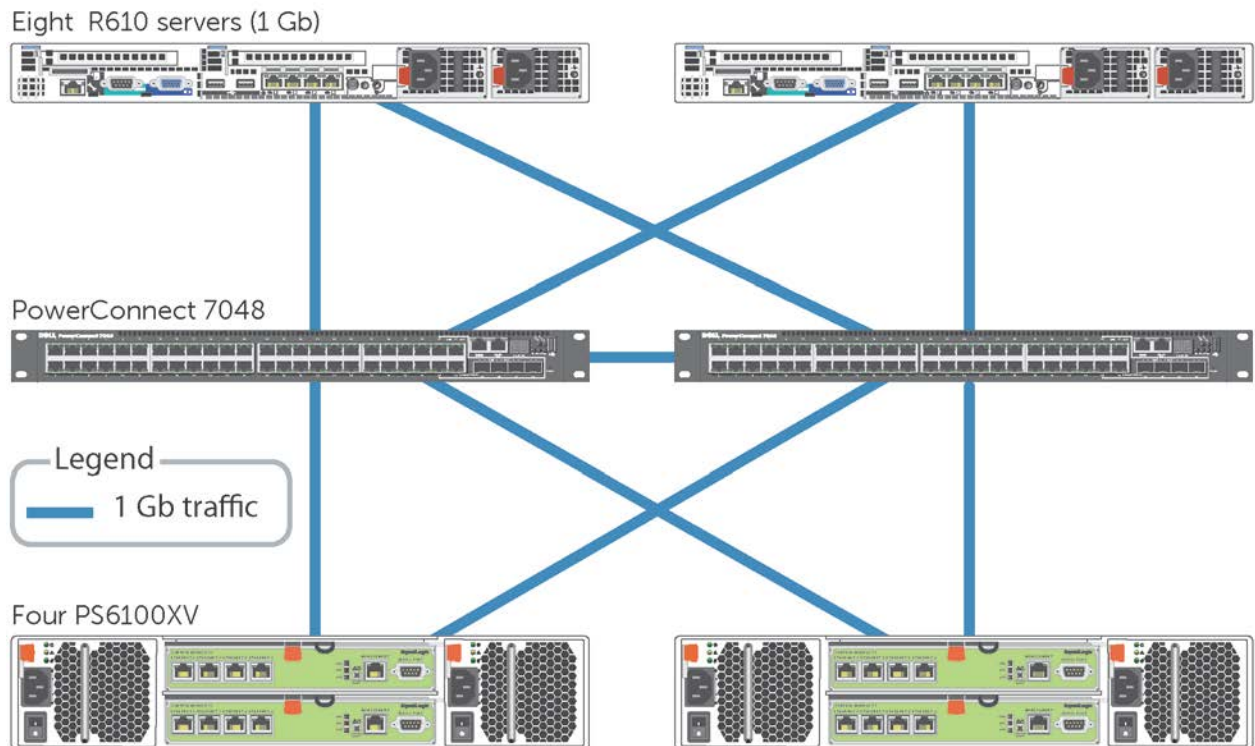

Figure 1 Test configuration 1

4.2 1 Gb components with a 10 Gb switch infrastructure

This section describes the configuration for the second test configuration consisting of 1 GbE hosts, 1 GbE arrays, and utilizing a 10 GbE switch as shown in Figure 2.

- Eight PowerEdge R610 servers
 - Windows Server 2008 R2 SP1
 - One 1 GbE Broadcom NIC per host (2 active 1GbE ports on the SAN)
- Four EqualLogic PS6100XV arrays
 - Four active 1 GbE storage controller ports (four active 1 GbE ports on the SAN)
- Two PowerConnect 8164 switches
 - LACP
- One pool of four arrays
- Four iSCSI volumes dedicated to each host

Note: A host to storage port ratio of 1:1 is maintained (16 host ports: 16 array ports).

The two 8164 switches are in a LAG and the entire configuration is cabled using EqualLogic best practices. Hardware specifications of the servers and arrays can be found in [Appendix A](#), titled "Solution infrastructure details".

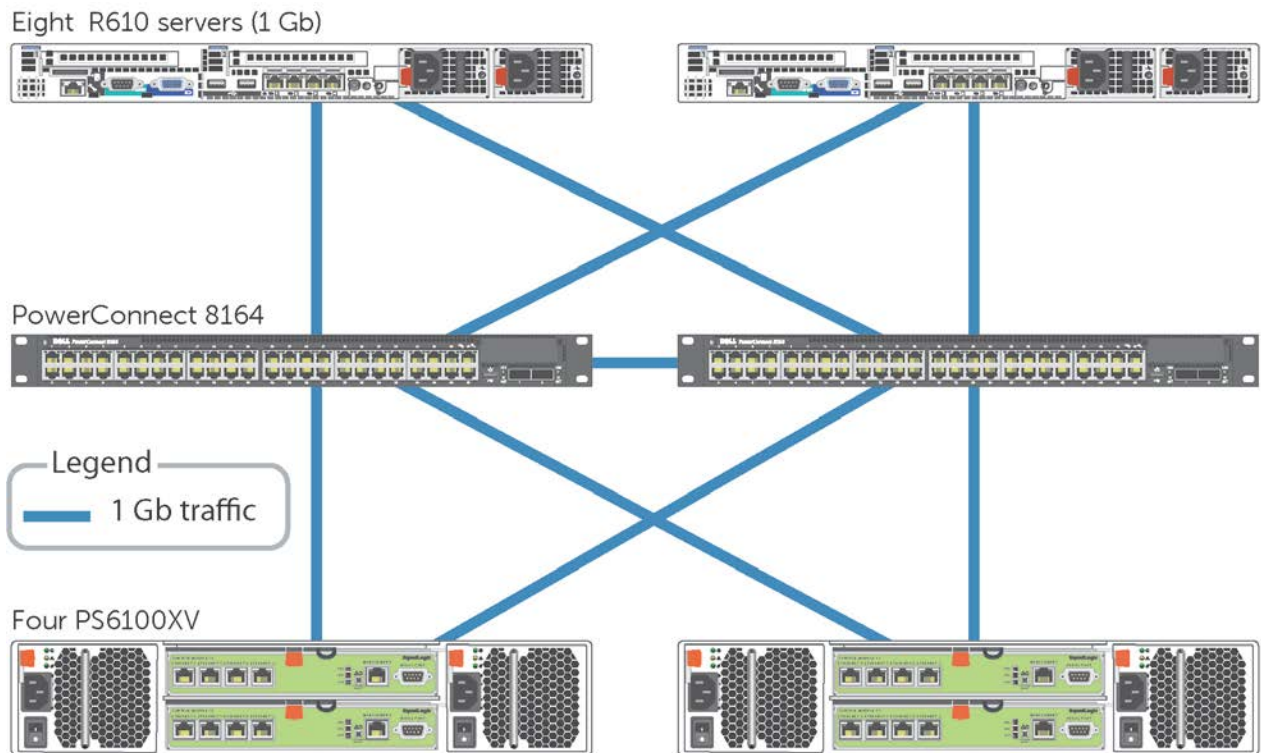

Figure 2 Test Configuration 2

4.3 1 Gb and 10 Gb components with a 10 Gb switch infrastructure

This section describes the configuration used for Test configuration 3 which includes 1 GbE and 10 GbE hosts and arrays utilizing a 10 GbE switch as illustrated in Figure 3.

- Ten PowerEdge R610 servers (eight for 1 Gb, two for 10 Gb)
 - Windows Server 2008 R2 SP1
 - One 1 GbE Broadcom NIC per 1 Gb host (two active 1 GbE ports on the SAN)
 - One 10 GbE Intel X540 NIC per 10 Gb host (two active 1 GbE ports on the SAN)
- Four EqualLogic PS6100XV (1 Gb) arrays
 - Four active 1 GbE storage controller ports (four active 1 GbE ports on the SAN)
- Four EqualLogic PS6110XV (10 Gb) arrays
 - one active 10GBASE-T storage controller port (one active 10 GbE port on the SAN)
- Two PowerConnect 8164 switches
 - LACP
- One pool of four arrays for 1 GbE
- One pool of four arrays for 10 GbE
- Four iSCSI volumes dedicated to each host (1 GbE)
- 16 iSCSI volumes dedicated to each host (10 GbE)

Note: A host to storage port ratio of 1:1 is maintained (16 host ports: 16 array ports for 1 Gb and four host ports: four array ports for 10 Gb).

The two 8164 switches are in a LAG and the entire configuration is cabled using EqualLogic best practices. Hardware specifications of the servers and arrays are in [Appendix A](#), titled, "Solution infrastructure details".

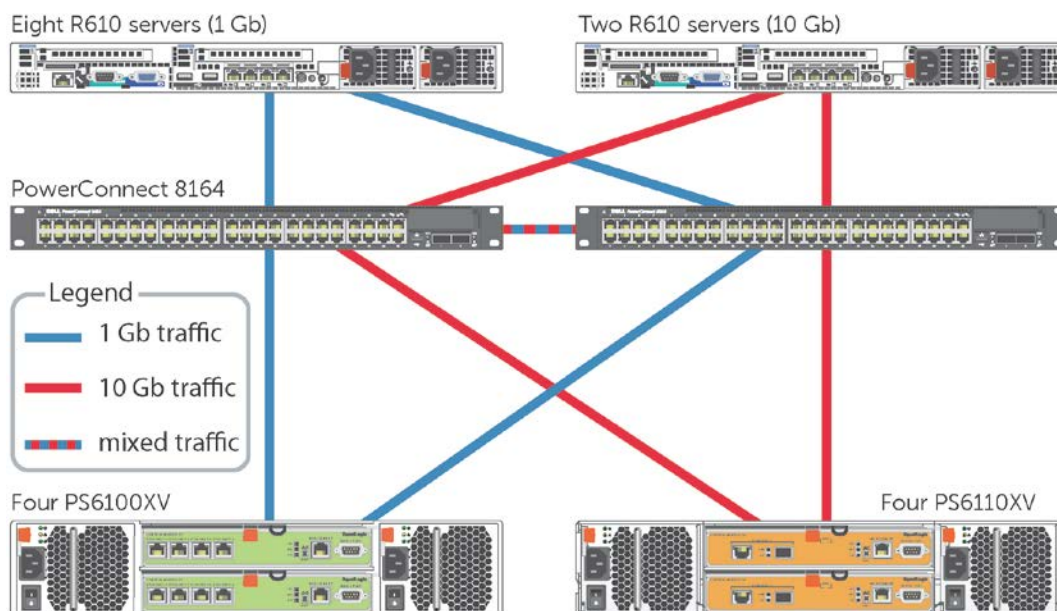

Figure 3 Test configuration 3



4.4 10 Gb environment (baseline)

This section will describe the configuration used for Test configuration 4 which uses a pure 10 GbE environment as illustrated in Figure 4.

- Two PowerEdge R610 servers
 - Windows Server 2008 R2 SP1
 - One 10 GbE Intel X540 NIC per 10 Gb host (two active 10 GbE ports on the SAN)
- Four EqualLogic PS6110XV (10 Gb) arrays
 - One active 10GBASE-T storage controller port (one active 10 GbE port on the SAN)
- Two PowerConnect 8164 switches
 - LACP
- One pool of four arrays
- Four iSCSI volumes dedicated to each host (1 GbE)

Note: A host to storage port ratio of 1:1 is maintained (4 host ports: 2 array ports).

The two 8164 switches are in a LAG and the entire configuration is cabled using EqualLogic best practices. Hardware specifications of the servers and arrays is in [Appendix A](#), titled "Solution infrastructure details".

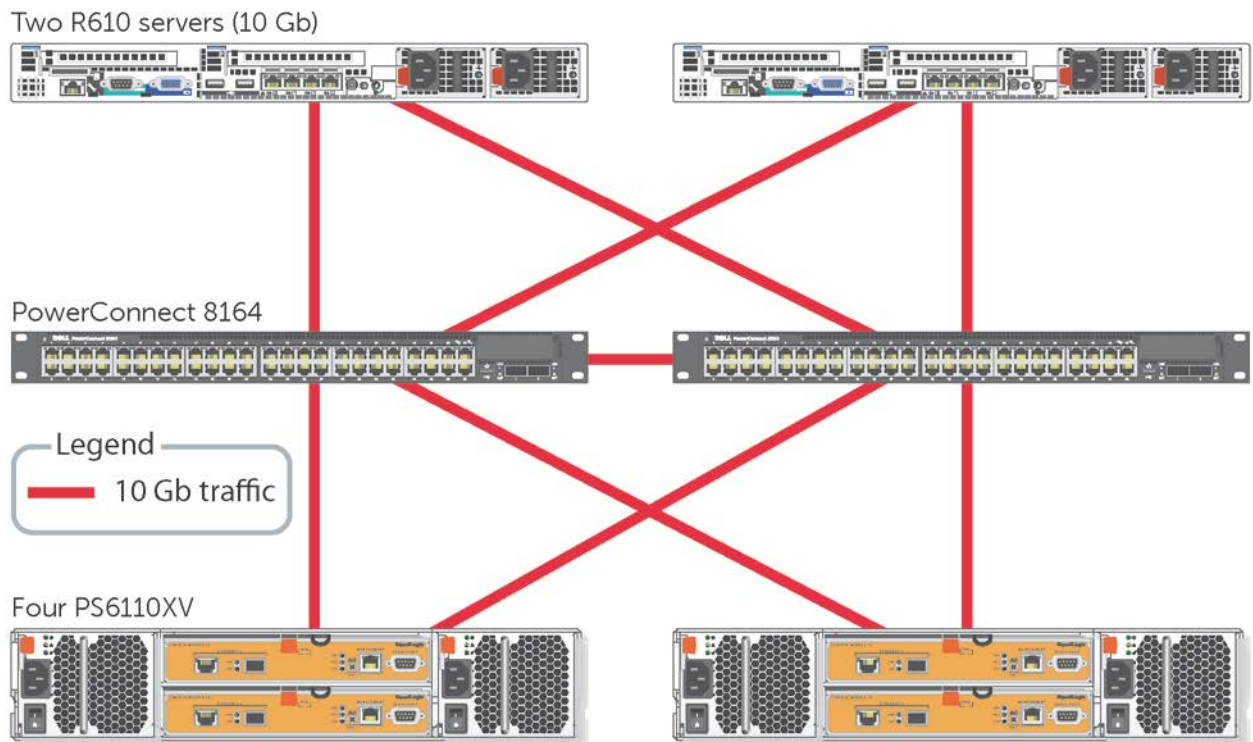

Figure 4 Test configuration 4

5 Results and analysis

Note: The results provided in this paper are intended for the purpose of comparing the specific configurations used in our lab environment. The results do not portray the maximum capabilities of any system, software, or storage.

The graph in Figure 5 shows a performance comparison of a pure 1 Gb environment (test configuration 1 - baseline) and a 1 Gb environment utilizing the PowerConnect 8164 10 Gb switch auto-negotiated down to 1 Gb speeds (test configuration 2). All of the workloads previously defined are shown. This graph illustrates that running a 1 Gb environment using a 10 Gb switch auto-negotiated to 1 Gb has a minimal effect on the performance of the SAN.

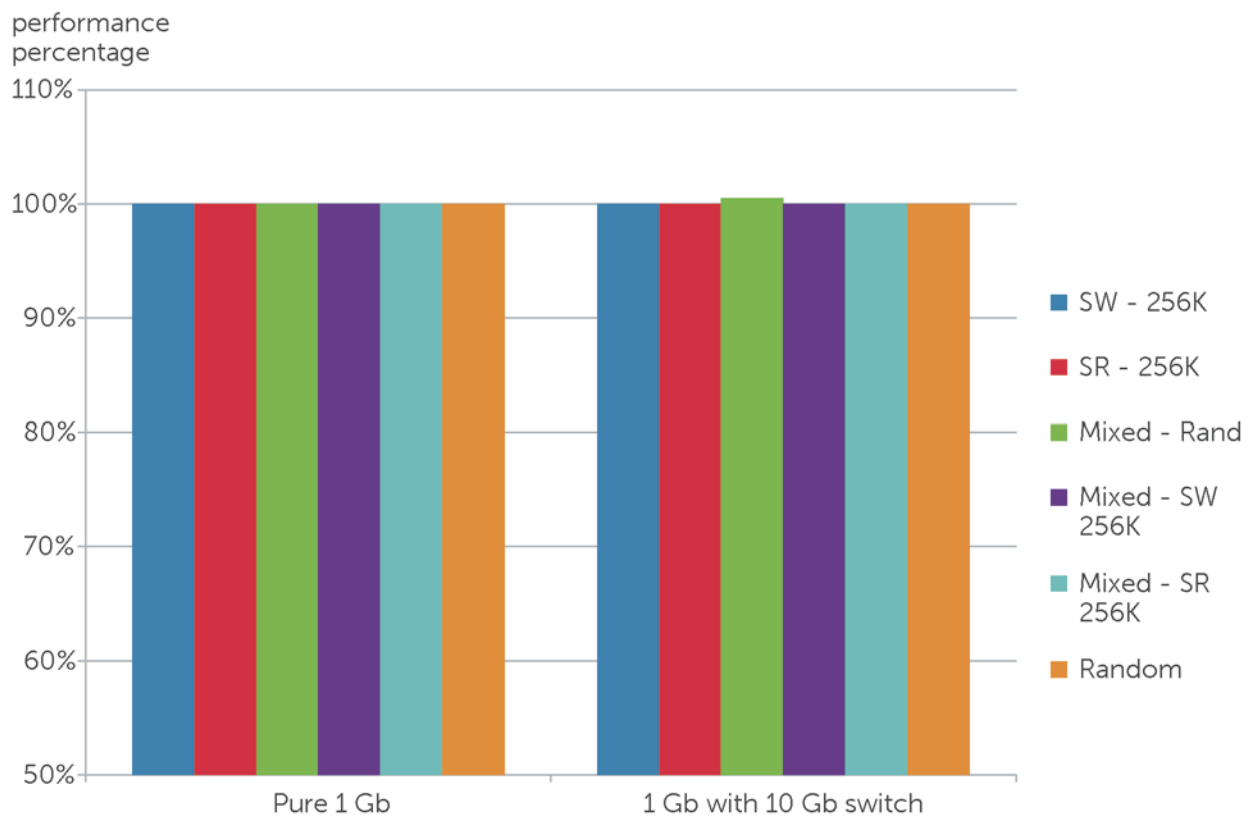

Figure 5 Pure 1 Gb versus 1 Gb with 10 Gb switch



The graph in Figure 6 shows the performance comparison of a pure 1 Gb environment (test configuration 1 - baseline) and a 1 Gb performance in a mixed speed environment with both 1 Gb and 10Gb devices connected to the same switch (test configuration 3). All the workloads previously defined are shown. Figure 6 illustrates running in a mixed speed environment with both 1 Gb and 10Gb devices connected to the same switch has very little effect on the 1 Gb performance of the SAN.

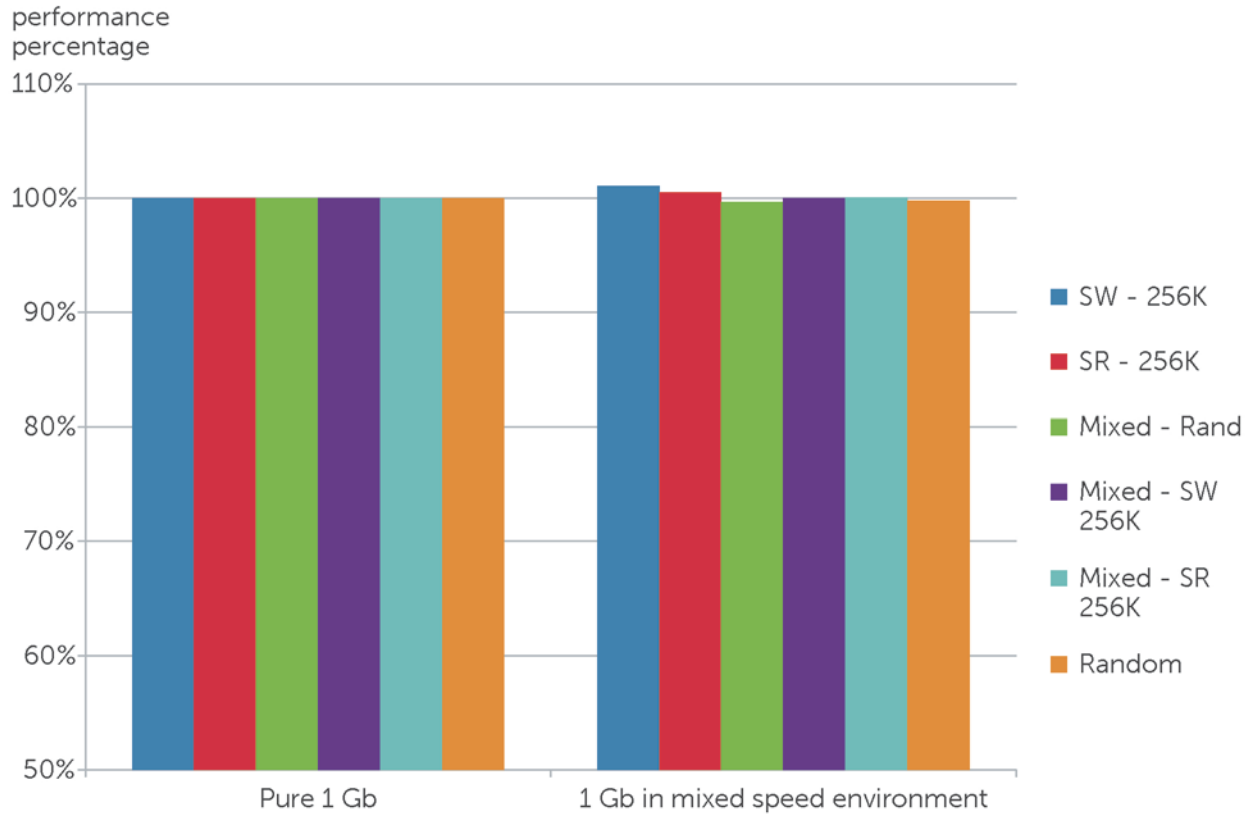

Figure 6 Pure 1 Gb versus 1 Gb in a mixed speed environment



The Figure 7 graph illustrates the performance comparison of a pure 10 Gb environment (test configuration 4 - baseline) and a 10 Gb in a mixed speed environment with both 1 Gb devices and 10 Gb devices connected to the same switch (test configuration 3). All the workloads previously defined are shown. This graph shows that running in a mixed speed environment with both 1 Gb and 10 Gb devices connected to the same switch has a very minor effect (< 3%) on the 10 Gb performance of the SAN.

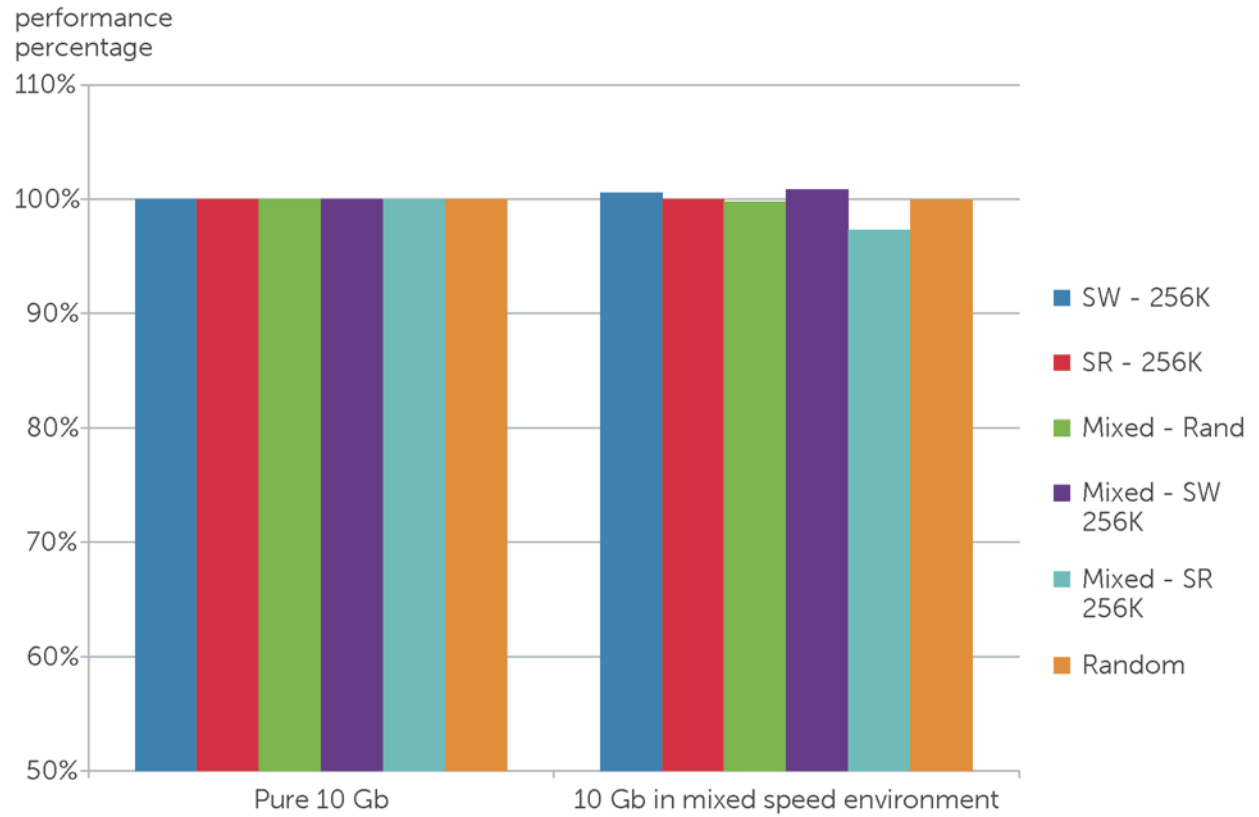

Figure 7 Pure 10 Gb versus 10 Gb in a mixed speed environment



6 Best practice recommendations

While transitioning from a pure 1 Gb infrastructure to a pure 10 Gb infrastructure, it may be necessary to have both 1 Gb and 10 Gb arrays in the same SAN infrastructure. For example, there are few applications that need the performance increase that comes with the addition of 10 Gb arrays. When running a mixed speed environment utilizing a common switch, the 1 Gb arrays and the 10 Gb arrays must be kept in separate pools. In addition to the arrays being separated into different pools, the 1 Gb hosts should only be connected to 1 Gb arrays and the 10 Gb hosts should only be connected to 10 Gb arrays. Connecting a 1 Gb host to a 10 Gb array or a 10 Gb host to a 1 Gb array can result in a host or array port overloading. This is because the 10 Gb ports have bandwidth capabilities that are ten times the 1 Gb port. For example, if a host port attempts to send ten times more data than the array port is able to process then it can result in dropped packets and will degrade the performance of the SAN.

When migrating from a 1 Gb to a 10 Gb environment, downtime of the network must be considered. Physically replacing a 1 Gb switch with a 10Gb switch requires downtime. After replacing the 1 Gb switch with the Powerconnect 8164, it has to be initially configured. Once configured the PowerConnect 8164 does not have to be re-configured for 1 Gb or 10 Gb operation. At this point, the user can connect the 10 Gb hosts and 10 Gb arrays to the switch to run in a mixed-speed environment.

Several methods are available to transition from a mixed speed environment to a pure 10 Gb environment. One method is to remove the 1 Gb hosts and arrays from the infrastructure and replace them with new 10 Gb hosts and arrays. This method requires a data migration from the 1 Gb arrays to the new 10 Gb arrays. EqualLogic includes a feature with the ability to move volumes from one storage pool (set of arrays) to another storage pool. Once the volumes (using "move volume") have been successfully moved from the 1Gb arrays to the new 10 Gb arrays, the 1 Gb arrays can be deleted and removed from the SAN group for repurposing. This feature, along with the ability to have 1 Gb arrays in the same SAN with 10 Gb arrays, provides a simple process for migrating from a pure 1 Gb solution to a pure 10 Gb solution.

Another method is to convert the existing 1 Gb hosts and arrays to 10 Gb. On the host side, this requires downtime in order to replace the 1 Gb NIC in the host with a 10 Gb NIC and to download and install new drivers, and other necessary software and firmware. After the correct 10 Gb network infrastructure and connections are in place, the arrays can be converted.

There are two available strategies depending on whether or not temporary data unavailability can be tolerated. Please note that testing these strategies was not within the scope of this paper.

Downtime strategy

If a short period (about 10-20 minutes) of data unavailability can be tolerated the downtime strategy should be used. The array to be converted is shut down, converted, and then brought back up to rejoin the group. This is the simpler of the two strategies; it takes the least amount of time, and requires no data movement. However, any volumes that are wholly or partially contained on the array that is being converted will be unavailable while it is shut down.



No downtime strategy

The no downtime strategy is used when data unavailability of any length is not an option. The array to be converted is first removed from the group (using the delete member operation), converted while out of the group, and then rejoined to the group. Since delete member moves all data off the array before removing it from the group, and maintains all volumes online and accessible while doing so, there is no downtime. However, this method takes a lot longer than the downtime method because the data must be migrated off, and then back onto the array that is being converted. This method also requires enough free space on the group to temporarily hold the data being moved from the array. If the extra space is not available another member can be temporarily added to the group.

7 Conclusion

This paper demonstrates that 1 Gb arrays and 10 Gb arrays can be connected to the same switch and mixed speed traffic can be run without any performance degradation. It also shows that a 1 Gb SAN using a 10 Gb switch with auto-negotiable 1 GbE/10 GbE ports will not experience any performance degradation, compared to a 1 GbE SAN using a 1Gb switch.



A Solution infrastructure details

Switch Configuration Guides are also published to provide step-by-step instructions for configuring Ethernet switches for use with EqualLogic PS Series storage using Dell best practices. These SCGs are located on Dell Tech Center at <http://en.community.dell.com/techcenter/storage/w/wiki/4250.switch-configuration-guides-by-sis.aspx>.

Switches	
Switch Model	PowerConnect 7048R
7048R Firmware	Firmware version: 4.2.1.3
Switch Model	PowerConnect 8164
8164 Firmware	Firmware version: 5.0.0.4

Server	
Server Model	PowerEdge R610
BIOS	Dell Inc. 6.2.3, 4/26/12
Processor	Intel(R) Xeon(R) CPU E5520 @ 2.27GHz, 2261 Mhz, 4 Core(s), 8 Logical Processor(s)
OS Name	Microsoft Windows Server 2008 R2 Enterprise
OS Version	6.1.7601 SP1 Build 7601

Network Adapter (1G)	
Model	Broadcom BCM5709C NetXtreme II GigE (NDIS VBD Client)
Driver Version	7.2.8.0
Profile	Storage Server
Jumbo Packet	9000 Bytes
Flow Control	RX/TX enabled



iSCSI initiator version	6.1.7601.17514
RX buffers	3000
TX Buffers	5000

Network Adapter (10G)	
Model	Intel(R) Ethernet 10G 2P X540-t
Driver Version	2.11.114.0
Use Data Center Bridging	Disabled
Profile	Storage Server
Jumbo Packet	9014 Bytes
Flow Control	RX/TX enabled
iSCSI initiator version	6.1.7601.17514
RX buffers	4096
TX Buffers	16384

MPIO Config	
HITKit version	4.0.0.6163
MPIO Device Specific Module	Maximum sessions per slice:2
	Maximum sessions per volume:6
Default Load Balancing Policy	Least Queue Depth

Array (1G)	
Model	PS6100XV
Firmware	6.0.1 (R264419)
Enable performance load balancing in pools	disabled



Array (1G)	
Raid Type	RAID 10
Control module	Model70-0400(TYPE 11)
Boot ROM	3.6.4
Cables to Switch	CAT6 copper



Array (10G)	
Model	PS6110XV
Firmware	6.0.1 (R264419)
Enable performance load balancing in pools	disabled
Raid Type	RAID 10
Control module	model70-0477 (TYPE 14)
Boot ROM	3.9.1
Cables to Switch	CAT6 copper



B VDbench parameters

sd=A-a,lun=\\.\PhysicalDrive1

sd=A-b,lun=\\.\PhysicalDrive2

sd=A-c,lun=\\.\PhysicalDrive3

sd=A-d,lun=\\.\PhysicalDrive4

sd=A-e,lun=\\.\PhysicalDrive5

sd=A-f,lun=\\.\PhysicalDrive6

sd=A-g,lun=\\.\PhysicalDrive7

sd=A-h,lun=\\.\PhysicalDrive8

sd=A-i,lun=\\.\PhysicalDrive9

sd=A-j,lun=\\.\PhysicalDrive10

sd=A-k,lun=\\.\PhysicalDrive11

sd=A-l,lun=\\.\PhysicalDrive12

sd=A-m,lun=\\.\PhysicalDrive13

sd=A-n,lun=\\.\PhysicalDrive14

sd=A-o,lun=\\.\PhysicalDrive15

sd=A-p,lun=\\.\PhysicalDrive16

sd=B-a,lun=\\.\PhysicalDrive1,range=(0m,10m),hitarea=1m

sd=B-b,lun=\\.\PhysicalDrive2,range=(0m,10m),hitarea=1m

sd=B-c,lun=\\.\PhysicalDrive3,range=(0m,10m),hitarea=1m

sd=B-d,lun=\\.\PhysicalDrive4,range=(0m,10m),hitarea=1m

sd=B-e,lun=\\.\PhysicalDrive5,range=(0m,10m),hitarea=1m

sd=B-f,lun=\\.\PhysicalDrive6,range=(0m,10m),hitarea=1m

sd=B-g,lun=\\.\PhysicalDrive7,range=(0m,10m),hitarea=1m



sd=B-h,lun=\\.\PhysicalDrive8,range=(0m,10m),hitarea=1m
sd=B-i,lun=\\.\PhysicalDrive9,range=(0m,10m),hitarea=1m
sd=B-j,lun=\\.\PhysicalDrive10,range=(0m,10m),hitarea=1m
sd=B-k,lun=\\.\PhysicalDrive11,range=(0m,10m),hitarea=1m
sd=B-l,lun=\\.\PhysicalDrive12,range=(0m,10m),hitarea=1m
sd=B-m,lun=\\.\PhysicalDrive13,range=(0m,10m),hitarea=1m
sd=B-n,lun=\\.\PhysicalDrive14,range=(0m,10m),hitarea=1m
sd=B-o,lun=\\.\PhysicalDrive15,range=(0m,10m),hitarea=1m
sd=B-p,lun=\\.\PhysicalDrive16,range=(0m,10m),hitarea=1m

sd=C-a,lun=\\.\PhysicalDrive1
sd=C-b,lun=\\.\PhysicalDrive2
sd=C-c,lun=\\.\PhysicalDrive3
sd=C-d,lun=\\.\PhysicalDrive4
sd=C-e,lun=\\.\PhysicalDrive5
sd=C-f,lun=\\.\PhysicalDrive6
sd=C-g,lun=\\.\PhysicalDrive7
sd=C-h,lun=\\.\PhysicalDrive8

sd=D-a,lun=\\.\PhysicalDrive9,range=(0m,10m),hitarea=1m
sd=D-b,lun=\\.\PhysicalDrive10,range=(0m,10m),hitarea=1m
sd=D-c,lun=\\.\PhysicalDrive11,range=(0m,10m),hitarea=1m
sd=D-d,lun=\\.\PhysicalDrive12,range=(0m,10m),hitarea=1m
sd=E-e,lun=\\.\PhysicalDrive13,range=(0m,10m),hitarea=1m
sd=E-f,lun=\\.\PhysicalDrive14,range=(0m,10m),hitarea=1m
sd=E-g,lun=\\.\PhysicalDrive15,range=(0m,10m),hitarea=1m
sd=E-h,lun=\\.\PhysicalDrive16,range=(0m,10m),hitarea=1m



wd=wd1,sd=A-*,seekpct=100,rdpct=67,xfersize=8k,iorate=9999999,priority=1

wd=wd2,sd=B-*,seekpct=0,rdpct=100,rhpct=100,whpct=100,xfersize=256k,iorate=9999999,priority=1

wd=wr1,sd=B-*,seekpct=0,rdpct=0,xfersize=256k,rhpct=100,whpct=100,iorate=9999999,priority=1

* Rand 8K I/O on 50% volumes

wd=wm1,sd=C-*,seekpct=100,rdpct=67,xfersize=8k

* Seq Read 256K on 25% volumes

wd=wm2,sd=D-*,seekpct=0,rdpct=100,rhpct=100,whpct=100,xfersize=256k

* Seq Write 256K on 25% volumes

wd=wm3,sd=E-*,seekpct=0,rdpct=0,xfersize=256k,rhpct=100,whpct=100

rd=rd1,wd=wr1,elapsed=10800,interval=30,forthreads=5

rd=rd2,wd=wd2,elapsed=10800,interval=30,forthreads=5

rd=rd3,wd=wd1,elapsed=10800,interval=30,forthreads=5

rd=rd1,wd=wm*,elapsed=10800,interval=30,forthreads=5,iorate=9999999



Additional resources

Support.dell.com is focused on meeting your needs with proven services and support.

DellTechCenter.com is an IT Community where you can connect with Dell Customers and Dell employees for the purpose of sharing knowledge, best practices, and information about Dell products and your installations.

Referenced or recommended Dell publications:

- Dell EqualLogic Configuration Guide:
<http://en.community.dell.com/techcenter/storage/w/wiki/2639.equallogic-configuration-guide.aspx>
- Deploying Mixed 1 Gb-10 Gb Ethernet SANs using Dell EqualLogic Storage Arrays
<http://en.community.dell.com/techcenter/storage/w/wiki/2640.deploying-mixed-1-gb-10-gb-ethernet-sans-using-dell-equallogic-storage-arrays-by-sis.aspx>

For EqualLogic best practices white papers, reference architectures, and sizing guidelines for enterprise applications and SANs, refer to Storage Infrastructure and Solutions Team Publications at:

- <http://dell.to/sM4hJT>





This white paper is for informational purposes only. The content is provided as is, without express or implied warranties of any kind.