

Dell EqualLogic Best Practices Series

Best Practices for Oracle 11g Backup and Recovery using Oracle Recovery Manager (RMAN) and Dell EqualLogic Snapshots

A Dell Technical Whitepaper

This document has been archived and will no longer be maintained or updated. For more information go to the [Storage Solutions Technical Documents page on Dell TechCenter](#) or contact support.

Storage Infrastructure and Solutions Engineering

Dell Product Group

May 2011

THIS WHITE PAPER IS FOR INFORMATIONAL PURPOSES ONLY, AND MAY CONTAIN TYPOGRAPHICAL ERRORS AND TECHNICAL INACCURACIES. THE CONTENT IS PROVIDED AS IS, WITHOUT EXPRESS OR IMPLIED WARRANTIES OF ANY KIND.

© 2011 Dell Inc. All rights reserved. Reproduction of this material in any manner whatsoever without the express written permission of Dell Inc. is strictly forbidden. For more information, contact Dell.

Dell, the *DELL* logo, and the *DELL* badge, *PowerConnect™*, *EqualLogic™*, *PowerEdge™* and *PowerVault™* are trademarks of Dell Inc. *Broadcom™* is a registered trademark of Broadcom Corporation. *Intel™* is a registered trademark of Intel Corporation in the U.S. and other countries. *Microsoft™*, *Windows™*, *Windows Server™*, and *Active Directory™* are either trademarks or registered trademarks of Microsoft Corporation in the United States and/or other countries.

Table of Contents

1	Introduction – key database administration challenges	5
1.1	How this paper can help you meet these challenges	5
1.2	Audience	6
1.3	The rest of this paper	6
2	Oracle backup and recovery strategies overview	7
3	Backup solution architecture	9
3.1	Database layout	10
4	Test design and results: RMAN	13
4.1	RMAN full backup and recovery	13
4.1.1	Database backup time: RMAN full backup	15
4.1.2	Performance impact: RMAN full backup	15
4.1.3	Database complete recovery time: RMAN full backup	16
4.2	RMAN incremental backup and recovery	16
4.2.1	Database backup time: RMAN incremental	16
4.2.2	Performance impact: RMAN incremental backup	17
4.2.3	Database complete recovery time	17
5	Test design and results: RMAN offload using EqualLogic snapshots	18
5.1	EqualLogic volume and snapshot collections	20
5.2	Virtualized backup server	22
5.3	Backup and recovery procedure using EqualLogic snapshots and RMAN	22
5.4	Performance impact	23
5.5	Database complete recovery time	23
6	Test design and results: point-in-time recovery using Oracle FLASHBACK DATABASE vs. EqualLogic snapshots	24
6.1	Point-in-time recovery using Oracle FLASHBACK DATABASE	24
6.2	Point-in-time recovery using EqualLogic snapshots	25
6.3	Point-in-time recovery using FLASHBACK DATABASE and EqualLogic snapshots – test results	26
7	Conclusions from test results	27
7.1	Database backup – key observations	27
7.2	Database recovery – key observations	28

7.3	Comparison of backup and recovery methods.....	30
8	Best practices for backup and recovery.....	32
8.1	Use a Virtualized Database Backup Server	32
8.2	RMAN backup	32
8.3	Snapshot reserve space sizing	32
8.4	Point-in-time recovery using Oracle FLASHBACK DATABASE	33
8.5	Discovering ORACLE ASM disks on the backup server	33
8.6	Persistent device mapping on the virtualized backup server	33
8.7	Upgrade Broadcom 57711 driver	33
8.8	RMAN configuration parameters.....	34
Appendix A	Test system component details.....	35
Appendix B	Automation of snapshot-based backup.....	37
Related publications	39

Acknowledgements

This whitepaper was produced by the PG Storage Infrastructure and Solutions team between January 2011 and April 2011 at the Dell Labs facility in Round Rock, Texas.

The team that created this whitepaper:

Chidambara Shashikiran, Suresh Jasrasaria, and Chris Almond

We would like to thank the following Dell team members for providing significant support during development and review:

Keith Swindell and Darren Miller

Feedback

We encourage readers of this publication to provide feedback on the quality and usefulness of this information. You can submit feedback as follows:

- Use the "[Post a new thread](#)" link here:

<http://www.delltechcenter.com/page/Oracle+11g+Backup+and+Recovery+using+RMAN+and+EqualLogic+Snapshots>

1 Introduction – key database administration challenges

Managing Oracle® database backup and recovery is a critical operational requirement for database and SAN administrators. Recovery Point Objective (RPO) and Recovery Time Objective (RTO) are the key requirements that influence design of a data protection solution. With increasing database sizes and stringent SLAs (some requiring 24x7-database availability), IT administrators need to effectively design and manage data protection solutions to minimize performance impact on production databases while supporting RPO and RTO requirements.

Below are some of the key operational goals that IT database administrators (DBAs) need to focus on in Oracle environments:

- Minimize performance impact on the production database when executing backup/restore operations
- Configure backup tasks to achieve the highest efficiencies and optimal RPOs
- Configure database restore and recovery tasks to achieve optimal RTOs
- Efficiently use all storage, server, and network resources while meeting quality of service (QoS) requirements
- Minimize DBA/system administrator time requirements for managing backup and recovery processes

1.1 How this paper can help you meet these challenges

This paper presents frequently used approaches for performing backup and recovery of Oracle databases using the Oracle provided utilities RMAN (Recovery Manager) and FLASHBACK DATABASE. We focus on the following topics:

- How IT administrators can use Dell EqualLogic snapshots to complement Oracle RMAN and FLASHBACK DATABASE features to achieve better RTO and RPO.
- Key results and important observations based on different approaches for database backup/recovery.
- Basic guidelines and best practices based on the tests results.

Backup and recovery solutions using the following methods are described and tested:

- Oracle Recovery Manager (RMAN) Full Backup
- Oracle RMAN Incremental Backups
- User-managed disk-to-disk backup and recovery using RMAN and EqualLogic Snapshots
- Point-in-time Recovery using the Oracle FLASHBACK DATABASE feature and using EqualLogic Snapshots

The combination of the two approaches—RMAN and user-managed backup with EqualLogic snapshots—offers excellent options for addressing the operational concerns mentioned above. In this combined approach, snapshots created after placing the production database in hot backup mode are

mounted on a different server (the backup server show in Figure 5 on page 19). The snapshots are mounted as an Oracle instance by the backup server and the database is backed from those volume snapshots using RMAN. As a result, all benefits of using RMAN backup are realized while also taking advantage EqualLogic PS Series storage features to minimize impact on production quality of service. This method provided several benefits, which we present in Section 8, Best practices for backup and recovery

1.2 Audience

This paper is useful for Oracle Database Administrators, Storage Architects and Linux System Administrators interested in optimizing the combined features that Oracle RMAN and EqualLogic PS Series storage arrays provide in meeting backup and recovery requirements. The discussion assumes that the readers of this document have familiarity with Red Hat Enterprise Linux system administration and Oracle 11g R2 database installation and administration tasks.

1.3 The rest of this paper

The rest of this paper contains the following sections:

- Section 2, **Oracle backup and recovery strategies overview** on page 7
- Section 3, **Backup solution architecture** on page 9
- Section 4, **Test design and results** on page 13
- Section 5, **Test design and results: RMAN offload using EqualLogic snapshots** on page 18
- Section 6, **Test design and results: point-in-time recovery using Oracle FLASHBACK DATABASE vs. EqualLogic snapshots** on page 24
- Section 7, **Conclusions from test results** on page 27
- Section 8, **Best practices for backup and recovery** on page 32

2 Oracle backup and recovery strategies overview

IT administrators can back up and recover an Oracle database using multiple methods, with each method having its own advantages and disadvantages. The choice of method to use depends on various factors, such as backup window requirements, recovery point, and recovery time objectives.

The EqualLogic volume snapshots feature used in conjunction with RMAN can help improve the overall efficiency of backup and recovery operations. EqualLogic snapshots also provide the ability to offload the RMAN backup copy operation to a dedicated backup processing server. This helps to reduce the impact on precious production database server system resources during backup processing.

Table 1 lists the most frequently used backup and recovery methodologies.

Table 1 – Oracle Backup and Recovery Methodologies

Methodology	Description
Disk-to-Tape Backup	The “classic” form of backup, in which the data is copied directly to tape drives. Provides the most economical solution for archiving the data for extended periods. Tape based backups are portable and a good choice for off-site storage. However, there are performance implications since the backup and recovery operations take significant time to complete.
Disk-to-Disk Backup	One of the most common backup methods deployed today. Data is copied directly between storage disks, thereby decreasing the backup/recovery time significantly. In some cases a dedicated Virtual Tape Library (VTL) is employed. In other cases the backup application writes to disk in its own proprietary format. This solution has become more popular because the cost per gigabyte of high capacity disks is decreasing. However, disks are not easily portable like tapes and not suitable for long-term archiving and off-site storage.
Disk-to-Disk-to-Tape Backup	This method can provide the best of both worlds. Backups can be copied to the disks regularly, and then moved to tape for long-term storage. Using disks for regular backup helps decrease backup and recovery time while the use of tape enables long-term data retention and offsite data protection. This may involve using one or more backup utilities to manage the entire process.
Database - Complete Recovery	This method recovers the database to the most recent state without losing any committed transactions. This involves restoring the database to the most recent good backup and then applying all the changes using archived logs.
Database – Point-in-Time Recovery	This scenario is more common than the full database recovery. This happens typically when human errors occur (like deleting the contents of a table) or database corruptions to the database. The database is returned to its original state before the corruption occurred.

Table 2 summarizes the methods used in this paper to test and compare Oracle database backup and recovery solutions.

Table 2 – Oracle Backup and Recovery Solutions

Methodology	Description
Oracle RMAN Full Backup	Oracle Recovery Manager (RMAN) is a commonly used utility supplied by Oracle for performing backup and recovery of Oracle databases. Administrators can use this utility to perform disk-to-tape or disk-to-disk backups. RMAN is easy to use, and provides a wide range of flexible features for scheduling backup operations.
Oracle RMAN Incremental Backup	RMAN backup of data files can be full or incremental. A full backup consists of every used block of the data file. An incremental backup consists of only the data that changed since the previous incremental backup. The size of the incremental backups is usually smaller when compared to full backups.
EqualLogic Snapshots	An EqualLogic snapshot preserves a copy of the contents of a volume at a point in time. Creating snapshots on a regular basis enables protection from data loss due to human error, viruses, or database corruption. Snapshots are created instantaneously with no performance impact. Administrators can use snapshots to offload the backup operation to a different server, thereby reducing system resource usage on the production database servers. Snapshots are also very useful for preserving point-in-time copies of the production database.
User-Managed Backup	In this method, RMAN is not the primary tool used for performing backup and recovery. Instead, operating system or storage tools are used to copy the raw content of the database files.
Oracle FLASHBACK DATABASE	Point-in-time recovery traditionally involves restoring the database files from tape or disk and then applying the redo logs to complete the recovery to the desired RPO. The Oracle FLASHBACK DATABASE feature eliminates the need to restore the database from tape or disk, thus providing a more efficient way for completing database point-in-time recovery.

3 Backup solution architecture

For the tests detailed in this paper, we created a reference design architecture that closely simulates a production server, network, and storage environment. The Quest Benchmark Factory tool was used to simulate TPC-C workload on a two-node Oracle 11g R2 RAC production database. Oracle database full backup and recovery operations were performed using the Oracle RMAN utility. Figure 1 shows the test system configuration.

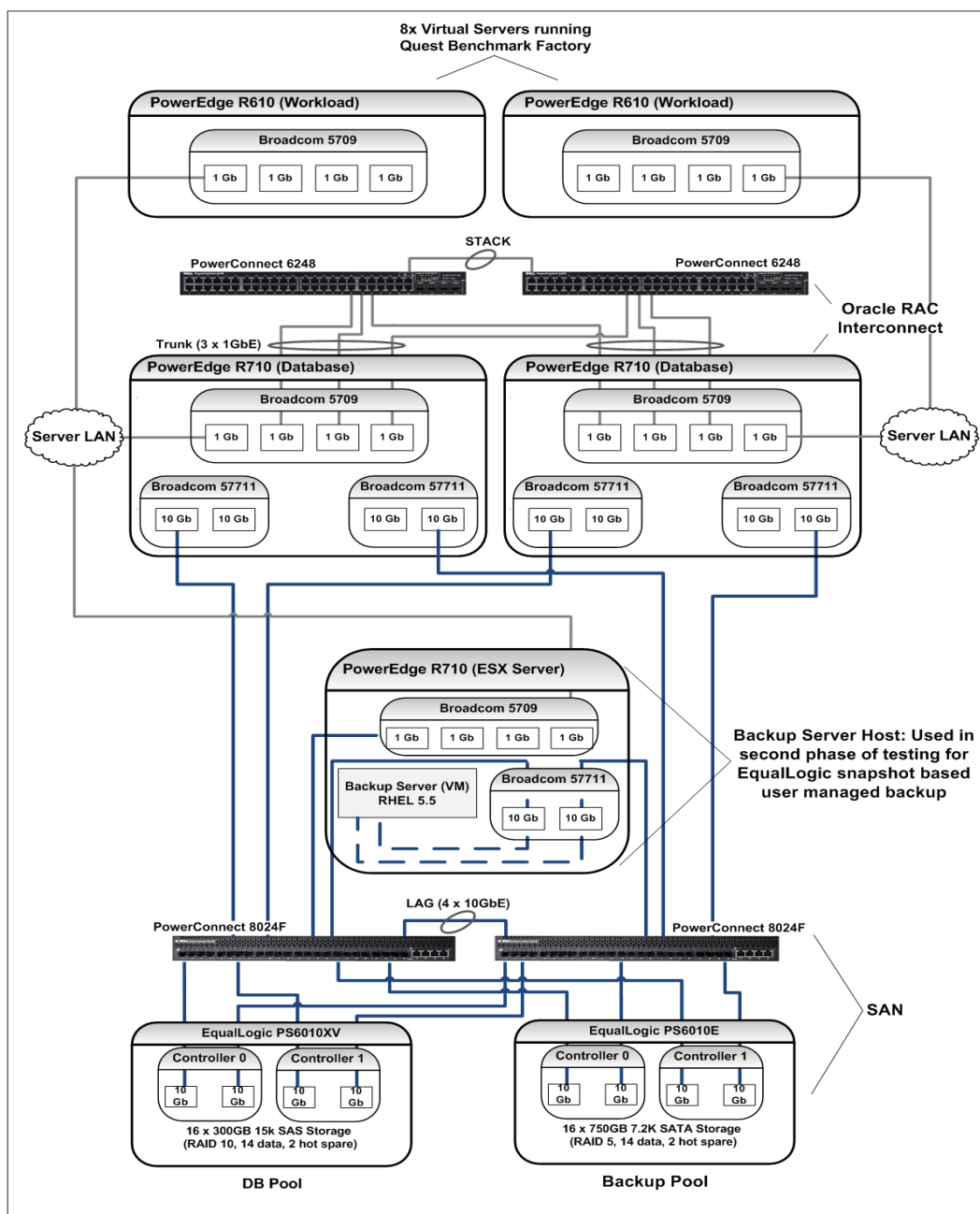

Figure 1 - Test System Configuration

Some key design details in the test system configuration:

- We hosted the Oracle 11g R2 RAC database on the two Dell PowerEdge R710 Database servers as shown in Figure 1.
- VMware ESX 4.1 was hosted on another, separate Dell PowerEdge R710 server. We configured a Linux VM (RHEL 5.5) on the ESX server to run Oracle.
- We stored the production database volumes on the EqualLogic PS6010XV array. The backup target volumes were stored on the EqualLogic PS6010E array. The database and backup arrays resided in separate pools in the same PS series group.
- Oracle ASM¹ (Automatic Storage Management) managed the database elements, redo logs, archives, and flash data.
- We stored the Oracle Clusterware files (OCR and voting disk) using the ASM cluster file system (ACFS).

Note: For the VMware ESX based backup server we used the RHEL iSCSI initiator in the guest OS. Doing this insured that that the Oracle instance on the backup server could be started using the same ASM disk group labels that were used by the production database server.

Refer to Appendix A for configuration details of each test system component.

3.1 Database layout

The EqualLogic arrays listed below were used for validating the solution:

- EqualLogic PS6010XV²:
 - 14 x 300GB 15K RPM SAS disk drives in a RAID 10 configuration with two hot spare disks
 - 10GbE dual-port controller running firmware version 5.0.2
- EqualLogic PS6010E³:
 - 14 x 700GB SATA drives in a RAID 50 configuration with two hot spare disks
 - 10GbE dual-port controller running firmware version 5.0.2

¹ <http://www.oracle-base.com/articles/10g/AutomaticStorageManagement10g.php>

² EqualLogic PS 6010XV Product details: <http://www.equallogic.com/products/default.aspx?id=8973>

³ EqualLogic PS 6010E Product details: <http://www.equallogic.com/products/default.aspx?id=8949>

The Oracle ASM disks were configured using the following layout:

ORADB	Database files; temporary table space; online redo logs; system related table spaces such as SYSTEM and UNDO
ORALOG	REDO logs
ORAARCH	Archive logs
ORAFLASH	Flash Recovery Area ⁴
ORACRS	ASM Cluster file system (ACFS) for storing Clusterware related information such as the OCR and voting disks

Table 3 shows the ASM Disk configuration used in each ASM Group for all tests. Figure 2 shows the containment model and relationships between the EqualLogic pool and volumes, and the Oracle ASM disk groups and disks.

Table 3 – ASM Disk Group Configuration

ORALOG	ORADB	ORAARCH	ORAFLASH	ORACRS
ORALOG1 (10GB) ORALOG2 (10GB)	ORADB1 (40GB) ORADB2 (40GB) ORADB3 (40GB) ORADB4 (40GB) ORADB5 (40GB) ORADB6 (40GB)	ORAARCH1 (80GB) ORAARCH2 (80GB) ORAARCH3 (80GB) ORAARCH4 (80GB) ORAARCH5 (80GB)	ORAFLASH1 (400GB) ORAFLASH2 (400GB) ORAFLASH3 (400GB) ORAFLASH4 (400GB) ORAFLASH5 (400GB)	ORACRS (5GB)

⁴ Flash Recovery Area is also used by Oracle FLASHBACK DATABASE for storing flashback logs. For more information, see: http://download.oracle.com/docs/cd/B28359_01/backup.111/b28270/rcmconfb.htm

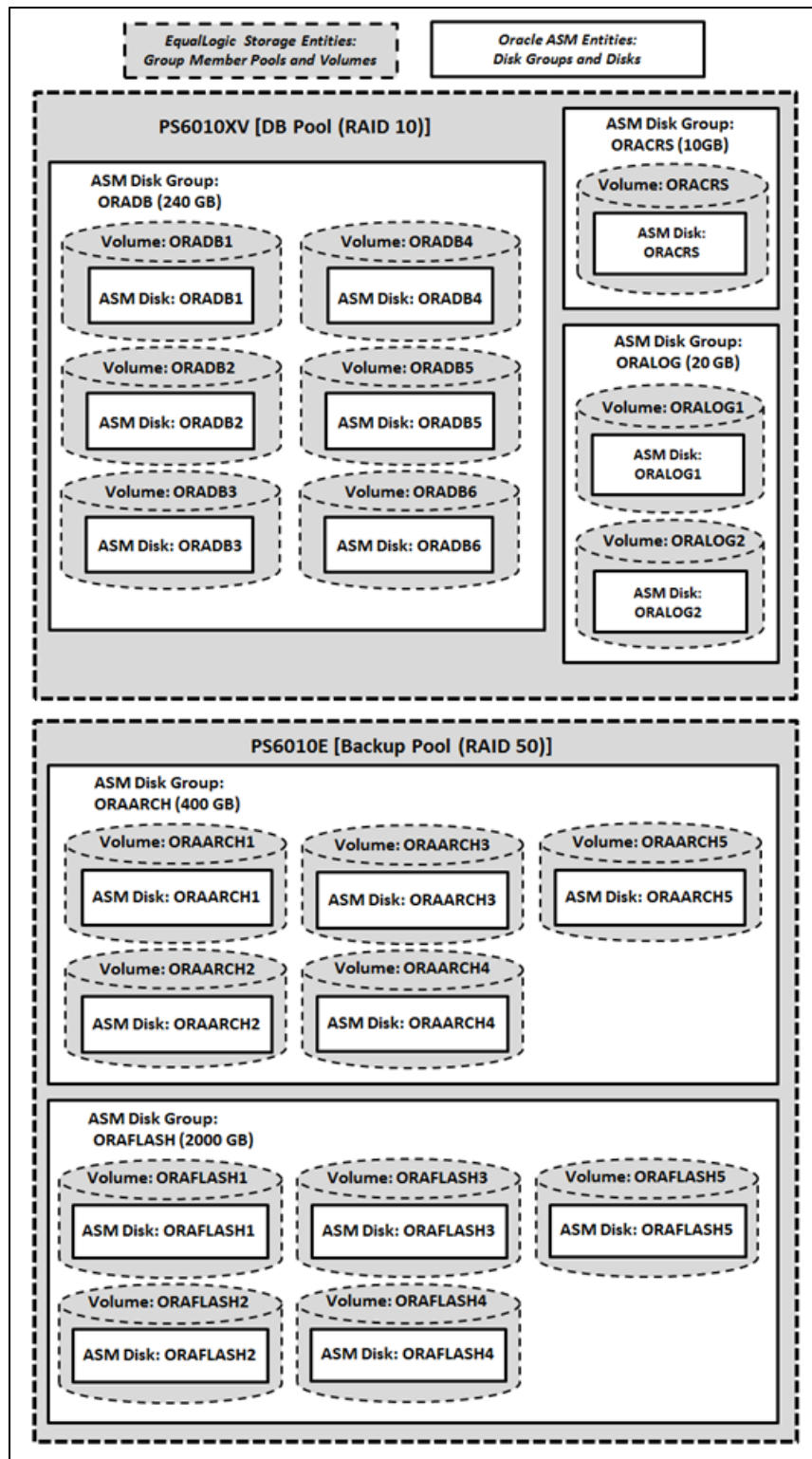

Figure 2 - Oracle disk groups and disks distribution on EqualLogic volumes

4 Test design and results: RMAN

First, we evaluated Oracle backup and recovery solutions using the native RMAN utility. Then we used EqualLogic snapshots along with RMAN to offload the backup processing to a backup server. We also compared point-in-time recovery methods using Oracle's FLASHBACK DATABASE utility vs. using EqualLogic snapshots.

Test plan summary:

- Measure performance impact of performing RMAN backup on the production database supporting TPC-C transaction load for 4000 concurrent users.
 - Backup operations included both RMAN full and incremental approaches.
 - Recovery operations were conducted from full and incremental backups.
- Evaluate the benefits of offloading the backup processing from the production database server to a dedicated backup server. Use EqualLogic based snapshots of production database volumes as the backup source data.
- For point-in-time recovery operations, compare use of Oracle's FLASHBACK DATABASE vs. EqualLogic snapshots.

4.1 RMAN full backup and recovery

In this phase of our testing we ran typical RMAN backup and recovery operations, where the database server also hosts RMAN processing. We used the system configuration shown in Figure 1. Figure 3 below illustrates the data flow.

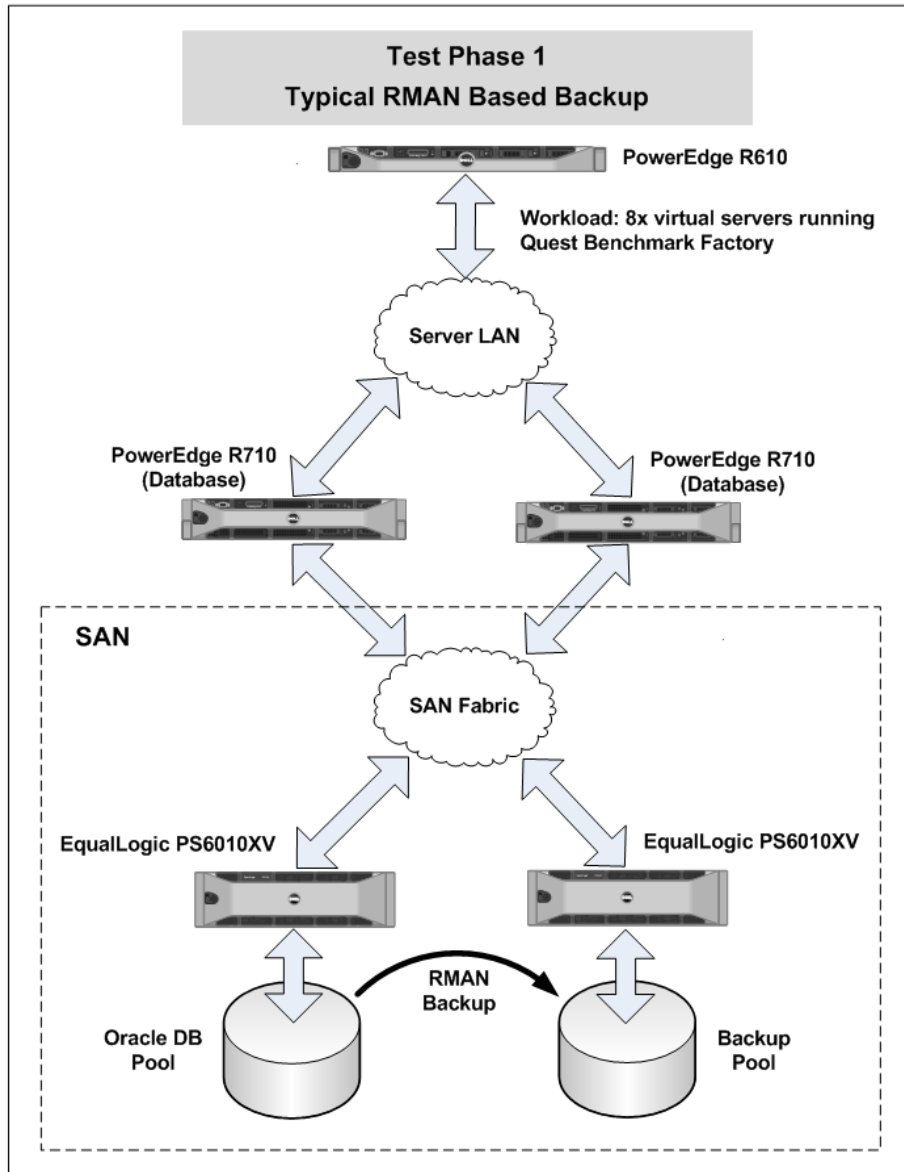

Figure 3 –System components: Test phase 1 typical RMAN based backup

We used Quest Benchmark Factory to simulate a TPC-C workload of 4000 concurrent users on the production database (Size = 200GB). The production database volumes resided on the EqualLogic PS6010XV array (15K SAS drives) and the backup target volumes were stored on the EqualLogic PS6010E array (SATA drives). The disk-to-disk backup and recovery operations from SAS to SATA drives were performed using the same database. We ran the following test sequence:

- Full database backup while running the TPC-C database workload
- Database recovery from full backup

4.1.1 Database backup time: RMAN full backup

The time necessary to create the full backup of our test database (while under TPC-C transactional load) is shown below.

RMAN Full Backup	Duration (Minutes)	Size (GB)
Time to create full backup	54	150

4.1.2 Performance impact: RMAN full backup

Figure 4 shows a composite chart illustrating the incremental impact on CPU utilization, database response time and transactions per second (TPS) caused by RMAN backup processing.

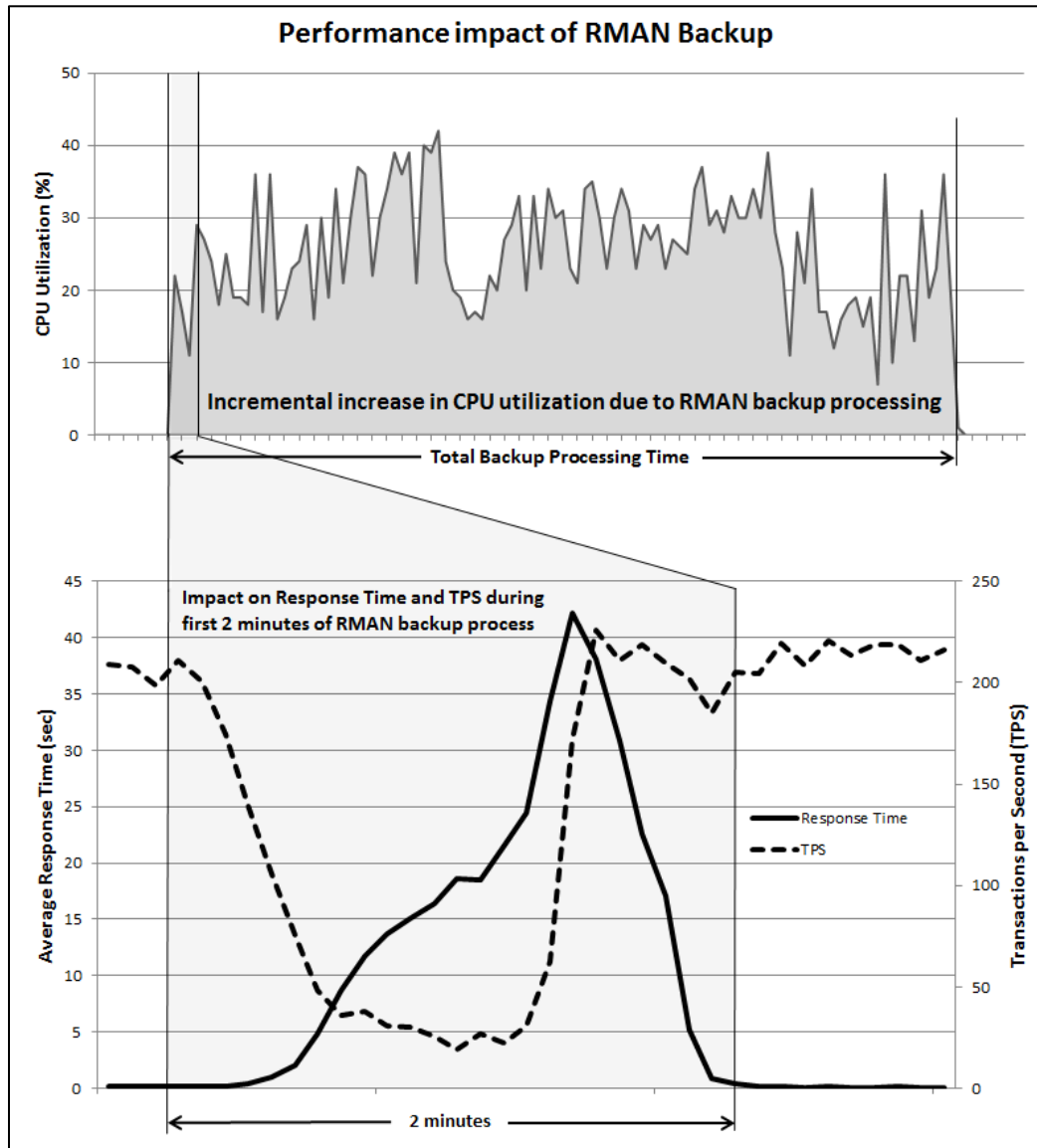

Figure 4 – Performance impact of RMAN backup

You can see in Figure 4 that a significant incremental increase in CPU utilization occurred at the start of RMAN backup processing. We also measured a significant impact on the performance of the production database (increase in response time and decrease in TPS shown in the bottom part of Figure 4). The impact on the production database is due to how RMAN quiets database I/O activity at the beginning of the process. Measurable impact on database performance was limited to the first two minutes of the backup process, while the CPU impact remained during the entire duration of RMAN backup processing.

4.1.3 Database complete recovery time: RMAN full backup

The database recovery operation after an RMAN full backup involves restoring the database to the previous full backup point, then applying all redo logs necessary to reach the recovery point objective.

The time to complete database recovery depends primarily on:

- The age of the previous full backup.
- The volume of transactions recorded in the redo logs.

We continued to run the 4000 user TPC-C workload on the 200GB production database for 6 hours after completing an initial RMAN full backup. After six hours we completed an RMAN restore and recovery process. The redo logs generated after the previous backup were used for database recovery. We measured the following restore and recovery times:

- **Time to restore the database:** 45 minutes
- **Time to recover the database using redo logs:** 106 minutes
- **Total recovery time:** 151 minutes

4.2 RMAN incremental backup and recovery

During this test we executed the same backup and recovery scenarios using RMAN incremental backups instead of a full backup. We ran the following test sequence:

- Created incremental backups (level 0 + level 1) while running the TPC-C database workload
- Database recovery from incremental backup

4.2.1 Database backup time: RMAN incremental

The level 1 backup was initiated after running the TPC-C transactions for 2.5 hours past completion of the level 0 backup. The time necessary to create the level 0 and level 1 backups of our test database (while under TPC-C transactional load) are shown below.

RMAN Incremental backup	Duration (Minutes)	Size (GB)
Time to create Level 0 backup	56	150
Time to create Level 1 backup	50	50

During a level 1 incremental backup and onwards, RMAN verifies every block in the data files to detect if any modifications have occurred since the previous incremental backup. If there are modifications, then only the blocks containing modifications will be copied. As a result, size of incremental backups (level 1 and onwards) is typically much less than level 0 or full backups.

Even though level 1 backup and incremental backups after level 1 were smaller in size, the time taken to complete those backups was almost same as level 0 or full backup. This is because RMAN will have to verify every block in the data files to identify if any modifications have occurred. This is the main drawback of this approach as it significantly increases the backup window, extending the RMAN processing impact on production database servers.

4.2.2 Performance impact: RMAN incremental backup

System performance impacts similar to those seen in the full backup test in Section 4.1.2 (CPU utilization, response time, TPS) were observed during the incremental backup tests.

4.2.3 Database complete recovery time

For the incremental recovery time test we ran the Quest Benchmark factory TPC-C style workload on the production database for six hours. At the beginning of the 6 hour period we created the level 0 incremental backup. Then approximately one-half way through the test period we created a level 1 incremental backup. Then we continued running the workload on the database to the end of the 6 hour test period. At that point, we initiated a restore/recovery process.

Timing results for incremental restore/recovery:

- **Time to restore the database:** 45 minutes
- **Time to recover the database:** 31 minutes
- **Total time:** 76 minutes

When comparing these results to the results in 4.1.3 for an RMAN full backup restore/recovery process you see that the recovery process took much less time (31 minutes vs. 106 minutes). The total time for the restore/recovery process was reduced from 151 minutes to 76 minutes.

These results show that use of incremental backups can significantly reduce the time to perform complete recovery of the database. But the drawback with this approach is that you increase the total amount of time that RMAN is running on the system. As illustrated in Section 4.1.2, this can have a significant impact on CPU resources, and thus may not be acceptable for many larger database environments.

5 Test design and results: RMAN offload using EqualLogic snapshots

In this phase of our testing we implemented a **user-managed backup process**, combining RMAN with EqualLogic snapshots. The following changes were made to the system design and backup process:

- RMAN backup and recovery operations were run on an additional virtualized server (instead of the same servers used for hosting the database workload).
- **EqualLogic based snapshots** of the database and redo logs were used as source data volumes for RMAN processing.

As we have shown in the preceding sections, a drawback of using the RMAN utility is that it competes for CPU resources on the database server. By using an additional Oracle database server to host the RMAN backup process we eliminate this problem. To run RMAN on the backup server, it will need to be able to mount the same ASM disk groups that contain the production database. To facilitate this we created a collection of array based snapshots of the volumes containing the ASM database disks and log disks using the EqualLogic Group Manager software. Figure 5 shows the addition of the backup server host and the volume snapshot collection to the test system configuration.

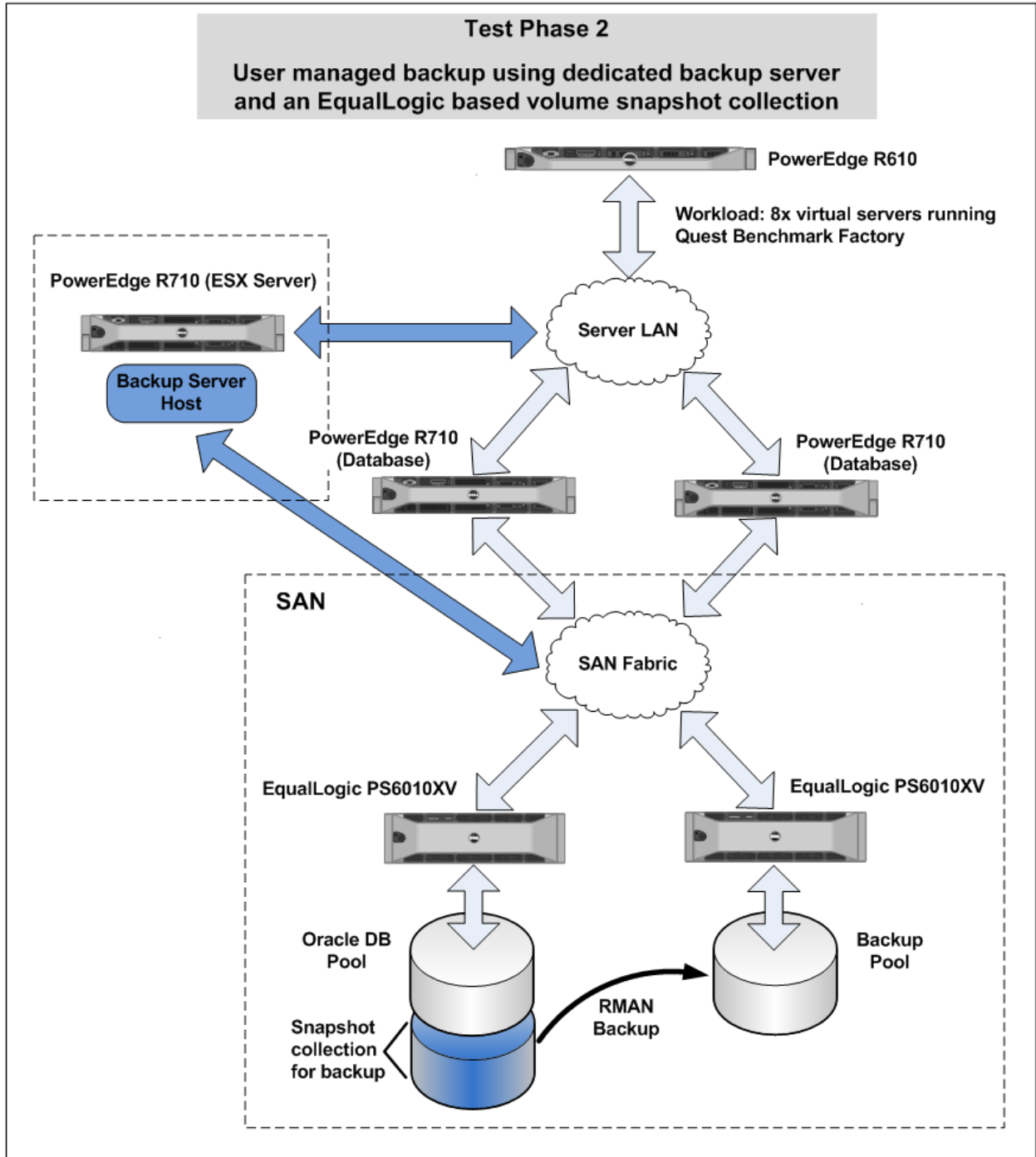

Figure 5 - System components: Test phase 2 user managed backup

5.1 EqualLogic volume and snapshot collections

EqualLogic PS Series arrays provide the ability to create Volume Collections. Volume collections are useful when you need to perform an operation simultaneously on multiple volumes. Once you have created a volume collection you can create a snapshot of the entire collection in one operation. This feature can be very useful in Oracle environments because Oracle database files are typically spread across multiple volumes. When you create a snapshot of a volume collection you maintain consistency across all volumes.

In our test configuration, the Oracle database was spread across six volumes on the array (ORADB1 to ORADB6). The redo log data was spread across two volumes (ORALOG1 and ORALOG2). (Refer to Table 3 in Section 3.1.) We created a volume collection group consisting of all the data file volumes and redo log volumes. The volume collection is shown Figure 6.

The screenshot shows the 'Volume collection ORADBDATALOG' interface. The left sidebar contains 'Activities' with options for 'Volume Collection', 'Snapshots', 'Schedules', and 'Replication'. The main area is divided into 'Collection Status' and 'Collection Volumes'.

Collection Status:

- Snapshots:** Snapshot collections: 1, Last snapshot collection: 2/18/11 9:12:34 AM
- Replication:** Collection is not replicated

Collection Volumes:

Total volumes in the collection: 8

Volume name	Storage pool	Reported size	Volume reserve	Snapshot reserve	Volume status	Replication partner	Number of snapshots	iSCSI connections
ORADB1	DBPOOL	40 GB	40 GB	120.01 GB	online		1	4
ORADB2	DBPOOL	40 GB	40 GB	120.01 GB	online		1	4
ORADB3	DBPOOL	40 GB	40 GB	120.01 GB	online		1	4
ORADB4	DBPOOL	40 GB	40 GB	120.01 GB	online		1	4
ORADB5	DBPOOL	40 GB	40 GB	120.01 GB	online		1	4
ORADB6	DBPOOL	40 GB	40 GB	120.01 GB	online		1	4
ORALOG1	DBPOOL	10 GB	10 GB	30.01 GB	online		1	4
ORALOG2	DBPOOL	10 GB	10 GB	30.01 GB	online		1	4

Figure 6 – Data file volume collection

A single snapshot creation operation on the volume collection shown in Figure 6 will create snapshots of all individual volumes that are part of that collection. The result of that operation is shown in Figure 7.

The screenshot shows the 'Snapshot Collection DBSNAP-2011-02-18-09:12:34.16283' interface. The left sidebar contains 'Activities' with options for 'Snapshot Collection'. The main area is divided into 'Snapshot Collection Status' and 'Snapshots'.

Snapshot Collection Status:

- General Information:** Created: 2/18/11 9:12:34 AM, Volume collection: ORADBDATALOG, Schedule:
- Description:** DatabaseSnap
- Status Summary:** Original number of snapshots: 8, Integrity: complete, Modification: potentially modified

Snapshots:

Total snapshots in the collection: 8

Snapshot	Volume	Storage Pool	Size	Status	Permission	Connections
2/18/11 9:12:34 AM	ORADB1	DBPOOL	40 GB	online	read-write, not shared	2
2/18/11 9:12:34 AM	ORADB2	DBPOOL	40 GB	online	read-write, not shared	2
2/18/11 9:12:34 AM	ORADB3	DBPOOL	40 GB	online	read-write, not shared	2
2/18/11 9:12:34 AM	ORADB4	DBPOOL	40 GB	online	read-write, not shared	2
2/18/11 9:12:34 AM	ORADB5	DBPOOL	40 GB	online	read-write, not shared	2
2/18/11 9:12:34 AM	ORALOG1	DBPOOL	10 GB	online	read-write, not shared	2
2/18/11 9:12:34 AM	ORALOG2	DBPOOL	10 GB	online	read-write, not shared	2
2/18/11 9:12:34 AM	ORADB6	DBPOOL	40 GB	online	read-write, not shared	2

Figure 7 – Snapshot Collection

Figure 8 illustrates this process, showing the new snapshot collection of data volumes that will be mounted by the backup server.

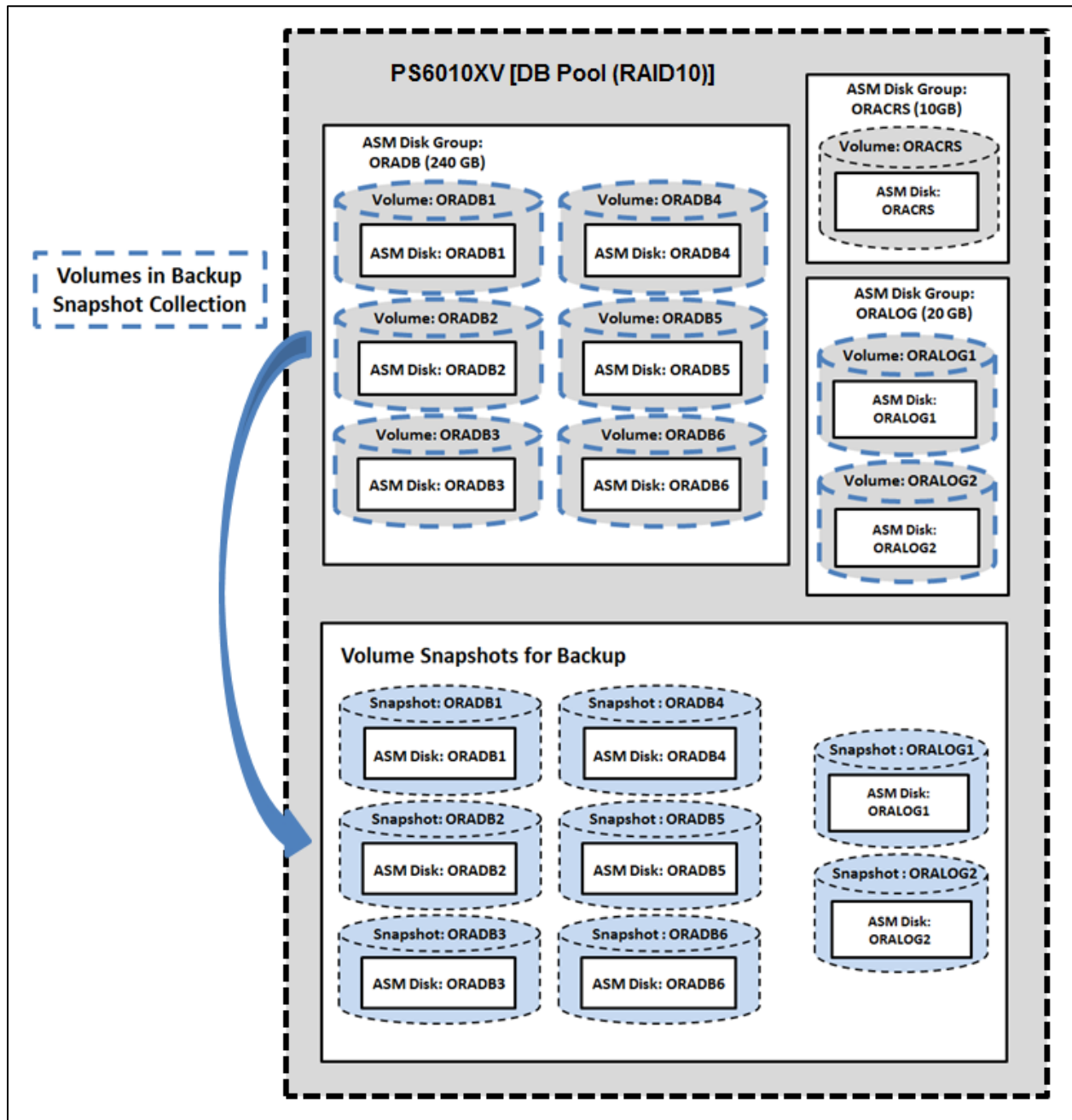

Figure 8 - Snapshot collection for user managed RMAN backup

5.2 Virtualized backup server

A backup server is an auxiliary host that runs Oracle RMAN and mounts the collection of volume snapshots described in the previous section.

Why run a dedicated backup server?

The backup server completely offloads the backup processing to a different host. This results in no impact due to RMAN processing on the production database servers. This server can also be used to install external backup agents. For example, you could run Symantec BackupExec "Disk-to-Tape" backup operations on this system.

Why virtualize the backup server?

RMAN backup processing does not require full-time dedicated server resources. A virtualization platform gives you the flexibility to share the system resources required by the backup process with other virtualized systems when backup or recovery operations are not running.

5.3 Backup and recovery procedure using EqualLogic snapshots and RMAN

In this section we provide an outline of the steps used to perform user managed database backup and recovery using EqualLogic snapshots and RMAN.

Snapshot-based backup:

1. Place the production database in hot backup mode.
2. Login to the EqualLogic group with the Group Manager GUI or CLI and create the snapshot of the volume collection (the Oracle database and redo log volumes). This step can also be automated using CLI scripts.
3. End the database hot backup mode.
4. Archive the redo logs so that the required redo logs are available for recovery.

We developed an Expect⁵ script to automate steps 1-4 above. The source code for that script is included in Appendix B on page 37.

RMAN backup using snapshots mounted on the virtualized backup server:

Note: the steps below can be automated using command scripts.

1. Using the EqualLogic Group Manager, place the snapshots online and configure them so that they can be mounted by backup server.

On the backup server:

2. Copy the database initialization parameter file and ASM instance parameter files from production database to appropriate locations on the backup server (this step is only required the first time this procedure is completed). Since the database will be mounted as a single

⁵ <http://expect.sourceforge.net/>

instance database on backup server, you need to remove all RAC related settings from the database parameter file.

3. Discover the iSCSI targets on the backup server after mounting the snapshots.
4. Login to the iSCSI targets.
5. Discover the Oracle ASM disks using the "oracleasm scandisks" utility. Since the mounted snapshots are copies of the original database volumes the original ASM labels are available.
6. Perform the steps detailed in section 8.5, Discovering ORACLE ASM disks on the backup server.
7. Start the Oracle ASM instance and mount the Oracle ASM disk groups.
8. Bring up the single instance database on backup server in the mounted state.
9. Perform an RMAN backup of the database on the backup server.

Recovery (on the production server):

Before restoring the database, the backup performed on the backup server needs to be registered in the production database control file. Use the RMAN "catalog backuppiece"⁶ feature to register the backup performed on the backup server in the control file of the production database. Once the backup is registered on the production database, restore and recovery operations can be performed using RMAN.

5.4 Performance impact

Before creating the snapshots of the database volume collection we had to place the database in hot backup mode to maintain consistency. EqualLogic snapshots are created almost instantaneously. Therefore, the time that the database needs to be placed in hot backup mode can be very short. After creating the snapshot collection and taking the database out of hot backup mode. After completing this process we did not see any performance impact on the production database server while RMAN backup was reading from the snapshot collection. The net effect of this method is that **we were able to perform RMAN backup and recovery operations without causing any impact on the production database system resources**, other than the short time period during which the database was in hot backup when creating the snapshot of the volume collection. This method offloads the CPU utilization impact shown in Figure 4 from the production database server.

5.5 Database complete recovery time

The database was recovered using the recovery procedure explained in section 5.3, Backup and recovery procedure using EqualLogic snapshots and RMAN.

- **Time to restore the database:** 50 minutes
- **Time to recover the database:** 90 minutes
- **Total time:** 140 minutes

The 200GB database was restored in 50 minutes. The complete recovery operation took 90 minutes.

⁶ Reference: Oracle Database Backup and Recovery Reference 11g Release 1:
http://download.oracle.com/docs/cd/B28359_01/backup.111/b28273/rcmsynta008.htm

6 Test design and results: point-in-time recovery using Oracle FLASHBACK DATABASE vs. EqualLogic snapshots

There are many scenarios where database administrators chose to recover databases to specific points in time. For example, if an error occurred (such as inadvertent table deletion or database corruption), the first thing a DBA does is recover the database to a time prior to when the database corruption occurred.

Traditional point-in-time recovery involves restoring the database files to the previous time and then applying the redo logs until you reach a point in time just before corruption occurred. This process can take a long time, depending on when the previous backup was performed and the number and size of the redo logs that need to be applied.

Oracle's FLASHBACK DATABASE is a feature that helps to accelerate the point in time recovery process. This feature provides a better alternative than standard point-in-time or incomplete recovery methods.

We also evaluated point-in-time recovery using EqualLogic based snapshots. The results presented in Section 6.3 show that you can significantly shorten the time required to complete point-in-time recovery (relative to Oracle FLASHBACK DATABASE) by using EqualLogic based snapshots.

6.1 Point-in-time recovery using Oracle FLASHBACK DATABASE

The high-level steps followed to configure Oracle FLASHBACK DATABASE feature are described below.

Configuration prerequisites:

- The database must be running in archivelog mode.
- A flash recovery area must be configured for the database.
- The database must have been put in FLASHBACK mode
- The flashback retention target parameter must be set. This parameter determines how far back the database can be rolled backwards.

High-level procedure for point-in-time recovery using Oracle FLASHBACK DATABASE (this process assumes that the flashback database feature is not enabled yet):

1. Perform a clean shutdown of the database. This is a mandatory requirement for enabling the FLASHBACK DATABASE feature.
2. Mount the database.
3. Enable FLASHBACK DATABASE feature
4. To recover the database to a point-in-time, shut down the database.

5. Start up the database in mount state.
6. Restore the database to a specific previous time using the System Change Number⁷ (SCN).
7. Once the flashback operation is complete, open the database using resetlogs.

Configuration Notes:

- The FLASHBACK DATABASE feature uses flashback logs to track database changes. If the flashback feature is enabled, then flashback logs are generated and are written sequentially to flash recovery area during normal database operation.
- When enabling the FLASHBACK DATABASE feature, the flash recovery area should be planned such that it can accommodate these logs. When we executed Quest Benchmark factory TPC-C tests simulating 4000 concurrent transactions, approximately 30GB of flashback logs were generated per hour.

6.2 Point-in-time recovery using EqualLogic snapshots

In this section we provide an outline of the steps necessary to complete a point-in-time recovery of the database using EqualLogic snapshots instead of using the Oracle FLASHBACK DATABASE feature.

On the production database server:

1. Dismount the Oracle database and redo log ASM disk groups.
2. Logout from the iSCSI initiators on the production database servers.

Using the EqualLogic Group Manager:

3. Set the Oracle database and redo log volumes offline on the EqualLogic group.
4. Perform a snapshot restore of the volumes on the EqualLogic group.

On the production database server:

5. Re-discover the iSCSI targets on the production database servers.
6. Login to the discovered iSCSI targets.
7. Rescan the Oracle ASM disks.
8. Shut down and then restart the ASM database instance on the production database servers.
9. Mount the Oracle database and the redo log ASM disk groups.
10. Bring the database instance to the mounted state.
11. Recover the database using the archived REDO logs.
12. Once the database recovery is complete, open the database.

⁷ From <http://www.orafag.com/wiki/SCN>: "A number, internal to Oracle that is incremented over time as change vectors are generated, applied, and written to the Redo log."

6.3 Point-in-time recovery using FLASHBACK DATABASE and EqualLogic snapshots – test results

In this section we compare recovery times using Oracle FLASHBACK DATABASE utility and EqualLogic snapshot based approaches.

The amount of time taken to recover a database using the FLASHBACK DATABASE feature is proportional to how far back the database needs to be rolled back. Usually this is less than the time necessary to restore and recover an entire database using RMAN. As shown in Figure 9, it took 63 minutes to recover the database using flashback by two hours, and 90 minutes to recovery it by four hours.

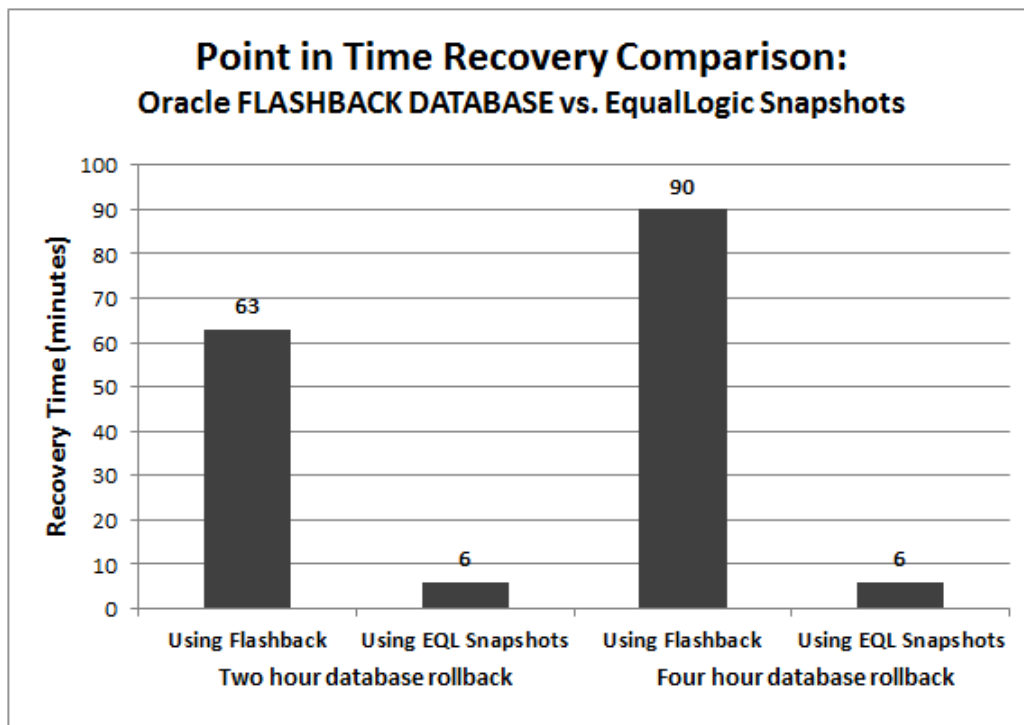

Figure 9 – Point in time recovery comparison

The test results clearly demonstrate that the amount of time taken to perform point-in-time recovery primarily depends on the amount of database transactions that have occurred from the point of recovery up until the current time.

Figure 9 also shows that the time taken to restore the database from an EqualLogic snapshot (using the procedure outlined in Section 6.2) remains the same regardless of whether the snapshot occurred two hours back or four hours back in time. This result illustrates a key advantage in using EqualLogic based snapshots vs. Oracle FLASHBACK DATABASE: you can meet much shorter RTO objectives using EqualLogic based snapshots.

7 Conclusions from test results

This section describes key observations captured during each test. The database backup and recovery operations were performed using RMAN full backup, RMAN incremental backup and EqualLogic snapshots. We also studied the point-in-time recovery operations of the database using Oracle's FLASHBACK DATABASE feature and EqualLogic snapshots.

7.1 Database backup – key observations

CPU Utilization

- We measured a significant impact on CPU utilization on the database server while performing RMAN backup operations. The CPU utilization increased significantly during the backup process. Also, database performance as measured by transactions per second (TPS) and Average response time was significantly impacted for a brief period (~two minutes) at the beginning of RMAN backup processing.
- Increasing the frequency of RMAN incremental backups amplifies the processing performance penalty described above.
- By using EqualLogic snapshots in the user managed backup scenario we were able to offload the RMAN CPU performance penalty to a dedicated backup server. In this scenario the impact on database performance was limited to a brief reduction in TPS and increase in response time while the database was placed in hot backup mode. During the rest of the backup operation the production database server was not affected.

Time to create backup

The time to create backups using three different methods is shown in Figure 10. The RMAN incremental backup time represents the total time required to create a level 0 backup (56 minutes) plus a level 1 backup (50 minutes).

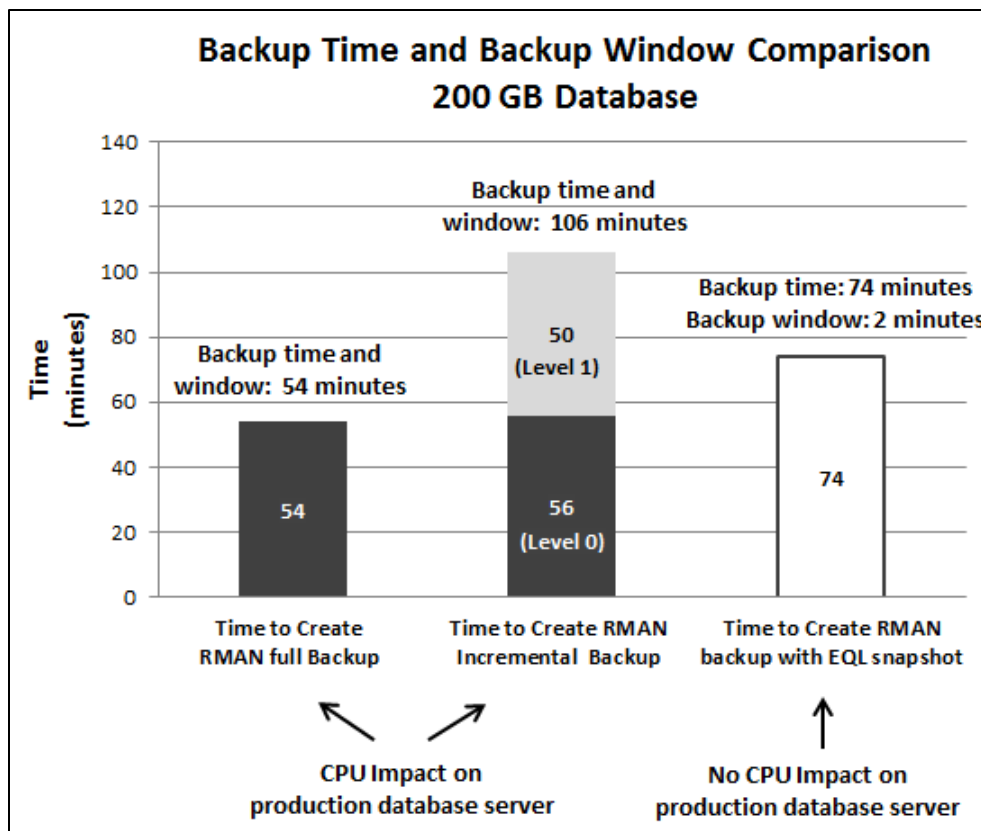

Figure 10 – Backup time comparison

7.2 Database recovery – key observations

Complete Recovery

Time to complete database recovery for the three different methods is shown in Figure 11.

- As expected, the time to complete recovery from an RMAN full backup when comparing regular RMAN to EqualLogic snapshot based RMAN was similar.
- Also as expected, the time to complete recovery from incremental RMAN backup was significantly lower than from full backup.

Complete database recovery time comparison 200 GB Database

Note: As shown in this chart, using RMAN incremental backups can reduce the time to recover the database. But this approach has the drawback of increasing the backup window time on the production database server significantly, which as we have demonstrated can have a significant impact on system resources (see Figure 4 and Figure 10). As a result, even though it helps in achieving a better recovery time objective, this approach may not be acceptable for many larger database deployments.

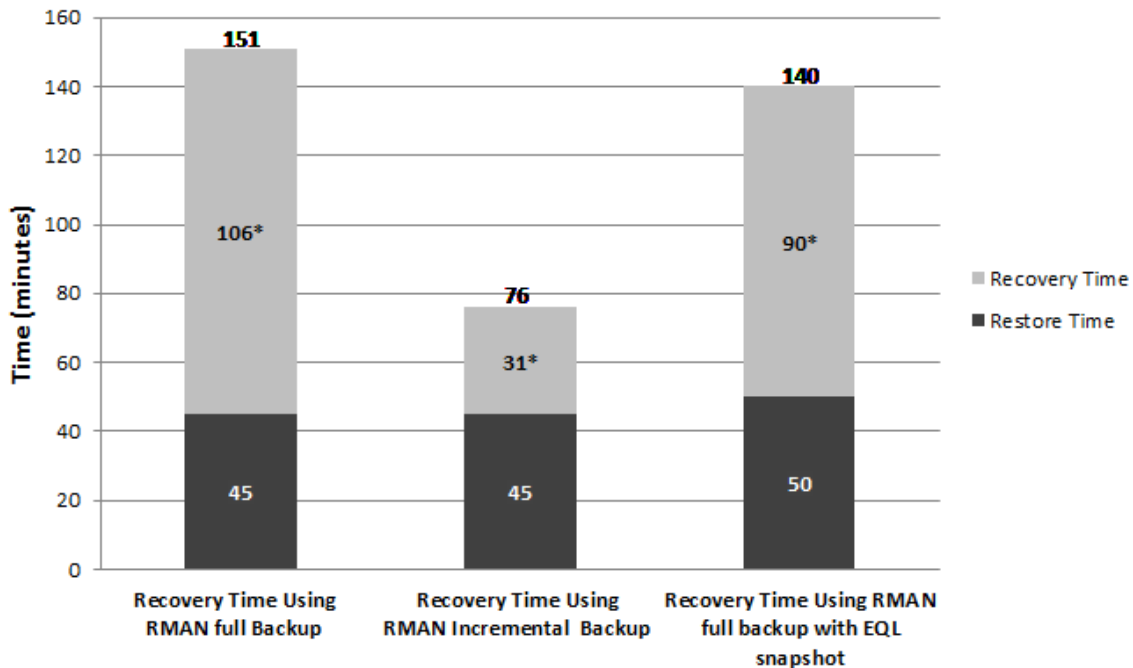

* Time required to complete recovery depends on transaction history since previous backup.

Figure 11 – Recovery time comparison

Point-in-time recovery

Refer back to Figure 9 for a comparison of point-in-time recovery results.

- The database needs to be in FLASHBACK mode for enabling the FLASHBACK DATABASE feature. This introduces additional processing overhead on the database servers as well as storage space requirements for the flashback recovery area.
- The time taken to recover the database to a previous time using Oracle FLASHBACK DATABASE feature was proportional to how far back the database needed to be rolled back and the amount of changes in the transaction history.

- EqualLogic snapshots efficiently met the point-in-time recovery objectives. The Snapshot restore operation was almost instantaneous and the entire recovery process was able to be manually completed within six minutes.
- Restore/recovery time when using EqualLogic snapshots did not change based on the amount of database transactions that need to be replayed, as it would if using Oracle FLASHBACK DATABASE.

7.3 Comparison of backup and recovery methods

Key conclusions based on our test results:

- Oracle’s RMAN tool provides a powerful and efficient way to perform backup and recovery operations. RMAN also causes a significant impact on production database server CPU utilization for the entire duration of backup processing.
- EqualLogic snapshots can be used in conjunction with RMAN to offload the entire backup operation to a dedicated backup server, thereby eliminating the CPU utilization impact on the production database server.
- When using EqualLogic snapshots you can drastically reduce the time to complete point-in-time recovery as compared to using the Oracle FLASHBACK DATABASE.

Table 4 compares RMAN full backup, incremental backup and EqualLogic snapshot based backup.

Table 4 – Comparison of backup methods

Method	DB server impact	Backup Window Time	RTO Impact	RPO Impact
RMAN Full Backup	High	Depends on size of DB and server workload	Depends on size and frequency of backup and size of redo log history	Optimizing RPO amplifies performance impacts on production DB caused by RMAN processing
RMAN Incremental Backup	High	Depends on size of DB, server workload and transaction history	Depends on size and frequency of backups, and redo log history. Usually faster than full backup.	
RMAN Backup Offload using EqualLogic snapshots	Low	Eliminates backup time window impact on production DB servers	Depends on size and frequency of backup and redo log history	Backup offload allows you to optimize RPO with minimal impact on production DB systems

Table 5 compares point-in-time recovery methods when using EqualLogic snapshots vs. Oracle FLASHBACK DATABASE.

Table 5 – Comparison of point-in-time methods

Method	RTO Impact (Refer to Figure 9 in Section 6.3)
FLASHBACK DATABASE	Recovery time depends on transaction history. Can take significantly longer to complete than recovery from EqualLogic snapshots.
EQL Snapshots	Time to recover is very short, and does not depend on transaction history.

Note:

Storage capacity is also impacted by each of the methods described in Table 4 and Table 5. In general, when using EqualLogic snapshots you will need to plan snapshot reserve capacity based on how many snapshots need to be retained and the data change rate on the database volumes from which you are creating snapshots.

8 Best practices for backup and recovery

8.1 Use a Virtualized Database Backup Server

We recommend that you use Dell EqualLogic Snapshots along with Oracle RMAN to reduce performance impact on production database servers (CPU Utilization) and improve the efficiency of backup and recovery operations. The EqualLogic snapshot feature allows you to offload the entire RMAN backup copy operation to a dedicated host system, thus allowing you to free up critical production database server CPU resources for mission-critical tasks.

If using VMware ESX to host database servers, use the Virtual NIC Type and enable jumbo frames

We used the guest OS iSCSI initiators. Virtual NICs were created using the "VMXNET3" type. VMXNET3 type NICs support jumbo frames. Jumbo frames should be enabled on the NICs on the Guest OS and also on the vSwitch used for iSCSI SAN connectivity. Use the following command to verify that jumbo frames are enabled end-to-end from Guest OS to Storage array:

```
ping -s 8900 -M do <Storage_Array_IP>
```

We recommend installing the latest version of VMware tools on the guest OS.

8.2 RMAN backup

The Flash recovery area is a key component that is tightly integrated with Oracle's RMAN utility for performing disk-to-disk backup. The flash recovery area allows DBAs to create a location on the disk where the database backup and recovery-related files can easily be managed. Below are some key best practices when using the RMAN backup utility:

- Separate the flash recovery area from the database volumes (data files and redo log files). During the testing detailed in this paper, the PS6010E array hosting the archive logs and backup data was placed in a different EqualLogic pool.
- The flash recovery area can be configured using lower-cost, high-capacity storage. In our test configuration, the flash recovery area used a PS6010E array consisting of 7.2K SATA drives.
- Distribute the backup I/O across multiple volumes to achieve better performance. We distributed the flashback recovery area across five volumes in the EqualLogic pool.
- Use multiple ASM disks to help distribute the I/O across Oracle ASM disks. During the test suite detailed in this paper, we distributed the backup I/O across five ASM disk groups.

8.3 Snapshot reserve space sizing

Typically, database administrators will keep at least two snapshots per day in order to reduce mean time to recovery (MTTR). Disk consumption by EqualLogic snapshots only grows when data changes in the volume. You should monitor snapshot reserve space utilization. EqualLogic snapshot reserve space utilization will depend on:

- Frequency of snapshots and the number of snapshots that need to be retained
- The rate of data change in the database volumes that retain snapshots

Another key point to consider is that the EqualLogic array automatically creates a snapshot during the restore operation. The array captures the snapshot and copies the original source volume content into this snapshot before the actual restore operation. IT storage administrators may find the automatic creation feature useful since they can analyze the snapshot content to determine the possible root cause of data corruption failure. This feature is also useful for undoing a snapshot restore operation if for some reason the restore operation does not succeed.

8.4 Point-in-time recovery using Oracle FLASHBACK DATABASE

The FLASHBACK DATABASE feature uses a different type of log (flashback logs) for keeping track of database changes. If the flashback feature is enabled, then flashback logs are generated and written sequentially to flash recovery area during normal database operation.

- While enabling the FLASHBACK DATABASE feature, be sure to plan the flash recovery area so that it can accommodate growth of these log files. When we executed the 4000 user TPC-C workload using Quest Benchmark Factory, approximately 30GB of flashback logs were generated every hour.
- The parameter `DB_FLASHBACK_RETENTION_TARGET` specifies the maximum amount of time the database can be rolled back. The flash back recovery area should be able to store all of the flashback recovery logs that can be generated for the period specified by the `DB_FLASHBACK_RETENTION_TARGET` parameter.

8.5 Discovering ORACLE ASM disks on the backup server

ORACLE ASMLIB configured at the OS level on the backup server discovered and listed all of the ASM disks. However, the Oracle ASM database software installer was not able to recognize any of the same ASM disks. Even after we installed the ASM software on the backup server, the ASM disks were discovered at the OS level but the SQL query executed on the ASM instance did not detect any of the ASM disks. As a result, none of the ASM disk groups were mounted on the backup server. Use the following steps to fix this issue:

1. When installing Oracle ASM software on the backup server set `/dev/oracleasm/disks` as the 'Disk discovery path'.
2. In the file `/etc/sysconfig/oracleasm`, set `"parameter asm_diskstring = dev/oracleasm/disks/*"` if it is not currently set.

8.6 Persistent device mapping on the virtualized backup server

Once you mount the snapshot on the backup server you need to re-discover then login to all targets. There is no need to create any persistent device mapping for snapshot targets. Do not modify the `/etc/multipath.conf` file on the backup server. The ASM labels will be automatically discovered once the rescan of Oracle ASM disks is complete. Once the snapshots are mounted, the iSCSI targets can be discovered on the backup server.

8.7 Upgrade Broadcom 57711 driver

There is a documented performance issue with the Broadcom 57711 drivers shipped with ESX 4.1. For maximum performance, upgrade the Broadcom 57711 firmware and driver to the following version:

Firmware : 6.0.1 / Driver : 1.60.50.v41.2

The URL for downloading the Broadcom drivers from VMware is:

http://downloads.vmware.com/d/details/esx41_broadcom_netextremeii_dt/ZHcqYnRlaHRiZHdlZQ

8.8 RMAN configuration parameters

By default, the BACKUP OPTIMIZATION parameter for RMAN is OFF. We enabled backup optimization by executing the following command from the RMAN prompt.

```
RMAN> configure backup optimization on;
```

If backup optimization is enabled, then the RMAN backup command skips backing up any identical files that have been already backed up. This helps to reduce the backup time window.

The other key parameter, RETENTION POLICY TO REDUNDANCY 1, is a default RMAN parameter and specifies how many backups of the data file should be kept. You should set this parameter to the proper number of backups that need to be retained.

Also, it is very important to ensure that the **controlfile autobackup feature** is turned **ON**. This ensures that RMAN automatically performs control file backups and stores them in flash recovery area. Enable this parameter by executing the following command from the RMAN prompt:

```
RMAN> configure controlfile autobackup on;
```

With this parameter enabled RMAN can recover the database even if the current control file, recovery catalog and server parameter files are not accessible. Example 1 below shows the RMAN configuration parameters used in our setup. Modified parameters are highlighted in **bold** faced text.

Example 1 - RMAN configuration parameters

```
RMAN> show all;
using target database control file instead of recovery catalog
RMAN configuration parameters for database with db_unique_name SIEORADB are:
CONFIGURE RETENTION POLICY TO REDUNDANCY 1; # default
CONFIGURE BACKUP OPTIMIZATION ON;
CONFIGURE DEFAULT DEVICE TYPE TO DISK; # default
CONFIGURE CONTROLFILE AUTOBACKUP ON;
CONFIGURE CONTROLFILE AUTOBACKUP FORMAT FOR DEVICE TYPE DISK TO '%F'; # default
CONFIGURE DEVICE TYPE DISK PARALLELISM 1 BACKUP TYPE TO BACKUPSET; # default
CONFIGURE DATAFILE BACKUP COPIES FOR DEVICE TYPE DISK TO 1; # default
CONFIGURE ARCHIVELOG BACKUP COPIES FOR DEVICE TYPE DISK TO 1; # default
CONFIGURE MAXSETSIZE TO UNLIMITED; # default
CONFIGURE ENCRYPTION FOR DATABASE OFF; # default
CONFIGURE ENCRYPTION ALGORITHM 'AES128'; # default
CONFIGURE COMPRESSION ALGORITHM 'BASIC' AS OF RELEASE 'DEFAULT' OPTIMIZE FOR
LOAD TRUE ; # default
CONFIGURE ARCHIVELOG DELETION POLICY TO NONE; # default
CONFIGURE SNAPSHOT CONTROLFILE NAME TO
'/u01/app/oracle/product/11.2.0/dbhome_1/dbs/snapcf_sieoradb1.f'; # default
```

Appendix A Test system component details

This section contains an overview of both the hardware and software configurations used throughout the testing described in this document.

Table 6 – Test Configuration Hardware Components

Test Configuration – Hardware Components	
Oracle Database Servers	<p>2 x Dell PowerEdge R710 Servers:</p> <ul style="list-style-type: none"> • RHEL 5.5 OS • BIOS Version: 2.1.15 • 2 x Quad Core Intel® Xeon® X5570 Processors • 64 GB RAM, 8M Cache, 2.93 GHz • 2 x 146GB 10K SAS internal disk drives • Broadcom 5709 1GbE quad-port NIC (LAN on motherboard) • 2 x Broadcom NetXtreme II 57711 10GbE NIC, Dual-Port – Driver 14.2.3, A03
Oracle Database Backup server	<p>One virtual machine was created on this ESX server. RHEL 5.5 OS/ Oracle database software and Oracle ASM libraries were installed.</p> <p>1 x Dell PowerEdge R710 Server:</p> <ul style="list-style-type: none"> • ESX 4.1 OS • BIOS Version: 2.1.15 • 2 x Quad Core Intel® Xeon® X5570 Processors • 64 GB RAM, 8M Cache, 2.93 GHz • 2 x 146GB 10K SAS internal disk drives • Broadcom 5709 1GbE quad-port NIC (LAN on motherboard) • 2 x Broadcom NetXtreme II 57711 10GbE NIC, Dual-Port – Driver 14.2.3, A03
I/O Workload Generators	<p>Eight Windows virtual machines were created on these ESX servers, each running Quest Benchmark factory.</p> <p>2 x Dell PowerEdge R610 Servers:</p> <ul style="list-style-type: none"> • BIOS Version: 2.1.15 • Quad Core Intel® Xeon® X5570 Processor • 64 GB RAM, 8M Cache, 2.93 GHz • 2 x 146GB 10K SAS internal disk drives • Broadcom 5709 1GbE quad-port NIC (LAN on motherboard) – Driver 14.2.3, A03
Network	<p>2 x Dell PowerConnect 6248 1Gb Ethernet Switch</p> <ul style="list-style-type: none"> • Firmware: 3.2.0.9 <p>2 x Dell PowerConnect 8024F 10Gb Ethernet Switch</p> <ul style="list-style-type: none"> • Firmware: 3.1.4.5
Storage	<p>1 x Dell EqualLogic PS6010XV:</p> <ul style="list-style-type: none"> • 14 x 300GB 15K RPM SAS disk drives as RAID 10, with two hot spare disks • 10GbE dual-port controller running firmware version 5.0.2 (R138185) <p>1 x Dell EqualLogic PS6010E:</p> <ul style="list-style-type: none"> • 14 x 700GB SATA drives as RAID 50, with two hot spare disks • 10GbE dual-port controller running firmware version 5.0.2 (R138185)

Table 7 – Test Configuration Software Components

Test Configuration – Software Components	
Database Servers	Red Hat Enterprise Linux 5.5 <ul style="list-style-type: none"> • iSCSI software initiator: 6.2.0.871-0.16.el5 • MPIO Enabled: v0.4.7 Oracle Database 11g R2 Enterprise Edition <ul style="list-style-type: none"> • Two-Node Oracle RAC database. • ASM for Clusterware and Database
Virtualized Backup Server	Red Hat Enterprise Linux 5.5 <ul style="list-style-type: none"> • iSCSI software initiator: 6.2.0.871-0.16.el5 • MPIO Enabled: v0.4.7 Oracle Database 11g R2 Enterprise Edition <ul style="list-style-type: none"> • Oracle Single instance database software • ASM for single instance database
Virtualization Server	VMware vSphere ESX version 4.1 <ul style="list-style-type: none"> • Bare metal hypervisor directly installed on R610 servers • Four guest VMs on each ESX server • Managed by vCenter
I/O Workload Generators	8 x Windows Server 2008 R2 Enterprise Edition Workload generators (running within VMs): <ul style="list-style-type: none"> • Quest Benchmark Factory 6.1.1 • 3 agents from each VM • Oracle 11g R2 client installed
Monitoring Tools	EqualLogic SAN Headquarters version 2.0 Oracle OS Watcher utility (installed on database servers) Oracle 11g R2 Automatic Workload Repository (AWR)

Appendix B Automation of snapshot-based backup

In Example 2 we provide the source for the expect script used to automate parts of the user managed backup method presented in Section 5. This expect script performs three tasks:

1. Place the database in hot backup mode
2. Create the snapshot collection on the EqualLogic storage array
3. Take the database out of hot backup mode

Example 2 – User managed backup automation script

```
#!/usr/bin/expect -f

set VOL_COL [ lindex $argv 1 ]
set SNAP_NAME [ lindex $argv 2 ]
# Check for at least 1 arguments.
#
if { [ llength $argv ] < 3 } {
    puts "Usage: $argv0 \"Array IP Address\" \"Volume Collection\" \"Snapshot
Name\" \" \"
    exit
}
set timeout 30
# Put the database in hot backup mode"
spawn sqlplus / as sysdba;
expect "SQL>"
send "alter database begin backup;\r"
expect "SQL>"
send "exit\r"
expect "*$"
spawn telnet [ lindex $argv 0 ]
set timeout 30
expect "login:"
send "grpadmin\r"
expect "Password:"
sleep 1
send "eq1\r"

expect {
    timeout {
        return 1
    }
    "Login incorrect" {
        return 1
    }
    "> " {
        sleep 1
        send "snapcol create $VOL_COL $SNAP_NAME description test\r"
        expect "> " {
            send "logout\r"
        }
    }
}
```

```
    }  
  }  
}  
  
expect "$* " "  
send "\r"  
  
# Take the database out of hot backup mode"  
spawn sqlplus / as sysdba;  
expect "SQL>"  
send "alter database end backup;\r"  
expect "SQL>"  
send "alter system archive log current;\r"  
expect "SQL>"  
send "exit\r"  
exit
```

Related publications

The following Dell publications are referenced in this document or are recommended sources for additional information.

- *Dell EqualLogic PS Series Network Performance Guidelines*
<http://www.equallogic.com/resourcecenter/assetview.aspx?id=5229>
- *Sizing and Best Practices for Deploying Oracle 11g Transaction Processing Databases on Dell EqualLogic Storage*
<http://www.delltechcenter.com/page/Sizing+and+Best+Practices+for+Oracle+11g+OLTP+on+EqualLogic>
- *EqualLogic Configuration Guide*
<http://www.delltechcenter.com/page/EqualLogic+Configuration+Guide>
- *Oracle 11g Database Concepts*
http://download.oracle.com/docs/cd/B28359_01/server.111/b28318/toc.htm
- *Oracle Database Backup and Recovery Reference*
http://download.oracle.com/docs/cd/E11882_01/backup.112/e10643.pdf
- *Oracle Database Backup and Recovery User's Guide*
http://download.oracle.com/docs/cd/E11882_01/backup.112/e10642.pdf
- *Backup and Recovery of Oracle Database on Dell EqualLogic PS Series iSCSI Storage*
<http://www.equallogic.com/resourcecenter/assetview.aspx?id=7801>



THIS WHITE PAPER IS FOR INFORMATIONAL PURPOSES ONLY, AND MAY CONTAIN
TYPOGRAPHICAL ERRORS AND TECHNICAL INACCURACIES. THE CONTENT IS PROVIDED AS
IS, WITHOUT EXPRESS OR IMPLIED WARRANTIES OF ANY KIND.