

Dell™ PowerEdge™ R910

Hardware Owner's Manual

Regulatory Model: E06S Series

Regulatory Type: E06S001



Notes, Cautions, and Warnings



NOTE: A NOTE indicates important information that helps you make better use of your computer.



CAUTION: A CAUTION indicates potential damage to hardware or loss of data if instructions are not followed.



WARNING: A WARNING indicates a potential for property damage, personal injury, or death.

Information in this document is subject to change without notice.

© 2010–2012 Dell Inc. All rights reserved.

Reproduction of these materials in any manner whatsoever without the written permission of Dell Inc. is strictly forbidden.

Trademarks used in this text: *Dell*, the *DELL* logo, and *PowerEdge* are trademarks of Dell Inc. *Microsoft*, *Windows*, and *Windows Server* are either trademarks or registered trademarks of Microsoft Corporation in the United States and/or other countries.

Other trademarks and trade names may be used in this document to refer to either the entities claiming the marks and names or their products. Dell Inc. disclaims any proprietary interest in trademarks and trade names other than its own.

Regulatory Model: E06S Series

Regulatory Type: E06S001

October 2012

Rev. A02

Contents

1	About Your System	11
	Accessing System Features During Startup	11
	Front-Panel Features and Indicators	12
	LCD Panel Features	14
	Home Screen	15
	Setup Menu	16
	View Menu	17
	Hard-Drive Indicator Patterns	18
	Back-Panel Features and Indicators	19
	Guidelines for Connecting External Devices	21
	NIC Indicator Codes	21
	Power Indicator Codes	22
	LCD Status Messages	23
	Viewing Status Messages	23
	Removing LCD Status Messages	24
	System Messages	41
	Warning Messages	60
	Diagnostics Messages	60
	Alert Messages	60

Other Information You May Need	60
2 Using the System Setup Program and UEFI Boot Manager	63
Choosing the System Boot Mode	63
Entering the System Setup Program	64
Responding to Error Messages	64
Using the System Setup Program Navigation Keys	64
System Setup Options	65
Main Screen	65
Memory Settings Screen	67
Processor Settings Screen	68
SATA Settings Screen.	69
Boot Settings Screen	69
Integrated Devices Screen	70
PCI IRQ Assignments Screen	71
Serial Communication Screen	72
Embedded Server Management Screen	73
Power Management Screen	73
System Security Screen	74
Exit Screen	76
Entering the UEFI Boot Manager.	76
Using the UEFI Boot Manager Navigation Keys	77
UEFI Boot Manager Screen.	77
UEFI Boot Settings Screen	78
System Utilities Screen	78
System and Setup Password Features.	79
Using the System Password	79
Using the Setup Password	81

Embedded System Management	82
iDRAC Configuration Utility	83
Entering the iDRAC Configuration Utility	83
3 Installing System Components	85
Recommended Tools.	85
Inside the System	85
Front Bezel (Optional)	87
Removing the Front Bezel	87
Installing the Front Bezel	87
System Identification Panel	88
Removing the System Identification Panel	88
Installing the System Identification Panel	89
Opening and Closing the System	89
Opening the System	89
Closing the System	90
System Memory	91
General Memory Module Installation Guidelines.	92
Removing a Memory-Riser Blank	99
Installing a Memory-Riser Blank	100
Removing a Memory Riser	100
Installing a Memory Riser	101
Installing Memory Modules	102
Removing Memory Modules	105
Removing the Memory-Riser Guide	106
Installing the Memory-Riser Guide.	107

Hard Drives	107
Removing a Hard-Drive Blank	108
Installing a Hard-Drive Blank	108
Removing a Hard Drive	109
Installing a Hard Drive	110
Removing a Hard Drive From a Hard-Drive Carrier	112
Installing a Hard Drive Into a Drive Carrier	113
Optical Drive	113
Removing an Optical Drive	113
Installing an Optical Drive	115
Cooling Fans	116
Removing a Cooling Fan	116
Installing a Cooling Fan	117
Removing the Cooling Fan Assembly	118
Installing the Cooling Fan Assembly	120
Internal USB Memory Key	120
Integrated NIC Hardware Key	123
Expansion Cards and Expansion-Card Riser	124
Expansion Card Installation Guidelines	124
Installing an Expansion Card	126
Removing an Expansion Card	128
Installing an Expansion-Card Riser	129
Removing an Expansion-Card Riser	133
I/O Card	134
Removing the I/O Card	134
Installing the I/O Card	135

iDRAC6 Enterprise Card (Optional)	136
Installing an iDRAC6 Enterprise Card	136
Removing an iDRAC6 Enterprise Card	138
VFlash Media (Optional)	139
Installing a VFlash Media Card	139
Removing a VFlash Media Card	139
Internal Dual SD Module (Optional)	139
Removing the Internal Dual SD Module	139
Installing the Internal Dual SD Module.	141
Internal SD Card (Optional)	142
Installing an Internal SD Card	142
Removing an Internal SD Card	142
Integrated Storage Controller Card	143
Removing the Integrated Storage Controller Card	143
Installing the Integrated Storage Controller Card	145
RAID Battery	146
Removing a RAID Battery.	146
Installing the RAID Battery	147
Processors	148
Removing a Processor	148
Installing a Processor	152
Power Supplies	154
Removing a Power Supply	155
Installing a Power Supply	156
Removing the Power Supply Blank.	157
Installing the Power Supply Blank	157

System Battery	157
Replacing the System Battery	157
SAS Backplane	159
Removing the SAS Backplane	159
Installing the SAS Backplane.	161
Power Distribution Board	161
Removing the Power Distribution Board	161
Replacing the Power Distribution Board	163
Control Panel Assembly	163
Removing the Control Panel Display Module.	163
Installing the Control Panel Display Module	164
Removing the Control Panel Board	166
Installing the Control Panel Board	167
System Board	168
Removing the System Board	168
Installing the System Board.	170
4 Troubleshooting Your System	173
Safety First—For You and Your System	173
Troubleshooting System Startup Failure.	173
Troubleshooting External Connections	173
Troubleshooting the Video Subsystem.	174
Troubleshooting a USB Device	174
Troubleshooting a Serial I/O Device.	175
Troubleshooting a NIC	175

Troubleshooting a Wet System	176
Troubleshooting a Damaged System	177
Troubleshooting the System Battery.	178
Troubleshooting Power Supplies	179
Troubleshooting System Cooling Problems	180
Troubleshooting a Fan	180
Troubleshooting System Memory	181
Troubleshooting an Internal USB Key	183
Troubleshooting an Internal SD Card	184
Troubleshooting an Optical Drive	185
Troubleshooting a Tape Backup Unit	186
Troubleshooting a Hard Drive	186
Troubleshooting a Storage Controller.	187
Troubleshooting Expansion Cards.	189
Troubleshooting the Processors.	190
5 Running the System Diagnostics.	193
Using Online Diagnostics	193
Embedded System Diagnostics Features	193
When to Use the Embedded System Diagnostics	194
Running the Embedded System Diagnostics	194
System Diagnostics Testing Options	194

	Using the Custom Test Options	195
	Selecting Devices for Testing	195
	Selecting Diagnostics Options	195
	Viewing Information and Results	196
6	Jumpers and Connectors	197
	System Board Jumper	197
	System Board Connectors	198
	SAS Backplane Board Connectors	200
	Disabling a Forgotten Password	201
7	Getting Help	203
	Contacting Dell	203
	Index	205

About Your System

Accessing System Features During Startup

The following keystrokes provide access to system features during startup.



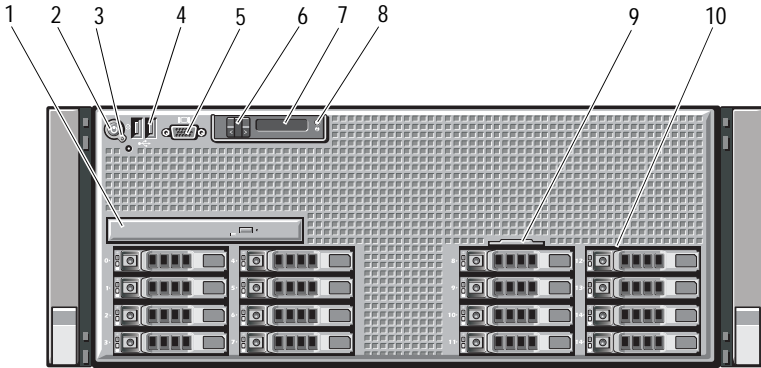

Keystroke	Description
< F2 >	Enters the System Setup program. See "Using the System Setup Program and UEFI Boot Manager" on page 63.
< F10 >	Enters System Services, which opens the Lifecycle Controller. The Lifecycle Controller allows you to access utilities such as embedded system diagnostics. For more information, see the Lifecycle Controller documentation.
< F11 >	Enters the BIOS Boot Manager or the UEFI Boot Manager, depending on the system's boot configuration. See "Using the System Setup Program and UEFI Boot Manager" on page 63.
< F12 >	Starts PXE boot.
< Ctrl > < E >	Enters the iDRAC Configuration Utility, which allows access to the System Event Log (SEL) and configuration of remote access to the system. For more information, see the iDRAC user documentation.
< Ctrl > < C >	Enters the SAS Configuration Utility. For more information, see the SAS adapter documentation.
< Ctrl > < R >	Enters the PERC configuration utility. For more information, see the PERC card documentation
< Ctrl > < S >	Enters the utility to configure NIC settings for PXE boot. For more information, see the documentation for your integrated NIC.

Front-Panel Features and Indicators

Figure 1-1. Front-Panel Features and Indicators



Item	Indicator, Button, or Connector	Icon	Description
1	Optical drive (optional)		One optional slim-line SATA DVD-ROM drive or DVD-RW drive. NOTE: DVD devices are data only.
2	Power-on indicator, power button		The power-on indicator lights when the system power is on. The power button controls the DC power supply output to the system. When the system bezel is installed, the power button is not accessible. NOTE: When powering on the system, the video monitor can take from several seconds to over two minutes to display an image, depending on the amount of memory installed in the system. NOTE: On ACPI-compliant operating systems, turning off the system using the power button causes the system to perform a graceful shutdown before power to the system is turned off.

Item	Indicator, Button, or Connector	Icon	Description
3	NMI button		<p>Used to troubleshoot software and device driver errors when using certain operating systems. This button can be pressed using the end of a paper clip.</p> <p>Use this button only if directed to do so by qualified support personnel or by the operating system's documentation.</p>
4	USB connectors (2)		Connect USB devices to the system. The ports are USB 2.0-compliant.
5	Video connector		Connects a monitor to the system.
6	LCD menu buttons		Allows you to navigate the control panel LCD menu.
7	LCD panel		<p>Provides system ID, status information, and system error messages.</p> <p>The LCD lights blue during normal system operation. The LCD lights amber when the system needs attention, and the LCD panel displays an error code followed by descriptive text.</p> <p>NOTE: If the system is connected to AC power and an error has been detected, the LCD lights amber regardless of whether the system has been powered on.</p>
8	System identification button		The identification buttons on the front and back panels can be used to locate a particular system within a rack. When one of these buttons is pushed, the LCD panel on the front and the blue system status indicator on the back blink until one of the buttons is pushed again.

Item	Indicator, Button, or Connector	Icon	Description
9	System identification panel		A slide-out panel for system information including the Express Service tag, embedded NIC MAC address, and iDRAC6 Enterprise card MAC address. Space is provided for an additional label.
10	Hard drives		Up to sixteen 2.5-inch, external hot-swappable SAS or SSD hard drives. NOTE: Only one SATA drive is supported on the x4 backplane. SAS and SATA hard disks on the same backplane cannot be combined into a single virtual disk. x16 backplanes do not support SATA drives.

LCD Panel Features

The system's LCD panel provides system information and status and error messages to signify when the system is operating correctly or when the system needs attention. See "LCD Status Messages" on page 23 for information about specific status codes.

The LCD backlight lights blue during normal operating conditions and lights amber to indicate an error condition. When the system is in standby mode, the LCD backlight is off and can be turned on by pressing either the Select, Left or Right button on the LCD panel. The LCD backlight will remain off if LCD messaging is turned off through the iDRAC utility, the LCD panel, or other tools.

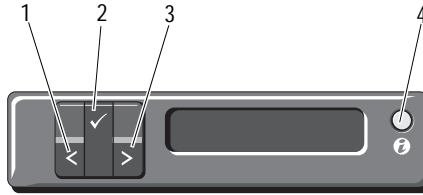

Figure 1-2. LCD Panel Features



Item	Buttons	Description
1	Left	Moves the cursor back in one-step increments.
2	Select	Selects the menu item highlighted by the cursor.
3	Right	Moves the cursor forward in one-step increments. During message scrolling: <ul style="list-style-type: none">• Press once to increase scrolling speed.• Press again to stop.• Press again to return to default scrolling speed.• Press again to repeat the cycle.
4	System identification	Turns the system ID mode on (LCD panel flashes blue) and off. Press quickly to toggle the system ID on and off. If the system hangs during POST, press and hold the system ID button for more than five seconds to enter BIOS Progress mode.

Home Screen

The Home screen displays user-configurable information about the system. This screen is displayed during normal system operation when there are no status messages or errors present. When the system is in standby mode, the LCD backlight will turn off after five minutes of inactivity if there are no error messages. Press one of the three navigation buttons (Select, Left, or Right) to view the Home screen.

To navigate to the Home screen from another menu, continue to select the up arrow  until the Home icon  is displayed, and then select the Home icon.

From the Home screen, press the **Select** button to enter the main menu. See the following tables for information on the **Setup** and **View** submenus.

Setup Menu



NOTE: When you select an option in the **Setup** menu, you must confirm the option before proceeding to the next action.

Option	Description
DRAC	Select DHCP or Static IP to configure the network mode. If Static IP is selected, the available fields are IP , Subnet (Sub) , and Gateway (Gtw) . Select Setup DNS to enable DNS and to view domain addresses. Two separate DNS entries are available.
Set error	Select SEL to display LCD error messages in a format that matches the IPMI description in the SEL. This can be useful when trying to match an LCD message with an SEL entry. Select Simple to display LCD error messages in a simplified user-friendly description. See "LCD Status Messages" on page 23 for a list of messages in this format.
Set home	Select the default information to be displayed on the LCD Home screen. See "View Menu" on page 17 to see the options and option items that can be set as the default on the Home screen.

View Menu

Option	Description
DRAC IP	Displays the IPv4 or IPv6 addresses for the iDRAC6. Addresses include DNS (Primary and Secondary) , Gateway , IP , and Subnet (IPv6 does not have Subnet).
MAC	Displays the MAC addresses for DRAC , iSCSI<i>n</i> , or NET<i>n</i> .
Name	Displays the name of the Host , Model , or User String for the system.
Number	Displays the Asset tag or the Service tag for the system.
Power	Displays the power output of the system in BTU/hr or Watts. The display format can be configured in the Set home submenu of the Setup menu. See "Setup Menu" on page 16.
Temperature	Displays the temperature of the system in Celsius or Fahrenheit. The display format can be configured in the Set home submenu of the Setup menu. See "Setup Menu" on page 16.

Hard-Drive Indicator Patterns

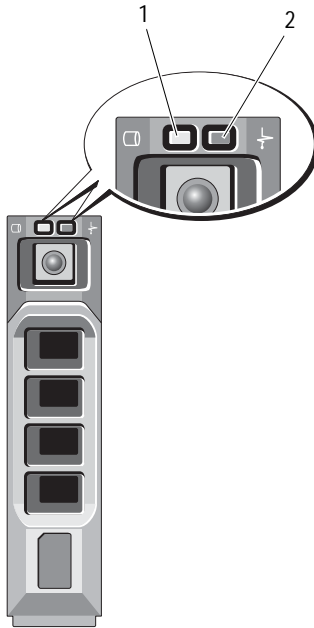

- 1 hard-drive activity indicator (green)
- 2 hard-drive status indicator (green and amber)

Drive-Status Indicator Pattern (RAID Only)	Condition
Blinks green two times per second	Identify drive/preparing for removal
Off	Drive ready for insertion or removal NOTE: The drive status indicator remains off until all hard drives are initialized after system power is applied. Drives are not ready for insertion or removal during this time.
Blinks green, amber, and off	Drive predicted failure





Drive-Status Indicator Pattern (RAID Only)	Condition
Blinks amber four times per second	Drive failed
Blinks green slowly	Drive rebuilding
Steady green	Drive online
Blinks green three seconds, amber three seconds, and off six seconds	Rebuild aborted

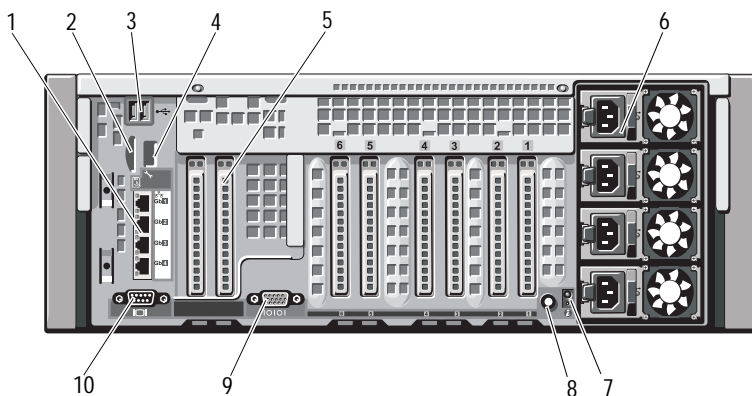

Back-Panel Features and Indicators

Figure 1-3. Back-Panel Features and Indicators



Item	Indicator, Button, or Connector	Icon	Description
1	Ethernet or SFP+ connectors		Depending on the configuration, your system may have either a 1 GbE I/O riser or a 10 Gb I/O riser. A 1 GbE I/O riser consists of four Ethernet connectors and a 10 Gb I/O riser consists of two SFP+ and two Ethernet connectors.

Item	Indicator, Button, or Connector	Icon	Description
2	VFlash media slot (optional)		Connects an external SD memory card for the optional iDRAC6 Enterprise card.
3	USB connectors (2)		Connect USB devices to the system. The ports are USB 2.0-compliant.
4	iDRAC6 Enterprise port (optional)		Dedicated management port for the optional iDRAC6 Enterprise card.
5	PCIe expansion card slots (7)		<p>PCI Express Generation 1 and Generation 2</p> <p>Slot 1: PCIe x4 Gen2 half-length, full height</p> <p>Slot 2–4: PCIe x8 Gen2 half-length, full height</p> <p>Slot 5: PCIe x4 Gen1 half-length, full height</p> <p>Slot 6: PCIe x8 Gen2 half-length, full height</p> <p>Slot 7: PCIe x16 Gen2 half-length, half height</p> <p>NOTE: Slot 7 can be expanded to four additional PCIe x4 Gen2 low profile slots using an optional PCIe expansion riser.</p>
6	Power supplies (4)		1100 W or 750 W
7	System identification connector		Connects the optional system status indicator assembly through the optional cable management arm.
8	System identification button		The identification buttons on the front and back panels can be used to locate a particular system within a rack. When one of these buttons is pushed, the LCD panel on the front and the blue system status indicator on the back blink until one of the buttons is pushed again.

Item	Indicator, Button, or Connector	Icon	Description
9	Serial connector		Connects a serial device to the system.
10	Video connector		Connects a VGA display to the system.

Guidelines for Connecting External Devices

- Turn off power to the system and external devices before attaching a new external device. Turn on any external devices before turning on the system (unless the documentation for the device specifies otherwise).
- Ensure that the appropriate driver for the attached device has been installed on the system.
- If necessary to enable ports on your system, use the "Using the System Setup Program and UEFI Boot Manager" on page 63.

NIC Indicator Codes

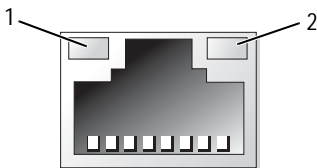

1 link indicator

2 activity indicator

Indicator	Indicator Code
Link and activity indicators are off	The NIC is not connected to the network.
Link indicator is green	The NIC is connected to a valid network link at 1000 Mbps.

Indicator	Indicator Code
Link indicator is amber	The NIC is connected to a valid network link at 10/100 Mbps.
Activity indicator is green blinking	Network data is being sent or received.

Power Indicator Codes

The power supplies have indicators that show whether power is present or whether a power fault has occurred.

- Not lit — AC power is not connected.
- Green — In standby mode, a green light indicates that a valid AC source is connected to the power supply and that the power supply is operational. When the system is on, a green light also indicates that the power supply is providing DC power to the system.
- Amber — Indicates a problem with the power supply.
- Alternating green and amber — When hot-adding a power supply, this indicates that the power supply is mismatched with the other power supply (a high output power supply and an energy smart power supply are installed in the same system). Replace the power supply that has the flashing indicator with a power supply that matches the capacity of the other installed power supply.

 **CAUTION:** When correcting a power supply mismatch, replace only the power supply with the flashing indicator. Swapping the opposite power supply to make a matched pair can result in an error condition and unexpected system shutdown. To change from a High Output configuration to an Energy Smart configuration or vice versa, you must power down the system.

Figure 1-4. Power Supply Status Indicator



1 Velcro strap

2 power supply status indicator

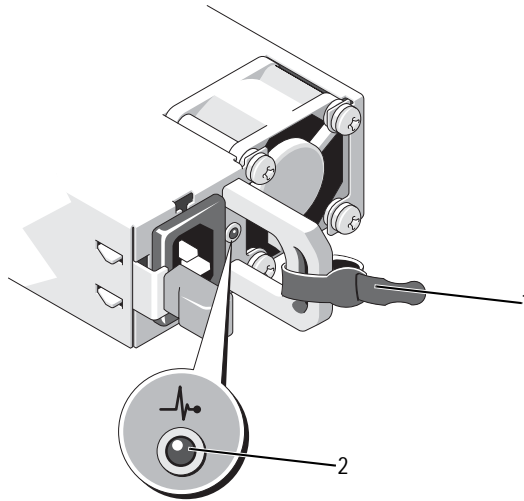
LCD Status Messages

The LCD messages consist of brief text messages that refer to events recorded in the System Event Log (SEL). For information on the SEL and configuring system management settings, see the systems management software documentation.

 **NOTE:** If your system fails to boot, press the System ID button for at least 5 seconds until an error code appears on the LCD. Record the code, then see "Getting Help" on page 203.

Viewing Status Messages

If a system error occurs, the LCD screen will turn amber. Press the **Select** button to view the list of errors or status messages. Use the left and right buttons to highlight an error number, and press **Select** to view the error.

Removing LCD Status Messages

For faults associated with sensors, such as temperature, voltage, fans, and so on, the LCD message is automatically removed when that sensor returns to a normal state. For other faults, you must take action to remove the message from the display:

- Clear the SEL — You can perform this task remotely, but you will lose the event history for the system.
- Power cycle — Turn off the system and disconnect it from the electrical outlet; wait approximately 10 seconds, reconnect the power cable, and restart the system.



NOTE: The following LCD status messages are displayed in the simple format. See "Setup Menu" on page 16 to select the format in which the messages are displayed.

Table 1-1. LCD Status Messages

Code	Text	Causes	Corrective Actions
E1000	Failsafe voltage error. Contact support.	Check the SEL for critical failure events.	Remove AC power to the system for 10 seconds and restart the system. If the problem persists, see "Getting Help" on page 203.
E1114	Ambient Temp exceeds allowed range.	Ambient temperature has reached a point outside of the allowed range.	See "Troubleshooting System Cooling Problems" on page 180.
E1116	Memory disabled, temp above range. Power cycle AC.	Memory has exceeded allowable temperature and has been disabled to prevent damage to the components.	Remove AC power to the system for 10 seconds and restart the system. See "Troubleshooting System Cooling Problems" on page 180. If the problem persists, see "Getting Help" on page 203.

Code	Text	Causes	Corrective Actions
E1119	Chipset # temp out of range. Check motherboard heatsinks.	Chipset temperature has reached a point outside of the allowed range.	See "Troubleshooting System Cooling Problems" on page 180.
E1120	CPU VCORE Temp: "CPU VCORE Regulator temp exceeding range. Check fans".	The regulator temperature has reached a point outside of the allowed range.	See "Troubleshooting System Cooling Problems" on page 180.
E1121	CPU VCACHE Temp: "CPU VCACHE Regulator temp exceeding range. Check fans".	The regulator temperature has reached a point outside of the allowed range.	See "Troubleshooting System Cooling Problems" on page 180.
E1122	Mem VR Temp : "Mem Voltage Regulator temp exceeding range. Check fans".	The regulator temperature has reached a point outside of the allowed range.	See "Troubleshooting System Cooling Problems" on page 180.
E1210	Motherboard battery failure. Check battery.	CMOS battery is missing or the voltage is outside of the allowable range.	See "Troubleshooting the System Battery" on page 178.

Code	Text	Causes	Corrective Actions
E1211	RAID Controller battery failure. Check battery.	RAID battery is either missing, bad, or unable to recharge due to thermal issues.	Reseat the RAID battery connector. See "Installing the RAID Battery" on page 146 and "Troubleshooting System Cooling Problems" on page 180.
E1216	3.3V Regulator failure. Reseat PCIe cards.	3.3V voltage regulator failed.	Remove and reseat the PCIe expansion cards. If the problem persists, see "Troubleshooting Expansion Cards" on page 189.
E1219	Disk Backplane power failure. Check BP power cable.	Storage backplane voltage regulator has failed.	Remove and reseat the backplane. If the problem persists, see "Getting Help" on page 203.
E1222	CPU # VCACHE Regulator failure. Contact support.	Processor voltage regulator failed.	Reseat the processor(s). See "Troubleshooting the Processors" on page 190. If the problem persists, see "Getting Help" on page 203.
E122C	CPU Power Fault. Power cycle AC.	A power fault was detected when powering up the processor(s).	Remove AC power to the system for 10 seconds and restart the system. If the problem persists, see "Getting Help" on page 203.
E122E	On-board regulator failed. Call support.	One of the on-board voltage regulators failed.	Remove AC power to the system for 10 seconds and restart the system. If the problem persists, see "Getting Help" on page 203.

Code	Text	Causes	Corrective Actions
E1233	IO Riser power failure. Reseat IO Riser.	IO riser voltage regulator failed.	Reseat the I/O riser. If the problem persists, see "Getting Help" on page 203.
E1234	Memory Riser # power failure. Reseat riser and DIMMs.	Memory riser voltage regulator failed.	Reseat the memory riser. If the problem persists, see "Getting Help" on page 203.
E1243	CPU # VCORE Regulator failure. Contact Support.	Processor voltage regulator failed.	Reseat the processor. See "Troubleshooting the Processors" on page 190. If the problem persists, see "Getting Help" on page 203.
E1244	Embedded 10Gb NICs disabled. Check or add PSUs.	Insufficient standby power for 10 Gb embedded NICs.	Reseat the power supplies. See "Troubleshooting Power Supplies" on page 179. If the problem persists, see "Getting Help" on page 203.
E1245	CPU # VIO Regulator failure. Contact support.	Processor voltage regulator failed.	Reseat the processor. See "Troubleshooting the Processors" on page 190. If the problem persists, see "Getting Help" on page 203.
E1310	Fan ## RPM exceeding range. Check fan.	RPM of specified fan is outside of the intended operating range.	See "Troubleshooting System Cooling Problems" on page 180.

Code	Text	Causes	Corrective Actions
E1313	Fan redundancy lost. Check fans.	The system is no longer fan redundant. Another fan failure would put the system at risk of over-heating.	Check LCD for additional scrolling messages. See "Troubleshooting a Fan" on page 180.
E1314	Critical system cooling loss. Check fans.	All fans have been removed from system.	Ensure that the fans are properly installed. See "Troubleshooting a Fan" on page 180.
E1410	System Fatal Error detected.	A fatal system error has been detected.	Check LCD for additional scrolling messages. Remove AC power to the system for 10 seconds and restart the system. If the problem persists, see "Getting Help" on page 203.
E1414	CPU # temp exceeding range. Check CPU heatsink.	Specified processor is out of acceptable temperature range.	Ensure that the processor heat sinks are properly installed. See "Troubleshooting the Processors" on page 190 and "Troubleshooting System Cooling Problems" on page 180.
E1418	CPU # not detected. Check CPU is seated properly.	Specified processor is missing or bad, and the system is in an unsupported configuration.	Ensure that the specified processor is properly installed. See "Troubleshooting the Processors" on page 190.
E141C	Unsupported CPU configuration. Check CPU or BIOS revision.	Processors are in an unsupported configuration.	Ensure that your processors match and conform to the type described in the processor technical specifications outlined in your system's <i>Getting Started Guide</i> .

Code	Text	Causes	Corrective Actions
E141F	CPU # protocol error. Power cycle AC.	The system BIOS reported a processor protocol error.	Remove AC power to the system for 10 seconds and restart the system. If the problem persists, see "Getting Help" on page 203.
E1420	CPU Bus parity error. Power cycle AC.	The system BIOS reported a processor bus parity error.	Remove AC power to the system for 10 seconds and restart the system. If the problem persists, see "Getting Help" on page 203.
E1421	CPU # initializati on error. Power cycle AC.	The system BIOS reported a processor initialization error.	Remove AC power to the system for 10 seconds and restart the system. If the problem persists, see "Getting Help" on page 203.
E1422	CPU # machine check error. Power cycle AC.	The system BIOS reported a machine check error.	Remove AC power to the system for 10 seconds and restart the system. If the problem persists, see "Getting Help" on page 203.
E1610	Power Supply # (### W) missing. Check power supply.	Specified power supply was removed or is missing from the system.	See "Troubleshooting Power Supplies" on page 179.
E1614	Power Supply # (### W) error. Check power supply.	Specified power supply failed.	See "Troubleshooting Power Supplies" on page 179.

Code	Text	Causes	Corrective Actions
E1618	Predictive failure on Power Supply # (### W). Check PSU.	A power supply fan failure, an over-temperature condition, or power supply communication error has caused the predictive warning of an impending power supply failure.	See "Troubleshooting Power Supplies" on page 179.
E161C	Power Supply # (### W) lost AC power. Check PSU cables.	Specified power supply is attached to the system, but it has lost its AC input.	Check the AC power source for the specified power supply. If the problem persists, see "Troubleshooting Power Supplies" on page 179.
E1620	Power Supply # (### W) AC power error. Check PSU cables.	Specified power supply's AC input is outside of the allowable range.	Check the AC power source for the specified power supply. If the problem persists, see "Troubleshooting Power Supplies" on page 179.
E1624	Lost power supply redundancy. Check PSU cables.	The power supply subsystem is no longer redundant. If the remaining power supply fails, the system will shut down.	See "Troubleshooting Power Supplies" on page 179.
E1626	Power Supply Mismatch. PSU1 = ### W, PSU2 = ### W.	The power supplies in the system are not the same wattage.	Ensure that power supplies with matching wattage are installed. See the Technical Specifications outlined in your system's <i>Getting Started Guide</i> .
E1629	Power required > PSU wattage. Check PSU and config.	The system configuration requires more power than the power supplies can provide, even with throttling.	Turn off power to the system, reduce the hardware configuration or install higher-wattage power supplies, and then restart the system.

Code	Text	Causes	Corrective Actions
E1631	System power draw exceeded threshold. Contact support.	The processors and memory throttling is not sufficient to keep system power consumption below the maximum safe level with current power supply configuration.	Remove AC power to the system for 10 seconds and restart the system. If the problem persists, see "Getting Help" on page 203.
E1632	PowerSafe event. Contact support.	The processors and memory have been throttled to keep system power consumption below the maximum safe level with current power supply configuration.	Remove AC power to the system for 10 seconds and restart the system. If the problem persists, see "Getting Help" on page 203.
E1710	I/O channel check error. Review & clear SEL.	The system BIOS reported an I/O channel check.	Check the SEL for more information and then clear the SEL. Remove AC power to the system for 10 seconds and restart the system. If the problem persists, see "Getting Help" on page 203.
E1711	PCI parity error on Bus ## Device ## Function ##.	The system BIOS reported a PCI parity error on a component that resides in PCI configuration space at bus ##, device ##, function ##.	Remove and reseat the PCIe expansion cards. If the problem persists, see "Troubleshooting Expansion Cards" on page 189.
	PCI parity error on Slot #. Review & clear SEL.	The system BIOS reported a PCI parity error on a component that resides in the specified slot.	Remove and reseat the PCIe expansion cards. If the problem persists, see "Troubleshooting Expansion Cards" on page 189.

Code	Text	Causes	Corrective Actions
E1712	PCI system error on Bus ## Device ## Function ##.	The system BIOS reported a PCI system error on a component that resides in PCI configuration space at bus ##, device ##, function ##.	Remove and reseat the PCIe expansion cards. If the problem persists, see "Troubleshooting Expansion Cards" on page 189.
	PCI system error on Slot #. Review & clear SEL.	The system BIOS reported a PCI system error on a component that resides in the specified slot.	Reinstall the expansion-card riser. See "Expansion Cards and Expansion-Card Riser" on page 123. If the problem persists, the riser card or system board is faulty. See "Getting Help" on page 203.
E1714	Unknown error. Review & clear SEL.	The system BIOS determined there has been an error in the system, but is unable to determine its origin.	Check the SEL for more information and then clear the SEL. Remove AC power to the system for 10 seconds and restart the system. If the problem persists, see "Getting Help" on page 203.
E1715	Fatal I/O Error. Review & clear SEL.	The system BIOS determined there has been a fatal error in the system.	Check the SEL for more information, and then clear the SEL. Remove AC power to the system for 10 seconds, and restart the system. If the problem persists, see "Getting Help" on page 203.

Code	Text	Causes	Corrective Actions
E1716	Chipset IERR Bus ## Dev ## Function ##. Review & clear SEL.	The system BIOS reported a chipset internal error that resides in bus ##, device ##, function ##.	Check the SEL for more information, and then clear the SEL. Remove AC power to the system for 10 seconds, and restart the system. If the problem persists, see "Getting Help" on page 203.
E1717	CPU # internal error. Review & clear SEL.	The system BIOS determined that the specified processor has had an internal error.	Check the SEL for more information, and then clear the SEL. Remove AC power to the system for 10 seconds, and restart the system. If the problem persists, see "Getting Help" on page 203.
E171F	PCIe fatal error on Bus ## Device ## Function ##.	The system BIOS has reported a PCIe fatal error on a component that resides in PCI configuration space at bus ##, device ##, function ##.	Remove and reseat the PCIe expansion cards. If the problem persists, see "Troubleshooting Expansion Cards" on page 189.
	PCIe fatal error on Slot #. Review & clear SEL.	The system BIOS has reported a PCIe fatal error on a component that resides in the specified slot.	Reinstall the expansion-card riser. See "Expansion Cards and Expansion-Card Riser" on page 123. If the problem persists, the riser card or system board is faulty. See "Getting Help" on page 203.
E1810	Hard drive ## fault. Review & clear SEL.	The specified hard drive experienced a fault.	See "Troubleshooting a Hard Drive" on page 186.

Code	Text	Causes	Corrective Actions
E1812	Hard drive ## removed. Check drive.	The specified hard drive has been removed from the system.	Information only.
E1813	Internal Dual SD Module Card # failed. Check SD card.	The internal dual SD module card has failed.	Reseat the internal dual SD module card. If the problem persists, see "Getting Help" on page 203.
E1814	Internal SD Module Card # write-protected. Check SD card.	The internal dual SD module card is write-protected and cannot be used.	Change the write-protect switch setting on SD card.
E1815	Internal Dual SD Module redundancy lost. Check SD cards.	The internal dual SD module bootable media is no longer redundant.	Initiate a rebuild on the next POST execution. Reseat the internal dual SD module card. See "Removing an Internal SD Card" on page 141 and "Installing an Internal SD Card" on page 141. If the problem persists, see "Getting Help" on page 203.
E1A14	SAS cable A failure. Check connection.	SAS cable A is missing or bad.	Reseat the cable. If the problem persists, replace cable. If the problem persists, see "Getting Help" on page 203.

Code	Text	Causes	Corrective Actions
E1A15	SAS cable B failure. Check connection.	SAS cable B is missing or bad.	Reseat the cable. If the problem persists, replace cable. If the problem persists, see "Getting Help" on page 203
E1A1D	Control panel USB cable not detected. Check cable.	USB cable to the control panel is missing or bad.	Reseat the cable. If the problem persists, replace cable. If the problem persists, see "Getting Help" on page 203.
E2010	Memory not detected. Inspect DIMMs.	No memory was detected in the system.	Install memory or reseat the memory risers and memory modules. See "Installing a Memory Riser" on page 101, "Installing Memory Modules" on page 102 or "Troubleshooting System Memory" on page 181.
E2011	Memory configuration failure. Check DIMMs.	Memory detected, but is not configurable. Error detected during memory configuration.	See "Troubleshooting System Memory" on page 181.
E2012	Memory configured but unusable. Check DIMMs.	Memory configured, but is unusable.	See "Troubleshooting System Memory" on page 181.
E2013	BIOS unable to shadow memory. Check DIMMs.	The system BIOS failed to copy its flash image into memory.	See "Troubleshooting System Memory" on page 181.

Code	Text	Causes	Corrective Actions
E2014	CMOS RAM failure. Power cycle AC.	CMOS failure. CMOS RAM not functioning properly.	Remove AC power to the system for 10 seconds and restart the system. If the problem persists, see "Getting Help" on page 203.
E2015	DMA Controller failure. Power cycle AC.	DMA controller failure.	Remove AC power to the system for 10 seconds and restart the system. If the problem persists, see "Getting Help" on page 203.
E2016	Interrupt Controller failure. Power cycle AC.	Interrupt controller failure.	Remove AC power to the system for 10 seconds and restart the system. If the problem persists, see "Getting Help" on page 203.
E2017	Timer refresh failure. Power cycle AC.	Timer refresh failure.	Remove AC power to the system for 10 seconds and restart the system. If the problem persists, see "Getting Help" on page 203.
E2018	Programmable Timer error. Power cycle AC.	Programmable interval timer error.	Remove AC power to the system for 10 seconds and restart the system. If the problem persists, see "Getting Help" on page 203.
E2019	Parity error. Power cycle AC.	Parity error.	Remove AC power to the system for 10 seconds and restart the system. If the problem persists, see "Getting Help" on page 203.

Code	Text	Causes	Corrective Actions
E201A	SuperIO failure. Power cycle AC.	SIO failure.	Remove AC power to the system for 10 seconds and restart the system. If the problem persists, see "Getting Help" on page 203.
E201B	Keyboard Controller error. Power cycle AC.	Keyboard controller failure.	Remove AC power to the system for 10 seconds and restart the system. If the problem persists, see "Getting Help" on page 203.
E201C	SMI initialization failure. Power cycle AC.	System management interrupt (SMI) initialization failure.	Remove AC power to the system for 10 seconds and restart the system. If the problem persists, see "Getting Help" on page 203.
E201D	Shutdown test failure. Power cycle AC.	BIOS shutdown test failure.	Remove AC power to the system for 10 seconds and restart the system. If the problem persists, see "Getting Help" on page 203.
E201E	POST memory test failure. Check DIMMs.	BIOS POST memory test failure.	See "Troubleshooting System Memory" on page 181. If the problem persists, see "Getting Help" on page 203.
E2020	CPU configuration failure. Check screen message.	Processor configuration failure.	Check screen for specific error messages. See "Troubleshooting the Processors" on page 190.

Code	Text	Causes	Corrective Actions
E2021	Incorrect memory configuration. Review User Guide.	Incorrect memory configuration.	Check screen for specific error messages. See "Troubleshooting System Memory" on page 181.
E2022	General failure during POST. Check screen message.	General failure after video.	Check screen for specific error messages.
E2025	QPI initialization error. Contact support.	QuickPath Interconnect (QPI) failure.	See "Getting Help" on page 203.
E2026	Memory initialization error. Contact support.	Invalid memory configuration.	Ensure that the memory modules are installed in a valid configuration. See "General Memory Module Installation Guidelines" on page 92. See "Getting Help" on page 203.
E2110	Multibit Error on DIMM ##. Reseat DIMM.	The memory module in slot "##" has had a multi-bit error (MBE).	See "Troubleshooting System Memory" on page 181.
E2111	SBE log disabled on DIMM ##. Reseat DIMM.	The system BIOS has disabled memory single-bit error (SBE) logging and will not log any more SBEs until the system is rebooted. "##" represents the memory module implicated by the BIOS.	Remove AC power to the system for 10 seconds and restart the system. If the problem persists, see "Troubleshooting System Memory" on page 181.

Code	Text	Causes	Corrective Actions
E2112	Memory spared on Card x DIMM ##. Power cycle AC.	The system BIOS spared the memory because it has determined the memory has too many errors.	Remove AC power to the system for 10 seconds and restart the system. If the problem persists, see "Troubleshooting System Memory" on page 181.
E2113	Mem mirror OFF on DIMM ## & ##. Power cycle AC.	The system BIOS disabled memory mirroring because it has determined one half of the mirror has had too many errors. "## & ##" represents the memory module pair implicated by the BIOS.	Remove AC power to the system for 10 seconds and restart the system. If the problem persists, see "Troubleshooting System Memory" on page 181.
I1910	Intrusion detected. Check chassis cover.	System cover has been removed.	Information only.
I1911	LCD Log Full. Check SEL to review all Errors.	LCD overflow message. A maximum of ten error messages can display sequentially on the LCD. The eleventh message instructs the user to check the SEL for details on the events.	Check the SEL for details on the events. Remove AC power to the system for 10 seconds or clear the SEL.
I1912	SEL full. Review & clear log.	The SEL is full of events and is unable to log any more.	Check the SEL for more information and then clear the SEL.
W1100	CPU VCORE Regulator temp exceeding range. Check fans.	The regulator temperature has reached a point outside of the allowed range.	See "Troubleshooting System Cooling Problems" on page 180. If the problem persists, see "Getting Help" on page 203.

Code	Text	Causes	Corrective Actions
W1101	CPU VCACHE Regulator temp exceeding range. Check fans.	The regulator temperature has reached a point outside of the allowed range.	See "Troubleshooting System Cooling Problems" on page 180. If the problem persists, see "Getting Help" on page 203.
W1102	Mem Voltage Regulator temp exceeding range. Check fans	The regulator temperature has reached a point outside of the allowed range.	See "Troubleshooting System Cooling Problems" on page 180. If the problem persists, see "Getting Help" on page 203.
W1228	RAID Controller battery capacity < 24hr.	Warns predictively that the RAID battery has less than 24 hours of charge left.	Allow RAID battery to charge to greater than 24 hours of sustained charge. If problem persists, replace the RAID battery. See "Installing the RAID Battery" on page 146.
W1627	Power required > PSU wattage. Check PSU and config.	The system configuration requires more power than what the power supply can provide.	Turn off power to the system, reduce the hardware configuration or install higher-wattage power supplies, and then restart the system.
W1628	Performance degraded. Check PSU and system configuration.	The system configuration requires more power than what the power supply can provide, but it can boot if throttled.	Turn off power to the system, reduce the hardware configuration or install higher-wattage power supplies, and then restart the system.

Code	Text	Causes	Corrective Actions
W1630	Power supply redundancy degraded. Check PSU cables.	The power supply subsystem is no longer fully redundant, but at least one more supply can fail before the system is at risk of shutting down.	Reseat the power supplies. See "Troubleshooting Power Supplies" on page 179. If the problem persists, see "Getting Help" on page 203.

NOTE: For the full name of an abbreviation or acronym used in this table, see the *Glossary* at dell.com/support/manuals.

System Messages

System messages appear on the screen to notify you of a possible problem with the system.



NOTE: If you receive a system message not listed in the table, check the documentation for the application that is running when the message appears or the operating system's documentation for an explanation of the message and recommended action.

Table 1-2. System Messages

Message	Causes	Corrective Actions
Alert! iDRAC6 not responding. Rebooting.	The iDRAC6 is not responding to BIOS communication either because it is not functioning properly or has not completed initialization. The system will reboot.	Wait for the system to reboot.

Message	Causes	Corrective Actions
Alert! iDRAC6 not responding. Power required may exceed PSU wattage. Alert! Continuing system boot accepts the risk that system may power down without warning.	The iDRAC6 is hung. The iDRAC6 was remotely reset while system was booting After AC recovery, the iDRAC6 takes longer than normal to boot.	Remove AC power to the system for 10 seconds and restart the system.
Alert! Node Interleaving disabled! Memory configuration does not support Node Interleaving.	The memory configuration does not support node interleaving, or the configuration has changed (for example, a memory module has failed) so that node interleaving cannot be supported. The system will run but without node interleaving.	Ensure that the memory modules are installed in a configuration that supports node interleaving. Check other system messages for additional information for possible causes. For memory configuration information, see "General Memory Module Installation Guidelines" on page 92. If the problem persists, see "Troubleshooting System Memory" on page 181.

Message	Causes	Corrective Actions
Alert! Power required exceeds PSU wattage. Check PSU and system configuration. Alert! Continuing system boot accepts the risk that system may power down without warning.	The system configuration of processor(s), memory modules, and expansion cards may not be supported by the power supplies.	If any system components were just upgraded, return the system to the previous configuration. If the system boots without this warning, then the replaced component(s) are not supported with this power supply. If Energy Smart power supplies are installed, replace them with the High Output power supplies to use the components. See "Power Supplies" on page 153.
Alert! Redundant memory disabled! Memory configuration does not support redundant memory.	Memory Mirroring was enabled in the system setup program, but the current configuration does not support redundant memory. A memory module may be faulty.	Check the memory modules for failure. See "Troubleshooting System Memory" on page 181. Reset the memory setting, if appropriate. See "Using the System Setup Program and UEFI Boot Manager" on page 63.
Alert! System fatal error during previous boot.	An error caused the system to reboot.	Check other system messages for additional information for possible causes.
BIOS MANUFACTURING MODE detected. MANUFACTURING MODE will be cleared before the next boot. System reboot required for normal operation.	System is in manufacturing mode.	Reboot to take the system out of manufacturing mode.

Message	Causes	Corrective Actions
BIOS Update Attempt Failed!	Remote BIOS update attempt failed.	Retry the BIOS update. If problem persists, see "Getting Help" on page 203.
Caution! NVRAM_CLR jumper is installed on system board.	NVRAM_CLR jumper is installed in the clear setting. CMOS has been cleared.	Move the NVRAM_CLR jumper to the default position (pins 3 and 5). See Figure 6-1 for jumper location. Restart the system and re-enter the BIOS settings. See "Using the System Setup Program and UEFI Boot Manager" on page 63.
CPU set to minimum frequency.	The processor speed may be intentionally set lower for power conservation.	If not an intentional setting, check any other system messages for possible causes.
CPUs with different cache sizes detected. CPUs with different core sizes detected! System halted	Mismatched processors have been installed in the system.	Ensure that all processors have the same cache size, number of cores and logical processors, and power rating. Ensure that the processors are properly installed. See "Processors" on page 147.
CPUs with different logical processors detected! System halted.		
CPUs with different power rating detected! System halted.		

Message	Causes	Corrective Actions
Current boot mode is set to UEFI. Please ensure compatible bootable media is available. Use the system setup program to change the boot mode as needed.	The system failed to boot because UEFI boot mode is enabled in BIOS and the boot operating system is non-UEFI.	Ensure that the boot mode is set correctly and that the proper bootable media is available. See "Using the System Setup Program and UEFI Boot Manager" on page 63.
Embedded NICx and NICy: OS NIC=<ENABLED /DISABLED>, Management Shared NIC=<ENABLED /DISABLED>	The operating system NIC interface is set in BIOS. The Management Shared NIC interface is set in management tools.	Check the system management software or the System Setup program for NIC settings. If a problem is indicated, see "Troubleshooting a NIC" on page 175.
Error 8602 - Auxiliary Device Failure. Verify that mouse and keyboard are securely attached to correct connectors.	Mouse or keyboard cable is loose or improperly connected. Defective mouse or keyboard.	Reseat the mouse or keyboard cable. Ensure that the mouse or keyboard is operational. See "Troubleshooting a USB Device" on page 174.
Gate A20 failure	Faulty keyboard controller; faulty system board.	See "Getting Help" on page 203.
General failure	The operating system is unable to carry out the command.	This message is usually followed by specific information. Note the information, and take the appropriate action to resolve the problem.

Message	Causes	Corrective Actions
Invalid configuration information - please run SETUP program.	An invalid system configuration caused a system halt.	Run the System Setup program and review the current settings. See "Using the System Setup Program and UEFI Boot Manager" on page 63.
Invalid PCIe card found in the Internal_Storage slot!	The system halted because an invalid PCIe expansion card is installed in the dedicated storage controller slot.	Remove the PCIe expansion card and install the integrated storage controller in the dedicated slot. See "Integrated Storage Controller Card" on page 142.
Keyboard controller failure	Faulty keyboard controller; faulty system board	See "Getting Help" on page 203.
Keyboard data line failure Keyboard stuck key failure	Keyboard cable connector is improperly connected or the keyboard is defective.	Reseat the keyboard cable. If the problem persists, see "Troubleshooting a USB Device" on page 174.
Keyboard fuse has failed	Overcurrent detected at the keyboard connector.	See "Getting Help" on page 203.
Local keyboard may not work because all user accessible USB ports are disabled. If operating locally, power cycle the system and enter system setup program to change settings.	The USB ports are disabled in the system BIOS.	Power down and restart the system from the power button, and then enter the System Setup program to enable the USB port(s). See "Entering the System Setup Program" on page 64.

Message	Causes	Corrective Actions
Memory Riser <x> disabled - SMI channel training failure.	The memory riser connector is not properly seated.	Reseat the memory riser(s). See "Removing a Memory Riser" on page 100 and "Installing a Memory Riser" on page 101.
Memory Riser <x> disabled - Memory Buffer communication error.	The memory riser connector or the processor socket may be exposed to dust. The processor has bent pins.	Ensure that the memory riser connectors and processor sockets are clean. Verify that there are no bent pins on the processor. If the processor has bent pins, see "Getting Help" on page 203.
Memory Riser <x> disabled - MemBIST error.	The memory modules are not properly seated.	Replace or reseat the memory module(s). See "Removing Memory Modules" on page 105 and "Installing Memory Modules" on page 102.
Memory Riser <x> disabled - MemBIST timeout.	The memory module connector may be exposed to dust.	Ensure that the memory module connectors are clean and supported memory modules are installed in a valid configuration. See "General Memory Module Installation Guidelines" on page 92.
Memory Riser <x> disabled - Rank not found.	Unsupported memory module.	
Memory riser <x> disabled - DIMM communication error		
Memory Riser <x> disabled - DDR training failure		
Memory Riser <x> disabled - Simple memory test failure.		

Message	Causes	Corrective Actions
Memory Riser <x> disabled - No Memory detected.	<p>The memory modules are not properly seated.</p> <p>The memory module connector may be exposed to dust.</p> <p>Unsupported memory module.</p>	<p>Replace or reseat the memory module(s). See "Removing Memory Modules" on page 105 and "Installing Memory Modules" on page 102.</p> <p>Verify that the memory modules are identical and not in a locked step pair.</p>
Memory Riser <x> disabled - Invalid DIMM.	Unsupported memory modules in the first locked step pair.	<p>See "General Memory Module Installation Guidelines" on page 92.</p> <p>Replace the memory modules. See "Removing Memory Modules" on page 105 and "Installing Memory Modules" on page 102.</p>
Memory Riser <x> disabled - No DIMM detected.	An empty memory riser is installed.	Install memory modules in the riser. See "General Memory Module Installation Guidelines" on page 92.
<p>DIMM unsupported:</p> <p>Memory Riser <x> DIMM<y></p> <p>Memory Riser<x> Lockstep pair</p> <p>DIMM <y & z> disabled</p> <p>Please replace the DIMM or remove the lockstep pair</p>	Unsupported memory modules on slots 3 to 8.	Ensure that the memory modules are installed in a valid configuration. See "General Memory Module Installation Guidelines" on page 92.

Message	Causes	Corrective Actions
DIMM mismatch: Memory Riser <x> Lockstep Pair DIMM <y & z> disabled. Please replace the lockstep pair with matching DIMM(s).	Locked step pairs do not match.	Ensure that the memory modules match for a locked step pair. See "General Memory Module Installation Guidelines" on page 92.
MemBIST timeout: Memory riser<x> Locstep Pair DIMM <x & y> disabled. Please replace the DIMM(s) or remove the lockstep pair.	The memory modules are not properly seated. The memory module connector may be exposed to dust. Faulty memory module.	Replace or reseal the memory module(s). See "Removing Memory Modules" on page 105 and "Installing Memory Modules" on page 102. Ensure that the memory module connectors are clean.
MemBIST error: Memory riser(s) <x> Locstep Pair DIMM <x & y> disabled. Please replace the DIMM(s) or remove the lockstep pair.		
DDR training Error: Memory riser <x> DIMM <y> Memory riser <x> lockstep pair <y & z> disabled. Please replace the DIMM(s) or remove the lockstep pair.		

Message	Causes	Corrective Actions
<p>DIMM population violation: Memory riser <x> DIMM <y> Memory riser <x> lockstep pair DIMM <x & y> disabled.</p> <p>Please populate DIMM(s) with largest number of ranks in the lowest slot.</p>	<p>While mixing different rank memory modules, the lower rank memory modules are installed on slots 1 and 2 or on slots 5 and 6.</p>	<p>Ensure that the memory modules are installed in a valid configuration. See "General Memory Module Installation Guidelines" on page 92.</p>
<p>DDR Channel Disabled.</p> <p>Memory riser <x> lockstep pair DIMM <y & z> disabled.</p> <p>Memory riser <x> lockstep pair DIMM <y & z> disabled.</p> <p>Please ensure each lockstep pair is installed correctly.</p>		

Message	Causes	Corrective Actions
DellMemBIST timeout: Memory riser <x> DIMM <y> Memory riser <x> lockstep pair DIMM <x & y> disabled. Please replace the DIMM(s) or remove the lockstep pair.	The memory modules are not properly seated. The memory module connector may be exposed to dust. Faulty memory module.	Replace or reset the memory module(s). See "Removing Memory Modules" on page 105 and "Installing Memory Modules" on page 102. Ensure that the memory module connectors are clean.
DellMemBIST error: Memory riser <x> DIMM <y> Memory riser <x> lockstep pair DIMM <x & y> disabled. Please replace the DIMM or remove the lockstep pair.		
Manufacturing mode detected.	System is in manufacturing mode.	Reboot to take the system out of manufacturing mode.
Memory address line failure at <i>address</i> , read <i>value</i> expecting <i>value</i> .	Faulty or improperly installed memory modules.	See "Troubleshooting System Memory" on page 181.
Memory double word logic failure at <i>address</i> , read <i>value</i> expecting <i>value</i> .	Faulty or improperly installed memory modules.	See "Troubleshooting System Memory" on page 181.

Message	Causes	Corrective Actions
Memory Initialization Warning: Memory size may be reduced.	Invalid memory configuration. The system will run but with less memory than is physically available.	Ensure that the memory modules are installed in a valid configuration. See "General Memory Module Installation Guidelines" on page 92.
Memory odd/even logic failure at <i>address</i> , read <i>value</i> expecting <i>value</i> .	Faulty or improperly installed memory modules.	See "Troubleshooting System Memory" on page 181.
Memory write/read failure at <i>address</i> , read <i>value</i> expecting <i>value</i> .	Faulty or improperly installed memory modules.	See "Troubleshooting System Memory" on page 181.
Memory set to minimum frequency.	<p>The memory frequency may be intentionally set lower for power conservation.</p> <p>The current memory configuration may support only the minimum frequency.</p>	<p>If not an intentional setting, check any other system messages for possible causes.</p> <p>Ensure that your memory configuration supports the higher frequency. See "General Memory Module Installation Guidelines" on page 92.</p>
Memory tests terminated by keystroke.	POST memory test was terminated by pressing a key.	Information only.

Message	Causes	Corrective Actions
No boot device available.	Faulty or missing optical drive subsystem, hard drive, or hard-drive subsystem, or no bootable USB key installed.	Use a bootable USB key, CD, or hard drive. If the problem persists, see "Troubleshooting an Internal USB Key" on page 183, "Troubleshooting a USB Device" on page 174, "Troubleshooting an Optical Drive" on page 185, and "Troubleshooting a Hard Drive" on page 186. See "Using the System Setup Program and UEFI Boot Manager" on page 63 for information on setting the order of boot devices.
No boot sector on hard drive.	Incorrect configuration settings in System Setup program, or no operating system on hard drive.	Check the hard-drive configuration settings in the System Setup program. See "Using the System Setup Program and UEFI Boot Manager" on page 63. If necessary, install the operating system on your hard drive. See your operating system documentation.
No timer tick interrupt.	Faulty system board.	See "Getting Help" on page 203.
PCI BIOS failed to install.	PCIe device BIOS (Option ROM) checksum failure detected during shadowing. Cables to expansion card(s) loose; faulty or improperly installed expansion card(s).	Reseat the expansion card(s). Ensure that all appropriate cables are securely connected to the expansion card(s). If the problem persists, see "Troubleshooting Expansion Cards" on page 189.

Message	Causes	Corrective Actions
PCIe Training Error: Expected Link Width is x, Actual Link Width is y.	Faulty or improperly installed PCIe card in the specified slot.	Reseat the PCIe card in the specified slot number. See "Troubleshooting Expansion Cards" on page 189. If the problem persists, see "Getting Help" on page 203.
Plug & Play Configuration Error.	Error encountered in initializing PCIe device; faulty system board.	Install the NVRAM_CLR jumper in the clear position (pins 1 and 3) and reboot the system. See Figure 6-1 for jumper location. If the problem persists, see "Troubleshooting Expansion Cards" on page 189.
Read fault Requested sector not found.	The operating system cannot read from the hard drive, optical drive, or USB device, the system could not find a particular sector on the disk, or the requested sector is defective.	Replace the optical medium, USB medium or device. Ensure that the SAS backplane, USB, or SATA cables are properly connected. See "Troubleshooting a USB Device" on page 174, "Troubleshooting an Optical Drive" on page 185, or "Troubleshooting a Hard Drive" on page 186 for the appropriate drive(s) installed in your system.
SATA Portx device not found.	There is no device connected to the specified SATA port.	Information only.

Message	Causes	Corrective Actions
SATA port x device auto-sensing error SATA port x device configuration error. SATA port x device error	The drive connected to the specified SATA port is faulty.	Replace the faulty drive.
Sector not found Seek error Seek operation failed	Faulty hard drive, USB device, or USB medium.	Replace the USB medium or device. Ensure that the USB or SAS backplane cables are properly connected. See "Troubleshooting a USB Device" on page 174 or "Troubleshooting a Hard Drive" on page 186 for the appropriate drive(s) installed in your system.
Shutdown failure	General system error.	See "Getting Help" on page 203.
The amount of system memory has changed.	Memory has been added or removed or a memory module may be faulty.	If memory has been added or removed, this message is informative and can be ignored. If memory has not been added or removed, check the SEL to determine if single-bit or multi-bit errors were detected and replace the faulty memory module. See "Troubleshooting System Memory" on page 181.
Time-of-day clock stopped.	Faulty battery or faulty chip.	See "Troubleshooting the System Battery" on page 178.

Message	Causes	Corrective Actions
Time-of-day not set - please run SETUP program.	Incorrect Time or Date settings; faulty system battery.	Check the Time and Date settings. See "Using the System Setup Program and UEFI Boot Manager" on page 63. If the problem persists, replace the system battery. See "System Battery" on page 156.
Timer chip counter 2 failed.	Faulty system board.	See "Getting Help" on page 203.
TPM or TCM configuration operation honored. System will now reset.	A Trusted Platform Module (TPM) or China Trusted Computing Model (TCM) configuration command has been entered. The system will reboot and execute the command.	Information only.
TPM or TCM configuration operation is pending. Press (I) to Ignore OR (M) to Modify to allow this change and reset the system. WARNING: Modifying could prevent security.	This message displays during system restart after a TPM or TCM configuration command has been entered. User interaction is required to proceed.	Enter I or M to proceed.
TPM or TCM failure.	A TPM or TCM function has failed.	See "Getting Help" on page 203.

Message	Causes	Corrective Actions
Unable to launch System Services image. System halted!	System halted after F10 keystroke because System Services image is either corrupted in the system firmware or has been lost due to system board replacement. The iDRAC6 Enterprise card flash memory may be corrupted.	Restart the system and update the Lifecycle Controller repository to the latest software to restore full functionality. See the Lifecycle Controller user documentation for more information. Restore the flash memory using the latest version on support.dell.com. See the iDRAC6 user's guide for instructions on performing a field replacement of the flash memory.
Unexpected interrupt in protected mode.	Improperly seated memory modules or faulty keyboard/mouse controller chip.	Reseat the memory modules. See "Troubleshooting System Memory" on page 181. If the problem persists, see "Getting Help" on page 203.
Unsupported CPU combination. Unsupported CPU stepping detected.	Processor(s) is not supported by the system.	Install a supported processor or processor combination. See "Processors" on page 147.
Warning: A fatal error has caused system reset! Please check the system event log!	A fatal system error occurred and caused the system to reboot.	Check the SEL for information that was logged during the error. See the applicable troubleshooting section in "Troubleshooting Your System" on page 173 for any faulty components specified in the SEL.

Message	Causes	Corrective Actions
Warning: Control Panel is not installed.	The control panel is not installed or has a faulty cable connection.	Install the control panel, or check the cable connections between the display module, the control panel board, and the system board. See "Control Panel Assembly" on page 162.
Warning! No micro code update loaded for processor <i>n</i> .	Micro code update failed.	Update the BIOS firmware. See "Getting Help" on page 203.
Warning! Power required exceeds PSU wattage. Check PSU and system configuration. Warning! Performance degraded. CPU and memory set to minimum frequencies to meet PSU wattage. System will reboot.	The system configuration of processor(s), memory modules, and expansion cards may not be supported by the power supplies.	If any system components were just upgraded, return the system to the previous configuration. If the system boots without this warning, then the replaced component(s) are not supported with this power supply. If Energy Smart power supplies are installed, replace them with High Output power supplies to use the components. See "Power Supplies" on page 153.
Warning! PSU mismatch. PSU redundancy lost. Check PSU.	A High Output power supply and an Energy Smart power supply are installed in the system at the same time.	Install two High Output or two Energy Smart power supplies in the system. You can also run the system on one power supply until you can obtain two power supplies of the same type. See "Troubleshooting Power Supplies" on page 179.

Message	Causes	Corrective Actions
The memory configuration is not optimal. The recommended memory configuration is: <message>	Invalid memory configuration. The system will run but with reduced functionality.	Ensure that the memory modules are installed in a valid configuration. See "General Memory Module Installation Guidelines" on page 92. If the problem persists, see "Troubleshooting System Memory" on page 181.
Write fault Write fault on selected drive.	Faulty USB device, USB medium, optical drive assembly, hard drive, or hard-drive subsystem.	Replace the USB medium or device. Ensure that the USB, SAS backplane, or SATA cables are properly connected. See "Troubleshooting a USB Device" on page 174, "Troubleshooting an Internal USB Key" on page 183, and "Troubleshooting a Hard Drive" on page 186.
Warning: QPI links operating in Slow Speed Mode. Warning: QPI link between <Agent X> Port <Y> and <Agent X1> <Port Y1> failed. Warning: QPI link between <Agent X> Port <Y> and <Agent X1> <Port Y1> degraded to half-width.	The processor has bent pins. The processor is not properly seated on the processor socket.	Verify that there are no bent pins on the processor. If the processor has bent pins, see "Getting Help" on page 203. Reseat the processors. See "Removing a Processor" on page 147 and "Installing a Processor" on page 151. If the problem persists, see "Getting Help" on page 203.

NOTE: For the full name of an abbreviation or acronym used in this table, see the *Glossary* at dell.com/support/manuals.

Warning Messages

A warning message alerts you to a possible problem and prompts you to respond before the system continues a task. For example, before you format a diskette, a message will warn you that you may lose all data on the diskette. Warning messages usually interrupt the task and require you to respond by typing *y* (yes) or *n* (no).

 **NOTE:** Warning messages are generated by either the application or the operating system. For more information, see the documentation that accompanied the operating system or application.

Diagnostics Messages

The system diagnostic utilities may issue messages if you run diagnostic tests on your system. See "Running the System Diagnostics" on page 193 for more information about system diagnostics.

Alert Messages

Systems management software generates alert messages for your system. Alert messages include information, status, warning, and failure messages for drive, temperature, fan, and power conditions. For more information, see the systems management software documentation.

Other Information You May Need

 **WARNING:** See the safety and regulatory information that shipped with your system. Warranty information may be included within this document or as a separate document.

- The rack documentation included with your rack solution describes how to install your system into a rack.
- The *Getting Started Guide* provides an overview of system features, setting up your system, and technical specifications.

- Dell systems management application documentation at [dell.com/support/manuals](https://support.dell.com/manuals) provides information about installing and using the systems management software.
- Any media that ships with your system that provides documentation and tools for configuring and managing your system, including those pertaining to the operating system, system management software, system updates, and system components that you purchased with your system.



NOTE: Always check for updates on support.dell.com/manuals and read the updates first because they often supersede information in other documents.

Using the System Setup Program and UEFI Boot Manager

The System Setup program is the BIOS program that enables you to manage your system hardware and specify BIOS-level options. From the System Setup program, you can:

- Change the NVRAM settings after you add or remove hardware
- View the system hardware configuration
- Enable or disable integrated devices
- Set performance and power management thresholds
- Manage system security

Choosing the System Boot Mode

The System Setup program also enables you to specify the boot mode for installing your operating system:

- BIOS boot mode (the default) is the standard BIOS-level boot interface.
- UEFI boot mode is an enhanced 64-bit boot interface based on Unified Extensible Firmware Interface (UEFI) specifications that overlays the system BIOS. See "Entering the UEFI Boot Manager" on page 76 for more information on this interface.

You must select the boot mode in the **Boot Mode** field of the "Boot Settings Screen" on page 69 screen of the System Setup program. Once you specify the boot mode, the system boots in the specified boot mode and you proceed then to install your operating system from that mode. Thereafter, you must boot the system to the same boot mode (BIOS or UEFI) to access the installed operating system. Trying to boot the operating system from the other boot mode will cause the system to halt immediately at startup.



NOTE: Operating systems must be UEFI-compatible (for example, Microsoft® Windows Server® 2008 x64 version) to be installed from the UEFI boot mode. DOS and 32-bit operating systems do not support UEFI and can only be installed from the BIOS boot mode.

Entering the System Setup Program

- 1 Turn on or restart your system.
- 2 Press <F2> immediately after you see the following message:

<F2> = System Setup

If your operating system begins to load before you press <F2>, allow the system to finish booting, and then restart your system and try again.

Responding to Error Messages

If an error message appears while the system is booting, make a note of the message. See "System Messages" on page 41 for an explanation of the message and suggestions for correcting errors.



NOTE: After installing a memory upgrade, it is normal for your system to display a message the first time you start your system.

Using the System Setup Program Navigation Keys

Keys	Action
Up arrow or <Shift> <Tab>	Moves to the previous field.
Down arrow or <Tab>	Moves to the next field.
Spacebar, <+>, <->, left and right arrows	Cycles through the settings in a field. In many fields, you can also type the appropriate value.
<Esc>	Exits the System Setup program and restarts the system if any changes were made.
<F1>	Displays the System Setup program's help file.





NOTE: For most of the options, any changes that you make are recorded but do not take effect until you restart the system.

System Setup Options

Main Screen

Dell Inc. <www.dell.com> - PowerEdge R910 BIOS Version xx.yy.zz [This is DOS Setup]			
Service Tag: xxxxxxxx		Asset Tag: xxxxxxxxxxxx	
System Time 00:00:00 System Date DAY/MO/DATE/YR Memory Settings <Enter> Processor Settings <Enter> SATA Settings <Enter> Boot Settings <Enter> Integrated Devices <Enter> PCI IRQ Assignment <Enter> Serial Communication <Enter> Embedded Server Management <Enter> Power Management <Enter>			
Up,Down Arrow to select	SPACE, +, - to change	ESC to exit	F1 = Help

 **NOTE:** The options for the System Setup program change based on the system configuration.

 **NOTE:** The System Setup program defaults are listed under their respective options in the following sections, where applicable.

Option	Description
System Time	Sets the time on the system's internal clock.
System Date	Sets the date on the system's internal calendar.
Memory Settings	Displays information related to installed memory. See "Memory Settings Screen" on page 67.
Processor Settings	Displays information related to processors (speed, cache size, and so on). See "Processor Settings Screen" on page 68.

Option	Description
SATA Settings	Displays a screen to enable or disable the integrated SATA controller and ports. See "SATA Settings Screen" on page 69.
Boot Settings	Displays a screen to specify the boot mode (BIOS or UEFI). For BIOS boot mode, you can also specify the boot devices. See "Boot Settings Screen" on page 69.
Integrated Devices	Displays a screen to enable or disable integrated device controllers and ports, and to specify related features and options. See "Integrated Devices Screen" on page 70.
PCI IRQ Assignment	Displays a screen to change the IRQ assigned to each of the integrated devices on the PCI bus, and any installed expansion card that requires an IRQ. See "PCI IRQ Assignments Screen" on page 71.
Serial Communication	Displays a screen to enable or disable the serial ports and specify related features and options. See "Serial Communication Screen" on page 72.
Embedded Server Management	Displays a screen to configure the front-panel LCD options and to set a user-defined LCD string. See "Embedded Server Management Screen" on page 73.
Power Management	Enables you to manage power usage of the processor(s), fans, and memory modules with preconfigured or customized settings. See "Power Management Screen" on page 73.
System Security	Displays a screen to configure the system password and setup password features. See "System Security Screen" on page 74, "Using the System Password" on page 79, and "Using the Setup Password" on page 81 for more information.
Keyboard NumLock (On default)	Determines whether your system starts up with the NumLock mode activated on 101- or 102-key keyboards (does not apply to 84-key keyboards).

Option	Description
Report Keyboard Errors (Report default)	Enables or disables reporting of keyboard errors during the POST. Select Report for host systems that have keyboards attached. Select Do Not Report to suppress all error messages relating to the keyboard or keyboard controller during POST. This setting does not affect the operation of the keyboard itself if a keyboard is attached to the system.
F1/F2 Prompt on Error (Enabled default)	<p>Enables the system to halt on errors during POST, which allows the user to observe events that may scroll by unnoticed during normal POST. The user can press < F1 > to continue or < F2 > to enter the System Setup program.</p> <p> CAUTION: When setting this option to Disabled, the system will not halt if an error occurs during POST. Any critical errors will be displayed and logged in the system event log.</p>

Memory Settings Screen

Option	Description
System Memory Size	Displays the amount of system memory.
System Memory Type	Displays the type of system memory.
System Memory Speed	Displays the system memory speed.
Video Memory	Displays the amount of video memory.
System Memory Testing (Enabled default)	Specifies whether system memory tests are run at system boot. Options are Enabled and Disabled .
Redundant Memory (Disabled default)	Specifies whether redundant memory is enabled on the system. Options are Mirror Mode , Spare Mode , and Disabled .
Node Interleaving (Disabled default)	If this field is Enabled , memory interleaving is supported if a symmetric memory configuration is installed. If Disabled , the system supports Non-Uniform Memory architecture (NUMA) (asymmetric) memory configurations.

Processor Settings Screen

Option	Description
64-bit	Specifies if the processor(s) support 64-bit extensions.
Core Speed	Displays the processor clock speed.
Bus Speed	Displays the processor bus speed.
Logical Processor (Enabled default)	On processors that support Simultaneous Multi-Threading (SMT) technology, each processor core supports up to two logical processors. If this field is set to Enabled , the BIOS reports both logical processors. If set to Disabled , only one logical processor is monitored by the BIOS.
Virtualization Technology (Disabled default)	Enabled permits virtualization software to use the virtualization technology incorporated in the processor. NOTE: Disable this feature if your system will not be running virtualization software.
Adjacent Cache Line Prefetch (Enabled default)	Enable or disables system optimization for sequential memory access.
Hardware Prefetcher (Enabled default)	Enables or disables the hardware prefetcher.
Execute Disable (Enabled default)	Enables or disables Execute Disable Memory Protection Technology .
Number of Cores per Processor (All default)	If set to All , the maximum number of cores in each processor is enabled.
Turbo Mode	If Turbo Boost Technology is supported by the processor(s), enables or disables Turbo Mode .
C1E (Enabled default)	When set to Enabled , the processor can switch to a minimum performance state when idle.
C States	When set to Enabled , the processor(s) can operate in all available power states.
Processor Family-Model-Stepping	Displays the family, model, and stepping of the selected processor.

SATA Settings Screen

Option	Description
Embedded SATA (Off default)	ATA Mode enables the integrated SATA controller. Off disables the controller.
Port A (Off default)	Auto enables BIOS support for the device attached to SATA port A. Off disables BIOS support for the device.

Boot Settings Screen

Option	Description
Boot Mode (BIOS default)	 CAUTION: Switching the boot mode could prevent the system from booting if the operating system was not installed in the same boot mode. If the system operating system supports Unified Extensible Firmware Interface, you can set this option to UEFI. Setting this field to BIOS allows compatibility with non-UEFI operating systems. NOTE: Setting this field to UEFI disables the Boot Sequence , Hard-Disk Drive Sequence , and USB Flash Drive Emulation Type fields.
Boot Sequence	If Boot Mode is set to BIOS , this field tells the system where the operating system files needed for startup are located. If Boot Mode is set to UEFI , you can access the UEFI boot manager utility by rebooting the system and pressing < F11 > when prompted to do so.
Hard-Disk Drive Sequence	Determines the order in which the BIOS attempts to boot from hard drives in the system during system startup.

Option	Description
USB Flash Drive Emulation Type (Auto default)	<p>Determines the emulation type for a USB flash drive. Hard disk allows the USB flash drive to act as a hard drive. Floppy allows the USB flash drive to act as a removable diskette drive. Auto automatically chooses an emulation type.</p> <p>Auto automatically chooses the appropriate emulation type for the device, except for devices installed in the internal SD card slot. A device installed in the internal SD card slot will automatically emulate a hard drive. If you install a device in this slot that is configured as a removable diskette drive, you must manually set the emulation type to Floppy.</p>
Boot Sequence Retry (Disabled default)	If this field is enabled and the system has failed to boot, the system will reattempt to boot after 30 seconds.

Integrated Devices Screen

Option	Description
Integrated SAS Controller (Enabled default)	Enables or disables the integrated SAS controller.
User Accessible USB Ports (All Ports On default)	Enables or disables the user accessible USB ports. Options are All Ports On , Only Back Ports On , and All Ports Off .
Internal USB Port (On default)	Enables or disables the internal USB port.
Internal SD Card Port	Enables or disables the internal SD card port.
Redundancy (Disabled default)	Enables or disables the internal dual SD module mirror mode.
Embedded NIC1 and NIC2 (Enabled default)	Enables or disables the operating system interface of the embedded NICs. The NICs can also be accessed through the system's management controller.
Embedded NIC3 and NIC4 (Enabled default)	Enables or disables the operating system interface of the embedded NICs. The NICs can also be accessed through the system's management controller.

Option	Description
Embedded Gb NICx (NIC1 default: Enabled with PXE ; Other NICs: Enabled)	Enables or disables the integrated NIC. Options are Enabled , Enabled with PXE , Enabled with iSCSI Boot , and Disabled . PXE support allows the system to boot from the network.
MAC Address	Displays the MAC address for the integrated 10/100/1000 NIC.
Capability Detected	Displays the NIC features of the LOM NIC hardware key. NOTE: Some LOM features may require the installation of an additional driver.
OS Watchdog Timer (Disabled default)	Sets a timer to monitor the operating system for activity, and aids in recovery if the system stops responding. When Enabled , the operating system is allowed to initialize the timer. When Disabled , the timer is not initialized. NOTE: This feature is usable only with operating systems that support WDAT implementations of the Advanced Configuration and Power Interface (ACPI) 3.0b specification.
I/OAT DMA Engine (Disabled default)	Enables or disables the I/O Acceleration Technology feature.
Embedded Video Controller (Enabled default)	Enables or disables BIOS support for the integrated video controller. NOTE: This field can be disabled only if an add-in video card is present. If this field is disabled, remote access features such as virtual KVM are not available.
SR-IOV Global Enable (Enabled default)	Enables or disables the BIOS configuration of Single Root I/O Virtualization (SR-IOV) devices.

PCI IRQ Assignments Screen

Option	Description
< <i>PCIe device</i> >	Use the < + > and < - > keys to manually select an IRQ for a given device, or select Default to allow the BIOS to select an IRQ value at system startup.

Serial Communication Screen

Option	Description
Serial Communication (On without Console Redirection default)	<p>Selects whether the serial communication devices (Serial Device 1 and Serial Device 2) are enabled in BIOS. BIOS console redirection can also be enabled and the port address used can be specified.</p> <p>Options are On without Console Redirection, On with Console Redirection via COM1, On with Console Redirection via COM2, and Off.</p>
Serial Port Address (Serial Device 1= COM1, Serial Device2= COM2 default)	<p>Sets the serial port addresses for the two serial devices.</p> <p>NOTE: Only Serial Device 2 can be used for Serial Over LAN (SOL). To use console redirection by SOL, configure the same port address for console redirection and the serial device.</p>
External Serial Connector	<p>Specifies whether Serial Device 1, Serial Device 2, or Remote Access Device has access to the external serial connector.</p> <p>NOTE: Only Serial Device 2 can be used for Serial Over LAN (SOL). To use console redirection by SOL, configure the same port address for console redirection and the serial device.</p>
Failsafe Baud Rate (115200 default)	<p>Displays the failsafe baud rate used for console redirection. BIOS attempts to determine the baud rate automatically. This failsafe baud rate is used only if the attempt fails. This rate should not be adjusted.</p>
Remote Terminal Type (VT100/VT220 default)	<p>Sets the remote console terminal type, either VT100/VT220 or ANSI.</p>
Redirection After Boot (Enabled default)	<p>Enables or disables BIOS console redirection when the operating system is loaded.</p>

Embedded Server Management Screen

Option	Description
Front Panel LCD Options	<p>Options are User Defined String, Model Number, or None.</p> <p>If the LCD Home screen is set to an option other than these three choices, the option will be displayed as "Advanced" in the BIOS. In this event, the option cannot be changed in the BIOS unless it is changed back to User Defined String, Model Number, or None through another LCD configuration utility (such as the iDRAC Configuration Utility or the LCD panel menu).</p>
User-Defined LCD String	<p>You can enter a name or other identifier for the system, to be displayed on the LCD module screen.</p>

Power Management Screen

Option	Description
Power Management	<p>Options are OS Control, Active Power Controller, Custom, or Maximum Performance. For all but the Custom setting, the BIOS pre-configures the power settings on this screen as follows:</p> <ul style="list-style-type: none">• OS Control sets the CPU power to OS DBPM, the fan power to Minimum Power, and the memory power to Maximum Performance. In this setting, all processor performance information is passed from the system BIOS to the operating system for control. The operating system sets the processor performance based on processor utilization.• Active Power Controller sets the CPU power to System DBPM, the fan power to Minimum Power, and the memory power to Maximum Performance. The BIOS sets the processor performance based on processor utilization.• Maximum Performance sets all fields to Maximum Performance. <p>If you select Custom, you can configure each option independently.</p>

Option	Description
CPU Power and Performance Management	Options are OS DBPM , System DBPM , Maximum Performance , or Minimum Power .
Fan Power and Performance Management	Options are Maximum Performance or Minimum Power .
Memory Power and Performance Management	Options are Maximum Performance , a specified frequency, or Minimum Power .

System Security Screen

Option	Description
System Password	Displays the current status of the password security feature and allows a new system password assignment and verification. NOTE: See "Using the System Password" on page 79 for more information.
Setup Password	Restricts access to the System Setup program by using a setup password. NOTE: See "Using the System Password" on page 79 for more information.
Password Status (Unlocked default)	When Setup Password is assigned and this field is Locked , the system password cannot be changed or disabled at system start-up. See "Using the System Password" on page 79 for more information.

Option	Description
TPM Security (Off default)	<p>Sets the reporting of the Trusted Platform Module (TPM) in the system.</p> <p>If Off, the presence of the TPM is not reported to the operating system.</p> <p>If On with Pre-boot Measurements, the system reports the TPM to the operating system and stores the pre-boot measurements to the TPM during POST.</p> <p>If On without Pre-boot Measurements, the system reports the TPM to the operating system and bypasses pre-boot measurements.</p>
TPM Activation (No Change default)	<p>When set to Activate, the TPM is enabled to default settings. When set to Deactivate, the TPM is disabled. The No Change state initiates no action. The operational state of the TPM remains unchanged (all user settings for the TPM are preserved).</p> <p>NOTE: This field is read-only when TPM Security is set to Off.</p>
TPM Clear (No default)	<p> CAUTION: Clearing the TPM will lose all encryption keys in the TPM. This option prevents booting to the operating system and results in data loss if the encryption keys cannot be restored. Back up the TPM keys prior to enabling this option.</p> <p>When set to Yes, all TPM contents are cleared.</p> <p>NOTE: This field is read-only when TPM Security is set to Off.</p>
Power Button (Enabled default)	<p>If Enabled, the power button can turn the system's power off and on. On an ACPI-compliant operating system, the system performs an orderly shutdown before power is turned off.</p> <p>When Disabled, the button can only turn on system power.</p>

Option	Description
NMI Button (Disabled default)	 CAUTION: Use the NMI button only if directed to do so by qualified support personnel or by the operating system's documentation. Pressing this button halts the operating system and displays a diagnostic screen. Enables or disables the NMI feature.
AC Power Recovery (Last default)	Determines how the system reacts when power is restored. If set to Last , the system returns to the last power state. On turns on the system after power is restored. Off allows the system to remain off after power is restored.
AC Power Recovery Delay	Determines when the system restarts after power is restored. Options are Immediate , Random (a random value of 30 to 240 seconds), or a user-defined value of 30 to 240 seconds.

Exit Screen

Press < Esc > to exit the System Setup program; the **Exit** screen displays:

- Save Changes and Exit
- Discard Changes and Exit
- Return to Setup

Entering the UEFI Boot Manager

 **NOTE:** Operating systems must be 64-bit UEFI-compatible (for example, Microsoft® Windows Server® 2008 x64 version) to be installed from the UEFI boot mode. DOS and 32-bit operating systems can only be installed from the BIOS boot mode.

 **NOTE:** The Boot Mode must be set to **UEFI** in the System Setup program to access the UEFI Boot Manager.

The UEFI Boot Manager enables you to:

- Add, delete, and arrange boot options
 - Access the System Setup program and BIOS-level boot options without rebooting
- 1 Turn on or restart your system.

2 Press <F11> after you see the following message:

<F11> = UEFI Boot Manager

 **NOTE:** The system will not respond until the USB keyboard is active.

If your operating system begins to load before you press <F11>, allow the system to finish booting, and then restart your system and try again.

Using the UEFI Boot Manager Navigation Keys

Keys	Action
Up arrow	Moves to and highlights the previous field.
Down arrow	Moves to and highlights the next field.
Spacebar, <Enter>, <+>, <->	Cycles through the settings in a field.
<Esc>	Refreshes the UEFI Boot Manager screen, or returns to the UEFI Boot Manager screen from the other program screens.
<F1>	Displays the UEFI Boot Manager help file.

UEFI Boot Manager Screen

Option	Description
Continue	The system attempts to boot to devices starting with the first item in the boot order. If the boot attempt fails, the system will continue with the next item in the boot order until the boot is successful or no more boot options are found.
< Boot options>	Displays the list of available boot options (marked with asterisks). Select the boot option you wish to use and press Enter. NOTE: If you hot-add a boot device, press <Esc> to refresh the list of boot options.
UEFI Boot Settings	Enables you to add, delete, enable, or disable boot options; change boot order; or execute a one-time boot option.

Option	Description
System Utilities	Enables you to access the System Setup program, System Services (Unified Server Configurator [USC]), Diagnostics, and BIOS-level boot options.

UEFI Boot Settings Screen

Option	Description
Add Boot Option	Adds a new boot option.
Delete Boot Option	Deletes an existing boot option.
Enable/Disable Boot Option	Disables and enables a boot option in the boot option list.
Change Boot Order	Changes the order of the boot option list.
One-Time Boot From File	Sets a one-time boot option not included in the boot option list.

System Utilities Screen

Option	Description
System Setup	Accesses the System Setup program without rebooting.
System Services	Restarts the system and access the Lifecycle Controller, which allows you to run utilities such as system diagnostics.
BIOS Boot Manager	Accesses the BIOS-level boot options list without rebooting. This option enables you to conveniently switch to BIOS boot mode if you need to boot to a device with a non-UEFI operating system, such as a bootable DOS media with diagnostics software.
Reboot System	Restarts the system.

System and Setup Password Features

 **NOTE:** For a forgotten password, see "Disabling a Forgotten Password" on page 201.

Your system is shipped without the system password feature enabled. Operate the system only with system password protection.

 **CAUTION:** The password features provide a basic level of security for the data on your system.

 **CAUTION:** Anyone can access the data stored on your system if the system is running and unattended.

Using the System Password

When a system password is assigned, the system prompts for the system password after the system starts and only those with the password have full use of the system.

Assigning a System Password

Before assigning a system password, enter the System Setup program and check the **System Password** option.

When a system password is assigned, **System Password is Enabled**. If **Password Status is Unlocked**, you can change the system password. If **Locked**, you cannot change the system password. Disabling the password jumper on the system board sets **System Password** to **Disabled**, and you cannot change or enter a new system password.

When a system password is not assigned and the password jumper on the system board is in the enabled position, **System Password is Not Enabled and Password Status is Unlocked**. To assign a system password:

- 1 Verify that **Password Status is Unlocked**.
- 2 Highlight the **System Password** option and press < Enter > .
- 3 Type your new system password.

You can use up to 32 characters in your password.

As you type, placeholders appear in the field.

The password assignment is not case-sensitive. Certain key combinations are invalid and if you enter one, the system beeps. To erase a character, press < Backspace > or the left-arrow key.

 **NOTE:** To escape from the field without assigning a system password, press <Enter> to move to another field, or press <Esc> prior to completing step 5.

- 4 Press < Enter > .
- 5 To confirm your password, type it a second time and press < Enter > .
System Password changes to **Enabled**. Exit the System Setup program and begin using your system.
- 6 Either reboot the system now for the password protection to take effect or continue working.

 **NOTE:** Password protection does not take effect until the system reboots.

Using Your System Password to Secure Your System

 **NOTE:** If you have assigned a setup password (see "Using the Setup Password" on page 81), the system accepts your setup password as an alternate system password.

When **Password Status** is **Unlocked**, you have the option to leave the password security enabled or to disable password security.

To leave the password security enabled:

- 1 Turn on or reboot your system by pressing < Ctrl > < Alt > < Del > .
- 2 Type your password and press < Enter > .

To disable the password security:

- 1 Turn on or reboot your system by pressing < Ctrl > < Alt > < Del > .
- 2 Type your password and press < Ctrl > < Enter > .

When **Password Status** is **Locked**, you must type the password and press < Enter > when prompted at reboot.

If an incorrect system password is entered, the system displays a message and prompts you to re-enter your password. You have three attempts to enter the correct password. After the third unsuccessful attempt, the system displays an error message that the system has halted and will shut down.

Even after you shut down and restart the system, the error message continues to be displayed until the correct password is entered.



NOTE: You can use the **Password Status** option in conjunction with the **System Password** and **Setup Password** options to protect your system from unauthorized changes.

Deleting or Changing an Existing System Password

- 1 Enter the System Setup program and select the **System Security**.
- 2 Highlight **Setup Password**, press < Enter > to access the setup password window. Press < Enter > twice to clear the existing setup password.
The setting changes to **Not Enabled**.
- 3 If you want to assign a new setup password, perform the steps in "Assigning a Setup Password" on page 81.

Using the Setup Password

Assigning a Setup Password

You can assign a setup password only when the **Setup Password** is **Not Enabled**. To assign a setup password, highlight the **Setup Password** option and press the < + > or < - > key. The system prompts you to enter and verify the password.



NOTE: The setup password can be the same as the system password. If the two passwords are different, the setup password can be used as an alternate system password. The system password cannot be used in place of the setup password.

You can use up to 32 characters in your password.

As you type, placeholders appear in the field.

The password assignment is not case-sensitive. Certain key combinations are invalid and if you enter one, the system beeps. To erase a character, press < Backspace > or the left-arrow key.

When you verify the password, the **Setup Password** changes to **Enabled**. The next time you enter the System Setup program, the system prompts you for the setup password.

A change to the **Setup Password** option becomes effective immediately (restarting the system is not required).

Operating With a Setup Password Enabled

If **Setup Password** is **Enabled**, you must enter the correct setup password before modifying most of the System Setup options.

If you do not enter the correct password in three attempts, the system lets you view, but not modify, the System Setup screens. The following options are exceptions: If **System Password** is not **Enabled** and is not locked through the **Password Status** option, you can assign a system password. You cannot disable or change an existing system password.



NOTE: You can use the **Password Status** option in conjunction with the **Setup Password** option to protect the system password from unauthorized changes.

Deleting or Changing an Existing Setup Password

- 1 Enter the System Setup program and select the **System Security**.
- 2 Highlight **Setup Password**, press < Enter > to access the setup password window. Press < Enter > twice to clear the existing setup password.
The setting changes to **Not Enabled**.
- 3 If you want to assign a new setup password, perform the steps in "Assigning a Setup Password" on page 81."

Embedded System Management

The Lifecycle Controller is an embedded utility that enables systems management tasks from an embedded environment throughout the server's lifecycle.

Lifecycle Controller can be started during the boot sequence and can function independently of the operating system.



NOTE: Certain platform configurations may not support the full set of features provided by the Lifecycle Controller.

For more information about setting up the Lifecycle Controller, configuring hardware and firmware, and deploying the operating system, see the Lifecycle Controller documentation on the Dell Support website at support.dell.com/manuals.

iDRAC Configuration Utility

The iDRAC Configuration Utility is a pre-boot configuration environment that allows you to view and set parameters for the iDRAC6 and for the managed server.

The iDRAC Configuration Utility provides the following features:

- Enables fault logging and SNMP alerting
- Provides access to system event log and sensor status
- Allows control of system functions including power on and off
- Functions independently of the system's power state or the system's operating system
- Provides text console redirection for system setup, text-based utilities, and operating system consoles

In addition, the iDRAC Configuration Utility enables you to:

- Configure, enable, or disable the iDRAC6 local area network through the dedicated iDRAC6 Enterprise card port or the embedded NIC1.
- Enable or disable IPMI over LAN
- Enable a LAN Platform Event Trap (PET) destination
- Attach or detach the Virtual Media devices
- Change the administrative user name and password and manage user privileges
- View System Event Log (SEL) messages or clear messages from the log

For additional information on using iDRAC6, see the documentation for iDRAC6 and systems management applications.

Entering the iDRAC Configuration Utility

- 1 Turn on or restart your system.
- 2 Press < Ctrl> < E> when prompted during POST.

If your operating system begins to load before you press < Ctrl> < E> , allow the system to finish booting, and then restart your system and try again.

Installing System Components

Recommended Tools

You may need the following items to perform the procedures in this section:

- Key to the system keylock
- #1 and #2 Phillips screwdrivers
- T8 and T10 Torx drivers
- Wrist grounding strap

Inside the System



CAUTION: Many repairs may only be done by a certified service technician. You should only perform troubleshooting and simple repairs as authorized in your product documentation, or as directed by the online or telephone service and support team. Damage due to servicing that is not authorized by Dell is not covered by your warranty. Read and follow the safety instructions that came with the product.

Figure 3-1. Inside the System

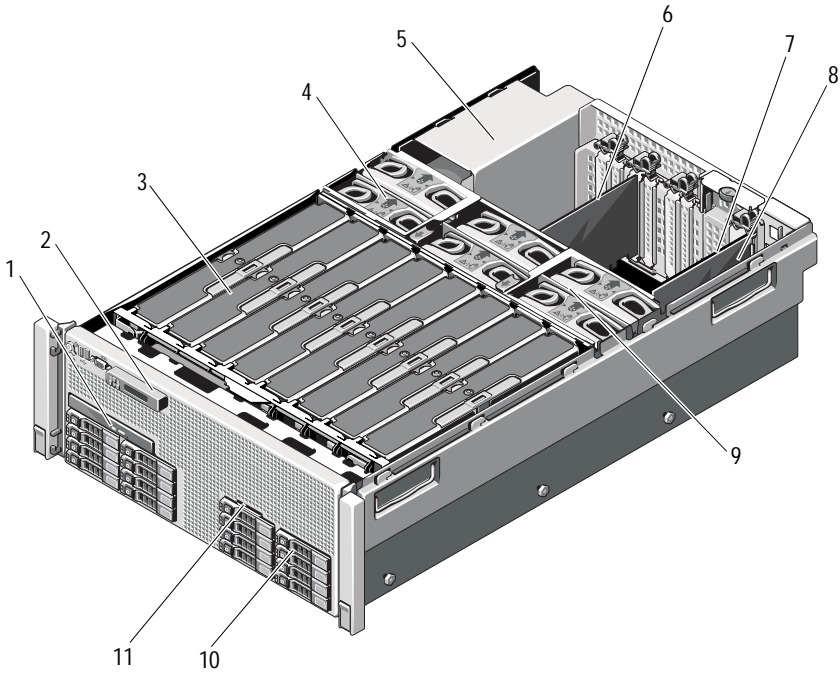

- | | | | |
|----|-----------------------------|----|------------------------------------|
| 1 | optical drive (optional) | 2 | control panel display |
| 3 | memory risers (up to 8) | 4 | cooling fans (up to 6) |
| 5 | power supply bays (4) | 6 | PCIe expansion card |
| 7 | I/O card | 8 | integrated storage controller card |
| 9 | cooling fan assembly | 10 | hard drives (up to 16) |
| 11 | system identification panel | | |

Front Bezel (Optional)

Removing the Front Bezel

- 1 Unlock the keylock at the left end of the bezel.
- 2 Lift up the release latch next to the keylock.
- 3 Rotate the left end of the bezel away from the front panel.
- 4 Unhook the right end of the bezel and pull the bezel away from the system.

Figure 3-2. Removing and Installing the Front Bezel

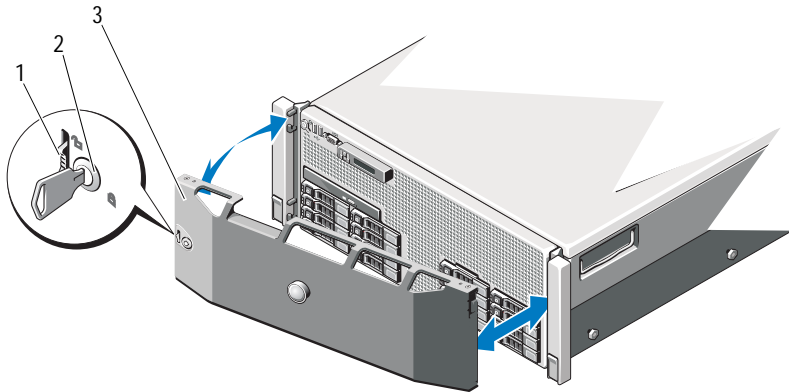

1 release latch

2 key lock

3 front bezel

Installing the Front Bezel

- 1 Hook the right end of the bezel onto the chassis.
- 2 Fit the free end of the bezel onto the system and secure the bezel with the keylock. See Figure 3-2.

System Identification Panel

Removing the System Identification Panel

- 1 If applicable, remove the front bezel. See "Removing the Front Bezel" on page 87.
- 2 Pull the system identification panel out of its slot in the chassis, until it is in the lock position. See Figure 3-3. The system identification panel is located above the hard drive slot 8.
- 3 To release the left portion of the system identification panel, pull the panel to the right until it disengages from the slot in the chassis.
- 4 To release the right portion of the system identification panel, pull the panel to the left until it disengages from the slot in the chassis.

Figure 3-3. Removing and Installing the System Identification Panel

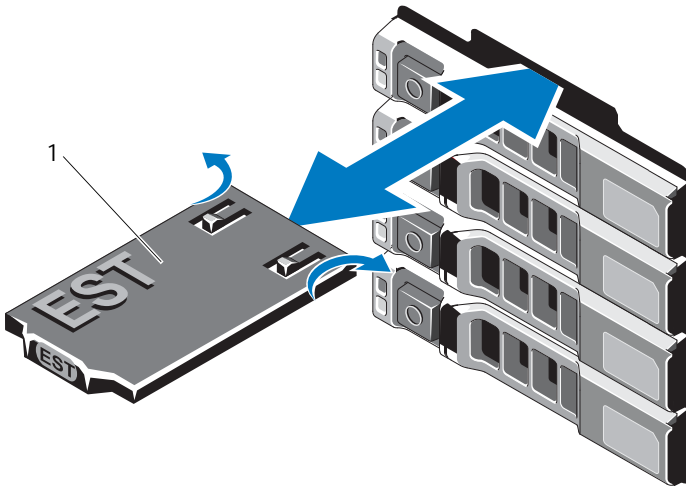



- 1 system identification panel

Installing the System Identification Panel

- 1 Align the system identification panel with the slot on the chassis.
- 2 Slide the system identification panel into the chassis, until it locks into place. See Figure 3-3.
- 3 If applicable, install the front bezel. See "Installing the Front Bezel" on page 87.

Opening and Closing the System

 **WARNING:** Whenever you need to lift the system, get others to assist you. To avoid injury, do not attempt to lift the system by yourself.

 **CAUTION:** Many repairs may only be done by a certified service technician. You should only perform troubleshooting and simple repairs as authorized in your product documentation, or as directed by the online or telephone service and support team. Damage due to servicing that is not authorized by Dell is not covered by your warranty. Read and follow the safety instructions that came with the product.

Opening the System

- 1 Turn off the system and attached peripherals, and disconnect the system from the electrical outlet and peripherals.
- 2 Rotate the latch release lock counter clockwise to the unlocked position. See Figure 3-4.
- 3 Lift up the latch and slide the cover back toward the back of the system.
- 4 Grasp the cover on both sides and lift the cover away from the system. See Figure 3-4.

Figure 3-4. Opening and Closing the System

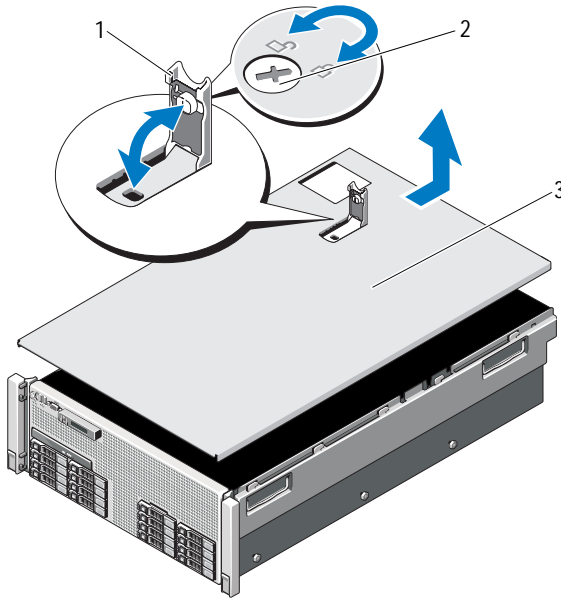

- 1 latch
- 3 cover

- 2 latch release lock

Closing the System

- 1 Place the cover onto the chassis and offset it slightly toward the back of the system, so that the chassis hooks on the back edge of the cover fit over the corresponding slots on the back edge of the chassis. See Figure 3-4.
- 2 Slide the cover toward the front of the chassis till it snaps in position.
- 3 Push down the latch to lever the cover into the closed position.
- 4 Rotate the latch release lock in a clockwise direction to secure the cover.

System Memory

Your system supports DDR3 registered DIMMs (RDIMMs). Single-, dual-, and quad-rank DIMMs can be 1067 MHz or 1333 MHz.

The system contains eight memory risers split into four sets of two risers per processor. Figure 3-5 shows the order of the memory risers in the system. Each memory riser has eight DIMM sockets arranged into four channels. The first socket of each channel is marked with white release levers.

The maximum memory that is supported on your system varies according to the sizes of memory modules being used. Single-rank, dual-rank, and quad-rank RDIMMs of sizes 1 GB, 2 GB, 4 GB, 8 GB, and 16 GB are supported for a total of up to 1 TB.

 **NOTE:** Depending on the amount of memory installed, the system may take up to 3 minutes to display video on the screen.

Figure 3-5. Memory Risers



General Memory Module Installation Guidelines

To ensure optimal performance of your system, observe the following general guidelines when configuring your system memory.

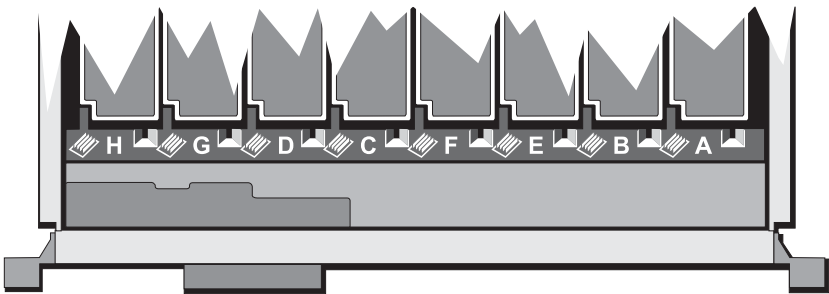

NOTE: Memory configurations that fail to observe these guidelines can prevent your system from starting and producing any video output.

- All populated memory risers must have identical configurations.
- The memory configuration for each processor must be identical for optimal performance.
- Memory modules of different sizes can be mixed (for example, 2 GB and 4 GB), but all populated channels must have identical configurations. The mixed memory configurations must be of the size $N+/-1$.
- The memory speed depends on the processor bin.
- If quad-rank memory modules are mixed with single- or dual-rank modules, the quad-rank modules must be installed in the sockets with the white release levers.
- If memory modules with different speeds are installed, they operate at the speed of the slowest installed memory module(s). The memory speeds are also dependent on the processor bin.

Two memory risers are allocated to each processor. The number of channels used and the allowable configurations depend on the memory mode selected.

The system supports memory mirroring if identical memory modules are installed in both the risers. Mirroring must be enabled in the System Setup program. In a mirrored configuration, the total available system memory is one-half of the total installed physical memory.



NOTE: Memory sparing and mirroring are enabled only when memory configurations are greater than or equal to 64 GB.

Table 3-1. Memory Configurations (Dual Processor)

		CPU 1															
Memory mode	Total memory (per processor) / total system memory	Riser A (memory capacity in GB)								Riser B (memory capacity in GB)							
		1	5	2	6	3	7	4	8	1	5	2	6	3	7	4	8
Power optimized	4 / 8	2		2						Not installed							
	8 / 16	4		4						Not installed							
	16 / 32	4		4		4		4		Not installed							
	32 / 64	4	4	4	4	4	4	4	4	Not installed							
Performance optimized	4 / 8	1		1						1		1					
	8 / 16	1		1		1		1		1		1		1		1	
	16 / 32	2		2		2		2		2		2		2		2	
	32 / 64	4		4		4		4		4		4		4		4	
Power and performance optimized	2 / 4	1		1						Not installed							
	64 / 128	4	4	4	4	4	4	4	4	4	4	4	4	4	4	4	4
	80 / 160	8	8	4	4	4	4	4	4	8	8	4	4	4	4	4	4
	128 / 256	8	8	8	8	8	8	8	8	8	8	8	8	8	8	8	8

CPU 2

Memory mode	Total memory (per processor) / total system memory	Riser A (memory capacity in GB)								Riser B (memory capacity in GB)							
		1	5	2	6	3	7	4	8	1	5	2	6	3	7	4	8
Power optimized	4 / 8	2		2						Not installed							
	8 / 16	4		4						Not installed							
	16 / 32	4		4		4		4		Not installed							
	32 / 64	4	4	4	4	4	4	4	4	Not installed							
Performance optimized	4 / 8	1		1						1		1					
	8 / 16	1		1		1		1		1		1		1		1	
	16 / 32	2		2		2		2		2		2		2		2	
	32 / 64	4		4		4		4		4		4		4		4	
Power and performance optimized	2 / 4	1		1						Not installed							
	64 / 128	4	4	4	4	4	4	4	4	4	4	4	4	4	4	4	4
	80 / 160	8	8	4	4	4	4	4	4	8	8	4	4	4	4	4	4
	128 / 256	8	8	8	8	8	8	8	8	8	8	8	8	8	8	8	8

Table 3-2. Memory Configurations (Four Processors)

CPU 1																	
Memory mode	Total memory (per processor) / total system memory	Riser A (memory capacity in GB)								Riser B (memory capacity in GB)							
		1	5	2	6	3	7	4	8	1	5	2	6	3	7	4	8
Power optimized	4 / 16	2		2						Not installed							
	8 / 32	4		4						Not installed							
	16 / 64	4		4		4		4		Not installed							
	32 / 128	4	4	4	4	4	4	4	4	Not installed							
	40 / 160	8	8	4	4	4	4	4	4	Not installed							
	48 / 192	8	8	8	8	4	4	4	4	Not installed							
Performance optimized	4 / 16	1		1						1		1					
	8 / 32	1		1		1		1		1		1		1		1	
	16 / 64	2		2		2		2		2		2		2		2	
	32 / 128	4		4		4		4		4		4		4		4	
	48 / 192	8		8		4		4		8		8		4		4	
Power and performance optimized	2 / 8	1		1						Not installed							
	64 / 256	4	4	4	4	4	4	4	4	4	4	4	4	4	4	4	4
	128 / 512	8	8	8	8	8	8	8	8	8	8	8	8	8	8	8	8
	256 / 1024	16	16	16	16	16	16	16	16	16	16	16	16	16	16	16	16
Expandability	32 / 128	8		8						8		8					
	64 / 256	8		8		8		8		8		8		8		8	
	128 / 512	16		16		16		16		16		16		16		16	

CPU 2

Memory mode	Total memory (per processor) / total system memory	Riser A (memory capacity in GB)								Riser B (memory capacity in GB)							
		1	5	2	6	3	7	4	8	1	5	2	6	3	7	4	8
Power optimized	4 / 16	2		2						Not installed							
	8 / 32	4		4						Not installed							
	16 / 64	4		4		4		4		Not installed							
	32 / 128	4	4	4	4	4	4	4	4	Not installed							
	40 / 160	8	8	4	4	4	4	4	4	Not installed							
	48 / 192	8	8	8	8	4	4	4	4	Not installed							
Performance optimized	4 / 16	1		1						1		1					
	8 / 32	1		1		1		1		1		1		1		1	
	16 / 64	2		2		2		2		2		2		2		2	
	32 / 128	4		4		4		4		4		4		4		4	
	48 / 192	8		8		4		4		8		8		4		4	
Power and performance optimized	2 / 8	1		1						Not installed							
	64 / 256	4	4	4	4	4	4	4	4	4	4	4	4	4	4	4	4
	128 / 512	8	8	8	8	8	8	8	8	8	8	8	8	8	8	8	8
	256 / 1024	16	16	16	16	16	16	16	16	16	16	16	16	16	16	16	16
Expandability	32 / 128	8		8						8		8					
	64 / 256	8		8		8		8		8		8		8		8	
	128 / 512	16		16		16		16		16		16		16		16	

CPU 3

Memory mode	Total memory (per processor) / total system memory	Riser A (memory capacity in GB)								Riser B (memory capacity in GB)							
		1	5	2	6	3	7	4	8	1	5	2	6	3	7	4	8
Power optimized	4 / 16	2		2						Not installed							
	8 / 32	4		4						Not installed							
	16 / 64	4		4		4		4		Not installed							
	32 / 128	4	4	4	4	4	4	4	4	Not installed							
	40 / 160	8	8	4	4	4	4	4	4	Not installed							
	48 / 192	8	8	8	8	4	4	4	4	Not installed							
Performance optimized	4 / 16	1		1						1		1					
	8 / 32	1		1		1		1		1		1		1		1	
	16 / 64	2		2		2		2		2		2		2		2	
	32 / 128	4		4		4		4		4		4		4		4	
	48 / 192	8		8		4		4		8		8		4		4	
Power and performance optimized	2 / 8	1		1						Not installed							
	64 / 256	4	4	4	4	4	4	4	4	4	4	4	4	4	4	4	4
	128 / 512	8	8	8	8	8	8	8	8	8	8	8	8	8	8	8	8
	256 / 1024	16	16	16	16	16	16	16	16	16	16	16	16	16	16	16	16
Expandability	32 / 128	8		8						8		8					
	64 / 256	8		8		8		8		8		8		8		8	
	128 / 512	16		16		16		16		16		16		16		16	

CPU 4

Memory mode	Total memory (per processor) / total system memory	Riser A (memory capacity in GB)								Riser B (memory capacity in GB)							
		1	5	2	6	3	7	4	8	1	5	2	6	3	7	4	8
Power optimized	4 / 16	2		2						Not installed							
	8 / 32	4		4						Not installed							
	16 / 64	4		4		4		4		Not installed							
	32 / 128	4	4	4	4	4	4	4	4	Not installed							
	40 / 160	8	8	4	4	4	4	4	4	Not installed							
	48 / 192	8	8	8	8	4	4	4	4	Not installed							
Performance optimized	4 / 16	1		1						1		1					
	8 / 32	1		1		1		1		1		1		1		1	
	16 / 64	2		2		2		2		2		2		2		2	
	32 / 128	4		4		4		4		4		4		4		4	
	48 / 192	8		8		4		4		8		8		4		4	
Power and performance optimized	2 / 8	1		1						Not installed							
	64 / 256	4	4	4	4	4	4	4	4	4	4	4	4	4	4	4	4
	128 / 512	8	8	8	8	8	8	8	8	8	8	8	8	8	8	8	8
	256 / 1024	16	16	16	16	16	16	16	16	16	16	16	16	16	16	16	16
Expandability	32 / 128	8		8						8		8					
	64 / 256	8		8		8		8		8		8		8		8	
	128 / 512	16		16		16		16		16		16		16		16	

Removing a Memory-Riser Blank

△ CAUTION: Many repairs may only be done by a certified service technician. You should only perform troubleshooting and simple repairs as authorized in your product documentation, or as directed by the online or telephone service and support team. Damage due to servicing that is not authorized by Dell is not covered by your warranty. Read and follow the safety instructions that came with the product.

- 1 Turn off the system, including any attached peripherals, and disconnect the system from the electrical outlet.
- 2 Open the system. See "Opening the System" on page 89.
- 3 Press the release tabs toward each other and lift the memory-riser blank out of the system.

Figure 3-6. Removing and Installing a Memory-Riser Blank

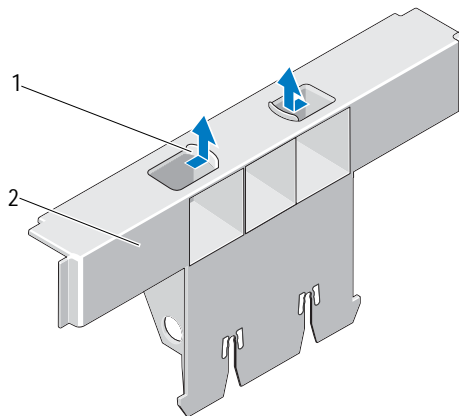

1 release tabs (2)

2 memory-riser blank

Installing a Memory-Riser Blank

 **CAUTION:** Many repairs may only be done by a certified service technician. You should only perform troubleshooting and simple repairs as authorized in your product documentation, or as directed by the online or telephone service and support team. Damage due to servicing that is not authorized by Dell is not covered by your warranty. Read and follow the safety instructions that came with the product.

- 1 Align the memory-riser blank with the slots on the memory-riser guide and the cooling fan assembly.
- 2 Insert the memory-riser blank firmly into the card guide until it is fully seated.
- 3 Close the system. See "Closing the System" on page 90.
- 4 Reconnect the system to its electrical outlet and turn the system on, including any attached peripherals.

Removing a Memory Riser

 **CAUTION:** Many repairs may only be done by a certified service technician. You should only perform troubleshooting and simple repairs as authorized in your product documentation, or as directed by the online or telephone service and support team. Damage due to servicing that is not authorized by Dell is not covered by your warranty. Read and follow the safety instructions that came with the product.

- 1 Turn off the system, including any attached peripherals, and disconnect the system from the electrical outlet.
- 2 Open the system. See "Opening the System" on page 89.
- 3 Press the release button on the memory riser to release the handle.
- 4 Grasp the handle and lift the memory riser out of the system.

 **CAUTION:** To maintain proper system cooling, all empty memory-riser slots must have memory-riser blanks installed.

- 5 Install a memory-riser blank. See "Installing a Memory-Riser Blank" on page 100.
- 6 Close the system. See "Closing the System" on page 90.
- 7 Reconnect the system to its electrical outlet and turn the system on, including any attached peripherals.

Figure 3-7. Removing and Installing a Memory Riser

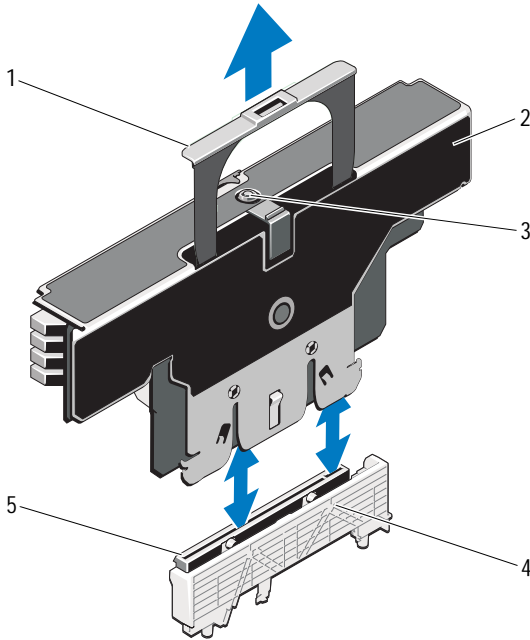

- | | | | |
|---|------------------------|---|--------------|
| 1 | handle | 2 | memory riser |
| 3 | release button | 4 | card guide |
| 5 | memory-riser connector | | |

Installing a Memory Riser

- 1 Turn off the system, including any attached peripherals, and disconnect the system from the electrical outlet.
- 2 Open the system. See "Opening the System" on page 89.
- 3 If applicable, remove the memory-riser blank. See "Removing a Memory-Riser Blank" on page 99.

△ CAUTION: Before installing the memory riser, you must ensure that the memory module socket ejectors are in the locked position.

- 4 Align the memory riser with the slots on the memory-riser guide and the cooling fan assembly.
- 5 Insert the memory riser firmly into the card guide until it is fully seated.
- 6 Press down on the handle until it clicks into place.
 -  **NOTE:** You can only lower the handle after the memory riser is seated in the card guide. If the handle does not move down, verify that the memory riser is properly seated in the card guide.
- 7 Close the system. See "Closing the System" on page 90.
- 8 Reconnect the system to its electrical outlet and turn the system on, including any attached peripherals.

Installing Memory Modules



WARNING: The memory modules are hot to the touch for some time after the system has been powered down. Allow time for the memory modules to cool before handling them. Handle the memory modules by the card edges and avoid touching the components on the memory module.



CAUTION: Many repairs may only be done by a certified service technician. You should only perform troubleshooting and simple repairs as authorized in your product documentation, or as directed by the online or telephone service and support team. Damage due to servicing that is not authorized by Dell is not covered by your warranty. Read and follow the safety instructions that came with the product.

- 1 Turn off the system, including any attached peripherals, and disconnect the system from the electrical outlet.
- 2 Open the system. See "Opening the System" on page 89.
- 3 Remove the memory risers. See "Removing a Memory Riser" on page 100.
- 4 Pull the release tab and lift the memory module cover in the direction of the arrow.

Figure 3-8. Removing and Installing the Memory Module Cover

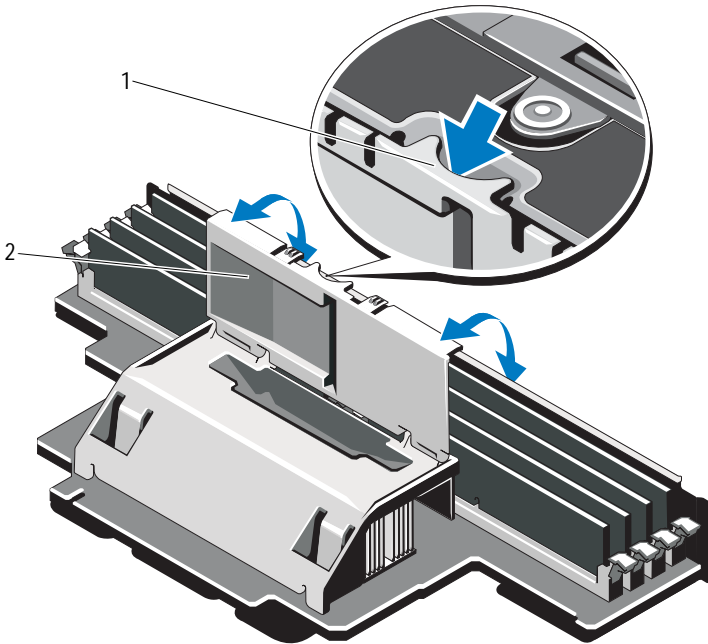

1 release tab

2 memory module cover

△ **CAUTION:** Handle each memory module only on either card edge, making sure not to touch the middle of the memory module.

- 5 Press the ejectors on the memory module socket down and out, as shown in Figure 3-9.

Figure 3-9. Installing and Removing a Memory Module

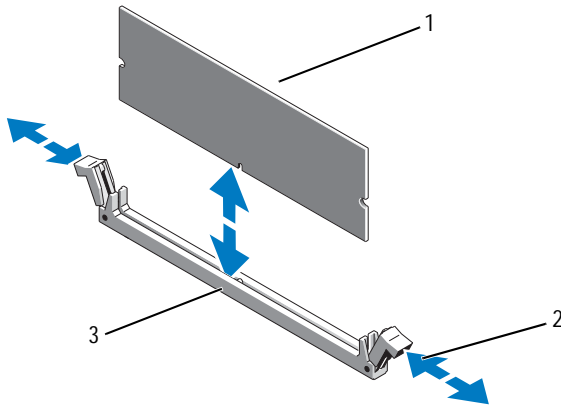

- 1 memory module
- 2 memory module socket ejectors (2)
- 3 alignment key

6 Align the memory module's edge connector with the alignment key of the memory module socket, and insert the memory module in the socket.

NOTE: The memory module socket has an alignment key that allows you to install the memory module in the socket in only one way.

7 Press down on the memory module with your thumbs to lock the memory module into the socket.

When the memory module is properly seated in the socket, the ejectors on the memory module socket align with the ejectors on the other sockets that have memory modules installed.

8 Repeat step 5 through step 7 of this procedure to install the remaining memory modules. See Table 3-1 and Table 3-2.





9 Close the memory module cover.

10 Install the memory risers. See "Installing a Memory Riser" on page 101.

11 Close the system. See "Closing the System" on page 90.

- 12 Reconnect the system to its electrical outlet and turn the system on, including any attached peripherals.
- 13 Press < F2 > to enter the System Setup program, and check the **System Memory** setting on the main **System Setup** screen.
The system should have already changed the value to reflect the newly installed memory.
- 14 If the value is incorrect, one or more of the memory modules may not be installed properly. Repeat step 2 through step 13 of this procedure to ensure that the memory modules are firmly seated in their sockets.
- 15 Run the system memory test in the system diagnostics. See "Running the Embedded System Diagnostics" on page 194.

Removing Memory Modules

-  **WARNING:** The memory modules are hot to the touch for some time after the system has been powered down. Allow time for the memory modules to cool before handling them. Handle the memory modules by the card edges and avoid touching the components on the memory module.
-  **CAUTION:** Many repairs may only be done by a certified service technician. You should only perform troubleshooting and simple repairs as authorized in your product documentation, or as directed by the online or telephone service and support team. Damage due to servicing that is not authorized by Dell is not covered by your warranty. Read and follow the safety instructions that came with the product.
-  **CAUTION:** To ensure proper system cooling, memory-module blanks must be installed in any memory socket that is not occupied. Remove memory-module blanks only if you intend to install memory modules in those sockets.
 - 1 Turn off the system, including any attached peripherals, and disconnect the system from the electrical outlet.
 - 2 Open the system. See "Opening the System" on page 89.
 - 3 Remove the memory risers. See "Removing a Memory Riser" on page 100.
 - 4 Press the tabs in the direction of the arrows and lift the memory module cover.
-  **CAUTION:** Handle each memory module only on either card edge, making sure not to touch the middle of the memory module.

- 5 Press down and out on the ejectors on each end of the socket until the memory module pops out of the socket. See Figure 3-9.
- 6 Close the memory module cover.
- 7 Install the memory risers. See "Installing a Memory Riser" on page 101.
- 8 Close the system. See "Closing the System" on page 90.
- 9 Reconnect the system and peripherals to their power sources, and turn them on.

Removing the Memory-Riser Guide

- 1 Turn off the system, including any attached peripherals, and disconnect the system from the electrical outlet.
- 2 Open the system. See "Opening the System" on page 89.
- 3 If applicable, remove the memory-riser blanks. See "Removing a Memory-Riser Blank" on page 99.
- 4 Remove the memory risers. See "Removing a Memory Riser" on page 100.
- 5 Press the tabs in the direction of the arrows and lift the memory-riser guide out of the system.

Figure 3-10. Removing or Installing the Memory-Riser Guide

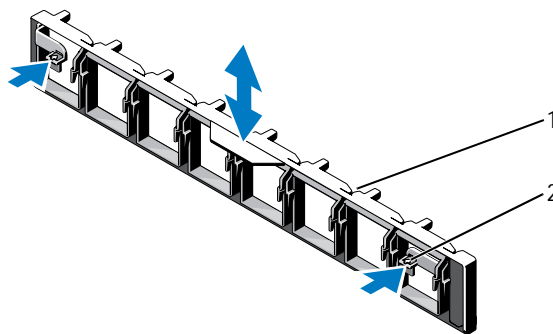

1 memory-riser guide

2 tabs (2)

Installing the Memory-Riser Guide

- 1 Align the memory-riser guide with the slots on the chassis.
- 2 Lower the memory-riser guide into the system until the tabs click into place.
- 3 Install the memory risers. See "Installing a Memory Riser" on page 101.
- 4 If applicable, install the memory-riser blanks. See "Installing a Memory-Riser Blank" on page 100.
- 5 Close the system. See "Closing the System" on page 90.
- 6 Reconnect the system and peripherals to their power sources, and turn them on.

Hard Drives

All drives connect to the system board through the SAS/SATA backplane board. Hard drives are supplied in special hot-swappable drive carriers that fit in the hard-drive bays.



CAUTION: Before attempting to remove or install a drive while the system is running, see the documentation for the SAS controller card to ensure that the host adapter is configured correctly to support hot-swap drive removal and insertion.



CAUTION: Do not turn off or reboot your system while the drive is being formatted. Doing so can cause a drive failure.



NOTE: Use only drives that have been tested and approved for use with the SAS/SATA backplane board.

When you format a hard drive, allow enough time for the formatting to be completed. Be aware that high-capacity hard drives can take a number of hours to format.

Removing a Hard-Drive Blank

CAUTION: To maintain proper system cooling, all empty hard-drive bays must have drive blanks installed.

- 1 Turn off the system, including any attached peripherals, and disconnect the system from its electrical outlet.
- 2 If installed, remove the front bezel. See "Removing the Front Bezel" on page 87.
- 3 Press the release tab and slide the drive blank out until it is free of the drive bay. See Figure 3-11.

Figure 3-11. Removing or Installing a Hard-Drive Blank

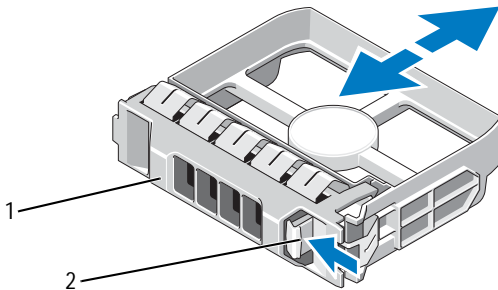

1 hard-drive blank

2 release tab

Installing a Hard-Drive Blank

- 1 If installed, remove the front bezel. See "Removing the Front Bezel" on page 87.
- 2 Insert the drive blank into the drive bay until the blue release tab clicks into place.
- 3 If applicable, install the front bezel. See "Installing the Front Bezel" on page 87.

Removing a Hard Drive

 **CAUTION:** Ensure that your operating system supports hot-swap drive installation. See the documentation supplied with the operating system.

- 1 If installed, remove the front bezel. See "Removing the Front Bezel" on page 87.
- 2 From the management software, prepare the drive for removal. Wait until the hard-drive indicators on the drive carrier signal that the drive can be removed safely. See your controller documentation for information about hot-swap drive removal.

If the drive has been online, the green activity/fault indicator flashes as the drive is powered down. When the drive indicators are off, the drive is ready for removal.

- 3 Open the drive carrier release handle to release the drive. See Figure 3-12.
- 4 Slide the hard drive out until it is free of the drive bay.

 **CAUTION:** To maintain proper system cooling, all empty hard-drive bays must have drive blanks installed.

- 5 Insert a drive blank in the empty drive bay. See "Installing a Hard-Drive Blank" on page 108.
- 6 If applicable, install the front bezel. See "Installing the Front Bezel" on page 87.

Figure 3-12. Removing and Installing a Hard Drive

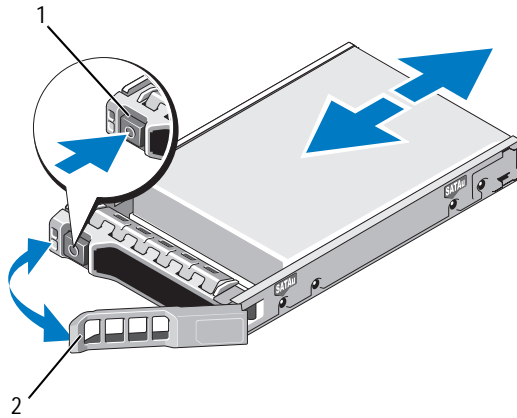

1 release button

2 hard drive carrier handle

Installing a Hard Drive

- △ **CAUTION:** Use only hard drives that have been tested and approved for use with the SAS/SATA backplane.
- △ **CAUTION:** When installing a hard drive, ensure that the adjacent drives are fully installed. Inserting a hard-drive carrier and attempting to lock its handle next to a partially installed carrier can damage the partially installed carrier's shield spring and make it unusable.
- △ **CAUTION:** Ensure that your operating system supports hot-swap drive installation. See the documentation supplied with your operating system.
- △ **CAUTION:** Combining SATA and SAS hard drives in the same system configuration is not supported.

- 1 If installed, remove the front bezel. See "Removing the Front Bezel" on page 87.
- 2 If a drive blank is present in the bay, remove it. See "Removing a Hard-Drive Blank" on page 108.
- 3 Press the button on the front of the drive carrier and open the handle.
- 4 Insert the hard-drive carrier into the drive bay until the carrier contacts the backplane.

5 Close the handle to lock the drive in place.

Removing a Hard Drive From a Hard-Drive Carrier

Remove the screws from the slide rails on the hard-drive carrier and separate the hard drive from the carrier. See Figure 3-13.

Figure 3-13. Removing or Installing a Hot-Swap Hard Drive Into a Drive Carrier

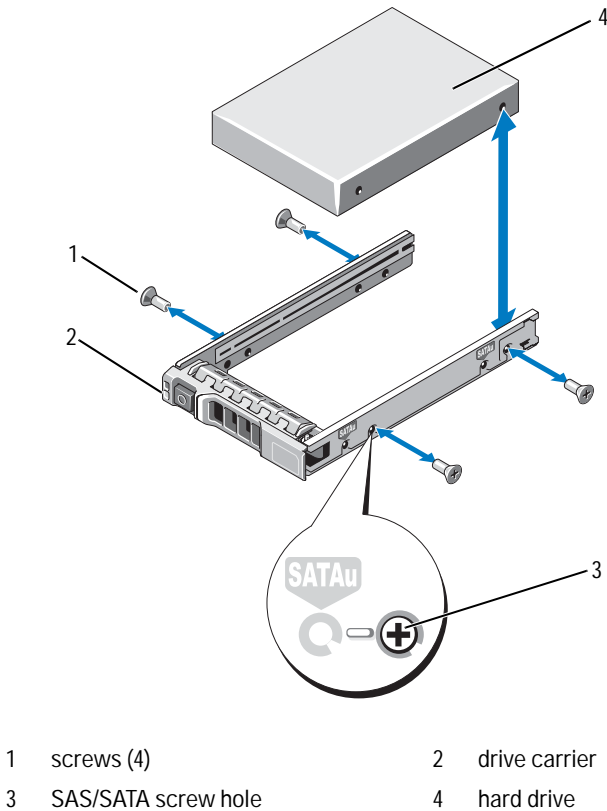

Installing a Hard Drive Into a Drive Carrier

- 1 Insert the hard drive into the hard-drive carrier with the connector end of the drive at the rear. See Figure 3-13.
- 2 Align the screw holes on the hard drive with the back set of holes on the hard drive carrier.

When aligned correctly, the back of the hard drive will be flush with the back of the hard-drive carrier.

- 3 Attach the four screws to secure the hard drive to the hard-drive carrier.

Optical Drive

An optional DVD +/-RW optical drive slides into the front panel and connects to the SATA controller on the system board.



NOTE: DVD devices are data only.

Removing an Optical Drive



CAUTION: Many repairs may only be done by a certified service technician. You should only perform troubleshooting and simple repairs as authorized in your product documentation, or as directed by the online or telephone service and support team. Damage due to servicing that is not authorized by Dell is not covered by your warranty. Read and follow the safety instructions that came with the product.

- 1 If installed, remove the front bezel. See "Removing the Front Bezel" on page 87.
- 2 Turn off the system, including any attached peripherals, and disconnect the system from its electrical outlet.
- 3 Open the system. See "Opening the System" on page 89.
- 4 If applicable, remove the memory risers H, G, and D. See "Removing a Memory Riser" on page 100. For the location of memory risers H, G, and D on the system, see Figure 3-5.
- 5 Disconnect the power/data cable from the back of the drive.

Note the routing of the power/data cable on the side on the system as you remove them from the system board and drive. You must route these cables properly when you replace them to prevent them from being pinched or crimped.

- 6 To remove the drive, press down and push the blue release tab toward the front of the system. See Figure 3-14.
- 7 Slide the optical drive out of the system until it is free of the drive bay.
- 8 If you are not adding a new optical drive, install the optical drive insert.
- 9 If applicable, install the memory risers H, G, and D. See "Installing a Memory Riser" on page 101.
- 10 Close the system. See "Closing the System" on page 90.
- 11 Reconnect the system to its electrical outlet and turn the system on, including any attached peripherals.
- 12 If applicable, install the front bezel. See "Installing the Front Bezel" on page 87.

Figure 3-14. Removing the Optical Drive

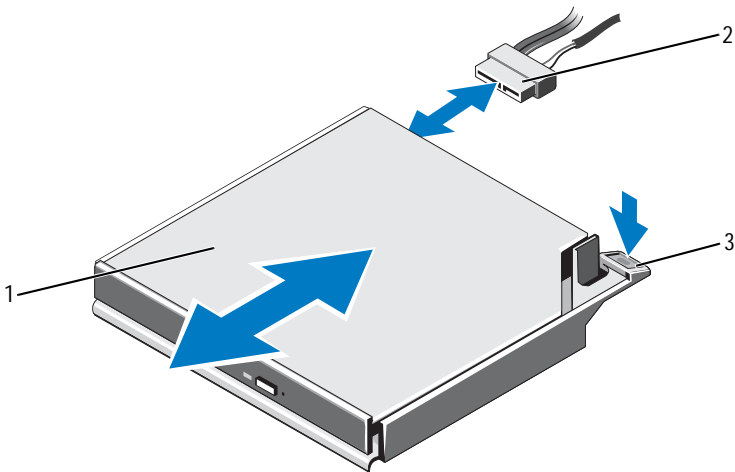

- 1 optical drive
- 3 release tab

- 2 power/data cable

Installing an Optical Drive



CAUTION: Many repairs may only be done by a certified service technician. You should only perform troubleshooting and simple repairs as authorized in your product documentation, or as directed by the online or telephone service and support team. Damage due to servicing that is not authorized by Dell is not covered by your warranty. Read and follow the safety instructions that came with the product.

- 1 If installed, remove the front bezel. See "Removing the Front Bezel" on page 87.
- 2 Turn off the system, including any attached peripherals, and disconnect the system from its electrical outlet.
- 3 Open the system. See "Opening the System" on page 89.
- 4 If applicable, remove the memory risers H, G, and D. See "Removing a Memory Riser" on page 100.
- 5 Slide the optical drive into the optical drive bay until the blue release tab snaps into place. See Figure 3-14.
- 6 Connect the power/data cable to the back of the drive.
You must route the cable properly on the side of system to prevent it from being pinched or crimped.
- 7 If not already done, connect the power cable to SATA_PWR and the interface cable to SATA_A connector on the system board. See Figure 6-1.
- 8 If applicable, install the memory risers H, G, and D. See "Installing a Memory Riser" on page 101. For the location of memory risers H, G, and D on the system, see Figure 3-5.
- 9 Close the system. See "Closing the System" on page 90.
- 10 Reconnect the system and peripherals to their electrical outlets.
- 11 If applicable, install the front bezel. See "Installing the Front Bezel" on page 87.

Cooling Fans

Your system contains six single-rotor hot-swappable fans to provide cooling for the processors, expansion cards, and memory modules.

 **NOTE:** In the event of a problem with a particular fan, the fan number is referenced by the system's management software, allowing you to easily identify and replace the proper fan by noting the fan numbers on the fan assembly.

Removing a Cooling Fan

 **WARNING:** The cooling fan can continue to spin for some time after it has been powered down. Allow time for the fan to stop spinning before removing it from the system.

 **WARNING:** Do not attempt to operate the system without the cooling fans or the cover.

 **CAUTION:** Many repairs may only be done by a certified service technician. You should only perform troubleshooting and simple repairs as authorized in your product documentation, or as directed by the online or telephone service and support team. Damage due to servicing that is not authorized by Dell is not covered by your warranty. Read and follow the safety instructions that came with the product.

 **NOTE:** The procedure for removing each individual fan module is the same.

- 1 Open the system. See "Opening the System" on page 89.
- 2 Press the release tabs toward each other and lift the fan out of the fan assembly. See Figure 3-15.

Figure 3-15. Removing and Installing a Cooling Fan

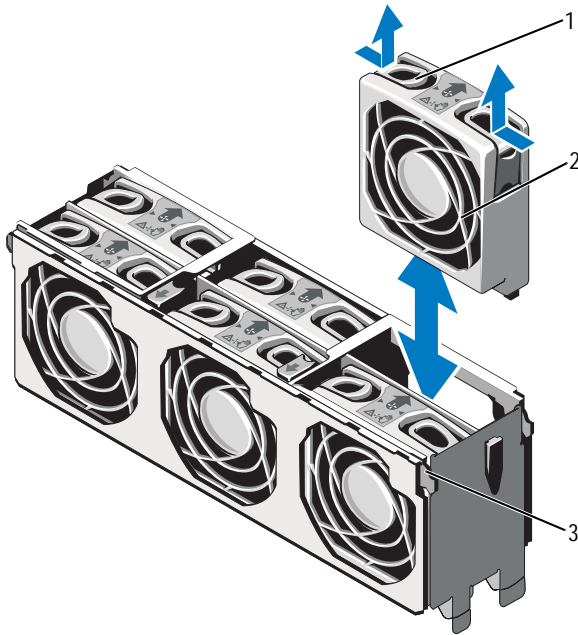

- 1 release tab (2)
- 2 cooling fan
- 3 cooling fan assembly

Installing a Cooling Fan

CAUTION: Many repairs may only be done by a certified service technician. You should only perform troubleshooting and simple repairs as authorized in your product documentation, or as directed by the online or telephone service and support team. Damage due to servicing that is not authorized by Dell is not covered by your warranty. Read and follow the safety instructions that came with the product.

- 1 Align the connector on the fan with the connector on the system board.
- 2 Lower the fan into the fan assembly until the release tabs snap into place. See Figure 3-15.
- 3 Close the system. See "Closing the System" on page 90.

Removing the Cooling Fan Assembly



CAUTION: Many repairs may only be done by a certified service technician. You should only perform troubleshooting and simple repairs as authorized in your product documentation, or as directed by the online or telephone service and support team. Damage due to servicing that is not authorized by Dell is not covered by your warranty. Read and follow the safety instructions that came with the product.

- 1 Turn off the system, including any attached peripherals, and disconnect the system from its electrical outlet.
- 2 Open the system. See "Opening the System" on page 89.
- 3 If applicable, remove the memory-riser blanks. See "Removing a Memory-Riser Blank" on page 99.
- 4 Remove the memory risers. See "Removing a Memory Riser" on page 100.
- 5 Remove the fans from the cooling fan assembly. See "Removing a Cooling Fan" on page 115.
- 6 Pull the blue release tabs in the direction of the arrows to release the handles on the cooling fan assembly. See Figure 3-16.
- 7 Grasp the handles and lift the cooling fan assembly out of the system. See Figure 3-16.

Figure 3-16. Removing and Installing the Fan Assembly

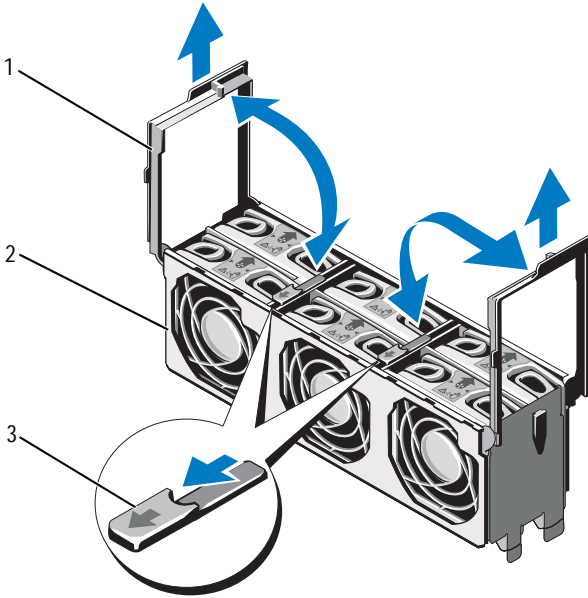

1 handles (2)

2 cooling fan assembly

3 release tabs (2)

Installing the Cooling Fan Assembly



CAUTION: Many repairs may only be done by a certified service technician. You should only perform troubleshooting and simple repairs as authorized in your product documentation, or as directed by the online or telephone service and support team. Damage due to servicing that is not authorized by Dell is not covered by your warranty. Read and follow the safety instructions that came with the product.

- 1 Align the tabs on the cooling fan assembly with the slots on the system. See Figure 3-16.



NOTE: You must also ensure that the pins on the bottom of the cooling fan assembly are aligned with the holes on the system board.

- 2 Insert the cooling fan assembly into the system and lower the handles to lock it in place.
- 3 Install the cooling fans. See "Installing the Cooling Fan Assembly" on page 119.
- 4 Install the memory risers. See "Installing a Memory Riser" on page 101.
- 5 If applicable, install the memory-riser blanks. See "Installing a Memory-Riser Blank" on page 100.
- 6 Close the system. See "Closing the System" on page 90.
- 7 Reconnect the system to its electrical outlet and turn the system on, including any attached peripherals.

Internal USB Memory Key

An optional USB memory key installed inside your system can be used as a boot device, security key, or mass storage device. The USB connector must be enabled by the **Internal USB Port** option in the **Integrated Devices** screen of the System Setup program.

To boot from the USB memory key, configure the USB memory key with a boot image and then specify the USB memory key in the boot sequence in the System Setup program.

 **CAUTION:** Many repairs may only be done by a certified service technician. You should only perform troubleshooting and simple repairs as authorized in your product documentation, or as directed by the online or telephone service and support team. Damage due to servicing that is not authorized by Dell is not covered by your warranty. Read and follow the safety instructions that came with the product.

- 1 Turn off the system, including any attached peripherals, and disconnect the system from the electrical outlet.
- 2 Open the system. See "Opening the System" on page 89.
- 3 Locate the USB connector on the system board.
- 4 Insert the USB memory key into the USB connector. See Figure 3-17.
- 5 Close the system. See "Closing the System" on page 90.
- 6 Reconnect the system to its electrical outlet and turn the system on, including any attached peripherals.
- 7 Enter the System Setup program and verify that the USB key has been detected by the system. See "Using the System Setup Program and UEFI Boot Manager" on page 63.

Figure 3-17. Removing and Installing a USB Memory Key

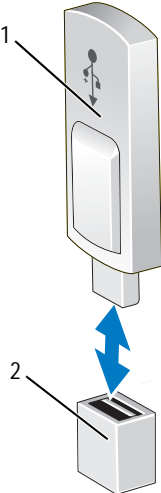



1 USB memory key

2 USB memory key connector

Integrated NIC Hardware Key

TCP/IP Offload Engine (TOE) and iSCSI are enabled by default on the system. The integrated NIC hardware key is reserved for future use.

 **CAUTION:** Many repairs may only be done by a certified service technician. You should only perform troubleshooting and simple repairs as authorized in your product documentation, or as directed by the online or telephone service and support team. Damage due to servicing that is not authorized by Dell is not covered by your warranty. Read and follow the safety instructions that came with the product.

 **NOTE:** TOE operating system support and the Microsoft® scalable network pack are required for TOE functionality.

- 1 Turn off the system, including any attached peripherals, and disconnect the system from its electrical outlet.
- 2 Open the system. See "Opening the System" on page 89.
- 3 Locate the iSCSI_KEY connector on the system board. See Figure 6-1.
- 4 Insert the NIC hardware key into the connector onto the board. See Figure 3-18.

Figure 3-18. Removing or Installing a NIC Hardware Key

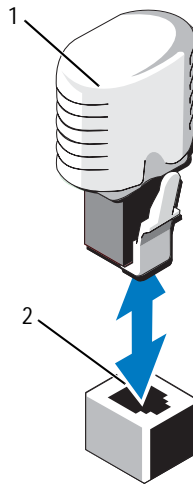

1 NIC hardware key

2 iSCSI_KEY connector

- 5 Close the system. See "Closing the System" on page 90.
- 6 Reconnect the system to its electrical outlet and turn the system on, including any attached peripherals.

Expansion Cards and Expansion-Card Riser

Expansion Card Installation Guidelines

Your system supports one Generation 1 PCIe expansion card and up to six Generation 2 PCIe expansion cards.

- The expansion slot supports full-height, half-length cards.
- The expansion-card slot is not hot-swappable.
- PCI Express Generation 2 slots support both PCI Express Generation 1 and PCI Express Generation 2 cards. However, using a PCI Express Generation 2 card on an PCI Express Generation 1 slot may impact performance of the card.

- PCI Express Generation 1 is supported on slot 5 and Generation 2 expansion cards are supported in the slots 1, 2, 3, 4, 6, and 7.
- Slot 7 can be expanded to four additional PCIe x4 Generation 2 low profile slots using an optional PCIe expansion riser.
- Table 3-3 provides a guide for installing expansion cards to ensure proper cooling and mechanical fit. The expansion cards with the highest priority should be installed first using the slot priority indicated. All other expansion cards should be installed in card priority and slot priority order.

Table 3-3. Expansion-Card Installation Order

Card Priority	Card Type	Slot Priority Without a PCIe Riser	Slot Priority With a PCIe Riser	Max Allowed
1	PERC H800	2, 3, 4, 6, 7, 1	2, 3, 4, 6, 1	2
2	6 Gbps SAS HBA	2, 3, 4, 6, 7, 1	2, 3, 4, 6, 1	2
3	SAS 5/E Adapter	2, 3, 4, 6, 7	2, 3, 4, 6	2
4	10 Gb NICs	2, 3, 4, 6, 7	2, 3, 4, 6	2
5	8G Fiber Channel (single port)	1, 2, 3, 4, 6, 7	1, 7, 8, 9, 10, 2, 3, 4, 6	4
6	8G Fiber Channel (dual port)	2, 3, 4, 6, 7	2, 3, 4, 6	2
7	4G Fibre Channel	5, 1, 2, 3, 4, 6, 7	5, 1, 7, 8, 9, 10, 2, 3, 4, 6	4-6
8	SCSI HBA	5, 1, 2, 3, 4, 6, 7	5, 1, 7, 8, 9, 10, 2, 3, 4, 6	2
9	1 Gb NICs (Generation 1 adapters)	5, 1, 2, 3, 4, 6, 7, 1	5, 1, 7, 8, 9, 10, 2, 3, 4, 6	10
10	1 Gb NICs (Generation 2 adapters)	5, 1, 2, 3, 4, 6, 7, 1	1, 7, 8, 9, 10, 5, 2, 3, 4, 6	10

Installing an Expansion Card



CAUTION: Many repairs may only be done by a certified service technician. You should only perform troubleshooting and simple repairs as authorized in your product documentation, or as directed by the online or telephone service and support team. Damage due to servicing that is not authorized by Dell is not covered by your warranty. Read and follow the safety instructions that came with the product.

- 1 Unpack the expansion card and prepare it for installation.
For instructions, see the documentation accompanying the card.
- 2 Turn off the system, including any attached peripherals, and disconnect the system from the electrical outlet.
- 3 Open the system. See "Opening the System" on page 89.
- 4 Open the expansion-card latch and remove the filler bracket. See Figure 3-19.
- 5 Holding the card by its edges, position the card so that the card-edge connector aligns with the expansion-card connector.
- 6 Insert the card-edge connector firmly into the expansion-card connector until the card is fully seated.
- 7 Close the expansion-card latch. See Figure 3-19.
- 8 If applicable, install the screw to secure the expansion card to the system.

Figure 3-19. Installing or Removing an Expansion Card

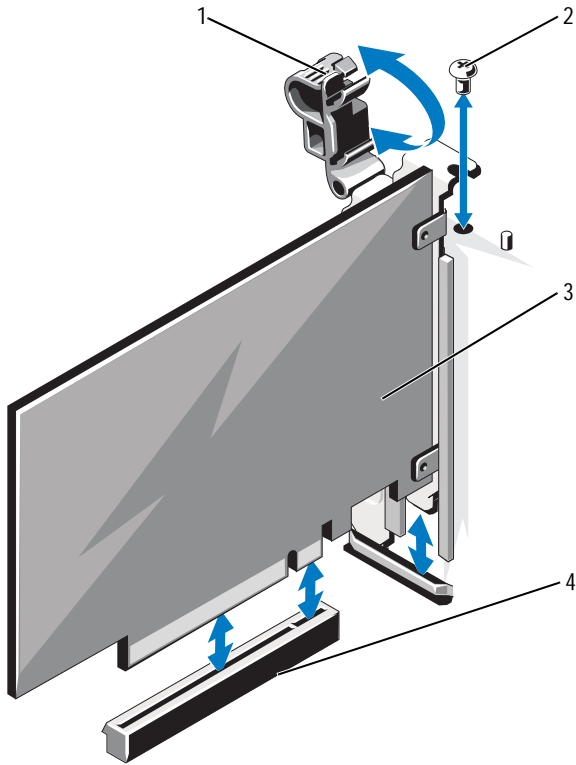

- 1 expansion-card latch
- 3 expansion card

- 2 screw
- 4 expansion-card connector

- 9 If applicable, connect any cables to the expansion card.
- 10 Close the system. See "Closing the System" on page 90.
- 11 Reconnect the system to its electrical outlet and turn the system on, including any attached peripherals.
- 12 Install any device drivers required for the card as described in the documentation for the card.

Removing an Expansion Card



CAUTION: Many repairs may only be done by a certified service technician. You should only perform troubleshooting and simple repairs as authorized in your product documentation, or as directed by the online or telephone service and support team. Damage due to servicing that is not authorized by Dell is not covered by your warranty. Read and follow the safety instructions that came with the product.

- 1 Turn off the system, including any attached peripherals, and disconnect the system from the electrical outlet.
- 2 Open the system. See "Opening the System" on page 89.
- 3 If applicable, disconnect all the cables from the card.
- 4 If applicable, remove the screw that secures the expansion card to the system.
- 5 To remove the expansion card, open the expansion-card latch. See Figure 3-19.
- 6 Grasp the expansion card by its edges, and carefully remove it from the expansion-card connector.
- 7 If you are removing the card permanently, install a metal filler bracket over the empty expansion slot opening and close the expansion-card latch.
 -  **NOTE:** You must install a filler bracket over an empty expansion slot to maintain Federal Communications Commission (FCC) certification of the system. The brackets also keep dust and dirt out of the system and aid in proper cooling and airflow inside the system.
- 8 Close the system. See "Closing the System" on page 90.
- 9 Reconnect the system to its electrical outlet and turn the system on, including any attached peripherals.

Installing an Expansion-Card Riser



CAUTION: Many repairs may only be done by a certified service technician. You should only perform troubleshooting and simple repairs as authorized in your product documentation, or as directed by the online or telephone service and support team. Damage due to servicing that is not authorized by Dell is not covered by your warranty. Read and follow the safety instructions that came with the product.

- 1 Unpack the expansion-card riser and prepare it for installation.
- 2 Turn off the system, including any attached peripherals, and disconnect the system from the electrical outlet.
- 3 Open the system. See "Opening the System" on page 89.
- 4 Pull the latch toward the front of the system and lift the expansion-card panel out of the system. See Figure 3-20.
- 5 To add expansion cards on the expansion-card riser, press the tabs toward each other and open the expansion-card latch. See Figure 3-21.
- 6 Holding the card by its edges, position the card so that the card-edge connector aligns with the connector on the expansion-card riser.
- 7 Insert the card-edge connector firmly into the expansion-card connector until the card is fully seated.
- 8 Close the expansion-card latch.
- 9 Align the expansion-card riser with the slots on the chassis. See Figure 3-22.
- 10 Lower the expansion-card riser until the riser is fully seated in the connector and the latch clicks into place. See Figure 3-22.
- 11 Close the system. See "Closing the System" on page 90.
- 12 Reconnect the system to its electrical outlet and turn the system on, including any attached peripherals.
- 13 Install any device drivers required for the card as described in the documentation for the card.

Figure 3-20. Removing and Installing the Panel

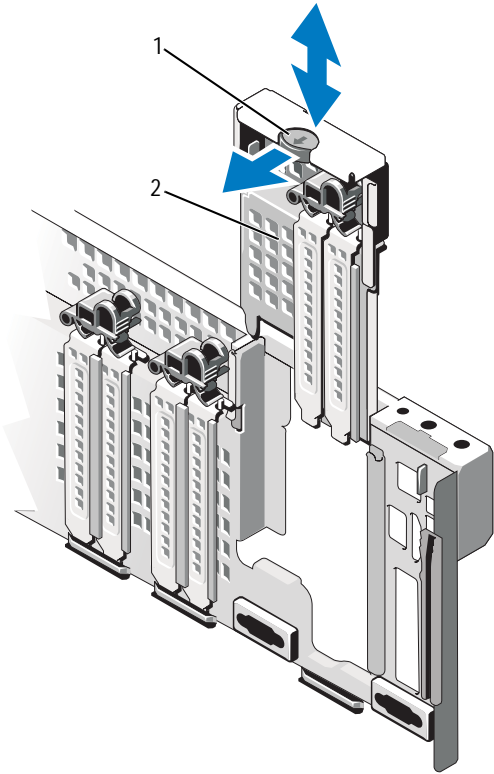

1 latch

2 panel

Figure 3-21. Removing and Installing an Expansion Card in an Expansion-Card Riser

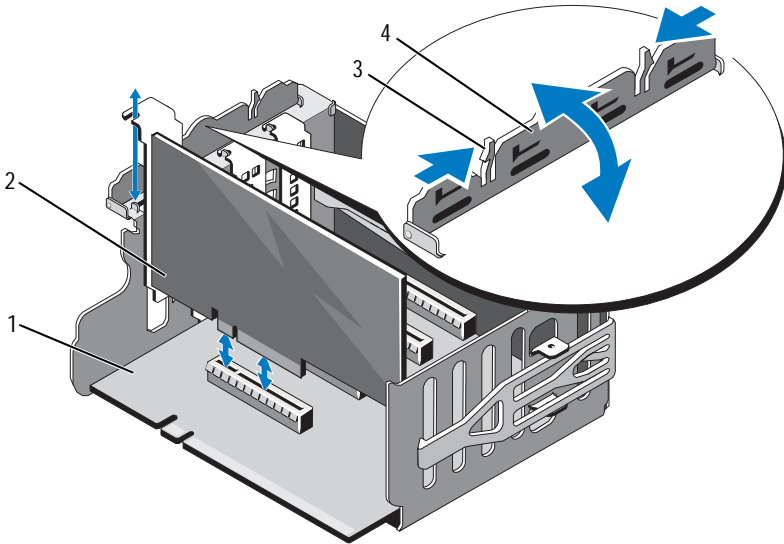

1 expansion-card riser

2 expansion card

3 tabs (2)

4 expansion-card latch

Figure 3-22. Removing and Installing an Expansion-Card Riser

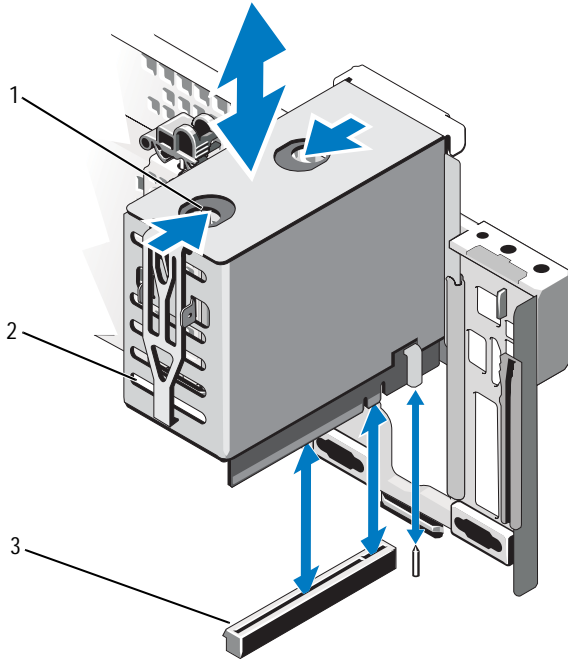

- 1 release tabs (2)
- 2 expansion-card riser
- 3 expansion-card riser connector

Removing an Expansion-Card Riser



CAUTION: Many repairs may only be done by a certified service technician. You should only perform troubleshooting and simple repairs as authorized in your product documentation, or as directed by the online or telephone service and support team. Damage due to servicing that is not authorized by Dell is not covered by your warranty. Read and follow the safety instructions that came with the product.

- 1 Turn off the system, including any attached peripherals, and disconnect the system from the electrical outlet.
- 2 Open the system. See "Opening the System" on page 89.
- 3 To remove the expansion-card riser, press the release tabs toward each other and lift the expansion-card riser out of the system. See Figure 3-22.
- 4 Press the tabs toward each other and open the expansion-card latch. See Figure 3-21.
- 5 Grasp the expansion-card by its edges, and carefully remove it from the expansion-card connector on the riser.
- 6 If you are removing the expansion-card riser permanently, install the panel in the system. See Figure 3-20.
 -  **NOTE:** You must install the panel over an empty expansion slot to maintain Federal Communications Commission (FCC) certification of the system. The brackets also keep dust and dirt out of the system and aid in proper cooling and airflow inside the system.
- 7 Close the system. See "Closing the System" on page 90.
- 8 Reconnect the system to its electrical outlet and turn the system on, including any attached peripherals.

I/O Card

Removing the I/O Card



CAUTION: Many repairs may only be done by a certified service technician. You should only perform troubleshooting and simple repairs as authorized in your product documentation, or as directed by the online or telephone service and support team. Damage due to servicing that is not authorized by Dell is not covered by your warranty. Read and follow the safety instructions that came with the product.

- 1 Turn off the system, including any attached peripherals, and disconnect the system from the electrical outlet.
- 2 If applicable, disconnect the external cables connected to the I/O card.
- 3 Open the system. See "Opening the System" on page 89.
- 4 Grasp the card by its edges and lift the card to remove it from the I/O card connector. See Figure 3-1 for the location of the I/O card in the system.
- 5 If applicable, remove the internal dual SD module. See "Removing the Internal Dual SD Module" on page 138.
- 6 If applicable, remove the iDRAC6 enterprise card. See "Removing an iDRAC6 Enterprise Card" on page 137.

Figure 3-23. Removing and Installing the I/O Card

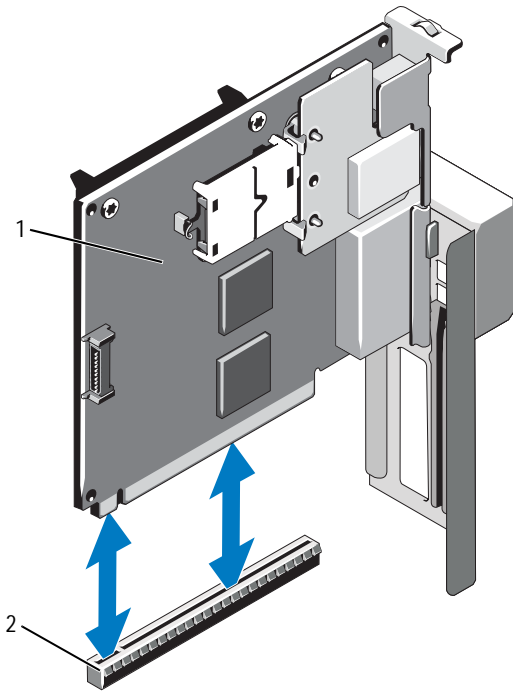

1 I/O card

2 I/O card connector

Installing the I/O Card

- 1 If applicable install the iDRAC6 Enterprise card. See "Installing an iDRAC6 Enterprise Card" on page 135.
- 2 If applicable, install the internal dual SD module. See "Installing the Internal Dual SD Module" on page 140.
- 3 Holding the card by its edges, position the card so that the card-edge connector aligns with the I/O card connector.
- 4 Insert the card-edge connector firmly into the I/O card connector until the card is fully seated.

- 5 Close the system. See "Closing the System" on page 90.
- 6 If applicable, reconnect the external cables to the I/O card.
- 7 Reconnect the system to its electrical outlet and turn the system on, including any attached peripherals.

iDRAC6 Enterprise Card (Optional)

Installing an iDRAC6 Enterprise Card

 **CAUTION:** Many repairs may only be done by a certified service technician. You should only perform troubleshooting and simple repairs as authorized in your product documentation, or as directed by the online or telephone service and support team. Damage due to servicing that is not authorized by Dell is not covered by your warranty. Read and follow the safety instructions that came with the product.

- 1 Turn off the system, including any attached peripherals, and disconnect the system from the electrical outlet.
- 2 Open the system. See "Opening the System" on page 89.
- 3 Remove the I/O card. See "Removing the I/O Card" on page 133.
- 4 Remove the plastic filler plug for the iDRAC6 Enterprise port from the I/O card.
- 5 Align the front edge of the card with the two front plastic retention standoffs next to the iDRAC6 connector on the system board, and lower the card into place. See Figure 3-24.

When the front of the card is fully seated, the plastic standoffs snap over the edge of the card.

Figure 3-24. Installing or Removing an iDRAC6 Enterprise Card (Optional)

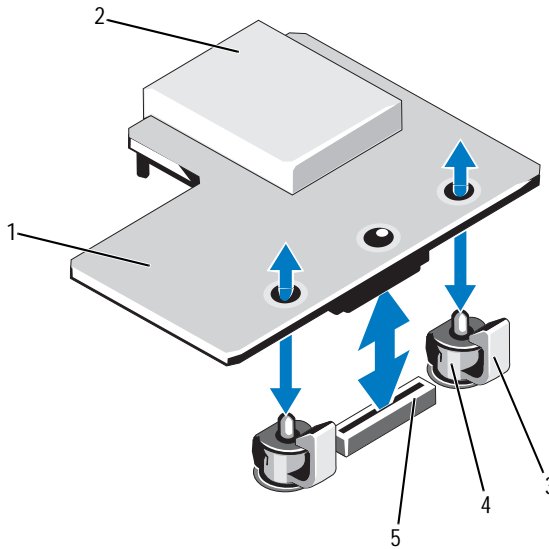

- | | | | |
|---|----------------------------------|---|------------------------------|
| 1 | iDRAC6 Enterprise card | 2 | VFlash media slot |
| 3 | retention standoff tabs (2) | 4 | retention standoff posts (2) |
| 5 | iDRAC6 Enterprise card connector | | |

- 6 Install the I/O card. See "Installing the I/O Card" on page 134.
- 7 Close the system. See "Closing the System" on page 90.
- 8 Reconnect the system and peripherals to their power sources, and turn them on.

Removing an iDRAC6 Enterprise Card



CAUTION: Many repairs may only be done by a certified service technician. You should only perform troubleshooting and simple repairs as authorized in your product documentation, or as directed by the online or telephone service and support team. Damage due to servicing that is not authorized by Dell is not covered by your warranty. Read and follow the safety instructions that came with the product.

- 1 Turn off the system, including any attached peripherals, and disconnect the system from the electrical outlet.
- 2 If applicable, disconnect the Ethernet cable from the iDRAC6 Enterprise Card connector on the system back panel. See Figure 1-3.
- 3 Open the system. See "Opening the System" on page 89.
- 4 Remove the I/O card. See "Removing the I/O Card" on page 133.
- 5 If applicable, remove the VFlash media card from the iDRAC6 Enterprise Card. See "Removing a VFlash Media Card" on page 138.
- 6 Pull back slightly on the two tabs at the front edge of the card and gently lift the front edge of the card off of the retention standoffs.
As the card releases from the standoffs, the connector under the card disengages from the system board connector.
- 7 Install the plastic filler plug over the port on the I/O card.
- 8 Install the I/O card. See "Installing the I/O Card" on page 134.
- 9 Close the system. See "Closing the System" on page 90.
- 10 Reconnect the system and peripherals to their power sources, and turn them on.

VFlash Media (Optional)

The VFlash media card is a Secure Digital (SD) card that plugs into the optional iDRAC6 Enterprise card at the back corner of the system.

Installing a VFlash Media Card

- 1 Locate the VFlash media slot at the back corner of the system.
- 2 With the label side facing up, insert the contact-pin end of the SD card into the card slot on the module.



NOTE: The slot is keyed to ensure correct insertion of the card.

- 3 Press inward on the card to lock it into the slot.

Removing a VFlash Media Card

To remove the VFlash media, push inward on the card to release it, and pull the card from the card slot.

Internal Dual SD Module (Optional)



NOTE: When the **Redundancy** option is set to **Mirror Mode** in the **Integrated Devices** screen of the system setup, the information is replicated from one SD card to another.

Removing the Internal Dual SD Module



CAUTION: Many repairs may only be done by a certified service technician. You should only perform troubleshooting and simple repairs as authorized in your product documentation, or as directed by the online or telephone service and support team. Damage due to servicing that is not authorized by Dell is not covered by your warranty. Read and follow the safety instructions that came with the product.

- 1 Turn off the system, including any attached peripherals, and disconnect the system from the electrical outlet.
- 2 Open the system. See "Opening the System" on page 89.
- 3 If applicable, remove the SD card(s). See "Removing an Internal SD Card" on page 141.
- 4 Remove the I/O card. See "Removing the I/O Card" on page 133.

- 5 Disconnect the SD module cable.
- 6 Pull back slightly on the tabs at the edge of the card and gently lift the edge of the card off of the retention standoffs.
- 7 Install the I/O card. See "Installing the I/O Card" on page 134.
- 8 Close the system. See "Closing the System" on page 90.
- 9 Reconnect the system and peripherals to their power sources, and turn them on.

Figure 3-25. Removing and Installing the Internal Dual SD Module

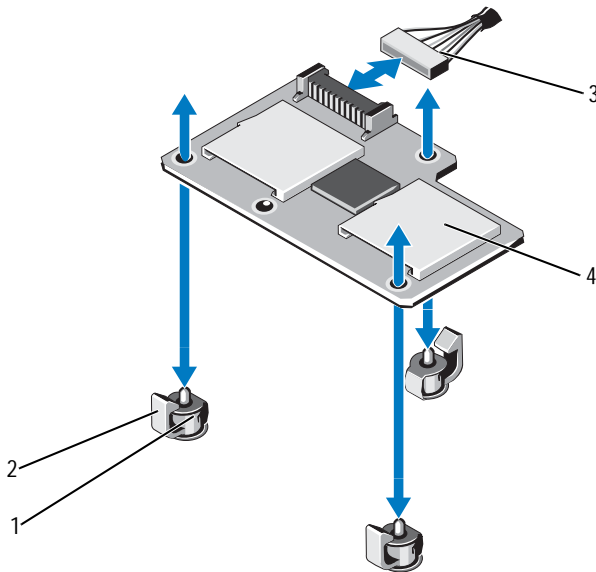

- | | | | |
|---|------------------------------|---|-----------------------------|
| 1 | retention standoff posts (3) | 2 | retention standoff tabs (3) |
| 3 | SD module cable | 4 | dual SD module |

Installing the Internal Dual SD Module



CAUTION: Many repairs may only be done by a certified service technician. You should only perform troubleshooting and simple repairs as authorized in your product documentation, or as directed by the online or telephone service and support team. Damage due to servicing that is not authorized by Dell is not covered by your warranty. Read and follow the safety instructions that came with the product.

- 1 Turn off the system, including any attached peripherals, and disconnect the system from the electrical outlet.
- 2 Open the system. See "Opening the System" on page 89.
- 3 Remove the I/O card. See "Removing the I/O Card" on page 133.
- 4 Align the card with the plastic retention standoffs on the I/O card, and lower the card into place. See Figure 3-24.

When the front of the card is fully seated, the plastic standoffs snap over the edge of the card.

- 5 Connect the SD module cable to the connector on the I/O card.
- 6 Install the I/O card. See "Installing the I/O Card" on page 134.
- 7 If applicable, install the SD card(s). See "Installing an Internal SD Card" on page 141.
- 8 Close the system. See "Closing the System" on page 90.
- 9 Reconnect the system and peripherals to their power sources, and turn them on.

Internal SD Card (Optional)

Installing an Internal SD Card

 **CAUTION:** Many repairs may only be done by a certified service technician. You should only perform troubleshooting and simple repairs as authorized in your product documentation, or as directed by the online or telephone service and support team. Damage due to servicing that is not authorized by Dell is not covered by your warranty. Read and follow the safety instructions that came with the product.

 **NOTE:** To use an SD card with your system, ensure that the internal SD card port is enabled in the System Setup program. See "Using the System Setup Program and UEFI Boot Manager" on page 63.

- 1 Turn off the system, including any attached peripherals, and disconnect the system from the electrical outlet.
- 2 Open the system. See "Opening the System" on page 89.
- 3 Locate the SD card connector on the internal dual SD module. With the label side facing up, insert the contact-pin end of the card into the slot.
 **NOTE:** The slot is keyed to ensure correct insertion of the card.
- 4 Press the card into the card slot to lock it into place.
- 5 Close the system. See "Closing the System" on page 90.
- 6 Reconnect the system and peripherals to their power sources, and turn them on.

Removing an Internal SD Card

 **CAUTION:** Many repairs may only be done by a certified service technician. You should only perform troubleshooting and simple repairs as authorized in your product documentation, or as directed by the online or telephone service and support team. Damage due to servicing that is not authorized by Dell is not covered by your warranty. Read and follow the safety instructions that came with the product.

- 1 Turn off the system, including any attached peripherals, and disconnect the system from the electrical outlet.
- 2 Open the system. See "Opening the System" on page 89.

- 3 Locate the SD card slot on the internal dual SD module and press inward on the card to release it from the slot and remove the card.
- 4 Close the system. See "Closing the System" on page 90.
- 5 Reconnect the system and peripherals to their power sources, and turn them on.

Integrated Storage Controller Card

Your system includes a dedicated expansion-card slot on the system board for an integrated controller card that provides the integrated storage subsystem for your system's internal hard drives. The controller supports SAS and SATA hard drives and also enables you to set up the hard drives in RAID configurations as supported by the version of the storage controller included with your system.

Removing the Integrated Storage Controller Card

 **CAUTION:** Many repairs may only be done by a certified service technician. You should only perform troubleshooting and simple repairs as authorized in your product documentation, or as directed by the online or telephone service and support team. Damage due to servicing that is not authorized by Dell is not covered by your warranty. Read and follow the safety instructions that came with the product.

- 1 Turn off the system, including any attached peripherals, and disconnect the system from the electrical outlet.
- 2 Open the system. See "Opening the System" on page 89.
- 3 Remove the I/O card. See "Removing the I/O Card" on page 133.
- 4 Disconnect the cables connected to the storage controller card. See Figure 3-1 for the location of the integrated storage controller card in the system.
- 5 Grasp the card by its edges and lift the card to remove it from the connector on the system board.
- 6 Install the I/O card. See "Installing the I/O Card" on page 134
- 7 Close the system. See "Closing the System" on page 90.
- 8 Reconnect the system to its electrical outlet and turn the system on, including any attached peripherals.

Figure 3-26. Installing the Integrated Storage Controller Card

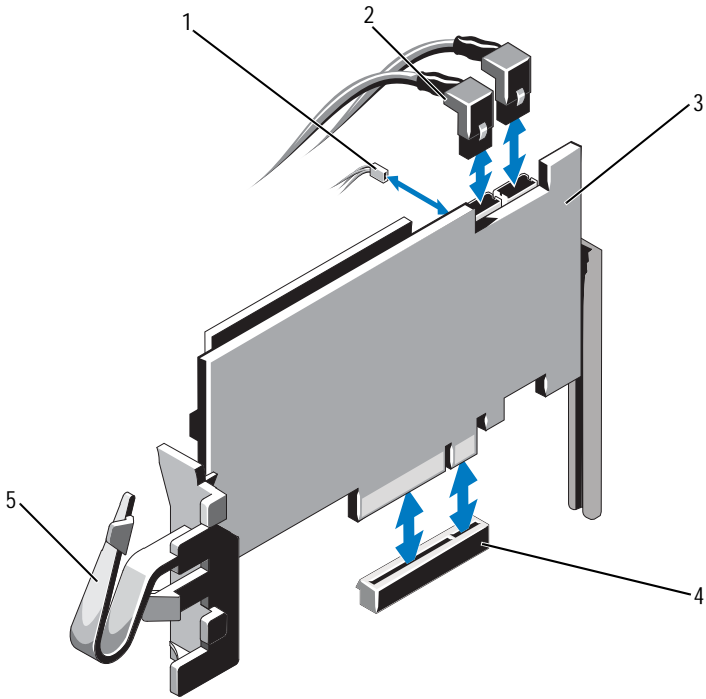

- | | | | |
|---|------------------------------------|---|--|
| 1 | battery cable | 2 | SAS data cables (2) |
| 3 | integrated storage controller card | 4 | integrated storage controller card connector |
| 5 | clip | | |

Installing the Integrated Storage Controller Card



CAUTION: Many repairs may only be done by a certified service technician. You should only perform troubleshooting and simple repairs as authorized in your product documentation, or as directed by the online or telephone service and support team. Damage due to servicing that is not authorized by Dell is not covered by your warranty. Read and follow the safety instructions that came with the product.

- 1 Turn off the system, including any attached peripherals, and disconnect the system from the electrical outlet.
- 2 Open the system. See "Opening the System" on page 89.
- 3 Remove the I/O card. See "Removing the I/O Card" on page 133.
- 4 Hold the card by its edges and insert the card-edge connector firmly into the connector until the card is fully seated and the plastic card guides fit over the edges of the card.
- 5 Connect the SAS data cable connector to the integrated storage controller card. See Figure 3-26.



NOTE: You must ensure that you connect the cable according to the connector labels on the cable. The cable does not function properly if reversed.

- 6 Route the SAS data cable through the clip on the card and through the channel on the inner side of the chassis.
- 7 Attach the connector labeled "SAS A" to connector SAS A on the backplane, and attach the connector labeled "SAS B" to connector SAS B on the backplane. See Figure 3-26.
- 8 Install the I/O card. See "Installing the I/O Card" on page 134.
- 9 Close the system. See "Closing the System" on page 90.
- 10 Reconnect the system to its electrical outlet and turn the system on, including any attached peripherals.

RAID Battery

The information in this section applies only to systems with the optional PERC controller card.

Removing a RAID Battery



CAUTION: Many repairs may only be done by a certified service technician. You should only perform troubleshooting and simple repairs as authorized in your product documentation, or as directed by the online or telephone service and support team. Damage due to servicing that is not authorized by Dell is not covered by your warranty. Read and follow the safety instructions that came with the product.

- 1 Turn off the system, including any attached peripherals, and disconnect the system from the electrical outlet.
- 2 Open the system. See "Opening the System" on page 89.
- 3 If applicable, remove the memory-riser blanks. See "Removing a Memory-Riser Blank" on page 99.
- 4 Remove the memory risers. See "Removing a Memory Riser" on page 100.
- 5 Remove the memory-riser guide. See "Removing the Memory-Riser Guide" on page 106.
- 6 Pull back gently on the right edge of the battery carrier and lift the RAID battery from the battery carrier. See Figure 3-27.
- 7 Disconnect the RAID battery cable from the RAID battery.

Figure 3-27. Removing or Installing the RAID Battery

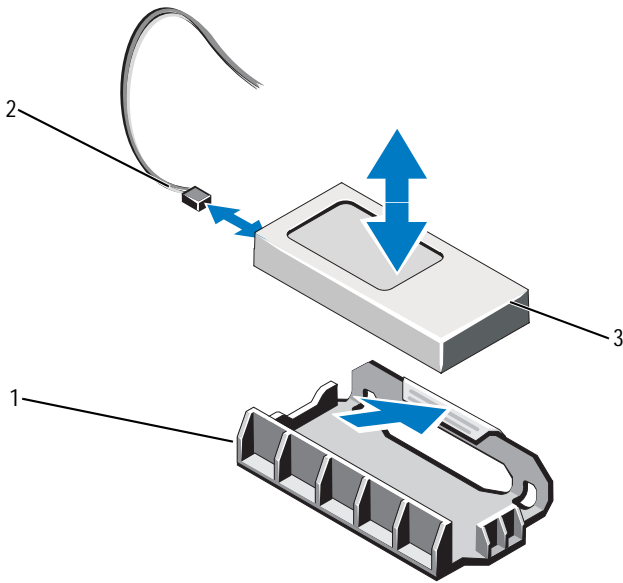

- 1 battery carrier
- 2 RAID battery cable
- 3 RAID battery

Installing the RAID Battery

CAUTION: Many repairs may only be done by a certified service technician. You should only perform troubleshooting and simple repairs as authorized in your product documentation, or as directed by the online or telephone service and support team. Damage due to servicing that is not authorized by Dell is not covered by your warranty. Read and follow the safety instructions that came with the product.

- 1 Connect the battery cable to the integrated storage controller card.
- 2 Route the battery cable/SAS A cable along the chassis wall.
- 3 Connect the battery cable to the RAID battery.

- 4 Insert the RAID battery into the battery carrier. See Figure 3-27.
 -  **NOTE:** While installing the RAID battery into the battery carrier, you must ensure that the RAID battery cable faces the chassis wall.
- 5 Install the memory-riser guide. See "Installing the Memory-Riser Guide" on page 107.
- 6 Install the memory risers. See "Installing a Memory Riser" on page 101.
- 7 If applicable, install the memory-riser blanks. See "Installing a Memory-Riser Blank" on page 100.
- 8 Close the system. See "Closing the System" on page 90.
- 9 Reconnect the system to its electrical outlet and turn the system on, including any attached peripherals.

Processors

Removing a Processor

 **CAUTION:** Many repairs may only be done by a certified service technician. You should only perform troubleshooting and simple repairs as authorized in your product documentation, or as directed by the online or telephone service and support team. Damage due to servicing that is not authorized by Dell is not covered by your warranty. Read and follow the safety instructions that came with the product.

- 1 Prior to upgrading your system, download the latest system BIOS version from **support.dell.com** and follow the instructions included in the compressed download file to install the update on your system.
- 2 Turn off the system, including any attached peripherals, and disconnect the system from the electrical outlet. When disconnected from AC power, press and hold the power button for three seconds to fully drain the system of stored power prior to removing the cover.
 -  **NOTE:** It is recommended that you always use a static mat and static strap while working on components in the interior of the system.
- 3 Open the system. See "Opening the System" on page 89.
- 4 If applicable, remove the memory-riser blanks. See "Removing a Memory-Riser Blank" on page 99.
- 5 Remove the memory risers. See "Removing a Memory Riser" on page 100.

- 6 Remove the cooling fan assembly. See "Removing the Cooling Fan Assembly" on page 117.



WARNING: The heat sink and processor are hot to touch for some time after the system has been powered down. Allow the heat sink and processor to cool before handling them.



CAUTION: Never remove the heat sink from a processor unless you intend to remove the processor. The heat sink is necessary to maintain proper thermal conditions.

- 7 Release one of the heat-sink release levers. See Figure 3-28.
- 8 Wait 30 seconds for the heat sink to loosen from the processor.
- 9 Release the other heat-sink release lever.
- 10 Gently lift the heat sink off of the processor and set the heat sink aside upside down (thermal grease side facing up).

Figure 3-28. Installing and Removing the Heat Sink

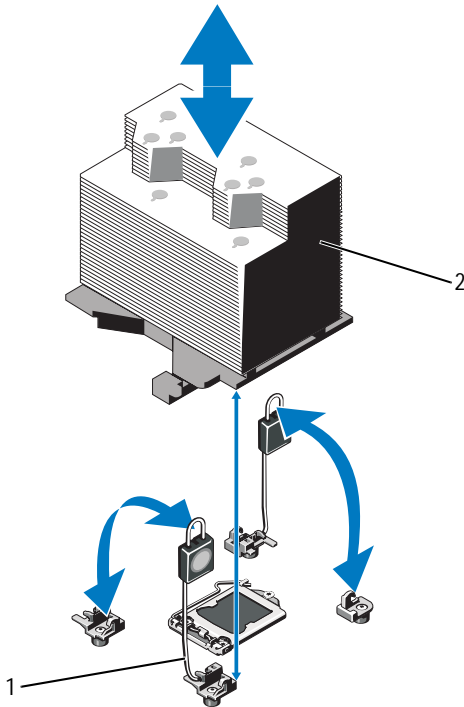

1 release levers (2)

2 heat sink

CAUTION: The processor is held in its socket under strong pressure. Be aware that the release lever can spring up suddenly if not firmly grasped.

- 11 Position your thumb firmly over the processor socket-release lever and release the lever from the locked position by pushing down and pulling out from under the tab. Rotate the lever 90 degrees upward until the processor is released from the socket. See Figure 3-28.
- 12 Use the tab on the processor shield to rotate shield upward and out of the way. See Figure 3-28.

CAUTION: Be careful not to bend any of the pins on the ZIF socket when removing the processor. Bending the pins can permanently damage the system board.

- 13 Carefully lift the processor out of the socket and leave the release lever up so that the socket is ready for the new processor.

After removing the processor, place it in an antistatic container for reuse, return, or temporary storage. Do not touch the bottom of the processor. Touch only the side edges of the processor.

Figure 3-29. Removing and Installing a Processor

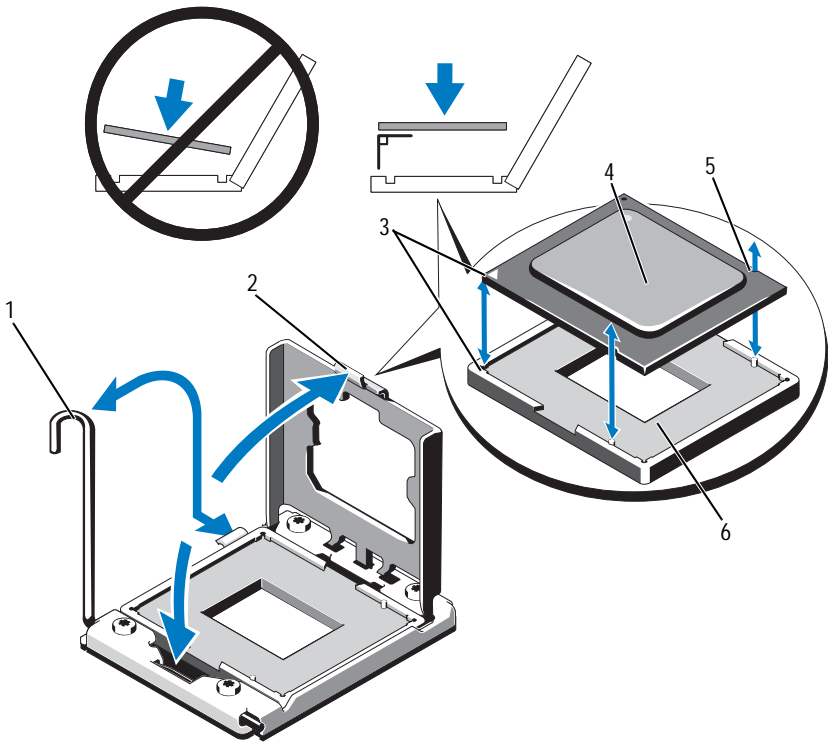

- | | | | |
|---|------------------------|---|------------------|
| 1 | socket-release lever | 2 | processor shield |
| 3 | pin 1 indicators (2) | 4 | processor |
| 5 | notch in processor (2) | 6 | ZIF socket |

Installing a Processor

⚠ CAUTION: Many repairs may only be done by a certified service technician. You should only perform troubleshooting and simple repairs as authorized in your product documentation, or as directed by the online or telephone service and support team. Damage due to servicing that is not authorized by Dell is not covered by your warranty. Read and follow the safety instructions that came with the product.

📎 NOTE: In a dual-processor configuration, CPU 1 and CPU 2 sockets must be used.

- 1 If you are adding a processor for the first time, remove the socket cover. See Figure 3-30.

Figure 3-30. Removing the Processor Socket Cover

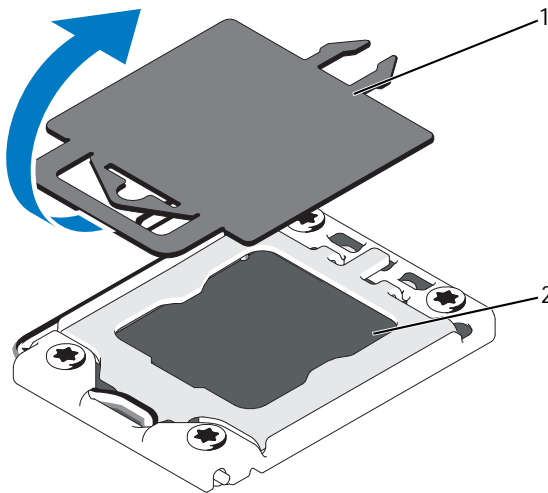

- | | | | |
|---|-----------------|---|------------------|
| 1 | processor cover | 2 | processor socket |
|---|-----------------|---|------------------|

- 2 Remove the processor from the packing material by the processor's edges only. Do not touch the bottom of the processor. Handle the processor carefully with your fingers on the side edges. Place your hand beneath the processor when you are moving it to the system.
- 3 Locate the pin 1 indicator on the system board socket.
- 4 Locate the pin 1 indicator on the top of the processor. The pin 1 indicator is shown as a triangle on the top of the processor. See Figure 3-29.

 **CAUTION: Positioning the processor incorrectly can permanently damage the system board or the processor. Be careful not to bend the pins in the socket.**

- 5 Place the processor over the socket with each pin 1 aligned and level. See Figure 3-29.
- 6 Align the notches in the processor with the socket keys on the ZIF socket. See Figure 3-29.
- 7 Install the processor in the socket. Keep the processor level (see Figure 3-29) and insert it straight down into the socket. Allow the processor to float on the pins, allowing the processor shield to hold it in place.
- 8 Verify that the processor is properly aligned and seated.
- 9 Close the processor shield. See Figure 3-29.
- 10 Rotate the socket-release lever down until it snaps into place. See Figure 3-29.
- 11 Using a clean lint-free cloth, remove the thermal grease from the heat sink.

 **CAUTION: Applying too much thermal grease can result in excess grease coming in contact with and contaminating the processor socket.**

- 12 Open the grease applicator included with your processor kit and apply all of the thermal grease in the applicator to the center of the topside of the new processor.
- 13 Place the heat sink on the processor. See Figure 3-28.
- 14 Close the heat-sink release levers. See Figure 3-28.
- 15 Install the cooling fan assembly. See "Installing the Cooling Fan Assembly" on page 119.
- 16 Install the memory risers. See "Installing a Memory Riser" on page 101.

- 17 If applicable, install the memory-riser blanks. See "Installing a Memory-Riser Blank" on page 100.
- 18 Close the system. See "Closing the System" on page 90.
- 19 Reconnect your system and peripherals to their electrical outlets, and turn on the system.

Power Supplies

Your system supports the following power supply modules:

- 1100 W (high output power supply)
- 750 W (energy smart power supply)

When a 10 Gb I/O card is installed, the system must have at least two power supplies connected to an A/C power supply. The system requires two power supplies to provide standby power to the system. With a 1 GbE I/O card, only one PSU is required to provide standby power to the system. Table 3-4 and Table 3-5 lists the power supply redundancy modes for a 10 Gb I/O card and a 1 GbE I/O card.

Table 3-4. Power Supply Redundancy Modes With a 10 Gb I/O Card

Number of Power Supplies	Redundancy Mode	System Configuration
1	1+ 0*	Non-redundant configuration with inactive SFP+ ports
2	2+ 0	Non-redundant configuration
3	2+ 0	Non-redundant configuration
4	2+ 2	Redundant configuration

* indicates that the system operates with a limited load.

Table 3-5. Power Supply Redundancy Modes With a 1 GbE I/O Card

Number of Power Supplies	Redundancy Mode	System Configuration
1	1+ 0*	Non-redundant configuration
2	1+ 1*	Redundant configuration
2	2+ 0	Non-redundant configuration
3	2+ 1	Redundant configuration
4	2+ 2	Redundant configuration

*indicates that the system operates with a limited load.

Removing a Power Supply

 **CAUTION:** The system requires one power supply to operate the system normally. On power-redundant systems, remove and replace only one power supply at a time in a system that is powered on.

- 1 Disconnect the power cable from the power source.
- 2 Disconnect the power cable from the power supply and remove the Velcro straps that bundle and secure the system cables.



NOTE: You may have to unlatch and lift the optional cable management arm if it interferes with power-supply removal. For information about the cable management arm, see the system's rack documentation.

- 3 Pull the power supply straight out to release it from the power distribution board and clear the chassis.

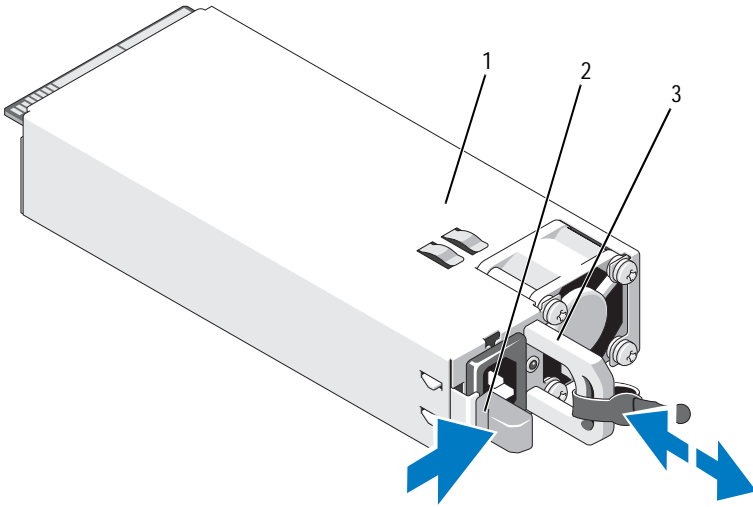

If you are permanently removing the power supply, you must install a power supply blank to ensure proper system cooling. See "Installing the Power Supply Blank" on page 156.

Figure 3-31. Removing and Installing a Power Supply



- 1 power supply
- 2 locking tab
- 3 cable retention bracket

Installing a Power Supply

- 1 Verify that power supplies are the same type and have the same maximum output power.
 -  **NOTE:** The maximum output power (shown in watts) is listed on the power supply label.
- 2 If applicable, remove the power supply blank. See "Removing the Power Supply Blank" on page 156.
- 3 Slide the new power supply into the chassis until the power supply is fully seated and the release latch snaps into place. See Figure 3-31.
 -  **NOTE:** If you unlatched the cable management arm in step of the previous procedure, relatch it. For information about the cable management arm, see the system's rack documentation.
- 4 Connect the power cable to the power supply and plug the cable into a power outlet.

 **CAUTION:** When connecting the power cable, secure the cable with the Velcro strap.

 **NOTE:** When installing, hot-swapping, or hot-adding a new power supply in a system, allow several seconds for the system to recognize the power supply and determine its status. The power-supply status indicator turns green to signify that the power supply is functioning properly.

Removing the Power Supply Blank

If you are installing a power supply, remove the power supply blank by pulling outward on the blank.

 **CAUTION:** To ensure proper system cooling, the power supply blank must be installed in each power supply bay that does not have a power supply. Remove the power supply blank only if you are installing an additional power supply.

Installing the Power Supply Blank

 **NOTE:** Install the power supply blank only in power supply bays 2, 3, or 4.

To install the power supply blank, align the blank with the power supply bay and insert the blank into the chassis until it clicks into place.

System Battery

Replacing the System Battery

 **WARNING:** There is a danger of a new battery exploding if it is incorrectly installed. Replace the battery only with the same or equivalent type recommended by the manufacturer. See your safety information for additional information.

 **CAUTION:** Many repairs may only be done by a certified service technician. You should only perform troubleshooting and simple repairs as authorized in your product documentation, or as directed by the online or telephone service and support team. Damage due to servicing that is not authorized by Dell is not covered by your warranty. Read and follow the safety instructions that came with the product.

- 1 Turn off the system, including any attached peripherals, and disconnect the system from the electrical outlet.
- 2 Open the system. See "Opening the System" on page 89.

Figure 3-32. Replacing the System Battery

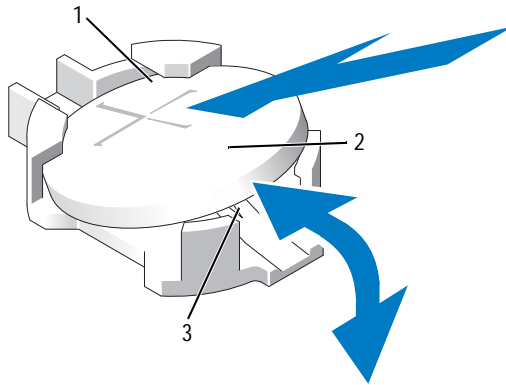

- 1 positive side of battery connector
- 2 system battery
- 3 negative side of battery connector

3 Locate the battery socket. See "System Board Connectors" on page 198.

△ CAUTION: To avoid damage to the battery connector, you must firmly support the connector while installing or removing a battery.

- 4 To remove the battery, support the battery connector by pressing down firmly on the positive side of the connector.
- 5 Press the battery toward the positive side of the connector and lift it up out of the securing tabs at the negative side of the connector.
- 6 To install a new system battery, support the battery connector by pressing down firmly on the positive side of the connector.
- 7 Hold the battery with the "+" facing up and slide it under the securing tabs at the positive side of the connector.
- 8 Press the battery straight down into the connector until it snaps into place.
- 9 Close the system. See "Closing the System" on page 90.
- 10 Reconnect the system to the electrical outlet and turn the system on, including any attached peripherals.

- 11 Enter the System Setup program to confirm that the battery is operating properly. See "Using the System Setup Program and UEFI Boot Manager" on page 63.
- 12 Enter the correct time and date in the System Setup program's **Time** and **Date** fields.
- 13 Exit the System Setup program.

SAS Backplane



NOTE: Depending on your configuration, your system supports either an x16 SAS backplane or an x4 SAS backplane. The illustration in this section shows the removal and installation of an x16 SAS backplane.

Removing the SAS Backplane



CAUTION: Many repairs may only be done by a certified service technician. You should only perform troubleshooting and simple repairs as authorized in your product documentation, or as directed by the online or telephone service and support team. Damage due to servicing that is not authorized by Dell is not covered by your warranty. Read and follow the safety instructions that came with the product.

- 1 If installed, remove the front bezel. See "Removing the Front Bezel" on page 87.
- 2 Turn off the system and attached peripherals, and disconnect the system from the electrical outlet.
- 3 Open the system. See "Opening the System" on page 89.



CAUTION: To prevent damage to the drives and backplane, you must remove the hard drives from the system before removing the backplane.



CAUTION: You must note the number of each hard drive and temporarily label them before removal so that you can replace them in the same locations.

- 4 Remove all hard drives. See "Removing a Hard Drive" on page 109.
- 5 If applicable, remove the memory-riser blanks. See "Removing a Memory-Riser Blank" on page 99.
- 6 Remove the memory risers. See "Removing a Memory Riser" on page 100.
- 7 Disconnect the SAS data cable(s) and power cable from the backplane.
- 8 If applicable, disconnect the power/data cable from the optical drive.

- 9 Pull the blue release pin(s) and slide the backplane upwards.
- 10 Pull the backplane away from the front of the system until the securing slots are free from the tabs on the chassis.

Figure 3-33. Removing and Installing a SAS Backplane

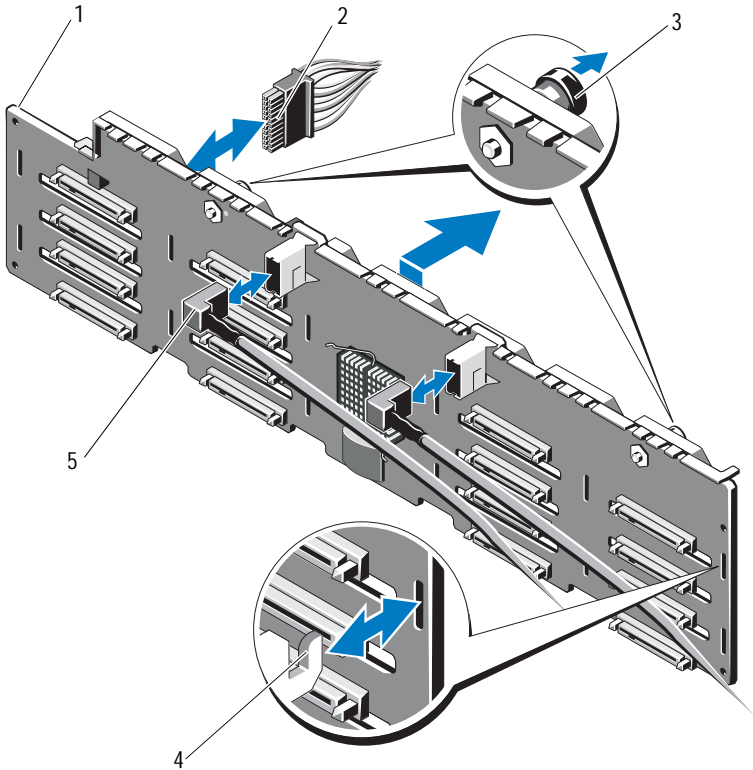

- 1 SAS backplane
- 3 release pins (2)
- 5 SAS cables (2)

- 2 power cable
- 4 chassis tabs

Installing the SAS Backplane

- 1 Align the slots on the SAS backplane with the tabs on the chassis.
- 2 Slide down the SAS backplane until the release pin snaps into place.
- 3 Connect the SAS data cable(s) and power cable to the backplane.
- 4 If applicable, connect the optical drive power/data cable.
- 5 Install the memory risers. See "Installing a Memory Riser" on page 101.
- 6 If applicable, install the memory-riser blanks. See "Installing a Memory-Riser Blank" on page 100.
- 7 Install the hard drives in their original locations. See "Installing a Hard Drive" on page 110.
- 8 Close the system. See "Closing the System" on page 90.
- 9 Reconnect the system to its electrical outlet and turn the system on, including any attached peripherals.
- 10 If applicable, install the front bezel. See "Installing the Front Bezel" on page 87.

Power Distribution Board

Removing the Power Distribution Board



CAUTION: Many repairs may only be done by a certified service technician. You should only perform troubleshooting and simple repairs as authorized in your product documentation, or as directed by the online or telephone service and support team. Damage due to servicing that is not authorized by Dell is not covered by your warranty. Read and follow the safety instructions that came with the product.

- 1 Turn off the system and attached peripherals, and disconnect the system from the electrical outlet.
- 2 Remove the power supplies from the system. See "Removing a Power Supply" on page 154.
- 3 Open the system. See "Opening the System" on page 89.
- 4 If applicable, remove the memory-riser blanks. See "Removing a Memory-Riser Blank" on page 99.
- 5 Remove the memory risers. See "Removing a Memory Riser" on page 100.

- 6 Remove the cooling fan assembly. See "Removing the Cooling Fan Assembly" on page 117.
- 7 Slide the board upwards and pull the board toward the front of the system until the tabs on the board are free from the securing slots on the chassis. See Figure 3-34.

Figure 3-34. Power Distribution Board

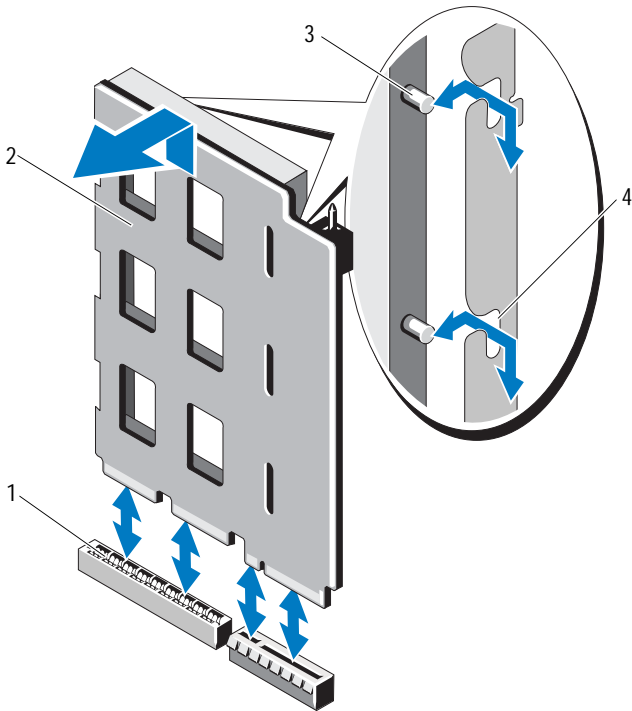

- | | | | |
|---|------------------------------------|---|--------------------------|
| 1 | power distribution board connector | 2 | power distribution board |
| 3 | tabs (2) | 4 | securing slots (2) |

Replacing the Power Distribution Board



CAUTION: Many repairs may only be done by a certified service technician. You should only perform troubleshooting and simple repairs as authorized in your product documentation, or as directed by the online or telephone service and support team. Damage due to servicing that is not authorized by Dell is not covered by your warranty. Read and follow the safety instructions that came with the product.

- 1 Unpack the new power distribution board assembly.
- 2 Align the tabs on the board with the slots on the chassis.
- 3 Press the board into the connector until it is fully seated.
- 4 Install the cooling fan assembly. See "Installing the Cooling Fan Assembly" on page 119.
- 5 Install the memory risers. See "Installing a Memory Riser" on page 101.
- 6 If applicable, install the memory-riser blanks. See "Installing a Memory-Riser Blank" on page 100.
- 7 Close the system. See "Closing the System" on page 90.
- 8 Install the power supplies in the system. See "Installing a Power Supply" on page 155.
- 9 Reconnect the system to its electrical outlet and turn the system on, including any attached peripherals.

Control Panel Assembly

Removing the Control Panel Display Module



CAUTION: Many repairs may only be done by a certified service technician. You should only perform troubleshooting and simple repairs as authorized in your product documentation, or as directed by the online or telephone service and support team. Damage due to servicing that is not authorized by Dell is not covered by your warranty. Read and follow the safety instructions that came with the product.

- 1 If installed, remove the front bezel. See "Removing the Front Bezel" on page 87.
- 2 Turn off the system and attached peripherals, and disconnect the system from the electrical outlet.

- 3 Open the system. See "Opening the System" on page 89.
- 4 Disconnect the display module cable from the control panel board.
- 5 Using a knife or a small flat-blade screwdriver, insert the blade beneath the front panel of the display and slide the blade across the bottom to lift the panel outward. See Figure 3-35.
- 6 Bend the panel upward to access to the mounting screws.
- 7 Using a T10 Torx driver, remove the two screws that secure the display module to the system chassis.
- 8 Remove the display module from the chassis cutout.

Installing the Control Panel Display Module



CAUTION: Many repairs may only be done by a certified service technician. You should only perform troubleshooting and simple repairs as authorized in your product documentation, or as directed by the online or telephone service and support team. Damage due to servicing that is not authorized by Dell is not covered by your warranty. Read and follow the safety instructions that came with the product.

- 1 Insert the display module into the chassis cutout and secure the module with the two Torx screws. See Figure 3-35.
- 2 Attach the replacement panel to the front of the display module.
- 3 Connect the display module cable to the control panel board.
- 4 Close the system. See "Closing the System" on page 90.
- 5 Reconnect the system to its electrical outlet and turn the system on, including any attached peripherals.
- 6 If applicable, install the front bezel. See "Installing the Front Bezel" on page 87.

Figure 3-35. Removing or Installing the Control Panel Assembly

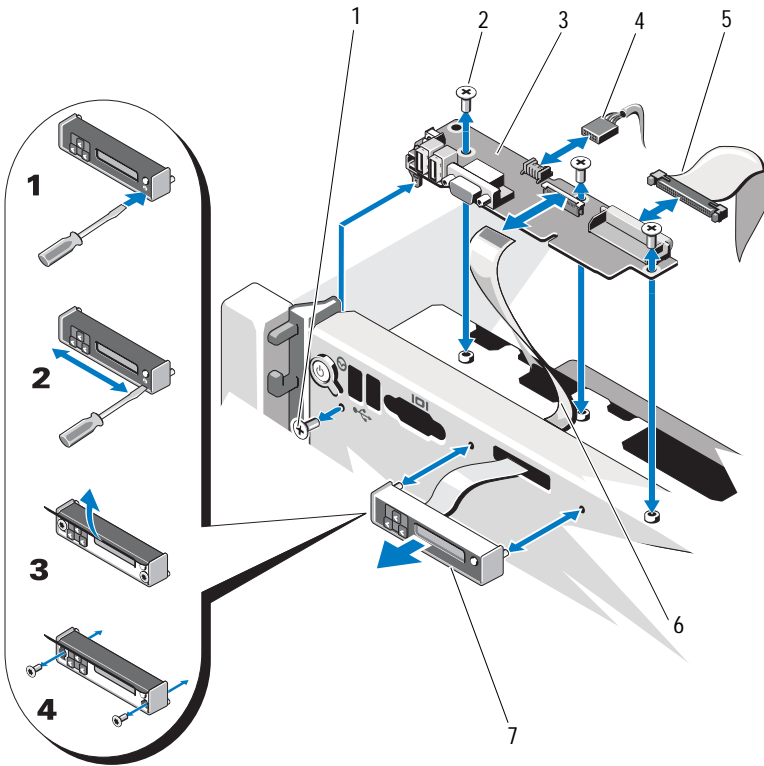

- | | | | |
|---|---------------------|---|----------------------|
| 1 | T8 Torx screw | 2 | T10 Torx screws (3) |
| 3 | control panel board | 4 | USB cable |
| 5 | control panel cable | 6 | display module cable |
| 7 | display module | | |

Removing the Control Panel Board



CAUTION: Many repairs may only be done by a certified service technician. You should only perform troubleshooting and simple repairs as authorized in your product documentation, or as directed by the online or telephone service and support team. Damage due to servicing that is not authorized by Dell is not covered by your warranty. Read and follow the safety instructions that came with the product.

- 1 Turn off the system and attached peripherals, and disconnect the system from the electrical outlet.
- 2 Open the system. See "Opening the System" on page 89.
- 3 If applicable, remove the memory-riser blanks. See "Removing a Memory-Riser Blank" on page 99.
- 4 Remove the memory risers. See "Removing a Memory Riser" on page 100.
- 5 Remove the memory-riser guide. See "Removing the Memory-Riser Guide" on page 106.
- 6 Disconnect the cables connected to the control panel board.



NOTE: Note the routing of the cables on the side on the system as you remove them from the control panel board. You must route these cables properly when you replace them to prevent them from being pinched or crimped.

- 7 Using a T10 Torx driver, remove the three screws that secure the control panel board to the chassis. See Figure 3-35.
- 8 Using a T8 Torx driver, remove the screw that secures the control panel board on the front of the system. See Figure 3-35.
- 9 Slide the control panel assembly toward the back of the system and take it out.

Installing the Control Panel Board





CAUTION: Many repairs may only be done by a certified service technician. You should only perform troubleshooting and simple repairs as authorized in your product documentation, or as directed by the online or telephone service and support team. Damage due to servicing that is not authorized by Dell is not covered by your warranty. Read and follow the safety instructions that came with the product.

- 1 Align the screw holes on the control panel board with the holes on the chassis.
- 2 Using a T10 Torx driver, replace the screws that secure the control panel board to the chassis. See Figure 3-35.
- 3 Using a T8 Torx driver, replace the screw that secures the control panel board on the front of the system. See Figure 3-35.
- 4 Connect all the cables to the control panel board.
- 5 Install the memory-riser guide. See "Installing the Memory-Riser Guide" on page 107.
- 6 Install the memory risers. See "Installing a Memory Riser" on page 101.
- 7 If applicable, install the memory-riser blanks. See "Installing a Memory-Riser Blank" on page 100.
- 8 Close the system. See "Closing the System" on page 90.
- 9 Reconnect the system to its electrical outlet and turn the system on, including any attached peripherals.

System Board

Removing the System Board

-  **CAUTION:** Many repairs may only be done by a certified service technician. You should only perform troubleshooting and simple repairs as authorized in your product documentation, or as directed by the online or telephone service and support team. Damage due to servicing that is not authorized by Dell is not covered by your warranty. Read and follow the safety instructions that came with the product.
-  **CAUTION:** If you are using the Trusted Program Module (TPM) with an encryption key, you may be prompted to create a recovery key during program or system setup. Be sure to create and safely store this recovery key. If you replace this system board, you must supply the recovery key when you restart your system or program before you can access the encrypted data on your hard drives.
- 1 Turn off the system and attached peripherals, and disconnect the system from the electrical outlet.
 - 2 Open the system. See "Opening the System" on page 89.
 - 3 If applicable, remove the memory-riser blanks. See "Removing a Memory-Riser Blank" on page 99.
 - 4 Remove the memory risers. See "Removing a Memory Riser" on page 100.
 - 5 Remove the cooling fan assembly. See "Removing the Cooling Fan Assembly" on page 117.
 - 6 Remove the power supply(s). See "Removing a Power Supply" on page 154.
 - 7 Remove all expansion cards, the I/O card, and the integrated storage controller card. See "Removing an Expansion Card" on page 127, "Removing the I/O Card" on page 133, and "Removing the Integrated Storage Controller Card" on page 142.
 - 8 If applicable, remove the USB key from the system board. See "Internal USB Memory Key" on page 119.
 - 9 If applicable, remove the NIC hardware key from the system board. See "Integrated NIC Hardware Key" on page 122.
 - 10 Remove the processor(s). See "Removing a Processor" on page 147.
 - 11 Remove the power distribution board. See "Removing the Power Distribution Board" on page 160.



- 12 Disconnect all cables from the system board.
 - 13 Loosen the thumbscrew that secures the system board to the chassis.
 - 14 Pull the blue release pin and slide the system board toward the front of the system.
-  **CAUTION:** Do not lift the system board assembly by grasping a memory module, processor, or other components.
- 15 Grasp the system board using the handle and the card guides. Angle the system board toward the front of the system and lift the board out of the chassis.

Figure 3-36. Removing and Installing the System Board

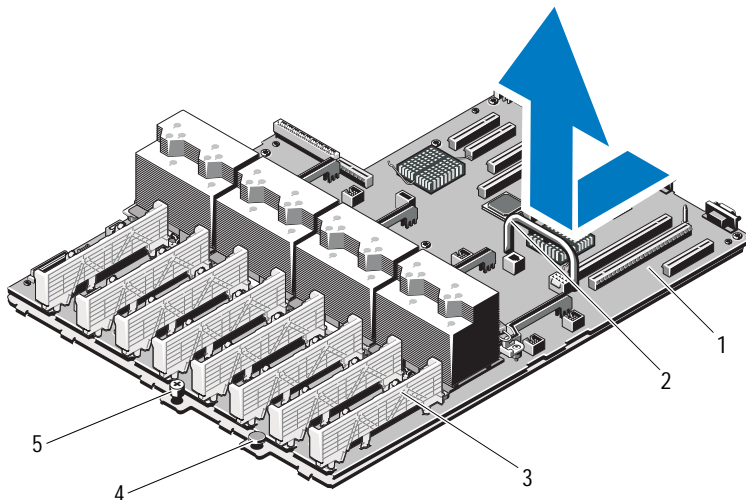

- | | | | |
|---|--------------|---|-------------|
| 1 | system board | 2 | handle |
| 3 | card guide | 4 | release pin |
| 5 | thumbscrew | | |

Installing the System Board

 **CAUTION:** Many repairs may only be done by a certified service technician. You should only perform troubleshooting and simple repairs as authorized in your product documentation, or as directed by the online or telephone service and support team. Damage due to servicing that is not authorized by Dell is not covered by your warranty. Read and follow the safety instructions that came with the product.

- 1 Unpack the new system board.
- 2 Remove the labels from the processor shield and affix them to the system identification panel on the front of the system. See Figure 3-36.
- 3 Using the handle and the card guide, lower the system board into the chassis.

 **CAUTION:** Do not lift the system board assembly by grasping a memory module, processor, or other components.

- 4 Slightly lift up the front of the system board and maneuver the system board to the bottom of the chassis until it lays completely flat.
- 5 Push the system board toward the back of the chassis until the board clicks into place.
- 6 Tighten the thumbscrew that secures the system board to the chassis.
- 7 Connect all the cables to the system board.
- 8 Install the power distribution board. See "Replacing the Power Distribution Board" on page 162.
- 9 Transfer the processors to the new system board. See "Removing a Processor" on page 147 and "Installing a Processor" on page 151.
- 10 If applicable, install the NIC hardware key on the system board. See "Integrated NIC Hardware Key" on page 122.
- 11 If applicable, install the internal USB key on the system board. See "Internal USB Memory Key" on page 119.
- 12 Install all expansion cards, the I/O card, and the integrated storage controller card. See "Installing an Expansion Card" on page 125, "Installing the I/O Card" on page 134, and "Installing the Integrated Storage Controller Card" on page 144.
- 13 Install the cooling fan assembly. See "Installing the Cooling Fan Assembly" on page 119.

- 14 Install the memory risers in the same locations on the new board. See "Installing a Memory Riser" on page 101.
- 15 If applicable, install the memory-riser blanks. See "Installing a Memory-Riser Blank" on page 100.
- 16 Close the system. See "Closing the System" on page 90.
- 17 Reconnect the system to its electrical outlet and turn the system on, including any attached peripherals.

Troubleshooting Your System

Safety First—For You and Your System

△ CAUTION: Many repairs may only be done by a certified service technician. You should only perform troubleshooting and simple repairs as authorized in your product documentation, or as directed by the online or telephone service and support team. Damage due to servicing that is not authorized by Dell is not covered by your warranty. Read and follow the safety instructions that came with the product.

Troubleshooting System Startup Failure

If your system halts during startup prior to video imaging or LCD messaging, especially after installing an operating system or reconfiguring your system's hardware, check for the following conditions:

- If you boot the system to the BIOS boot mode after installing an operating system from the UEFI Boot Manager, the system will hang. The reverse is also true. You must boot to the same boot mode in which you installed the operating system. See "Using the System Setup Program and UEFI Boot Manager" on page 63.
- Invalid memory configurations could cause the system to halt at startup without any video output. See "System Memory" on page 91.

For all other startup issues, note the LCD panel messages and any system messages that appear onscreen. See "LCD Status Messages" on page 23 and "System Messages" on page 41 for more information.

Troubleshooting External Connections

Ensure that all external cables are securely attached to the external connectors on your system before troubleshooting any external devices. See Figure 1-1 and Figure 1-3 for the front- and back-panel connectors on your system.

Troubleshooting the Video Subsystem

- 1 Check the system and power connections to the monitor.
- 2 Check the video interface cabling from the system to the monitor.
- 3 If two monitors are attached to the system, disconnect one monitor. The system supports only one monitor attached to either the front or rear video connector.
- 4 Run the appropriate online diagnostic test. See "Using Online Diagnostics" on page 193.

If the tests run successfully, the problem is not related to video hardware.

If the tests fail, see "Getting Help" on page 203.

Troubleshooting a USB Device

- 1 Use the following steps to troubleshoot a USB keyboard and/or mouse. For other USB devices, go to step 2.
 - a Disconnect the keyboard and mouse cables from the system briefly and reconnect them.
 - b Connect the keyboard/mouse to the USB port(s) on the opposite side of the system.

If the problem is resolved, restart the system, enter the System Setup program, and check if the nonfunctioning USB ports are enabled.
 - c Replace the keyboard/mouse with another working keyboard/mouse.

If the problem is resolved, replace the faulty keyboard/mouse.

If the problem is not resolved, proceed to the next step to begin troubleshooting the other USB devices attached to the system.
- 2 Power down all attached USB devices and disconnect them from the system.
- 3 Restart the system and, if your keyboard is functioning, enter the system setup program. Verify that all USB ports are enabled. See "Integrated Devices Screen" on page 70.

If your keyboard is not functioning, you can also use remote access. If the system is not accessible, see "Disabling a Forgotten Password" on page 201

for instructions on setting the NVRAM_CLR jumper inside your system and restoring the BIOS to the default settings.

- 4 Reconnect and power on each USB device one at a time.
- 5 If a device causes the same problem, power down the device, replace the USB cable, and power up the device.

If the problem persists, replace the device.

If all troubleshooting fails, see "Getting Help" on page 203.

Troubleshooting a Serial I/O Device

- 1 Turn off the system and any peripheral devices connected to the serial port.
- 2 Swap the serial interface cable with a working cable, and turn on the system and the serial device.

If the problem is resolved, replace the interface cable.

- 3 Turn off the system and the serial device, and swap the device with a comparable device.
- 4 Turn on the system and the serial device.

If the problem is resolved, replace the serial device.

If the problem persists, see "Getting Help" on page 203.

Troubleshooting a NIC

- 1 Run the appropriate online diagnostic test. See "Using Online Diagnostics" on page 193.
- 2 Restart the system and check for any system messages pertaining to the NIC controller.
- 3 Check the appropriate indicator on the NIC connector. See "NIC Indicator Codes" on page 21.

- If the link indicator does not light, check all cable connections.
- If the activity indicator does not light, the network driver files might be damaged or missing.

Remove and reinstall the drivers if applicable. See the NIC's documentation.

- Change the autonegotiation setting, if possible.
- Use another connector on the switch or hub.

If you are using a NIC card instead of an integrated NIC, see the documentation for the NIC card.

- 4 Ensure that the appropriate drivers are installed and the protocols are bound. See the NIC's documentation.
- 5 Enter the System Setup program and confirm that the NIC ports are enabled. See "Integrated Devices Screen" on page 70.
- 6 Ensure that the NICs, hubs, and switches on the network are all set to the same data transmission speed and duplex. See the documentation for each network device.
- 7 Ensure that all network cables are of the proper type and do not exceed the maximum length.

If all troubleshooting fails, see "Getting Help" on page 203.

Troubleshooting a Wet System



CAUTION: Many repairs may only be done by a certified service technician. You should only perform troubleshooting and simple repairs as authorized in your product documentation, or as directed by the online or telephone service and support team. Damage due to servicing that is not authorized by Dell is not covered by your warranty. Read and follow the safety instructions that came with the product.

- 1 Turn off the system and attached peripherals, and disconnect the system from the electrical outlet.
- 2 Open the system. See "Opening the System" on page 89.
- 3 Disassemble components from the system. See "Installing System Components" on page 85.
 - Hard drives
 - Optical drive
 - Memory risers
 - Cooling fan assembly
 - SD cards

- USB memory key
 - NIC hardware key
 - Expansion cards and both expansion-card risers
 - I/O card
 - Integrated storage controller
 - Power supplies
 - Processors and heat sinks
- 4 Let the system dry thoroughly for at least 24 hours.
 - 5 Reinstall the components you removed in step 3.
 - 6 Close the system. See "Closing the System" on page 90.
 - 7 Reconnect the system to the electrical outlet, and turn on the system and attached peripherals.
If the system does not start properly, see "Getting Help" on page 203.
 - 8 Run the appropriate online diagnostic test. See "Using Online Diagnostics" on page 193.
If the tests fail, see "Getting Help" on page 203.

Troubleshooting a Damaged System



CAUTION: Many repairs may only be done by a certified service technician. You should only perform troubleshooting and simple repairs as authorized in your product documentation, or as directed by the online or telephone service and support team. Damage due to servicing that is not authorized by Dell is not covered by your warranty. Read and follow the safety instructions that came with the product.

- 1 Turn off the system and attached peripherals, and disconnect the system from the electrical outlet.
- 2 Open the system. See "Opening the System" on page 89.
- 3 Ensure that the following components are properly installed:
 - Hard drives
 - Memory risers
 - Cooling fan assembly

- SD cards
 - USB memory key
 - NIC hardware key
 - Expansion cards and both expansion-card risers
 - I/O card
 - Integrated storage controller
 - Power supplies
 - Processors and heat sinks
- 4 Ensure that all cables are properly connected.
 - 5 Close the system. See "Closing the System" on page 90.
 - 6 Run the system board tests in the system diagnostics. See "Running the Embedded System Diagnostics" on page 194.
- If the tests fail, see "Getting Help" on page 203.

Troubleshooting the System Battery



NOTE: If the system is turned off for long periods of time (for weeks or months), the NVRAM may lose its system configuration information. This situation is caused by a defective battery.

- 1 Re-enter the time and date through the System Setup program. See "Using the System Setup Program and UEFI Boot Manager" on page 63.
- 2 Turn off the system and disconnect it from the electrical outlet for at least one hour.
- 3 Reconnect the system to the electrical outlet and turn on the system.
- 4 Enter the System Setup program.

If the date and time are not correct in the System Setup program, replace the battery. See "Replacing the System Battery" on page 156.



NOTE: Some software may cause the system time to speed up or slow down. If the system seems to operate normally except for the time kept in the System Setup program, the problem may be caused by software rather than by a defective battery.

If the problem is not resolved by replacing the battery, see "Getting Help" on page 203.

Troubleshooting Power Supplies

 **CAUTION:** At least one power supply must be installed for the system to operate. Operating the system with only one power supply installed for extended periods of time can cause the system to overheat.

- 1 Identify the faulty power supply by the power supply's fault indicator. See "Power Indicator Codes" on page 22.

 **CAUTION:** If troubleshooting a power supply mismatch error, replace only the power supply with the flashing indicator. Swapping the opposite power supply to make a matched pair can result in an error condition and unexpected system shutdown. To change from a High Output configuration to an Energy Smart configuration or vice versa, you must power down the system.

- 2 Reseat the power supply by removing and reinstalling it. See "Removing a Power Supply" on page 154 and "Installing a Power Supply" on page 155.

 **NOTE:** After installing a power supply, allow several seconds for the system to recognize the power supply and to determine if it is working properly. The power indicator turns green to signify that the power supply is functioning properly.

If the problem persists, replace the faulty power supply.

- 3 If the problem persists, see "Getting Help" on page 203.

Troubleshooting System Cooling Problems

- △ CAUTION:** Many repairs may only be done by a certified service technician. You should only perform troubleshooting and simple repairs as authorized in your product documentation, or as directed by the online or telephone service and support team. Damage due to servicing that is not authorized by Dell is not covered by your warranty. Read and follow the safety instructions that came with the product.

Ensure that none of the following conditions exist:

- System cover, drive blank, memory-module blank, power-supply blank, or back filler bracket is removed.
- Ambient temperature is too high. See your *Getting Started Guide* for your system's operating temperature requirements.
- External airflow is obstructed.
- Cables inside the system obstruct airflow.
- An individual cooling fan is removed or has failed. See "Troubleshooting a Fan" on page 180.
- The expansion card installation guidelines have not been followed. See "Expansion Card Installation Guidelines" on page 123.

Troubleshooting a Fan

- △ CAUTION:** Many repairs may only be done by a certified service technician. You should only perform troubleshooting and simple repairs as authorized in your product documentation, or as directed by the online or telephone service and support team. Damage due to servicing that is not authorized by Dell is not covered by your warranty. Read and follow the safety instructions that came with the product.

- 1 Open the system. See "Opening the System" on page 89.

- △ CAUTION:** The cooling fans are hot-swappable. To maintain proper cooling while the system is on, only replace one fan at a time.

- 2 Locate the faulty fan indicated by the LCD panel or the diagnostic software.

- 3 Remove and reseal the fan. See "Removing a Cooling Fan" on page 115 and "Installing a Cooling Fan" on page 116.



NOTE: Wait at least 30 seconds for the system to recognize the fan and determine whether it is working properly.

- 4 If the problem is not resolved, install a new fan. See "Removing a Cooling Fan" on page 115 and "Installing a Cooling Fan" on page 116.

If the replacement fan is working properly, close the system. See "Closing the System" on page 90.

If the replacement fan does not operate, see "Getting Help" on page 203.

Troubleshooting System Memory



CAUTION: Many repairs may only be done by a certified service technician. You should only perform troubleshooting and simple repairs as authorized in your product documentation, or as directed by the online or telephone service and support team. Damage due to servicing that is not authorized by Dell is not covered by your warranty. Read and follow the safety instructions that came with the product.



NOTE: Invalid memory configurations can cause your system to halt at startup without video output. See "General Memory Module Installation Guidelines" on page 92 and verify that your memory configuration complies with all applicable guidelines.

- 1 If the system is operational, run the appropriate online diagnostic test. See "Using Online Diagnostics" on page 193.

If diagnostics indicates a fault, follow the corrective actions provided by the diagnostic program.

- 2 If the system is not operational, turn off the system and attached peripherals, and unplug the system from the power source. Wait at least 10 seconds and then reconnect the system to power.
- 3 Turn on the system and attached peripherals and note the messages on the screen.

Go to step 14 if an error message appears indicating a fault with a specific memory module.

- 4 Enter the System Setup program and check the system memory setting. See "Memory Settings Screen" on page 67. Make any changes to the memory settings, if needed.
If the memory settings match the installed memory but a problem is still indicated, go to step 14.
- 5 Turn off the system and attached peripherals, and disconnect the system from the electrical outlet.
- 6 Open the system. See "Opening the System" on page 89.
- 7 Remove the memory risers. See "Removing a Memory Riser" on page 100.
- 8 Check the memory channels and ensure that they are populated correctly. See "General Memory Module Installation Guidelines" on page 92.
- 9 Reseat the memory modules in their sockets. See "Installing Memory Modules" on page 102.
- 10 Install the memory risers. See "Installing a Memory Riser" on page 101.
- 11 Close the system. See "Closing the System" on page 60.
- 12 Reconnect the system to its electrical outlet, and turn on the system and attached peripherals.
- 13 Enter the System Setup program and check the system memory setting. See "Memory Settings Screen" on page 67.
If the problem is not resolved, proceed with the next step.
- 14 If a diagnostic test or error message indicates a specific memory module as faulty, swap or replace the module.
- 15 Open the system. See "Opening the System" on page 89.
- 16 Remove the memory risers. See "Removing a Memory Riser" on page 100.
- 17 To troubleshoot an unspecified faulty memory module, replace the memory module in the first DIMM socket with a module of the same type and capacity. See "Installing Memory Modules" on page 102.
- 18 Install the memory risers. See "Installing a Memory Riser" on page 101.
- 19 Close the system. See "Closing the System" on page 90.
- 20 Reconnect the system to its electrical outlet, and turn on the system and attached peripherals.

- 21 As the system boots, observe any error message that appears and the diagnostic indicators on the front of the system.
- 22 If the memory problem is still indicated, repeat step 14 through step 19 for each memory module installed.

If the problem persists after all memory modules have been checked, see "Getting Help" on page 203.

Troubleshooting an Internal USB Key



CAUTION: Many repairs may only be done by a certified service technician. You should only perform troubleshooting and simple repairs as authorized in your product documentation, or as directed by the online or telephone service and support team. Damage due to servicing that is not authorized by Dell is not covered by your warranty. Read and follow the safety instructions that came with the product.

- 1 Enter the System Setup program and ensure that the internal USB key port is enabled. See "Integrated Devices Screen" on page 70.
- 2 Turn off the system and attached peripherals, and disconnect the system from the electrical outlet.
- 3 Open the system. See "Opening the System" on page 89.
- 4 Locate the USB key and reseal it. See "Internal USB Memory Key" on page 119.
- 5 Close the system. See "Closing the System" on page 90.
- 6 Turn on the system and attached peripherals and check if the USB key is functioning.
- 7 If the problem is not resolved, repeat step 2 and step 3.
- 8 Insert a different USB key that you know works properly.
- 9 Close the system. See "Closing the System" on page 90.
- 10 Turn on the system and attached peripherals and check if the USB key is functioning.

If the problem is not resolved, see "Getting Help" on page 203.

Troubleshooting an Internal SD Card

 **CAUTION:** Many repairs may only be done by a certified service technician. You should only perform troubleshooting and simple repairs as authorized in your product documentation, or as directed by the online or telephone service and support team. Damage due to servicing that is not authorized by Dell is not covered by your warranty. Read and follow the safety instructions that came with the product.

- 1 Enter the System Setup program and ensure that the internal SD card port is enabled. See "Integrated Devices Screen" on page 70.
- 2 Turn off the system, including any attached peripherals, and disconnect the system from the electrical outlet.
- 3 Open the system. See "Opening the System" on page 89.
- 4 Reseat the SD module cable. See "Installing the Internal Dual SD Module" on page 140.

 **CAUTION:** If the Redundancy option is set to Mirror Mode in the Integrated Devices screen of the system setup, you must follow the instructions in step 5 to step 9 to avoid loss of data. If the Redundancy option is set to Disabled, proceed to step 10.



NOTE: When an SD card failure occurs, the internal dual SD module controller notifies the system. On the next reboot, the system prompts you with a message indicating the failure.

- 5 If SD card 1 has failed, remove the card from the SD1 slot. See "Removing an Internal SD Card" on page 141. If SD card 2 has failed, install a new SD card and proceed to step 8.
- 6 Insert the card present in the SD2 slot into the SD1 slot. See "Removing an Internal SD Card" on page 141 and "Installing an Internal SD Card" on page 141.
- 7 Insert the new SD card into the SD2 slot.
- 8 Close the system. See "Closing the System" on page 90.
- 9 Turn on the system and attached peripherals and check if the SD card is functioning.
If the problem is not resolved, see "Getting Help" on page 203.
- 10 Insert a different SD card that you know works properly.

- 11 Close the system. See "Closing the System" on page 90.
- 12 Turn on the system and attached peripherals and check if the SD card is functioning.

If the problem is not resolved, see "Getting Help" on page 203.

Troubleshooting an Optical Drive



CAUTION: Many repairs may only be done by a certified service technician. You should only perform troubleshooting and simple repairs as authorized in your product documentation, or as directed by the online or telephone service and support team. Damage due to servicing that is not authorized by Dell is not covered by your warranty. Read and follow the safety instructions that came with the product.

- 1 If applicable, remove the bezel. See "Removing the Front Bezel" on page 87.
- 2 Try using a different CD or DVD.
- 3 Enter the System Setup program and ensure that the integrated SATA controller and the drive's SATA port are enabled. See "Using the System Setup Program and UEFI Boot Manager" on page 63.
- 4 Run the appropriate online diagnostic test. See "Using Online Diagnostics" on page 193.
- 5 Turn off the system and attached peripherals, and disconnect the system from the electrical outlet.
- 6 Open the system. See "Opening the System" on page 89.
- 7 Ensure that the interface cable is securely connected to the optical drive and to the system board. See "Optical Drive" on page 112.
- 8 Ensure that a power cable is properly connected to the drive.
- 9 Close the system. See "Closing the System" on page 90.
- 10 Reconnect the system to the electrical outlet, and turn on the system and attached peripherals.

If the problem is not resolved, see "Getting Help" on page 203.

Troubleshooting a Tape Backup Unit

- 1 Ensure that the tape drive is turned on.
- 2 Try using a different tape cartridge.
- 3 Ensure that the device drivers for the tape drive are installed and are configured correctly. See your tape drive documentation for more information about device drivers.
- 4 Ensure that the tape drive's interface cable is fully connected to the external port on the controller card.
- 5 For SCSI tape drives, verify that the tape drive is configured for a unique SCSI ID number and that the tape drive is terminated or not terminated, based on the interface cable used to connect the drive. See the documentation for the tape drive for instructions on selecting the SCSI ID number and enabling or disabling termination.
- 6 Run the appropriate online diagnostics tests. See "Using Online Diagnostics" on page 193.
If you cannot resolve the problem, see "Getting Help" on page 203.
- 7 Reinstall the tape-backup software as instructed in the tape-backup software documentation. See your tape documentation for information about reinstalling the software and troubleshooting the tape drive.

Troubleshooting a Hard Drive

 **CAUTION:** Many repairs may only be done by a certified service technician. You should only perform troubleshooting and simple repairs as authorized in your product documentation, or as directed by the online or telephone service and support team. Damage due to servicing that is not authorized by Dell is not covered by your warranty. Read and follow the safety instructions that came with the product.

 **CAUTION:** This troubleshooting procedure can destroy data stored on the hard drive. Before you proceed, back up all files on the hard drive.

- 1 Run the appropriate online diagnostics test. See "Using Online Diagnostics" on page 193.

Depending on the results of the diagnostics test, proceed as needed through the following steps.

- 2 If applicable, remove the bezel. See "Removing the Front Bezel" on page 87.
- 3 If your system has a RAID controller and your hard drives are configured in a RAID array, perform the following steps.
 - a Restart the system and enter the host adapter configuration utility program by pressing <Ctrl><R> for a PERC controller or <Ctrl><C> for a SAS controller.
See the documentation supplied with the host adapter for information about the configuration utility.
 - b Ensure that the hard drive(s) have been configured correctly for the RAID array.
 - c Take the hard drive offline and reseal the drive. See "Removing a Hard Drive" on page 109.
 - d Exit the configuration utility and allow the system to boot to the operating system.
- 4 Ensure that the required device drivers for your controller card are installed and are configured correctly. See the operating system documentation for more information.
- 5 Restart the system, enter the System Setup program, and verify that the controller is enabled and the drives appear in the System Setup program. See "Using the System Setup Program and UEFI Boot Manager" on page 63.
If the problem persists, see "Troubleshooting a Storage Controller" on page 187.

Troubleshooting a Storage Controller



NOTE: When troubleshooting a SAS or PERC controller, also see the documentation for your operating system and the controller.

- 1 Run the appropriate online diagnostic test. See "Using Online Diagnostics" on page 193.
- 2 Enter the System Setup program and ensure that the SAS or PERC controller is enabled. See "Using the System Setup Program and UEFI Boot Manager" on page 63.

3 Restart the system and press the applicable key sequence to enter the configuration utility program:

- < Ctrl> < C> for a SAS controller
- < Ctrl> < R> for PERC controller

See the controller's documentation for information about configuration settings.

4 Check the configuration settings, make any necessary corrections, and restart the system.



CAUTION: Many repairs may only be done by a certified service technician. You should only perform troubleshooting and simple repairs as authorized in your product documentation, or as directed by the online or telephone service and support team. Damage due to servicing that is not authorized by Dell is not covered by your warranty. Read and follow the safety instructions that came with the product.

5 Turn off the system and attached peripherals, and disconnect the system from its electrical outlet.

6 Open the system. See "Opening the System" on page 89.

7 Ensure that the controller card is firmly seated into the system board connector. See "Integrated Storage Controller Card" on page 142.

8 If you have a PERC controller with a battery-backed cache, ensure that the RAID battery is properly connected and, if applicable, the memory module on the PERC card is properly seated.

9 Verify that the cable connections between the SAS backplane and the integrated storage controller are correct. See "Installing the Integrated Storage Controller Card" on page 144 and Figure 6-2.

Ensure that the cables are firmly connected to the storage controller and the SAS backplane board.

10 Close the system. See "Closing the System" on page 90.

11 Reconnect the system to its electrical outlet, and turn on the system and attached peripherals.

If the problem persists, see "Getting Help" on page 203.

Troubleshooting Expansion Cards



CAUTION: Many repairs may only be done by a certified service technician. You should only perform troubleshooting and simple repairs as authorized in your product documentation, or as directed by the online or telephone service and support team. Damage due to servicing that is not authorized by Dell is not covered by your warranty. Read and follow the safety instructions that came with the product.



NOTE: When troubleshooting an expansion card, see the documentation for your operating system and the expansion card.

- 1 Run the appropriate online diagnostic test. See "Using Online Diagnostics" on page 193.
- 2 Turn off the system and attached peripherals, and disconnect the system from the electrical outlet.
- 3 Open the system. See "Opening the System" on page 89.
- 4 Verify that the installed expansion cards are compliant with the expansion card installation guidelines. See "Expansion Card Installation Guidelines" on page 123.
- 5 Ensure that each expansion card is firmly seated in its connector. See "Installing an Expansion Card" on page 125.
- 6 Close the system. See "Closing the System" on page 90.
- 7 Reconnect the system to the electrical outlet, and turn on the system and attached peripherals.
- 8 If the problem is not resolved, turn off the system and attached peripherals, and disconnect the system from the electrical outlet.
- 9 Open the system. See "Opening the System" on page 89.
- 10 Remove all expansion cards installed in the system. See "Removing an Expansion Card" on page 127.
- 11 Close the system. See "Closing the System" on page 90.
- 12 Reconnect the system to the electrical outlet, and turn on the system and attached peripherals.
- 13 Run the appropriate online diagnostic test.
If the tests fail, see "Getting Help" on page 203.

- 14 For each expansion card you removed in step 10, perform the following steps:
 - a Turn off the system and attached peripherals, and disconnect the system from the electrical outlet.
 - b Open the system. See "Opening the System" on page 89.
 - c Reinstall one of the expansion cards.
 - d Close the system. See "Closing the System" on page 90.
 - e Run the appropriate diagnostic test.
If the tests fail, see "Getting Help" on page 203.

Troubleshooting the Processors



CAUTION: Many repairs may only be done by a certified service technician. You should only perform troubleshooting and simple repairs as authorized in your product documentation, or as directed by the online or telephone service and support team. Damage due to servicing that is not authorized by Dell is not covered by your warranty. Read and follow the safety instructions that came with the product.

- 1 Run the appropriate online diagnostics test. See "Using Online Diagnostics" on page 193.
- 2 Turn off the system and attached peripherals, and disconnect the system from the electrical outlet.
- 3 Open the system. See "Opening the System" on page 89.
- 4 Remove the memory risers. See "Removing a Memory Riser" on page 100.
- 5 Remove the cooling fan assembly. See "Removing the Cooling Fan Assembly" on page 117.
- 6 Ensure that each processor and heat sink are properly installed. See "Removing a Processor" on page 147.
- 7 Install the cooling fan assembly. See "Installing the Cooling Fan Assembly" on page 119.
- 8 Install the memory risers. See "Installing a Memory Riser" on page 101.
- 9 Close the system. See "Closing the System" on page 90.
- 10 Reconnect the system to the electrical outlet, and turn on the system and attached peripherals.

- 11 Run the appropriate online diagnostic test.
If the problem still persists, see step 12.
- 12 Open the system. See "Opening the System" on page 89.
- 13 Remove the memory risers. See "Removing a Memory Riser" on page 100.
- 14 Remove the cooling fan assembly. See "Removing the Cooling Fan Assembly" on page 117.
- 15 If your system has four processors, remove all processors except for processor 1 and processor 2. See "Installing a Processor" on page 151.
- 16 Install the cooling fan assembly. See "Installing the Cooling Fan Assembly" on page 119.
- 17 Install the memory risers. See "Installing a Memory Riser" on page 101.
- 18 Close the system. See "Closing the System" on page 90.
- 19 Reconnect the system to the electrical outlet, and turn on the system and attached peripherals.
- 20 Run the appropriate online diagnostic test.
If the test fails, the processor is faulty. See "Getting Help" on page 203.

If the test passes, replace processor 1 and 2 with processor 3 and processor 4. Run the appropriate online diagnostic test. If the test fails, the processor is faulty. See "Getting Help" on page 203.

Running the System Diagnostics

If you experience a problem with your system, run the diagnostics before calling for technical assistance. The purpose of the diagnostics is to test your system's hardware without requiring additional equipment or risking data loss. If you are unable to fix the problem yourself, service and support personnel can use diagnostics test results to help you solve the problem.

Using Online Diagnostics

To assess a system problem, first use the online diagnostics. Online Diagnostics is a suite of diagnostic programs, or test modules, that include diagnostic tests on chassis and storage components such as hard drives, physical memory, communications, NICs, CMOS, and more. If you are unable to identify the problem using the online diagnostics, then use the embedded system diagnostics.

The files required to run the online diagnostics for systems running supported Microsoft® Windows® and Linux operating systems are available at support.dell.com and on the CDs that came with your system. For information about using diagnostics, see the *Dell Online Diagnostics User's Guide*.

Embedded System Diagnostics Features

The system diagnostics provides a series of menus and options for particular device groups or devices. The system diagnostics menus and options allow you to:

- Run tests individually or collectively
- Control the sequence of tests
- Repeat tests
- Display, print, or save test results
- Temporarily suspend testing if an error is detected or terminate testing when a user-defined error limit is reached
- View help messages that briefly describe each test and its parameters

- View status messages that inform you if tests are completed successfully
- View error messages that inform you of problems encountered during testing

When to Use the Embedded System Diagnostics

If a major component or device in the system does not operate properly, component failure may be indicated. As long as the processor and the system's input/output devices are functioning, you can use the embedded system diagnostics to help identify the problem.

Running the Embedded System Diagnostics

The embedded system diagnostics program is run from the Lifecycle Controller screen.

 **CAUTION:** Use the embedded system diagnostics to test only your system. Using this program with other systems may cause invalid results or error messages.

- 1 As the system boots, press < F10 > .
- 2 Click **Diagnostics** in the left pane and click **Launch Diagnostics** in the right pane.

The **Diagnostics** menu allows you to run all or specific diagnostics tests or to exit.

System Diagnostics Testing Options

Click the testing option in the **Main Menu** window.

Testing Option	Function
Express Test	Performs a quick check of the system. This option runs device tests that do not require user interaction.
Extended Test	Performs a more thorough check of the system. This test can take an hour or longer.
Custom Test	Tests a particular device.
Information	Displays test results.

Using the Custom Test Options

When you select **Custom Test** in the **Main Menu** window, the **Customize** window allows you to select the device(s) to be tested, select specific options for testing, and view the test results.

Selecting Devices for Testing

The left side of the **Customize** window lists devices that can be tested. Click the (+) next to a device or module to view its components. Click (+) on any component to view the tests that are available. Clicking a device, rather than its components, selects all of the components of the device for testing.



NOTE: After you select all the devices and components that you want to test, highlight **All Devices** and then click **Run Tests**.

Selecting Diagnostics Options

From the **Diagnostics Options** area, select the test(s) you want to run on a device.

- **Non-Interactive Tests Only** — Runs only tests that require no user intervention.
- **Quick Tests Only** — Runs only the quick tests on the device.
- **Show Ending Timestamp** — Time stamps the test log.
- **Test Iterations** — Selects the number of times the test is run.
- **Log output file pathname** — Enables you to specify the diskette drive or USB memory key where the test log file is saved. You cannot save the file to a hard drive.

Viewing Information and Results

The following tabs in the **Customize** window provide information about the test and the test results.

- **Results** — Displays the test that ran and the result.
- **Errors** — Displays any errors that occurred during the test.
- **Help** — Displays information about the currently selected device, component, or test.
- **Configuration** — Displays basic configuration information about the currently selected device.
- **Parameters** — Displays parameters that you can set for the test.





6

Jumpers and Connectors

System Board Jumper

For information on resetting the password jumper to disable a password, see "Disabling a Forgotten Password" on page 201.

Table 6-1. System Board Jumper Settings

Jumper	Setting	Description
PWRD_EN	 (default)	The password feature is enabled (pins 2-4)
		The password feature is disabled, and iDRAC6 local access is unlocked at the next AC power cycle (pins 4-6)
NVRAM_CLR	 (default)	The configuration settings are retained at system boot (pins 3-5)
		The configuration settings are cleared at the next system boot (pins 1-3)

System Board Connectors

Figure 6-1. System Board Connectors

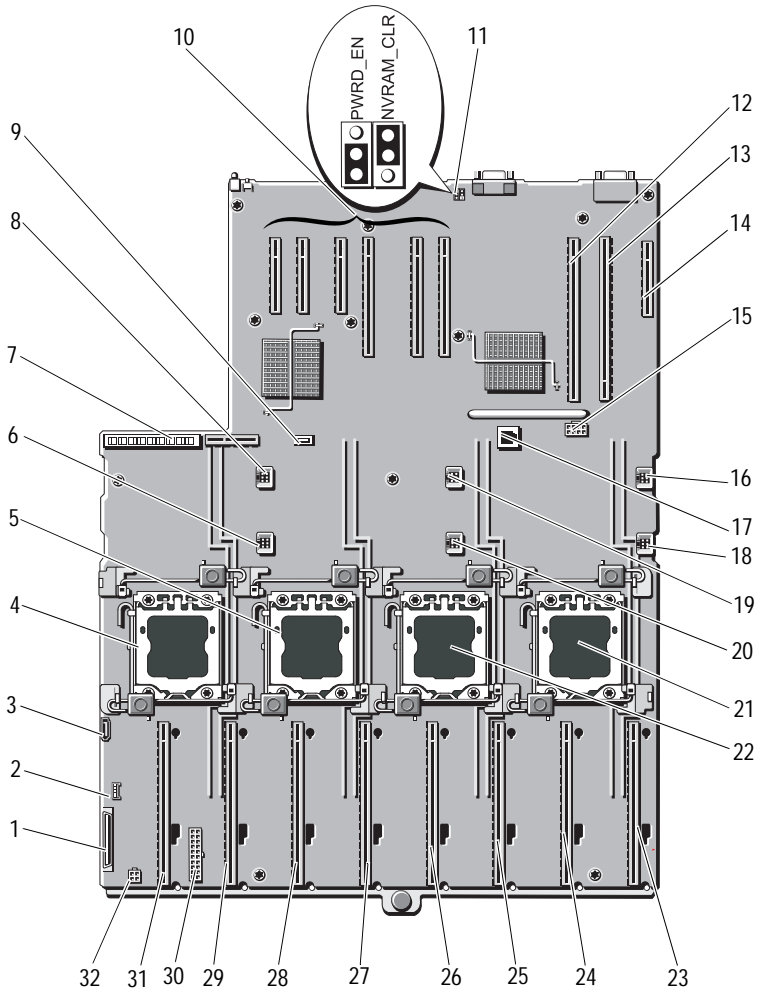

Table 6-2. System Board Jumpers and Connectors

Item	Connector	Description
1	CTRL_PNL	Control panel interface connector
2	CTRL_USB	Control panel USB interface connector
3	SATA_A	SATA A connector
4	J_CPU4	Processor 4
5	J_CPU2	Processor 2
6	FAN1	System cooling fan 1
7	J_PDB_MISC	Power distribution board connector
8	FAN4	System cooling fan 4
9	INT_USB	Internal USB connector
10	SLOT 1	PCIE_G2_X4
	SLOT2	PCIE_G2_X8
	SLOT3	PCIE_G2_X8
	SLOT4	PCIE_G2_X8
	SLOT5	PCIE_G2_X4
	SLOT6	PCIE_G2_X4
11	PWRD_EN	Password enable jumper
	NVRAM_CLR	NVRAM clear jumper
12	SLOT7	PCIE_G2_X16
13	IO_RISER	I/O card connector
14	INT_STORAGE	Internal storage controller card connector
15	J_SLOT7PWR	Power connector
16	FAN5	System cooling fan 5
17	ISCSI_KEY	NIC hardware key
18	FAN2	System cooling fan 2
19	FAN6	System cooling fan 6
20	FAN3	System cooling fan 3
21	J_CPU3	Processor 3

Table 6-2. System Board Jumpers and Connectors

Item	Connector	Description
22	J_CPU1	Processor 1
23	MEM_RISER_A	Memory riser A connector
24	MEM_RISER_B	Memory riser B connector
25	MEM_RISER_E	Memory riser E connector
26	MEM_RISER_F	Memory riser F connector
27	MEM_RISER_C	Memory riser C connector
28	MEM_RISER_D	Memory riser D connector
29	MEM_RISER_G	Memory riser G connector
30	BP_PWR/MISC	Power connector
31	MEM_RISER_H	Memory riser H connector
32	SATA_PWR	SATA power connector

SAS Backplane Board Connectors

Figure 6-2. x16 SAS Backplane Board Connectors

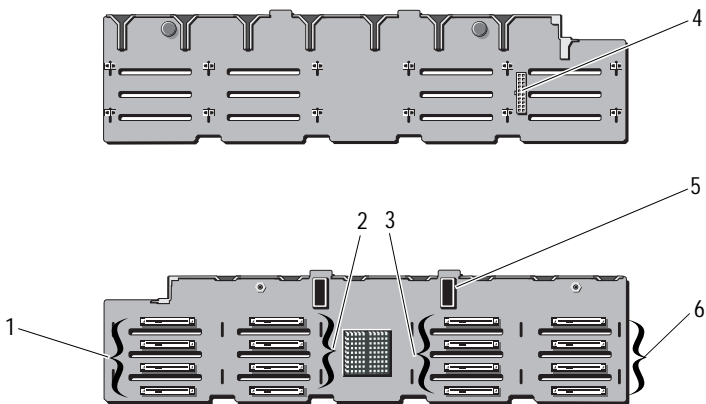

- | | | | |
|---|----------------------------|---|-----------------------------|
| 1 | hard-drive connectors 0–3 | 2 | hard-drive connectors 4–7 |
| 3 | hard-drive connectors 8–11 | 4 | power connector |
| 5 | SAS connectors (2) | 6 | hard-drive connectors 12–15 |

Figure 6-3. x4 SAS Backplane Board Connectors

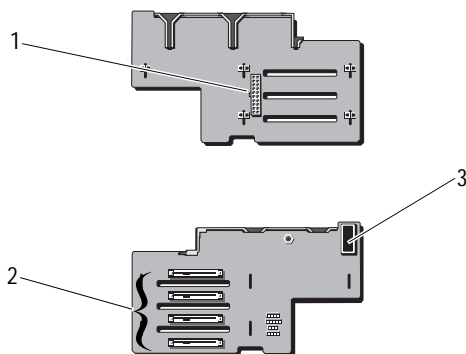

- | | | | |
|---|-----------------|---|---------------------------|
| 1 | power connector | 2 | hard-drive connectors 0–3 |
| 3 | SAS connector | | |

Disabling a Forgotten Password

The system's software security features include a system password and a setup password, which are discussed in detail in "Using the System Setup Program and UEFI Boot Manager" on page 63. The password jumper enables these password features or disables them and clears any password(s) currently in use.

⚠ CAUTION: See "Protecting Against Electrostatic Discharge" in the safety instructions that came with the system.

- 1 Turn off the system, including any attached peripherals, and disconnect the system from the electrical outlet.
- 2 Open the system. See "Opening the System" on page 89.

- 3 Remove the jumper plug from the password jumper.

See Figure 6-1 to locate the password jumper (labeled "PWRD_EN") on the system board.

- 4 Close the system.
- 5 Reconnect your system and peripherals to their electrical outlets, and turn on the system.

The existing passwords are not disabled (erased) until the system boots with the password jumper plug removed. However, before you assign a new system and/or setup password, you must install the jumper plug.



NOTE: If you assign a new system and/or setup password with the jumper plug still removed, the system disables the new password(s) the next time it boots.

- 6 Turn off the system, including any attached peripherals, and disconnect the system from the electrical outlet.
- 7 Open the system. See "Closing the System" on page 90.
- 8 Install the jumper plug on the password jumper.
- 9 Lower the memory module shroud.
- 10 Close the system.
- 11 Reconnect your system and peripherals to their electrical outlets, and turn on the system.
- 12 Assign a new system and/or setup password.

To assign a new password using the System Setup program, see "Assigning a System Password" on page 79.

Getting Help

Contacting Dell

For customers in the United States, call 800-WWW-DELL (800-999-3355).



NOTE: If you do not have an active Internet connection, you can find contact information on your purchase invoice, packing slip, bill, or Dell product catalog.

Dell provides several online and telephone-based support and service options. Availability varies by country and product, and some services may not be available in your area. To contact Dell for sales, technical support, or customer service issues:

- 1 Visit **support.dell.com**.
- 2 Verify your country or region in the **Choose A Country/Region** drop-down menu at the bottom of the page.
- 3 Click **Contact Us** on the left side of the page.
- 4 Select the appropriate service or support link based on your need.
- 5 Choose the method of contacting Dell that is convenient for you.

Index

B

- batteries
 - troubleshooting, 178
- battery
 - troubleshooting the RAID card battery, 187
- battery (system)
 - replacing, 157
- blank
 - hard drive, 108
 - power supply, 157

C

- cabling
 - optical drive, 113
- CD drive
 - troubleshooting, 185
- CD/DVD drive
 - See* optical drive.
- connectors
 - USB, 12, 19
 - video, 12, 19
- contacting Dell, 203
- control panel assembly
 - features, 12
 - LCD panel features, 14
- cooling fans

troubleshooting, 180

D

- damaged systems
 - troubleshooting, 177
- Dell
 - contacting, 203
- Dell PowerEdge Diagnostics
 - using, 193
- diagnostics
 - advanced testing options, 193
 - testing options, 193
 - using Dell PowerEdge Diagnostics, 193
- DIMMs
 - See* memory modules (DIMMs).
- drive blank
 - installing, 108
 - removing, 108
- drive carrier
 - hard drive, 112

E

- error messages, 64
- expansion card
 - troubleshooting, 189

- expansion cards
 - installing, 126
 - removing, 128, 134
 - SAS controller, 143
- expansion slots, 124

F

- front bezel
 - installing, 87
 - removing, 87
- front-panel features, 12

G

- guidelines
 - connecting external devices, 21
 - expansion card installation, 124
 - memory installation, 92

H

- hard drive
 - drive carrier, 112
 - installing, 110
 - removing, 109
 - troubleshooting, 186
- heat sink, 150
- hot-swap
 - hard drives, 107

I

- iDRAC card
 - installing, 136
- iDRAC Configuration Utility, 83
- indicators
 - front-panel, 12
 - NIC, 21
 - power, 12, 22
- installing
 - expansion card, 126
 - front bezel, 87
 - hard drive blank, 108
 - hard drives, 110
 - iDRAC card, 136
 - memory modules, 102
 - optical drive, 113
 - power supply blank, 157
 - SAS backplane board, 161
 - SAS controller, 145

K

- keyboards
 - troubleshooting, 174

L

- LCD panel
 - features, 14
 - menus, 15

M

- memory
 - troubleshooting, 181
- memory key connector (USB), 120
- Memory Mirroring memory mode, 92
- memory mode
 - memory mirroring, 92
- memory modules (DIMMs)
 - configuring, 92
 - installing, 102
 - RDIMM configurations, 93
 - removing, 105
 - UDIMM configurations, 125
- memory riser, 100
 - installing, 101
 - removing, 100
- memory-riser blank, 99
 - installing, 100
 - removing, 99
- messages
 - error messages, 64
 - status LCD, 23
 - system, 41
 - warning, 60

N

- NIC
 - indicators, 21
- NIC TOE, 123

- NICs
 - troubleshooting, 175

O

- optical drive
 - installing, 113
- options
 - system setup, 65

P

- password
 - disabling, 201
 - setup, 81
 - system, 79
- phone numbers, 203
- POST
 - accessing system features, 11
- power indicators, 12, 22
- power supplies
 - indicators, 22
 - removing, 155
 - replacing, 156
 - troubleshooting, 179
- power supply blank, 157
- processors
 - troubleshooting, 190

R

- recommended tools, 85

- removing
 - expansion card, 128, 134
 - front bezel, 87
 - hard drive blank, 108
 - hard drive from a drive carrier, 112
 - hard drives, 109
 - memory modules, 105
 - power supply, 155
 - power supply blank, 157
 - SAS backplane board, 159
 - SAS controller, 143
 - system board, 168
- replacing
 - power supply, 156
 - system battery, 157

S

- safety, 173
- SAS backplane board
 - installing, 161
 - removing, 159
- SAS controller card
 - installing, 145
 - removing, 143
- SAS controller daughter card
 - troubleshooting, 187
- SAS RAID controller daughter card
 - troubleshooting, 187
- SD card
 - troubleshooting, 183
- securing your system, 74, 80
- service-only procedure
 - system board, 168
- setup password, 81
- slots
 - See* expansion slots.
- startup
 - accessing system features, 11
- support
 - contacting Dell, 203
- system board
 - installing, 170
 - removing, 168
- system cooling
 - troubleshooting, 180
- system features
 - accessing, 11
- system messages, 41
- system password, 79
- system setup
 - options, 65
- system setup program
 - boot settings, 69
 - embedded server management options, 73
 - entering, 64
 - integrated devices options, 70
 - keystroke, 64
 - memory settings, 67
 - PCI IRQ assignments, 71
 - power management options, 73
 - processor settings, 68
 - SATA settings, 69

- serial communications
 - options, 72
- system security options, 74
- system setup screens
 - main, 65
- system startup failure, 173

T

- telephone numbers, 203
- TPM security, 74
- troubleshooting
 - battery, 178
 - CD drive, 185
 - cooling fans, 180
 - damaged system, 177
 - expansion card, 189
 - external connections, 173
 - hard drive, 186
 - internal USB key, 183
 - keyboard, 174
 - memory, 181
 - NIC, 175
 - power supplies, 179
 - SAS RAID controller daughter card, 187
 - SD card, 183
 - system cooling, 180
 - system startup failure, 173
 - video, 174
 - wet system, 176

U

- UEFI Boot Manager
 - entering, 76
 - main screen, 77
 - System Utilities screen, 78
 - UEFI Boot Settings screen, 77

USB

- front-panel connectors, 12
- internal connector for memory key, 120

USB key

- troubleshooting, 183

V

video

- front-panel connectors, 12
- troubleshooting, 174

W

- warning messages, 60
- warranty, 60
- wet system
 - troubleshooting, 176

