

Dell EqualLogic PS4210 Storage Arrays Installation and Setup Guide



Dell EqualLogic PS4210 Storage Arrays

Installation and Setup Guide

Version 1.0

Regulatory Model Series E03J and E04J

© Copyright 2014 Dell Inc. All rights reserved.

Dell™ and EqualLogic® are trademarks of Dell Inc. All trademarks and registered trademarks mentioned herein are the property of their respective owners.

Information in this document is subject to change without notice.

Reproduction of this material in any manner whatsoever without the written permission of Dell is strictly forbidden.

Published: October 2014

Part Number: M40C6-A00

Table of Contents

Preface	v
1 Understanding the Array Installation Procedure	1
2 Rack Mounting the Array	3
Before You Begin	3
Protecting Hardware	4
Steps for Mounting an Array in a Rack	6
3 Connecting the Array Cables	9
Network Requirements and Recommendations	9
Minimum and Recommended Cable Configurations	10
Connect and Secure the Power Cables	11
Connect the Array to the Network	12
Set Up a Serial Connection to the Array	13
4 Software Configuration	17
Choose a Configuration Method	17
Collect Configuration Information	17
Start the Software Configuration	18
Set the Member RAID Policy	21
5 Storage Allocation	23
Create a Volume	23
Connect a Computer to a Volume	27
6 Where to Go After Setting Up a Group	29
Common Group Customization Tasks	29
7 Other Information You Might Need	31
NOM Information (Mexico Only)	31
Index	35

Preface

Dell™ EqualLogic® PS Series arrays optimize resources by automating capacity, performance, and network load balancing. Additionally, PS Series arrays offer all-inclusive array management software and firmware updates. Dell EqualLogic FS Series appliances, combined with PS Series arrays, offer a high-performance, high-availability, scalable NAS solution.

Audience

The information in this guide is intended for hardware administrators. Administrators are not required to have extensive network or storage system experience. However, it is helpful to understand:

- Basic networking concepts
- Current network environment
- User disk storage requirements
- RAID configurations
- Disk storage management

Note: Although this manual provides examples of using PS Series arrays in some common network configurations, detailed information about setting up a network is beyond its scope.

Related Documentation

For detailed information about PS Series arrays, groups, volumes, array software, and host software:

1. Log in to the Dell EqualLogic support site (eqlsupport.dell.com).
2. Select **Downloads**.
3. From the drop-down list, choose **PS Series Firmware**.
4. Under Recommended PS Series Firmware, select the required version. The link to the download page appears.
5. Click the **Download** page link.
6. Scroll down to Documentation.

Dell Online Services

You can learn about Dell products and services by visiting dell.com (or the URL specified in any Dell product information).

To learn more about Dell EqualLogic products and new releases, visit the Dell EqualLogic Tech Center site: delltechcenter.com/page/EqualLogic. Here you can also see articles, demos, online discussions, and more details about the benefits of our product family.

Technical Support and Customer Service

Dell's support service is available to answer your questions about PS Series SAN arrays. If you have an Express Service Code, have it ready when you call. The code helps Dell's automated-support telephone system direct your call more efficiently.

Contacting Dell

Dell provides several online and telephone-based support and service options. Availability varies by country and product, and some services might not be available in your area.

To contact Dell EqualLogic Technical Support by phone, if you are located in the United States, call 800-945-3355. For a listing of International Dell EqualLogic support numbers, visit dell.com/support/home. From this website, select your country from the drop-down list in the upper left corner of the screen. If you do not have access to an Internet connection, contact information is printed on your invoice, packing slip, bill, or Dell product catalog.

Use the following procedure to register for an EqualLogic customer support account, to log cases via the web, and to obtain software updates, further documentation and resources.

1. Visit eqsupport.dell.com or the Dell support URL specified in information provided with the Dell product.
2. Select the required service. Click the `Contact Us` link, or select the Dell support service from the list of services provided.
3. Choose your preferred method of contacting Dell support, such as e-mail or telephone.

Warranty Information

The PS4210 array warranty is included in the shipping box. For information about registering a warranty, visit <https://eqsupport.dell.com/utility/form.aspx?source=warranty>.

Notes, Cautions, and Warnings Symbols



A NOTE symbol indicates important information that helps you make better use of your hardware or software.



A CAUTION symbol indicates potential damage to hardware or loss of data if instructions are not followed.



A WARNING symbol indicates a potential for property damage, personal injury, or death.

Further Information

For basic storage array information, maintenance information, and troubleshooting information, refer to the PS4210 Hardware Owner's Manual.

1 Understanding the Array Installation Procedure

To set up your array and start using the iSCSI SAN array, follow these steps:

1. Install the array in a rack. See [Rack Mounting the Array on page 3](#).
2. Connect the array to power and the network. See [Connect and Secure the Power Cables on page 11](#) and [Connect the Array to the Network on page 12](#).
3. Configure the PS Series software. First, initialize an array to make it accessible on the network. Then, either create a group with the array as the first group member or add the array to an existing group. When you expand a group, capacity and performance increase automatically. See [Choose a Configuration Method on page 17](#).
4. Start using the iSCSI SAN array. Allocate group storage space to users and applications by creating volumes. A volume appears on the network as an iSCSI target. Use a computer's iSCSI initiator to connect to a volume. After you connect to a volume, it appears as a regular disk on the computer. See [Storage Allocation on page 23](#).

After getting started, you can customize the group and use its more advanced features. See [Where to Go After Setting Up a Group on page 29](#).

2 Rack Mounting the Array

For proper operation, a PS Series storage array must be properly installed in a rack. This section contains general electrostatic, safety, network, and installation information for PS Series arrays.

After installing the array in a rack, connect the power and network cables, as described in [Chapter 3](#).

Before You Begin

Before installing the array:

- Register for a Dell™ EqualLogic® Customer Support Account. If you do not have a customer service support account, go to eqlsupport.dell.com and create one.
- Download and read the Release Notes from the Support Site. The *PS Series Storage Arrays Release Notes* contain the latest product information.
- Read the installation safety precautions. See [Installation Safety Precautions on page 3](#).
- Make sure the rack meets the rack requirements. See [Rack Requirements on page 3](#).
- Make sure the array and installation location meet the environmental requirements. See [Environmental Requirements on page 4](#).
- Unpack the rail kit (if ordered) and make sure you have all the necessary parts and tools. The rail kit is located in the array shipping box. You must supply your own tools. See [Shipping Box Contents and Required Hardware on page 5](#).

Installation Safety Precautions

Follow these safety precautions:

- Dell recommends that only individuals with rack-mounting experience install an array in a rack.
- Make sure the array is fully grounded at all times to prevent damage from electrostatic discharge.
- When handling the array hardware, you must use the electrostatic wrist guard shipped with the array or a similar form of protection.
- You need at least two people to lift the array chassis from the shipping box.

Rack Requirements

The rack and the array installation must meet the following requirements:

- Use an industry-standard, EIA-310-D compliant, four-post 19-inch rack with universal square hole or unthreaded round hole spacing.
- The rack is rated for 540 kg (1200 pounds) static load or greater.
- The minimum rack depth is 100 cm (40 inches) from the front of the rack to the rear of the rack.

- For the ReadyRails™ II rail kits, the distance between the outside surfaces of the front and rear rack posts (the mounting surfaces) can range from 595 mm to 914 mm (23.4" to 36.0") for square-hole racks, 581 mm to 907 mm (22.9" to 35.7") for round-hole racks, and 595 mm to 929 mm (23.4" to 36.6") for threaded-hole racks.
- The rack is secured to the floor for added stability.
- Load a rack with arrays from the bottom to the top.
- There is at least 4.1 cm (1.6 inches) between the rack door and the front of the array to accommodate the array front bezel.
- The rack (with installed arrays) meets the safety requirements of UL 60950-1 and IEC 60950-1, available at ulstandardsinfontet.ul.com/scopes/scopes.asp?fn=60950-1.html.
- Mount the array in a horizontal orientation or you will void your array warranty and support contract.

Environmental Requirements

The rack location must meet the following environmental requirements:

- The power source can supply a voltage range of 100V to 240V AC.
- The power source has sufficient electrical overload protection:
 - In North America, connect the array to a source of power with over-current protection provided by a double pole 20A or less device (UL 489 circuit breakers).
 - In Europe, the over-current protection must be provided by a 20A or less device (IEC circuit breakers).
- There is sufficient space for airflow in front of and behind the array.
- The location is properly vented.
- Your environment supports all of the requirements listed in the *Technical Specifications on page 31*.

Protecting Hardware

Protect your PS Series array from electrostatic discharge. When handling array hardware, use an electrostatic wrist strap or a similar form of protection. To use a wrist strap:

1. Connect the steel snap on the coil cord to the stud on the elastic band. See [Figure 1](#).

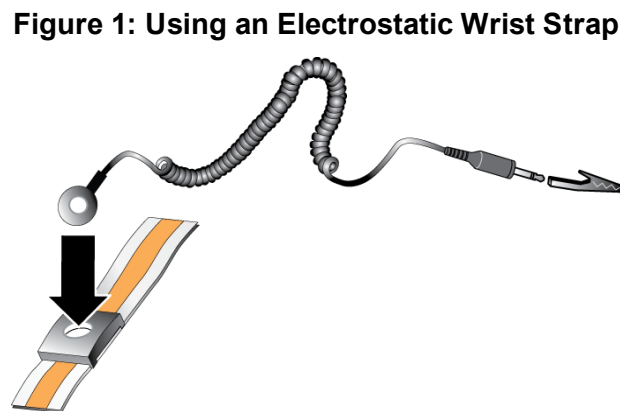

2. Fit the band tightly around your wrist.

3. Connect the band to ground. You can either plug the banana connector into a matching grounded receptacle, or attach it to the matching alligator clip and connect the clip to a grounded device. Examples of an appropriate ground would be an ESD mat or the metal frame of a grounded piece of equipment.

Shipping Box Contents and Required Hardware

Make sure you have all the items supplied in the shipping box, described in [Table 1](#). You must provide additional hardware that is specific to your environment and not included in the shipping box. See [Table 2](#).

Table 1: Shipping Box Contents

Component	Description
PS Series Array	<ul style="list-style-type: none"> • Two Type 19 control modules • Two power supply and cooling modules • Up to 24 2.5-inch 10K or 12 3.5-inch 7.2K serial-attached SCSI (SAS, Nearline SAS [NL-SAS], or Solid State (SSD) drives, depending on the model suffix
Bezel	The bezel mounts to the front of the array. The bezel identifies the array model and protects the drives from unauthorized or accidental removal.
Power cables	Connects an array power supply to power sources. If power cables are not included in the shipping box, contact your PS Series array support provider or reseller.
One or two serial cables	Creates a serial connection between an array and a console or terminal emulator. Use the cable to run the <code>setup</code> utility if there is no network access to the array or group.
Documentation	<p>The following documentation is included in the shipping box:</p> <ul style="list-style-type: none"> • Setup poster • Installation and Setup Guide (this document) • License, regulatory, and warranty information • Safety, Environmental, and Regulatory Information booklet

Table 2: Additional Hardware Required (Not Included)

Component	Description
Standard 19-in. four-post rack	Provides easy access to arrays and other hardware in your computing environment.
10/100Mbps Ethernet cables	For use with a dedicated management network. Connects the Management port on the array to a 10/100Mbps network switch. Use Category 5E or Category 6 cables with RJ45 connectors. Use Category 5 cables only if they meet the TIA/EIA TSB95 standard.
Network switch	Connects devices (array) to a network. Multiple switches are recommended. Switch provides 10GBASE-T interfaces to use the 10GBASE-T port, or an SFP+ switch to use the SFP+ port.
CAT6 or CAT6A cables	For 10GBASE-T port, use Category 6 (or better) cable for up to 55 meters. Use Category 6A cable for up to 100 meters.
Optical or copper cables	For SFP+ port, use optical cable or copper SFP+ cable.

Optional Hardware

You can optionally use an uninterruptible power supply system (UPS) to provide a highly available source of power to an array. Each UPS (not included) should be on a different circuit and must provide the correct type of voltage for an adequate amount of time.

Steps for Mounting an Array in a Rack

To mount an array in a rack, follow these steps:

1. Determine where to place the mounting rails in the rack.
2. Attach the mounting rails to the rack.
3. Slide the chassis into the rack.
4. Attach the chassis to the front of the mounting rails.
5. Install the bezel.

These steps are described in detail in the following sections.

Determine Where to Place the Mounting Rails in the Rack

Make sure there is enough space in the rack for the chassis. In a standard rack, a 2U chassis will span six holes.

Installing the Rails and Array in a Rack

Install the rails in the rack following the safety instructions and the rack installation instructions provided with your rail kit.

If installed in a closed or multi-unit rack assembly, the operating temperature of the rack environment might be greater than room ambient. Therefore, make sure you install the array in an environment compatible with the maximum temperature specified by the manufacturer. For more information, see [Technical Specifications on page 31](#).

Slide the Array into the Rack

Slide the array into the rack as shown in [Figure 2](#).

Figure 2: Installing the Array Into the Rack

Figure 3 shows the front view of the 3.5-inch drive array.

Figure 3: 3.5-Inch Drive Array - Front View (Without Bezel)

Figure 4 shows the front view of the 2.5-inch drive array.

Figure 4: 2.5-Inch Drive Array - Front View (Without Bezel)

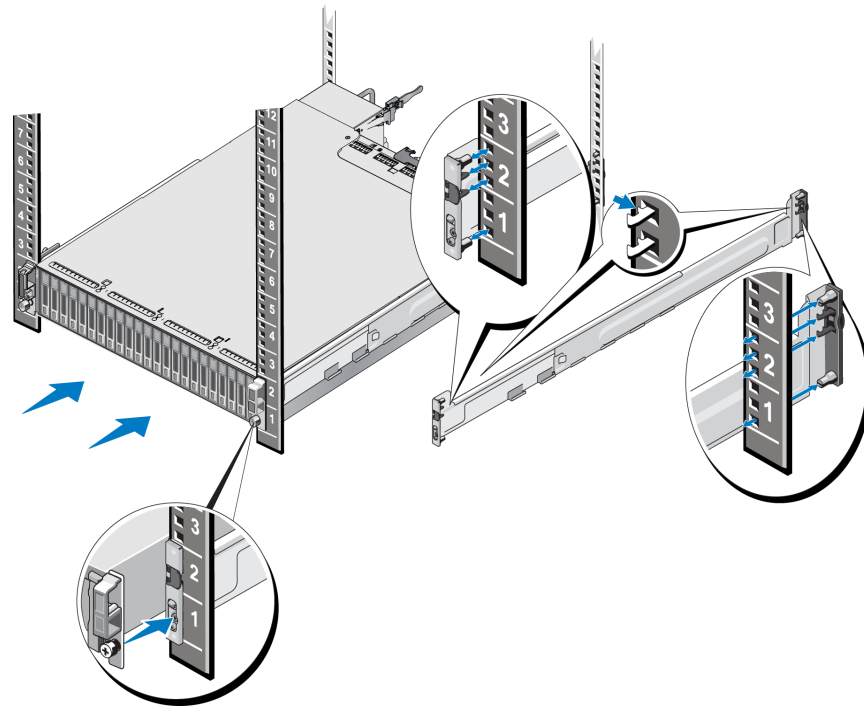
With assistance, lift the array, keeping the array level, and slide it onto the mounting rails until the array engages.

Attach the Array to the Mounting Rails

Make sure the array captive fasteners on the front of the array line up with the threaded holes on the front of the mounting rails, and *manually* secure the captive fasteners to the rails.

Note: Do not overtighten the thumbscrews.

Installing the Bezel

The steps for installing the bezel are the same for all array models:

1. Hook the right end of the bezel onto the right side of the chassis.
2. Swing the left end of the bezel toward the left side of the chassis.
3. Press the bezel into place until the release latch closes.
4. Using the key provided, lock the bezel and store the key in a safe place as shown in [Figure 5](#).

Figure 5: Installing the Bezel

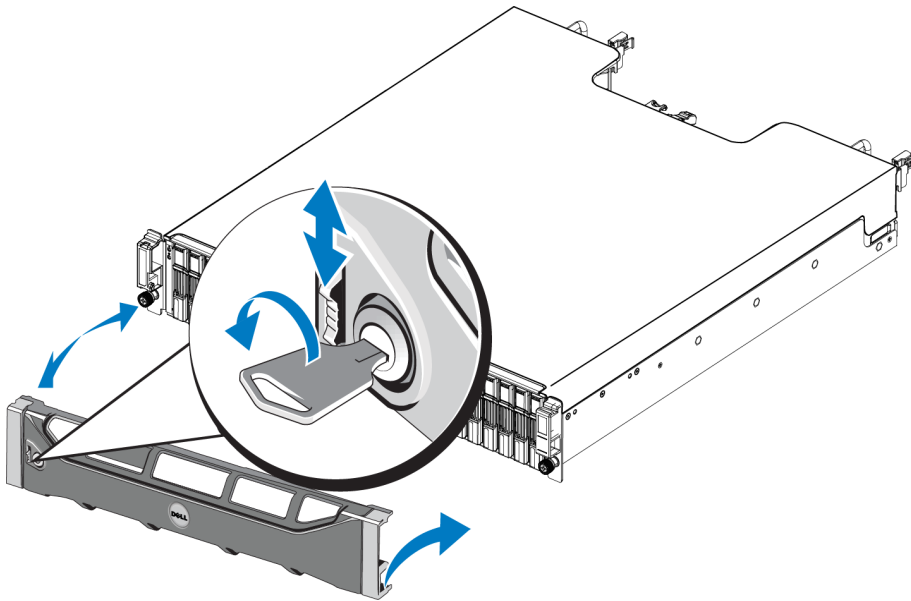

3 Connecting the Array Cables

After you install the array in a rack, you must connect the network and power cables and, optionally, the serial cables.

First, review the network recommendations in *Minimum and Recommended Cable Configurations on page 10*.

The following list describes the general steps for connecting the array to power and the network:

1. Connect the power cables. Do *not* turn on power to the array at this time. See *Connect and Secure the Power Cables on page 11*.
2. Connect the array to the network. See *Connect the Array to the Network on page 12*.
3. Turn on power to the array. See *Turning On the Array on page 12*.

The following sections describe these steps in detail. After completing the steps, see *Software Configuration on page 17*.

Network Requirements and Recommendations

The minimum network configuration for a PS Series array consists of a connection between Ethernet 0 on each control module and a computer connected to a network switch. To increase performance and availability, configure multiple network interfaces on an array and connect them to multiple switches.

Network recommendations are described in [Table 3](#). In addition, all the usual rules for proper network configuration apply to PS Series arrays. For more information about network requirements, see the Dell EqualLogic Configuration Guide on the Dell TechCenter website at en.community.dell.com/techcenter/storage/w/wiki/2639.equallogic-configuration-guide.aspx.

General network configuration is beyond the scope of this manual.

Table 3: Network Recommendations

Recommendation	Description
Switched 10GbE network	Connect arrays and computers to a switched network and ensure that all network connections between computers and arrays are 10GbE. Use optical cables with optical SFP+ plug-in modules, or copper cables with integrated SFP+ modules. 10GBASE-T requires Cat 6 minimally, but Cat 6A is recommended. Requires a switch with 10GBASE-T interfaces to use the 10GBASE-T port, or an SFP+ switch to use the SFP+ port.
Multiple network connections to different network switches	For increased bandwidth and availability, connect each control module to two different switches. The switches must be connected using interswitch links or by stacking capability. The links must have sufficient bandwidth to handle the iSCSI traffic. Review the EqualLogic Configuration Guide for interswitch link sizing recommendations. After connecting the network interfaces, use the Group Manager GUI or CLI to assign an IP address, netmask, and gateway address to each interface.

Recommendation	Description
Management network (optional)	Connect the management ports on both control modules to a 10/100Mbps network switch to keep management traffic separate from iSCSI traffic.
Access to the group IP address (Hosts)	In a multi-subnet group, each configured network interface should have access to the subnet on which the group IP address resides.
For replication, a reliable, adequately sized network link	For effective and predictable replication, the network link between the primary and secondary groups must be reliable and provide sufficient bandwidth for copying data.
Use of spanning-tree protocol	<p>If possible, do not use Spanning Tree Protocol (STP) on switch ports that connect end nodes (iSCSI initiators or array network interfaces).</p> <p>If you must use STP or RSTP (STP is preferable), enable the port settings (available on some switches) that let the port immediately transition into STP forwarding state upon link up. This functionality can reduce network interruptions that occur when devices restart, and should be enabled only on switch ports that connect end nodes.</p> <p>You can use STP for a single-cable connection between switches and trunking for multicable connections between switches.</p>
VLANs	To use DCB (Data Center Bridging), configure switches to use VLANs to separate iSCSI SAN traffic from other network traffic.
DCB	You must have VLANs enabled. Refer to the <i>Dell EqualLogic Group Manager Administrator's Manual</i> , and the <i>Dell EqualLogic Group Manager CLI Reference Guide</i> for more information about DCB.

Minimum and Recommended Cable Configurations

For a dual control module array, the recommended configuration is to connect network cables to Ethernet 0 on both control modules, and connect each control module to a network switch.

For high performance and availability, distribute the connections across multiple network switches.

The switches must be connected with interswitch links that have sufficient bandwidth to handle the iSCSI traffic, or by stacking capability. Dell recommends using stacking configurations wherever possible.

[Figure 6](#) illustrates the recommended network configuration alternatives.

Note: Dell does not recommend connecting both the SFP+ and 10GBASE-T Ethernet ports at the same time.

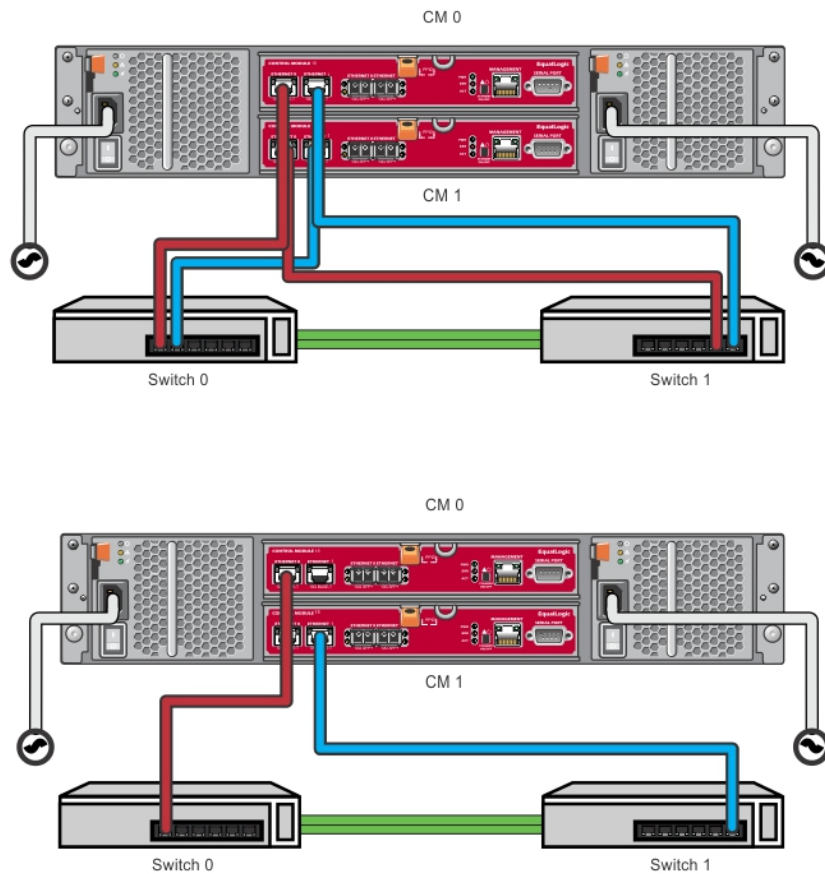
Figure 6: Recommended Network Configurations

Connect and Secure the Power Cables

Obtain the power cables that were shipped with the array. If the array was not shipped with power cables, contact your PS Series support provider or reseller for power cable information.

1. Make sure that the power switch is in the OFF (O) position before connecting the power cables.
2. Connect the power cables to the power supplies as shown in .
3. Secure the power cables to the system:
 - a. Secure the power cables firmly to the bracket next to the system power receptacle using the provided hook-and-loop strap.
 - b. Make sure the strap is tightly bound to the bracket anchor point (remove any slack).
 - c. Bias the power cable toward the strap and wrap the strap tightly around the cable against the shoulder of the power cable connector.
4. Attach the power cables to a power source:

- Plug the power cables into a grounded electrical outlet or a separate power source such as an uninterruptible power supply (UPS) or a power distribution unit (PDU). The bottom LED of the power supply will be illuminated green (indicating power is present) when power cables are connected.
- Each UPS (not included) should be on a different circuit and must provide the correct type of voltage for an adequate amount of time.
- Alternately, connect one power supply and cooling module to a UPS system and connect the other module to a different source of power.

Caution: Do not turn on power to the array yet.

Figure 7: Connecting the AC Power Cables

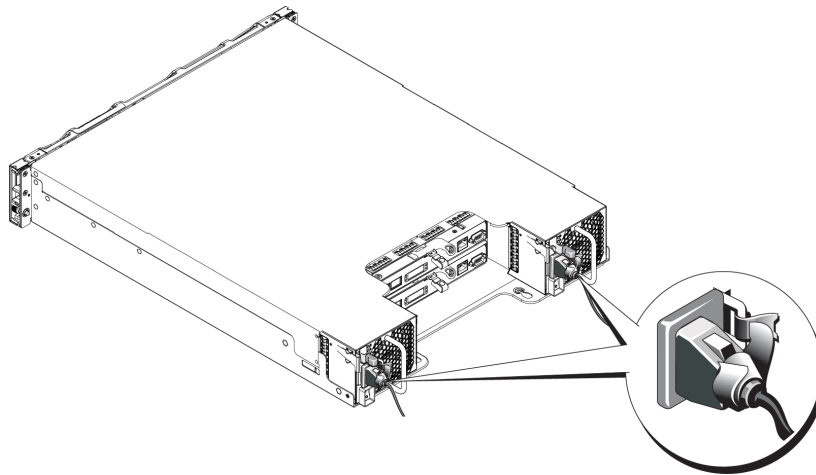

Connect the Array to the Network

The PS4210 array model includes two Type 19 control modules. Each Type 19 control module includes two 10Gbase-T ports and two 10Gbe SFP+ ports. Of each pair, one is labeled Ethernet 0 and the other is labeled Ethernet 1.

The control modules also include one 10Mb/100Mb port labeled Management. The management port cannot carry iSCSI traffic. Use the management port only if you configure a management network. See the *Dell EqualLogic Group Manager Administrator's Manual* for more information.

Obtain the appropriate number of copper or optical 10GbE network cables.

Note: Optical cables transmit data through pulses of light. It is very important to route all optical cables with no more than a 4-inch bend radius at any point between the array and the switch.

One functioning network connection is required for array operation. Multiple network connections are recommended for performance and high availability. See [Minimum and Recommended Cable Configurations on page 10](#) for additional information.

Turning On the Array

Before turning on power, allow sufficient time for the array to adjust to ambient temperature (for example, overnight).

Note: You can turn on the power to one power supply first (either one), or both at the same time.

1. Find the power switch, located either below the power plug. See [Figure 8](#).
2. Press the power switch to the ON position. The power indicators will light.

Batteries will start to charge and some hardware components will start to synchronize. LEDs will indicate these normal activities. The battery backup unit installed in each controller is shipped in a partially discharged state.

The first time the system is powered on, a boot delay of up to 30 minutes might be experienced while the battery is charged to full capacity.

The location of the LEDs is shown in the following illustration. [Table 4](#) provides LED descriptions.

Figure 8: AC Power Supply Switch and LEDs

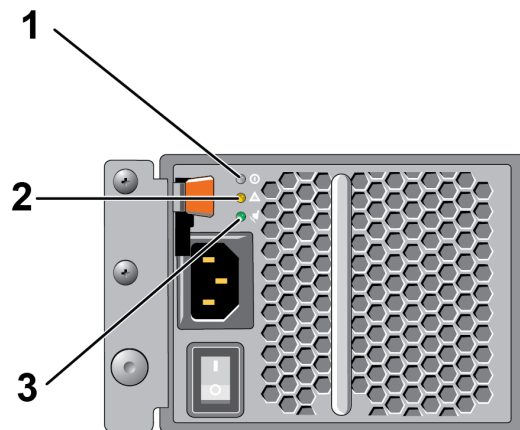

Table 4: Power Supply LED Descriptions

Callout	Description
1	Power Supply status. This LED is lit (green) when the switch is on and the power supply is providing power to the array.
2	Error. This LED is lit (amber) if the power supply has a problem.
3	Input Power. This LED is lit (green) as long as main power is connected to the power supply.

Set Up a Serial Connection to the Array

If you plan to use the `setup` utility to configure the software, you must set up a serial connection between the array and a computer. If you plan to use the Remote Setup wizard, you do not need a serial connection. For information about Remote Setup wizard requirements, see the *Host Integration Tool for Microsoft® Installation and User's Guide* or the *Host Integration Tool for Linux® Installation and User's Guide*.

The serial cable shipped with the array is a standard null-modem cable with a female DB9 connector on each end. You might have to make or buy an adapter cable (one DB9 connector and one RJ45 connector) to connect the array to some terminal server models. See [Serial Cable Pinout Information on page 15](#).

Attach the cable to the serial port on the active control module and to a console terminal or a computer running a terminal emulator. The active control module has two green LEDs and the secondary control module has one green and one amber LED.

See [Figure 9](#) (not to scale).

The serial connection must have the following characteristics:

- 9600 baud
- One STOP bit
- No parity
- 8 data bits
- No flow control

Note: Keep the serial cable. You need the serial cable to manage the group, or a specific array, if there is no network access.

Figure 9: Connecting a Serial Cable to the Array

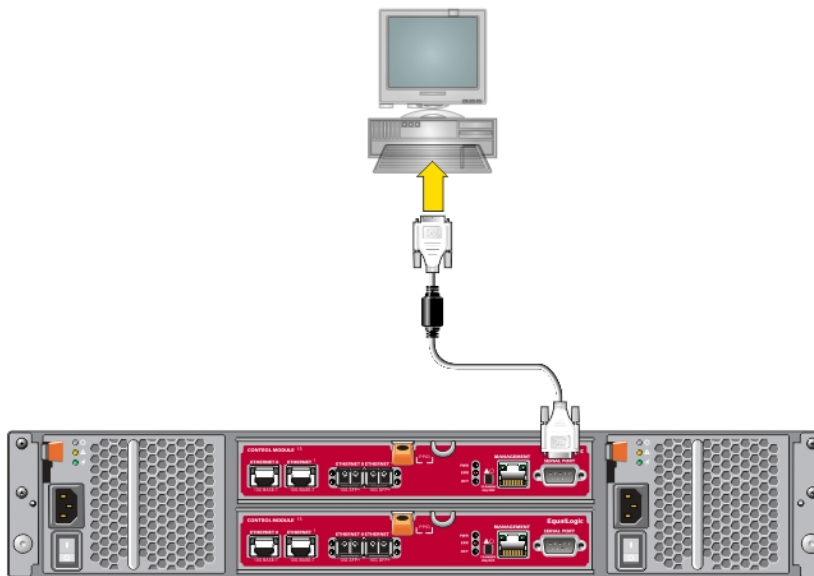

Serial Cable Pinout Information

Figure 10 shows the pin locations on the DB9 connectors on the serial cable shipped with the array, and Table 5 lists the pinout information for the cable.

Figure 10: Serial Cable DB9 Connector - Pin Locations

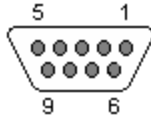

Table 5: DB9 to DB9 Pinout Information

DB9-1		DB9-2	
Function	Pin	Pin	Function
Receive Data	2	3	Transmit Data
Transmit Data	3	2	Receive Data
Data Terminal Ready	4	6+1	Data Set Ready + Carrier Detect
System Ground	5	5	System Ground
Data Set Ready + Carrier Detect	6+1	4	Data Terminal Ready
Request to Send	7	8	Clear to Send
Clear to Send	8	7	Request to Send

4 Software Configuration

After you complete the array hardware installation, you can initialize the array and create a PS Series group with the array as the first group member. Alternately, you can add the array to an existing group. When you expand a group, capacity and performance scale automatically with no impact on users.

After completing the software configuration, you can allocate storage and start using the iSCSI SAN array. See [Storage Allocation on page 23](#).

Choose a Configuration Method

There are two methods for configuring the software. Choose *one* method:

- Use the Remote Setup wizard, either for Windows or Linux. For instructions about using the Remote Setup wizard, see the *Dell EqualLogic Host Integration Tools for Microsoft Installation and User's Guide* or the *Dell EqualLogic Host Integration Tool for Linux Installation and User's Guide*.
- Use the `setup` utility. The `setup` utility is an interactive, command line utility that prompts for information about the array and group configuration.
To use the `setup` utility, you must have a serial connection between the array and a console terminal or a computer running a terminal emulator.

After choosing a method, collect the information needed for the array configuration.

Collect Configuration Information

Regardless of the method you use to configure the software, you must collect the information in [Table 6](#) and [Table 7](#). Obtain IP addresses from your network administrator, as needed.

Also, make sure you follow the network recommendations in [Network Requirements and Recommendations on page 9](#).

Table 6: Array Configuration Information

Prompt	Description
Member name	Unique name for the array in the group (63 or fewer letters, numbers, or hyphens). First character must be a letter or number.
Network interface	Name of a network interface on the array (for example, eth0) that is connected to a functioning port on a network switch.
IP address	Network address for the array network interface. Note: Each member must have at least one network interface on the same subnet as the group IP address.
Netmask	Address that combines with the IP address to identify the subnet on which the array network interface resides (default is 255.255.255.0).

Prompt	Description
Default gateway (optional)	Network address for the device used to connect subnets and forward network traffic beyond the local network. A default gateway is needed only if you want the array network interface to communicate outside the local network (for example, to allow access to volumes from computers outside the local network). The default gateway must be on the same subnet as the array network interface.
RAID policy	RAID level and spare drive configuration for the array. The actual number of RAID sets and spare drives depends on the number of drives in the array. <ul style="list-style-type: none"> RAID 6 – Distributed dual-parity sets. RAID 10 – Striping on top of multiple RAID 1 (mirrored) sets. RAID 50 – Striping on top of multiple RAID 5 (distributed-parity) sets. Each RAID 5 set uses one drive's worth of space for parity. RAID 5 – Distributed-parity sets. RAID 5—[Not Recommended] One RAID 5 set, with one spare disk. RAID 5 is similar to RAID 50, with more capacity (two additional disks) but lower availability and performance. <p>Note: To configure RAID 50 with drives larger than 3TB, or RAID 5 with drives of any size, you must use the Group Manager CLI.</p>

Table 7: Group Configuration Information

Prompt	Description
Group name	Unique name that identifies the group (54 or fewer letters, numbers, or hyphens). The first character must be a letter or number.
Group IP address	Network address for the group. The group IP address is used for group administration and computer access to data stored in the group.
Password for adding members to a group	Password required when adding members to a group. The password must have 3 to 16 letters or numbers and is case-sensitive.
Password for the <code>grpadmin</code> account	Password that will override the factory-set group administration password (<code>grpadmin</code>) for the <code>grpadmin</code> account. The password must have 3 to 16 letters or numbers and is case-sensitive. Required only when creating a new group.
Microsoft service user name and password (optional)	CHAP user name and password used to enable Microsoft service such as VSS (Volume Shadow Copy Service) or VDS (Virtual Disk Service) access to the group. The user name must have 3 to 63 alphanumeric characters. The password must have 12 to 16 alphanumeric characters, and is case-sensitive. Microsoft services running on a computer must be allowed access to the group in order to create VSS snapshots in the group or use VDS. Applicable only when creating a group with the Remote Setup wizard.

Start the Software Configuration

Use the `setup` utility or the Remote Setup wizard to initialize the array and either create a group with the array as the first group member or add the array to an existing group.

After you complete the software configuration, the array becomes a member of a group and its disk storage is available for use.

Using the Setup Utility to Configure the Software

To use the `setup` utility to initialize an array and create or expand a group:

1. On the console or terminal emulator that has the serial connection to the array, press the `Enter` key.

Note: If the array does not respond, contact your PS Series support provider for information on how to proceed.
2. At the login prompt, enter `grpadmin` for both the account (login) name and the password. Passwords do not appear on the screen.
3. When prompted, enter `y` to start the `setup` utility.
4. When prompted, enter the array and group configuration information from [Collect Configuration Information on page 17](#). Press the `Enter` key to accept a default value. Enter a question mark (?) to get help.

Note: There may be a short delay after entering the group IP address as the array searches the network.

After `setup` completes, you must set the member's RAID policy in order to use the disk storage. Go to [Set the Member RAID Policy on page 21](#).

The following example shows using the `setup` utility to initialize an array and create a group.

EXAMPLE - Using the setup Utility

```
Login: grpadmin
Password: xxxxxxxx
```

The `setup` utility establishes the initial network and storage configuration for a storage array and then configures the array as a member or a new or existing group of arrays. For help, enter a question mark (?) at a prompt.

```
Welcome to Group Manager
Copyright 2014 Dell Inc.
```

```
It appears that the storage array has not been configured.
Would you like to configure the array now? (y/n) [n] y
Group Manager Setup Utility
Do you want to proceed (yes | no) [no]? yes
Initializing. This may take several minutes to complete.
Enter the network configuration for the array:
Member name []: member1
Network interface [eth0]: eth0
IP address for network interface []: 192.17.2.41
Netmask [255.255.255.0]:
Default gateway [192.17.2.1]:
Enter the name and IP address of the group that the array will join.
Group name []: group1
Group IP address []: 192.17.2.20
```

```

Searching to see if the group exists. This may take a few minutes.
The group does not exist or currently cannot be reached. Make sure you have
entered the correct group IP address and group name.
Do you want to create a new group (yes | no) [yes]? yes
Group Configuration
Group Name: group1
Group IP address: 192.17.2.20
Do you want to use the group settings shown above (yes | no) [yes]: yes
Password for managing group membership:
Retype password for verification:
Password for the default group administration account:
Retype password for verification:
Saving the configuration ...
Waiting for configuration to become active.....Done
Group member member1 now active in the group.
Group group1 has been created with one member.
Use the Group Manager GUI or CLI to set the RAID policy for the member. You can
then create a volume that a host can connect to using an iSCSI initiator.
group1>

```

Using the Remote Setup Wizard to Configure the Software

The Remote Setup wizard is located on the Host Integration Tools CD-ROM and must be installed on a Windows or a Linux computer. The *Host Integration Tools User Guide* provides detailed information about using the full capabilities of the Remote Setup wizard.

To run the Remote Setup wizard, follow these steps:

1. Use a computer that meets the requirements in [Choose a Configuration Method on page 17](#).
2. Obtain the Host Integration Tools CD-ROM from the shipping box, or download the Host Integration Tools kit from the support website.
3. Install the Remote Setup wizard following the instructions in the Host Integration Tools documentation.
4. Start the Remote Setup wizard by clicking:
Start, Programs, EqualLogic, Remote Setup Wizard
5. In the Welcome dialog box, select `Initialize a PS Series array` and click `Next`.
Note: If you cannot contact the array, check the network configuration. You might need to use the `setup` utility to configure the software.
6. Select the array that you want to initialize and click `Next`.
7. In the Initialize Array dialog box, enter the array configuration from [Collect Configuration Information on page 17](#) and choose to create a group or join an existing group. Then, click `Next`.
8. In the Create a New Group or Join an Existing Group dialog box, enter the group configuration information and click `Next`.
9. Click `Finish` to exit the wizard.

If you added the array to an existing group, you must set the member's RAID policy in order to use the disk storage. Go to [Set the Member RAID Policy on page 21](#).

If you created a new group, go to [Storage Allocation on page 23](#).

Set the Member RAID Policy

The storage space in a new group member (array) is not available until you configure a RAID policy on the member.

A RAID policy consists of a RAID level and a spare disk configuration. When you select a RAID policy, the member's disks are automatically configured with the selected RAID level and the appropriate number of spare disks.

If you used the Remote Setup wizard to create a group, the RAID policy for the first member is set according to your RAID policy selection when configuring the software, and the storage is ready to use. See [Storage Allocation on page 23](#).

If you used the `setup` utility to create or expand a group, or added the array to an existing group with the Remote Setup wizard, you must set the RAID policy for the group member.

Use either the Group Manager command line interface (CLI) or the graphical user interface (GUI) to set the RAID policy.

Using the CLI to Set the RAID Policy

To use the Group Manager CLI to set the RAID policy for a new group member:

1. Log in to the group, if you are not already logged in. (After the `setup` utility completes, you will still be logged in to the group.) Use one of the following methods to connect to the group:
 - Serial connection to a member. See [Set Up a Serial Connection to the Array on page 13](#).
 - Telnet or ssh connection to the group IP address.
2. At the login prompt, enter the `grpadmin` account name and the password that you specified when creating the group.
3. At the Group Manager command prompt, enter the following command to specify RAID 6, or RAID6-accelerated (available XS array models only), RAID 10, or RAID 50 for the `policy` variable:

```
member select member_name raid-policy policy
```

For example, the following command configures member1 with RAID 6:

```
member select member1 raid-policy raid6
```

Using the Group Manager GUI to Set the RAID Policy

For the latest information on browser support for the Group Manager GUI, see the PS Series [Release Notes](#).

After you add a member to a PS Series group, you must set the RAID policy for the member and choose the storage pool. The storage in the member is available after you set the RAID policy.

To use the GUI to set the RAID policy for a members, use the following procedure:

Procedure

1. Click **Group** and then click the group name to open the Group Summary window.
2. Expand **Members** and then double-click the member name. The GUI shows whether a member is configured or not.

3. Click `Yes` in the warning dialog box to open the Configure Member – General Settings dialog box.
4. Select the pool and click `Next`. If prompted, confirm you want to assign the member to the pool.
5. Select the RAID policy on the Configure Member – RAID Configuration dialog box.
6. (Optional) Select `Wait until the member storage initialization completes`.
7. Click `Next`.
8. Click `Finish` in the Configure Member – Summary dialog box.

Note: After initial RAID configuration, it takes a few minutes for Group Manager to display the total usable capacity. Group Manager might show a smaller amount until the process is complete.

5 Storage Allocation

Allocating group storage space to users involves the following steps:

1. [Create a Volume on page 23](#).
2. [Connect a Computer to a Volume on page 27](#).

After allocating storage, you can customize the group and use its more advanced features. See [Where to Go After Setting Up a Group on page 29](#).

Create a Volume

To allocate group storage space to users and applications, use the Group Manager CLI or GUI to create volumes. A volume appears on the network as an iSCSI target. When you create a volume, specify the information described in [Table 8](#).

Table 8: Volume Configuration Information

Component	Description
Volume name	A unique name, 63 or fewer characters (including letters, numbers, periods, hyphens, and colons). The volume name is appended to the end of the iSCSI target name, which is automatically generated for the volume. Access to a volume is always through the target name.
Volume size	The reported size of the volume as seen by iSCSI initiators. The minimum volume size is 15MB. Volume sizes are rounded up to the next multiple of 15MB.

Optionally, you can set aside space for volume snapshots or configure a volume with thin provisioning. However, thin provisioning is not appropriate for all storage environments. See the *Dell EqualLogic Group Manager Administrator's Guide* for information about advanced volume functionality.

Using the CLI to Create a Volume

1. Log in to the group.
Use one of these methods to connect to the group:
 - Serial connection to a member. See [Set Up a Serial Connection to the Array on page 13](#).
 - Telnet or ssh connection to the group IP address.At the login prompt, enter the `grpadmin` account name and the password that you specified when creating the group.
2. At the Group Manager command prompt, use the following command to create the volume:

```
volume create volume_name size [GB]
```

Specify the volume name and size (the default unit of measure is megabytes).
3. Use the following command to create an access control record for the volume:

```
volume select volume_name access create access_control
```

The `access_control` parameter can be one or both of the following options:
 - `initiator initiator_name`

- `ipaddress ip_address`

You can create a maximum of 16 access control records for a volume.

The following example creates a 50GB volume and one access control record. Only a computer with the specified initiator name will be able to access the volume.

```
group1> volume create staff1 50GB
group1> volume select staff1 access create initiator iqn.1991-
05.com.microsoft:WIN2008Server.company.com
```

Using the GUI to Create a Volume

To provide storage space to end users, you create standard volumes that users can then access from host computers.

Before you create a standard volume, you need to understand:

- Volume attributes and groupwide default settings of the group apply to a volume.
- Volume security and access controls. In particular:
 - The conditions a computer must match to connect to the volume and its snapshots. Specify a CHAP user name, IP address, or iSCSI initiator name. This information generates an access control record that applies to the volume and its snapshots.
 - Permission for the volume, either read-write (default) or read-only.
 - Whether to allow or disallow (default) access to the volume and its snapshots by initiators with different iSCSI qualified names (IQNs).
- Risks and benefits associated with thin provisioning before applying this functionality to a volume.
- If creating the volume exceeds the capacity of the pool, free pool space has a negative value. Reduce the volume size.

If you enable thin provisioning, you can adjust the default settings for the thin-provisioned volume attributes, which are based on a percentage of the reported size.

To create a standard volume, use the Create Volume wizard described in the next section.

Create Volume Wizard

The Create Volume wizard guides you through the process of defining a new volume and setting the various options including name, size, pool assignment, sector size, snapshot space, iSCSI options, and access control options.

Step 1: Volume Settings

Field	Description	Shortcut Key
Name	(Required) A name that uniquely identifies the volume. Maximum length is 63 ASCII characters (including periods, hyphens, and colons).	Alt+A
Description	(Optional) Descriptive text about the volume's purpose or other distinguishing characteristics. Maximum length is 127 characters.	Alt+D

Field	Description	Shortcut Key
Create volume in folder	If the group has volume folders, check this checkbox and select a folder from the drop-down list to create the volume in this folder. Folders help you organize large collections of volumes into logical groups. Volumes can also be moved into folders after they are created.	Alt+F
Storage pool assignment	If the group has multiple storage pools, select the storage pool you want to create the volume in. Click the radio button next to the pool's name to select it. Unless otherwise specified, the default storage pool is used.	None

Step 2: Space

Field	Description	Shortcut Key
Volume size	A numeric value that specifies the size of the new volume. Select appropriate units (MB, GB, or TB) from the drop-down list. The minimum volume size is 1MB. The maximum volume size is given, based on the physical capacity of your storage pool.	Size: Alt+S Unit of measure: up and down arrow keys
Thin provisioned volume	Enables thin provisioning on the volume. Thin provisioning allocates space based on how much is actually used, but gives the impression the entire volume size is available. For example, a 100GB volume can be thin provisioned so only 20GB is physically allocated; the remaining 80GB becomes <i>Unreserved space</i> still available to the storage pool. Additional space can be allocated to the volume as necessary.	Alt+T
Snapshot reserve	Specifies how much additional space should be reserved to store snapshots of this volume. The default setting is 100% of the maximum volume size. At 100%, a 20GB volume would consume 40GB of storage space: 20GB for storage and 20GB for snapshots.	Alt+R
Reported Volume Size	<p>A graphic illustration of the space allocation on the volume. When thin provisioning is enabled, this illustration becomes a space allocating tool outfitted with 3 sliding pointer controls colored purple, yellow, and red, respectively. Click and drag the pointers to slide them back and forth.</p> <ul style="list-style-type: none"> Purple = Minimum Volume Reserve. Specifies, as a percentage of the volume size, how much usable space is allocated on the volume. Yellow = In-use warning limit. Generates a warning message when the specified percentage of the minimum volume reserve is consumed. For example, if the minimum volume reserve is 20GB and the warning limit is 80%, the warning message will occur when 16GB is consumed (or free space falls below 4GB). Red = Maximum in-use space. The maximum amount of space that can be allocated on the volume. This amount is 100% by default (the entire volume size) but can be reduced if desired. 	Spacebar opens a dialog box called Adjust marker values

Field	Description	Shortcut Key
Estimated changes in storage pool default	This table estimates how the currently proposed volume size and snapshot settings affect the existing space in the designated storage pool.	None

Step 3: Configure iSCSI Access

Field	Description	Shortcut Key
What kind of access type do you want for this volume?	Allows you to set the access controls for the volume. Select the radio button for the type of access you want: <ul style="list-style-type: none"> Copy access controls from another volume (Table 9) Select or define access control policies Define one or more basic access points None (do not allow access) 	<ul style="list-style-type: none"> Alt+P Alt+L Alt+I Alt+N
Do you want to allow simultaneous access to this volume from more than one iSCSI initiator?	Default is No. Select Yes to permit the volume to allow simultaneous access from initiators with different IQNs.	None

Table 9: Copy access controls from another volume

Field	Description	Shortcut Key
Select the volume from which to copy access controls	To apply an access control from another volume, select it with the mouse or the up and down arrows.	Alt+V
Access controls	Displays the properties of the access control for the selected volume. This information helps you choose which volume's access controls to copy to the new volume.	None

Table 10: Select or define access controls

Field	Description	Shortcut Key
Pick one or more access policies or policy groups	Shows the available access policies and policy groups to choose from. Select the radio button for Access Policies or Access Policy Groups to change the list. To use an existing policy or policy group, either double-click it, or select it in the Available list and click Add to move it into the Selected list. To use all the available policies and policy groups, click Add All.	Available list: Alt+A Add: Alt+A Add All: Alt+D Selected List: Alt+S Remove: Alt+R Remove All: Alt+M

Field	Description	Shortcut Key
New	Click New to define a new access policy or policy group.	None
Edit	From either the Available list or the Selected list, select an access policy or policy group and click Edit to change it.	None

Step 4: Sector Size

Field	Description	Shortcut Key
Sector Size	<p>You can create volumes that use either 512-byte or 4KB sectors. The sector size of a volume has no dependency on the sector size of the physical drives in the array. The default volume setting of 512 bytes is almost always optimal, even if the physical drives use 4KB sectors.</p> <p>If you create a volume that uses 4KB sectors, first verify that your operating system supports 4KB sectors. Refer to the documentation for your operating system for information about whether 4KB sectors are supported.</p> <p>After you have created a volume, you cannot change its sector size.</p>	<p>512 bytes: Alt+5</p> <p>4KB: Alt+4</p>

Step 5: Summary

This page lets you review the settings that will be applied to the new volume. Some of these are the settings you just specified in the wizard and others are set as defaults in the software.

Review these settings before you click `Finish` and create the volume.

Field	Description
General Settings	Displays the volume name, storage pool assignment, volume size, sector size, and description
Snapshot settings	Displays the amount of snapshot reserve space, and the current default settings regarding when to issue space warnings and how to manage space recovery
iSCSI Access	Displays the iSCSI settings for the volume including the access type and the access control rules that will be applied
Copy	Click this link to copy a text version of the summary settings to the computer's clipboard

- To make changes to the settings, use the `Back` button as necessary to return to previous screens.
- To create the volume with the current settings, click the `Finish` button.
- To close the dialog box without creating the volume, click `Cancel`.

Connect a Computer to a Volume

When you create a volume, the PS Series group automatically generates an iSCSI target name, with the volume name appended to the end of the target name. Each volume appears on the network as an iSCSI target.

An example of an iSCSI target name for a volume named `dbvol` is as follows:

```
iqn.2001-05.com.equallogic.5-4a0900-2f00000-007eca92d654f160-dbvol
```

To connect a computer to a volume:

1. Install and configure an iSCSI initiator on the computer. Hardware and software initiators are available from different vendors. Configure your initiator using the instructions provided by the vendor.

Note: Dell recommends that you visit the Technical Support website to obtain important information about using initiators to access PS Series group volumes.

2. Make sure that the computer matches one of the volume's access control records. To display the records for a volume:
 - Using the CLI, enter the following command:

```
volume select volume_name access show
```

- Using the GUI, expand `Volumes` in the far-left panel, select the volume name, and click the `Access` tab.

If necessary, use the CLI or the GUI to create an access control record that the computer will match.

3. To display the iSCSI target name for the volume:
 - Using the CLI, enter the following command:

```
volume select volume_name show
```

- Using the GUI, expand `Volumes` in the far-left panel, select the volume name, and click the `Connections` tab.

4. On the computer, use the iSCSI initiator utility to specify the group IP address as the iSCSI discovery address. If the initiator supports the discovery process, it will return a list of iSCSI targets that the computer can access.

If the initiator does not support discovery, you must also specify the target name and, in some cases, the standard iSCSI port number (3260).

5. Use the iSCSI initiator utility to select the desired target and log in to the target.

When the computer connects to the iSCSI target, it sees the volume as a regular disk that can be formatted using the normal operating system utilities. For example, you can partition the disk and create a file system.

6 Where to Go After Setting Up a Group

After setting up a group, you can customize the group in order to more effectively manage your storage environment. You can also begin to use the full set of product features. The following documentation and additional products are included in the purchase of your array and are available at any time.

- The *Hardware Owner's Manual* provides basic storage array information, maintenance information, and troubleshooting information for your PS Series storage array hardware.
- The *Dell EqualLogic Group Manager Administrator's Guide* provides details about configuring and using the PS Series firmware that is installed on each array. It includes information about storage concepts and how to use the Group Manager GUI to manage a group.
- The *Dell EqualLogic Group Manger CLI Reference Guide* describes how to use the Group Manager CLI to manage a group and individual arrays.
- The Manual Transfer Utility supports off-network replication of volume data.
- In a VMware® environment, you can use the Dell EqualLogic Virtual Storage Manager (VSM) for VMware to manage snapshots and replicas on the PS Series group that can restore individual virtual machines or the whole VMware environment.
- You can use the Dell EqualLogic Storage Replication Adapter for VMware Site Recovery Manager® (SRM), which allows SRM to understand and recognize PS Series replicas for full SRM integration.
- The Dell EqualLogic Multipathing Extension Module (MEM) provides enhancements to the VMware multipathing functionality.
- In a Microsoft environment, you can use the Auto-Snapshot Manager/Microsoft Edition to create and manage snapshots, clones, and replica Smart Copies on the PS Series group that can restore applications such as SQL Server, Exchange Server, Hyper-V, SharePoint, and NTFS file shares.
- If you have several PS Series groups, you can monitor and manage them with Dell EqualLogic SAN Headquarters.

Common Group Customization Tasks

[Table 11](#) describes common group customization tasks. These tasks are fully documented in the *Dell EqualLogic Group Manager Administrator's Guide*.

Table 11: Common Group Customization Tasks

Task	Description
Add network connections to a group member	Multiple network connections increase performance and availability and are required for multipath I/O. Dell recommends that you connect all the network interfaces on both control modules to multiple network switches and then use the GUI or CLI to assign an IP address and netmask to the interfaces and enable them.
Create administration accounts	The <code>grpadmin</code> account is the default administration account. Dell recommends that you set up additional accounts for each administrator, and reserve the default <code>grpadmin</code> account for maintenance operations

Task	Description
	such as firmware upgrades. Accounts can be configured to be authenticated through the PS Series group, RADIUS, or by using LDAP or Active Directory authentication.
Set up event notification	To be informed of significant events in a timely manner, set up email or syslog notification.
Configure SNMP	To monitor traps from the group, you can use SNMP. In addition, you need to configure SNMP to use the Manual Transfer Utility and other third-party monitoring tools.
Configure iSNS	To automate iSCSI target discovery, you can configure the group to use an iSNS server.
Configure CHAP accounts	You can use CHAP to restrict computer access to volumes. Both initiator and target CHAP authentication are supported.
Modify the date, time, or time zone or configure NTP	Group time is based on the clock on the first member, which is set at the factory. The default time zone is EST. You can also configure the group to use an NTP server.
Add a member to the group	Although a one-member group is fully functional, adding more arrays expands capacity, increases network bandwidth, and improves overall group performance, with no disruption to data availability.
Create pools	With multi-member groups, you can create multiple pools and assign members and volumes to the pools for a tiered storage solution.
Set up a dedicated management network	You can set up a separate management network for security purposes.
Create snapshots of a volume	Snapshots are point-in-time copies of volume data that can be used for backups.
Create schedules for snapshots or replicas	Schedules enable you to regularly create snapshots or replicas of a volume.
Create collections	Collections enable you to group multiple, related volumes for the purpose of creating snapshots or replicas. The administrator can then create a multi-volume snapshot or a multi-volume replica in a single operation or through a single schedule.
Enable thin provisioning for a volume	Some environments can benefit from thin provisioning, which enables you to allocate space to a volume according to usage patterns.
Set up replication across different groups	Replicas are point-in-time copies of volume data that are stored on a different group.
Clone a volume or snapshot	Cloning creates a new volume in the group.
Recover data from snapshots or replicas	There are various options for recovering data from snapshots or replicas.

7 Other Information You Might Need

See the safety and regulatory information that shipped with your system. Warranty information might be included within this document or as a separate document.

- The rack documentation included with your rack solution describes how to install your system into a rack.
- The Hardware Owner's Manual provides information about system features and describes how to troubleshoot the system and install or replace system components. This document is available online at eqlsupport.dell.com.

NOM Information (Mexico Only)

The information in this section is provided on the device described in this document in compliance with the requirements of the official Mexican standards (NOM):

AC Power Supply NOM Information for Mexico	
Importer	Dell México S.A. de C.V. Paseo de la Reforma 2620 - 11° Piso Col. Lomas Altas 11950 México, D.F.
Model number: E03J	Supply voltage: 100–240 VAC Frequency: 50/60 Hz Current consumption: 8.6A
Model number: E04J	Supply voltage: 100–240 VAC Frequency: 50/60 Hz Current consumption: 8.6A

Technical Specifications

Power Supplies	
Wattage	PS4210X, and XV (2.5-inch drives): <ul style="list-style-type: none"> • 700 W (max, total) • +5V up to 155W; +12V up to 624W; +5Vsb up to 10W PS4210XV (3.5-inch drives): <ul style="list-style-type: none"> • 1080W (max, total) • +5V up to 155W; +12V up to 924W; +5Vsb up to 10W
Voltage	AC Power Supply: 100-240 VAC (8.6 A-4.3 A)
Heat dissipation	PS4210X, XV (2.5-inch drives): 133-114W PS4210E (3.5-inch drives): 191-147W
Input frequency	Power Supply: 50/60 Hz
Max input power	990KVA PS4210X, XV (2.5-inch drives), S, XS: 990KVA PS4210E (3.5-inch drives): 1450KVA
Maximum inrush current	PS4210X and PS4210E with AC PSU :

Power Supplies	
	Under typical line conditions and over the entire system ambient operating range, the inrush current might reach 55A per power supply for 10 ms or less.

Physical	
Height	2U: 8.68 cm (3.41 inches) 8.68 cm (3.41 inches)
Width	44.63 cm (17.57 inches)
Depth	PS4210 E (3.5-inch drives): 57.5 cm (22.6 inches) PS4210 X, XV (2.5-inch drives) 54.1 cm (21.3 inches)
Weight (fully loaded array)	PS4210X, XV (2.5-inch drives), S, XS: 24.1 kg (53 lb) PS4210E (3.5-inch drives): 44.45 kg (98 lb)

Available Hard Drive Power (Per Slot)	
Supported hard drive power consumption (continuous)	For 2.5-inch drives: <ul style="list-style-type: none"> Up to 1.2 A at +5V Up to 0.5 A at +12V For 3.5-inch drives: <ul style="list-style-type: none"> Up to 1.16 A at +5V Up to 1.6 A at +12V

Environmental	
Operating temperature	5° to 50°C (41° to 104°F) with a maximum temperature gradation of 10°C per hour Note: For altitudes above 2950 feet, the maximum operating temperature is derated 1°F/550 ft.
Storage temperature	-40° to 65°C (-40° to 149°F) with a maximum temperature gradation of 20°C per hour
Operating relative humidity	20% to 80% (noncondensing) with a maximum humidity gradation of 10% per hour
Storage relative humidity	5% to 95% (noncondensing)
Operating vibration	0.26 Grms (5 to 350 Hz) for 5 minutes in operational orientations only
Storage vibration	1.88 Grms (10 to 500 Hz) for 15 minutes (all 6 sides)
Storage shock	PS4210X, XV (2.5-inch drives): PS4210E (3.5-inch drives): <ul style="list-style-type: none"> Half-sine shock 71G +/- 5% with a pulse duration of 2 ms +/- 10% (all 6 sides) Square wave shock 22G with a velocity change of 200 in/sec (all 6 sides)
Operating altitude	-16 to 3048 m (-50 to 10,000 ft) Note: For altitudes above 2950 feet, the maximum operating temperature is derated 17.22222°C (1°F)/550 ft.
Storage altitude	-16 to 10,600 m (-50 to 35,000 ft)
Airborne contaminant	Class G2 or lower as defined by ISA-S71.04-1985

Environmental	
level	
Acoustics	<ul style="list-style-type: none">• Active mode: 7.4 bels, A-Weighted sound power level, LwA-UL as measured per ISO 7779 and declared per ISO 9296

Index

A

- access control records**
 - creating 24
- access controls**
 - setting up with CLI 23
- accounts**
 - configuring after setup 29
- array**
 - choosing where to mount 6
 - initializing 17
 - mounting in rack 6
 - network address 17
 - RAID policy 21
 - software configuration 17

B

- battery**
 - charging time 13
- bezel**
 - installing 8

C

- cables**
 - 10GB copper 9
 - 10GB, optical 9
 - Ethernet 5
- CHAP accounts**
 - configuring 30
- CLI**
 - creating volumes 23
 - setting RAID policy 21
- control modules** 13
- copper cables** 9

D

- date**
 - setting 30

E

- electrostatic discharge** 4
- electrostatic wrist strap** 4
- environmental requirements** 4
- event notification**
 - configuring 30

G

- Gigabit Ethernet recommendation** 9
- group**
 - accessing volumes from a computer 28
 - advanced tasks 29
 - creating 17
 - customizing after setup 29
 - expanding 17
 - IP address 18
 - logging in to CLI 21
 - logging in to GUI 21
 - name 18
- GUI**
 - setting RAID policy 21

H

- hardware**
 - requirements 5
 - supplied 5
- Host Integration Tools**
 - description 20

I

- initiator (iSCSI)**
 - accessing a volume 28
 - computer requirements 28
- installation safety precautions** 3
- installing**
 - front bezel 8
- iSNS**
 - configuring 30

L

- login**
 - CLI method 21
 - GUI method 21

M

- management network switch** 5
- member**
 - default gateway 17
 - naming 17
 - netmask 17
 - network address 17
 - RAID policy 21

N

- netmask**
 - member setting 17
- network**
 - array IP address 17
 - configuring multiple interfaces 29
 - group IP address 18
 - improving performance 9
 - recommendations 9
 - requirements 9
- network cables** 12
- network interfaces**
 - configuring 17
- NTP server**
 - configuring 30

O

- optical cables** 9
- optional hardware** 6

P

- power**
 - turning on 12
- power requirements** 4
- PS Series array**
 - increasing bandwidth 9
 - network recommendations 9
 - network requirements 9
 - protecting from discharge 4
 - subnet access recommendation 10

R

- rack mount**
 - choosing rail location 6
 - inserting chassis 6
 - installing chassis 6
 - requirements 3
- RAID levels**
 - supported 21
- RAID policy**
 - description 21
 - setting with CLI 21
 - setting with GUI 21
- Remote Setup Wizard**
 - configuring the software 20

S

- safety precautions**
 - installation 3
- serial cable**
 - characteristics 15
 - connecting 13
 - pin locations 15
 - pinout information 15
- setup utility**
 - configuring the software 19
 - description 17
 - requirements 17
- shipping box contents** 5
- snapshots**
 - reserving space 23
- SNMP**
 - configuring 30
- software configuration**
 - methods 17
- Spanning Tree recommendation** 10
- supplied hardware** 5
- switch**
 - for management only 5
- switches**
 - 10/100Mbps 5
 - bandwidth requirement 10
 - link recommendation 10
 - Spanning-Tree recommendation 10
 - VLAN recommendation 10

T

- target (iSCSI)**
 - connecting to 28
 - obtaining name 28
- technical specifications** 4
- thin provisioning**
 - enabling on a volume 23
- time, setting** 30

V

- VLAN recommendation** 10
- volumes**
 - access control records
 - creating 24
 - access controls 24
 - accessing from a computer 28
 - connecting to 27
 - creating 23
 - creating standard 24
 - creating with CLI 23

naming [23](#)
reported size [23](#)
snapshot space [23](#)
target name for [28](#)
thin provisioning settings [23](#)

W

warranty [31](#)

Printed in <INSERT COUNTRY NAME HERE>

<TRANSLATION LINE 1>

<TRANSLATION LINE 2>

<TRANSLATION LINE 3>

<TRANSLATION LINE 4>

<TRANSLATION LINE 5>

<TRANSLATION LINE 6>

<TRANSLATION LINE 7>

<TRANSLATION LINE 8>

www.dell.com | support.dell.com



M40C6A00