



PS4000 STORAGE ARRAYS

Hardware Maintenance

Copyright 2009 Dell, Inc. All rights reserved.

Dell is a trademark of Dell, Inc.

EqualLogic is a registered trademark.

All trademarks and registered trademarks mentioned herein are the property of their respective owners.

Information in this document is subject to change without notice.

Reproduction in any manner whatsoever without the written permission of Dell is strictly forbidden.

April 2009

Part Number: 110-6020-R1

Table of Contents

Preface	v
Audience	v
Organization	v
Documentation	vi
Technical Support and Customer Service	vii
Warranty Information	viii
1 Basic Storage Array Information.....	1-1
Array Front and Back Panels.....	1-1
Interpreting Operations Panel LEDs	1-2
Using an Electrostatic Wrist Strap	1-5
Shutting Down and Restarting an Array	1-5
2 Maintaining Disk Drives	2-1
Removing the Bezel	2-1
Interpreting Disk Drive LEDs	2-3
Disk Drive Handling Requirements	2-4
Identifying Failed Disk Drives	2-4
Array Behavior When a Disk Drive Fails	2-5
Removing Disk Drives	2-5
Disk Drive Installation Guidelines and Restrictions	2-7
Installing Disk Drives.....	2-7
Installing the Bezel.....	2-8
3 Maintaining Control Modules	3-1
Control Modules.....	3-1
Interpreting Control Module LEDs	3-2
Identifying Control Module Failures.....	3-3
Understanding Failover Behavior	3-3
Maintaining Control Module Firmware	3-4
Network Configuration Recommendations.....	3-5
Connecting Network Cables.....	3-6
Control Module Handling Requirements	3-9
Removing a Control Module	3-9
Installing a Control Module	3-13
Replacing the Firmware Card.....	3-15
Replacing a Compact Flash Card	3-16

Replacing a Micro SD Card.....	3-18
4 Maintaining Power Supply Modules.....	4-1
Interpreting the LEDs.....	4-1
Identifying Failures	4-1
Removing a Power Supply and Cooling Module.....	4-2
Installing a Power Supply and Cooling Module	4-4
A Environmental, Power, and Other Specifications.....	A-1
Index.....	Index-1

Preface

This manual describes how to maintain the hardware for PS4000 storage arrays. Each array contains hot-swappable power supply and cooling modules, eight or sixteen RAID-protected disks, and single or dual hot-swappable control modules.

With one or more PS Series arrays, you can create a PS Series group—a self-managing, iSCSI storage area network (SAN) that is affordable and easy to use, regardless of scale.

Audience

This manual is designed for the administrators responsible for maintaining PS4000 hardware. Administrators are *not* required to have extensive network or storage system experience. However, it may be useful to understand:

- Basic networking concepts
- Current network environment
- User disk storage requirements
- RAID configurations
- Disk storage management

Note: Although this manual provides examples of using PS Series arrays in some common network configurations, detailed information about setting up a network is beyond its scope.

Organization

This manual is organized as follows:

- Chapter 1, *Basic Storage Array Information*, describes the array front and back panels, how to interpret LEDs, how to use an electrostatic wrist strap, and how to shut down and restart an array.
- Chapter 2, *Maintaining Disk Drives*, describes how to install and remove disks.
- Chapter 3, *Maintaining Control Modules*, describes how to install and maintain control modules. It also describes the best way to connect network cables to control modules for high performance and availability.

- Chapter 4, *Maintaining Power Supply Modules*, describes how to install and remove the modules that provide power and cooling to the array.
- Appendix A, *Environmental, Power, and Other Specifications*, describes the specifications for a PS4000 array.

Documentation

For detailed information about PS Series arrays, groups, and volumes, see the following documentation:

- PS Series *Release Notes*. Provides the latest information about PS Series arrays.
- Dell EqualLogic *PS Series Array End User License Agreement (EULA)*
- *Warranty and Support Information (WSI)*
- *Safety, Environmental, and Regulatory Information (SERI)*
- PS Series *Installation and Setup*. Describes how to set up the array hardware and create a PS Series group. The *Installation and Setup* manual is printed and shipped with the product. Use the manual specific to your array model.
- PS Series *Group Administration*. Describes how to use the Group Manager graphical user interface (GUI) to manage a PS Series group. This manual provides comprehensive information about product concepts and procedures.
- PS Series *CLI Reference*. Describes how to use the Group Manager command line interface (CLI) to manage a PS Series group and individual arrays.
- PS Series Online help. In the Group Manager GUI, expand `TOOLS` in the far left panel and then click `Online Help` for help on both the GUI and the CLI.

Documentation for Host Integration Tools for Microsoft® Windows® includes the following:

- Host Integration Tools *Release Notes*. Provides the latest information about the Host Integration Tools, including the Remote Setup Wizard.
- Host Integration Tools *User Guide*. Describes how to install and use the Host Integration Tools.

See support.dell.com/EqualLogic for the latest documentation.

Technical Support and Customer Service

Dell's support service is available to answer your questions about PS Series arrays. If you have an Express Service Code, have it ready when you call. The code helps Dell's automated-support telephone system direct your call more efficiently.

Contacting Dell

Dell provides several online and telephone-based support and service options. Availability varies by country and product, and some services may not be available in your area.

For customers in the United States, call 800-945-3355.

Note: If you do not have an Internet connection, you can find contact information on your purchase invoice, packing slip, bill, or Dell product catalog.

To contact Dell for sales, technical support, or customer service issues:

1. Visit `support.dell.com`.
2. Verify your country or region in the Choose A Country/Region drop-down menu at the bottom of the window.
3. Click `Contact Us` on the left side of the window.
4. Select the appropriate service or support link based on your need.
5. Choose the method of contacting Dell that is convenient for you.

Online Services

You can learn about Dell products and services on the following websites:

- `www.dell.com/`
- `www.dell.com/ap/` (Asian/Pacific countries only)
- `www.dell.com/jp` (Japan only)
- `www.euro.dell.com` (Europe only)

- www.dell.com/la (Latin American countries)
- www.dell.ca (Canada only)

You can access Dell Support through the following websites:

- support.dell.com
- support.dell.com/EqualLogic
- support.jp.dell.com (Japan only)
- support.euro.dell.com (Europe only)

Warranty Information

The PS4000 array warranty is included in the shipping box. For information about registering a warranty, visit support.dell.com/EqualLogic.

1 Basic Storage Array Information

This chapter includes basic information about PS4000 storage arrays.

Array Front and Back Panels

The front of a PS4000 array is shown in Figure 1-1 and Figure 1-2.

Figure 1-1: PS4000 Front Panel (with Bezel)



Figure 1-2: PS4000 Front Panel (without Bezel)

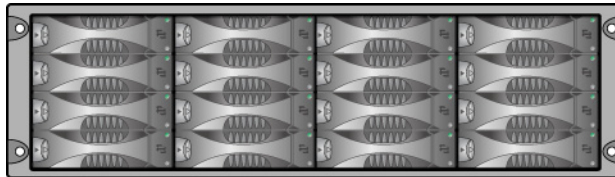

The disk drives are accessible from the front, after you remove the bezel. See Chapter 2 for detailed information about disk drives.

The components on the back of a PS4000 (with Type 8 control modules) are shown in Figure 1-3 and described in Table 1-1.

Note: The figures in this manual show the Type 8 control modules. Unless otherwise noted, the information in this manual applies to both the Type 8 and Type 9 control modules.

Figure 1-3: PS4000 Back Panel

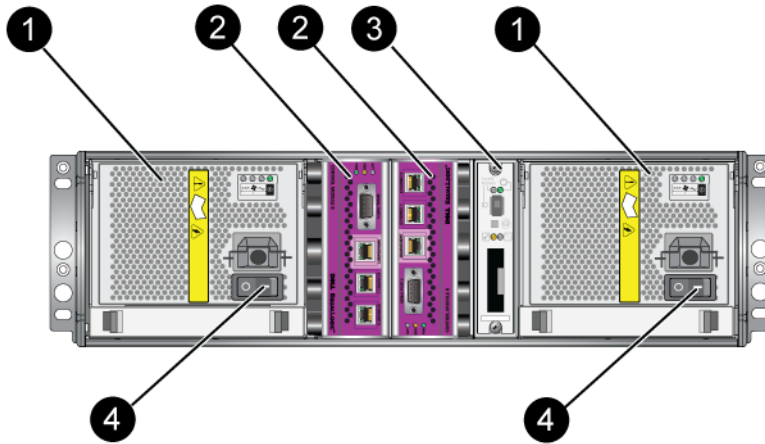

Table 1-1: Back Panel Detail Description

Item	Description
1	Power supply and cooling modules. The module on the right is 0, and the module on the left is 1.
2	Control modules. The module on the right is 0, and the module on the left is 1.
3	Operation panel LED. Includes LEDs that show the status of the array (error and warning conditions), power status, and location.
4	Power switches on the power supply and cooling modules. Turns power on and off to the array.

Interpreting Operations Panel LEDs

The operations panel monitors array hardware components. The panel is not redundant, but an array can continue to operate if it fails. See your array support provider for information about servicing the operations panel.

Figure 1-4 shows the operations panel LEDs, which can alert you to errors and conditions that require your attention. Table 1-2 describes the LEDs. Report any serious problems to your array support provider.

Note: The serial number for your array is on a label on the operations panel.

For information about other array LEDs, see *Interpreting Disk Drive LEDs* on page 2-3, *Interpreting Control Module LEDs* on page 3-2, and *Interpreting the LEDs* on page 4-1.

Figure 1-4: Operations Panel

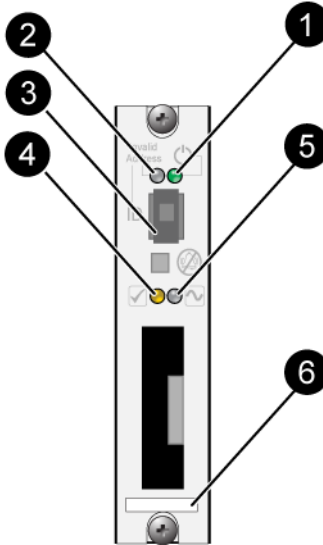

Table 1-2: Operations Panel Descriptions

Item	Status	Description
1 Power LED	Off	No power.
	Green	Power.
2 Array locator LED	Off	No power or normal condition.
	Flashing orange	Administrator enabled the array locator function.
3 Identifier switch	N/A	Not used.

Table 1-2: Operations Panel Descriptions (Continued)

Item	Status	Description
4 Warning condition LED	Off	No power or normal condition.
	Flashing orange	One or more of the following has occurred: <ul style="list-style-type: none"> • RAID set is degraded but still functioning. • RAID set (volume level) has lost blocks. • Component temperature is near a limit. • Fan failed or fan RPMs exceed limit. • Power supply is not installed or has no power. • Cache battery has less than 72 hours of charge. • Only one control module installed or control module has failed over. • Control module has insufficient RAM. • Syncing active and secondary control modules. • No communication between control modules. • Installed spare disk drive does not have enough capacity to replace a disk drive in a RAID set. • A non-critical hardware component failed. • Real-time clock battery is low.
5 Critical error condition LED	Off	No power or normal condition.
	Flashing orange	One or more of the following has occurred: <ul style="list-style-type: none"> • RAID is not functioning. • Lost block table is full. • Temperature exceeds upper or lower limit. • Control module cache has lost data. • A cooling module is not installed. • Both fans on a cooling module have failed. • Cache battery temperature is too high to charge battery. • NVRAM coin cell battery failed. • Cache contains data that does not belong to any of the installed disk drives. • More than one valid RAID set exists in array. • Control modules are different models. • A critical hardware component has failed. • Operations panel failed or not installed. • Storage enclosure processor that monitors array components has experienced a failure.

Table 1-2: Operations Panel Descriptions (Continued)

Item	Status	Description
6 Serial number label	N/A	This label contains the serial number for your array. If you contact your PS Series support provider, you may need to provide this number.

Using an Electrostatic Wrist Strap

When handling the array chassis, disk drives, or control modules, you must use an electrostatic protection device to prevent electrostatic discharge.

An electrostatic wrist strap is included in the shipping box. See Figure 1-5.

Figure 1-5: Electrostatic Wrist Strap

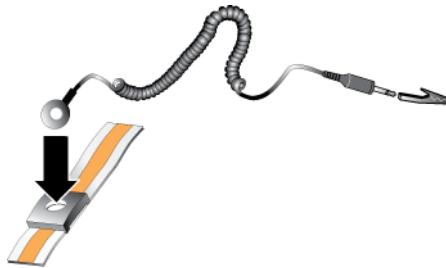

Shutting Down and Restarting an Array

A PS4000 array includes redundant, hot-swappable disk drives, power supplies, and control modules (in a dual control module array). You can remove a redundant component without affecting operation if a functioning component is available. Otherwise, it is recommended that you *cleanly* shut down the array and turn off power before removing a component.

Note: When an array is shut down, any volumes with data on the array will be set offline until the array is successfully restarted. This may affect initiators that are connected to the volumes.

1. Do one of the following:
 - Use telnet or SSH to connect to a functioning IP address assigned to a network interface on the array. Do not connect to the group IP address.

- Use the null modem cable shipped with the array to connect to Serial Port 0 on the active control module (ACT LED is green) to a console or a computer running a terminal emulator.

Make sure the serial line characteristics are as follows:

- 9600 baud
 - One STOP bit
 - No parity
 - 8 data bits
 - No flow control
2. Log in to an account with read-write access, such as the `grpadmin` account.
 3. Enter the `shutdown` command, as shown next.

```
login: grpadmin
Password:

                Welcome to Group Manager

                Copyright 2001-2009 Dell, Inc.

group1> shutdown
```

If you are using a serial connection to shut down an array, it is safe to turn off power when the “press any key” message appears. (Pressing any key will restart both control modules.)

If you are using a network connection, the session will be disconnected before the array is fully shut down. Confirm that the CACT LED on each control module is off (not lit) before turning off power to the array.

After performing array maintenance, you can turn on power to the array. When the array restart completes, the member and volumes will be set online.

2 Maintaining Disk Drives

The array includes up to 16 hot-swappable disk drives, either Serial Attached SCSI (SAS) or Serial ATA (SATA). Disk drive maintenance topics apply to both SAS and SATA disk drives.

Removing the Bezel

To access the disk drives, you must remove the bezel.

The bezel comes with a lock, which helps protect the disk drives from being tampered with or accidentally removed.

To unlock and remove the bezel:

1. Insert the bezel key and turn it clockwise to unlock the bezel. See Figure 2-1.

Figure 2-1: Unlocking the Bezel

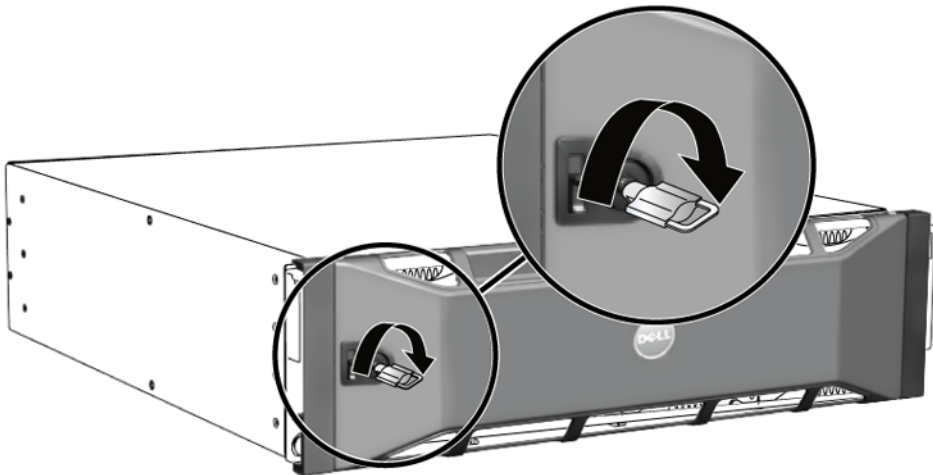

2. Push the bezel release latch up to disengage the bezel from the chassis. See Figure 2-2.

Figure 2-2: Pushing Up the Bezel Release Latch

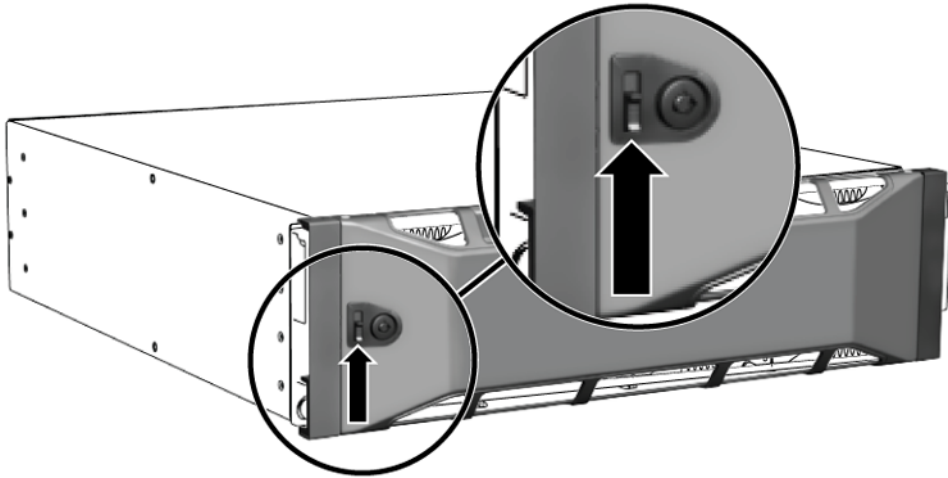

3. Hold the bezel and pull it away from the chassis. See Figure 2-3.

Figure 2-3: Detaching the Bezel from the Chassis

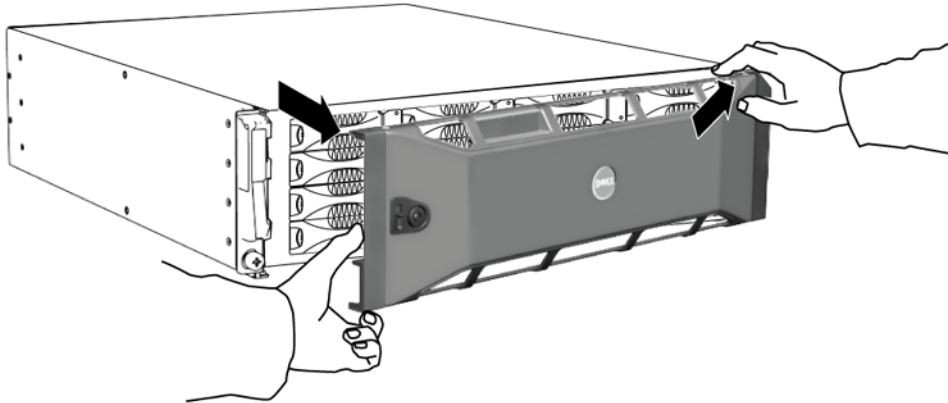

Interpreting Disk Drive LEDs

Figure 2-4 shows how disk drives are oriented and numbered in the array.

Figure 2-4: Disk Drive Numbering

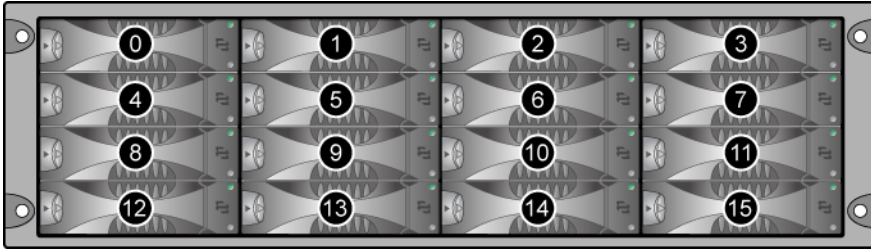

The parts of a disk drive are shown in Figure 2-5 and described in Table 2-1.

Figure 2-5: Disk Drive Detail

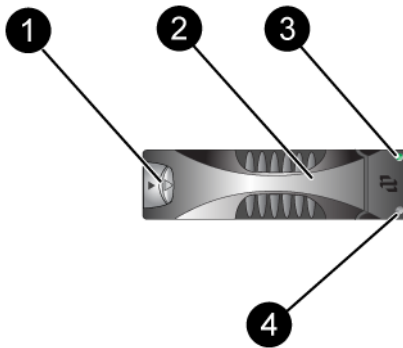

Table 2-1: Disk Drive Detail Descriptions

Callout	Item	Color	Description
1	Disk drive handle release button	Black	SAS disk drive.
		Gray	SATA disk drive.
2	Handle	Gray	Same for SAS and SATA disk drives.
3	Power and disk drive activity LED	Off	No power or an error condition.
		Green	Power.
		Flashing green	Disk drive activity.

Table 2-1: Disk Drive Detail Descriptions (Continued)

Callout	Item	Color	Description
4	Error LED	Off	No power or normal condition.
		Red	Error condition.

Disk Drive Handling Requirements

Handle disk drives as follows:

- **Store drives properly.** Store replacement disk drives in the packaging in which they were shipped. Do not stack disk drives or place anything on top of a disk drive.
- **Protect disk drives from electrostatic discharge.** Wear an electrostatic wrist strap when handling a disk drive, unless it is protected from electrostatic discharge.
- **Handle disk drives carefully.** Hold a disk drive only by the plastic part of the carrier or the handle. Do not drop or jolt a disk drive or force a disk drive into a slot.
- **Warm replacement disk drives to room temperature before installation.** For example, let a disk drive sit overnight before installing it in an array.
- **Do not leave disk drive slots empty.** Each disk drive slot in an array must contain a disk drive assembly or a blank carrier. Operating an array with an empty slot will void your warranty and support contract.
- **Do not remove a disk drive from its carrier.** This action will void your warranty and support contract.
- **Keep the shipping material.** Return a failed disk drive to your array support provider in the packaging in which the replacement disk drive was shipped. Shipping disk drives in unauthorized packaging may void your warranty.

Identifying Failed Disk Drives

A disk drive failure is indicated by:

- LEDs on the disk drive. See *Interpreting Disk Drive LEDs* on page 2-3.
- A message on the console, in the event log, or in the Group Manager GUI Alarms panel describes a disk drive failure.

- The GUI Member Disks window or the CLI `member select show disks` command shows a disk drive failure.

Array Behavior When a Disk Drive Fails

How an array handles a disk drive failure depends on whether a spare disk drive is available and whether the RAIDset containing the failed disk drive is degraded.

For example:

- If a spare disk drive is available, it replaces the failed disk drive. Performance is normal after reconstruction completes.
- If a spare disk drive is not available and the failed disk drive is in a RAIDset with no previous disk drive failure, the RAIDset can become degraded. Performance may be impaired.
- If a spare disk drive is not available and the failed disk drive is in a RAIDset that is already degraded, data may be lost and must be recovered from a backup.
- If a disk drive fails, do not remove and re-install it in the array. It must be replaced.

Removing Disk Drives



Caution: Wear electrostatic protection when handling a disk drive. See *Using an Electrostatic Wrist Strap* on page 1-5.

Notes: Replace a failed disk drive as soon as possible to provide the highest availability.

Do not remove a disk drive from a slot, unless you have another disk drive or a blank carrier to replace it. Each slot *must* contain a disk drive or blank carrier.

Do not remove a functioning disk drive from an array, unless the disk drive is a spare; otherwise, a RAIDset may become degraded. If you remove a spare, replace the disk drive as soon as possible.

Before completely removing a functioning disk drive from an array slot, wait 30 seconds to allow the disk drive to stop spinning and the heads to land.

Store replacement disk drives in the packaging in which they were shipped.

To remove a disk drive:

1. Press the handle release button to the left, in the direction of the arrow, to disengage the handle.
2. Grasp the handle and pull the disk drive 2.5 cm (1 inch) from the slot. See Figure 2-6.

Figure 2-6: Removing a Disk Drive

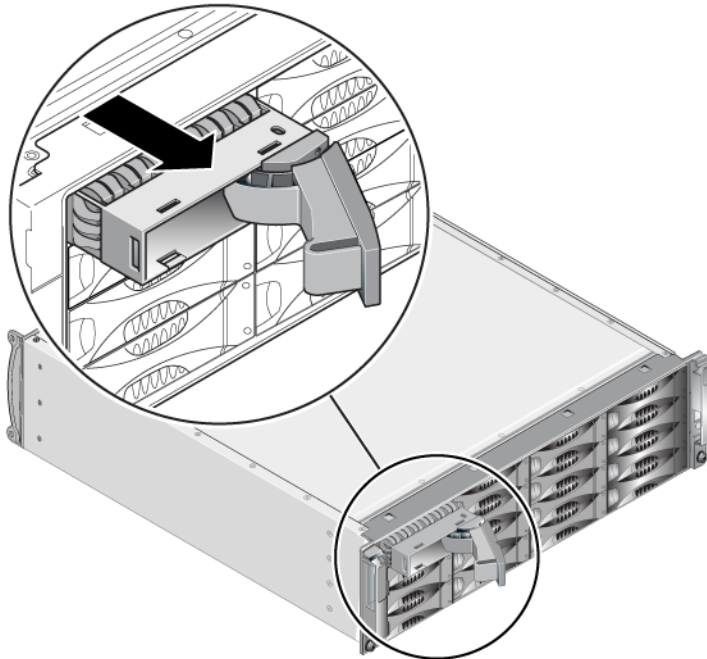

3. Wait 30 seconds to allow the heads to land. (Does not apply when removing a blank carrier.)
4. Pull the disk drive further from the slot and re-engage the handle. You will hear a click. Then, pull the disk drive completely out of the array.

Disk Drive Installation Guidelines and Restrictions

- Install only disk drives of the same type, speed, and spin rate in an array. The color of the handle release button indicates the disk drive type (black for SAS; gray for SATA).
- Make sure the disk drive is oriented in the position shown in Figure 2-4, with the handle release button to the left.
- You can use disk drives with different sizes in an array. However, the smallest disk drive in the array will determine how much space can be used on each disk drive. For example, if the smallest disk drive is 400GB, only 400GB of space will be available for use on each disk drive.
- Make sure to insert a disk drive fully in the chassis before pushing in the handle.
- When correctly installed, a disk drive will be level with the front of the array. If the disk drive is protruding from the array, reinstall the disk drive.
- After installation, make sure the disk drive power LED (top) is green or flashing green.
- There is a two-minute delay between the time you insert a disk drive and the time the disk drive is automatically configured into a RAIDset. This time interval allows multiple disk drives to be simultaneously configured in an array, which is more efficient than installing a single disk drive, configuring it, and then repeating the process. For example, when you install a disk drive, the timer starts. If no other disk drives are installed, the disk drive is configured after a delay of two minutes. If you install another disk drive before two minutes have elapsed, the timer is restarted.
- If you install a disk drive during RAID reconstruction or verification, the new disk drive will not be configured until the operation completes.

Installing Disk Drives



Caution: Wear electrostatic protection when handling a disk drive. See *Using an Electrostatic Wrist Strap* on page 1-5.

To install a disk drive or a blank carrier:

1. Hold the disk drive by the plastic carrier, with the handle release button to the left, and slide the disk drive partially into a slot.

2. Press the handle release button to release the handle. Open the handle.
3. With the handle at an angle, slide the disk drive completely into the slot, simultaneously pushing in the handle until you hear a click. See Figure 2-7.

Figure 2-7: Closing the Disk Drive Handle

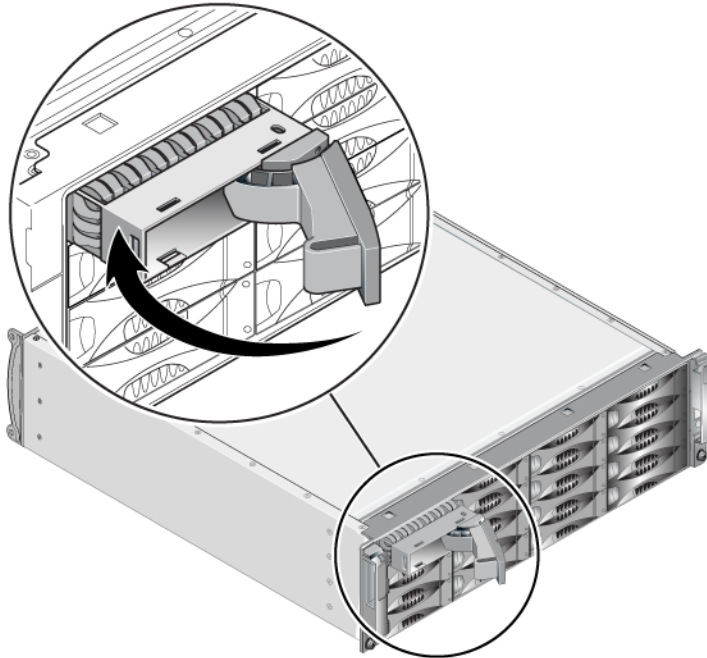

Verify that the new disk drive is operational by examining the LEDs on the front panel, as described in *Interpreting Disk Drive LEDs* on page 2-3. In addition, examine the GUI Member Disks window and the CLI `member select show disks` command output.

Installing the Bezel

After you install all the replacement disk drives or blanks, re-install and lock the bezel.

1. Facing the front of the array, fit the right side of the bezel into the right side of the chassis.

2. Push the bezel toward the chassis until the left side of the bezel engages with the chassis.
3. Insert the bezel key and turn it counter-clockwise to lock the bezel.
4. Store the key in a safe place.

3 Maintaining Control Modules

A PS4000 array includes one or two hot-swappable control modules. One functioning control module is required for array operation. You access control modules from the rear of the array.

Control Modules

A PS4000 array includes either two Type 8 or two Type 9 control modules. See Figure 3-1 and Figure 3-2.

Figure 3-1: Type 8 Control Module

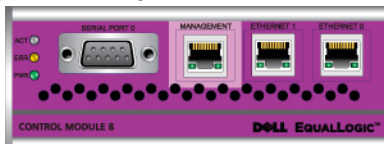
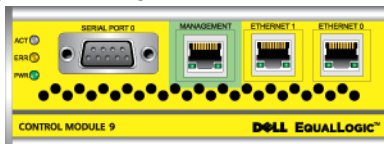

Figure 3-2: Type 9 Control Module



Each control module includes:

- Two Gigabit iSCSI Ethernet ports for iSCSI or management traffic
- One 10Mb/100Mb management port (for use only if you configure a management network)
- One serial connector (for use if there is no network access to the array)
- A firmware card running the PS Series firmware. In a Type 8, it is a compact flash card. In a Type 9, it is a micro SD card.

Cache and NVRAM batteries are not field replaceable. For information about replacing a cache or NVRAM battery, contact your PS Series service provider.

Only one control module is active (serving network traffic) at one time. The secondary (redundant) control module mirrors cache data from the active control

module. If the active control module fails, the secondary will take over network operations.

Do *not* mix control module types in an array. Always make sure both control modules are the same type and color. See the latest PS Series *Release Notes* for information about other supported control modules.

Interpreting Control Module LEDs

Control modules have the following LEDs:

- On the left side of each control module, three LEDs enable you to determine the control module status and whether the control module is active or secondary. See Figure 3-1 and Figure 3-2.
- Each Ethernet port has two LEDs that show the network interface status. See Figure 3-1 and Figure 3-2.

Control module LEDs are described in Table 3-1. Ethernet port LEDs are described in Table 3-2.

Table 3-1: Control Module LED Descriptions

LED Location	Color	Description
ACT LED	Off	No power, secondary control module is not synchronized with active control module, or error condition.
	Green	Active control module (serving network I/O).
	Orange	Secondary control module. Cache is synchronized with active control module.
ERR LED	Off	Normal operation or no power.
	Red	Array is starting up or error condition.
PWR LED	Off	No power.
	Green	Power.

Table 3-2: Ethernet Port LED Descriptions

LED Location	Color	Description
Left side of each port	Off	No power or not connected to network.
	Green	Connected to network.
Right side of each port	Off	No power, not transmitting, or not receiving.
	Green	Transmitting or receiving.

Identifying Control Module Failures

You can identify a failure in a control module by:

- **LEDs.** See *Interpreting Control Module LEDs* on page 3-2.
- **Messages.** A message on the LCD panel (located behind the bezel), on the console, in the event log, or in the Group Manager GUI Alarms panel describes a control module failure.
- **Group Manager GUI and CLI output.** The Member Controllers window or the `member select show controllers` command output shows the control module status `not installed`.

When viewed from the rear of the array, CM0 is on the right, and CM1 is on the left. See Figure 1-3.

If a control module fails, see your PS Series support provider for a replacement.

Understanding Failover Behavior

In a dual control module array, only one control module is active (serving network traffic) at one time. Each control module includes a battery-backed write cache for storing recently-used data. For redundancy, the cache on the secondary control module mirrors the data that is stored in the cache on the active control module.

The active control module can use a network interface only if there is a cable connected to the port on the active control module. Therefore, you should connect a cable to a network interface port on each control module to make sure that both control modules can access an interface.

A PS series array provides two types of network failure protection:

- **Network connection failover.** If multiple network interfaces are configured and one network interface fails, iSCSI initiators that were connected to the failed interface can reconnect to the group IP address and be redirected to a functioning interface. For example, in a single control module array, if Ethernet 0 and Ethernet 1 are connected to a network, and Ethernet 0 fails, initiators that were connected to Ethernet 0 can be redirected to Ethernet 1.
- **Control module failover.** In a dual control module array, if the active control module fails, the secondary automatically takes over and becomes active. If a cable is connected to the port on the newly active control module, network I/O can continue through that interface. Control module failover is transparent to applications, but iSCSI initiators must reconnect to the group IP address.

Maintaining Control Module Firmware

A Type 8 control module has a compact flash card, and a Type 9 control module has a micro SD card, running the array firmware. You should run the latest firmware version to take advantage of new product features and enhancements.

Caution: In a dual control module array, both control modules must be running the same firmware version; otherwise, only one control module will be functional. When you use the update command procedure, both control modules are updated to the same firmware version.

Group members should run the same firmware version; otherwise, only the functionality common to all versions will be available in the group. See the PS Series *Release Notes* for information about mixed-firmware groups.

If you are adding a second control module, upgrading a control module, or replacing a failed compact flash or micro SD card, make sure to order the correct PS Series firmware version. If you are replacing a failed control module, remove the compact flash or micro SD card from the failed control module and install it in the replacement control module. This will make sure that you keep the correct firmware.

To display the firmware version running on an array, examine the GUI Member Controllers window or use the CLI `member select show controllers` command. If the firmware on a micro SD card does not match the firmware running on an array, do not install it. Instead, contact your array support provider.

Network Configuration Recommendations

Dell recommends that you follow the guidelines in Table 3-3. In addition, all the usual rules for proper network configuration apply to group members. General network configuration is beyond the scope of this manual.

Table 3-3: Network Recommendations

Recommendation	Description
Switched Gigabit Ethernet network	Connect arrays and hosts to a switched network and make sure that all network connections between hosts and arrays are Gigabit Ethernet. Although an array can operate at 10 or 100 Mbits, performance will be slower than when using a Gigabit Ethernet switch.
Multiple network connections	<p>For increased bandwidth and availability, connect Ethernet 0 and Ethernet 1 on both control modules to multiple network switches.</p> <p>The switches must be connected using interswitch links. The links must have sufficient bandwidth to handle the iSCSI traffic.</p> <p>After connecting the network interfaces, use the Group Manager GUI or CLI to assign an IP address and netmask to each interface.</p>
Access to the group IP address	In a multi-subnet group, each configured network interface should have access to the subnet on which the group IP address resides.
Redundant network paths	Using a multipathing solution helps to make sure that no single point of failure exists between computers and arrays.
For replication, a reliable, adequately sized network link	For effective and predictable replication, make sure that the network link between the primary and secondary groups is reliable and provides sufficient bandwidth for copying data.

Table 3-3: Network Recommendations (Continued)

Recommendation	Description
No STP functionality on switch ports that connect end nodes	<p>If possible, do not use Spanning-Tree (STP) on switch ports that connect end nodes (iSCSI initiators or storage array network interfaces).</p> <p>However, if you must use STP or RSTP (preferable to STP), you should enable the port settings (available on some switches) that let the port immediately transition into STP forwarding state upon link up. This functionality can reduce network interruptions that occur when devices restart, and should only be enabled on switch ports that connect end nodes.</p> <p>You can use Spanning-Tree for a single-cable connection between switches, or trunking for multi-cable connections between switches.</p>
Flow Control enabled on switches and NICs	Enable Flow Control on each switch port and NIC that handles iSCSI traffic. PS Series arrays will correctly respond to Flow Control.
Unicast storm control disabled on switches	Disable unicast storm control on each switch that handles iSCSI traffic, if the switch provides this feature. However, the use of broadcast and multicast storm control is encouraged on switches.
Jumbo Frames enabled	Enable Jumbo Frames on each switch and NIC that handles iSCSI traffic.
VLANs	Configure switches to use VLANs to separate iSCSI SAN traffic from other network traffic.

Connecting Network Cables

A PS4000 array must have at least one active network connection. Multiple network connections are recommended for performance and availability.

Connect cables to network interfaces as follows:

- For copper-based networks, use Category 5E or Category 6 cables with RJ45 connectors. Use Category 5 cables if they meet the TIA/EIA TSB95 standard.
- Connect the interfaces in numeric order, always starting with Ethernet 0.
- Connect the interfaces to different network switches.
- In a dual control module array, to ensure connectivity if one control module fails, connect a cable to the interface port on each control module. For example, connect a cable to Ethernet 0 on CM0 and to Ethernet 0 on CM1, and then connect the cables to a network switch.

For a single control module array, the minimum network configuration is one network connection to Ethernet 0. However, the single network connection is a potential point of failure and limits bandwidth. Dell recommends that you connect Ethernet 0 and Ethernet 1 to different network switches.

For example, if you connect cables as shown in Figure 3-3, and Ethernet 0 fails, initiators can be redirected to Ethernet 1.

Figure 3-3: Recommended Single Control Module Configuration

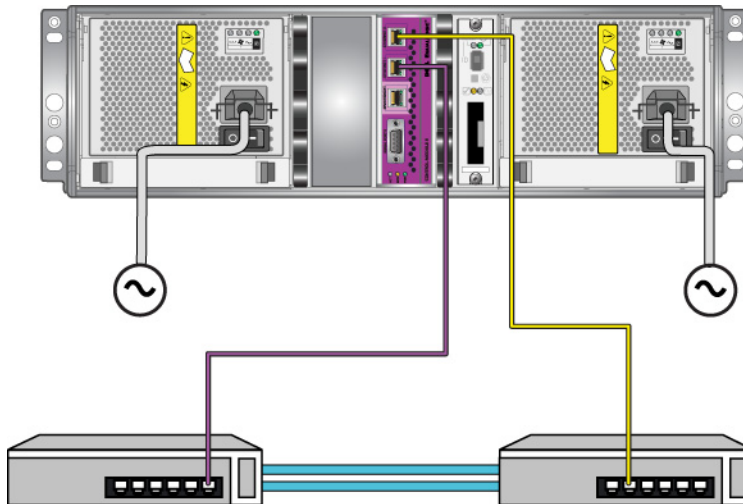

For a dual control module array, the minimum network configuration is a network connection to Ethernet 0 on both control modules. Although this configuration protects against control module failover, it is still a potential point of failure (for

example, if the network cable connected to the active control module is disconnected).

Figure 3-4 shows the minimum network configuration for a dual control module array. Cables are connected to Ethernet 0 on both control modules.

Figure 3-4: Minimum Network Configuration

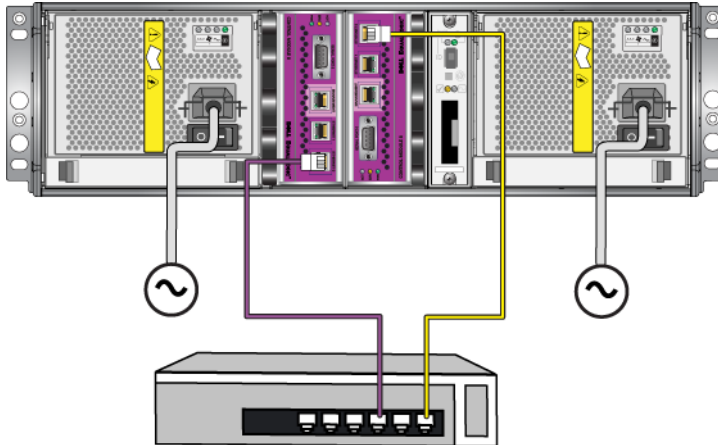
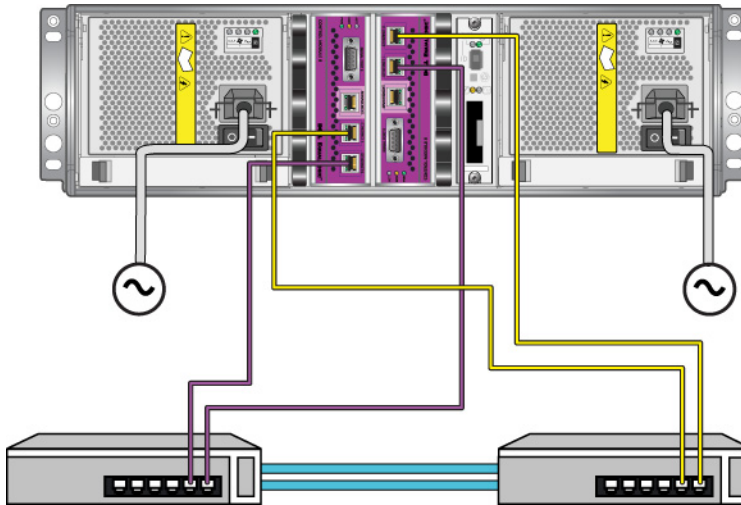

Figure 3-5 shows the recommended network configuration for a dual control module array, which is to connect Ethernet 0 and Ethernet 1 to different switches, connected with interswitch links. This configuration provides the highest network availability and the maximum network bandwidth.

Figure 3-5: Recommended Network Configuration

Control Module Handling Requirements

Follow these control module handling requirements:

- **Protect control modules from electrostatic discharge.** Always wear an electrostatic wrist strap when handling a control module, as described in *Using an Electrostatic Wrist Strap* on page 1-5. When not installed, store a control module in an antistatic bag or place it on a surface protected from electrostatic discharge.
- **Do not remove a control module from an array while the control modules are synchronizing.** When synchronization completes, a console message will appear. Also, the ACT LED on the secondary control module will be orange.
- **Do not leave a control module slot empty.** In an array with one control module, always attach a blank face plate to the empty control module slot.
- **Store control modules properly.** Store a control module in its original packaging or in an antistatic bag or place the control module on a surface protected from electrostatic discharge.

Removing a Control Module

If a control module fails, remove it and replace it with a functioning control module. Do not remove a failed control module until you are ready to replace it.

You may need to temporarily remove a control module to replace its compact flash or micro SD card.

Notes: For proper cooling, do not leave a control module slot empty. If an array will operate for a long time with only one control module, you must install a blank control module in the empty slot. You can order a blank control module from your PS Series array service provider.

If you remove the active control module, there will be a short interruption as failover to the secondary control module occurs.

You can partially or completely remove a control module without shutting down the array if the remaining control module has at least one connected and functioning network interface. If you remove the active control module (the LED labeled ACT will be green), there will be a short interruption as failover to the secondary control module occurs.

Otherwise, if possible, cleanly shut down the array before removing the module, as described in *Shutting Down and Restarting an Array* on page 1-5.

Caution: Do not remove a control module from an array while the control modules are still synchronizing. A message will appear on the console when synchronization completes. The ACT LED on the secondary control module will be orange when synchronization completes.

Before removing a control module:

- Attach an electrostatic wrist strap, as described in *Using an Electrostatic Wrist Strap* on page 1-5.
- Disconnect any serial or network cables attached to the control module. Optionally, re-attach the network cables to the functioning control module to provide uninterrupted data access.

To remove a control module:

1. Open the control module latches by squeezing together the release mechanism for each latch and then rotating each latch outwards. This will disengage the control module from the array. See Figure 3-6.

Figure 3-6: Opening a Control Module Latch

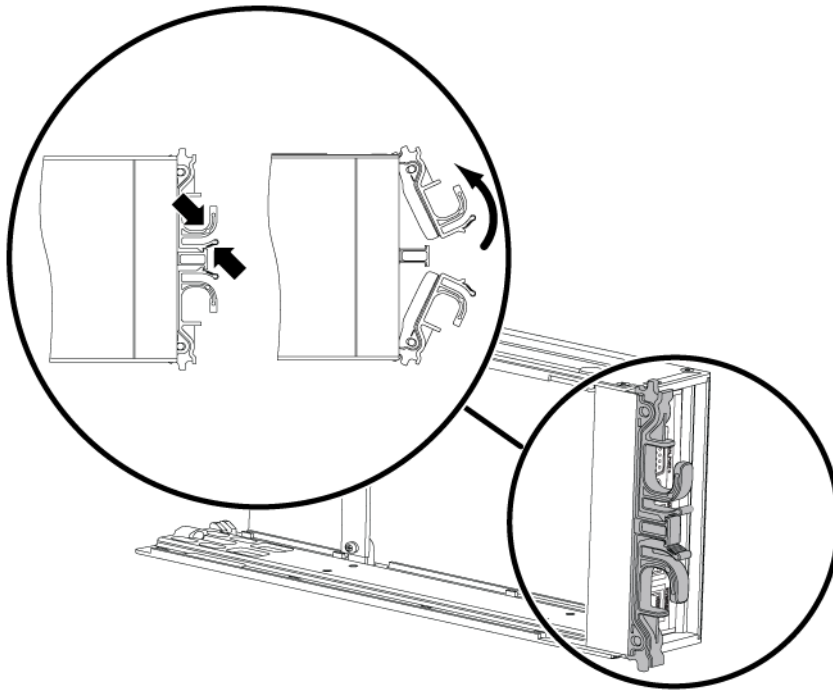

2. Hold the latches and carefully slide the control module from the slot. See Figure 3-7.

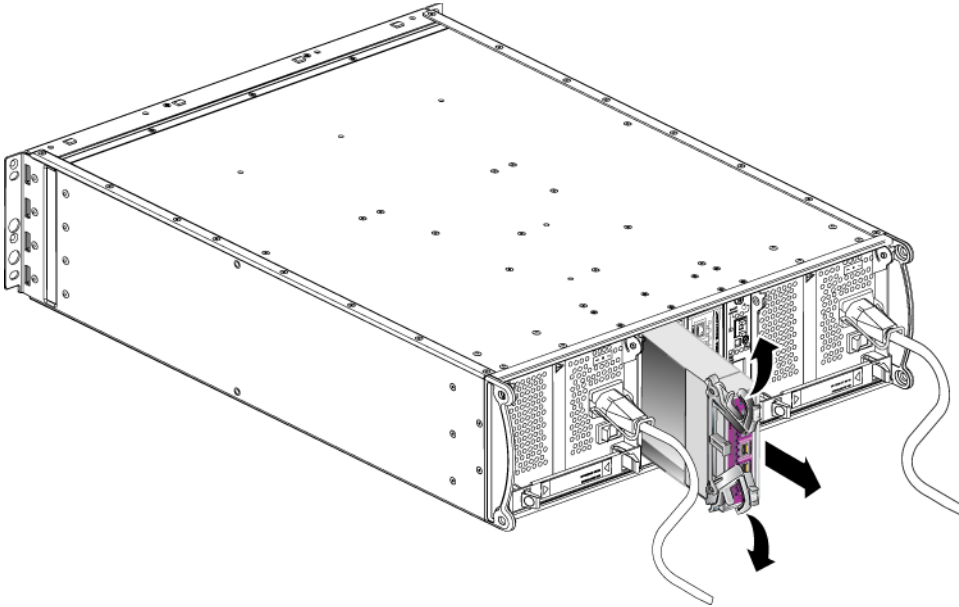
Figure 3-7: Removing a Control Module

3. Place the control module on a flat surface where it will be protected from electrostatic charge.

Caution: To avoid damage, do not place anything on top of the control module.

4. If you are replacing a failed control module, remove the compact flash or micro SD card from the failed control module and install it in the replacement control module. This will make sure that the new control module is running the correct firmware.
 - For a Type 8 control module, see *Replacing a Compact Flash Card* on page 3-16.
 - For a Type 9 control module, see *Replacing a Micro SD Card* on page 3-18.

To install a replacement control module, or to reinstall a control module after you have replaced the firmware card, see *Installing a Control Module* on page 3-13. Do not operate an array with an empty control module slot.

Return the failed control module in the packaging in which the replacement module was shipped. Contact your PS Series support provider for information about returning hardware.

Installing a Control Module

You can install a control module without shutting down the array.

Caution: Do not mix control module types in an array.

Before installing a control module, make sure the firmware on the control module matches the firmware running on the functioning control module. See *Maintaining Control Module Firmware* on page 3-4.

Control modules are installed vertically in the array, with the latch mechanism facing the adjacent power supply and cooling module. See Figure 3-8.

Figure 3-8: Correct Control Module Orientation

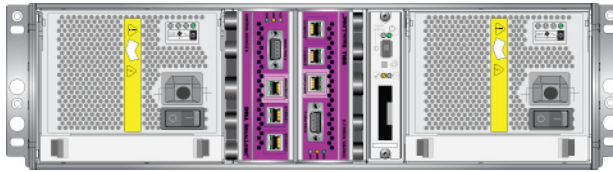

Caution: Wear electrostatic protection when handling a control module. See *Using an Electrostatic Wrist Strap* on page 1-5.

To install a control module:

1. Open the control module latches by squeezing together the release mechanism for each latch and then rotating each latch outwards. See Figure 3-6.
2. Correctly orient the control module with the latch mechanism facing the adjacent power supply and cooling module.
3. Hold the latches and slide the control module into the slot until you feel resistance.
4. Rotate each latch inward, while pushing the control module completely into the slot. The latches will snap into place (Figure 3-9).

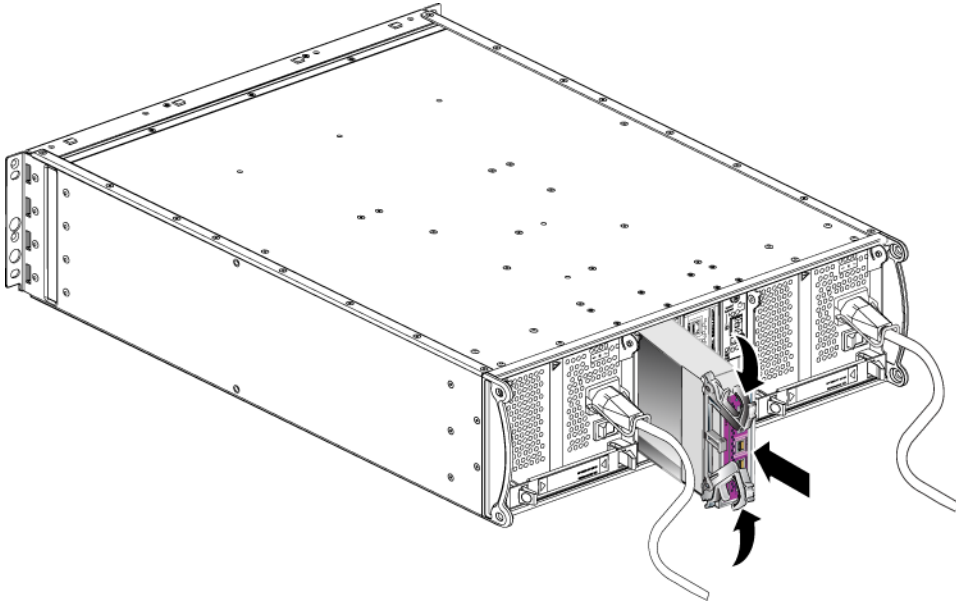
Figure 3-9: Installing a Control Module

5. Connect the network cables as described in *Connecting Network Cables* on page 3-6.
6. If the array was shut down, turn on power to the array.
7. Examine the LEDs, as described in *Interpreting Control Module LEDs* on page 3-2. Also, check the GUI Member Controllers window or run the CLI `member select show controllers` command. The control module status will be either *active* (if there is only one control module) or *secondary*.

If two control modules are installed but only one appears in the GUI or CLI, the control module may not be properly installed. Re-install the control module. If both control modules still do not appear in the GUI or CLI, they may not be running the same firmware. Contact your array support provider.

Notes: When connected, a control module cache battery may begin to charge. If the low-battery-safe cache policy is enabled (the default), the array will operate in write-through mode until the cache battery is fully charged.

However, if you need optimal performance before the battery is fully

charged, as soon as the battery status is good/charging, you can *temporarily* disable the low-battery-safe policy and force the array to operate in write-back mode. Make sure to re-enable the low-battery-safe policy when the battery is fully charged. See the PS Series *Group Administration* manual for information about cache policies.

Replacing the Firmware Card

The control modules in a PS Series array contain a firmware card that runs the PS Series firmware. The physical characteristics of the firmware card depend on the control module type:

- A Type 8 control module includes a compact flash card
- A Type 9 control module includes a micro SD card

If a control module fails, remove the compact flash or micro SD card from the failed control module and install the card in the replacement control module. This will make sure that the new control module is running the correct firmware. See *Replacing a Compact Flash Card* on page 3-16 or *Replacing a Micro SD Card* on page 3-18 for more information.

You can access the firmware card by sliding the control module *partially* from the slot. If you completely remove the control module, place it on a surface that is protected from electrostatic discharge.

You can partially or completely remove a control module without shutting down the array if the remaining control module has at least one connected and functioning network interface,. If you remove the active control module (the LED labeled ACT will be green), there will be a short interruption as failover to the secondary control module occurs.

Before replacing a firmware card:

- Attach an electrostatic wrist strap, as described in *Using an Electrostatic Wrist Strap* on page 1-5.
- See *Removing a Control Module* on page 3-9 for instructions on removing a control module.

Caution: Be careful not to damage the circuit board. Do not use sharp instruments to remove the card.

Replacing a Compact Flash Card

1. Firmly grasp the sides of the card and slide it from the connector. Make sure not to damage the card or the control module circuit board. See Figure 3-10.

Figure 3-10: Removing a Compact Flash Card

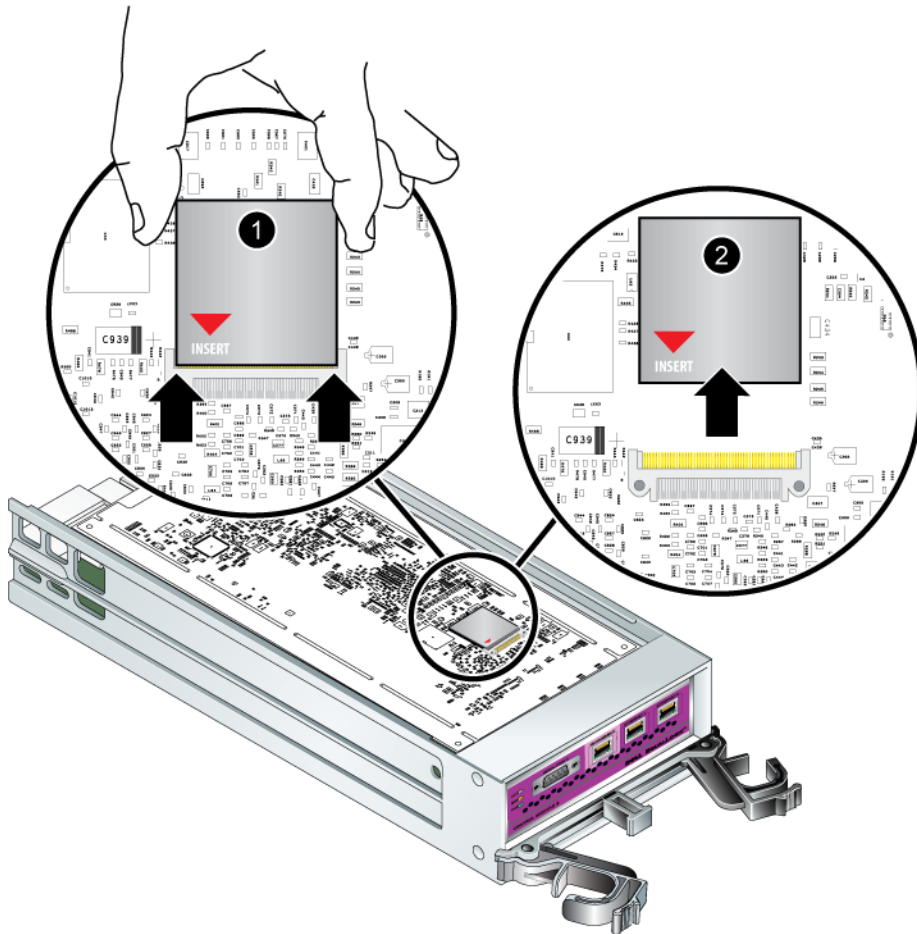

2. To insert the compact flash card in the replacement control module, align the grooves on the sides of the card with the connector, making sure the red arrow on the card is pointing towards the connector. See Figure 3-11.

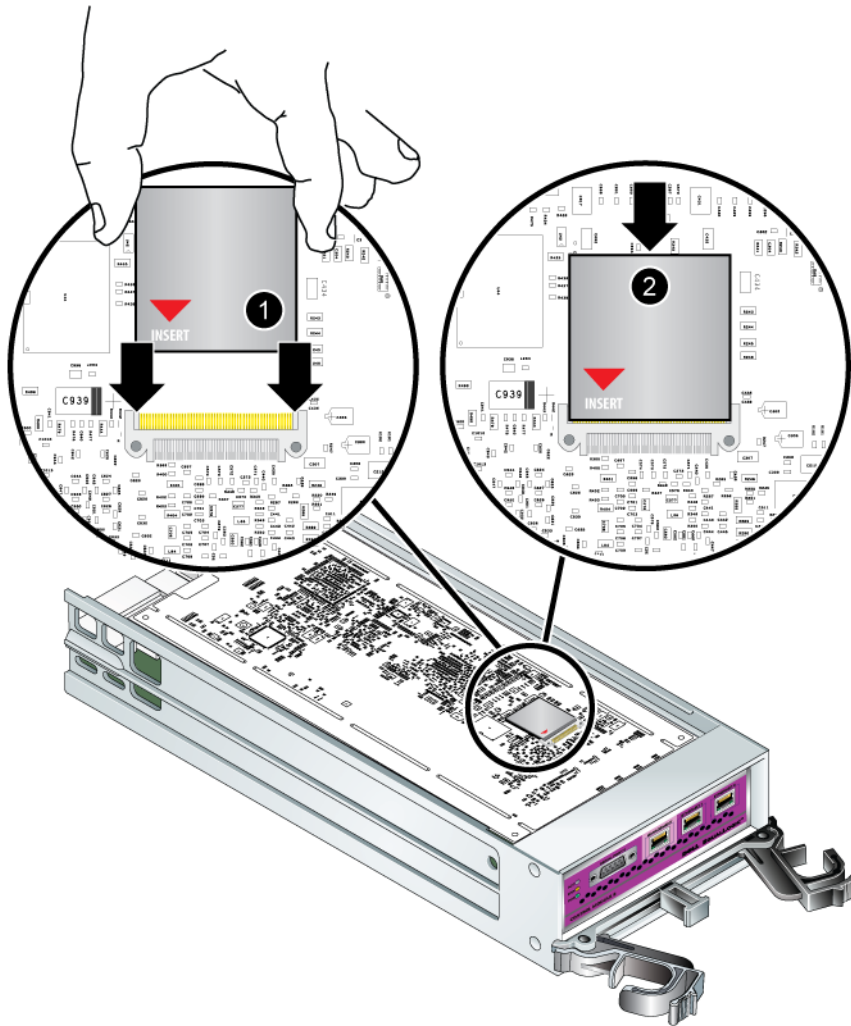
Figure 3-11: Inserting a Compact Flash Card

3. Firmly press the compact flash card into place.
4. Install the control module. See *Installing a Control Module* on page 3-13.

Replacing a Micro SD Card

1. Firmly push the card into its housing to release the spring mechanism (Figure 3-12). The micro SD card will be partially ejected from the housing.

Figure 3-12: Ejecting the Micro SD Card

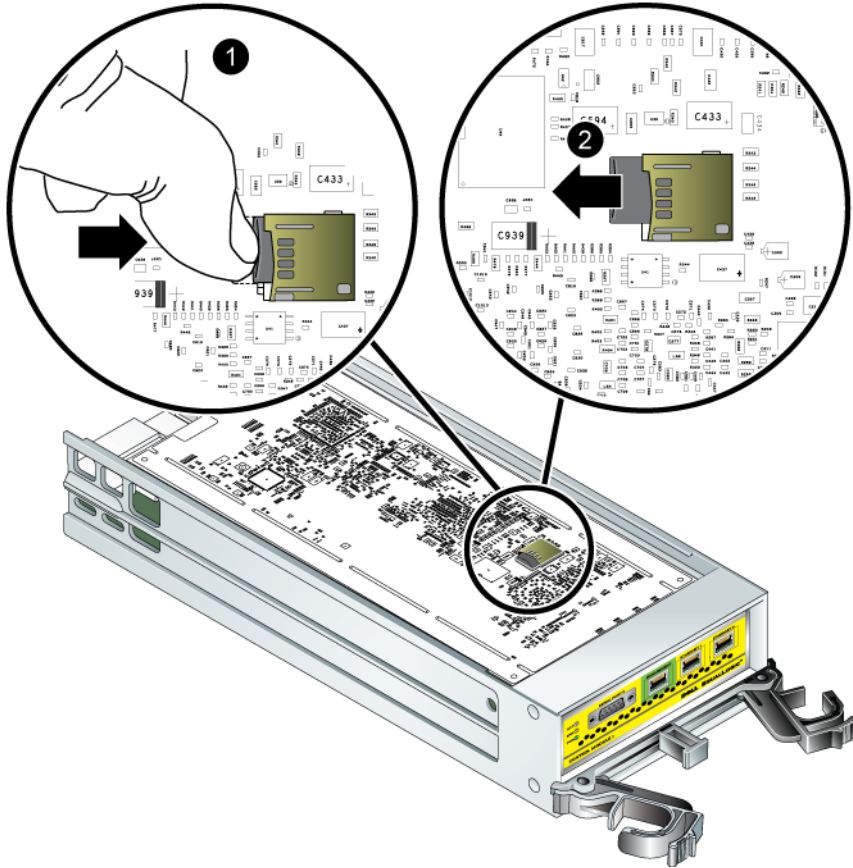

2. Gently pull the card straight out of the housing.
3. Place the micro SD card on a flat surface where it will be protected from electrostatic charge.
4. To insert the micro SD card in the replacement control module, align the micro SD card so the arrow on the card points towards the housing. See Figure 3-13.

5. Firmly press the card into the housing until it clicks into place. Make sure you cannot pull it out.

Figure 3-13: Inserting the Micro SD Card

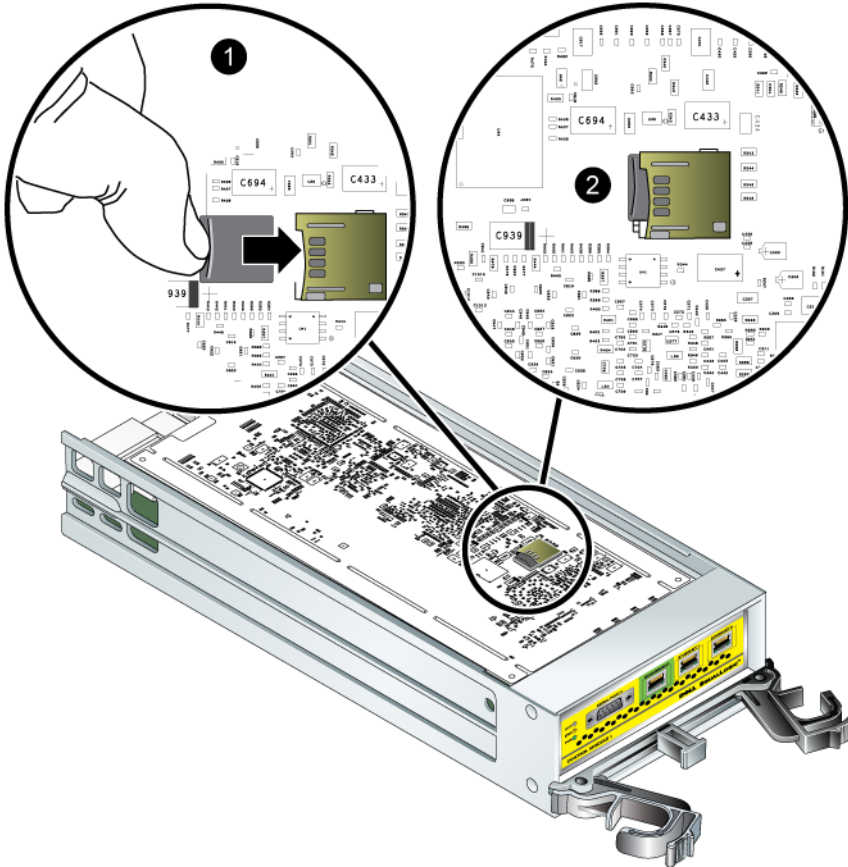

6. Install the control module. See *Installing a Control Module* on page 3-13.

After you replace the micro SD card, make sure the control module is operational. See *Interpreting Control Module LEDs* on page 3-2.

4 Maintaining Power Supply Modules

The array includes two hot-swappable, combination power supply and cooling modules.

Interpreting the LEDs

Use the power supply and cooling module LEDs, shown in Figure 4-1 and described in Table 4-1, to determine the module status and identify problems. The power supply and cooling module LEDs show the power, fan, and array status.

Figure 4-1: Power Supply and Cooling Module LEDs

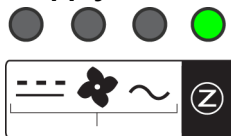



Table 4-1: Power Supply and Cooling Module LEDs

LED	Color	Description
---	Off	Normal operation.
	Orange	DC power failure.
	Off	Normal operation.
	Orange	Fan failure.
~	Off	Normal operation.
	Orange	AC power failure.
	Off	No power.
	Green	Normal operation.

Identifying Failures

You can identify a power supply and cooling module failure by any or all of the following:

- **LEDs.** See *Interpreting the LEDs* on page 4-1.
- **Messages.** A message on the console, in the event log, or in the Group Manager GUI Alarms panel describes a power supply and cooling module failure.

- **Group Manager GUI and CLI output.** The GUI Member Enclosure window or the CLI `member select show enclosure` command shows a power supply and cooling module failure.

Note: When viewing the rear of the array, power supply 0 is on the right, and power supply 1 is on the left. See Figure 1-3 on page 1-2 for details.

Removing a Power Supply and Cooling Module

If a power supply and cooling module fails, you must replace the module as soon as possible, although an array can operate with only one working module. For proper array cooling, do not remove a failed module until you are ready to replace it.

You can remove a power supply and cooling module from an array without affecting array operation if the second module is installed and functioning. Otherwise, if possible, cleanly shut down the array before removing the module, as described in *Shutting Down and Restarting an Array* on page 1-5.



Caution: Wear electrostatic protection when handling a power supply and cooling module. See *Using an Electrostatic Wrist Strap* on page 1-5.

To remove a power supply and cooling module:

1. Turn off power to the module.
2. Disengage the power cable strain relief and disconnect the power cable.
3. See Figure 4-2. Squeeze the latches inward (callout 1) to release the handle and then rotate the handle upward (callout 2).

Figure 4-2: Releasing the Handle

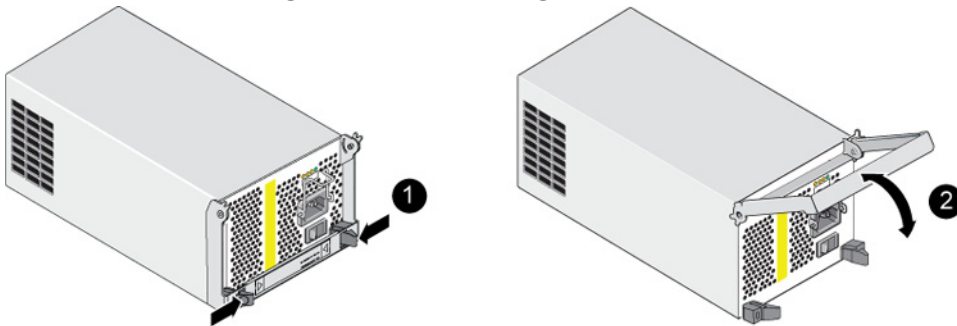

4. Hold the handle and pull the module from the slot. See Figure 4-3.

Caution: The module is heavy; support it with two hands.

Figure 4-3: Removing a Power Supply and Cooling Module

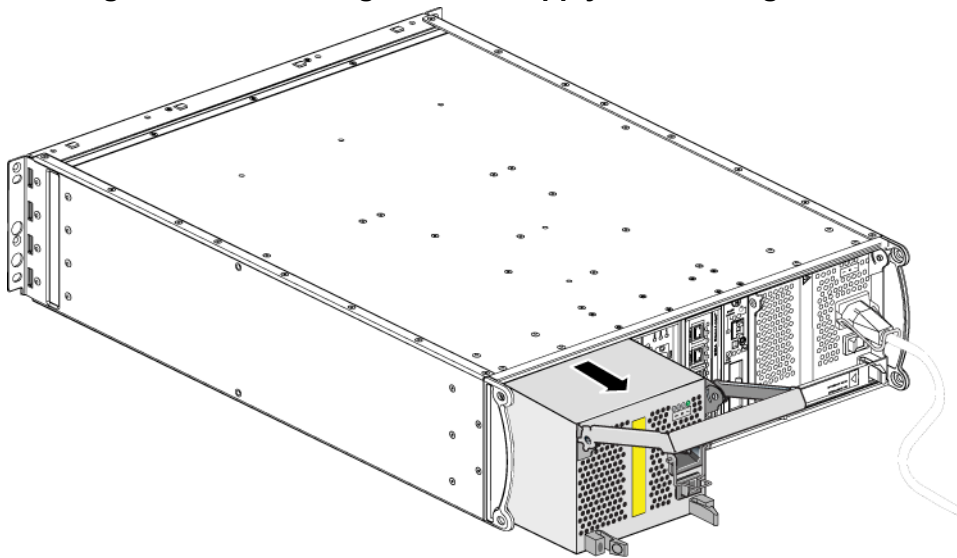

Installing a Power Supply and Cooling Module

Caution: The module is heavy; support it with two hands.

To install a power supply and cooling module in an array:

1. Attach an electrostatic wrist strap, as described in *Using an Electrostatic Wrist Strap* on page 1-5.
2. Refer back to Figure 4-2. Squeeze the latches inward (callout 1) to release the handle and then rotate the handle upward (callout 2).
3. Hold the handle and slide the module into the slot, until you feel resistance. See Figure 4-4.

Figure 4-4: Installing a Power Supply and Cooling Module

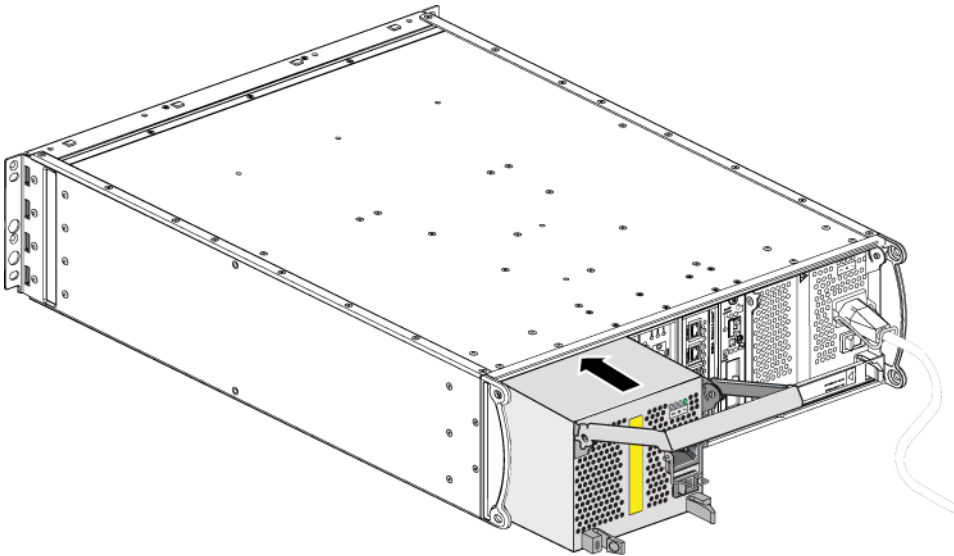

4. Rotate the handle downward until it engages with the latches and the module is completely inserted. Refer back to Figure 4-2.
5. Attach the power cable to the module. If your PS Series array was shipped with a power cable, use this cable to meet safety requirements.

6. Use the cable strain relief to secure the power cable to the array, as shown in Figure 4-5.

Note: If you need to reverse the cable strain relief wire for your power cable configuration, press the wire ends together as shown in Figure 4-5 to disengage the wire from the power plug socket. Reverse the wire and re-attach it to the socket.

Figure 4-5: Using the Cable Strain Relief

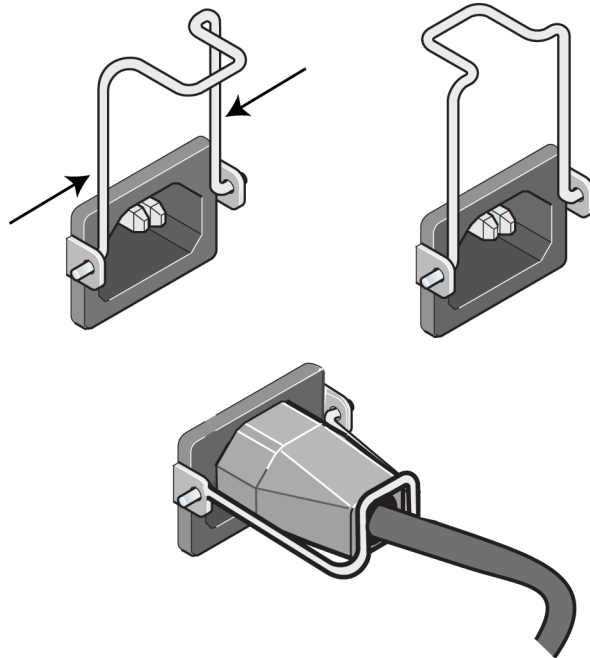

7. Turn on power to the power supply and cooling module. Initialization generally takes from one to ten seconds. When initialization completes, the power LED is green and an event message states that fans have returned to their normal speed.
8. To make sure the new module is working, make sure there are no red LEDs. Also, examine the GUI Member Enclosure window or run the CLI `member select show enclosure` command. Make sure the status is `on`.

Caution: After installing a power supply and cooling module, wait until the new module initializes before removing the other module. New

module initialization can take from one to ten seconds. When complete, the power LED is green and an event message states that fans have returned to their normal speed.

A Environmental, Power, and Other Specifications

Table A-2 describes the environmental, power, and physical specifications for a PS4000 array.

Table A-2: PS4000 Array Specifications

Component	Requirement
Weight of fully-loaded array	35 kg (77.6 lb)
Operating temperature	5 to 35 °C (41 to 95 °F)
Storage temperature	-30 to 60 °C (-22 to 140 °F)
Maximum operating altitude	3048 meters (10,000 feet)
Operational relative humidity	20% to 80% noncondensing
Storage relative humidity	5% to 80% noncondensing
Thermal output (fully-loaded array)	1700 BTU/hour (SAS disks) 1550 BTU/hour (SATA disks)
Operational shock	5g peak 1/2 sin, for 10ms
Operational vibration	.21 G _{rms} 5 to 500 Hz Random
Input voltage	100 to 240 VAC (auto-sensing)
Input frequency	48 - 62 Hz
System input power	530 VA (maximum)
Each power supply	450 watts DC output Maximum input power: 0.7 KVA Input current: 7 – 3.5A
Chassis dimensions	13 cm by 48.26 cm by 55.1 cm (5.12 in. by 19 in. by 21.7 in.)

Index

A

array

- back panel 1-2
- batteries 3-1
- control module restriction 3-13
- control modules 3-1
- cooling 4-1
- disk types 2-3
- environmental requirements A-1
- failure indications 1-2
- fans 4-1
- firmware 3-4
- front panel 1-1
- LEDs 1-2, 2-3, 3-2, 4-1
- minimum network configuration 3-6
- network connection guidelines 3-5
- power supplies 4-1
- protecting from discharge 1-5
- serial number 1-2, 1-5
- shutdown procedure 1-5
- specifications A-1

B

batteries

- charging 3-14
- servicing 3-1

C

- cable strain relief, using 4-5
- cables (network), connecting 3-6
- cables (power), connecting 4-4
- control modules
 - batteries 3-1
 - charging cache battery 3-14
 - checking proper installation 3-14
 - disk support 3-1
 - failover behavior 3-3

- failure indications 3-3
- firmware identification 3-4
- firmware requirements 3-4, 3-13, 3-15
- handling requirements 3-9
- installing in array 3-13
- LEDs 3-2
- locating 3-3
- micro SD card, replacing 3-4, 3-15
- removing from array 3-9
- restriction on mixing 3-1, 3-13
- supported disk type 3-13
- synchronizing 3-9, 3-10
- types 3-1, 3-13
- verifying operational status 3-14

cooling

- indications of failure 4-1
- initialization 4-5
- installing module in array 4-4
- LEDs 4-1
- locating modules 4-2
- removing module from array 4-2
- verifying operational status 4-5

D

disks

- control module support 2-1
- failure behavior 2-5
- failure indications 2-4
- handling requirements 2-4
- identifying type 2-3
- installing in array 2-7
- LEDs 2-3
- locating 2-4
- protecting 2-4
- removing from array 2-5
- SAS 2-1
- SATA 2-1
- types 2-1

- verifying operational status 2-8
- E**
- electrostatic protection, using 1-5
- environmental requirements A-1
- F**
- failover
 - control module 3-3, 3-4
 - network connection 3-4
- failure indications
 - array 1-2
 - control modules 3-3
 - cooling 4-1
 - disks 2-4
 - power 4-1
- fans
 - failure indications 4-1
 - initialization 4-5
 - installing module in array 4-4
 - LEDs 4-1
 - locating modules 4-2
 - maintaining 4-1
 - removing module from array 4-2
 - verifying operational status 4-5
- firmware
 - identifying 3-4
 - requirements 3-4, 3-15
- Flow Control recommendation 3-6
- G**
- Gigabit Ethernet recommendation 3-5
- H**
- hosts
 - Flow Control recommendation 3-6
 - Jumbo Frames recommendation 3-6
- J**
- Jumbo Frames recommendation 3-6

- L**
- LEDs
 - control module 3-2
 - cooling modules 4-1
 - disks 2-3
 - network interfaces 3-2
 - operations panel 1-2
 - power supplies 4-1
- M**
- member
 - increasing bandwidth 3-5
 - multipath I/O recommendation 3-5
 - network connection guidelines 3-5
 - subnet access recommendation 3-5
- micro SD card
 - firmware requirements 3-4
 - identifying firmware 3-4
 - replacing 3-4, 3-15
- N**
- network
 - cable connections 3-7
 - connection guidelines 3-5
 - failure protection 3-4
 - improving performance 3-5
 - increasing availability 3-7
 - increasing performance 3-7
 - minimum configuration 3-6
 - recommendations 3-5
- network interfaces
 - configuring 3-5
 - connecting 3-6
 - LEDs 3-2
- O**
- operations panel
 - LEDs 1-2
 - servicing 1-2
- P**
- physical requirements A-1

- power cables
 - restriction 4-4
- power supplies
 - cable strain relief 4-5
 - indications of failure 4-1
 - initialization 4-5
 - installing module in array 4-4
 - LEDs 4-1
 - locating modules 4-2
 - maintaining 4-1
 - removing module from array 4-2
 - verifying operational status 4-5

R

- requirements
 - array handling 1-5
 - control modules 3-9
 - cooling 4-2
 - disks 2-4
 - environmental A-1
 - firmware 3-4
 - network 3-6
 - physical A-1
 - power 4-2
 - power cables 4-4

S

- SAS disks
 - identifying 2-3

- supported control module 3-1
- SATA disks
 - identifying 2-3
 - supported control module 3-1
- serial number label 1-2, 1-5
- shutting down an array 1-5
- Spanning-Tree recommendation 3-6
- specifications, array A-1
- status
 - control modules 3-3
- switches, recommendations
 - Flow Control 3-6
 - Jumbo Frames 3-6
 - Spanning-Tree 3-6
 - unicast storm control 3-6
 - VLAN 3-6

T

- tag, serial number 1-2

U

- unicast storm control recommendation
 - 3-6

V

- VLAN recommendation 3-6

