



Dell EqualLogic FS7610 Series Appliances

Hardware Owner's Manual

© Copyright 2011–2013 Dell Inc. All rights reserved.

Dell™ and EqualLogic® are trademarks of Dell Inc.

All trademarks and registered trademarks mentioned herein are the property of their respective owners.

Information in this document is subject to change without notice.

Reproduction in any manner whatsoever without the written permission of Dell is strictly forbidden.

Published: October 2013

Part Number: 110-6179-EN-R1

Table of Contents

Preface	v
1 Basic Appliance Information	1
Appliance Components	1
Connecting an Appliance to Power	4
Turning Power On and Off	5
Required Tools	6
Technical Specifications	6
2 Replacing Components	9
Safety Recommendations	9
Required Tools	9
Using an Electrostatic Wrist Strap	9
Replacing a Controller	10
Installing a Controller	11
Replacing SFP+ Transceivers	12
Replacing a Power Supply	13
Replacing a Cooling Fan	16
Replacing the Appliance	18
Returning Failed Hardware	18
3 What to Do Next	19
Appendix A: NOM Information (Mexico Only)	21
Glossary	23

Preface

Dell™ EqualLogic® FS Series appliances, coupled with PS Series arrays, offer a high-performance, high-availability, scalable NAS solution. This manual describes how to maintain and troubleshoot the customer-replaceable components of the EqualLogic FS7610 appliance.

Audience

The information in this guide is intended for hardware administrators responsible for maintaining EqualLogic FS7610 hardware.

Related Documentation

For detailed information about FS Series appliances, PS Series arrays, groups, volumes, array software, and host software, log in to the [Documentation page](#) at the customer support site.

Dell Online Services

You can learn about Dell products and services with this procedure:

1. Visit [dell.com](#) or the URL specified in any Dell product information.
2. Use the locale menu or click on the link that specifies your country or region.

Dell EqualLogic Storage Solutions

To learn more about Dell EqualLogic products and new releases, visit the Dell EqualLogic Tech Center site: [delltechcenter.com/page/EqualLogic](#). Here you can also see articles, demos, online discussions, and more details about the benefits of our product family.

Technical Support and Customer Service

Dell support service is available to answer your questions about PS Series SAN arrays and FS Series appliances.

Contacting Dell

If you are a customer in the United States or Canada in need of technical support, call 1-800-945-3355. If you are outside of the United States or Canada, visit [support.dell.com/support/topics/global.aspx](#).

If you have an Express Service Code, have it ready. The code helps the Dell automated support telephone system direct your call more efficiently.

Warranty Information

The FS7610 appliance warranty is included in the shipping box. For information about registering a warranty, visit [eqsupport.dell.com/utility/form.aspx?source=warranty](#).

Note, Caution, and Warning Symbols



A NOTE symbol indicates important information that helps you make better use of your hardware or software.



A CAUTION symbol indicates potential damage to hardware or loss of data if instructions are not followed.



A WARNING symbol indicates a potential for property damage, personal injury, or death.

1 Basic Appliance Information

This chapter contains information about the location and basic operation of the components in a Dell™ EqualLogic® FS7610 NAS appliance. The chapter also includes general operating procedures such as power ON and power OFF operations, and how to return failed components.

Appliance Components

The only customer-replaceable components in the appliance are the bezel and the fans, on the front of the appliance, and the controllers and power supplies, on the back of the appliance.

Appliance Front-Panel Features

Figure 1 and Figure 2 show the front panel of the FS7610 NAS appliance. Table 1 lists the front-panel LED descriptions.

Figure 1: FS7610 Front Panel (Bezel Off, Cover Closed)

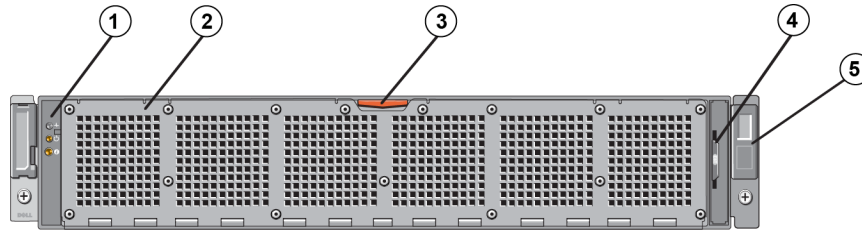



Table 1: FS7610 Front-Panel Components

Number	Component
1	System health indicator, power, and system identification LEDs (see Table 2 for details)
2	Cooling fan access door Encloses and protects the six hot-swappable cooling fans.
3	Cooling fan access door release latch Press the access door release latch to expose the hot-swappable cooling fans.
4	Information tag A slide-out label panel listing the system NIC and BMC MAC addresses for both controllers
5	Service tag Displays the appliance service tag information (identical to the service tag information on the back panel). You might be asked for this information when you call technical support.

Table 2: Front-Panel LED Descriptions

LED Indicator	Icon	State and Description
System Health Indicator		The system status LED lights only when the system power is on: Solid blue—Normal operation. Blinking amber—One of the controllers is reporting hardware errors, battery errors, or a controller is missing.



LED Indicator	Icon	State and Description
Power-On Indicator		The power LED lights green when at least one power supply is connected to a power source and is supplying power to the system.
System Identification Button		Identification buttons on the front and back panels locate a particular system within a rack. Press the front identification button and the system status indicator on the back flashes until either button is pressed again. Blinking blue—Identification on. Solid blue—Identification off.

Figure 2: FS7610 Front Panel (Cover Open)



The fans are numbered 1 through 6, from left to right.

Appliance Back-Panel Features

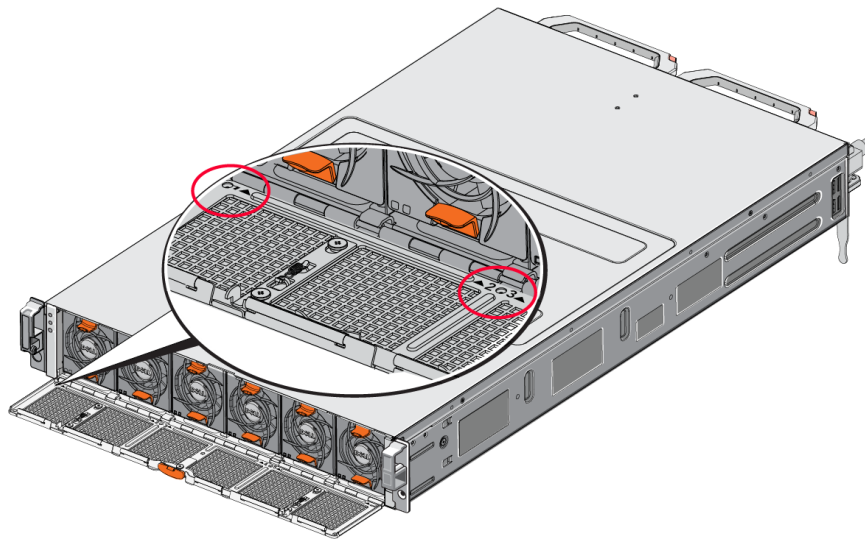
Figure 3 and Table 3 describe the back panel of the FS7610 NAS appliance. Table 4 describes the LEDs for each controller.

Figure 3: FS7610 Back Panel

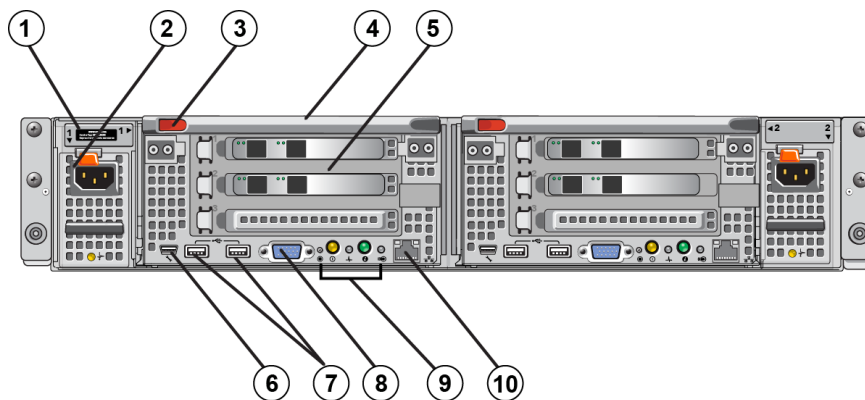







Table 3: FS7610 Back-Panel Components

Number	Component
1	Service tag Displays the appliance service tag information (identical to the service tag information on the front panel).
2	Power supply (one of two) Left: PSU1 Right: PSU2
3	Controller release latch
4	Controller handle
5	Controller (one of two); redundant NAS processing unit, each containing a backup power supply (BPS) Left: Controller 1 Right: Controller 2
6	Serial COM port (mini USB connector). Allows you to connect a serial device to the system. This connector is for service only. Use this connector only if asked to do so by Dell support.
7	USB port
8	Video port
9	From left to right: Service Action Button, Power-On Indicator/Power Button, Controller Health Indicator, System Identification Button, and Cache Active/Off-Load LED (see Table 4).
10	Remote KVM

Table 4: Controller LED States and Descriptions

LED Indicator/ Button	Icon	State and Description
Service Action Button		Used for troubleshooting certain errors; press using the end of a paper clip. Press and hold the button for 10 seconds to generate an SCI (System Control Interrupt).  Use this button only if directed by qualified support personnel or after consulting the operating system's documentation.
Controller State Indicator/Power-On Button		Controls the power supply to the appliance and indicates its state: <ul style="list-style-type: none"> When the controller is ON, press and release to shut down. When the controller is OFF, press and release to power the controller on. Solid amber—The controller is ON and about to enter system power-on self-test (POST). If the controller is ON but is not responding, the controller might have a hardware failure that is not allowing it to start the BIOS POST. Slowly blinking (flashes once every two seconds) amber—The controller is currently in BIOS POST or option ROM load stage. If the controller is not responding, it might indicate that a failure has occurred in either POST or option ROM load phase. Slowly blinking green (flashes once every two seconds)—The controller is attempting to start the operating system. If the controller is not responding, slow blinking green might indicate that the operating system did not load correctly. Fast blinking green (flashes five times per second)—The controller is in standby state waiting to be clustered.

LED Indicator/ Button	Icon	State and Description
		<p>Solid green—The controller is clustered and fully functional.</p> <p>Alternating blinking amber/green—The expected hardware configuration does not match the actual hardware.</p> <p>Unlit—Controller is in power OFF mode.</p>
Controller Health Indicator		<p>Indicates health of the controller.</p> <p>Solid blue—Normal operation.</p> <p>Blinking amber—One of the controllers is reporting hardware errors, battery errors, or one controller is missing.</p>
System Identification Button		<p>Identification buttons on the front and back panels locate a particular system within a rack. Press the front identification button and the system status indicator on the back flashes until either button is pressed again.</p> <p>Blinking blue—Identification on.</p> <p>Solid blue—Identification off.</p>
Cache Active/Off-Load LED		<p>Indicates when the storage controller contains cached write data and is transferring the cache from memory to the hard drive.</p> <p>Solid green—One controller can be removed without losing cached data. Do not remove both controllers.</p> <p>Blinking amber—Cached data is being transferred from the memory to the hard drive (moving from mirroring mode to journaling mode).</p> <p>Off—Indicates that no write data is in the cache; it is safe to remove the controller.</p>

Connecting an Appliance to Power

1. Remove the power cables from the shipping box.
2. Plug the power cables into the appliance power supplies. Wrap the hook-and-loop strain relief around the power cable, as shown in [Figure 4](#).
3. Connect the appliance to a power source.

Figure 4: Secure the Power Cable with the Strain Relief

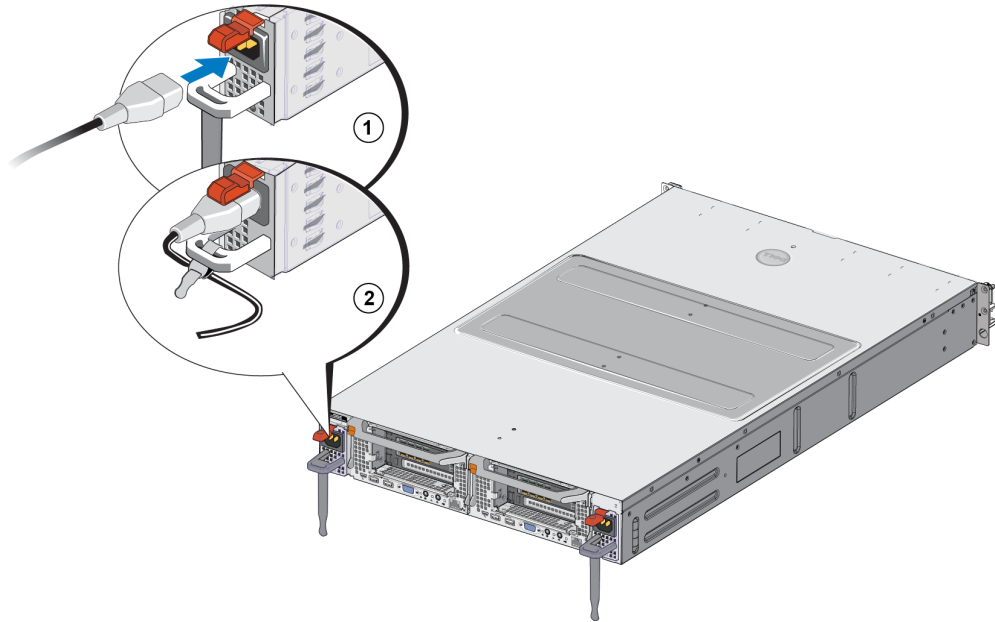

The appliance turns on as soon as the power supplies are connected to a live power source.

 Each controller contains a backup power supply (BPS). The BPS batteries begin to charge when the appliance is connected to power. A full charge takes up to eight hours to complete; the NAS appliance is not fully redundant until the battery is fully charged. The BPS provides the clustered solution enough time to write all cached data to disk if the controller experiences a loss of power.

4. Check the LED on the front panel to make sure the appliance is operational (see [Figure 2](#)).

Turning Power On and Off

Normally, the appliance turns on when the power cables are connected to a source of live power. An LED indicator on the front of the appliance indicates if power is supplied to the appliance and if the appliance is operational. However, each controller has a power button on its back (the power LED) that enables you to turn off power to an individual controller for service purposes.

In addition, the power supplies have an LED that shows if power is present or if a power fault has occurred, as described in [Table 5](#).

Table 5: Troubleshooting – Power Supply LED

LED Color and Patterns	Description
OFF	Power is not connected
Green	Indicates that a valid power source is connected to the power supply and that the power supply is operational
Amber	Indicates a problem with the power supply

Turning Controller Power Off

If you need to replace a controller, turn off the power to start a shutdown. Use a small, thin tool such as a #1 Phillips screwdriver to press and release the power LED button on the back of the controller you plan to remove. See [Figure 5](#).

Figure 5: Turning the Controller Power On or Off

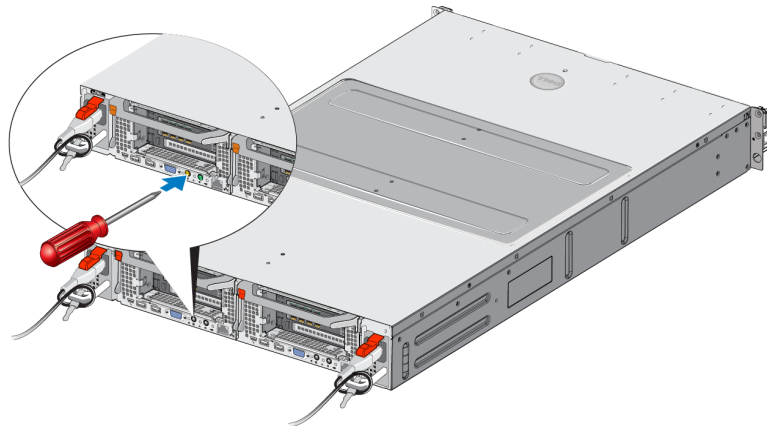

Turning Controller Power On

If you shut down power to a controller, or replace a failed controller, you might need to turn it back on manually. Use a small, thin tool such as a #1 Phillips screwdriver to press and release the power LED button on the controller.

The power LED first appears solid amber, then slowly blinks to indicate that the controller is powering up. The LED blinks green when the controller loads the operating system, and changes to solid green when the controller is clustered and fully functional. See [Table 5](#) for a description of all the power supply LED states.

Required Tools

If you are installing the appliance in a rack, you will need a #2 Phillips screwdriver (not supplied).

Technical Specifications

[Table 6](#) lists the technical specifications for the NAS appliance.

Table 6: FS7610 NAS Appliance Technical Specifications

Category	Rating
AC Power Supply (per power supply)	
Wattage	Output 717 W
Heat dissipation	2446 BTU/hr
	 The heat dissipation is calculated using the power supply wattage rating. The heat dissipation values are for the entire system, which includes the chassis and two controllers.

Voltage	90 VAC to 264 VAC, autoranging, 47 Hz/63 Hz  This system is also designed to be connected to IT power systems with a phase to phase voltage not exceeding 230 V.
Battery Power Supply	
Battery	12.8 V to 13.2 V, 4.8 Ah to 6 Ah, 63 Wh to 77 Wh
Physical	
Height	86.4 mm (3.4 in.)
Width	481.5 mm (18.96 in.)—with rack flange 446.3 mm (17.6 in.)—without rack flange
Depth	813.0 mm (32.0 in.)—with bezel and handle 741.0 mm (29.2 in.)—without bezel and handle
Weight (maximum configuration)	30.5 kg (67 lb.)
Weight (empty)	12.86 kg (28.36 lb.)
Environmental	
Operating temperature	Continuous operation: 5°C to 40°C (41°F to 104°F) with a maximum temperature gradation of 20°C (68°F) per hour
Storage temperature	–40°C to 60°C (–40°F to 140°F) with a maximum temperature gradation of 20°C per hour
Operational relative humidity	20% to 80% (non-condensing) with maximum humidity gradation of 10% per hour at maximum wet bulb temperature of 29°C (89°F)
Storage relative humidity	5% to 95% with a maximum humidity gradation of 10% per hour at a maximum wet bulb temperature of 38°C (100°F)
Maximum operational vibration	0.26 Grms (5 Hz – 350 Hz @ 0.0002G2/Hz) in operational orientation for 5 minutes
Maximum storage vibration	1.88 Grms with the following PSD profile (all 6 sides tested for 15 minutes each side) Frequency (Hz) G2/Hz 10 0.13 20 0.13 70 0.004 130 0.004 165 0.0018 500 0.0018
Maximum operational shock	31G half-sine shock +/-5% with pulse duration of 2.6 ms +/-10% in the operational orientation
Maximum storage shock	Square wave shock of 27G, at 235 inches/second (596.90 cm/second) velocity change (all six sides tested)
Operating altitude	-15.2 m to 3048 m (-50 to 10,000 feet) For altitudes above 2950 feet, the maximum operating temperature is derated 1°F/550 feet.
Storage altitude	–15.2 m to 10,668 m (–50 ft to 35,000 ft)
Airborne Contaminant Level Class	G1 as defined by ISA-S71.04-1985

2 Replacing Components

This chapter describes how to replace appliance components or the entire appliance.

Safety Recommendations

Follow these safety recommendations:

- Before you work on the EqualLogic FS7610 hardware, read and follow the safety instructions packaged with your system.
- Use care when moving and opening the shipping box. Leave the components packaged until you are ready to install them.
- Place the components in a protected area that has adequate airflow and is free of excessive humidity, flammable gas, and corrosion.
- You need at least two people to install the hardware. Use proper lifting and carrying techniques when unpacking and moving the components.
- Make sure each FS7610 NAS appliance is fully grounded at all times to prevent damage from electrostatic discharge.
- When handling an FS7610 NAS appliance or any of its components, use an electrostatic wrist guard or a similar form of protection. See [Using an Electrostatic Wrist Strap on page 9](#).
- Hold the hardware level with the rack when you install it.

Required Tools

The following tools are needed to replace the appliance or its components; these are not provided.

- #2 Phillips screwdriver
- Electrostatic wrist strap or other form of ESD protection

Using an Electrostatic Wrist Strap

You must use an electrostatic wrist strap to protect sensitive hardware from electrostatic discharge.

1. Connect the steel snap on the coiled cord to the stud on the elastic band. See [Figure 6](#).

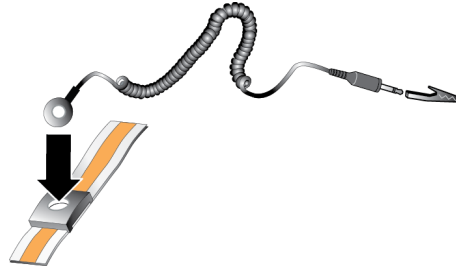
Figure 6: Using an Electrostatic Wrist Strap

2. Fit the band closely around your wrist.
3. Connect the banana plug to ground, or attach the plug to the alligator clip and connect the clip to a grounded device such as an ESD mat or the metal frame of a grounded piece of equipment.

Replacing a Controller

If a controller fails, you can replace it while the appliance is online.



Many repairs require a Dell-certified service technician. You should perform troubleshooting and simple repairs only as authorized in your product documentation or as directed by the online or telephone service and support team. Damage due to servicing that is not authorized by Dell is not covered by your warranty. Read and follow the safety instructions that came with the product.

Removing a Controller



Do not detach a controller without consulting with the owner of the group.

1. Log in to the Group Manager application or use the CLI and locate the group with the member you want to detach.
2. Select the controller that you want to detach.
3. In the Activities panel for that controller, click `Detach NAS Controller`.
After the NAS controller has detached, the power to the controller automatically turns off.
4. Disconnect all network cables.
5. Press the release latch. See callout 1 in [Figure 7](#).

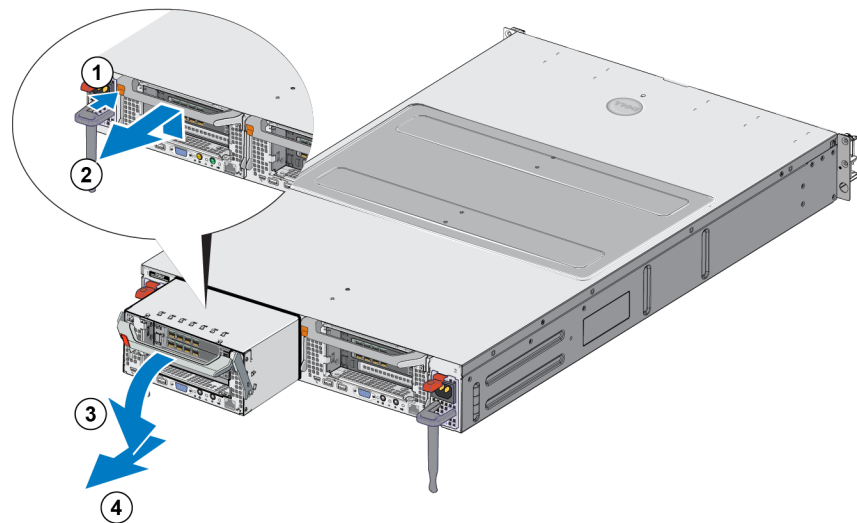
Figure 7: Removing a Controller

6. Pull the handle down and out. See callouts 2, 3, and 4 in [Figure 7](#).
7. Support the controller with two hands, and place it on an antistatic surface.

Installing a Controller

1. Correctly orient the controller with the handle on top.
2. Push the controller into the slot until you feel resistance. See callout 1 in [Figure 8](#).

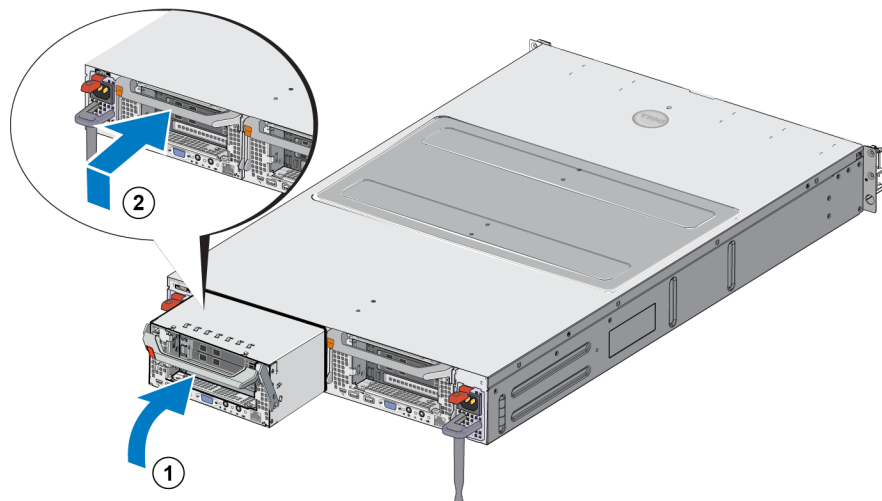
Figure 8: Installing a Controller

3. Rotate the release latch up (callout 2) and push it in until you hear it click into place.
4. Make sure you cannot pull the controller out.
5. Reconnect all the network cables.

The controller powers on automatically, which can take several minutes. (For LED states during power-on, see [Appliance Back-Panel Features on page 2](#).) After the controller is powered on, reattach the controller through the Group Manager GUI or CLI. For information, see the *Dell EqualLogic Group Manager Administrator's Manual*.

Replacing SFP+ Transceivers

 This section applies only to the 7610 SFP+ model and not to the 10GBASE-T model.

If an appliance's SFP+ (enhanced small form-factor pluggable) transceiver fails, you should take the appliance offline to replace it.

Required Items

- Replacement SFP+
- Optical transceiver extraction tool—The extraction tool helps remove SFP+ transceivers from locations where space is limited.

Removing an SFP+ Transceiver

1. Stop all system access (such as application, system I/O, or RAW device file paths).

If you are replacing or changing transceivers on a system that cannot be shut down, contact Dell Technical Support Services at eqlsupport.dell.com for additional details.

 Electronic modules can be damaged by electrostatic discharge (ESD). To prevent damage, be sure to:

- Wear an antistatic discharge strap while handling transceivers.
- Place transceivers in an antistatic bag or shipping material when transporting or storing them.

 If the SFP+ transceivers you are working with are connected to optical fiber cables, reduce the risk of injury from laser radiation and damage to equipment:

- Do not open any panels, operate controls, make adjustments, or perform procedures to a laser device other than those specified in this document.
- Do not stare into the laser beam when panels are open.

2. Label any cables that are inserted in the target transceiver.
3. Disconnect any cables that are inserted in the target transceiver.

 If you disconnect an optical fiber cable, be sure to cover the end of the cable with a protective cap to prevent damage to the cable.

4. Open the transceiver latching mechanism, using the extraction tool if necessary. (See callout 1 in [Figure 9](#)).

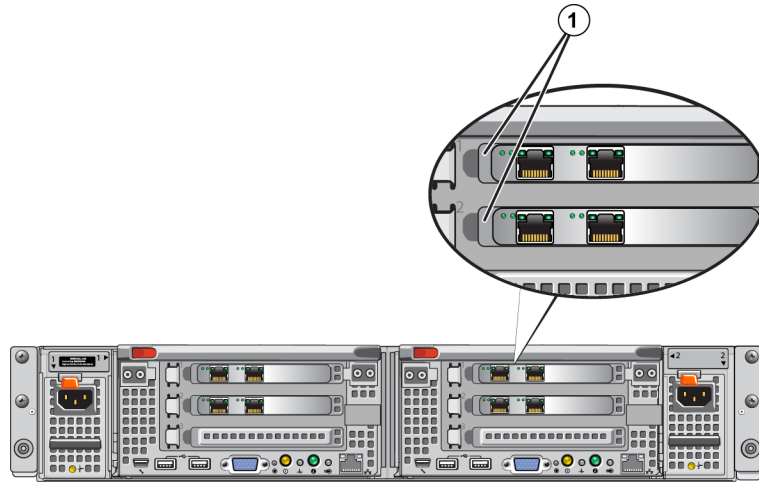
Figure 9: Removing a Transceiver

5. Pull the bail away from the controller and slide the transceiver out of the controller.

Installing an SFP+ Transceiver

1. Position the transceiver so that its key is oriented correctly to the port.
2. Gently insert the transceiver into the port until it is firmly seated and the latching mechanism clicks. If the transceiver does not slide in easily, make sure the key is in the correct position.
3. Align a network cable with the transceiver port and insert the cable. Cables are keyed so they can only be inserted correctly.
4. Bring the appliance back online to check the connections.

Replacing a Power Supply

The FS7610 NAS appliance contains two hot-swappable 717W AC power supply modules. If one supply fails, you can replace it while the appliance remains online.



Although the appliance continues to function with only one working power supply, Dell recommends that you replace a failed power supply as soon as possible. The second power supply ensures continued operation and high availability in the event of a power or power supply failure.

Removing a Power Supply

1. Disconnect the power cord from the power source, then disconnect the other end from the failed power supply. Remove the cord from the strain relief strap.
2. Press the release latch (callout 1 in [Figure 10](#)) and slide the power supply out of the appliance (callout 2).

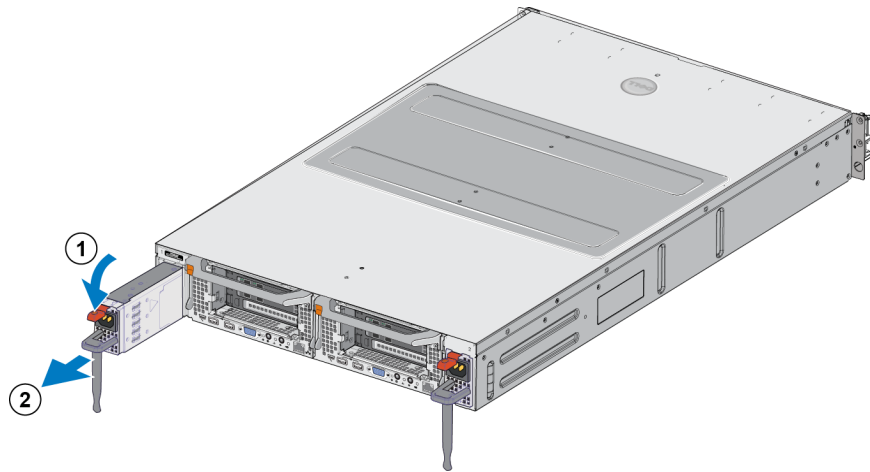
Figure 10: Removing a Power Supply

Installing a Power Supply

1. Slide the new power supply into the appliance until the release latch clicks into place. See [Figure 11](#).
2. Connect the power cord to the power supply, then connect the other end to the power source.
3. Secure the cord with the strain relief strap.
4. Make sure the power supply LED illuminates.

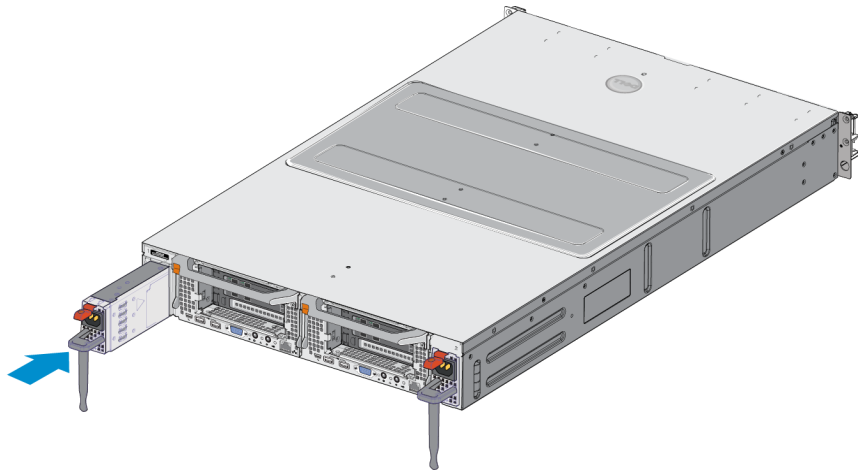
Figure 11: Installing a Power Supply

When installing a new power supply, allow several seconds for the system to recognize the power supply and determine its status. The power-supply status indicator turns green to signify that the power supply is functioning properly (see [Table 5](#)).

Removing the Bezel

If you need to access fans, or remove the bezel for any other reason, see [Figure 12](#) and follow these steps:

1. Use the key to unlock the bezel, if it is locked (callout 1).

2. Push up on the release latch on the left side of the bezel and carefully pull out the bezel from the left side of the chassis (callout 1).
3. Move the bezel to the left to disengage it from the right side of the chassis (callouts 2 and 3).

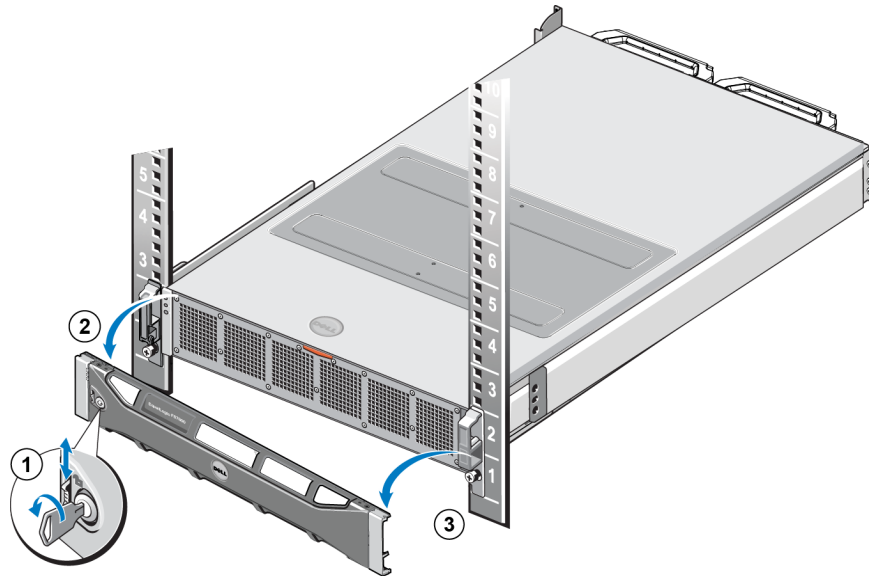
Figure 12: Removing the Bezel

Attaching the Bezel

To attach the bezel, see [Figure 13](#) and follow these steps:

1. Insert the right side of the bezel into the slot on the right side of the chassis (callout 1).
2. Push the bezel toward the left side and engage the bezel with the left side of the chassis (callout 2).
3. Use the key to lock the bezel (callout 3).

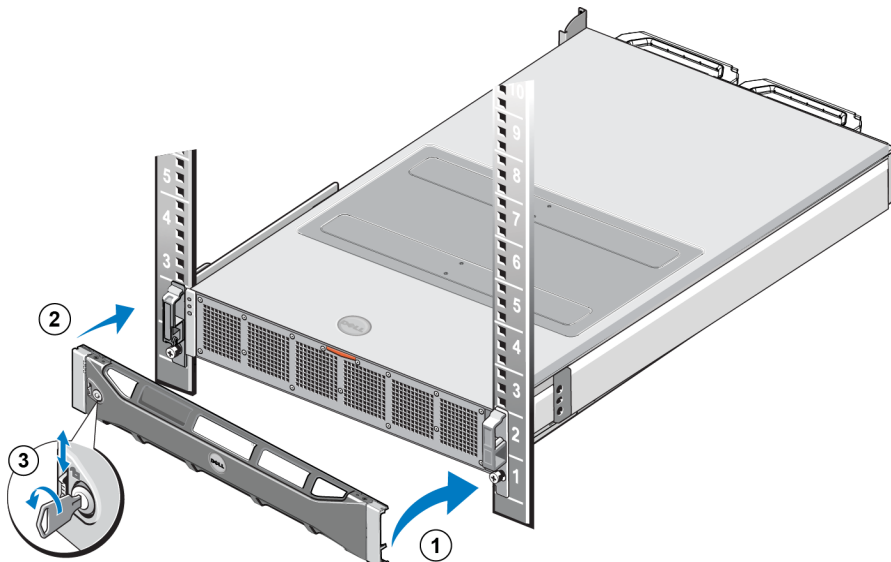
Figure 13: Attaching the Bezel

Replacing a Cooling Fan

The FS7610 NAS appliance contains six hot-swappable cooling fans. If one fan fails, you can replace it while the appliance remains online. To maintain proper cooling while the system is on, replace only one fan at a time. The procedure for replacing each fan is identical.

In the event of a problem with a particular fan, the fan number is referenced by the system's management software. Identify and replace the proper fan by referencing the fan numbers on the inside of the cooling fan access door.



Many repairs require a Dell-certified service technician. You should perform troubleshooting and simple repairs only as authorized in your product documentation or as directed by the online or telephone service and support team. Damage due to servicing that is not authorized by Dell is not covered by your warranty. Read and follow the safety instructions that came with the product.

Removing a Fan

1. If installed, remove the front bezel.
2. Press the cooling fan access door release latch (Figure 14, callout 1) to open the cooling fan access door (callout 2).



Opening or removing the NAS appliance cover when the NAS appliance is on could expose you to a risk of electric shock. Exercise care while removing or installing cooling fans.

Figure 14: Opening and Closing the Cooling Fan Access Door

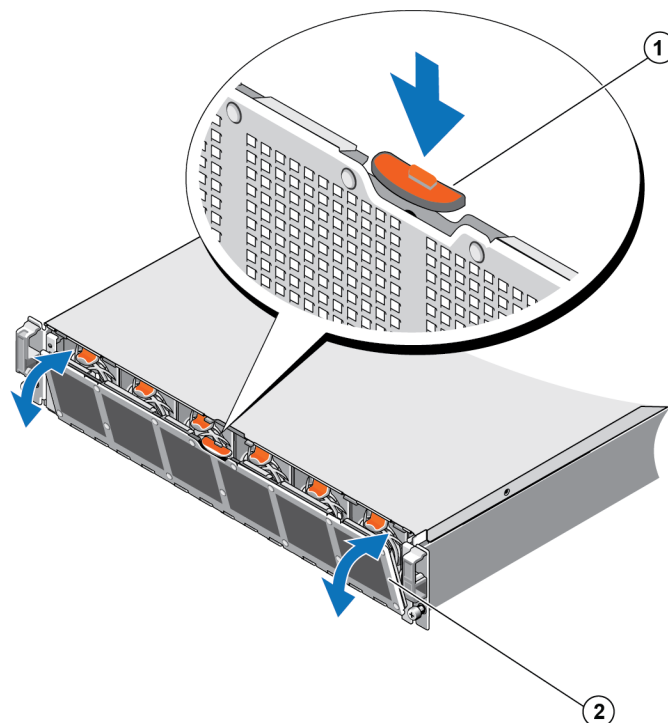

3. Press the fan release tabs (Figure 15 callout 1) and pull the cooling fan out of the NAS appliance chassis (callout 2).

Figure 15: Removing a Cooling Fan

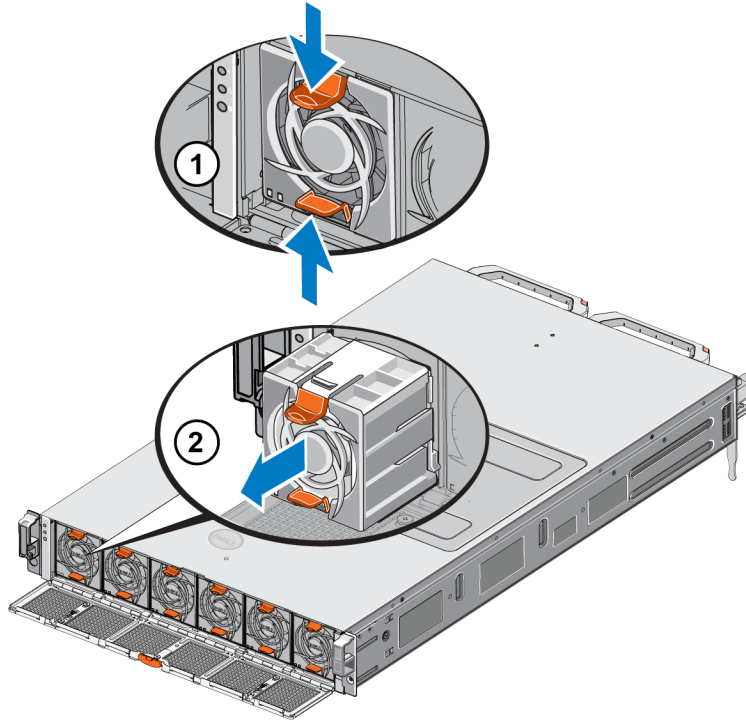

Installing a Fan

1. Align the plug at the base of the cooling fan with the connector on the system board.
2. Slide the cooling fan (Figure 16 callout 2) into the securing slots until the tabs (callout 1) lock into place.

Figure 16: Installing a Cooling Fan

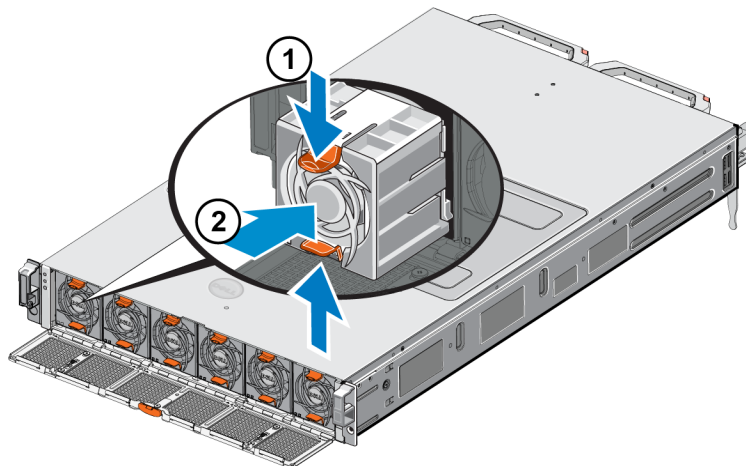

3. Close the cooling fan access door.
4. If applicable, install the front bezel.

Replacing the Appliance

If the entire NAS appliance fails, you must replace it. You will not have a functioning NAS cluster until the appliance is replaced and configured, unless you have other NAS hardware providing the services.



Removing the appliance will cause the entire NAS cluster to be lost, requiring you to rebuild the NAS cluster from scratch. Before replacing the entire NAS appliance, contact Dell technical support to assess the situation. In most cases, replacing the power supply units or control modules will resolve issues.

Removing the Appliance

1. Perform the steps for detaching the controllers from the group, turning off the power, and disconnecting the network cables in [Removing a Controller on page 10](#).
2. Remove the bezel. See [Removing the Bezel on page 14](#).
3. Loosen the thumbscrews on the left and right securing the appliance to the rack.
4. Slide the appliance out of the rack and place it on a level, antistatic surface.
5. Return the failed appliance to Dell. See [Returning Failed Hardware on page 18](#).

Installing the Appliance

See the setup poster and the *Installation and Setup Manual* that were shipped with the replacement appliance for steps on installing the system into the rack and configuring the appliance.

Returning Failed Hardware

If you receive a replacement part from your FS Series support provider, return the failed hardware in the packaging in which the replacement part was shipped. Returning hardware in unauthorized packaging could void your warranty.

Contact your FS Series support provider for information about returning hardware.

3 What to Do Next

You can customize the NAS cluster and create additional containers, CIFS shares, and NFS exports. You can also use snapshots to protect NAS container data.

NAS Cluster Documentation

The *Dell EqualLogic Group Manager Administrator's Manual* provides detailed NAS cluster information. The Group Manager online help describes how to use the Group Manager graphical user interface (GUI) to manage a NAS cluster.

The *Dell EqualLogic Group Manager Administrator's Manual* and the Group Manager command line interface (CLI) help describe how to use the CLI to manage a NAS cluster.

For the latest information about NAS clusters, see the Dell EqualLogic customer support website.

Appendix A: NOM Information (Mexico Only)

The information provided in [Table 7](#) applies to the device described in this document in compliance with the requirements of the official Mexican standards (NOM).

Table 7: NOM Information for Mexico

Norma Oficial Mexicana	
Importer	Dell México S.A. de C.V. Paseo de la Reforma 2620 -- 11° Piso Col. Lomas Altas 11950 México, D.F.
Model number: E02T	Supply voltage: 100–240 VAC Frequency: 50/60 Hz Current consumption: 10–6.5 A X2 (X#), # = Maximum number of power supplies per system

Glossary

Understanding terminology related to a NAS cluster will help you successfully deploy, manage, and maintain your unified storage environment.

Dell FluidFS

High-performance, scalable file system that is configured on storage space.

group

See [PS Series group](#).

group IP address

Highly available IP address that iSCSI initiators use to access iSCSI targets hosted by a PS Series group.

IPMI

Intelligent Platform Management Interface.

NAS controller

One of a pair of hardware components running file sharing software, and integrated into a NAS appliance (for example, an FS7610).

NAS container

Virtual container that consumes space in the NAS reserve. Administrators can create CIFS shares and NFS exports on a NAS container and share them with authorized users. A NAS cluster supports multiple NAS containers.

NAS appliance

Dell hardware that contains two controllers that must be paired together when configured into a NAS cluster. After an appliance is configured, it becomes a NAS member.

NAS member

A NAS appliance that has been configured into a NAS cluster. The NAS member contains two NAS controllers that must be managed as a pair.

NAS reserve

Storage pool space on a PS Series group allocated to a NAS cluster for storing internal data and user data configured with Dell FluidFS.

NAS cluster

Provides highly available and scalable NAS storage by using a PS Series group and at least one EqualLogic NAS appliance, configured and managed through Group Manager.

NAS cluster IP address

Highly available IP address that clients use to access CIFS shares and NFS exports hosted by a NAS cluster.

NAS cluster management IP address

IP address used for internal operations between NAS members and the PS Series group.

PS Series group

One or more PS Series storage arrays configured on a network, accessed through a single IP address and managed as a single system.

Glossary: –

A

appliance
dimensions 7
front and back panels 1-2
specifications 6
weight 7

B

back-panel features 2
back-panel LEDs 3
backup power supply (BPS) 3, 5
bezel
attaching 15
key lock on controller 15
removing 14

C

controller
location on back panel 3
cooling fan
see fan 16

E

electrostatic discharge
protection 9

F

fan
installing 17
removing 16
replacing 16
front-panel features 1
front-panel LEDs 1
front and back panels 1-2

G

Group Manager CLI 19
Group Manager GUI 19

I

installation
safety precautions 9

L

LEDs
back panel 3
controller 5
front panel 1

N

NAS cluster
documentation 19
post-configuration tasks 19

P

power
turning on the controller 5
power supply unit (PSU) 3

R

rack mount
tools required 6, 9

S

safety recommendations 9
service tag 1
service tag card 1
snapshots 19
specifications
controller 6

T

technical specifications
controllers 6
troubleshooting
Controller LEDs 5

