



# **EqualLogic FS7500 Controller**

## **Hardware Maintenance**

PS Series Firmware Version 5.1

Copyright 2011 Dell, Inc. All rights reserved.

Dell is a trademark of Dell, Inc.

EqualLogic is a registered trademark.

All trademarks and registered trademarks mentioned herein are the property of their respective owners.

Information in this document is subject to change without notice.

Reproduction in any manner whatsoever without the written permission of Dell is strictly forbidden.

June 2011

Part Number: 110-6070 Rev. R1

# Table of Contents

---

<b>Preface</b> .....	<b>v</b>
Audience .....	v
Organization .....	v
Technical Support and Customer Service .....	vi
Online Services .....	vi
Warranty Information .....	vi
<b>1 Basic Controller Information</b> .....	<b>1-1</b>
FS7500 Controller Components .....	1-1
FS7500 Controller Front Panel .....	1-2
LCD Screen and Control Keys .....	1-2
Drive Status Indicator LEDs .....	1-3
FS7500 Controller Back Panel .....	1-4
Network Status LEDs .....	1-6
<b>2 Installing System Components</b> .....	<b>2-1</b>
Safety Recommendations .....	2-1
Recommended Tools .....	2-1
Required Hardware That Is Not Supplied .....	2-2
Hardware Protection .....	2-2
Using an Electrostatic Wrist Strap .....	2-2
Removing and Reinstalling the Controller Bezel .....	2-3
Removing the Controller Bezel .....	2-3
Attaching the Controller Bezel .....	2-4
BPS and Power Connections .....	2-5
Connecting a Controller to a Power Source and a BPS Power Module .....	2-5
Network Configuration Overview .....	2-6
Controller Network Interface Ports .....	2-6
Network Connection Requirements and Recommendations .....	2-7
Steps for Connecting Network Cables .....	2-8
Determining the Correct Number of Network Cables .....	2-8
Connecting SAN and Internal Network Cables .....	2-10
Connecting the Client Network Cables .....	2-11
Managing the Controller Cables .....	2-11
Managing Cables in a Standard Installation .....	2-11
Routing the Power Cables Through the Strain Relief Straps .....	2-12
Bundling the Network and Power Cables .....	2-13
Securing the Network and Power Cable Bundles to the Rails .....	2-13
Steps for Managing Cables Using a Service Loop .....	2-15
Routing the Power Cables Through the Strain Relief Straps .....	2-16
Extending the Controller into Service Position .....	2-16
Bundling Network and Power Cables .....	2-17
Turning On Power to a Controller .....	2-17
Powering Down the Controller .....	2-17
<b>3 Maintaining System Components</b> .....	<b>3-1</b>
Removing and Replacing a Controller .....	3-1
Uninstalling the Controller from the Rack .....	3-1

- Installing the Replacement Controller .....3-2
- Attaching the Cables .....3-2
- Turning on the Power.....3-2
- Obtaining the Service Tag.....3-2
- Attach the Controller to the NAS Node Pair.....3-2
- Removing and Installing a Disk Drive .....3-2
  - Disk Drive Handling Requirements .....3-2
  - Removing a Drive Blank.....3-3
  - Installing a Drive Blank .....3-4
  - Removing a Hot-Swap Disk Drive .....3-5
  - Installing a Hot-Swap Disk Drive .....3-6
- Removing and Installing a Power Supply .....3-7
  - Removing a Power Supply .....3-7
  - Installing a Power Supply .....3-8
- Power Supply LED Status .....3-9
- 4 Troubleshooting .....4-1**
  - Obtaining the Controller Service Tag.....4-1
  - Displaying the Service Tag .....4-1
- 5 What to Do Next.....5-1**
- A FS7500 Controller Technical Specifications.....A-1**
  - FS7500 Controller Technical Specifications .....A-1
  - .....A-1
- Index.....Index-1**

## Preface

---

This manual describes how to maintain and troubleshoot the customer replaceable components of the EqualLogic FS7500 Controller.

With the addition of the EqualLogic FS7500, Dell provides a unified view of both block storage and a high-performance, scalable NAS (Network Attached Storage) service.

- Allows you to configure a NAS service and manage it through the EqualLogic Group Manager.
- Lets you create multiple NAS file systems in the NAS service.
- On each file system, lets you create multiple CIFS shares and NFS exports.
- Lets you use snapshots to protect file system data.

## Audience

This manual is designed for the administrators responsible for installing or maintaining EqualLogic FS7500 hardware. Administrators are *not* required to have extensive network or storage system experience. However, it may be useful to understand:

- Basic networking concepts
- Current network environment
- User disk storage requirements
- RAID configurations
- Disk storage management

Note: Although this manual provides examples of using an EqualLogic FS7500 in some common network configurations, detailed information about setting up a network is beyond its scope.

## Organization

This manual is organized as follows:

- Chapter 1, *Basic Controller Information*, describes the location of the customer replaceable components in the FS7500 controller. It also includes power on and power off information.
- Chapter 2, *Installing System Components*, outlines the procedures for removing and replacing components.
- Chapter 3, *Maintaining System Components*, describes how to replace components.
- Chapter 4, *Troubleshooting*, discusses ways to diagnose and fix some problems.
- Chapter 5, *What to Do Next*, lists additional sources of useful information about the FS7500, its hardware components, and its software.
- Appendix A, *FS7500 Controller Technical Specifications*, lists specifications for the FS7500 controller.

## Technical Support and Customer Service

Dell's support service is available to answer your questions about FS Series systems. If you have an Express Service Code, have it ready when you call. The code helps Dell's automated-support telephone system direct your call more efficiently.

### Contacting Dell

Dell provides several online and telephone-based support and service options. Availability varies by country and product, and some services might not be available in your area.

For customers in the United States, call 800-945-3355.

**Note:** If you do not have access to an Internet connection, contact information is printed on your invoice, packing slip, bill, or Dell product catalog.

Use the following procedure to contact Dell for sales, technical support, or customer service issues:

1. Visit [support.dell.com](http://support.dell.com) or the Dell support URL specified in information provided with the Dell product.
2. Select your locale. Use the locale menu or click on the link that specifies your country or region.
3. Select the required service. Click the "Contact Us" link, or select the Dell support service from the list of services provided.
4. Choose your preferred method of contacting Dell support, such as e-mail or telephone.

### Online Services

You can learn about Dell products and services using the following procedure:

1. Visit [www.dell.com](http://www.dell.com) (or the URL specified in any Dell product information).
2. Use the locale menu or click on the link that specifies your country or region.

### Warranty Information

The warranty information for your system is included in the shipping box. For information about registering a warranty, visit [support.dell.com/EqualLogic](http://support.dell.com/EqualLogic).

# 1 Basic Controller Information

This chapter includes information about the location and basic operation of the components in a FS7500 controller. The chapter also contains power on and off operations, and how to return failed components.

## FS7500 Controller Components

Figure 1-1 shows the FS7500 controller components. The only customer replaceable components in the FS7500 are the bezel, the hard drives, and the power supplies. For more information about customer replaceable components, see Chapter 2, *Installing System Components*.

**Figure 1-1: FS7500 Controller Components**

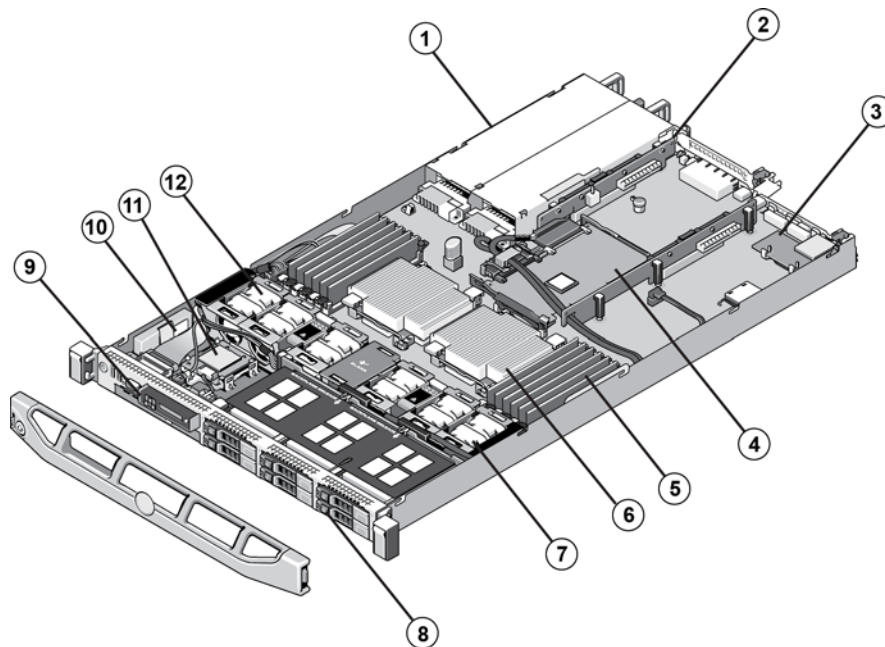

**Table 1-1: FS7500 Controller Components**

Number	Description
1	Power supply bays (2)
2	Expansion card riser
3	DRAC card
4	Integrated storage controller card
5	Memory modules (12)
6	Processor and heat sink (2)
7	SAS backplane
8	Hard drives (6)
9	Optical drive
10	RAID battery
11	Internal SD module

**Table 1-1: FS7500 Controller Components**

Number	Description
12	Fans (5 or 6)

## FS7500 Controller Front Panel

Figure 1-2 shows the front panel of the FS7500 Controller.

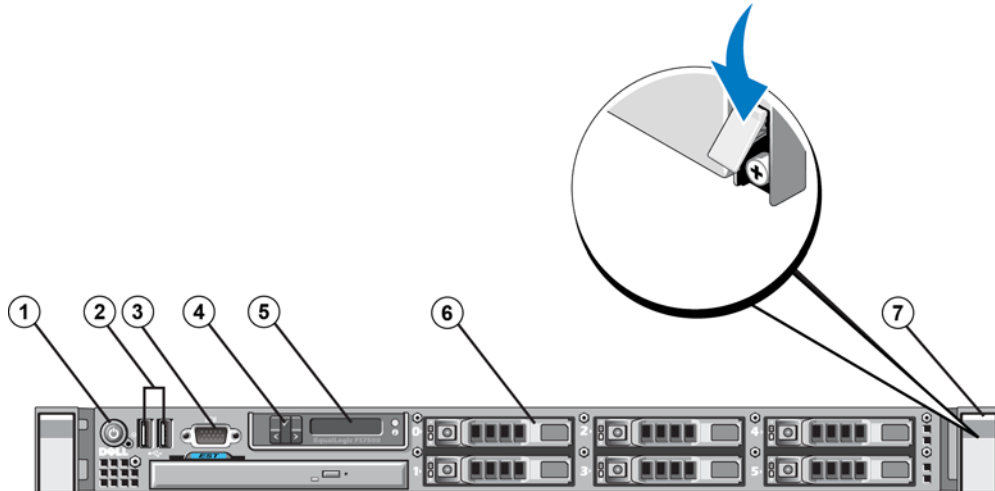
**Figure 1-2: FS7500 Controller Front Panel****Table 1-2: FS7500 Controller Front Panel Components**

Number	Component
1	Power button
2	USB ports
3	Video port
4	LCD screen control keys
5	LCD screen
6	Hard drives (6)
4	Retaining Screws (under latch)

## LCD Screen and Control Keys

The LCD screen control keys display useful information about the FS7500 Controller, including the service tag. For more information about the service tag, refer to Chapter 4.

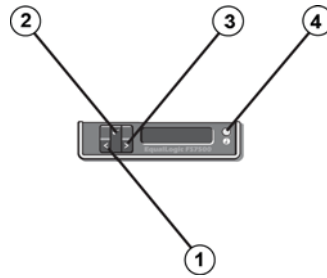

**Figure 1-3: LCD Screen and Control Keys****Table 1-3: Control Key Functions**

Number	Description
1	Left button. Moves the cursor backward in one-step increments.
2	Select button. Selects the choice indicated by the cursor.
3	Right button. Moves the cursor forward in one-step increments. Also controls scrolling speed.
4	System ID button. Toggles the service tag display on and off.

The LCD screen is backlit in blue when the system is operating normally. When the system needs attention, the screen is backlit in amber. When the system is in standby mode, the LCD backlight will switch off after 5 minutes of inactivity. It can be turned back on by pressing the Select button on the LCD panel.

## Drive Status Indicator LEDs

Each hard drive in the FS7500 Controller has two status indicator LEDs. One LED displays whether the hard drive is active (powered on). The other LED displays the current operational state of the drive. Figure 1-4 shows the location of the two LEDs, and Table 1-4 describes their behavior.

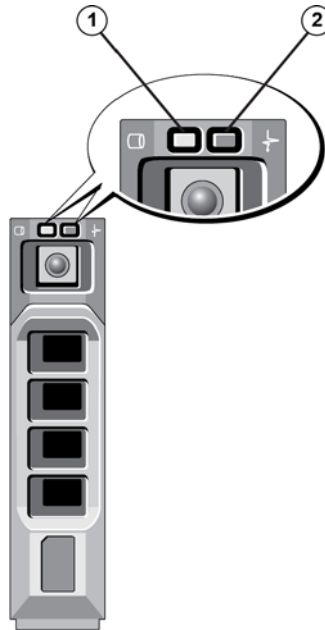
**Figure 1-4: Drive Status Indicator LEDs****Table 1-4: Drive Status Indicator LEDs**

Number	Description
1	Drive activity indicator (green)
2	Drive status indicator (green and amber)

Table 1-5 shows the different LED behavior patterns of the drive status indicator LED and the corresponding state of the hard drive.

**Table 1-5: Drive Status Indicator LED States**

LED Blinking Pattern	Description
Blinking green, 2x per second	Identifying drive or preparing for removal
Off (not lit)	Drive ready for insertion or removal  <b>Note:</b> The drive status indicator LED remains off until all hard drives are installed after system power is applied. Drives are not ready for insertion or removal during this time.
Blinks green, amber, then off	Drive predicted failure
Blinking amber, 4x per second	Drive failed
Slow blinking green	Drive rebuilding
Steady green	Drive online

## FS7500 Controller Back Panel

Figure 1-5 shows the back panel of the FS7500 Controller.

**Figure 1-5: FS7500 Controller Back Panel**

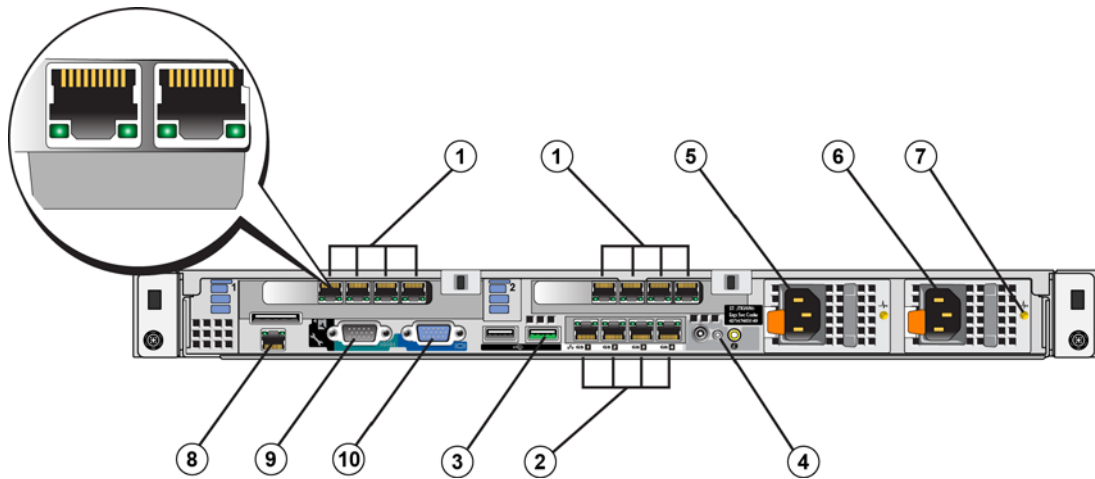
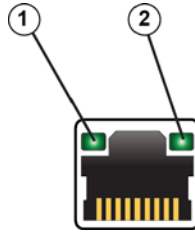

**Table 1-6: FS7500 Controller Back Panel Components**

Number	Component
1	Internal network and SAN network connectors
2	Client network connections
3	USB port (to BPS)
4	System power-on status LED
5	C14 power connector (to BPS)
6	C14 power connector (to AC power source)
7	Power supply status LED
8	IPMI port
9	RS-232 port
10	Video port

## Network Status LEDs

The internal and SAN network connectors have two LEDs that indicate the status of the network connections.



**Table 1-7: Network Status LEDs**

Number	Component
1	Network on/off LED. Shows steady green when on.
2	Network send/receive LED. Flashes green when network traffic is OK. Flashes amber when a network issue is detected.

## 2 Installing System Components

---

### Safety Recommendations

Follow these safety recommendations when installing or reinstalling FS7500 components:

- Before you install the EqualLogic FS7500 hardware, read and follow the safety instructions packaged with your system.
- Individuals with rack mounting experience should install EqualLogic FS7500 hardware in a rack.
- Use care when moving and opening the cartons. Leave the components packaged until you are ready to install them.
- Place the components in a protected area that has adequate airflow and is free of humidity, flammable gas, and corrosion.
- You need at least two people to install the hardware. Use proper lifting and carrying techniques when unpacking and moving the components.
- Make sure each FS7500 Controller is fully grounded at all times to prevent damage from electrostatic discharge.
- When handling an FS7500 Controller, use the electrostatic wrist guard shipped with the controller or a similar form of protection. See *Hardware Protection* on page 2-2.
- Hold the hardware level with the rack when you install it.

### Recommended Tools

You need the following tools to install and maintain the components in the EqualLogic FS7500 controller:

- Key to the system keylock
- #1 and #2 Phillips screwdrivers
- Electrostatic wrist strap

## Required Hardware That Is Not Supplied

You must provide additional hardware that is specific to your environment and not included in the shipping box. See Table 2-1.

**Table 2-1: Required Hardware – Not Supplied**

Component	Description
Network cables	<p>Connects FS7500 Controller network ports to a network switch.</p> <p>Use Category 5E or Category 6 cables with RJ45 connectors. Use Category 5 cables only if they adhere to the TIA/EIA TSB95 standard.</p> <p>For each FS7500 Controller, you need 5 (minimum) or 13 (recommended) network cables (that is, 5x2 or 13x2 cables for a complete EqualLogic FS7500 installation). See the EqualLogic FS7500 <i>Installation and Setup</i> manual for more information.</p>
1GE network switch	<p>Connects devices to a network. Multiple switch stacks are recommended. See <i>Network Connection Requirements and Recommendations</i> on page 2-7.</p>

## Hardware Protection

When not installed in a rack, a FS7500 Controller must be in its original packaging or placed on a sturdy surface that is protected from electrostatic discharge.

When handling a FS7500 Controller, make sure you use the electrostatic wrist strap that is shipped with the controller or a similar form of protection.

## Using an Electrostatic Wrist Strap

You must protect sensitive hardware from electrostatic discharge.

To use an electrostatic wrist strap:

1. Connect the steel snap on the coil cord to the stud on the elastic band. See Figure 2-1.

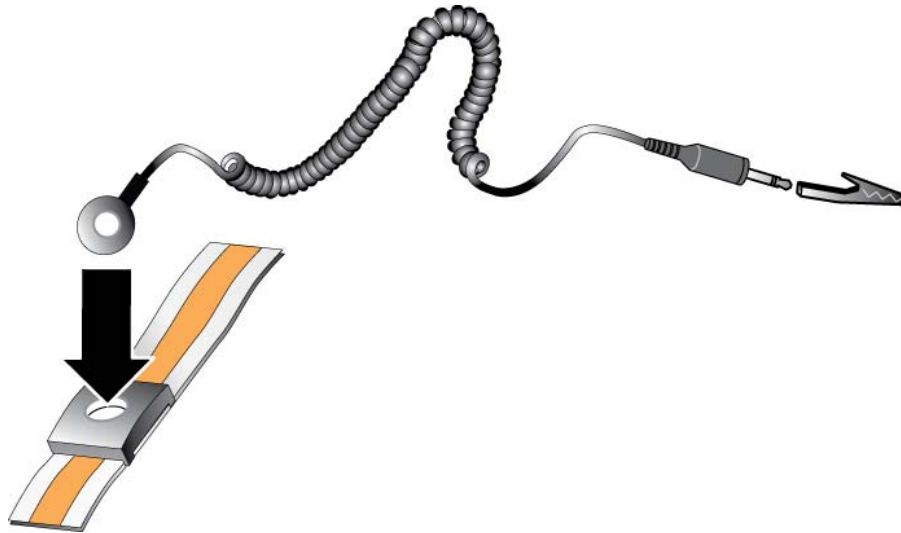
**Figure 2-1: Using an Electrostatic Wrist Strap**

- 2 Fit the band closely around your wrist.
- 3 Connect the banana plug to ground, or attach the plug to the alligator clip and connect the clip to a grounded device such as an ESD mat or the metal frame of a grounded piece of equipment.

## Removing and Reinstalling the Controller Bezel

### Removing the Controller Bezel

To remove the FS7500 Controller bezel, see Figure 2-2 and follow these steps:

1. Use the key to unlock the bezel, if it is locked.
2. Push up on the release latch on the left side of the bezel and carefully pull out the bezel from the left side of the controller.
3. Holding the bezel, move it to the left to disengage the bezel from the right side of the controller.

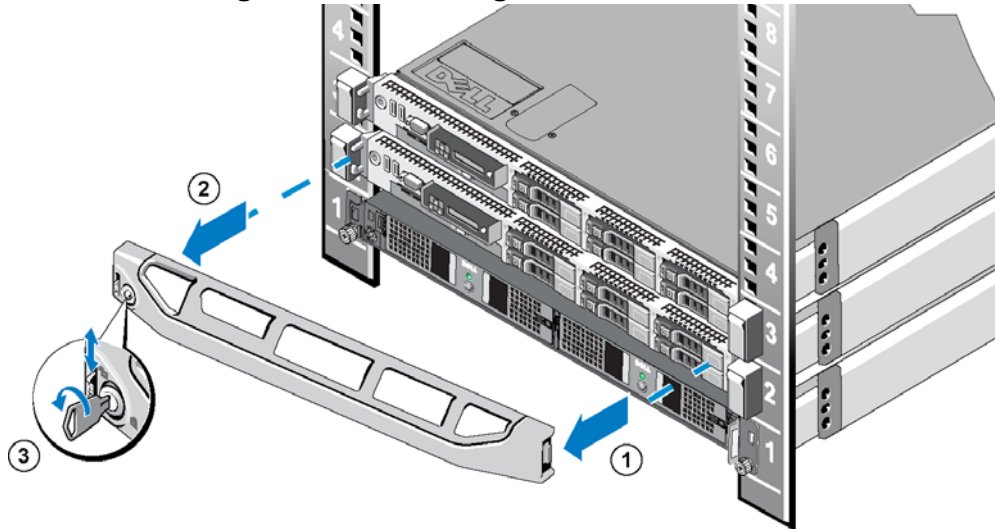
**Figure 2-2: Removing the Controller Bezel**

## Attaching the Controller Bezel

To attach the controller bezel, see Figure 2-3 and follow these steps:

1. Insert the right side of the bezel into the slot on the right side of the controller. (Callout 1)
2. Push the bezel toward the left side and engage the bezel with the left side of the controller chassis. (Callout 2)
3. Use key to lock the bezel. (Callout 3)

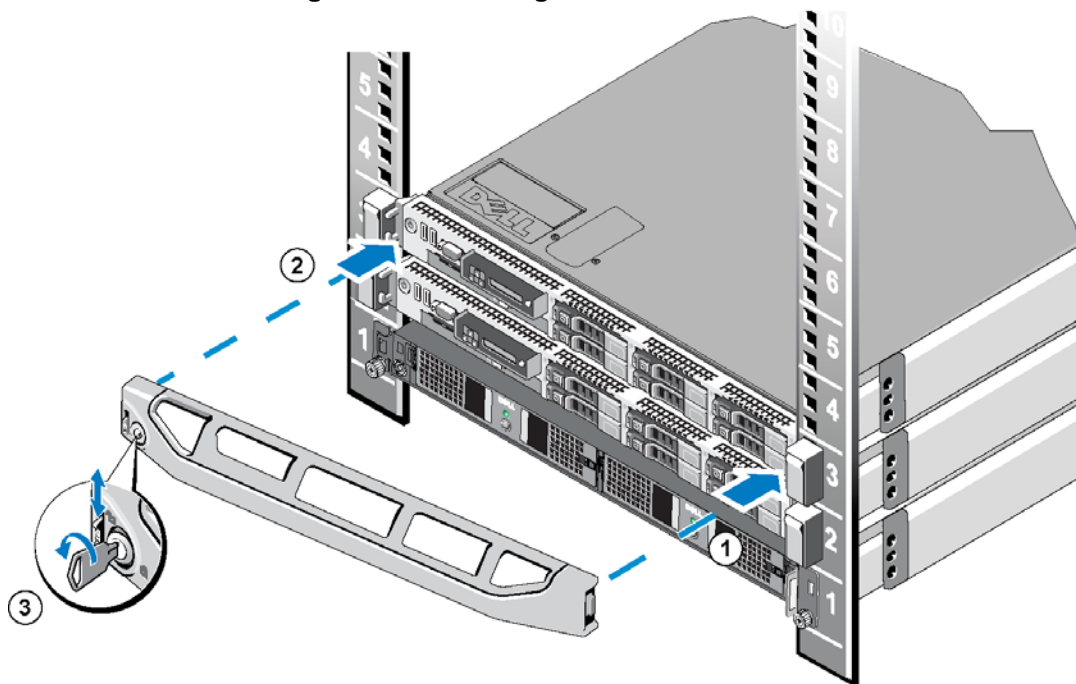
**Figure 2-3: Attaching the Controller Bezel**



## BPS and Power Connections

Each FS7500 Controller is connected to a different BPS power module and a different source of power. You can then verify that each controller is operational.

Figure 2-4 shows the two controllers and the BPS properly connected.

**Figure 2-4: Complete EqualLogic FS7500 Power Connections**

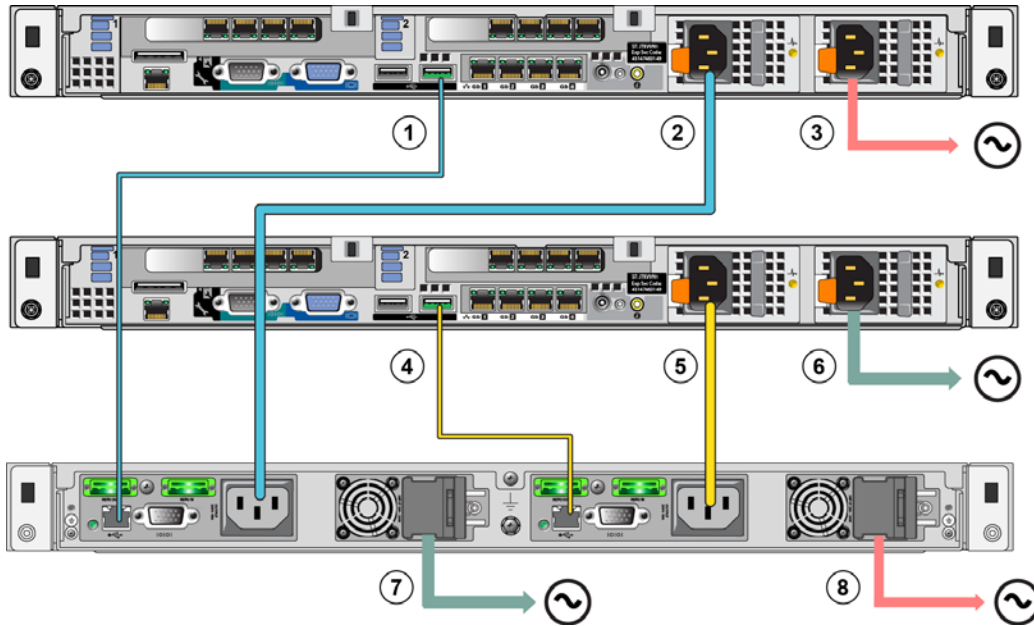

**Table 2-2: EqualLogic FS7500 Power Connections**

Number	Description
1	USB connection from Controller 1 to BPS power module 1
2	Power connection from Controller 1 to BPS power module 1
3	Power connection from Controller 1 to Power Source 1
4	USB connection from Controller 2 to BPS power module 2
5	Power connection from Controller 2 to BPS power module 2
6	Power connection from Controller 2 to Power Source 2
7	Power connection from BPS to Power Source 2
8	Power connection from BPS to Power Source 1

### Connecting a Controller to a Power Source and a BPS Power Module

To connect a controller to a power source and a BPS power module, see Figure 2-4 and Figure and follow these steps:

1. Connect the A connector on the USB cable to the USB port on the controller (located to the left of the bottom network interface card) and connect the B connector to the USB port on a BPS power module (callout number 1 in Figure 2-4).

2. Use a power cable with a C13 connector and a C14 connector to connect the controller's left power supply to the output receptacle on the same BPS power module to which you connected the USB cable in the previous step (see callout 2 in Figure 2-4). Use the cable strain relief strap on the power supply to secure the power cable to the controller chassis.
3. Using a power cable with a C13 connector and a connector that fits the receptacle of your power source, connect the controller's right power supply to a power source (callout 3 in Figure 2-4). Use the cable strain relief strap on the power supply to secure the power cable to the controller chassis.

For high availability, be sure the power source is not the same as the power source to which the BPS power module is connected.

4. Repeat the three steps to connect the second controller to the other power module on the BPS.

## Network Configuration Overview

The EqualLogic FS7500 requires three networks:

- **Client network** – Used for client access to the NFS exports and CIFS shares hosted by the NAS service. For each controller, at a minimum, you need one client network connection. The recommended configuration is four client network connections for each controller.
- **SAN network** – Used for access between the PS Series group (SAN) and the NAS nodes. For each controller, at a minimum, you need one SAN network connection. The recommended configuration is four SAN network connections for each controller.
- **Internal network** – Used for communication between the NAS nodes. For each controller, you need a minimum of three internal network connections. The recommended configuration is five internal network connections for each controller.

For security reasons, the internal network is usually a private network and the client network must be separate from the SAN and from the internal network.

An FS7500 Controller has three four-port NICs, plus a single network interface port in the lower left corner of the back panel. These ports are dedicated to specific networks:

- The ports in the two top NICs and the single port are only for SAN and internal network connections.
- The ports in the bottom NIC are only for client network connections.

The FS7500 controller comes with an attached quick-reference tag that shows the cable connections.

## Controller Network Interface Ports

Figure 2-5 shows the network interface ports on the controller.

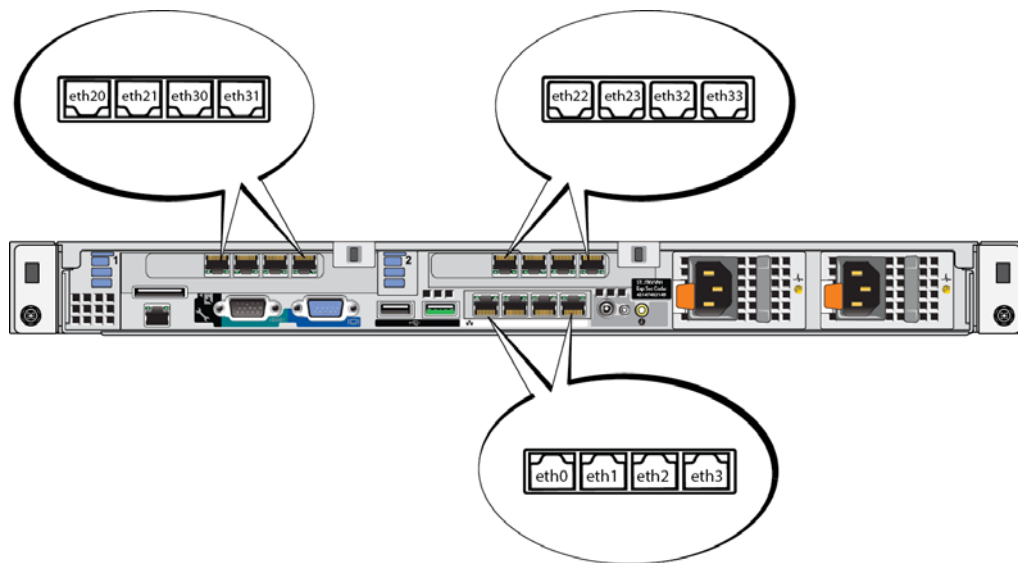
**Figure 2-5: FS7500 Controller Network Interface Ports**

The network interface ports connect to the following:

- eth20 - eth23: Internal network
- eth30 - eth33: SAN
- eth0 - eth3: Client

## Network Connection Requirements and Recommendations

At a minimum, you can connect all the network ports in an EqualLogic FS7500 to the same physical switch. However, this configuration is appropriate only for demonstration or testing purposes because the network switch is a single point of failure. Dell recommends that you use a highly-available network switch configuration for the client, SAN, and internal network connections.

Ideally, you want a network switch configuration in which a switch failure does not disrupt the availability of the NAS service. This means that no single switch should have all the client, SAN, or internal network connections.

Network connection requirements and recommendations for each FS7500 Controller are as follows:

- A switched 1GE network is recommended.
- You need either 5 times as many network cables as you have controllers (minimum network configuration) or 13 times as many network cables as you have controllers. (recommended network configuration) That is, you need 5 or 13 cables for each FS7500 Controller.
- Connect the IPMI port to the internal network.
- Connect the two internal network ports on each network interface card (NIC) to different switches.

- Connect the two SAN network ports on each NIC to different switches.
- Connect two client network ports on the bottom NIC to one switch, and connect the other two client network ports to a different switch.
- The following recommendations apply to the SAN network:
  - Flow Control enabled on switches and network interfaces
  - Unicast storm control disabled on switches
  - Jumbo Frames should be enabled.
  - VLANs may be used, but are not required.

## Steps for Connecting Network Cables

To connect network cables to a FS7500 Controller, follow these steps:

1. Obtain the correct number of network cables. For each controller, you need either 5 (minimum network configuration) or 13 (recommended network configuration) network cables. This means that you will need a total of 5x2 (10) or 13x2 (26) cables for both controllers. See *EqualLogic FS7500 Network Configuration – Minimum* on page 2-10.
2. Connect the cables for the SAN and internal network connections. See *Connecting SAN and Internal Network Cables* on page 2-10.
3. Connect the cables for the client network connections. See *Connecting the Client Network Cables* on page 2-11.
4. Use the cable management system to organize the network cables. See *Managing the Controller Cables* on page 2-11.

Figure 2-6 shows the recommended EqualLogic FS7500 network configuration. Figure 2-7 shows the minimum network configuration, and Table 2-3 describes the components in that configuration. Note that BPS and power connections are not shown.

## Determining the Correct Number of Network Cables

The number of cables you need depends on the desired number of client, SAN, and internal network connections:

- Recommended configuration. The recommended configuration provides the highest availability and performance. For each controller, you need 13 cables. This provides five internal network connections, four SAN network connections, and four client network connections. See Figure 2-6 for an example.
- Minimum configuration. For each controller, you need five network cables. This provides three internal network connections, one SAN network connection, and one client network connection. See Figure 2-7 for an example.

**Note:** The recommended configuration provides the best performance and availability.

**Figure 2-6: EqualLogic FS7500 Network Configuration – Recommended**

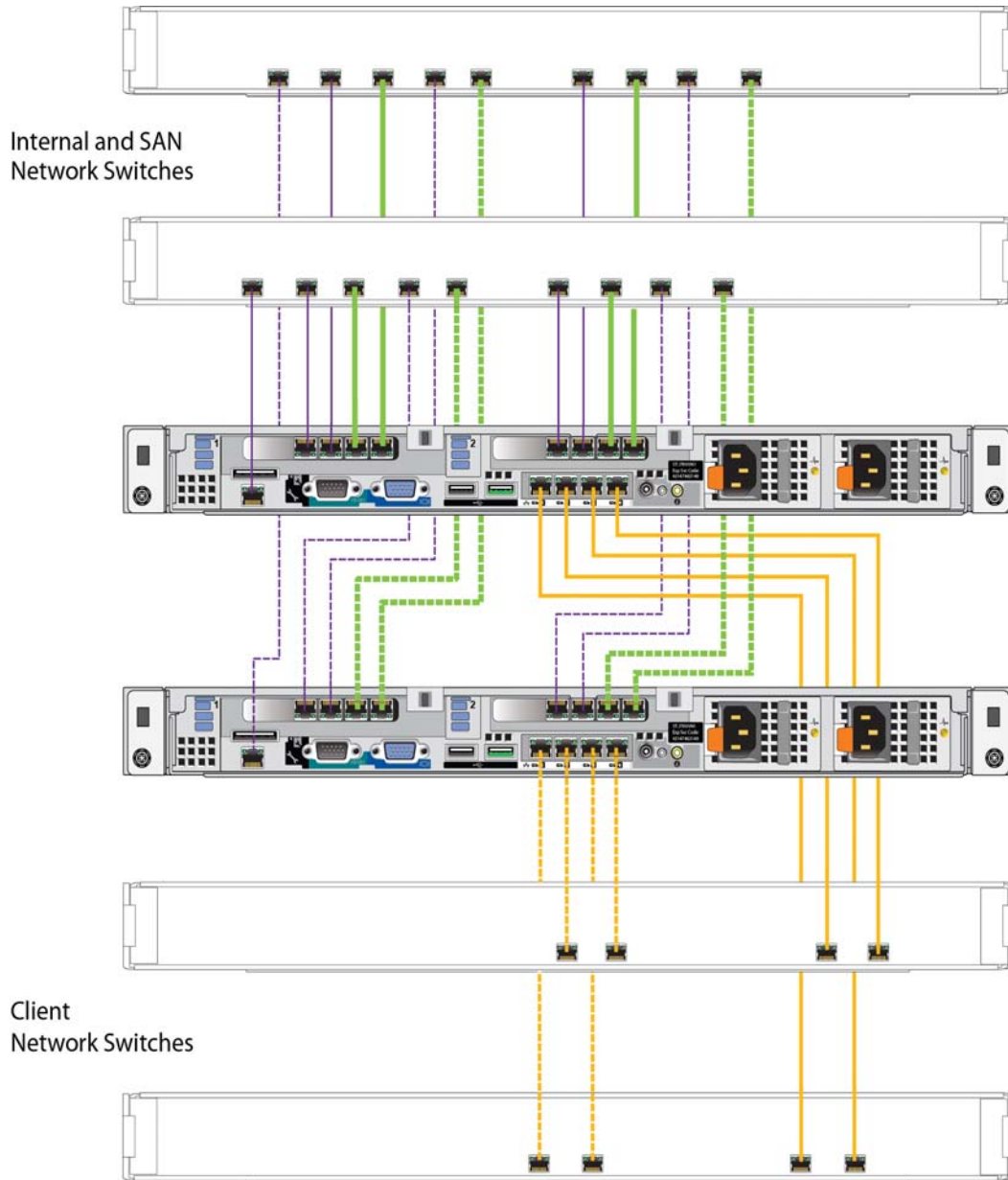

Internal Network: Thin width (purple)  
Client Network: Medium width (yellow)  
SAN connections: Thick width (green)

**Figure 2-7: EqualLogic FS7500 Network Configuration – Minimum**

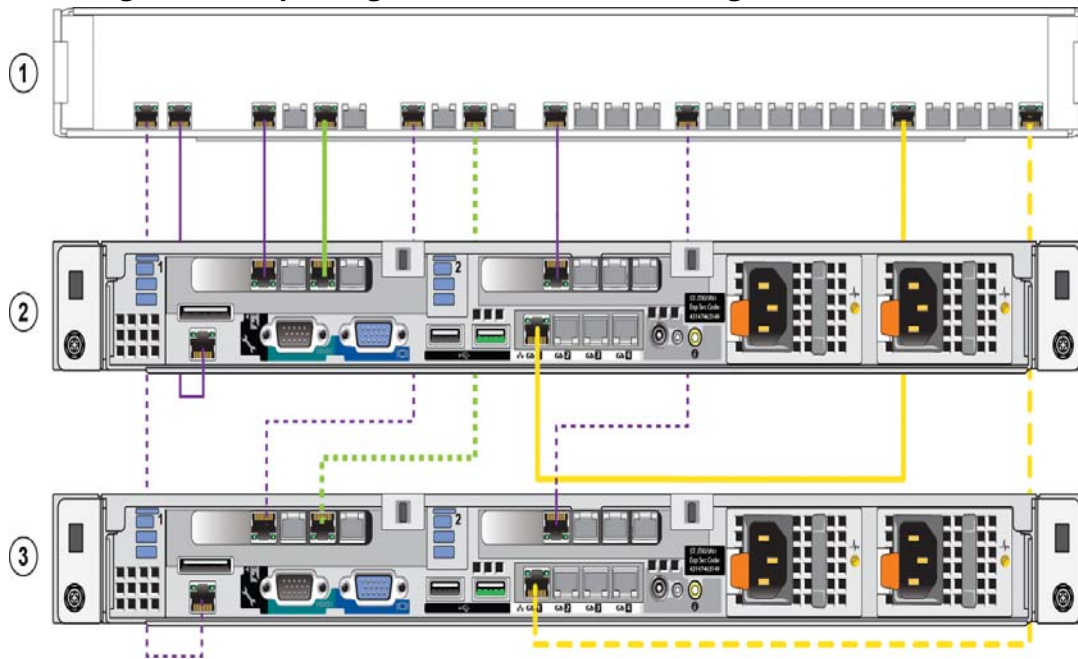

**Table 2-3: Minimum Network Configuration Component Descriptions**

Callout	Description
1	Switch stack (used for both client and internal connections)
2, 3	FS7500 Controllers

## Connecting SAN and Internal Network Cables

For the recommended configuration, see Figure 2-6. For each controller, use nine network cables to make the following controller connections to the two switch stacks:

- All the ports on the two top network interface cards.
- Single port in the lower-left corner of the controller.

**Note:** Be sure to distribute the internal network and SAN connections across the two switches for high availability.

For the minimum configuration, see Figure 2-7. For each controller, use four network cables to make the following controller connections to the same switch stack:

- First and third port in the top-left network interface card.
- First port in the top-right network interface card.
- Single port in the lower-left corner of the controller.

## Connecting the Client Network Cables

For the recommended configuration, see Figure 2-6. For each controller, use four network cables to connect all the ports on the bottom network interface card to the two switches. Distributing the connections across both switches ensures high availability.

For the minimum configuration, see Figure 2-7. For each controller, use one network cable to connect the first port in the bottom network interface card to the switch stack.

## Managing the Controller Cables

There are three main methods of managing the controller cables in the EqualLogic FS7500. The three methods differ in how the controller cables are routed and secured. The three methods are:

- Cabling the FS7500 installed in sliding rails. This is the standard installation as described in the EqualLogic FS7500 *Installation and Setup Guide*, using the rails provided in the shipping box. The cable connections are described in *Steps for Connecting Network Cables* on page 2-8.
- Adding a service loop to the FS7500 controller installed in the provided rails. A service loop is an extra length of cable between the rear of the controller and the rack. The additional cable allows you to slide the controller forward on the rails for servicing without having to disconnect the cables and power cables.
- Cabling the FS7500 controller installed in static rails. This method requires a different set of rails that must be ordered separately. Appendix A in the EqualLogic FS7500 *Installation and Setup Guide* describes how to manage cables on controllers that are installed in static rails.

For more information about routing controller cables, see the Dell white paper *Dell Best Practices Guide for Rack Enclosures*. This white paper is available online in the Dell Storage Document Center at <http://www.dellstorage.com/resources/document-center.aspx>.

## Managing Cables in a Standard Installation

Cable management for the FS7500 controller consists of the following steps:

- Route the power cables through the strain relief straps
- Bundle the network and power cables together using the hook-and-loop fasteners supplied in the shipping box
- Secure the network and power cable bundles to the rails

Figure 2-8 shows the back panel of the controller with all of the cable connections. See *BPS and Power Connections* on page 2-5 for detailed information about the cable connections.

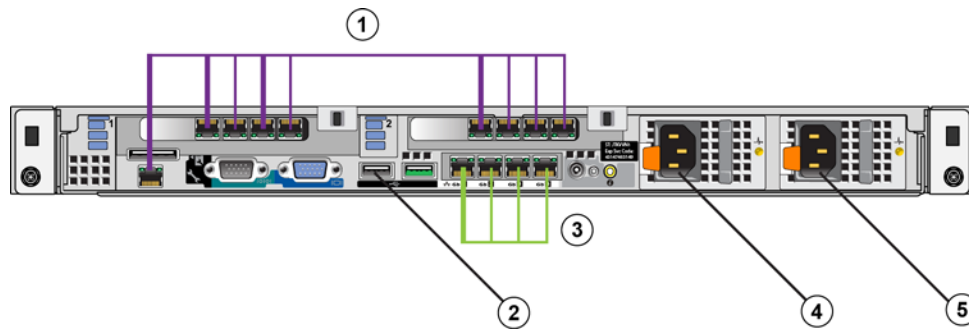
**Figure 2-8: Controller Cable Connections****Table 2-4: Controller Cable Connections**

Number	Description
1	SAN and internal network connections, including the IPMI cable
2	USB connection to BPS
3	Client network connections
4	Power connection to BPS power module
5	Power connection to power source

### Routing the Power Cables Through the Strain Relief Straps

The strain relief straps are located on the D-shaped handles on the back of the power supplies. To route the power cables through the strain relief straps, perform this procedure for each of the power cables on each of the two controllers:

1. Create a small loop near the end of the power cable where it connects to the controller.
2. Secure the cord to the power supply handle using the strain relief strap. The loop that you created in the previous step helps provide the strain relief.

Figure 2-9 shows how to loop the power cables through the strain relief straps.

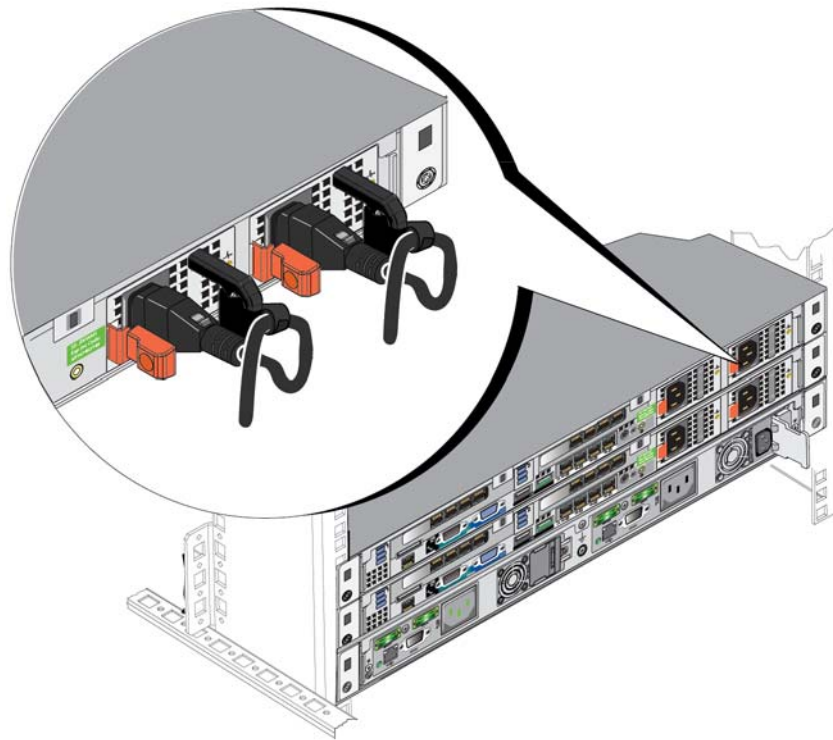

**Figure 2-9: Looping the Power Cables Through the Strain Relief Straps**

### **Bundling the Network and Power Cables**

Using the hook-and-loop fasteners provided in the shipping box, bundle the cables together as follows:

1. Use a hook-and-loop fastener to bundle the network cords together and route the bundle toward the left side of the controller back panel.
2. Use a hook-and-loop fastener to bundle together the two power cables and route them toward the right side of the controller back panel.

### **Securing the Network and Power Cable Bundles to the Rails**

The FS7500 controller rails have brackets attached to the rear of each rail. These brackets extend beyond the back of the system when the rails are installed. Figure 2-10 shows the location of the hook-and-loop fasteners on the brackets.

**Figure 2-10: Cable Management Brackets**

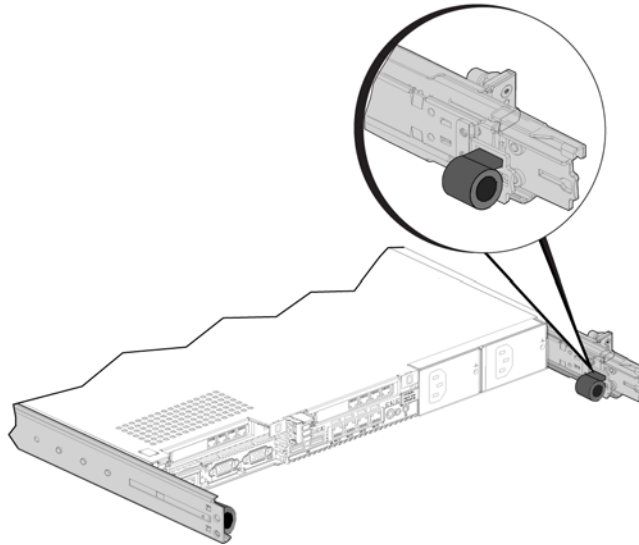

Secure the bundled cords to the brackets as follows:

1. Use the hook-and-loop fastener to secure the bundled network cables to the bracket on the rail on your left as you face the back of the controller.
2. Use a hook-and-loop fastener to secure the bundled power cables to the bracket on the rail on your right as you face the back of the controller.

Figure 2-11 shows the network and power cable bundles. The rails are hidden in this illustration for clarity.

**Figure 2-11: Bundled Signal and Power Cables**

Figure 2-12 shows the back panel of the FS7500 controller with the bundled cords secured to the rails.

**Figure 2-12: Securing the Signal and Power Cable Bundles**

### Steps for Managing Cables Using a Service Loop

A service loop is an extra length of cable between the rear of the rack and the controller. Using a service loop allows you to extend the controller forward on its rails for servicing without needing to disconnect all of the network and power cables from the back panel of the controller.

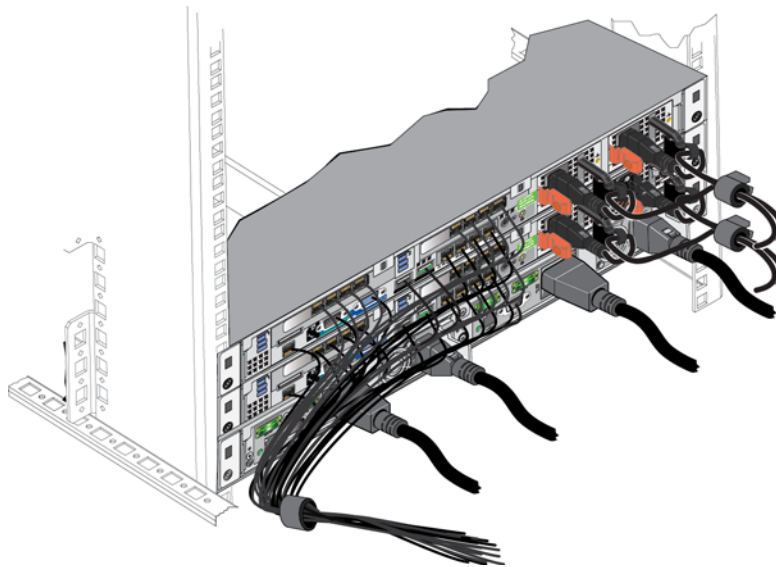
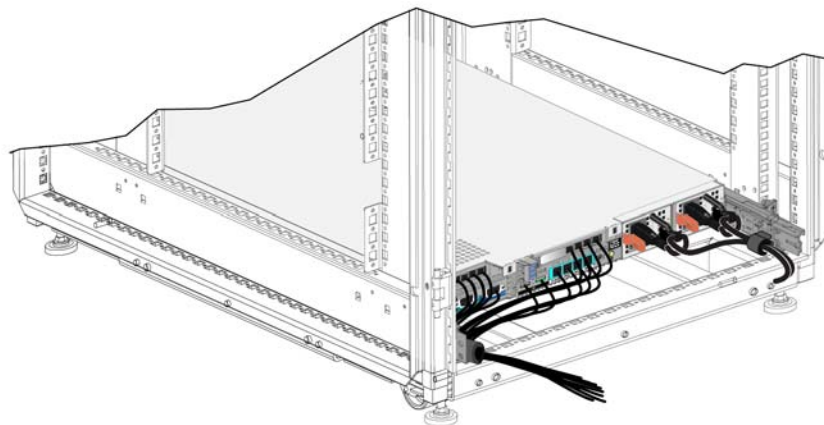
**Note:** Servicing a controller installed with a service loop requires at least two individuals one at the front of the rack and one at the back.

The procedure to install a service loop consists of the following steps:

- Make sure that the network and power cables are properly connected to the controller back panel.
- Extend the controller forward from the rack into the service position
- Route the power cables through the strain relief straps
- Bundle the network and power cables together using the hook-and-loop fasteners supplied in the shipping box
- Secure the network and power cable bundles to the rails
- Slide the controller back into the rack

### Routing the Power Cables Through the Strain Relief Straps

See *Routing the Power Cables Through the Strain Relief Straps* on page 2-12 for the procedure.

**Note:** Using strain relief with the power cables in this installation prevents the controller from being powered down accidentally during servicing.

### Extending the Controller into Service Position

From the front of the rack, extend the FS7500 controller toward you on its rails until the rails click into place. This indicates that the controller is in its service position.

Figure 2-13 shows the controller extended forward into the service position, as viewed from the back of the rack. Note the extra lengths of the power and network cables.

**Figure 2-13: Controller in Service Position**

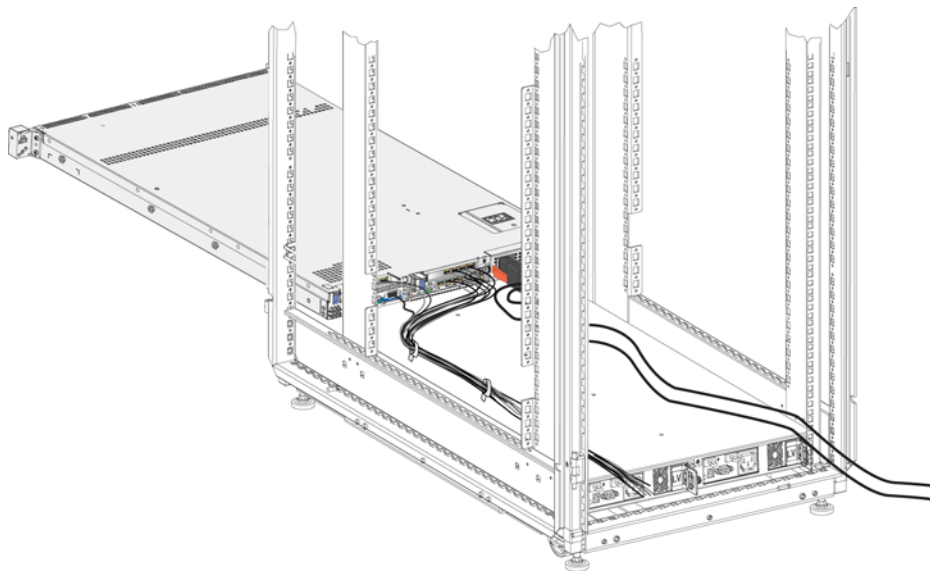

## Bundling Network and Power Cables

If desired, bundle the network and power cables as described in *Bundling the Network and Power Cables* on page 2-13. If you bundle the cables, use the hook-and-loop fasteners to secure them together.

**Note:** Securing the network cable and power cable bundles to the rails is optional. If you do secure the cable bundles to the rails, they will need to be unsecured before the controller can be extended for service.

## Turning On Power to a Controller

From the front of the controller, press the power button on the left side of the controller. See Figure 1-2 for the location of the power button.

An LED indicator on the controller power button indicates if power is supplied to the controller and if the controller is operational.

In addition, the controller power supplies have an LED that shows whether power is present or whether a power fault has occurred, as shown in Figure 1-5 and described in Table 2-5.

**Table 2-5: FS7500 Controller Troubleshooting – Power Supply LED**

LED Color and Patterns	Description
Not lit	No power.
Green	When the controller is in standby mode (power connected but the controller is not turned on), a green LED indicates that a valid AC source is connected to the power supply, and that the power supply is operational. When the controller is turned on, a green LED also indicates that the power supply is providing DC power to the controller.
Amber	Indicates a problem with the power supply.
Alternating green and amber	Flash upgrade is in progress.

## Powering Down the Controller

To initiate a clean shutdown of the controller, quickly press and release the power button. The controller writes any remaining data in the cache to storage, and then executes a graceful shutdown. To reboot the controller, quickly press and release the power button again. Make sure that the controller power is completely off before you reboot the controller.

**Caution:** Do not press and hold the power button to shut down the controller. Powering down the controller using this method can cause data loss. Never power down both controllers at once.



## 3 Maintaining System Components

---

This chapter describes some common maintenance tasks for the FS7500 controller, as well as removal and replacement procedures for customer replaceable components.

**Note:** Many repairs may only be done by a certified service technician. You should only perform troubleshooting and simple repairs as authorized in your product documentation, or as directed by your service and support team. Damage due to servicing that is not authorized is not covered by your warranty. Read and follow the safety instructions that came with the product.

### Removing and Replacing a Controller

To replace one controller in a controller pair, perform the following procedure. Each step in the procedure is described in detail in later sections.

- Detach the controller from the NAS node pair in which it was installed.

**Note:** You should only detach a controller from the NAS node while under the instruction of a service representative. Refer to the *PS Series Group Administration* manual and the *EqualLogic FS7500 Release Notes*.

- Remove the front bezel. See *Removing the Controller Bezel* on page 2-3
- Power down the controller. See *Powering Down the Controller* on page 2-17
- Remove the power and network cords.
- Slide the controller forward in the rack to the service position. See *Managing the Controller Cables* on page 2-11
- Remove the controller from the rack.
- Install a new controller in the rack. See *Installing System Components* on page 2-1
- Connect the power and network cords.
- Turn on power to the new controller.
- Obtain the service tag for the new controller. See *Displaying the Service Tag* on page 4-1
- Attach the front bezel. See *Attaching the Controller Bezel* on page 2-4.
- Attach the new controller to the NAS node pair from which you detached the controller that you replaced.

### Uninstalling the Controller from the Rack

1. Slide the controller forward in the rack until the controller clicks into place in the service position.
2. Remove the controller from the rails.

## Installing the Replacement Controller

Install the replacement controller as described in the EqualLogic *FS7500 Installation and Setup Guide*.

## Attaching the Cables

Establish the BPS, power, and network connections for the controller as described in Chapter 2, *Installing System Components*.

## Turning on the Power

Turn on power to the controller as described in *Turning On Power to a Controller* on page 2-17.

## Obtaining the Service Tag

The service tag (also called the System ID) is the 7-character unique identifier for each controller in your installation. See *Displaying the Service Tag* on page 4-1.

The service tag appears in the LCD screen on the front panel of a powered-on controller (see *LCD Screen and Control Keys* on page 1-2). Use the buttons next to the display to navigate the display commands.

## Attach the Controller to the NAS Node Pair

Attach the controller to the NAS node pair as described in the PS Series *Group Administration* manual.

## Removing and Installing a Disk Drive

The FS7500 controller supports up to six 2.5 inch SAS disk drives. This section discusses how to handle and store disk drives, as well as how to install and remove the drives and drive blanks.

## Disk Drive Handling Requirements

Observe the following considerations when installing hard drives:

- Install all disk drives from the front of the system. The drives connect to the system board through the SAS backplane board. Disk drives are supplied in special hot-swappable drive carriers that fit into the disk drive bays.
- Protect disk drives from electrostatic discharge. When handling a disk drive, always wear an electrostatic wrist strap or similar protective device. See *Using an Electrostatic Wrist Strap* on page 2-2.
- Handle disk drives carefully. Hold a disk drive only by the plastic part of the carrier. Do not handle a disk drive solely by the release lever.
- Insert a disk drive properly. Do not force a disk drive into a slot.



- Warm disk drives to room temperature before installation. For example, let a disk drive sit overnight before installing it in the controller.
- Do not remove a disk drive from its carrier. This action will void your warranty and support contract.
- Operate the controller with drive blanks in all unused drive bays. This maintains proper system cooling. Minimize the time when the chassis is open. Do not remove a failed disk until you are ready to replace it.
- Install the same type of disk drives. Install only disk drives of the same capacity, speed, and spin rate.
- Do not remove a functioning disk drive from the controller. If you remove a spare disk drive, replace it as soon as possible.
- Store disk drives properly. Store replacement disk drives in the packaging in which they were shipped.

**Caution:** Do not turn off or reboot the controller while the drive is being formatted. Doing so can cause a drive failure.

## Removing a Drive Blank

To remove a drive blank, follow these steps:

1. Remove the front bezel from the controller. See *Uninstalling the Controller from the Rack* on page 3-1.
2. Press the button on the left side of the drive blank. Grasp the drive carrier release handle and slide the blank out of the drive bay.

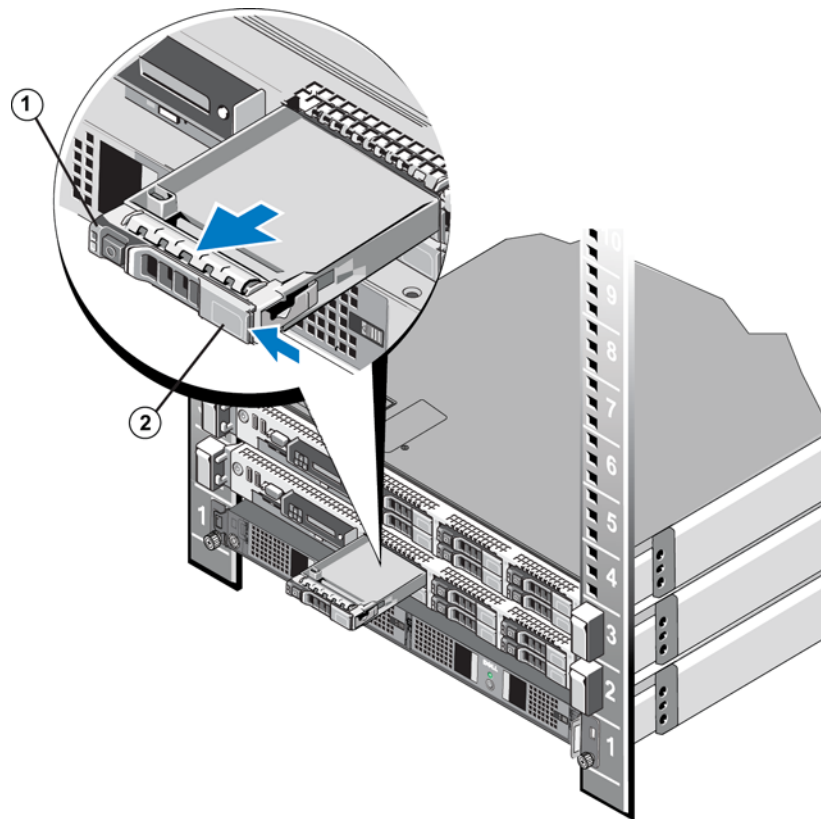
**Figure 3-1: Removing a Drive Blank**

## Installing a Drive Blank

1. Align the drive blank with the drive bay.
2. Insert the blank into the drive bay and push gently until the release button clicks into place.
3. Reinstall the controller bezel. See *Attach the Controller to the NAS Node Pair* on page 3-2

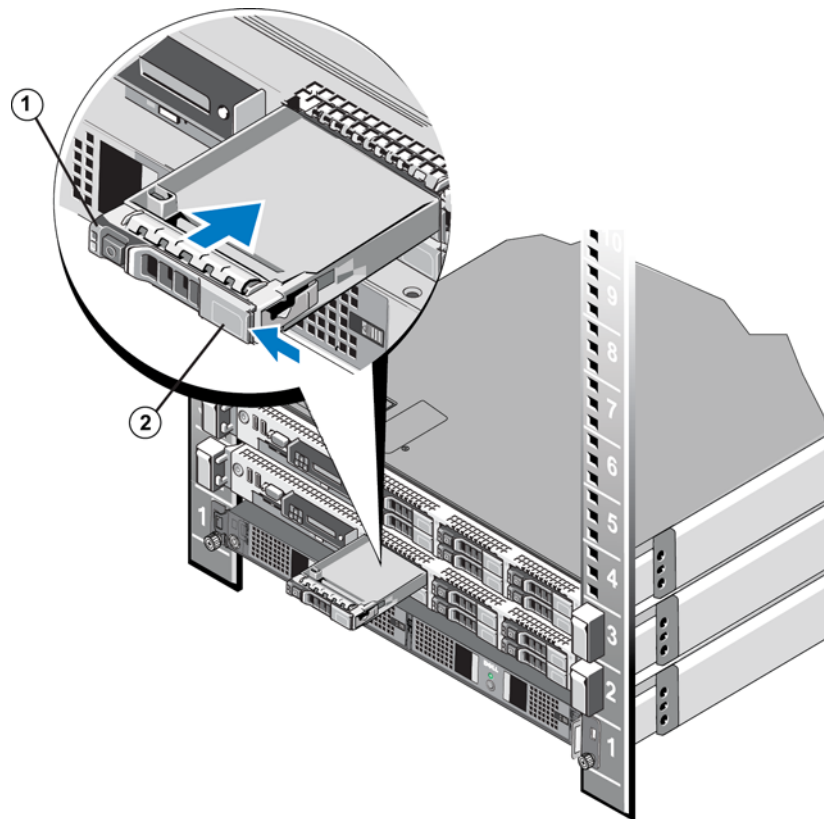
**Figure 3-2: Installing a Drive Blank**

## Removing a Hot-Swap Disk Drive

1. Remove the front bezel from the controller. See *Uninstalling the Controller from the Rack* on page 3-1.
2. Identify the drive you want to remove. You can obtain this information from the event log and from the disk LEDs.
3. Take the drive offline. If the drive has been online, the green activity/fault LED (bottom LED) will flash as the drive is powered down. When the drive indicator LEDs are off, the drive is ready for removal.
4. Press the release button. Open the drive carrier release handle to release the drive.
5. Slide the drive out of the drive bay.

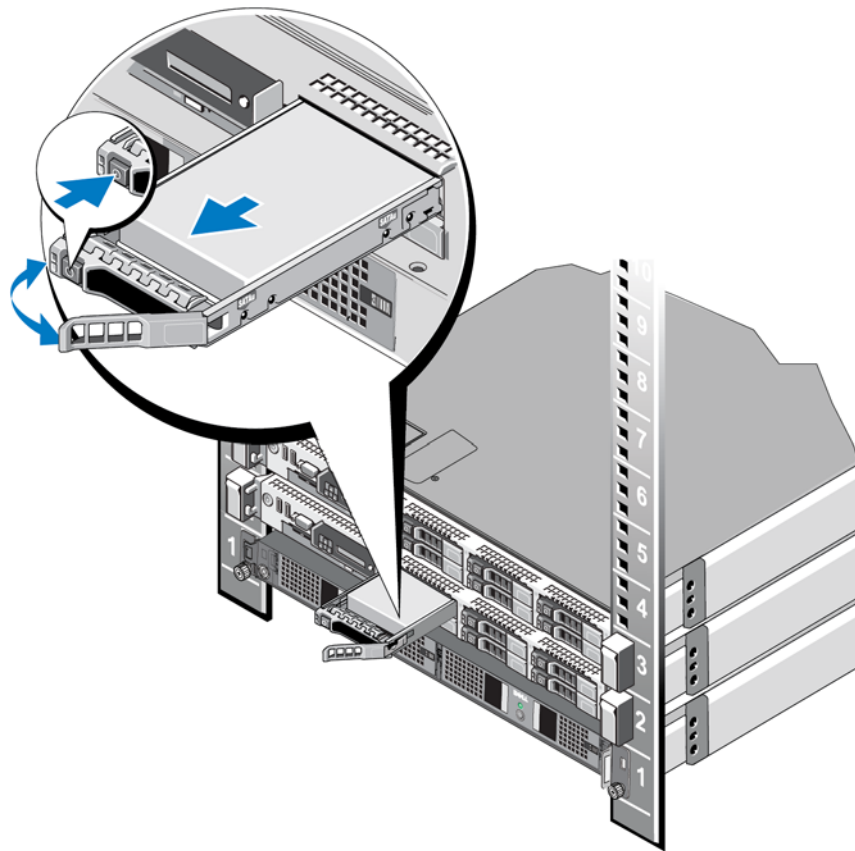
**Figure 3-3: Removing a Disk Drive**

6. Insert a drive blank in the empty drive bay, or install a replacement disk drive.

**Note:** All empty drive bays must have drive blanks installed. This helps maintain proper system cooling.

## Installing a Hot-Swap Disk Drive

**Caution:** Before you install a hard drive, make sure that the adjacent drives are fully installed and that their release buttons are locked. Inserting a hard drive carrier next to a partially installed disk drive can damage the carrier of the partially installed drive and make that carrier unusable.

1. Remove the front bezel from the controller. See *Removing the Controller Bezel* on page 2-3.
2. If a drive blank is present in the bay, remove it. See *Removing a Drive Blank* on page 3-3.
3. Press the release button on the drive carrier to open the release handle.
4. Carefully align the drive carrier with the drive bay and push it gently into place.

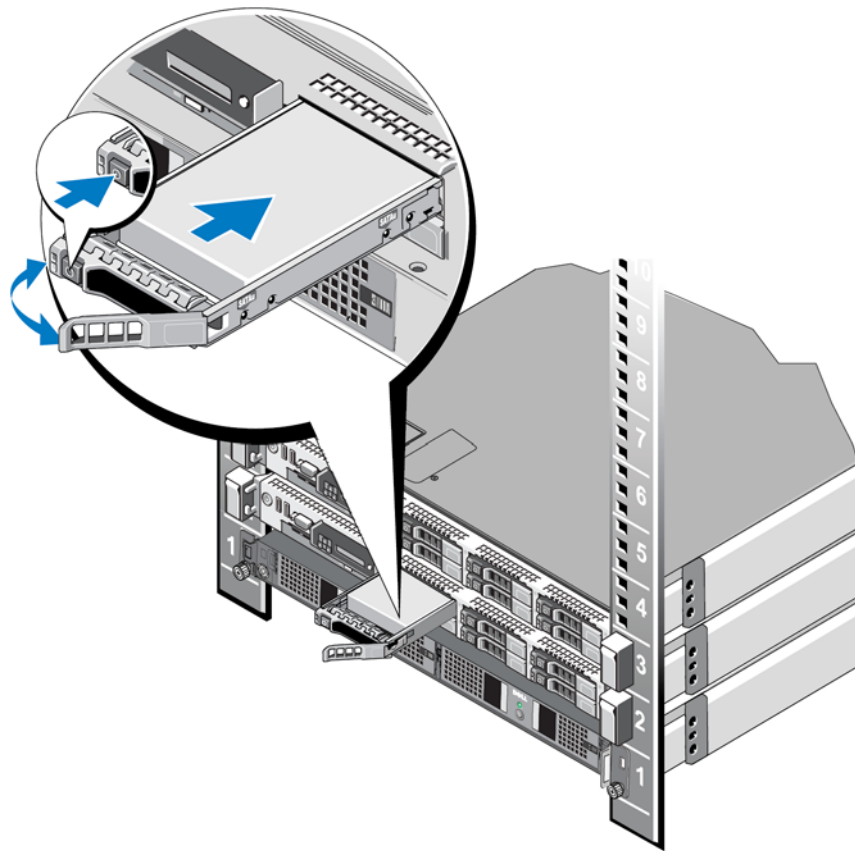
**Figure 3-4: Installing a Disk Drive**

5. Close the handle to secure the drive.

## Removing and Installing a Power Supply

The FS7500 controller supports the 502 W Energy Smart power supply modules.

**Note:** The recommended installation for the FS7500 includes two power supplies. The second power supply ensures continued operation and high availability in the event of a power or power supply failure.

**Note:** Replace the power supply that has the flashing indicator with a power supply that matches the capacity of the other installed power supply. Swapping the other power supply to create a matched pair can result in an error condition and unexpected controller shutdown.

### Removing a Power Supply

1. Disconnect the power cord from the power source and the power supply that you intend to remove. Remove the cords from the strain relief straps.
2. Press the release latch and slide the power supply out of the controller chassis.

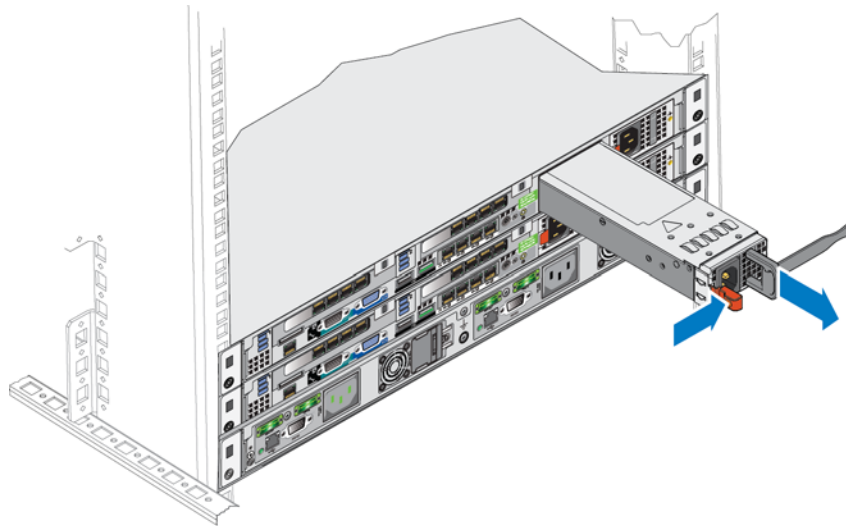
**Figure 3-5: Removing the Controller Power Supply**

## Installing a Power Supply

**Caution:** Always replace a power supply with a power supply that has the same output capacity. The maximum output capacity is listed on the power supply label. The FS7500 controller supports the 502 W Energy Smart power supply module.

1. If the controller has two power supplies installed, verify that they are the same type and have the same maximum output power as the new power supply.
2. Slide the new power supply into the controller chassis. The release latch clicks back into place when the power supply is properly installed.

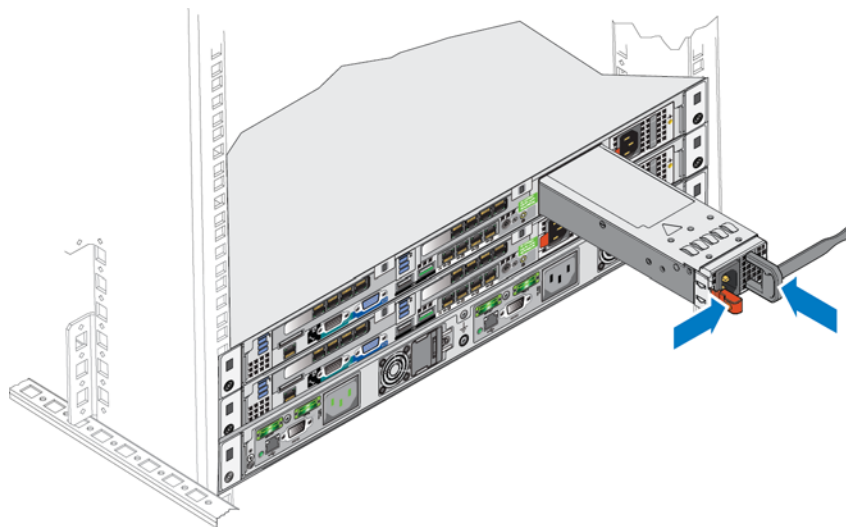
**Figure 3-6: Installing a Controller Power Supply**

3. Connect the power cord to the power supply and to the power source.
4. Secure the cords using the strain relief straps.
5. Turn on power to the power supply.
6. Allow several seconds for the controller to recognize the new power supply and determine its operational status. The power supply status indicator LED turns green when the power supply is functioning properly.

## Power Supply LED Status

An LED indicator on the controller power button indicates if power is supplied to the controller and if the controller is operational.

In addition, the controller power supplies have an LED that shows whether power is present or whether a power fault has occurred.

**Table 3-1: FS7500 Controller Troubleshooting – Power Supply LED**

LED Color and Patterns	Description
Not lit	No power.
Green	When the controller is in standby mode (power connected but the controller is not turned on), a green LED indicates that a valid AC source is connected to the power supply, and that the power supply is operational. When the controller is turned on, a green LED also indicates that the power supply is providing DC power to the controller.
Amber	Indicates a problem with the power supply.
Alternating green and amber	Flash upgrade is in progress. Check the status LEDs on the BPS power supplies.





## 4 Troubleshooting

---

The sections in this chapter describe how to obtain information about the FS7500 controller, as well as how to troubleshoot common hardware conditions.

For information about setting up the NAS service, see the EqualLogic FS7500 *Installation and Setup Guide*. For information about how to troubleshoot software issues, see the PS Series *Group Administration Manual*. See Chapter 5, *What to Do Next*, for more information about the FS7500 controller.

### Obtaining the Controller Service Tag

The service tag is a unique string of seven alphanumeric characters that identifies a controller to the network. You need to know the service tag of a controller before you can add it to the network.

The service tag appears in the LCD screen on the front panel of a powered-on controller (see Figure 1-3 on page 1-3).

### Displaying the Service Tag

Use the buttons next to the display to navigate the display commands. To display the service tag, do the following:

1. Press the check-mark button.
2. Press the right arrow. The screen shows View.
3. Press the check-mark button.
4. Press the right arrow. The screen shows Number.
5. Press the check-mark button.
6. Press the right arrow. The screen displays the service tag.



## 5 What to Do Next

---

The EqualLogic FS7500 *Installation and Setup Guide* contains detailed information about the FS7500 controller, including unpacking and racking information and procedures for setting up a NAS service.

The PS Series *Group Administration* manual provides detailed NAS service information. The Group Manager online help describes how to use the Group Manager graphical user interface (GUI) to manage a NAS service.

The PS Series *CLI Reference* manual and the Group Manager command line interface (CLI) help describe how to use the CLI to manage a NAS service.

The FS7500 Backup Power Supply *Hardware Reference Guide* contains maintenance and troubleshooting information for the FS7500 BPS.

For the latest information about NAS services, see the Dell EqualLogic customer support website.



## A FS7500 Controller Technical Specifications

---

### FS7500 Controller Technical Specifications

Table A-1: FS7500 Controller Technical Specifications

Component	Requirement
Weight of controller	Empty: 29.2 pounds or 13.25 kilograms
Operating temperature	50 to 95 degrees F / 10 to 35 degrees C
Storage temperature	-40 to 149 degrees F / -40 to 65 degrees C
Operating altitude	-50 to 10,000 feet (-16 to 3048 meters)
Operational relative humidity	20 to 80 percent non-condensing
Thermal output (fully-loaded controller)	2446.5 BTU/hr maximum (High Output) 1712.9 BTU/hr maximum (Energy Smart)
Operational shock	Half sine shock in all operational orientations of 31G plus or minus 5% with a pulse duration of 2.6 ms plus or minus 10%
Operational vibration	0.26 Gms from 5-350 Hz for 5 minutes in operational orientations
Input voltage	90 to 264 VAC (auto-sensing)
Input frequency	47 - 63 Hz
System input power	90-264 VAC, autoranging, 47-63 Hz
Each power supply	502 W Input current: up to 55 A per power supply for 10 ms or less
Dimensions	1.68 in. height x 18.99 in. width x 30.39 in. depth (4.26 cm height x 48.24 cm width x 77.2 cm depth)



# Index

---

## B

Back panel 1-4

Bezel

    reinstalling 2-4

    removing 2-3

BPS

    connections 2-5

## C

Cable management 2-11

    methods 2-11

Cable management brackets 2-13

Cables

    bundling for a service loop 2-17

    managing 2-11

    numbers needed 2-7

Cabling

    client network 2-11

    SAN and internal network 2-10

cabling

    routing the power cords 2-12

Clean shutdown 2-17

Client network 2-6

    cabling 2-11

    Ethernet ports 2-7

Components 1-1

    customer replaceable 1-1

Configuration

    minimum 2-8

    recommended 2-8

Control keys 1-2

Controller

    cable connections 2-11

    cable management 2-11

    power button LED 3-9

    removing and replacing 3-1

    routing the power cord 2-12

    securing power cables 2-14

    service position 2-16

    strain relief straps 2-12

    troubleshooting 3-9

Controller cables

    managing 2-11

    routing 2-11

Custom racking

    cable management 2-11

## D

D 2-12

Drive status indicators 1-3

## E

Electrostatic wrist strap 2-2

Environmental considerations 2-2

Ethernet ports 2-6

    diagram 2-7

## F

Flow Control

    setting 2-8

Front panel 1-2

Front panel cover

    see Bezel 2-4

## H

Hard disk

    See Hard drive 1-3

Hard drive

    failure 1-4

    LED activity states 1-4

    LED location 1-3

    LED state during installation 1-4

Hard drives

    status indicators 1-3

hardware

    not supplied 2-2

High availability

    and power sources 2-6

    configuration 2-8

    network configuration 2-7

    second power supply 3-7

    switches 2-7

Hot swapping disk drives 3-5

## I

installation safety precautions 2-1

Installing hardware 2-1

Internal network 2-6

    Ethernet ports 2-7

IPMI 2-7

IPMI port 1-5

## J

Jumbo Frames

    setting 2-8

## **L**

- LCD screen 1-2, 4-1
  - colors 1-3
  - operational states 1-3
  - turning on after inactivity 1-3

## **LED**

- controller 3-9
- power supply 2-17

## **M**

- Minimum configuration
  - cabling 2-10
  - diagram 2-10

## **N**

### **Network**

- client 2-6
- internal connections 2-6
- SAN 2-6
- security considerations 2-6

### **Network cables**

- recommended number 2-8

### **Network configuration 2-6**

### **Network connections 2-6**

- Network interface card
  - see NIC 2-6

- Network interface ports 2-6
  - diagram 2-7

### **Network status LEDs 1-6**

### **Network switch 2-2**

### **Network switch configuration 2-7**

## **NIC**

- connections 2-7

## **NICs 2-6**

## **P**

### **Power**

- connections 2-5
- high availability 2-6

### **Power button**

- shutdown 2-17

### **Power cables 2-6**

### **Power connections 2-5**

### **Power on 2-17**

### **Power supply**

- LED 2-17
- removing and replacing 3-7

## **R**

### **Rails 2-11**

- cable management brackets 2-13
- static 2-11

### **Rebooting 2-17**

### **Recommended configuration**

- cabling 2-10
- diagram 2-9

### **References**

- installation and setup 5-1
- NAS service information 5-1

### **references**

- BPS 5-1
- CLI 5-1

### **Replacing 3-1**

### **required hardware (not supplied) 2-2**

### **Restarting 2-17**

## **S**

### **safety precautions, installation 2-1**

### **Safety recommendations 2-1**

### **SAN network 2-6**

- Ethernet ports 2-7

### **Service loop 2-11, 2-15**

- advantages 2-11
- installing 2-15
- persons needed 2-15

### **Service position 2-16**

### **Service tag 1-2, 4-1**

- displaying 4-1
- location 4-1

### **Shutdown**

- clean 2-17

### **Standby mode 2-17, 3-9**

### **Static electricity**

- protecting the hardware 2-2

### **Storage 2-2**

### **Strain relief 2-11**

- used in a service loop 2-16

### **Strain relief strap**

- used for the power cable 2-12

### **Strain relief straps 2-16**

- on the controller 2-12

### **switches**

- 10GE 2-2

### **System ID**

- see also Service tag 4-1



**T**

Troubleshooting

    Controller LEDs 3-9

Turning off power 2-17

Turning on power 2-17

**U**

Ungraceful shutdown 2-17

Unicast storm control  
    setting 2-8

**USB**

    connections 2-5

USB cables 2-5

**V**

VLANs 2-8

