

## FS7610 Installation

### Before You Begin

This poster is a condensed reference. Read the *Dell™ EqualLogic® FS7610 Installation and Setup Manual* (provided in the box) for complete installation information.

Your Dell™ FS7610 system comes with a Dell service contract. A representative from Global Infrastructure Delivery Services will contact you to install your system. If you have any questions regarding these requirements, discuss them with your Dell service engineer or contact Dell Technical Support.

If you do not have a Customer Service Support account, go to [eqsupport.dell.com](http://eqsupport.dell.com) and create one. Download and read the *FS Series Release Notes* from the support site. The release notes contain the latest product information.

#### Environmental Requirements

Ensure the installation location meets the power, cooling, and ventilation requirements listed in the *Dell EqualLogic FS7610 Installation and Setup Manual*, located in the shipping box.

#### Required Hardware (Not Supplied)

- 19-inch (48.3 cm) four-post rack
- **10GBASE-T:** Use Category 5E or Category 6 cables with RJ45 connectors. Use Category 5 cables only if they meet the TIA/EIA TSB95 standard.
- **SFP+:** Use fiber-optic cables with SFP+ plug-in modules, or copper cables with integrated SFP+ modules. Refer to the release notes for customer kit part numbers of supported SFP+ transceivers and cables.
- Two network switches (four for high-availability configurations).

#### Additional Information About SANs

For EqualLogic best practices whitepapers, reference architectures, and sizing guidelines for enterprise applications and SANs, refer to the Dell Storage Community at [dell.to/sM4hJT](http://dell.to/sM4hJT).

## 1 Unpack the Shipping Box

**Caution:** Protect sensitive hardware. Use an electrostatic wrist strap or similar form of protection when handling hardware.

#### Shipping Box Contents:

- NAS Appliance
- Bezel
- 2 power cables
- Debug serial cable
- Rail kit
- Documentation

## 2 Locating Your System Service Tag

- Your system is identified by a unique Express Service Code and Service Tag number, located on the rack mounting support bracket. (This information is also located on the upper left-hand corner of the back panel).
- This information is used by Dell to route support calls to the appropriate personnel.

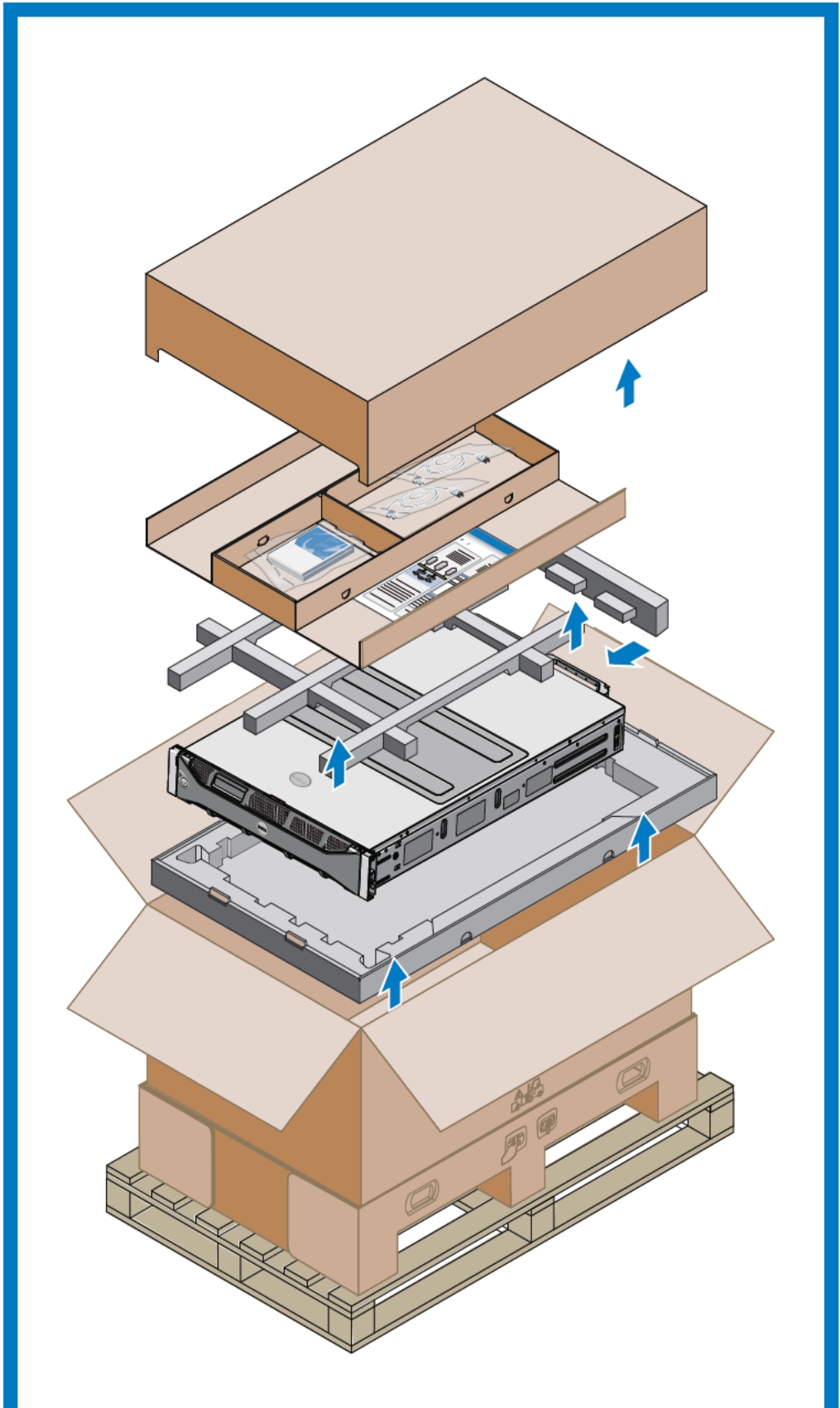
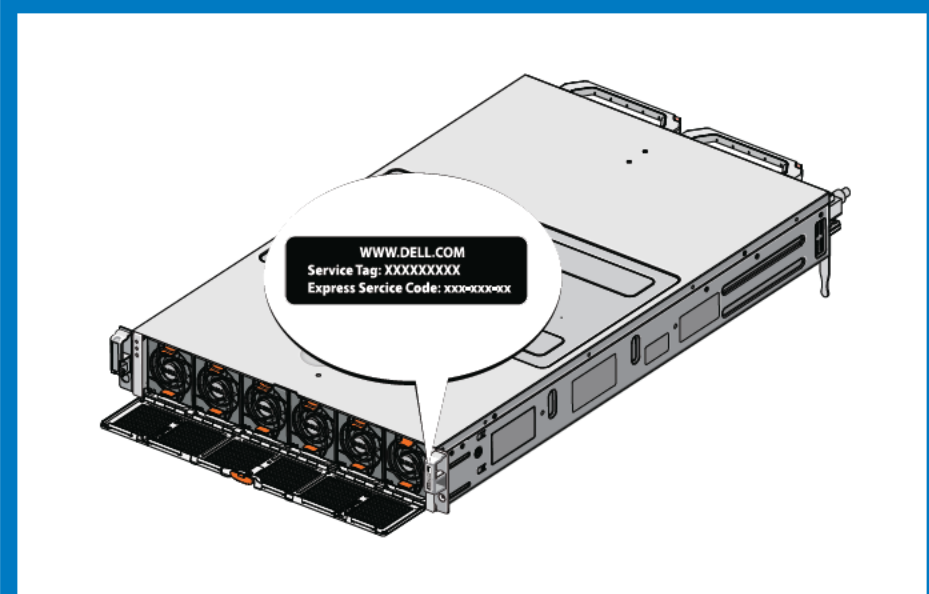

## 3 Install the Appliance Into the Rack

1. Obtain the rail kit from the appliance shipping box.
2. Install the rails in the rack. See the Rack Installation setup poster (in the rail box) for detailed instructions.
3. Slide the appliance into the rack.
4. Hand-tighten the thumbscrews to the front of the rack.

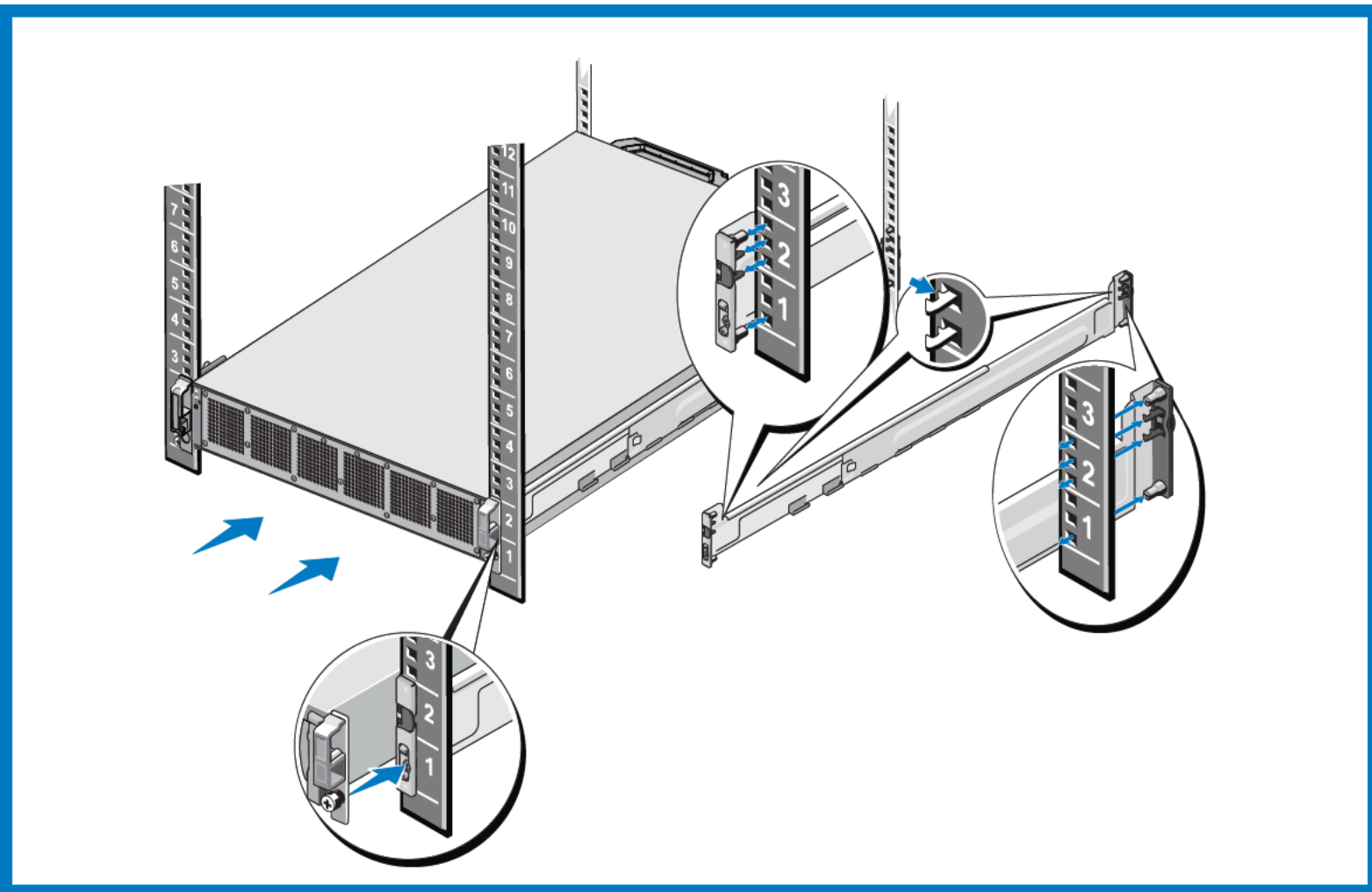

## 4 Connect the Appliance to Power

Connect the appliance to two different power sources, if possible. The system turns on automatically. Check the power LED on the front of the appliance. The Power-On Indicator/Power Button on the rear of the system blinks fast green (five times per second) indicating that the controller is in a standby state waiting to be clustered.

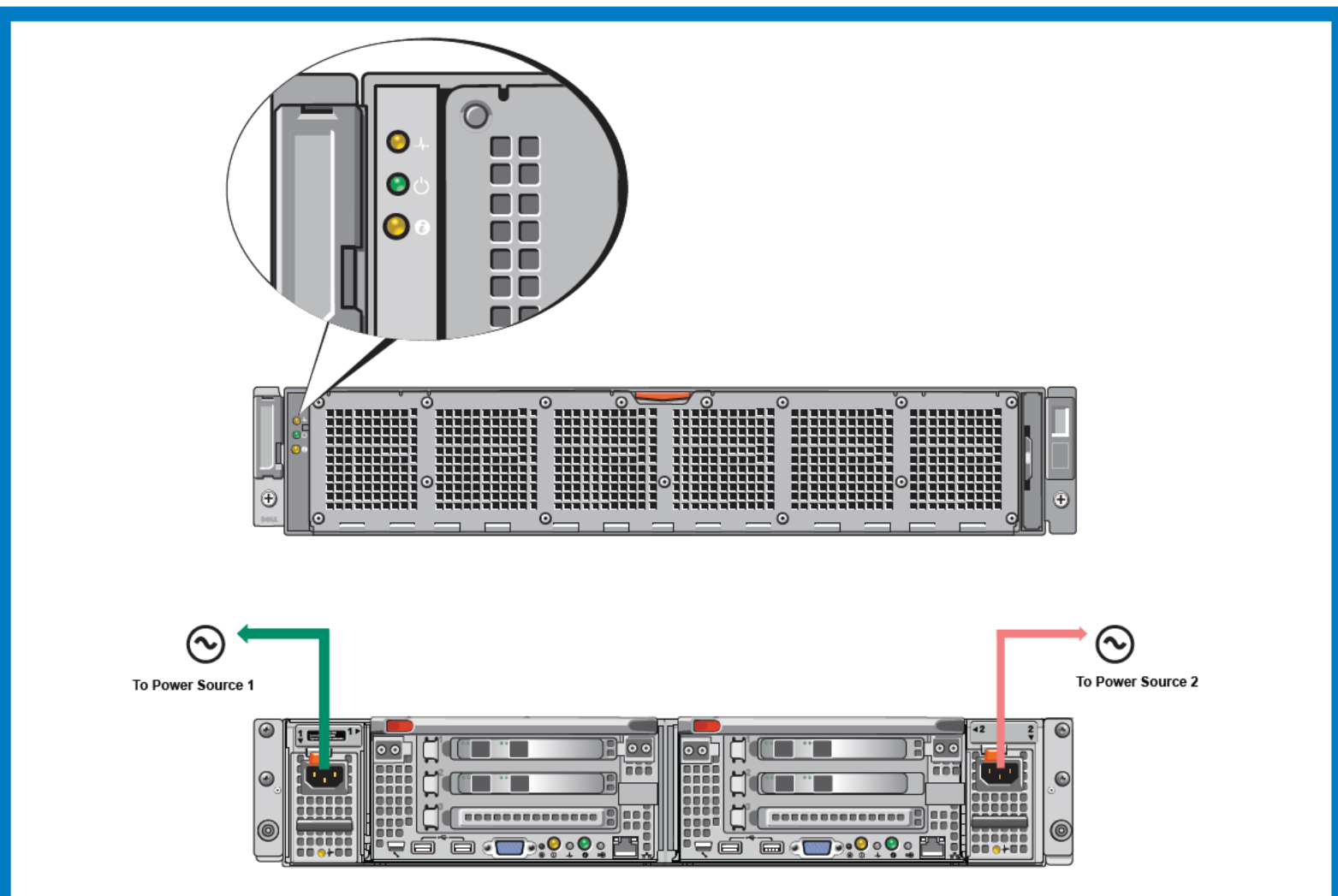

## 5 Connect the Appliance to the Networks

### Cabling Requirements

- To rack and cable the FS7610 system, follow the cabling diagram and instructions in *Dell EqualLogic FS7610 Installation and Setup Manual*.
- Optical or twin-axial cables: You need 18 network cables for the FS7610 NAS appliance.
  - 10GBASE-T: Use CAT6 cable (or better) for up to 55 meters, or CAT6A or CAT7 for up to 100 meters.
  - SFP+: Use fiber-optic cable acceptable for 10GBASE-SR (50 micron multimode fiber), or copper SFP+ cable.
  - Do not use a router between the NAS appliance and the PS Series arrays.

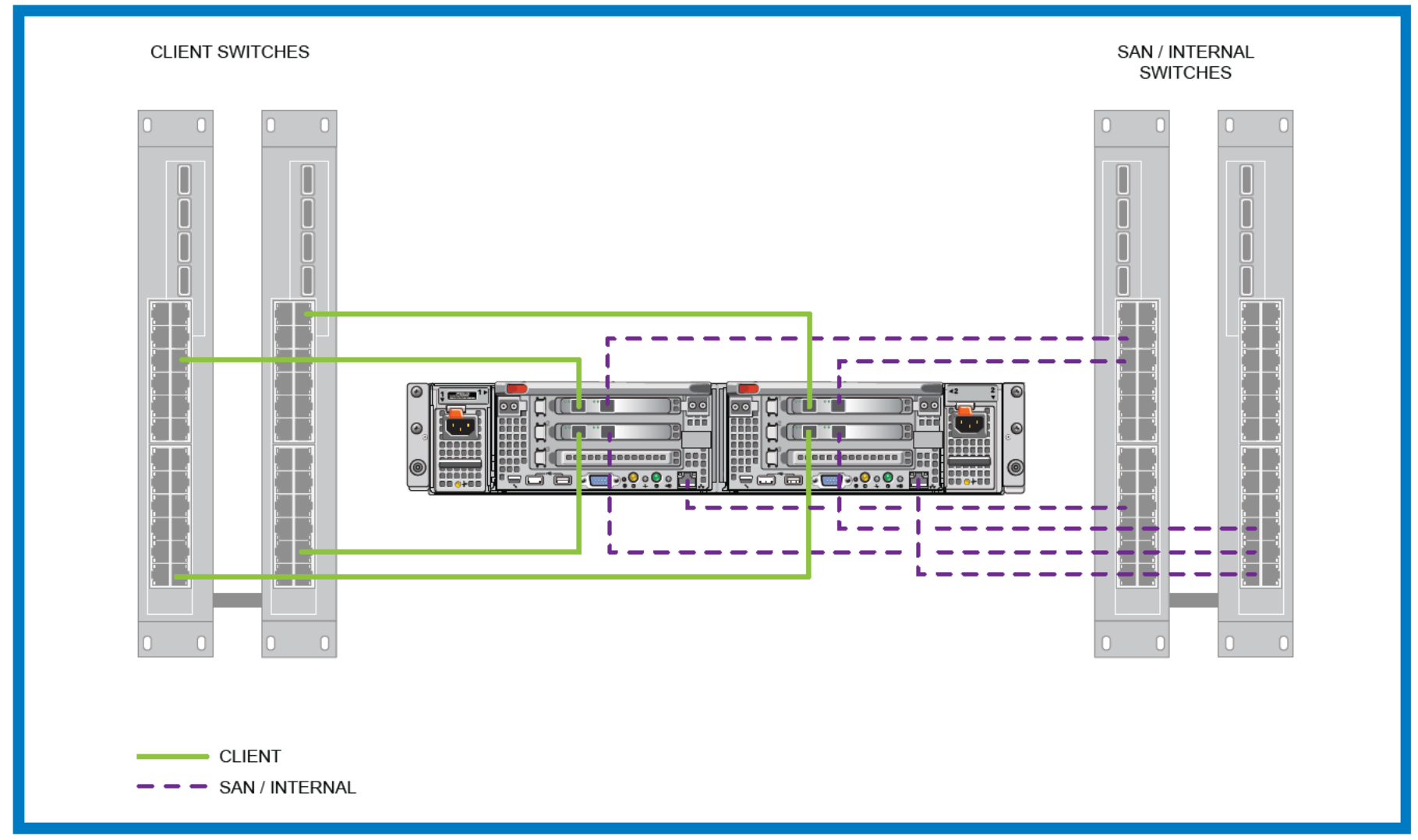

### Network Connection Requirements and Recommendations

#### The Dell FS7610 appliances have the following types of networks:

- Client Network—Enables the system to connect to your user clients for file data access.
  - SAN/Internal Network—Enables internal communication between the controllers required for failover and heartbeat, and communication between the controllers and the EqualLogic PS Series SAN for storing user data. The SAN/Internal network is connected to the same set of Ethernet switches.
- Note:** Dell strongly recommends using a highly available network topology for both your SAN/Internal and client networks. The SAN/Internal and client networks should not share the same physical network infrastructure. Ideally, you want a network switch configuration in which a switch failure does not disrupt the availability of the NAS cluster. No single switch should have all the client, SAN, or internal network connections.

#### Network Requirements

Use separate subnets for the client network, the SAN, and the internal network.

#### Client Network Requirements

- The client network should be redundant and configured for high availability. Flow control is not required, but Dell recommends using flow control on the client switches.
- Caution:** If you change the default load balancing to LACP or if you use standalone switches, the switches must be stacked.
- The client network on the FS7610 is set to 1500 MTU by default. However, you can modify the setting on client network switches to enable jumbo frames if required.

#### SAN/Internal Network Requirements

- FS7610 appliances use IPv6 Link-Local Addressing for node discovery and communication on the SAN/Internal network. IPv6 networking traffic must not be blocked on switches used by the SAN/Internal network. Routing of IPv6 traffic is not required on the SAN/Internal network switches. IPv6 communication is not used on the FS7610 client network.
- Connect the SAN/Internal network ports on each network interface card (NIC) to different switches.
- Set your SAN/Internal switch MTU size to 9000 or greater and enable the following features:
  - Spanning Tree Protocol for the quickest convergence (such as RSTP)
  - PortFast or fastlink (also called end-node or leaf-node)
  - Flow control
- Enable jumbo frames (to support a frame size of 9000 bytes) on the SAN/Internal network switches. Note that Dell PowerConnect switches must be configured to 9216 MTU. Switches from vendors other than Dell might require a different MTU configuration to accept frames of 9000 bytes.
- Disable Unicast storm control on the SAN/Internal switches.
- Disable IGMP and/or MLD snooping on the switch ports to which the SAN/Internal ports of the FS7610 are connected. Refer to your switch manual for instructions on disabling IGMP/MLD snooping on the SAN/Internal switch.

**Note:** If you use VLANs within your switch stack, the internal and SAN networks must be in the same VLAN.

**Note:** Make sure that you do not have any duplicate IP addresses in the SAN, internal, and client networks.

## 6 Attach the Bezel

1. Insert the right side of the bezel into the slot on the right side of the appliance.
2. Push the bezel toward the left side of the appliance.
3. Lift the latch on the left side of the bezel.
4. Engage the bezel with the left side of the appliance.
5. Release the latch.
6. Use the key to lock the bezel.

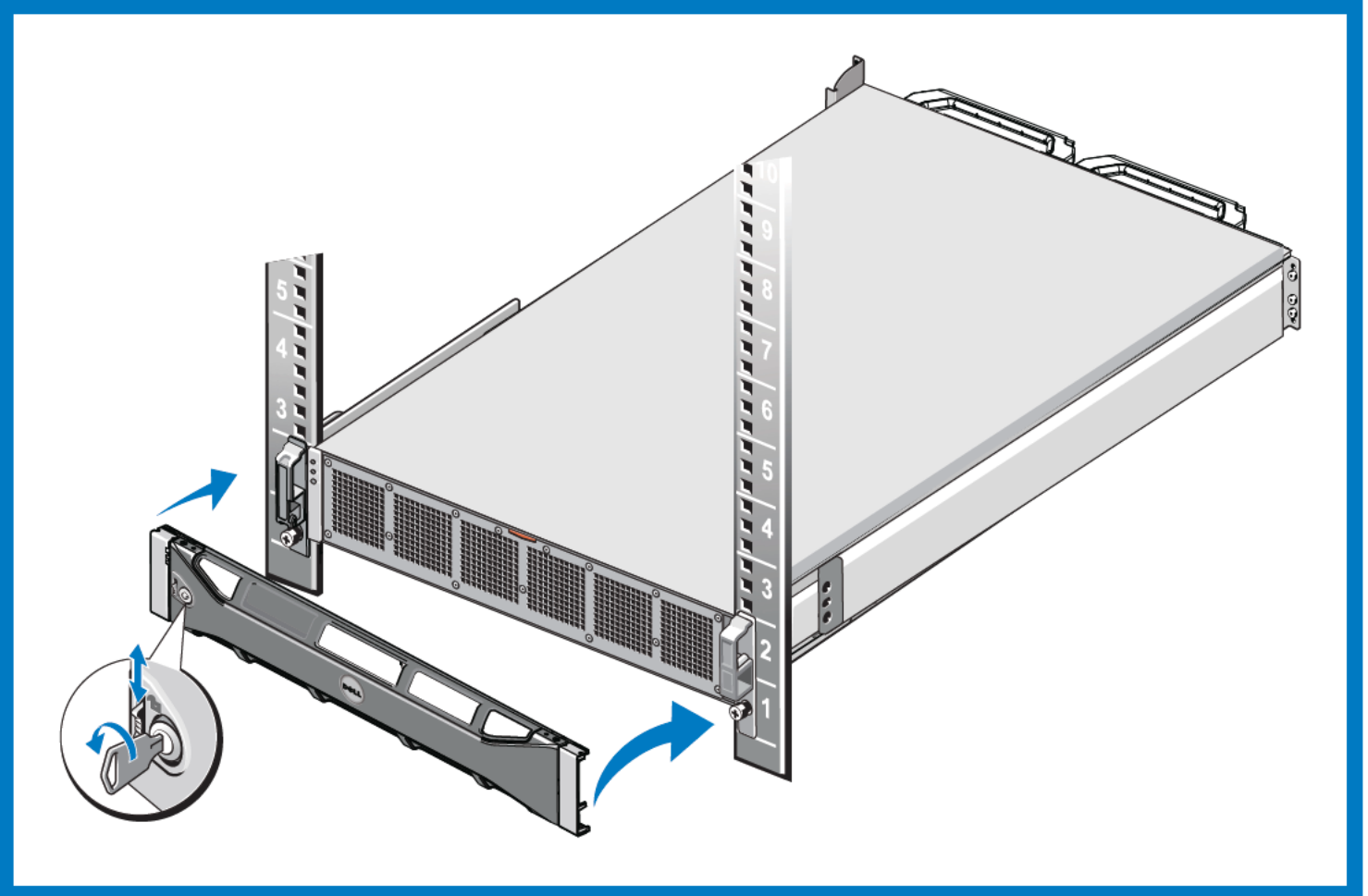

### Hardware Installation Is Complete!

Your appliance should now be up and running. If it is not, make sure that you have successfully completed all of the steps described in this poster.

If you are still experiencing problems, see the *Dell EqualLogic FS7610 Installation and Setup Manual* for additional installation information. The *Dell EqualLogic FS7610 Installation and Setup Manual* also provides technical support and customer service information.

For live technical support, call 1-800-945-3355.

### What to Do Next

Configure the NAS Cluster. See the *Dell EqualLogic FS7610 Installation and Setup Manual* for information.

**Notes, Cautions, and Warnings**

- A **NOTE** symbol indicates important information that helps you make better use of your hardware.
- A **CAUTION** symbol indicates potential damage to hardware or loss of data if instructions are not followed.
- A **WARNING** symbol indicates a potential for property damage, personal injury, or death.

Information in this document is subject to change without notice.

Reproduction in any manner whatsoever without the written permission of Dell EqualLogic is strictly forbidden.

Dell™ and EqualLogic® are trademarks of Dell Inc. © Copyright 2012 - 2013 Dell Inc. All rights reserved.

Printed in U.S.A.  
Printed on recycled paper.



GX40MA02