

Dell EMC DSS 9620 Servers Installation and Service Manual

Regulatory Model: B09B Series
Regulatory Type: B09B002



Notes, cautions, and warnings



NOTE: A NOTE indicates important information that helps you make better use of your system.



CAUTION: A CAUTION indicates a potential for damage to hardware or loss of data if instructions are not followed.



WARNING: A WARNING indicates a potential for property damage, personal injury, or death.

Copyright © 2017 Dell Inc. or its subsidiaries. All rights reserved. Dell, EMC, and other trademarks are trademarks of Dell Inc. or its subsidiaries. Other trademarks may be trademarks of their respective owners.

2017 - 10

Rev. A00

Contents

1	Overview	1
	2.5-inch half-width server	1
	3.5-inch half-width server	2
	System specifications	4
	Front-panel features	5
	Diagnostic indicators	6
	NIC indicator codes	6
	HDD Indicator codes	6
	Locating your system service tag	7
2	Documentation resources	8
3	Technical specifications.	10
	Processor specifications	10
	System battery specifications	10
	Expansion bus specifications	10
	Memory specifications	11
	Ports and connector specifications	11
	USB ports	11
	NIC ports	11
	DisplayPort	11
	Environmental specifications	12
	Temperature specifications.	12
	Relative humidity specifications	12
	Maximum vibration specifications	12
	Maximum shock specifications.	13
	Maximum altitude specifications	13
	Operating temperature de-rating specifications	13

	Particulate and gaseous contamination specifications	13
	Standard operating temperature specifications	14
	Expanded operating temperature specifications.	15
4	Initial system setup and configuration	16
	Setting up your system	16
	iDRAC configuration	16
	Options to set up iDRAC IP address	16
	Log in to iDRAC	17
	Options to install the operating system	18
	Methods to download firmware and drivers	18
	Downloading the drivers and firmware.	19
5	Pre-operating system management applications	20
	Options to manage the pre-operating system applications.	20
	System Setup	20
	System BIOS	21
	iDRAC Settings utility	45
	Device Settings	46
	Dell Lifecycle Controller.	46
	Embedded system management	46
	Boot Manager	47
	Viewing Boot Manager	47
	Boot Manager main menu	47
	One-shot BIOS boot menu	47
	System Utilities	47
	PXE boot	48
6	Installing and removing server components	49
	Safety instructions	49
	Before working inside your system	49
	After working inside your system	50

Recommended tools	50
System memory	51
General memory module installation guidelines	51
Mode-specific guidelines.	52
Memory optimized (independent channel) mode	52
Memory sparing	52
Memory mirroring.	52
Sample memory configurations	53
Removing memory module	54
Installing memory module	56
Processor and heat sink	58
Removing heat sink	58
Removing processor	60
Installing processor.	62
Installing heat sink	63
Expansion card and riser	66
Expansion card installation guidelines	66
Removing expansion card from slot 1	67
Installing expansion card into slot 1	68
Removing expansion card from slot 3	68
Installing expansion card into slot 3	68
Removing expansion card from slot 4	69
Installing expansion card into slot 4	69
Removing expansion card from slot 5	69
Installing expansion card into slot 5	70
Removing expansion card from slot 6	70
Installing expansion card into slot 6	71
System battery	71
Removing system battery.	71
Installing system battery	72
Hot swappable HDD cages	73
Installing hot swappable HDD cage	73
Removing hot swappable HDD cage	75
Hard drive	76
Removing 2.5-inch hard drive from the rear bay	76
Installing 2.5-inch hard drive in the rear bay.	78
Removing 3.5-inch hard drive from the rear bay	79

Installing 3.5-inch hard drive in the rear bay	82
Removing hot swappable hard drive	85
Installing hot swappable hard drive	87
Server board	89
Removing server board	89
Installing server board	92
Trusted platform module	95
Installing trusted platform module	95
Initializing TPM for BitLocker users	96
Initializing TPM for TXT users	96
Restoring the Service Tag by using the Easy Restore feature	97
Mini PERC battery	97
Removing Mini PERC battery	97
Installing Mini PERC battery	98
Supercap	99
Removing Microsemi supercap	99
Installing Microsemi supercap	101
Removing Broadcom supercap	103
Installing Broadcom supercap	104
Mezzanine card and Mini PERC	106
Removing mezzanine card	106
Installing mezzanine card	108
Removing Mini PERC	110
Installing Mini PERC	113
M.2 SSD	116
Removing x8 PCIe M.2 card	116
Installing x8 PCIe M.2 card	118
Removing x8 SATA M.2 card	121
Installing x8 SATA M.2 card	124
Removing x16 PCIe M.2 card	126
Installing x16 PCIe M.2 card	128
Removing x16 SATA M.2 card	130
Installing x16 SATA M.2 card	131
PCIe card	133
Removing PCIe card	133
Installing PCIe card	135

OCP card	138
Removing OCP card from slot 1	138
Installing OCP card into slot 1	140
Removing OCP card from slot 3	143
Installing OCP card into slot 3	145
3M riser card	147
Removing 3M riser card	147
Installing 3M riser card	149
NPIO card	153
Removing NPIO card from the rear bay	153
Installing NPIO card in the rear bay	155
Removing NPIO card from hot swappable bay	158
Installing NPIO card in hot swappable bay	160
NVMe riser	163
Removing NVMe riser	163
Installing NVMe riser	164
NPDB	166
Removing NPDB	166
Installing NPDB	167
Hard drive backplane	168
Removing HDD backplane	168
Installing HDD backplane	169
7 Using system diagnostics	171
Dell Embedded System Diagnostics	171
Running the Embedded System Diagnostics from Boot Manager	171
Running Embedded System Diagnostics from Lifecycle Controller	172
System diagnostic controls	172
8 Jumpers and connectors	173
9 Troubleshooting your system	175
Troubleshooting list	175

10 Getting help	176
Contacting Dell.	176
Documentation feedback	176

Overview

The DSS 9620 server contains a half-width chassis supporting the Intel® Xeon® Scalable platform. Each server supports up to two Intel® Xeon® Scalable processors.

NOTE: The product at time of delivery may differ from the following illustrations.

2.5-inch half-width server

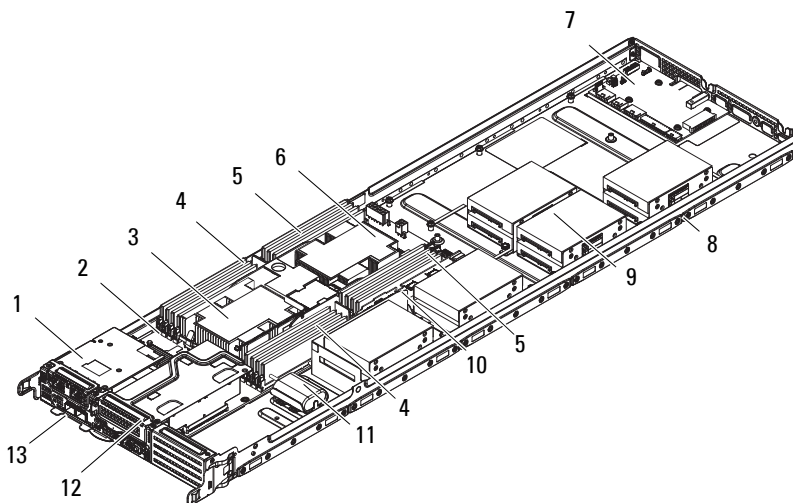

Figure 1. DSS 9620 2.5-inch half-width server

Table 1. DSS 9620 2.5-inch features

No.	Item	Description
1	Expansion port, slot 1	Supports x8 mezzanine expansion cards, connected to CPU 1.
2	Server board	Server board (DSS 9600M) with DDR4 DIMM slots.
3	CPU heat sink 1	Heat sink for CPU 1.
4	CPU 1 DIMMs	Memory modules for CPU 1. For more information, see System memory.

Table 1. DSS 9620 2.5-inch features (continued)

No.	Item	Description
5	CPU 2 DIMMs	Memory modules for CPU 2. For more information, see System memory.
6	CPU heat sink 2	Heat sink for CPU 2.
7	NPDB	Node power distribution board.
8	HW server chassis	Half-width server chassis for DSS 9620 server.
9	Server rear bay	Supports installation of up to ten 2.5-inch HDDs (HDD0—HDD9).
10	Expansion port, slot 5	Supports x16 PCIe expansion risers, connected to CPU 2.
11	Supercap	Supercap and holder for PCIe RAID card (Microsemi and Broadcom).
12	Expansion port, slot 4	Supports x16 PCIe expansion risers, connected to CPU 1.
13	Expansion port, slot 3	Supports x8 OCP expansion cards, connected to CPU 1.

3.5-inch half-width server

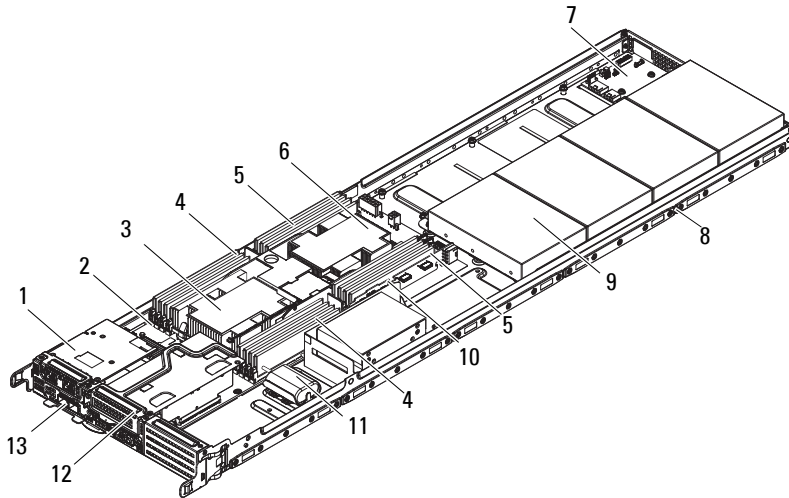

Figure 2. DSS 9620 3.5-inch half-width server

Table 2. DSS 9620 3.5-inch features

No.	Item	Description
1	Expansion port, slot 1	Supports x8 mezzanine expansion cards, connected to CPU 1.

Table 2. DSS 9620 3.5-inch features

No.	Item	Description
2	Server board	Server board (DSS 9600M) with DDR4 DIMM slots.
3	CPU heat sink 1	Heat sink for CPU 1.
4	CPU 1 DIMMs	Memory modules for CPU 1. For more information about memory modules, see System memory.
5	CPU 2 DIMMs	Memory modules for CPU 2. For more information about memory modules, see System memory.
6	CPU heat sink 2	Heat sink for CPU 2.
7	NPDB	Node power distribution board.
8	HW server chassis	Half width server chassis for DSS 9620 server.
9	Server rear bay	Supports installation of up to four 3.5-inch (HDD0—HDD3) and two 2.5-inch SSDs (SSD0—SSD1).
10	Expansion port, slot 5	Supports x16 PCIe risers, directly connected to CPU 2.
11	Supercap	Supercap and holder for PCIe RAID card (Microsemi and Broadcom).
12	Expansion port, slot 4	Supports x16 PCIe risers, connected to CPU 1.
13	Expansion port, slot 3	Supports x8 OCP expansion cards, connected to CPU 1.

System specifications

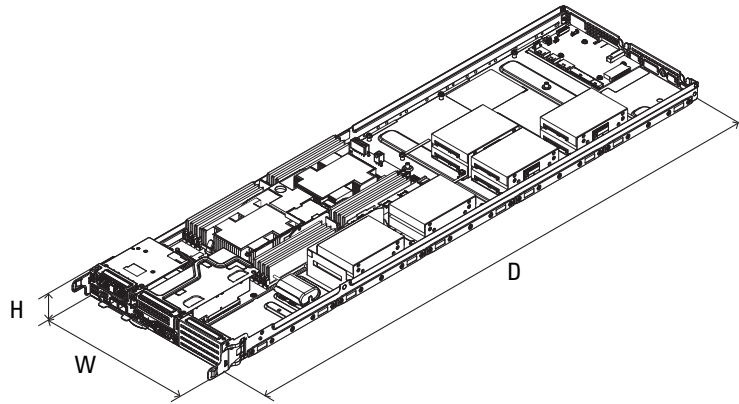

Figure 3. DSS 9620 dimensions

Table 3. DSS 9620 dimensions

Item	Description
Dimension (W x D x H)	262.20 mm x 930 mm x 47 mm (10.32 inch x 36.61 inch x 1.85 inch)
Weight	2.5-inch (fully loaded): 9.8 kg (21.60 lb)
	3.5-inch (fully loaded): 10.17 kg (22.42 lb)

Front-panel features

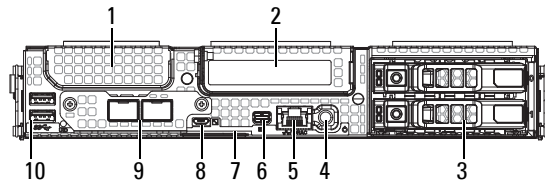

Figure 4. Front-panel features

Table 4. Front-panel features

No.	Item	Description
1	Expansion port, slot 1	Supports x8 mezzanine expansion cards. Connected to CPU 1.
2	Expansion port, slot 4	Supports x16 PCIe cards. Connected to CPU 1.
3	2.5-inch HDD	Two 2.5-inch hot swappable HDDs.
4	Power button	Press the power button to turn the server on or off. The indicator on the button indicates if the system is on or off.
5	LAN port	Single 10/100/1000 Mbps RJ-45 connector shared between 1G LAN and iDRAC management LAN.
6	DisplayPort	Single mini DisplayPort connector.
7	Service tag	Location of information tag specifying the system Service Tag.
8	iDRAC Direct micro USB port	The iDRAC Direct micro USB port enables you to connect a portable device to the server.
9	Expansion port, slot 3	Supports OCP expansion cards. Connected to CPU 1.
10	USB port	Two USB 3.0 compliant ports.

Diagnostic indicators

NIC indicator codes

Each NIC on the back panel has an indicator that provides information about the network activity and link status. The activity LED indicates whether data is flowing through NIC or not. The link LED indicates the speed of the connected network.

Table 5. NIC indicators

Convention	Status	Condition
A	Link and activity indicators are off	The NIC is not connected to the network.
B	Link indicator is green and activity indicator is blinking green	The NIC is connected to a valid network at its maximum port speed and data is being sent or received.
C	Link indicator is amber and activity indicator is blinking green	The NIC is connected to a valid network at less than its maximum port speed and data is being sent or received.
D	Link indicator is green and activity indicator is off	The NIC is connected to a valid network at its maximum port speed and data is not being sent or received.
E	Link indicator is amber and activity indicator is off	The NIC is connected to a valid network at less than its maximum port speed and data is not being sent or received.
F	Link indicator is blinking green and activity is off	NIC identify is enabled through the NIC configuration utility.

HDD Indicator codes

The expansion adapter has LED headers that correspond to access activity and link status.

PERC H330 Mini Mono, PERC H730P Mini Mono, PERC H730 and Broadcom 9361-8i

Table 6. PERC H330 Mini Mono, PERC H730P Mini Mono, PERC H730 and Broadcom 9361-8i

LED state	HDD state	Green LED	Amber LED
1	Empty	Off	Off
2	Online	On	Off
3	Identify/Prepare for removal	Blinking	Off
4	Rebuild	Blinking	Off
5	Fault	Off	Blinking

Locating your system service tag

Your system is identified by a unique Express Service Code and Service Tag number. The Express Service Code and Service Tag are found on the front of the system by pulling out the information tag. Alternatively, the information may be on a sticker on the chassis of the system. This information is used by Dell to route support calls to the appropriate personnel.

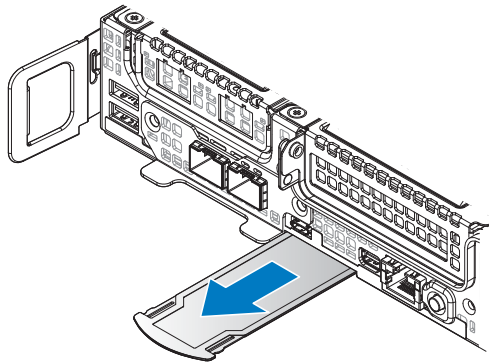

Figure 5. Service Tag location

Documentation resources

This section provides information about the documentation resources for your system.

Table 7. Additional documentation resources for your system

Task	Document	Location
Setting up your system	For information about installing the system into a rack, see the Rack documentation included with your rack solution.	Dell.com/dssmanuals
	For information about turning on the system and the technical specifications of your system, see the Getting Started With Your System document that is shipped with your system.	Dell.com/dssmanuals
Configuring your system	For information about the iDRAC features, configuring and logging in to iDRAC, and managing your system remotely, see the Integrated Dell Remote Access Controller User's Guide.	Dell.com/idracmanuals
	For information about installing the operating system, see the operating system documentation.	Dell.com/operatingsystemmanuals
	For information about understanding Remote Access Controller Admin (RACADM) subcommands and supported RACADM interfaces, see the RACADM Command Line Reference Guide for iDRAC.	Dell.com/idracmanuals
	For information about updating drivers and firmware, see the Methods to download firmware and drivers section in this document.	Dell.com/support/drivers
Managing your system	For information about systems management software offered by Dell, see the Dell OpenManage Systems Management Overview Guide.	Dell.com/openmanagemanuals
	For information about setting up, using, and troubleshooting OpenManage, see the Dell OpenManage Server Administrator User's Guide.	Dell.com/openmanagemanuals

Table 7. Additional documentation resources for your system (continued)

Task	Document	Location
	For information about installing, using, and troubleshooting Dell OpenManage Essentials, see the Dell OpenManage Essentials User's Guide.	Dell.com/openmanagemanuals
	For information about installing and using Dell SupportAssist, see the Dell EMC SupportAssist Enterprise User's Guide.	Dell.com/SupportAssist Enterprise
	For information about installing and using Active System Manager (ASM), see the Active System Manager User's Guide.	Dell.com/asmdocs
	For understanding the features of Dell Lifecycle Controller (LCC), see the Dell Lifecycle Controller User's Guide.	Dell.com/idracmanuals
	For information about partner programs enterprise systems management, see the OpenManage Connections Enterprise Systems Management documents.	Dell.com/omconnectionsenterprisesystemsmanagement
	For information about connections and client systems management, see the OpenManage Connections Client Systems Management documentation.	Dell.com/dellclientcommandsuitemanuals
	For information about viewing inventory, performing configuration and monitoring tasks, remotely turning on or off servers, and enabling alerts for events on servers and components using the Dell Chassis Management Controller (CMC), see the CMC User's Guide.	Dell.com/esmmanuals
Understanding event and error messages	For information about checking the event and error messages generated by the system firmware and agents that monitor system components, see the Dell Event and Error Messages Reference Guide.	Dell.com/openmanagemanuals > OpenManage software

Technical specifications

The technical and environmental specifications of your system are outlined in this section.

Processor specifications

The system is based on the Intel Xeon Processor Scalable Family and offers dual processor sockets.

System battery specifications

The system supports a CR 2032 3.0-V lithium coin cell system battery.

Expansion bus specifications

The system supports PCI express (PCIe) generation 3 expansion cards, which need to be installed on the server board using expansion card risers. The following is a list of supported expansion card risers.

Table 8. Expansion bus specification

PCIe slots	Description	Form factor
1	Dell mezzanine slot	x8
2	OCP	x8
3	OCP	x8
4	Main PCIe slot	x16 (PCIe low profile)
5	2 nd PCIe slot	x16 (PCIe low profile)
6	4 x NVMe slot	x16

Memory specifications

The system supports DDR4 registered DIMMs (RDIMMs) and Load Reduced DIMMs (LRDIMMs).

 **NOTE:** Maximum memory is processor dependent.

Table 9. Memory specifications

Memory module sockets	Memory type	Memory capacity	Minimum RAM	Maximum RAM
Sixteen DIMM sockets	RDIMM	512 GB	32 GB with dual processors (minimum one memory module per processor)	512 GB
	LRDIMM	2048 GB	64 GB with dual processors (minimum one memory module per processor)	1024 GB

 **NOTE:** Maximum available RAM is dependent on CPU SKU type.

Ports and connector specifications

USB ports

The system supports the following:

- USB 3.0-compliant ports internally and on the front panel

The following table provides more information about the USB specifications:

Table 10. USB specifications

Internal	Front panel
Two 4-pin, USB 3.0-compliant port	<ul style="list-style-type: none">• Two 4-pin, USB 3.0-compliant port• Micro-AB USB connector

NIC ports

The systems supports one embedded Network Interface Controller (NIC) port.

DisplayPort

The system supports one mini DisplayPort connector.

Environmental specifications



NOTE: For additional information about environmental measurements for specific system configurations, see Dell.com/environmental_datasheets.

Temperature specifications

Table 11. Temperature specifications

Temperature	Specifications
Storage	-40°C to 65°C (-40°F to 149°F)
Continuous operation (altitudes under 950 m / 3,117 ft)	10°C to 35°C (50°F to 95°F), avoiding direct sunlight.
Fresh air	For information about fresh air, see Expanded Operating Temperature section.
Maximum temperature gradient (operation and storage)	20°C/h (36°F/h)

Relative humidity specifications

Table 12. Relative humidity specifications

Temperature	Specifications
Storage	5% to 95% RH with 33°C (91°F) maximum dew point. Atmosphere must be non-condensing at all times.
Operating	10% to 80% relative humidity with 29°C (84.2°)

Maximum vibration specifications

Table 13. Maximum vibration specifications

Maximum vibration	Specifications
Operating	0.26 Grms at 5 Hz to 350 Hz (all operational orientations).
Storage	1.88 Grms at 10 Hz to 500 Hz for 15 min (all six sides tested).

Maximum shock specifications

Table 14. Maximum shock specifications

Maximum shock	Specifications
Operating	24 executed shock pulses 6 G in the positive and negative x, y, z axis up to 11 ms (four pulses on each side of the system).
Storage	Six consecutively executed shock pulses of 71 G in the positive and negative x, y, z axes up to 2 ms (one pulse on each side of the system).

Maximum altitude specifications

Table 15. Maximum altitude specifications

Temperature	Specifications
Operating	3,048 m (10,000 ft)
Storage	12,000 m (39,370 ft)

Operating temperature de-rating specifications

Table 16. Operating temperature de-rating specifications

Operating temperature de-rating	Specifications
Up to 35°C (95°F)	Maximum temperature is reduced by 1°C/300 m (1°F/547 ft) above 950 m (3,117 ft).
35°C to 40°C (95°F to 104°F)	Maximum temperature is reduced by 1°C/175 m (1°F/319 ft) above 950 m (3,117 ft).
40°C to 45°C (104°F to 113°F)	Maximum temperature is reduced by 1°C/125 m (1°F/228 ft) above 950 m (3,117 ft).

Related Links

[Expanded operating temperature]

Particulate and gaseous contamination specifications

The following table defines the limitations that help avoid any equipment damage or failure from particulates and gaseous contamination. If the levels of particulates or gaseous pollution exceed the specified limitations and result in equipment damage or failure, you may need to rectify the environmental conditions. Re-mediation of environmental conditions is the responsibility of the customer.

Table 17. Particulate contamination specifications







Particulate contamination	Specifications
Air filtration	<p>Data center air filtration as defined by ISO Class 8 per ISO 14644-1 with a 95% upper confidence limit.</p> <p> NOTE: This condition applies to data center environments only. Air filtration requirements do not apply to IT equipment designed to be used outside a data center, in environments such as an office or factory floor.</p> <p> NOTE: Air entering the data center must have MERV11 or MERV13 filtration.</p>
Conductive dust	<p>Air must be free of conductive dust, zinc whiskers, or other conductive particles.</p> <p> NOTE: This condition applies to data center and non-data center environments.</p>
Corrosive dust	<ul style="list-style-type: none"> • Air must be free of corrosive dust. • Residual dust present in the air must have a deliquescent point less than 60% relative humidity. <p> NOTE: This condition applies to data center and non-data center environments.</p>

Table 18. Gaseous contamination specifications

Gaseous contamination	Specifications
Copper coupon corrosion rate	<300 Å/month per Class G1 as defined by ANSI/ISA71.04-1985.
Silver coupon corrosion rate	<200 Å/month as defined by AHSRAE TC9.9.
	<p> NOTE: Maximum corrosive contaminant levels measured at ≤50% relative humidity.</p>



Standard operating temperature specifications

Table 19. Standard operating temperature specifications

Standard operating temperature	Specifications
Continuous operation (altitudes under 950 m / 3,117 ft)	10°C to 35°C (50°F to 95°F), avoiding direct sunlight.
	<p> NOTE: The system supports a maximum 165 W TDP.</p>

Expanded operating temperature specifications

Table 20. Expanded operating temperature specifications

Expanded operating temperature	Specifications
≤10% of annual operating hours	<p>5°C to 40°C (41°F to 104°F), avoiding direct sunlight on the equipment.</p> <p> NOTE: Outside the standard operating temperature (10°C to 35°C / 50°F to 95°F), the system can operate for a maximum of 10% of its annual operating hours in temperatures as low as 5°C (41°F) and as high as 40°C (104°F).</p> <p>For temperatures between 35°C and 40°C (95°F and 104°F), de-rate maximum allowable temperature by 1°C per 175 m above 950 m (1°F per 319 ft).</p> <p>–5°C to 45°C (23°F to 113°F) at 5% to 90% RH with 29°C (84°F) dew point.</p>
≤1% of annual operating hours	<p> NOTE: Outside the standard operating temperature (10°C to 35°C / 50°F to 95°F), the system can operate down to –5°C (23°F) or up to 45°C (113°F) for a maximum of 1% of its annual operating hours.</p> <p>For temperatures between 40°C and 45°C (104°F and 113°F), de-rate maximum allowable temperature by 1°C per 125 m above 950 m (1°F per 228 ft).</p>

 **NOTE:** When operating in the expanded temperature range, system performance may be impacted.

 **NOTE:** When operating in the expanded temperature range, ambient temperature warnings may be reported on the LCD panel and in the System Event Log.

Expanded operating temperature restrictions

- Do not perform a cold startup below 5°C (41°F).
- The specified operating temperature is based on a maximum altitude of 950 m (3,116 ft).
- PCIe Cards are not supported on slots 1, 2 and 3.
- A maximum of six hard drives are supported on half width systems with a 165 W processor.
- Redundant power supplies are required.
- Non-Dell qualified peripheral cards and/or peripheral cards greater than 25 W are not supported.

Initial system setup and configuration

Setting up your system

Complete the following steps to set up your system:

- 1 Unpack the system.
- 2 Install the system into the rack.
- 3 Connect the peripherals to the system.
- 4 Connect the system to its electrical outlet.
- 5 Turn the system on by pressing the power button or by using iDRAC.
- 6 Turn on the attached peripherals.

For more information about setting up your system, see your Getting Started Guide shipped with your system.

Related links

- [iDRAC configuration](#)
- [Options to install the operating system](#)

iDRAC configuration

The Integrated Dell Remote Access Controller (iDRAC) is designed to make system administrators more productive and improve the overall availability of Dell systems. iDRAC alerts administrators to system issues, helps them perform remote system management, and reduces the need for physical access to the system.

Options to set up iDRAC IP address

You must configure the initial network settings based on your network infrastructure to enable the communication to and from iDRAC.

You must use the default iDRAC IP address 192.168.0.120 to configure the initial network settings, including setting up DHCP or a static IP for iDRAC. You can set up the IP address by using one of the following interfaces:

Table 21. Options to set up iDRAC IP address

Interfaces	Document/Section
iDRAC Settings utility	See Dell Integrated Dell Remote Access Controller User's Guide at Dell.com/idracmanuals
Dell Deployment Toolkit	See Dell Deployment Toolkit User's Guide at Dell.com/openmanagemanuals
Remote Access Controller Admin (RACADM)	See RACADM Command Line Interface Reference Guide and Integrated Dell Remote Access Controller User's Guide at Dell.com/idracmanuals
Remote Services that include Web Services Management (WS-Man)	See Dell Integrated Dell Remote Access Controller User's Guide at Dell.com/idracmanuals
Dell Lifecycle Controller	See Dell Lifecycle Controller User's Guide at Dell.com/idracmanuals

 **NOTE:** To access iDRAC, ensure that you connect the network cable to the Ethernet port in shared mode or the iDRAC Management port on the server board.

 **NOTE:** To access iDRAC connect the network cable to the Ethernet connector on the server board.

 **NOTE:** To access iDRAC, ensure that you install the iDRAC port card or connect the network cable to the Ethernet connector 1 on the server board.

 **NOTE:** To access BMC, ensure that you install the remote management port card or connect the network cable to the Ethernet connector 1 on the server board.

Log in to iDRAC

You can log in to iDRAC as:

- iDRAC user
- Microsoft Active Directory user
- Lightweight Directory Access Protocol (LDAP) user

If you have opted for secure default access to iDRAC, the system Information tag contains the iDRAC secure default password. If you have not opted for secure default access to iDRAC, then the default user name and password are `root` and `calvin`. You can also log in by using Single Sign-On or Smart Card.

 **NOTE:** You must have iDRAC credentials to log in to iDRAC.

 **NOTE:** Ensure that you change the default user name and password after setting up the iDRAC IP address.

For more information about logging in to iDRAC and iDRAC licenses, see the latest Integrated Dell Remote Access Controller User's Guide at Dell.com/idracmanuals.

You can also access iDRAC by using RACADM. For more information, see the RACADM Command Line Interface Reference Guide and the Integrated Dell Remote Access Controller User's Guide at Dell.com/idracmanuals.

Options to install the operating system

If the system is shipped without an operating system, install the supported operating system by using one of the following resources:

Table 22. Resources to install the operating system

Resources	Location
Dell Systems Management Tools and Documentation media	Dell.com/operatingsystemmanuals
Dell Lifecycle Controller	Dell.com/idracmanuals
Dell OpenManage Deployment Toolkit	Dell.com/openmanagemanuals
Dell certified VMware ESXi	Dell.com/virtualizationsolutions
Installation and How-to videos for supported operating systems on Dell PowerEdge systems	Supported Operating Systems for Dell PowerEdge Systems

Methods to download firmware and drivers

You can download the firmware and drivers by using any of the following methods:

Table 23. Firmware and drivers

Methods	Location
From the Dell Support site	Dell.com/support/home
Using Dell Remote Access Controller Lifecycle Controller (iDRAC with LC)	Dell.com/idracmanuals
Using BMC	Dell.com/idracmanuals
Using Dell Repository Manager (DRM)	Dell.com/openmanagemanuals
Using Dell Server Update Utility (SUU)	Dell.com/openmanagemanuals
Using Dell OpenManage Deployment Toolkit (DTK)	Dell.com/openmanagemanuals

You can download the firmware and drivers from the Dell support site at Dell.com/support/home.

Downloading the drivers and firmware

Dell recommends that you download and install the latest BIOS, drivers, and systems management firmware on your system which is listed in Dell Hyperconverged Infrastructure with Microsoft Software Defined Stack Support Matrix.

Prerequisites

Ensure that you clear the web browser cache before downloading the drivers and firmware.

Steps

- 1 Go to Dell.com/support/drivers.
- 2 In the Drivers & Downloads section, type the Service Tag of your system in the **Service Tag or Express Service Code** box, and then click **Submit**.



NOTE: If you do not have the Service Tag, select Detect Product to allow the system to automatically detect your Service Tag, or click View products, and navigate to your product.

- 3 Click **Drivers & Downloads**.

The drivers that are applicable to your selection are displayed.

- 4 Download the drivers to a USB drive, CD, or DVD.

Pre-operating system management applications

You can manage basic settings and features of a system without booting to the operating system by using the system firmware.

Options to manage the pre-operating system applications

Your system has the following options to manage the pre-operating system applications:

- System Setup
- Boot Manager
- Dell Lifecycle Controller
- Preboot Execution Environment (PXE)

System Setup

By using the **System Setup** screen, you can configure the BIOS settings, iDRAC settings, BMC settings, and device settings of your system.

 **NOTE:** Help text for the selected field is displayed in the graphical browser by default. To view the help text in the text browser, press F1.

You can access system setup by using two methods:

- Standard graphical browser — The browser is enabled by default.
- Text browser — The browser is enabled by using Console Redirection.

Viewing System Setup

To view the System Setup screen, perform the following steps:

- 1 Turn on, or restart your system.
- 2 Press F2 immediately after you see the following message:
F2 = System Setup

 **NOTE:** If your operating system begins to load before you press F2, wait for the system to finish booting, and then restart your system and try again.

System Setup details

The System Setup Main Menu screen details are explained as follows:

Table 24. System Setup Main Menu

Option	Description
System BIOS	Enables you to configure BIOS settings.
iDRAC Settings	Enables you to configure the iDRAC settings. The iDRAC settings utility is an interface to set up and configure the iDRAC parameters by using UEFI (Unified Extensible Firmware Interface). You can enable or disable various iDRAC parameters by using the iDRAC settings utility. For more information about this utility, see Integrated Dell Remote Access Controller User's Guide at Dell.com/idracmanuals .
iDRAC Settings	Enables you to configure BMC settings. The iDRAC settings utility is an interface to set up and configure the BMC parameters by using UEFI. You can enable or disable various BMC parameters by using the iDRAC settings utility. For more information about this utility, see Integrated Dell Remote Access Controller 8 User's Guide at Dell.com/idracmanuals .
Device Settings	Enables you to configure device settings.

System BIOS

You can use the System BIOS screen to edit specific functions such as boot order, system password, setup password, set the RAID mode, and enable or disable USB ports.

Viewing System BIOS

To view the System BIOS screen, perform the following steps:

- 1** Turn on, or restart your system.
- 2** Press F2 immediately after you see the following message:

F2 = System Setup



NOTE: If your operating system begins to load before you press F2, wait for the system to finish booting, and then restart your system and try again.

- 3** On the System Setup Main Menu screen, click System BIOS.

System BIOS Settings details

The System BIOS Settings screen details are explained as follows:

Table 25. System BIOS Settings

Option	Description
System Information	Specifies information about the system such as the system model name, BIOS version, and Service Tag.
Memory Settings	Specifies information and options related to the installed memory.
Processor Settings	Specifies information and options related to the processor such as speed and cache size.
SATA Settings	Specifies options to enable or disable the integrated SATA controller and ports.
NVMe Settings	Specifies options to change the NVMe settings.
Boot Settings	Specifies options to specify the Boot mode (BIOS or UEFI). Enables you to modify UEFI and BIOS boot settings.
Network Settings	Specifies options to change the network settings.
Integrated Devices	Specifies options to manage integrated device controllers and ports and specify related features and options.
System Profile Settings	Specifies options to change the processor power management settings, memory frequency, and so on.
System Security	Specifies options to configure the system security settings, such as system password, setup password, Trusted Platform Module (TPM) security. It also manages the power button on the system.
Redundant OS Settings	Specifies the options to configure the Redundant OS settings.
Miscellaneous Settings	Specifies options to change the system date, time, and so on.
Debug Menu	Specifies the debug options.

Boot Settings

You can use the **Boot Settings** screen to set the boot mode to either **BIOS** or **UEFI**. It also enables you to specify the boot order.

- **UEFI:** The Unified Extensible Firmware Interface (UEFI) is a new interface between operating systems and platform firmware. The interface consists of data tables with platform related information, also boot and runtime service calls that are available to the operating system and its loader. The following benefits are available when the **Boot Mode** is set to **UEFI**:
 - Support for hard drive partitions are larger than 2 TB.
 - Enhanced security (e.g., UEFI Secure Boot).
 - Faster boot time.
- **BIOS:** The Basic Input/output System (BIOS) is a firmware embedded on the server board. When the system is first started, BIOS activates all of the hardware required by the system to boot including chipset, processor and cache, system memory, internal drives, graphics and audio controllers, and internal expansion cards. After BIOS completes this process, it transfers control of the system to the Operating System that is installed. The method this transfer occurs is controlled by the **BIOS Boot Mode**, available options being **BIOS** and **UEFI**. The **BIOS Boot Mode** is the legacy boot mode. It is maintained for backward compatibility.

Viewing Boot Settings

To view the **Boot Settings** screen, perform the following steps:

- 1 Turn on, or restart your system.
- 2 Press F2 immediately after you see the following message:
F2 = System Setup







NOTE: If your operating system begins to load before you press F2, wait for the system to finish booting, and then restart your system and try again.

- 3 On the **System Setup Main Menu** screen, click **System BIOS**.
- 4 On the **System BIOS** screen, click **Boot Settings**.

Boot Settings details

The **Boot Settings** screen details are explained as follows:

Table 26. Boot Settings

Option	Description
Boot Mode	<p>Enables you to set the boot mode of the system.</p> <p> CAUTION: Switching the boot mode may prevent the system from booting if the operating system is not installed in the same boot mode.</p> <p>If the operating system supports UEFI, you can set this option to UEFI. Setting this field to BIOS allows compatibility with non-UEFI operating systems. This option is set to BIOS by default.</p> <p> NOTE: Setting this field to UEFI disables the BIOS Boot Settings menu. Setting this field to BIOS disables the UEFI Boot Settings menu.</p>
Boot Sequence Retry	<p>Enables or disables the Boot Sequence Retry feature. If this option is set to Enabled and the system fails to boot, the system re-attempts the boot sequence after 30 seconds. This option is set to Enabled by default.</p>
Hard-Disk Failover	<p>Specifies the hard drive that is booted in the event of a hard drive failure. The devices are selected in the Hard-Disk Drive Sequence on the Boot Option Setting menu. When this option is set to Disabled, only the first hard drive in the list is attempted to boot. When this option is set to Enabled, all hard drives are attempted to boot in the order selected in the Hard-Disk Drive Sequence. This option is not enabled for UEFI Boot Mode.</p>
Boot Option Settings	<p>Configures the boot sequence and the boot devices.</p>
BIOS Boot Settings	<p>Enables or disables BIOS boot options.</p> <p> NOTE: This option is enabled only if the boot mode is BIOS.</p>
UEFI Boot Settings	<p>Enables or disables UEFI Boot options. The UEFI options include PXE boot devices.</p> <p> NOTE: This option is enabled only if the boot mode is UEFI.</p>
UEFI Boot Sequence	<p>Enables you to change the PXE boot device order.</p>
Boot Options Enable/Disable	<p>Enables you to select the enabled or disabled PXE devices.</p>

Choosing system boot mode

System Setup enables you to specify one of the following boot modes for installing your operating system:

- BIOS boot mode (the default) is the standard BIOS-level boot interface.
- UEFI (the default) boot mode, is an enhanced 64-bit boot interface. If you have configured your system to boot to UEFI mode, it replaces the system BIOS.

 **NOTE:** The system supports only BIOS boot mode.

- 1 From the **System Setup Main Menu**, click **Boot Settings**, and select **Boot Mode**.
- 2 Select the UEFI boot mode you want the system to boot into.

 **CAUTION:** Switching the boot mode may prevent the system from booting if the operating system is not installed in the same boot mode.

- 3 After the system boots in the specified boot mode, proceed to install your operating system from that mode.

 **NOTE:** Operating systems must be UEFI-compatible to be installed from the UEFI boot mode. DOS and 32-bit operating systems do not support UEFI and can only be installed from the BIOS boot mode.

 **NOTE:** For the latest information about supported operating systems, go to Dell.com/ossupport.

Changing boot order

About this task

Dell EMC does not recommend changing boot order. You may have to change the boot order if you want to boot from a USB key. You may have to change the boot order if you want to boot from a USB key or an optical drive. The following instructions may vary if you have selected **BIOS** for **Boot Mode**.

Steps

- 1 On the **System Setup Main Menu** screen, click **System BIOS > Boot Settings**.
- 2 Click **Boot Option Settings > BIOS/UEFI Boot Settings > Boot Sequence**.
- 3 Use the arrow keys to select a boot device, and use the plus (+) and minus (-) sign keys to move the device down or up in the order.
- 4 Click **Exit**, and then click **Yes** to save the settings on exit.

Network Settings

You can use the **Network Settings** screen to modify PXE device settings. The network settings option is available only in the UEFI mode.

 **NOTE:** The BIOS does not control network settings in the BIOS mode. For the BIOS boot mode, the optional Boot ROM of the network controllers handles the network settings.

Viewing Network Settings

To view the **Network Settings** screen, perform the following steps:

- 1 Turn on, or restart your system.
- 2 Press F2 immediately after you see the following message:
F2 = System Setup

 **NOTE:** If your operating system begins to load before you press F2, wait for the system to finish booting, and then restart your system and try again.

- 3 On the System Setup Main Menu screen, click System BIOS.
- 4 On the System BIOS screen, click Network Settings.

Network Settings screen details

The Network Settings screen details are explained as follows:

Table 27. Network Settings

Option	Description
PXE Device n (n = 1 to 4)	Enables or disables the device. When enabled, a UEFI boot option is created for the device.
PXE Device n Settings (n = 1 to 4)	Enables you to control the configuration of the PXE device.
UEFI HTTP Device n Settings (n = 1 to 3)	Enables or disables the UEFI HTTP device settings.

UEFI iSCSI Settings

You can use the iSCSI Settings screen to modify iSCSI device settings. The iSCSI Settings option is available only in the UEFI boot mode. BIOS does not control network settings in the BIOS boot mode. For the BIOS boot mode, the option ROM of the network controller handles the network settings.

Viewing UEFI iSCSI Settings

To view the UEFI iSCSI Settings screen, perform the following steps:

- 1 Turn on, or restart your system.
- 2 Press F2 immediately after you see the following message:
F2 = System Setup



NOTE: If your operating system begins to load before you press F2, wait for the system to finish booting, and then restart your system and try again.

- 3 On the System Setup Main Menu screen, click System BIOS.
- 4 On the System BIOS screen, click Network Settings.
- 5 On the Network Settings screen, click UEFI iSCSI Settings.

UEFI iSCSI Settings details

The UEFI iSCSI Settings screen details are explained as follows:

Table 28. UEFI iSCSI Settings

Option	Description
iSCSI Initiator Name	Specifies the name of the iSCSI initiator (iqn format).

Table 28. UEFI iSCSI Settings (continued)

Option	Description
ISCSI Device n (n = 1 to 4)ISCSI Device1	Enables or disables the iSCSI device. When disabled, a UEFI boot option is created for the iSCSI device automatically.

System Security

You can use the **System Security** screen to perform specific functions such as setting the system password, setup password and disabling the power button.

Viewing System Security

To view the **System Security** screen, perform the following steps:

- 1 Turn on, or restart your system.
- 2 Press F2 immediately after you see the following message:
F2 = System Setup



NOTE: If your operating system begins to load before you press F2, wait for the system to finish booting, and then restart your system and try again.

- 3 On the **System Setup Main Menu** screen, click **System BIOS**.
- 4 On the **System BIOS** screen, click **System Security**.

System Security Settings details

The **System Security Settings** screen details are explained as follows:

Table 29. System Security Settings

Option	Description
Intel AES-NI	Improves the speed of applications by performing encryption and decryption by using the Advanced Encryption Standard Instruction Set (AES-NI). This option is set to Enabled by default.
System Password	Sets the system password. This option is set to Enabled by default and is read-only if the password jumper is not installed in the system.
Setup Password	Sets the setup password. This option is read-only if the password jumper is not installed in the system.
Password Status	Locks the system password. This option is set to Unlocked by default.
TPM Security	 NOTE: The TPM menu is available only when the TPM module is installed. Enables you to control the reporting mode of the TPM. The TPM Security option is set to Off by default. You can only modify the TPM Status, TPM Activation, and the Intel TXT fields if the TPM Status field is set to either On with Pre-boot Measurements or On without Pre-boot Measurements .

Table 29. System Security Settings (continued)

Option	Description
TPM Information	Changes the operational state of the TPM. This option is set to No Change by default.
TPM Status	Specifies the TPM status.
TPM Command	Clears all the contents of the TPM. The TPM Clear option is set to No by default.
 CAUTION: Clearing the TPM results in the loss of all keys in the TPM. The loss of TPM keys may affect booting to the operating system.	
Intel TXT	Enables or disables the Intel Trusted Execution Technology (TXT) option. To enable the Intel TXT option, virtualization technology and TPM Security must be enabled with Pre-boot measurements. This option is set to Off by default.
Power Button	Enables or disables the power button on the front of the system. This option is set to Enabled by default.
AC Power Recovery	Sets how the system behaves after AC power is restored to the system. This option is set to Last by default.
AC Power Recovery Delay	Sets the time delay for the system to power up after AC power is restored to the system. This option is set to Immediate by default.
User Defined Delay (60 s to 240 s)	Sets the User Defined Delay option when the User Defined option for AC Power Recovery Delay is selected.
UEFI Variable Access	Provides varying degrees of securing UEFI variables. When set to Standard (the default), UEFI variables are accessible in the operating system per the UEFI specification. When set to Controlled , selected UEFI variables are protected in the environment and new UEFI boot entries are forced to be at the end of the current boot order.
Secure ME PCI Cfg Space	Enabling this setting will hide the PCI configuration space for the Management Engine (ME) HECI devices.
Secure Boot	Enables Secure Boot, where the BIOS authenticates each pre-boot image by using the certificates in the Secure Boot Policy. Secure Boot is disabled by default.
Secure Boot Policy	When Secure Boot policy is set to Standard , the BIOS uses the system manufacturer's key and certificates to authenticate pre-boot images. When Secure Boot policy is set to Custom , the BIOS uses the user-defined key and certificates. Secure Boot policy is set to Standard by default.

Table 29. System Security Settings (continued)

Option	Description
Secure Boot Mode	<p>Configures how the BIOS uses the Secure Boot Policy Objects (PK, KEK, db, dbx).</p> <ul style="list-style-type: none">• User Mode: In User Mode, PK must be installed, and BIOS performs signature verification on programmatic attempts to update policy objects. The BIOS allows unauthenticated programmatic transitions between modes.• Audit Mode: In Audit Mode, PK is not present. The BIOS does not authenticate programmatic updates to the policy objects, and transitions between modes. Audit Mode is useful for programmatically determining a working set of policy objects. BIOS performs signature verification on pre-boot images and logs results in the image Execution Information Table, but executes the images whether they pass or fail verification.• Deployed Mode: Deployed Mode is the most secure mode. In Deployed Mode, PK must be installed and the BIOS performs signature verification on programmatic attempts to update policy objects. Deployed Mode restricts the programmatic mode transitions
Secure Boot Policy Summary	Specifies the list of certificates and hashes that secure boot uses to authenticate images.
Secure Boot Custom Policy Settings	Configures the Secure Boot Custom Policy.

Creating a system and setup password

Prerequisites

Ensure that the password jumper is enabled. The password jumper enables or disables the system password and setup password features. For more information, see the Server board jumper settings section.



NOTE: If the password jumper setting is disabled, the existing system password and setup password are deleted and you need not provide the system password to boot the system.

Steps

- 1 To enter System Setup, press F2 immediately after turning on or rebooting your system.
- 2 On the **System Setup Main Menu** screen, click **System BIOS > System Security**.
- 3 On the **System Security** screen, verify that **Password Status** is set to **Unlocked**.
- 4 In the **System Password** field, type your system password, and press Enter or Tab.
Use the following guidelines to assign the system password:
 - A password can have up to 32 characters.
 - The password can contain the numbers 0 through 9.

- Only the following special characters are allowed: space, (?h), (+), (,), (-), (.), (/), (:), ([), (\), (]), (^).

A message prompts you to reenter the system password.⁵

- 5 Reenter the system password, and click **OK**.

In the **Setup Password** field, type your setup password and press Enter or Tab.

- 6 A message prompts you to reenter the setup password.

- 7 Reenter the setup password, and click **OK**.

- 8 Press Esc to return to the System BIOS screen. Press Esc again.

A message prompts you to save the changes.

 **NOTE:** Password protection does not take effect until the system reboots.

Using your system password to secure your system

About this task

If you have assigned a setup password, the system accepts your setup password as an alternate system password.

Steps

- 1 Turn on or reboot your system.
- 2 Type the system password and press Enter.

Next steps

When **Password Status** is set to **Locked**, type the system password and press Enter when prompted at reboot.

 **NOTE:** If an incorrect system password is typed, the system displays a message and prompts you to reenter your password. You have three attempts to type the correct password. After the third unsuccessful attempt, the system displays an error message that the system has stopped functioning and must be turned off. Even after you turn off and restart the system, the error message is displayed until the correct password is entered.

Deleting or changing system and setup password

Prerequisites

 **NOTE:** You cannot delete or change an existing system or setup password if the Password Status is set to Locked.

Steps

- 1 To enter System Setup, press F2 immediately after turning on or restarting your system.
- 2 On the **System Setup Main Menu** screen, click **System BIOS > System Security**.
- 3 On the **System Security** screen, ensure that **Password Status** is set to **Unlocked**.
- 4 In the **System Password** field, alter or delete the existing system password, and then press Enter or Tab.

- 5 In the **Setup Password** field, alter or delete the existing setup password, and then press Enter or Tab. If you change the system and setup password, a message prompts you to reenter the new password. If you delete the system and setup password, a message prompts you to confirm the deletion.
- 6 Press Esc to return to the **System BIOS** screen. Press Esc again, and a message prompts you to save the changes.
- 7 Select **Setup Password**, change, or delete the existing setup password and press Enter or Tab.

 **NOTE:** If you change the system password or setup password, a message prompts you to reenter the new password. If you delete the system password or setup password, a message prompts you to confirm the deletion.

Operating with setup password enabled

If **Setup Password** is set to **Enabled**, type the correct setup password before modifying the system setup options.

If you do not type the correct password in three attempts, the system displays the following message:

```
Invalid Password! Number of unsuccessful password attempts: <x> System  
Halted! Must power down.
```

```
Password Invalid. Number of unsuccessful password attempts: <x> Maximum  
number of password attempts exceeded. System halted.
```

Even after you turn off and restart the system, the error message is displayed until the correct password is typed. The following options are exceptions:

- If **System Password** is not set to **Enabled** and is not locked through the **Password Status** option, you can assign a system password. For more information, see the System Security Settings screen section.
- You cannot disable or change an existing system password.

 **NOTE:** You can use the password status option with the setup password option to protect the system password from unauthorized changes.

System Information

You can use the **System Information** screen to view system properties such as Service Tag, system model name, and the BIOS version.

Viewing System Information

To view the **System Information** screen, perform the following steps:

- 1 Turn on, or restart your system.
- 2 Press F2 immediately after you see the following message:
F2 = System Setup

 **NOTE:** If your operating system begins to load before you press F2, wait for the system to finish booting, and then restart your system and try again.

- 3 On the **System Setup Main Menu** screen, click **System BIOS**.
- 4 On the **System BIOS** screen, click **System Information**.

System Information details

The **System Information** screen details are explained as follows:

Table 30. System Information

Option	Description
System Model Name	Specifies the system model name.
System BIOS Version	Specifies the BIOS version installed on the system.
System Management Engine Version	Specifies the current version of the Management Engine firmware.
System Service Tag	Specifies the system Service Tag.
System Manufacturer	Specifies the name of the system manufacturer.
System Manufacturer Contact Information	Specifies the contact information of the system manufacturer.
System CPLD Version	Specifies the current version of the system complex programmable logic device (CPLD) firmware.
UEFI Compliance Version	Specifies the UEFI compliance level of the system firmware.

Memory Settings

You can use the **Memory Settings** screen to view all the memory settings and enable or disable specific memory functions, such as system memory testing and node interleaving.

Viewing Memory Settings

To view the **Memory Settings** screen, perform the following steps:

- 1 Turn on, or restart your system.
- 2 Press F2 immediately after you see the following message:
F2 = System Setup





NOTE: If your operating system begins to load before you press F2, wait for the system to finish booting, and then restart your system and try again.

- 3 On the **System Setup Main Menu** screen, click **System BIOS**.
- 4 On the **System BIOS** screen, click **Memory Settings**.

Memory Settings details

The **Memory Settings** screen details are explained as follows:

Table 31. Memory Settings

Option	Description
System Memory Size	Specifies the memory size in the system.
System Memory Type	Specifies the type of memory installed in the system.
System Memory Speed	Specifies the system memory speed.
System Memory Voltage	Specifies the system memory voltage.
Video Memory	Specifies the amount of video memory.
System Memory Testing	Specifies whether the system memory tests are run during system boot. Options are Enabled and Disabled . This option is set to Disabled by default.
Memory Operating Mode	Specifies the memory operating mode. The available option is Optimizer Mode .
Memory Operating Mode	Specifies the memory operating mode. The options available are Optimizer Mode , Single Rank Spare Mode , Multi Rank Spare Mode , Mirror Mode , and Dell Fault Resilient Mode . This option is set to Optimizer Mode by default.  NOTE: The Memory Operating Mode option can have different default and available options based on the memory configuration of your system.  NOTE: The Dell Fault Resilient Mode option establishes an area of memory that is fault resilient. This mode can be used by an operating system that supports the feature to load critical applications or enables the operating system kernel to maximize system availability.
Memory Operating Mode	Specifies the memory operating mode. The options available are Optimizer Mode , Advanced ECC Mode , Mirror Mode , Spare Mode , Spare with Advanced ECC Mode . This option is set to Optimizer Mode by default.  NOTE: The Memory Operating Mode option can have different default and available options based on the memory configuration of your system.
Current State of Memory Operating Mode	Specifies the current state of the memory operating mode.
Node Interleaving	Specifies if Non-Uniform Memory Architecture (NUMA) is supported. If this field is set to Enabled , memory interleaving is supported if a symmetric memory configuration is installed. If the field is set to Disabled , the system supports NUMA (asymmetric) memory configurations. This option is set to Disabled by default.
Snoop Mode	Specifies the Snoop Mode options. The Snoop Mode options available are Home Snoop , Early Snoop , and Cluster on Die . This option is set to Early Snoop by default. This field is available only when the Node Interleaving is set to Disabled .

Processor Settings

You can use the **Processor Settings** screen to view the processor settings, and perform specific functions such as enabling virtualization technology, hardware prefetcher, logical processor idling, and opportunistic self-refresh.

Viewing Processor Settings

To view the **Processor Settings** screen, perform the following steps:

- 1 Turn on, or restart your system.
- 2 Press F2 immediately after you see the following message:

F2 = System Setup



NOTE: If your operating system begins to load before you press F2, wait for the system to finish booting, and then restart your system and try again.

- 3 On the **System Setup Main Menu** screen, click **System BIOS**.
- 4 On the **System BIOS** screen, click **Processor Settings**.



Processor Settings details

The **Processor Settings** screen details are explained as follows:

Table 32. Processor Settings

Option	Description
Logical Processor	Enables or disables the logical processors and displays the number of logical processors. If this option is set to Enabled , the BIOS displays all the logical processors. If this option is set to Disabled , the BIOS displays only one logical processor per core. This option is set to Enabled by default.
Virtualization Technology	Enables or disables the virtualization technology for the processor. This option is set to Enabled by default.
Adjacent Cache Line Prefetch	Optimizes the system for applications that need high utilization of sequential memory access. This option is set to Enabled by default. You can disable this option for applications that need high utilization of random memory access.
Hardware Prefetcher	Enables or disables the hardware prefetcher. This option is set to Enabled by default.
DCU Streamer Prefetcher	Enables or disables the Data Cache Unit (DCU) streamer prefetcher. This option is set to Enabled by default.
DCU IP Prefetcher	Enables or disables the Data Cache Unit (DCU) IP prefetcher. This option is set to Enabled by default.
Sub NUMA Cluster	Enables or disables the Sub NUMA Cluster. This option is set to Enabled by default.

Table 32. Processor Settings (continued)

Option	Description
Logical Processor Idling	Enables you to improve the energy efficiency of a system. It uses the operating system core parking algorithm and parks some of the logical processors in the system which in turn allows the corresponding processor cores to transition into a lower power idle state. This option can only be enabled if the operating system supports it. It is set to Disabled by default.
Configurable TDP	Enables you to reconfigure the processor Thermal Design Power (TDP) levels during POST based on the power and thermal delivery capabilities of the system. TDP verifies the maximum heat the cooling system is needed to dissipate. This option is set to Nominal by default.  NOTE: This option is only available on certain stock keeping units (SKUs) of the processors.
X2Apic Mode	Enables or disables the X2Apic mode.
Dell Controlled Turbo	Controls the turbo engagement. Enable this option only when System Profile is set to Performance .  NOTE: Depending on the number of installed CPUs, there may be up to four processor listings.
X2Apic Mode	Displays the X2Apic Mode setting that is read only and permanently set to enabled.
Number of Cores per Processor	Controls the number of enabled cores in each processor. This option is set to All by default.
Processor Core Speed	Specifies the maximum core frequency of the processor.
Processor 1	 NOTE: Depending on the number of CPUs, there may be up to four processors listed. The following settings are displayed for each processor installed in the system: <ul style="list-style-type: none"> • Family-Model-Stepping: Specifies the family, model, and stepping of the processor as defined by Intel. • Brand: Specifies the brand name. • Level 2 Cache: Specifies the total L2 cache. • Level 3 Cache: Specifies the total L3 cache. • Number of Cores: Specifies the number of cores per processor.

SATA Settings

You can use the **SATA Settings** screen to view the SATA settings of SATA devices.

Viewing SATA Settings

To view the **SATA Settings** screen, perform the following steps:

- 1 Turn on, or restart your system.
- 2 Press F2 immediately after you see the following message:
F2 = System Setup

 **NOTE:** If your operating system begins to load before you press F2, wait for the system to finish booting, and then restart your system and try again.

- 3 On the System Setup Main Menu screen, click System BIOS.
- 4 On the System BIOS screen, click SATA Settings.

SATA Settings details

The SATA Settings screen details are explained as follows:

Table 33. SATA Settings

Option	Description
Embedded SATA	Enables the embedded SATA option to be set to AHCI , or RAID modes. This option is set to AHCI by default.
Security Freeze Lock	Sends Security Freeze Lock command to the embedded SATA drives during POST. This option is applicable only for ATA and AHCI mode.
Write Cache	Enables or disables the command for the embedded SATA drives during POST.
Port A	<p>Sets the drive type of the selected device. For the Embedded SATA settings in ATA mode, set this field to Auto to enable BIOS support. Set it to OFF to turn off BIOS support.</p> <p>For AHCI mode, BIOS support is always enabled.</p> <ul style="list-style-type: none"> • Model: Specifies the drive model of the selected device. • Drive Type: Specifies the type of drive attached to the SATA port. • Capacity: Specifies the total capacity of the hard drive. This field is undefined for removable media devices such as optical drives.
Port B	<p>Sets the drive type of the selected device. For the Embedded SATA settings in ATA mode, set this field to Auto to enable BIOS support. Set it to OFF to turn off BIOS support.</p> <p>For AHCI mode, BIOS support is always enabled.</p> <ul style="list-style-type: none"> • Model: Specifies the drive model of the selected device. • Drive Type: Specifies the type of drive attached to the SATA port. • Capacity: Specifies the total capacity of the hard drive. This field is undefined for removable media devices such as optical drives.

Table 33. SATA Settings (continued)

Option	Description
Port C	<p>Sets the drive type of the selected device. For the Embedded SATA settings in ATA mode, set this field to Auto to enable BIOS support. Set it to OFF to turn off BIOS support.</p> <p>For AHCI mode, BIOS support is always enabled.</p> <ul style="list-style-type: none">• Model: Specifies the drive model of the selected device.• Drive Type: Specifies the type of drive attached to the SATA port.• Capacity: Specifies the total capacity of the hard drive. This field is undefined for removable media devices such as optical drives.
Port D	<p>Sets the drive type of the selected device. For the Embedded SATA settings in ATA mode, set this field to Auto to enable BIOS support. Set it to OFF to turn off BIOS support.</p> <p>For AHCI mode, BIOS support is always enabled.</p> <ul style="list-style-type: none">• Model: Specifies the drive model of the selected device.• Drive Type: Specifies the type of drive attached to the SATA port.• Capacity: Specifies the total capacity of the hard drive. This field is undefined for removable media devices such as optical drives.
Port E	<p>Sets the drive type of the selected device. For the Embedded SATA settings in ATA mode, set this field to Auto to enable BIOS support. Set it to OFF to turn off BIOS support.</p> <p>For AHCI mode, BIOS support is always enabled.</p> <ul style="list-style-type: none">• Model: Specifies the drive model of the selected device.• Drive Type: Specifies the type of drive attached to the SATA port.• Capacity: Specifies the total capacity of the hard drive. This field is undefined for removable media devices such as optical drives.
Port F	<p>Sets the drive type of the selected device. For the Embedded SATA settings in ATA mode, set this field to Auto to enable BIOS support. Set it to OFF to turn off BIOS support.</p> <p>For AHCI mode, BIOS support is always enabled.</p> <ul style="list-style-type: none">• Model: Specifies the drive model of the selected device.• Drive Type: Specifies the type of drive attached to the SATA port.• Capacity: Specifies the total capacity of the hard drive. This field is undefined for removable media devices such as optical drives.

Table 33. SATA Settings (continued)

Option	Description
Port G	<p>Sets the drive type of the selected device. For the Embedded SATA settings in ATA mode, set this field to Auto to enable BIOS support. Set it to OFF to turn off BIOS support.</p> <p>For AHCI mode, BIOS support is always enabled.</p> <ul style="list-style-type: none"> • Model: Specifies the drive model of the selected device. • Drive Type: Specifies the type of drive attached to the SATA port. • Capacity: Specifies the total capacity of the hard drive. This field is undefined for removable media devices such as optical drives.
Port H	<p>Sets the drive type of the selected device. For the Embedded SATA settings in ATA mode, set this field to Auto to enable BIOS support. Set it to OFF to turn off BIOS support.</p> <p>For AHCI mode, BIOS support is always enabled.</p> <ul style="list-style-type: none"> • Model: Specifies the drive model of the selected device. • Drive Type: Specifies the type of drive attached to the SATA port. • Capacity: Specifies the total capacity of the hard drive. This field is undefined for removable media devices such as optical drives.
Port I	<p>Sets the drive type of the selected device. For the Embedded SATA settings in ATA mode, set this field to Auto to enable BIOS support. Set it to OFF to turn off BIOS support.</p> <p>For AHCI mode, BIOS support is always enabled.</p> <ul style="list-style-type: none"> • Model: Specifies the drive model of the selected device. • Drive Type: Specifies the type of drive attached to the SATA port. • Capacity: Specifies the total capacity of the hard drive. This field is undefined for removable media devices such as optical drives.
Port J	<p>Sets the drive type of the selected device. For the Embedded SATA settings in ATA mode, set this field to Auto to enable BIOS support. Set it to OFF to turn off BIOS support.</p> <p>For AHCI mode, BIOS support is always enabled.</p> <ul style="list-style-type: none"> • Model: Specifies the drive model of the selected device. • Drive Type: Specifies the type of drive attached to the SATA port. • Capacity: Specifies the total capacity of the hard drive. This field is undefined for removable media devices such as optical drives.

Integrated Devices

You can use the **Integrated Devices** screen to view and configure the settings of all integrated devices including the video controller, integrated RAID controller, and the USB ports.

Viewing Integrated Devices

To view the **Integrated Devices** screen, perform the following steps:

- 1 Turn on, or restart your system.
- 2 Press F2 immediately after you see the following message:
F2 = System Setup

 **NOTE:** If your operating system begins to load before you press F2, wait for the system to finish booting, and then restart your system and try again.

- 3 On the **System Setup Main Menu** screen, click **System BIOS**.
- 4 On the **System BIOS** screen, click **Integrated Devices**.

Integrated Devices details

The **Integrated Devices** screen details are explained as follows:

Table 34. Integrated Devices

Option	Description
User Accessible USB Ports	Enables or disables the USB ports. Selecting All Ports Off disables all USB ports. The USB keyboard and mouse operate during boot process in certain operating systems. After the boot process is complete, the USB keyboard and mouse do not work if the ports are disabled.  NOTE: Selecting All Ports Off disables the USB management port and also restricts access to the iDRAC features.
Internal USB Port 1	Enables or disables the internal USB port.
Internal USB Port 2	Enables or disables the internal USB port.
Internal USB Port	Enables or disables the internal USB port. This option is set to On or Off .
Embedded NIC1	Enables or disables the Embedded NIC1 port. The option is set to Enabled by default.
iDRAC Direct USB Port	Enables or disables the internal USB port. This option is set to On or Off .
I/OAT DMA Engine	Enables or disables the I/OAT option. Enable only if the hardware and software support the feature.
Embedded Video Controller	Enables or disables the Embedded Video Controller option. This option is set to Enabled by default.
Current State of Embedded Video Controller	Displays the current state of the embedded video controller. The Current State of Embedded Video Controller option is a read-only field. If the Embedded Video Controller is the only display capability in the system (that is, no add-in graphics card is installed), then the Embedded Video Controller is automatically used as the primary display even if the Embedded Video Controller setting is set to Disabled .

Table 34. Integrated Devices (continued)

Option	Description
SR-IOV Global Enable	Enables or disables the BIOS configuration of Single Root I/O Virtualization (SR-IOV) devices. This option is set to Disabled by default.
OS Watchdog Timer	If your system stops responding, this watchdog timer aids in the recovery of your operating system. When this option is set to Enabled , the operating system initializes the timer. When this option is set to Disabled (the default), the timer does not have any effect on the system.
Memory Mapped I/O above 4 GB	Enables or disables the support for the PCIe devices that need large amounts of memory. This option is set to Enabled by default.
Memory Mapped I/O above Base	Enables the memory mapped base to either 56 TB, or 12 TB, or 512 GB. The default option is set to 56 TB.
Slot Disablement	Enables or disables the available PCIe slots on your system. The slot disablement feature controls the configuration of the PCIe cards installed in the specified slot. Slots must be disabled only when the installed peripheral card prevents booting into the operating system or causes delays in system startup. If the slot is disabled, both the Option ROM and UEFI drivers are disabled. <ul style="list-style-type: none">• Slot 1: Enables or disables the PCIe slot 1. This option is set to Enabled by default• Slot 3: Enables or disables or only the boot driver is disabled for the PCIe slot 3. This option is set to Enabled by default• Slot 4: Enables or disables or only the boot driver is disabled for the PCIe slot 3. This option is set to Enabled by default• Slot 5: Enables or disables or only the boot driver is disabled for the PCIe slot 3. This option is set to Enabled by default
Slot Bifurcation	Allows Platform Manual Bifurcation Control <ul style="list-style-type: none">• Slot1/3/4/5/6: X16 or X8 or X4 or X8X4X4 or X4X4X8

Serial Communication

You can use the **Serial Communication** screen to view the properties of the serial communication port.

Viewing Serial Communication

To view the **Serial Communication** screen, perform the following steps:

- 1 Turn on, or restart your system.
- 2 Press F2 immediately after you see the following message:
F2 = System Setup



NOTE: If your operating system begins to load before you press F2, wait for the system to finish booting, and then restart your system and try again.

- 3 On the System Setup Main Menu screen, click System BIOS.
- 4 On the System BIOS screen, click Serial Communication.

Serial Communication details

The Serial Communication screen details are explained as follows:

Table 35. Serial Communication





Option	Description
Serial Communication	<p>Selects serial communication devices (Serial Device 1 and Serial Device 2) in BIOS. BIOS console redirection can also be enabled, and the port address can be specified. This option is set to Auto by default.</p> <p>Enables the COM port or Console Redirection options. This option is set to Off by default.</p> <p>Selects serial communication devices (Serial Device 1 and Serial Device 2) in BIOS. Enables the COM1 port. This option is set to On with Console Redirection via COM1 by default.</p>
Serial Port Address	<p>Enables you to set the port address for serial devices. This option is set to Serial Device1=COM1, Serial Device 2 = COM2Serial Device 1=COM2, Serial Device 2=COM1 by default.</p> <p> NOTE: You can use only Serial Device 2 for the Serial Over LAN (SOL) feature. To use console redirection by SOL, configure the same port address for console redirection and the serial device.</p> <p> NOTE: Every time the system boots, the BIOS syncs the serial MUX setting saved in iDRAC. The serial MUX setting can independently be changed in iDRAC. Loading the BIOS default settings from within the BIOS setup utility may not always revert the serial MUX setting to the default setting of Serial Device 1.</p>
External Serial Connector	<p>Enables you to associate the External Serial Connector to Serial Device 1, Serial Device 2, or the Remote Access Device by using this option.</p> <p> NOTE: Only Serial Device 2 can be used for Serial Over LAN (SOL). To use console redirection by SOL, configure the same port address for console redirection and the serial device.</p> <p> NOTE: Every time the system boots, the BIOS syncs the serial MUX setting saved in iDRAC. The serial MUX setting can independently be changed in iDRAC. Loading the BIOS default settings from within the BIOS setup utility may not always revert this setting to the default setting of Serial Device 1.</p> <p>Enables you to associate the External Serial Connector to Serial Device 1.</p>

Table 35. Serial Communication (continued)

Option	Description
Failsafe Baud Rate	Specifies the failsafe baud rate for console redirection. The BIOS attempts to determine the baud rate automatically. This failsafe baud rate is used only if the attempt fails, and the value must not be changed. This option is set to 115200 by default.
Remote Terminal Type	Sets the remote console terminal type. This option is set to ANSIVT 100/VT 220 by default.
Redirection After Boot	Enables or disables the BIOS console redirection when the operating system is loaded. This option is set to Enabled by default.

System Profile Settings

You can use the **System Profile Settings** screen to enable specific system performance settings such as power management.

Viewing System Profile Settings

To view the **System Profile Settings** screen, perform the following steps:

- 1 Turn on, or restart your system.
- 2 Press F2 immediately after you see the following message:

F2 = System Setup



NOTE: If your operating system begins to load before you press F2, wait for the system to finish booting, and then restart your system and try again.

- 3 On the **System Setup Main Menu** screen, click **System BIOS**.
- 4 On the **System BIOS** screen, click **System Profile Settings**.

System Profile Settings details

The **System Profile Settings** screen details are explained as follows:

Table 36. System Profile Settings

Option	Description
System Profile	Sets the system profile. If you set the System Profile option to a mode other than Custom , the BIOS automatically sets the rest of the options. You can only change the rest of the options if the mode is set to Custom . This option is set to Performance Per Watt Optimized (DAPC) by default. DAPC is Dell Active Power Controller., other options include Performance Per Watt (OS) , Performance Per Watt (HWPM) , Performance , and Workstation Performance .



NOTE: All the parameters on the system profile setting screen are available only when the System Profile option is set to **Custom**.

Table 36. System Profile Settings (continued)



Option	Description
CPU Power Management	Sets the CPU power management. This option is set to System DBPM (DAPC) by default. DBPM is Demand-Based Power Management. Other options include OS DBPM , Maximum Performance , and Hardware P States .
Memory Frequency	Sets the speed of the system memory. You can select Maximum Performance , Maximum Reliability , or a specific speed.
Turbo Boost	Enables or disables the processor to operate in the turbo boost mode. This option is set to Enabled by default.
Energy Efficient Turbo	Enables or disables the Energy Efficient Turbo option. Energy Efficient Turbo (EET) is a mode of operation where a processor's core frequency is adjusted to be within the turbo range based on workload.
CIE	Enables or disables the processor to switch to a minimum performance state when it is idle. This option is set to Enabled by default.
C States	Enables or disables the processor to operate in all available power states. This option is set to Enabled by default.
Write Data CRC	Enables or disables the Write Data CRC. This option is set to Enabled by default.
Collaborative CPU Performance Control	Enables or disables the CPU power management option. When set to Enabled , the CPU power management is controlled by the OS DBPM and the System DBPM (DAPC). This option is set to Disabled by default.
Memory Patrol Scrub	Sets the memory patrol scrub frequency. This option is set to Standard by default.
Memory Refresh Rate	Sets the memory refresh rate to either 1x or 2x. This option is set to 1x by default.
Uncore Frequency	Enables you to select the Processor Uncore Frequency option. Dynamic mode enables the processor to optimize power resources across the cores and uncore during runtime. The optimization of the uncore frequency to either save power or optimize performance is influenced by the setting of the Energy Efficiency Policy option.
Energy Efficient Policy	Enables you to select the Energy Efficient Policy option. The CPU uses the setting to manipulate the internal behavior of the processor and determines whether to target higher performance or better power savings.
Number of Turbo Boot Enabled Cores for Processor 1	 NOTE: If there are two processors installed in the system, you see an entry for Number of Turbo Boost Enabled Cores for Processor 2 . Controls the number of turbo boost enabled cores for processor 1. The maximum number of cores is enabled by default.

Table 36. System Profile Settings (continued)

Option	Description
Monitor/Mwait	<p>Enables the Monitor/Mwait instructions in the processor. This option is set to Enabled for all system profiles, except Custom by default.</p> <p> NOTE: This option can be disabled only if the C States option in the Custom mode is set to disabled.</p> <p> NOTE: When C States is set to Enabled in the Custom mode, changing the Monitor/Mwait setting does not impact the system power or performance.</p>
CPU Interconnect Bus Link Power Management	Enables or disables the CPU Interconnect Bus Link Power Management. This option is set to Enabled by default.
PCI ASPM L1 Link Power Management	Enables or disables the PCI ASPM L1 Link Power Management. This option is set to Enabled by default.

Miscellaneous Settings

You can use the **Miscellaneous Settings** screen to perform specific functions such as updating the asset tag and changing the system date and time.

Viewing Miscellaneous Settings

To view the **Miscellaneous Settings** screen, perform the following steps:

- 1 Turn on, or restart your system.
- 2 Press F2 immediately after you see the following message:
F2 = System Setup

 **NOTE:** If your operating system begins to load before you press F2, wait for the system to finish booting, and then restart your system and try again.

- 3 On the **System Setup Main Menu** screen, click **System BIOS**.
- 4 On the **System BIOS** screen, click **Miscellaneous Settings**.



Miscellaneous Settings details

The **Miscellaneous Settings** screen details are explained as follows:

Table 37. Miscellaneous Settings

Option	Description
System Time	Enables you to set the time on the system.
System Date	Enables you to set the date on the system.
Asset Tag	Specifies the asset tag and enables you to modify it for security and tracking purposes.

Table 37. Miscellaneous Settings (continued)

Option	Description
Keyboard NumLock	Enables you to set whether the system boots with the NumLock enabled or disabled. This option is set to On by default.  NOTE: This option does not apply to 84-key keyboards.
F1/F2 Prompt on Error	Enables or disables the F1/F2 prompt on error. This option is set to Enabled by default. The F1/F2 prompt also includes keyboard errors.
Load Legacy Video Option ROM	Enables you to determine whether the system BIOS loads the legacy video (INT 10H) option ROM from the video controller. Selecting Enabled in the operating system does not support UEFI video output standards. This field is available only for UEFI boot mode. You cannot set the option to Enabled if UEFI Secure Boot mode is enabled.
In-System Characterization	Enables or disables In-System Characterization . This option is set to Disabled by default. The two other options are Enabled and Enabled - No Reboot .  NOTE: The default setting for In-System Characterization is subject to change in future BIOS releases. When enabled, In-System Characterization (ISC) executes during POST upon detecting relevant changes in system configuration to optimize system power and performance. ISC takes about 20 seconds to execute, and system reset is needed for ISC results to be applied. The Enabled - No Reboot option executes ISC and continues without applying ISC results until the next time system reset occurs. The Enabled option executes ISC and forces an immediate system reset so that ISC results can be applied. It takes the system longer to be ready due to the forced system reset. When disabled, ISC does not execute.
Dell Wyse P25/P45 BIOS Access	Enables or disables the Dell Wyse P25/P45 BIOS Access. This option is set to Enabled by default.
Power Cycle Request	Enables or disables the Power Cycle Request. This option is set to None by default.

iDRAC Settings utility

The iDRAC settings utility is an interface to set up and configure the iDRAC parameters by using UEFI. You can enable or disable various iDRAC parameters by using the iDRAC settings utility.

 **NOTE:** Accessing some of the features on the iDRAC settings utility needs the iDRAC Enterprise License upgrade. For more information about using iDRAC, see Dell Integrated Dell Remote Access Controller User's Guide at Dell.com/idracmanuals.

Entering the iDRAC Settings utility

- 1 Turn on or restart the managed system.

- 2 Press F2 during Power-on Self-test (POST).
- 3 On the **System Setup Main Menu** page, click **iDRAC Settings**.
The **iDRAC Settings** screen is displayed.

Changing thermal settings

The iDRAC settings utility enables you to select and customize the thermal control settings for your system.



NOTE: Selection of thermal profile does not change the default Fan speed. Fan speed automatically changes as per the system temperature irrespective of the THERMAL PROFILE in effect or select the Custom fan speed option to set it to desired speed.

- 1 Click **iDRAC Settings > Thermal**.
- 2 Under **SYSTEM THERMAL PROFILE > Thermal Profile**, select one of the following options:
 - Default Thermal Profile Settings
 - Maximum Performance (Optimized)
 - Minimum Power (Performance per Watt Optimized)
- 3 Under **USER COOLING OPTIONS**, set the **Fan Speed Offset**, **Minimum Fan Speed**, and **Custom Minimum Fan Speed**.
- 4 Click **Back > Finish > Yes**.

Device Settings

Device Settings enables you to configure device parameters.

Dell Lifecycle Controller

Dell Lifecycle Controller (LC) provides advanced embedded systems management capabilities including system deployment, configuration, update, maintenance, and diagnosis. LC is delivered as part of the iDRAC out-of-band solution and Dell system embedded Unified Extensible Firmware Interface (UEFI) applications.

Embedded system management

The Dell Lifecycle Controller provides advanced embedded system management throughout the system's lifecycle. The Dell Lifecycle Controller can be started during the boot sequence and can function independently of the operating system.



NOTE: Certain platform configurations may not support the full set of features provided by the Dell Lifecycle Controller.

For more information about setting up the Dell Lifecycle Controller, configuring hardware and firmware, and deploying the operating system, see the Dell Lifecycle Controller documentation at Dell.com/idracmanuals.

Boot Manager

The **Boot Manager** screen enables you to select boot options and diagnostic utilities.

Viewing Boot Manager

About this task

To enter Boot Manager:

Steps

- 1 Turn on, or restart your system.
Enter the result of your step here (optional).
- 2 Press F11 when you see the following message:

F11 = Boot Manager

If your operating system begins to load before you press F11, allow the system to complete the booting, and then restart your system and try again.

Boot Manager main menu

Table 38. Boot Manager main menu

Menu item	Description
Continue Normal Boot	The system attempts to boot to devices starting with the first item in the boot order. If the boot attempt fails, the system continues with the next item in the boot order until the boot is successful or no more boot options are found.
One-shot Boot Menu	Enables you to access boot menu, where you can select a one-time boot device to boot from.
Launch System Setup	Enables you to access System Setup.
Launch Lifecycle Controller	Exits the Boot Manager and invokes the Dell Lifecycle Controller program.
System Utilities	Enables you to launch System Utilities menu such as System Diagnostics and UEFI shell.

One-shot BIOS boot menu

One-shot BIOS boot menu enables you to select a boot device to boot from.

System Utilities

System Utilities contains the following utilities that can be launched:

- Launch Diagnostics
- BIOS Update File Explorer
- Reboot System

PXE boot







You can use the Preboot Execution Environment (PXE) option to boot and configure the networked systems, remotely.



NOTE: To access the PXE boot option, boot the system and then press F12. The system scans and displays the active networked systems.

Installing and removing server components

Safety instructions

-  **WARNING:** Whenever you need to lift the system, get others to assist you. To avoid injury, do not attempt to lift the system by yourself.
-  **WARNING:** Opening or removing the system cover while the system is powered on may expose you to a risk of electric shock.
-  **CAUTION:** Do not operate the system without the cover for a duration exceeding five minutes.
-  **CAUTION:** Many repairs may only be done by a certified service technician. You should only perform troubleshooting and simple repairs as authorized in your product documentation, or as directed by the online or telephone service and support team. Damage due to servicing that is not authorized by Dell is not covered by your warranty. Read and follow the safety instructions that are shipped with your product.
-  **CAUTION:** Operating the system without the system cover can result in component damage.
-  **NOTE:** Dell recommends that you always use a static mat and static strap while working on components inside the system.
-  **NOTE:** To ensure proper operation and cooling, all bays in the system and system fans must be populated always with a component or with a blank.

Before working inside your system

Prerequisites

Follow the safety guidelines listed in Safety instructions.

Step

- 1 Turn off the server, including any attached peripherals.
- 2 Disconnect the system from the electrical outlet and disconnect the peripherals.
- 3 If applicable, remove the system from the rack.

For more information, see the Rack Installation placemat at Dell.com/dssmanuals.

After working inside your system

Prerequisites

Follow the safety guidelines listed in Safety instructions.

Step

- 1 If applicable, install the system into the rack.
For more information, see the Rack Installation placemat at Dell.com/dssmanuals.
- 2 Reconnect the peripherals and connect the system to the electrical outlet.
- 3 Turn on the system, including any attached peripherals.

Recommended tools

You need the following tools to perform the removal and installation procedures:

- Key to the bezel lock
The key is needed only if your system includes a bezel.
- Phillips #1 screwdriver
- Phillips #2 screwdriver
- 1/4 inch flat head screwdriver
- Torx #T20 screwdriver
- Torx #T30 screwdriver
- Torx #T6, #T8, #T10, and #T15 screwdrivers
- Wrist grounding strap

You need the following tools to assemble the cables for a DC power supply unit.

- AMP 90871-1 hand-crimping tool or equivalent
- Tyco Electronics 58433-3 or equivalent
- Wire-stripper pliers to remove insulation from size 10 AWG solid or stranded, insulated copper wire



NOTE: Use alpha wire part number 3080 or equivalent (65/30 stranding).

System memory

This section provides information on memory population rules, general requirements and instructions on removing and installing memory modules.

General memory module installation guidelines

 **NOTE:** Memory configurations that fail to observe these guidelines can prevent your system from booting, stop responding during memory configuration, or operating with reduced memory.

The system supports Flexible Memory Configuration, enabling the system to be configured and run in any valid chipset architectural configuration. The following are the recommended guidelines for installing memory modules:

- RDIMMs and LRDIMMs must not be mixed.
- x4 and x8 DRAM based memory modules can be mixed. For more information, see the Mode-specific guidelines section.
- Both dual-rank and single-rank RDIMMs can be populated in each channel.
- Up to two LRDIMMs can be populated per channel regardless of rank count.
- If memory modules with different speeds are installed, they will operate at the speed of the slowest installed memory module(s) or slower depending on system DIMM configuration.
- Populate memory module sockets only if a processor is installed. For single-processor systems, sockets A1 to A8 are available. For dual-processor systems, sockets A1 to A8 and sockets B1 to B8 are available.
- Populate all the sockets with white release tabs first, followed by the black release tabs.
- When mixing memory modules with different capacities, populate the sockets with memory modules with highest capacity first. For example, if you want to mix 4 GB and 8 GB memory modules, populate 8 GB memory modules in the sockets with white release tabs and 4 GB memory modules in the sockets with black release tabs.
- In a dual-processor configuration, the memory configuration for each processor should be identical. For example, if you populate socket A1 for processor 1, then populate socket B1 for processor 2, and so on.
- Memory modules of different capacities can be mixed provided other memory population rules are followed (for example, 4 GB and 8 GB memory modules can be mixed).
- Mixing of more than two memory module capacities in a system is not supported.
- Populate six memory modules per processor (one DIMM per channel) at a time to maximize performance.

Related Links

[Mode-specific guidelines](#)

Mode-specific guidelines

Six memory channels are allocated to each processor. The allowable configurations depend on the memory mode selected.

Memory optimized (independent channel) mode

This mode supports Single Device Data Correction (SDDC) only for memory modules that use x4 device width. It does not impose any specific slot population requirements.

Memory sparing

 **NOTE:** To use memory sparing, this feature must be enabled in System Setup.

In this mode, one rank per channel is reserved as a spare. If persistent correctable errors are detected on a rank, the data from this rank is copied to the spare rank, and the failed rank is disabled.

With memory sparing enabled, the system memory available to the operating system is reduced by one rank per channel. For example, in a dual-processor configuration with sixteen 4 GB single-rank memory modules, the available system memory is: $\frac{3}{4}$ (ranks/channel) \times 16 (memory modules) \times 4 GB = 48 GB, and not 16 (memory modules) \times 4 GB = 64 GB.

 **NOTE:** Memory sparing does not offer protection against a multi-bit uncorrectable error.

 **NOTE:** Both Advanced ECC/Lockstep and Optimizer modes support memory sparing.

Memory mirroring

Memory mirroring offers the strongest memory module reliability mode compared to all other modes, providing improved uncorrectable multi-bit failure protection. In a mirrored configuration, the total available system memory is one half of the total installed physical memory. Half of the installed memory is used to mirror the active memory modules. In the event of an uncorrectable error, the system switches over to the mirrored copy. This ensures SDDC and multi-bit protection.

The installation guidelines for memory modules are as follows:

- Memory modules must be identical in size, speed, and technology.
- Memory modules installed in memory module sockets with white release levers must be identical and the same rule applies for sockets with black release tabs. This ensures that identical memory modules are installed in matched pairs—for example, A1 with A2, A3 with A4, A5 with A6, and so on.

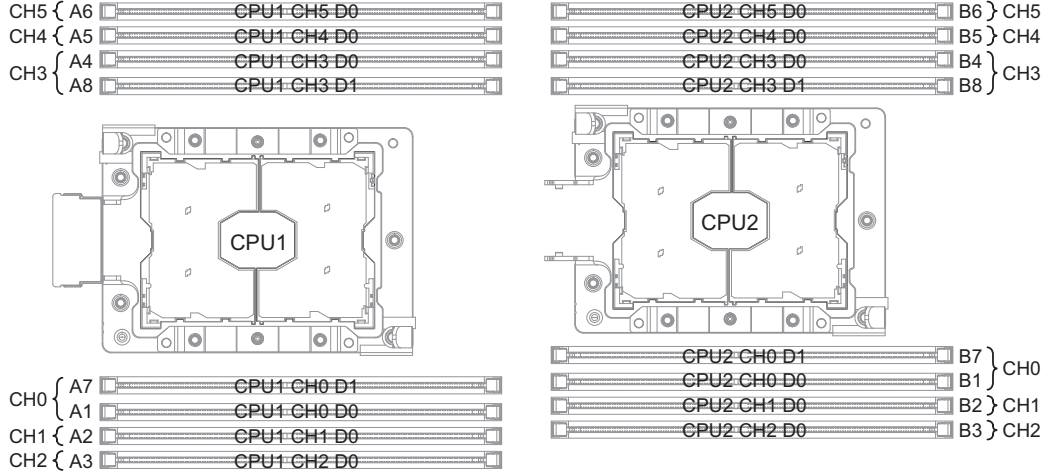

Figure 6. Memory slot locations

Table 39. Memory configuration specifications

Processor	Number of DIMMS	
	Maximum system capacity	Reliability, availability, and serviceability (RAS) features
Dual processor	16	16
Single processor	8	8

Sample memory configurations

The following tables show sample memory configurations for two and four processor configurations that follow the appropriate memory guidelines.

NOTE: 1R, 2R, 4R, and 8R in the following tables indicate single, dual, quad, and octal rank DIMMs.

Table 40. DIMM configuration specifications

DIMM type	RDIMM	LRDIMM	3DS LRDIMM	NVDIMM
RDIMM	○	×	×	○
LRDIMM	×	○	×	○
3DS LRDIMM	×	×	○	○
NVDIMM	○	○	○	×

Table 41. DIMM minimum population requirements

DIMM type	CH0		CH1	CH2	CH3	CH4		CH5
	D0 (A1)	D1 (A7)	D0 (A2)	D0 (A3)	D0 (A4)	D1 (A8)	D0 (A5)	D0 (A6)
1LM DDR4	DRE	DO	DRE	DRE	DO	DO	DO	DO
1LM DDR4	DR	NR	DO	DO	DR	NR	DO	DO

- DR: DDR4 required.
- DRE: DDR4 required. But plugging in either one slot is allowed. Then the other 2 slots become DDR4 optional.
- DO: DDR4 optional.
- NR: NVDIMM required.
- NO: NVDIMM optional.

Removing memory module

Prerequisites

 **CAUTION:** Many repairs may only be done by a certified service technician. You should only perform troubleshooting and simple repairs as authorized in your product documentation, or as directed by the online or telephone service and support team. Damage due to servicing that is not authorized by Dell is not covered by your warranty. Read and follow the safety instructions that are shipped with your product.

- 1 Ensure that you read the Safety instructions.
- 2 Complete the procedure listed in Before working inside your system.

 **WARNING:** The memory modules are hot to touch for some time after the system has been powered down. Allow the memory modules to cool before handling them. Handle the memory modules by the card edges and avoid touching the components or metallic contacts on the memory module.

 **CAUTION:** To ensure proper system cooling, memory module blanks must be installed in any memory socket that is not occupied. Remove memory module blanks only if you intend to install memory modules in those sockets.

Steps

- 1 Pull the air baffle tab to release it from the underneath the DIMM socket lever.
- 2 Remove the air baffle.

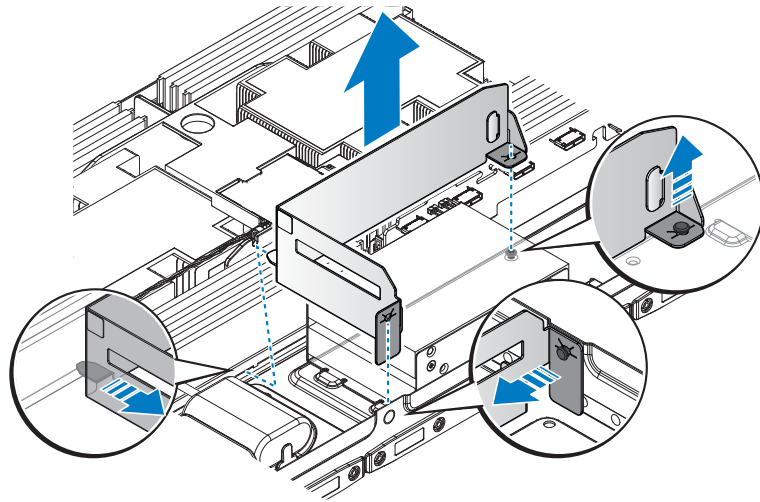

Figure 7. Removing the air baffle

- 3 Locate the appropriate memory module.

⚠ CAUTION: Handle each memory module by the card edges, ensuring not to touch the middle of the memory module or metallic contacts.

- 4 Press down on the two memory module locking latches. The memory module partially ejects.
- 5 Lift the memory module.

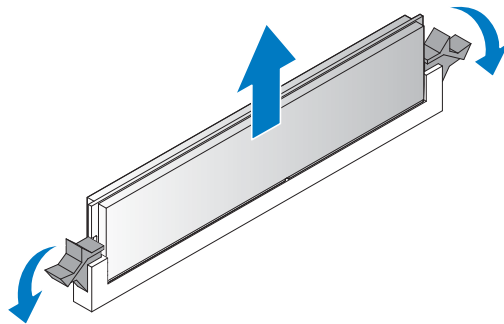

Figure 8. Removing the memory module

Next steps

- 1 Install the new memory module.
- 2 Complete the procedure listed in After working inside your system.

Related Links

- [Installing memory module](#)

Installing memory module

Prerequisites

- 1 Ensure that you read the Safety instructions.
- 2 Complete the procedure listed in [Before working inside your system](#).



WARNING: Allow the memory modules to cool after you power off the system. Handle the memory modules by the card edges and avoid touching the components or metallic contacts on the memory module.



CAUTION: To ensure proper system cooling, memory module blanks must be installed in any memory socket that is not occupied. Remove memory module blanks only if you intend to install memory modules in those sockets.

Steps



CAUTION: To avoid damage, handle memory modules by the edges at all times.

- 1 Align the indentation on the memory module with the protrusion on the DIMM slot. Make sure they are aligned to avoid damaging the socket or the module.
- 2 Push the memory module firmly into the memory module slot.



NOTE: If you are removing the memory module permanently, install a memory module blank.

The locking latches should automatically close over the edges of the memory module when fully inserted into the slot.

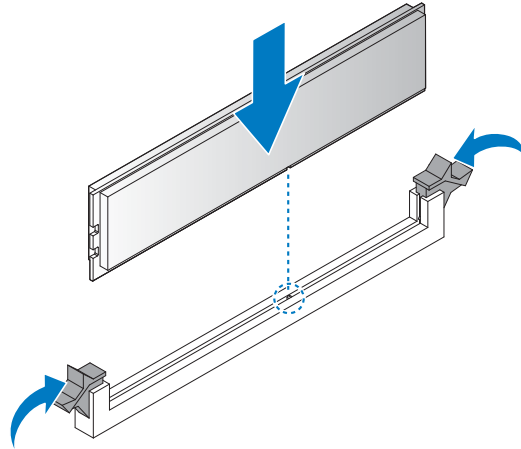

Figure 9. Installing the memory module

- 3 Fold the air baffle.

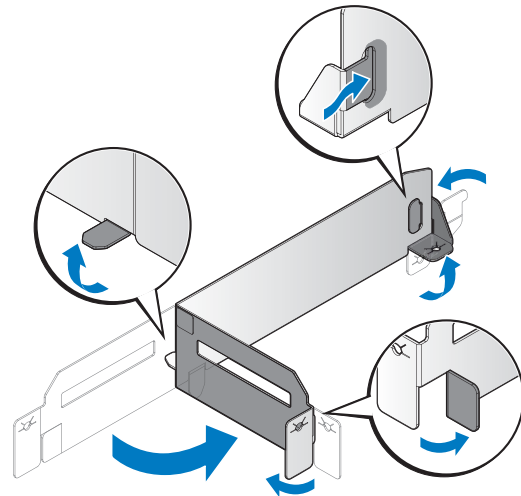

Figure 10. Folding the air baffle

- 4 Align the air baffle with the DIMM sockets, the end tabs runs between the DIMM locking latches.
- 5 Press the air baffle tabs down to lock on the standoffs on the chassis.

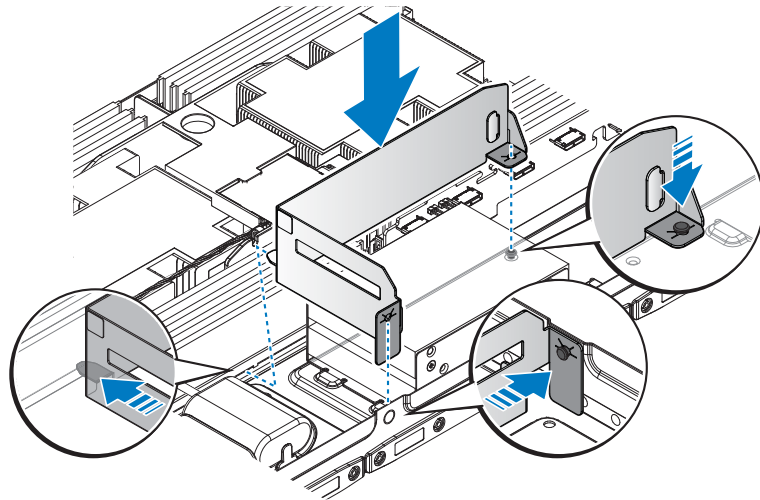

Figure 11. Installing the air baffle

Next steps

- 1 Complete the procedure listed in *After working inside your system*.
- 2 Press F2 to start System Setup, and check the System Memory setting.
The **System Memory** value should reflect the newly installed memory.

If the value is incorrect, one or more of the memory modules may not be installed properly. Repeat Step 2 and Step 3 of this procedure, checking to ensure that the memory modules are firmly seated in their sockets.

- 3 Run the system memory test in the system diagnostics.

Processor and heat sink

Use the following procedure when:

- Removing and installing the heat sink
- Installing the additional processor
- Replacing the processor

 **NOTE:** To ensure proper system cooling, you must install a processor blank in any empty processor socket.

Removing heat sink

Prerequisites

CAUTION: Never remove the heat sink from a processor unless you intend to remove the processor. The heat sink is necessary to maintain proper thermal conditions.

WARNING: The heat sink is hot to touch. Allow the heat sink to cool for some time after powering down the system.

- 1 Ensure that you read the Safety instructions.
- 2 Keep the #2 Phillips screwdriver handy.
- 3 Follow the procedure listed in the Before working inside your system section.
- 4 Before upgrading your system, download the latest system BIOS version from dell.com/support and follow the instructions included in the compressed download file to install the update on your system.

NOTE: You can update the system BIOS using the Lifecycle Controller. For more information about Dell Lifecycle controller, see dell.com/idracmanuals.

- 5 Complete the procedure listed in Before working inside your system.

Steps

- 1 Disconnect the cable from the Mini PERC.
- 2 Remove the air shroud located between the heat sinks.

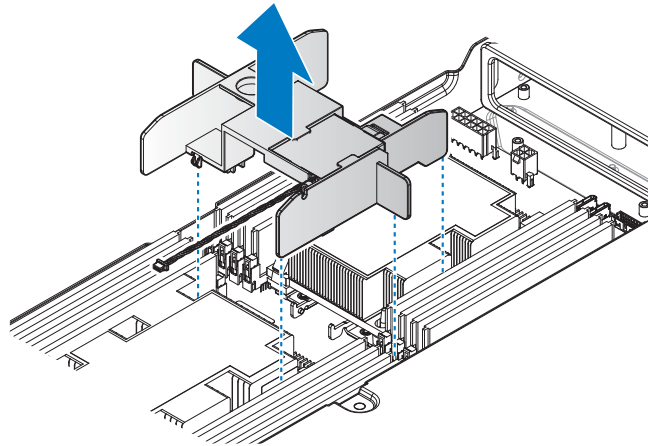

Figure 12. Removing the air shroud

- 3 In a sequential order, loosen the four screws securing the processor assembly.
- 4 Push the release latches to unlock the heat sink.
- 5 Remove the processor assembly and heat sink.

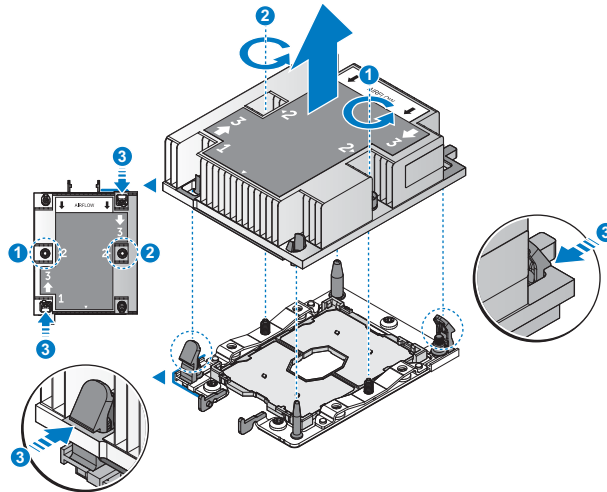

Figure 13. Removing the heat sink

Next steps

- 1 Separate the heat sink and the processor.
- 2 Remove the processor.
- 3 Complete the procedure listed in After working inside your system.

Related Links

- Removing processor

Removing processor

 **NOTE:** If the new heat sink includes a thermal pad, it is not necessary to apply thermal grease to the top of the processor.

Prerequisites

- 1 Ensure that you read the Safety instructions.
- 2 Before upgrading your system, download the latest system BIOS version from dell.com/support and follow the instructions included in the compressed download file to install the update on your system.

 **NOTE:** You can update the system BIOS using the Lifecycle Controller. For more information about Dell Lifecycle controller, see dell.com/idracmanuals.

- 3 Complete the procedure listed in Before working inside your system.
- 4 Remove the heat sink.

Steps

- 1 Press the locking latches on all sides of the assembly and lift the heat sink out.
- 2 Remove the heat sink to expose the carrier and processor.

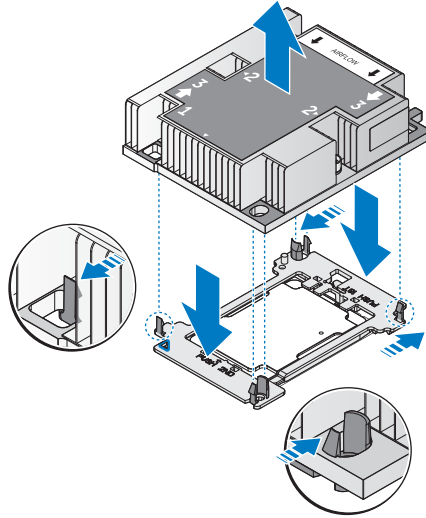

Figure 14. Separating the processor and heat sink

- 3 Release the latches to unlock the processor from the carrier. Allow some time (approximately 30 seconds) for the heat sink to loosen from the processor.
- 4 Remove the processor.

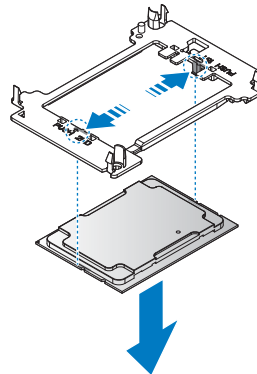

Figure 15. Separating the processor and carrier

Next steps

- 1 Install the new processor.

- 2 Complete the procedure listed in After working inside your system.

Related Links

- Removing heat sink
- Installing processor

Installing processor

Prerequisites

- 1 Ensure that you read the Safety instructions.
- 2 Before upgrading your system, download the latest system BIOS version from dell.com/support and follow the instructions included in the compressed download file to install the update on your system.

 **NOTE:** You can update the system BIOS using the Dell Lifecycle Controller.

- 3 Complete the procedure listed in Before working inside your system.

Steps

- 1 Align the processor on the processor tray.

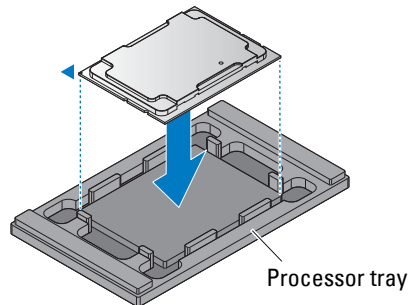

Figure 16. Aligning the processor on the processor tray

- 2 Align the triangular cutout of the socket and the indent on processor carrier with the gold triangle identifying pin of the processor.
- 3 Press the processor carrier to make sure the processor carrier is locked on the processor.

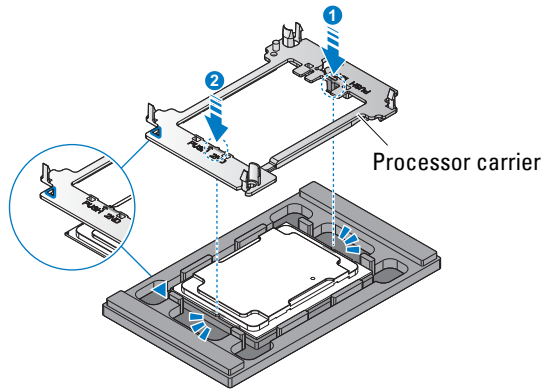

Figure 17. Installing the processor carrier

Next steps

- 1 Install the heat sink.
- 2 Complete the procedure listed in After working inside your system.

Related Links

- Installing heat sink

Installing heat sink

Prerequisites

- 1 Ensure that you read the Safety instructions.
- 2 Keep the #2 Phillips screwdriver handy.
- 3 Before upgrading your system, download the latest system BIOS version from dell.com/support and follow the instructions included in the compressed download file to install the update on your system.



NOTE: You can update the system BIOS using the Dell Lifecycle Controller.

- 4 Complete the procedure listed in Before working inside your system.
- 5 Install the processor.

Steps

- 1 Remove the TIM protective film from the heat sink.

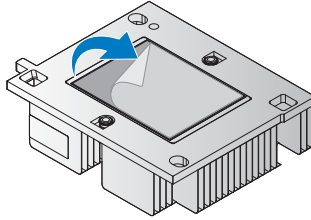

Figure 18. Removing the TIM protective film

- 2 Align the marked corner on the heat sink with the correlating location on the processor carrier.
- 3 Press the heat sink to lock it on the processor carrier.

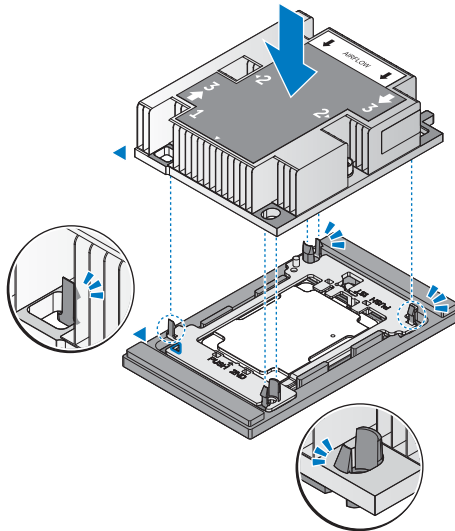

Figure 19. Inserting the heat sink in a processor tray assembly

- 4 Once the heat sink locks onto the carrier, remove the heat sink and processor assembly from the processor tray.

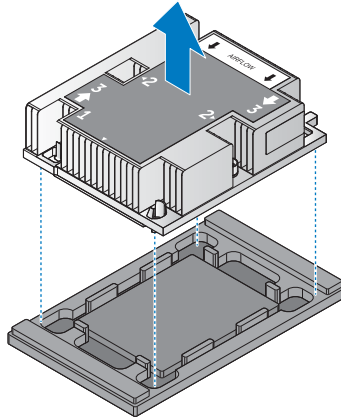

Figure 20. Removing the processor assembly from the processor tray

- 5 Align the processor assembly on the server board, until it is seated firmly in place.
- 6 In the marked order, tighten the retaining screws to secure the processor assembly.

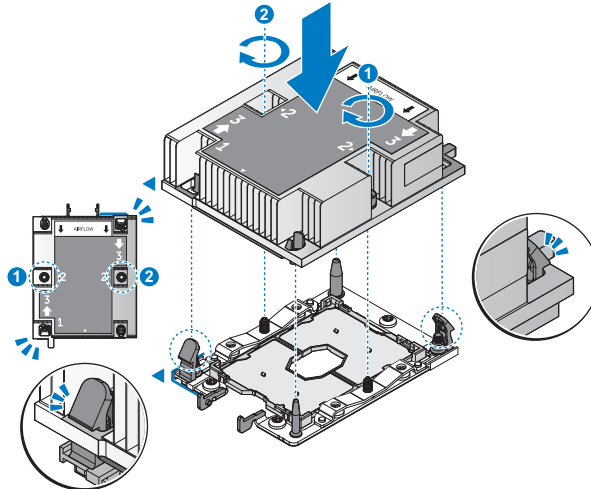

Figure 21. Installing the processor assembly

Table 42. Assembly material

Description	Quantity	Torque (lbs/inch)
CPU HSK screw	2	12 ± 0.2

- 7 Install the air shroud between the heat sinks. Make sure the air shroud is locked in place.

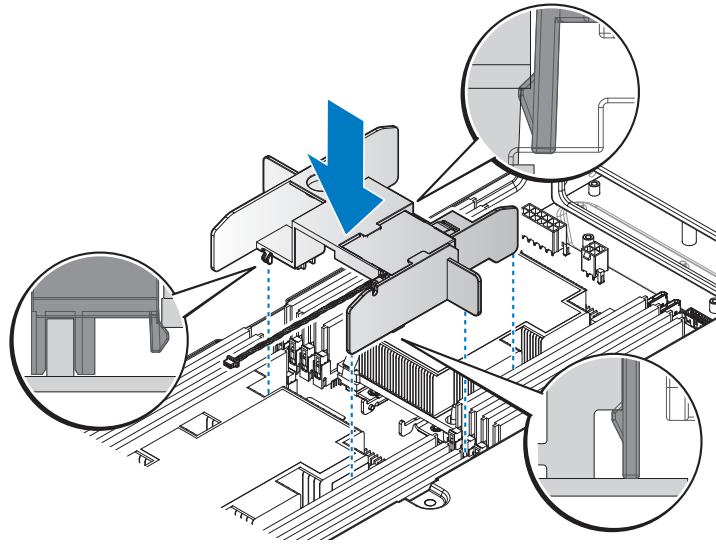

Figure 22. Installing the air shroud

Next steps

- 1 Complete the procedure listed in After working inside your system.
- 2 While booting, press F2 to start the System Setup and ensure that the processor information matches the new system configuration.
- 3 Run the system diagnostics to verify that the new processor operates correctly.

Related Links

- [Installing processor](#)

Expansion card and riser

An expansion card in the server is an add-on card that can be inserted into an expansion slot on the server board or riser card to add enhanced functionality to the system through the expansion bus.



NOTE: A System Event Log (SEL) event is logged if an expansion card riser is unsupported or missing. It does not prevent your system from turning on and no BIOS POST message or F1/F2 pause is displayed.

Expansion card installation guidelines

Depending on your system configuration, the following PCI Express (PCIe) generation 3 expansion cards are supported:

Table 43. Expansion card guidelines

Slot	Expansion card type	Riser	Processor connection	Link width	Slot width
1	DCS Mezz Card	DCS Mezz Riser	Processor 1	x8	x8
	Mini PERC Card	Mini PERC Riser			
	OCP Mezz Card	Transfer Board+Bridge Board			
	x8 PCIe/SATA M.2 Card	x8 PCIe/SATA M.2 Riser			
3	OCP Mezz Card	NA	Processor 1	x8	x8
4	PCIe RAID, PCIe NIC	PCIe Riser	Processor 1	x16	x16
5	x16 PCIe/SATA M.2 Card, NVMe Card	3M Cable Riser	Processor 2	x16	x16
6	NPIO, PCIe RAID	NPIO Cable Rear Riser	Processor 2	x16	x16

 **NOTE:** To use an expansion card on slots 5 and 6, processor 2 must be installed.

 **NOTE:** Expansion cards are not hot-swappable.

Removing expansion card from slot 1

Prerequisites

 **CAUTION:** Many repairs may only be done by a certified service technician. You should only perform troubleshooting and simple repairs as authorized in your product documentation, or as directed by the online or telephone service and support team. Damage due to servicing that is not authorized by Dell is not covered by your warranty. Read and follow the safety instructions that are shipped with your product.

- 1 Follow the safety guidelines listed in the Safety instructions section.
- 2 Follow the procedure listed in the Before working inside your system section.

Related Links

- Removing mezzanine card
- Removing Mini PERC
- Removing OCP card from slot 1
- Removing x8 PCIe M.2 card
- Removing x8 SATA M.2 card

 **NOTE:** To ensure proper system cooling, the riser blank must be installed in the appropriate riser slot. Remove the riser blank only if you are installing a riser.

Installing expansion card into slot 1

 **CAUTION:** Many repairs may only be done by a certified service technician. You should only perform troubleshooting and simple repairs as authorized in your product documentation, or as directed by the online or telephone service and support team. Damage due to servicing that is not authorized by Dell is not covered by your warranty. Read and follow the safety instructions that are shipped with your product.

- 1 Follow the safety guidelines listed in the Safety instructions section.
- 2 Follow the procedure listed in the Before working inside your system section.

Related Links

- Installing mezzanine card
- Installing Mini PERC
- Installing OCP card into slot 1
- Installing x8 PCIe M.2 card
- Installing x8 SATA M.2 card

Removing expansion card from slot 3

Prerequisites

 **CAUTION:** Many repairs may only be done by a certified service technician. You should only perform troubleshooting and simple repairs as authorized in your product documentation, or as directed by the online or telephone service and support team. Damage due to servicing that is not authorized by Dell is not covered by your warranty. Read and follow the safety instructions that are shipped with your product.

- 1 Follow the safety guidelines listed in the Safety instructions section.
- 2 Follow the procedure listed in the Before working inside your system section.
- 3 Remove the expansion card from slot 1.

Related Links

- Removing expansion card from slot 1
- Removing OCP card from slot 3

 **NOTE:** To ensure proper system cooling, the riser blank must be installed in the appropriate riser slot. Remove the riser blank only if you are installing a riser.

Installing expansion card into slot 3

 **CAUTION:** Many repairs may only be done by a certified service technician. You should only perform troubleshooting and simple repairs as authorized in your product documentation, or as directed by the online or telephone service and support team. Damage due to servicing that is not authorized by Dell is not covered by your warranty. Read and follow the safety instructions that are shipped with your product.

- 1 Follow the safety guidelines listed in the Safety instructions section.
- 2 Follow the procedure listed in the Before working inside your system section.

Related Links

- [Installing OCP card into slot 3](#)

Removing expansion card from slot 4

Prerequisites

 **CAUTION:** Many repairs may only be done by a certified service technician. You should only perform troubleshooting and simple repairs as authorized in your product documentation, or as directed by the online or telephone service and support team. Damage due to servicing that is not authorized by Dell is not covered by your warranty. Read and follow the safety instructions that are shipped with your product.

- 1 Follow the safety guidelines listed in the Safety instructions section.
- 2 Follow the procedure listed in the Before working inside your system section.

Related Links

- [Removing PCIe card](#)



NOTE: To ensure proper system cooling, the riser blank must be installed in the appropriate riser slot. Remove the riser blank only if you are installing a riser.

Installing expansion card into slot 4

 **CAUTION:** Many repairs may only be done by a certified service technician. You should only perform troubleshooting and simple repairs as authorized in your product documentation, or as directed by the online or telephone service and support team. Damage due to servicing that is not authorized by Dell is not covered by your warranty. Read and follow the safety instructions that are shipped with your product.

- 1 Follow the safety guidelines listed in the Safety instructions section.
- 2 Follow the procedure listed in the Before working inside your system section.

Related Links

- [Installing PCIe card](#)

Removing expansion card from slot 5

Prerequisites

 **CAUTION:** Many repairs may only be done by a certified service technician. You should only perform troubleshooting and simple repairs as authorized in your product documentation, or as directed by the online or telephone service and support team. Damage due to servicing that is not authorized by Dell is not covered by your warranty. Read and follow the safety instructions that are shipped with your product.

- 1 Follow the safety guidelines listed in the Safety instructions section.
- 2 Follow the procedure listed in the Before working inside your system section.

Related Links

- Removing x16 PCIe M.2 card
- Removing x16 SATA M.2 card
- Removing 3M riser card
- Removing NVMe riser



NOTE: To ensure proper system cooling, the riser blank must be installed in the appropriate riser slot. Remove the riser blank only if you are installing a riser.

Installing expansion card into slot 5



CAUTION: Many repairs may only be done by a certified service technician. You should only perform troubleshooting and simple repairs as authorized in your product documentation, or as directed by the online or telephone service and support team. Damage due to servicing that is not authorized by Dell is not covered by your warranty. Read and follow the safety instructions that are shipped with your product.

- 1 Follow the safety guidelines listed in the Safety instructions section.
- 2 Follow the procedure listed in the Before working inside your system section.

Related Links

- Installing x16 PCIe M.2 card
- Installing x16 SATA M.2 card
- Installing 3M riser card
- Installing NVMe riser

Removing expansion card from slot 6

Prerequisites



CAUTION: Many repairs may only be done by a certified service technician. You should only perform troubleshooting and simple repairs as authorized in your product documentation, or as directed by the online or telephone service and support team. Damage due to servicing that is not authorized by Dell is not covered by your warranty. Read and follow the safety instructions that are shipped with your product.

- 1 Follow the safety guidelines listed in the Safety instructions section.
- 2 Follow the procedure listed in the Before working inside your system section.

Related Links

- Removing NPIO card from the rear bay
- Removing NPIO card from hot swappable bay

 **NOTE:** To ensure proper system cooling, the riser blank must be installed in the appropriate riser slot. Remove the riser blank only if you are installing a riser.

Installing expansion card into slot 6

 **CAUTION:** Many repairs may only be done by a certified service technician. You should only perform troubleshooting and simple repairs as authorized in your product documentation, or as directed by the online or telephone service and support team. Damage due to servicing that is not authorized by Dell is not covered by your warranty. Read and follow the safety instructions that are shipped with your product.

- 1 Follow the safety guidelines listed in the Safety instructions section.
- 2 Follow the procedure listed in the Before working inside your system section.

Related Links

- Installing NPIO card in the rear bay
- Installing NPIO card in hot swappable bay

System battery

The system battery is used for system functions like powering the real-time clock and storing the computer's BIOS settings.

Removing system battery

Prerequisites

 **WARNING:** There is a danger of a new battery exploding if it is incorrectly installed. Replace the battery only with the same or equivalent type recommended by the manufacturer. See your safety information for additional details.

 **CAUTION:** Many repairs may only be done by a certified service technician. You should only perform troubleshooting and simple repairs as authorized in your product documentation, or as directed by the online or telephone service and support team. Damage due to servicing that is not authorized by Dell is not covered by your warranty. Read and follow the safety instructions that came with the product.

 **NOTE:** Battery is a Field Replaceable Unit (FRU). Only Dell certified service technicians must remove or install system battery.

- 1 Follow the safety guidelines listed in the Safety instructions section.
- 2 Complete the procedure listed in Before working inside your system.
- 3 Remove the PCIe card.

Steps

- 1 Locate the battery socket, see Jumpers and connectors.

CAUTION: To avoid damage to the battery connector, you must firmly support the connector while installing or removing a battery.

- 2 To eject the battery, press firmly on the edge of the positive side of the battery in the direction of the arrow as shown in the figure.

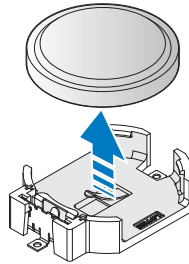

Figure 23. Removing the system battery

Next steps

- 1 Install the PCIe card.
- 2 Complete the procedure listed in After working inside your system.
- 3 While booting, press F2 to start the System Setup and ensure the battery is operating properly.
- 4 Enter the correct time and date in the System Setup Time and Date fields.
- 5 Exit the System Setup.

Related Links

- [Removing PCIe card](#)
- [Installing PCIe card](#)

Installing system battery

Prerequisites

WARNING: There is a danger of a new battery exploding if it is incorrectly installed. Replace the battery only with the same or equivalent type recommended by the manufacturer. See your safety information for additional details.

CAUTION: Many repairs may only be done by a certified service technician. You should only perform troubleshooting and simple repairs as authorized in your product documentation, or as directed by the online or telephone service and support team. Damage due to servicing that is not authorized by Dell is not covered by your warranty. Read and follow the safety instructions that came with the product.

NOTE: Battery is a Field Replaceable Unit (FRU). Only Dell certified service technicians must remove or install system battery.

- 1 Ensure that you read the Safety instructions.
- 2 Complete the procedure listed in Before working inside your system.
- 3 Remove the PCIe card.

Steps

- 1 To install a new server battery, hold the battery with the positive facing up and slide it under the securing tabs.
- 2 Press the battery into the connector until it snaps into place.

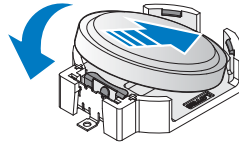

Figure 24. Installing the system battery

Next steps

- 1 Install the PCIe card.
- 2 Complete the procedure listed in After working inside your system.
- 3 While booting, press F2 to start the System Setup and ensure the battery is operating properly.
- 4 Enter the correct time and date in the System Setup **Time** and **Date** fields.
- 5 Exit the System Setup.

Related Links

- [Removing PCIe card](#)
- [Installing PCIe card](#)

Hot swappable HDD cages

Installing hot swappable HDD cage

Prerequisites

- 1 Ensure that you read the Safety instructions.
- 2 Complete the procedure listed in Before working inside your system.

Steps

- 1 Remove the securing screws from the dummy bracket.
- 2 Remove the dummy bracket.

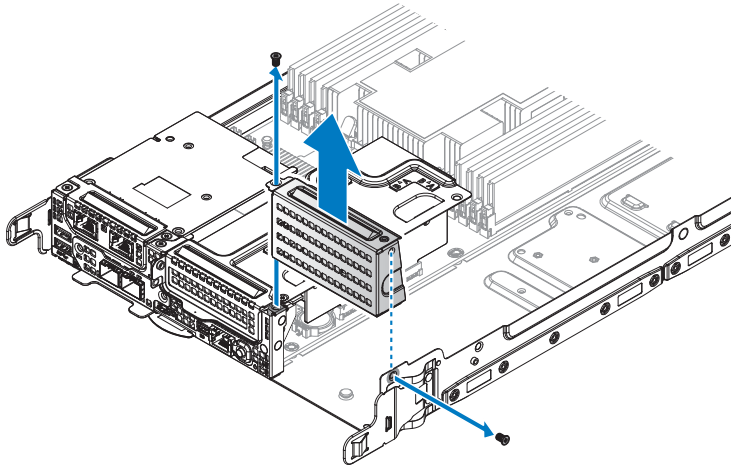

Figure 25. Removing the dummy bracket

- 3 Align the keyholes on the hot swappable HDD cage with the standoffs on the chassis.
- 4 Slide the HDD cage to lock in place.
- 5 Secure the HDD cage with the provided screws.

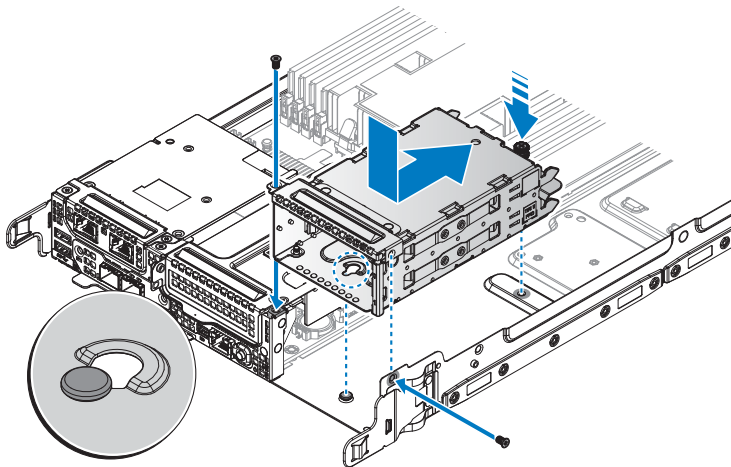

Figure 26. Installing the hot swappable HDD cage

Table 44. Assembly material

Description	Quantity	Torque (lbs/inch)
#6-32 screw	2	6 ± 0.2

Next steps

- 1 Complete the procedure listed in After working inside your system.

Removing hot swappable HDD cage

Prerequisites

- 1 Ensure that you read the Safety instructions.
- 2 Complete the procedure listed in Before working inside your system.
- 3 Remove the 2.5-inch hot swappable HDDs.
- 4 Remove the HDD backplane.

Steps

- 1 Remove the securing screws from the HDD cage.
- 2 Pull up the plunger and slide the HDD cage to release from the chassis.
- 3 Remove the HDD cage from the chassis.

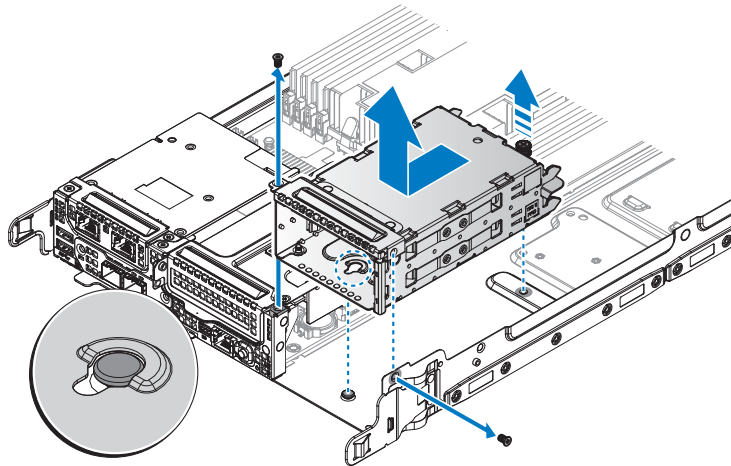

Figure 27. Removing the hot swappable HDD cage

Next steps

- 1 Install the hot swappable HDD cage.

- 2 Install the HDD backplane.
- 3 Install the 2.5-inch hot swappable HDDs.
- 4 Complete the procedure listed in After working inside your system.

Related Links

- Removing hot swappable hard drive
- Installing hot swappable HDD cage
- Installing hot swappable hard drive

Hard drive

For more information on hard drives, see the 512e and 4Kn Disk Formats white paper and 4K Sector HDD FAQ document at Dell.com/dssmanuals.

All hard drives are connected to the server board through the hard drive backplane. Hard drives are supplied in hot swappable hard drive carriers that fit in the hard drive slots.

 **CAUTION:** Before attempting to remove or install a hard drive while the system is running, see the documentation for the storage controller card to ensure that the host adapter is configured correctly to support hot swappable hard drive removal and insertion.

 **CAUTION:** Do not turn off or restart your system while the hard drive is being formatted. Doing so can cause a hard drive failure.

Use only hard drives that have been tested and approved for use with the hard drive backplane.

When you format a hard drive, allow enough time for the formatting to be complete. Be aware that high-capacity hard drives can take a long time to format.

Removing 2.5-inch hard drive from the rear bay

Prerequisites

- 1 Follow the safety guidelines listed in the Safety instructions section.
- 2 Complete the procedure listed in Before working inside your system.

 **CAUTION:** To maintain proper system cooling, all empty hard drive slots must have hard drive blanks installed.

Steps

- 1 Loosen the thumb screw.
- 2 Slide the HDD assembly out and pull up to remove.

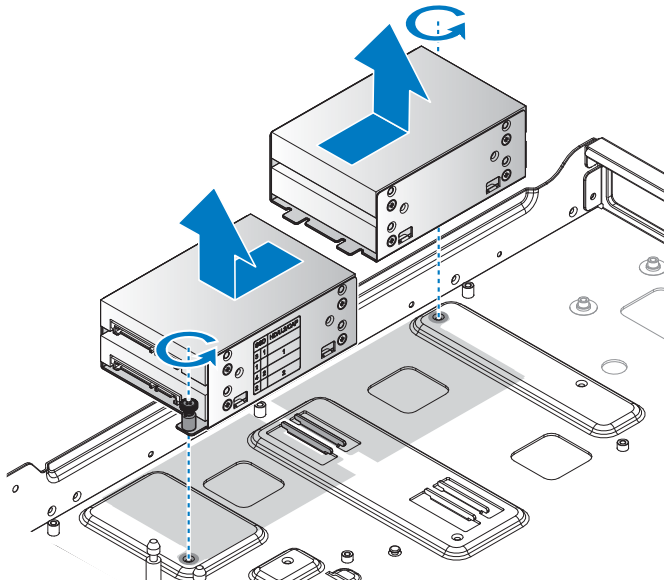

Figure 28. Removing the 2.5-inch HDD assembly

- 3 Remove the screws securing the HDD to the carrier.
- 4 Remove the HDD from the carrier.

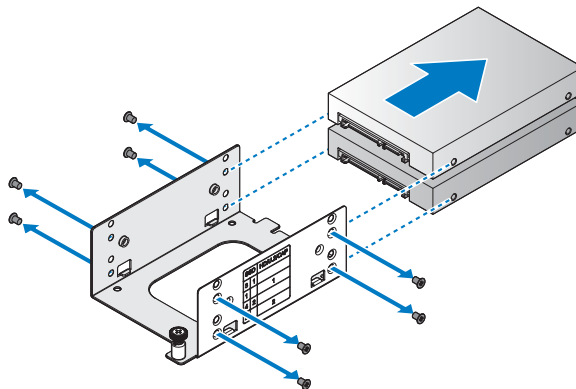

Figure 29. Removing the 2.5-inch HDD

Next steps

- 1 Install a 2.5-inch HDD into a rear bay.
- 2 Complete the procedure listed in After working inside your system.

Related Links

- Installing 2.5-inch hard drive in the rear bay

Installing 2.5-inch hard drive in the rear bay

Prerequisites

- 1 Follow the safety guidelines listed in the Safety instructions section.
- 2 Complete the procedure listed in Before working inside your system.

Steps

- 1 Align the HDD with the HDD carrier. Make sure the connectors are facing the front. Make sure the connectors are positioned as demonstrated in the following illustration.
- 2 Secure the HDD with the provided screws.

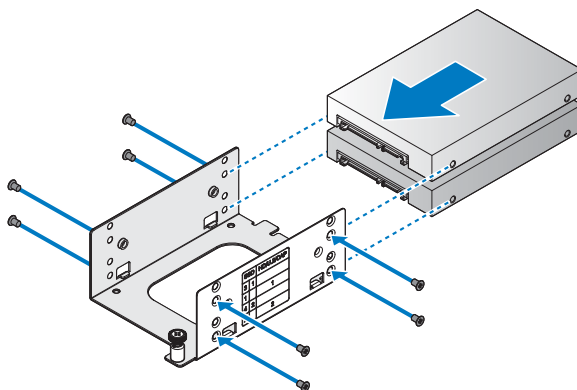

Figure 30. Installing the 2.5-inch HDD

Table 45. Assembly material

Description	Quantity	Torque (lbs/inch)
M3 screw	4 (1 per HDD)	6 ± 0.2

- 3 Align the HDD assembly in the chassis.
- 4 Install the HDD assembly and slide it to seat properly.
- 5 Secure with the thumb screw.

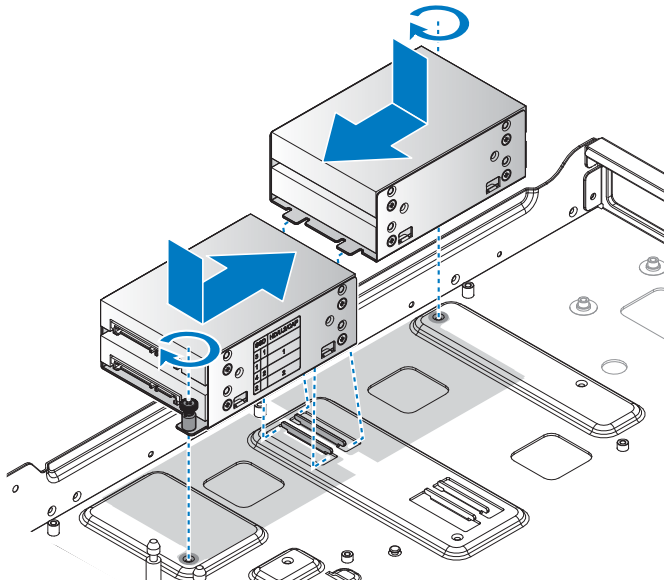

Figure 31. Installing the 2.5-inch HDD assembly

Next steps

- 1 Complete the procedure listed in After working inside your system.

Removing 3.5-inch hard drive from the rear bay

Prerequisites

NOTE: The procedure is available only for DSS 9620 server with 3.5-inch HDD.

- 1 Follow the safety guidelines listed in the Safety instructions section.
- 2 Complete the procedure listed in Before working inside your system.

CAUTION: To maintain proper system cooling, all empty hard drive slots must have hard drive blanks installed.

Steps

- 1 Pull up the plunger and slide the HDD assembly to release from the HDD tray.
- 2 Remove the HDD assembly from the HDD tray.

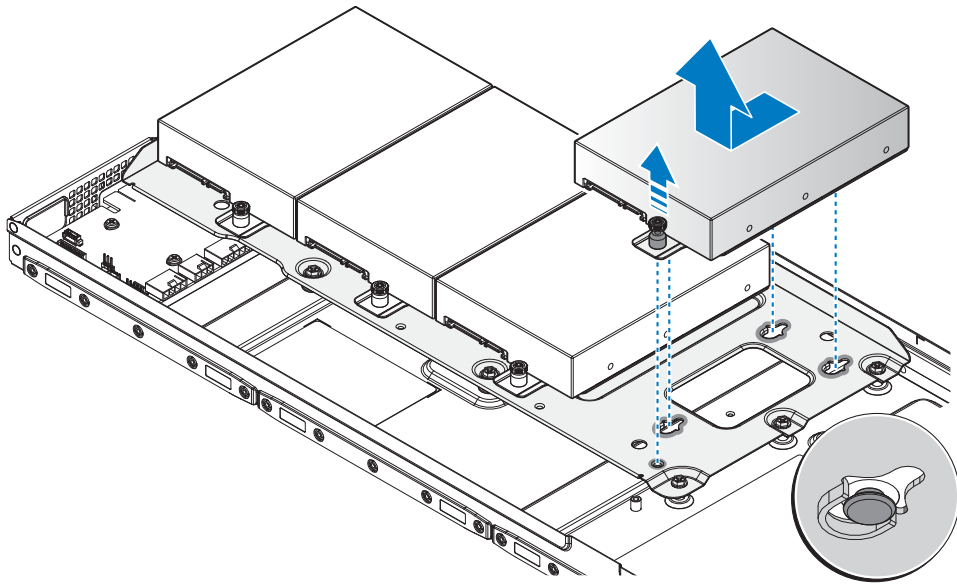

Figure 32. Removing the 3.5-inch HDD assembly

- 3** Remove the screws securing the HDD to the HDD carrier.
- 4** Remove the HDD from the HDD carrier.

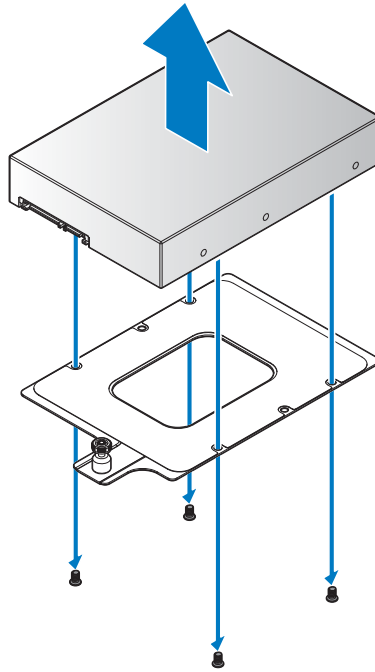

Figure 33. Removing the 3.5-inch HDD

- 5** Remove the screws securing the HDD tray to the standoffs on the server base.
- 6** Remove the HDD tray from the server.

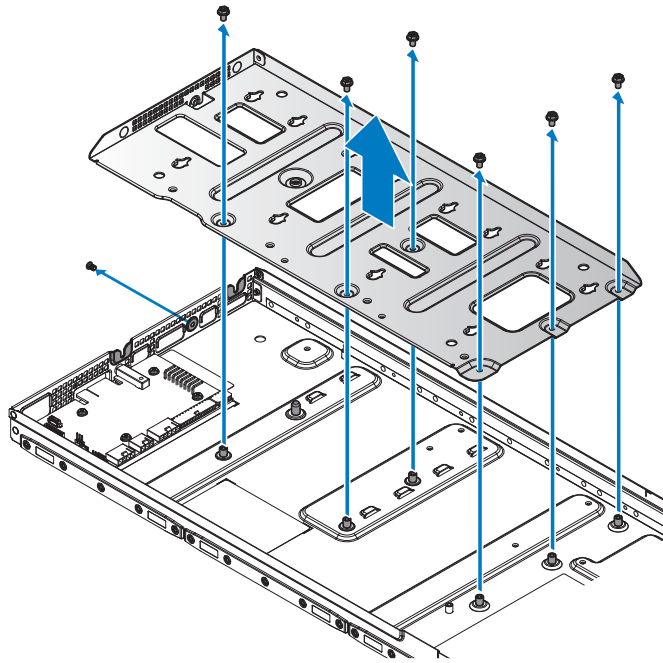

Figure 34. Removing the HDD tray

Next steps

- 1 Install the 3.5-inch HDD into a rear bay.
- 2 Complete the procedure listed in After working inside your system.

Related Links

- Removing 3.5-inch hard drive from the rear bay

Installing 3.5-inch hard drive in the rear bay

Prerequisites

 **NOTE:** The procedure is available only for DSS 9620 server with 3.5-inch HDD.

- 1 Follow the safety guidelines listed in the Safety instructions section.
- 2 Complete the procedure listed in Before working inside your system.

Steps

- 1 Align the HDD tray with the standoffs on the server base.
- 2 Secure the HDD tray with the provided screws.

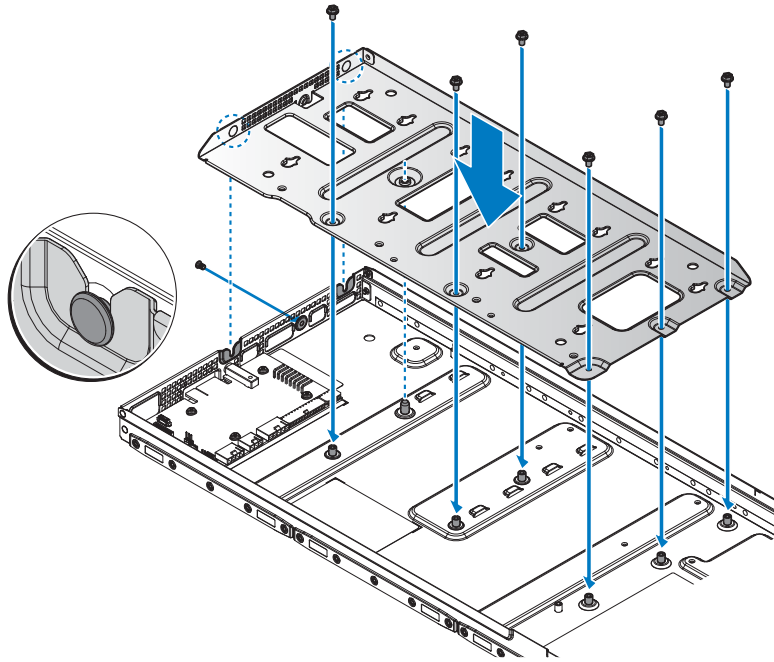

Figure 35. Installing the HDD tray

Table 46. Assembly material

Description	Quantity	Torque (lbs/inch)
#6-32 screw	7	6 ± 0.2

- 3** Align the HDD with the HDD carrier.
- 4** Secure the HDD with the provided screws.

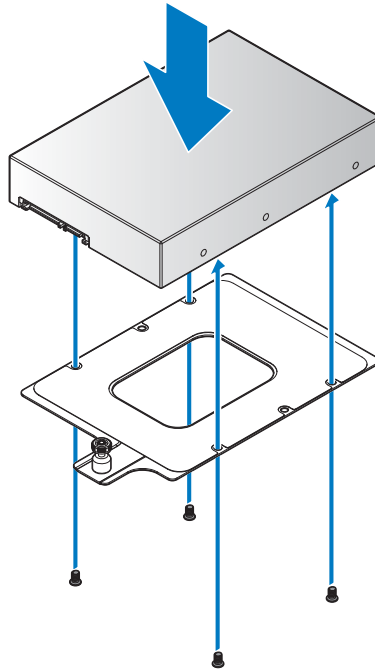

Figure 36. Installing the 3.5-inch HDD

Table 47. Assembly material

Description	Quantity	Torque (lbs/inch)
#6-32 screw	4 (1 per HDD)	6 ± 0.2

- 5 Align the standoffs on the HDD assembly with the keyholes on the HDD tray.
- 6 Slide the HDD assembly to lock in place.

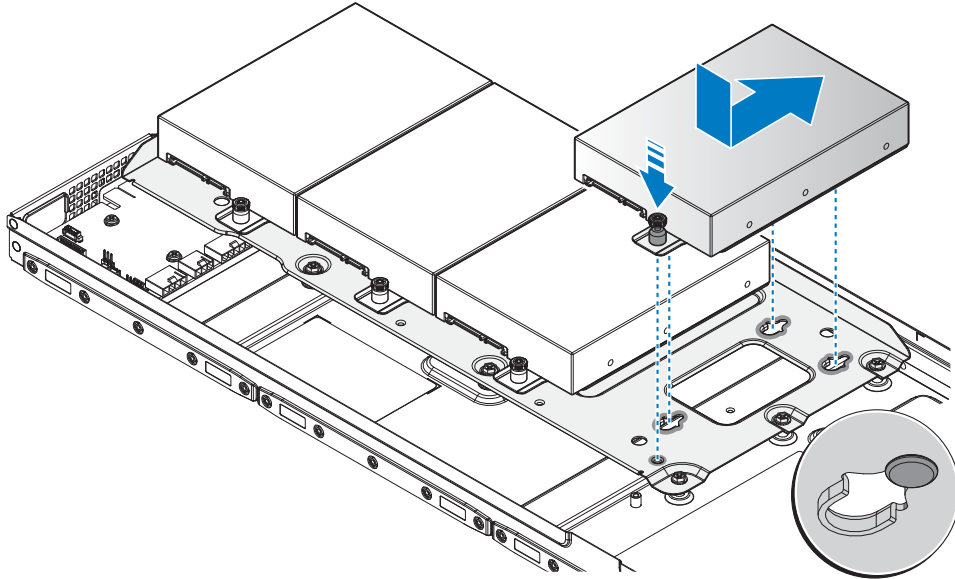

Figure 37. Installing the 3.5-inch HDD assembly

Next steps

- 1 Complete the procedure listed in After working inside your system.

Removing hot swappable hard drive

Prerequisites

- 1 Follow the safety guidelines listed in the Safety instructions section.
- 2 Complete the procedure listed in Before working inside your system.

CAUTION: To prevent data loss, ensure that your operating system supports hot swappable drive installation. See the documentation supplied with your operating system.

Steps

- 1 Press the release button to unlock the HDD assembly.
- 2 Pull the release latch of the HDD assembly to the fully open position.
- 3 Pull the HDD assembly out.

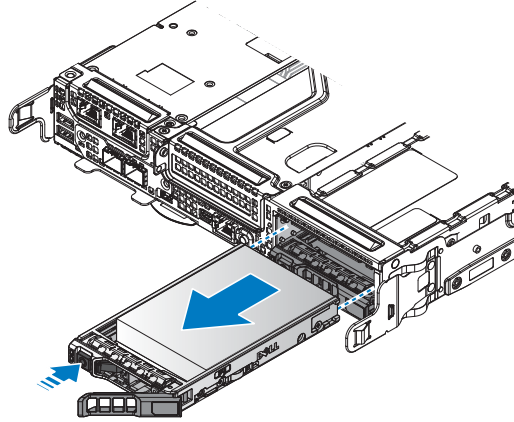

Figure 38. Removing the HDD assembly

- 4 Remove the screws securing the HDD to the HDD tray.
- 5 Remove the HDD module from the HDD tray.

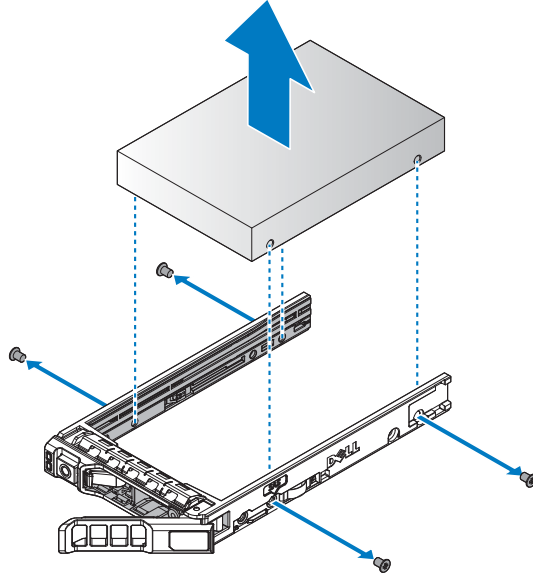

Figure 39. Removing the HDD module

Next steps

- 1 Install the hot swappable HDD.
- 2 Complete the procedure listed in After working inside your system.

NOTE: If you are not replacing the hard drive immediately, insert a hard drive blank in the empty hard drive slot.

Related Links

- [Installing hot swappable hard drive](#)

Installing hot swappable hard drive

Prerequisites

- 1 Follow the safety guidelines listed in the Safety instructions section.
- 2 Complete the procedure listed in Before working inside your system.

CAUTION: Use only hard drives that have been tested and approved for use with the hard drive backplane.

CAUTION: Combining SAS and SATA hard drives in the same RAID volume is not supported.

CAUTION: When installing a hard drive, ensure that the adjacent drives are fully installed. Inserting a hard drive carrier and attempting to lock its handle next to a partially installed carrier can damage the partially installed carrier's shield spring and make it unusable.

CAUTION: To prevent data loss, ensure that your operating system supports hot-swap drive installation. See the documentation supplied with your operating system.

CAUTION: When a replacement hot swappable hard drive is installed and the system is powered on, the hard drive automatically begins to rebuild. Make absolutely sure that the replacement hard drive is blank or contains data that you wish to have over-written. Any data on the replacement hard drive is immediately lost after the hard drive is installed.

Steps

- 1 Align the HDD to the HDD tray.
- 2 Secure the HDD by using the provided screws.

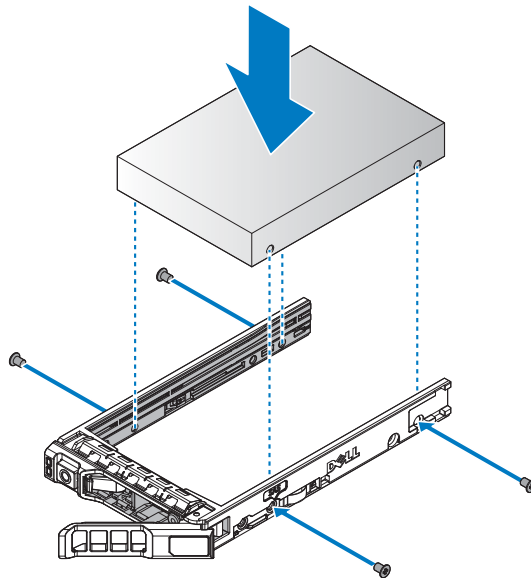

Figure 40. Installing the HDD module

Table 48. Assembly material

Description	Quantity	Torque (lbs/inch)
M3 screw	4 (1 per HDD)	6 ± 0.2

- 3 Extend the release latch on the HDD tray to the fully open position.
- 4 Insert the HDD assembly in the bay.
- 5 Close the latch to secure.

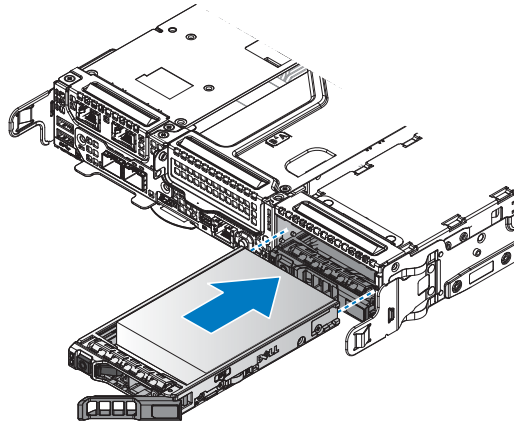

Figure 41. Installing the HDD assembly

Next steps

- 1 Complete the procedure listed in After working inside your system.

Server board

A server board (also known as the motherboard) is the main printed circuit board in the system with different connectors used to connect different components or peripherals of the system. A server board provides the electrical connections to the components in the system to communicate.

Removing server board

Prerequisites

CAUTION: Do not attempt to remove the TPM plug-in module from the server board. Once the TPM plug-in module is installed, it is cryptographically bound to that specific server board. Any attempt to remove an installed TPM plug-in module breaks the cryptographic binding, and it cannot be reinstalled or installed on another server board.

- 1 Follow the safety guidelines listed in the Safety instructions section.
- 2 Complete the procedure listed in Before working inside your system.
- 3 Remove the PCIe card.
- 4 Remove the mezzanine card.

- 5 Remove the OCP card.
- 6 Remove the expansion riser on slot 5.
- 7 Remove memory modules.
- 8 Remove heat sinks and processors.

Steps

- 1 Disconnect all cables from the server board.
- 2 Remove the securing screws from the server board.
- 3 Disconnect the cable clip rings.

 **NOTE:** The location of cable clips may differ depending on the models.

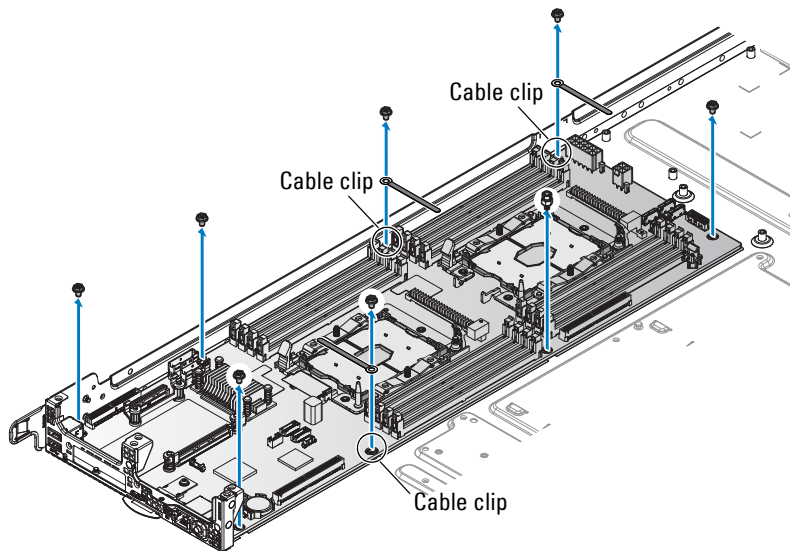

Figure 42. Removing server board securing screws

- 4 Grasp the back of the server board and tilt upward. Do not lift the back of the server board completely to prevent damage to the components and I/O ports on the front.

 **CAUTION:** Do not lift the server board by holding a memory module slot, any other connector, or component.

- 5 Pull the server board back to release the I/O ports from the chassis, and lift the server board out to remove.
- 6 Place the server board in an antistatic bag.

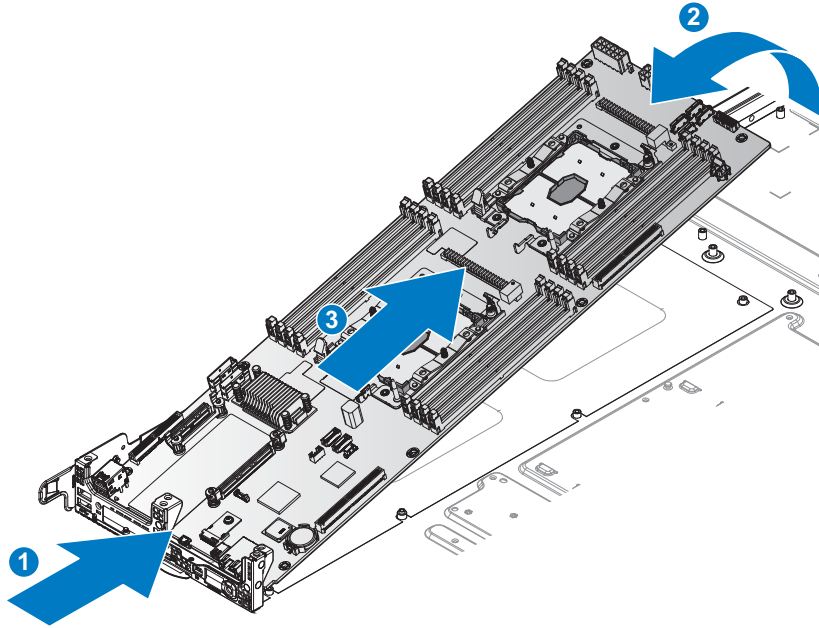

Figure 43. Removing a server board

Next steps

- 1 Install the server board.
- 2 Complete the procedure listed in After working inside your system.

Related Links

- Removing PCIe card
- Removing mezzanine card, Removing Mini PERC, Removing OCP card from slot 1, Removing x8 PCIe M.2 card, or Removing x8 SATA M.2 card
- Removing OCP card from slot 3
- Removing NVMe riser, Removing x16 PCIe M.2 card, or Removing x16 SATA M.2 card
- Removing memory module
- Removing heat sink
- Removing processor
- Installing server board

Installing server board

Prerequisites

- 1 Follow the safety guidelines listed in the Safety instructions section.
- 2 Complete the procedure listed in Before working inside your system.

Steps

- 1 Remove the new server board from its antistatic bag and hold by the edges.
- 2 If removed, install the Trusted Platform Module (TPM). For information about how to install the TPM, see the Installing trusted platform module section. For more information about the TPM, see the Trusted platform module section.



NOTE: The TPM plug-in module once installed is attached to the server board and cannot be removed. In the event of a server board replacement, a TPM plug-in module is provided along with the server board for all systems that have a TPM.

- 3 Align the I/O ports on the server board with the front of the server.
- 4 Angle the server board into the I/O ports. Make sure the ports on the server board are seated correctly in the chassis.
- 5 Gently lower the server board in the chassis.
- 6 After the server board is in place, slide it towards the grill until the server board is seated in place and the screw holes (server board and chassis) are aligned.

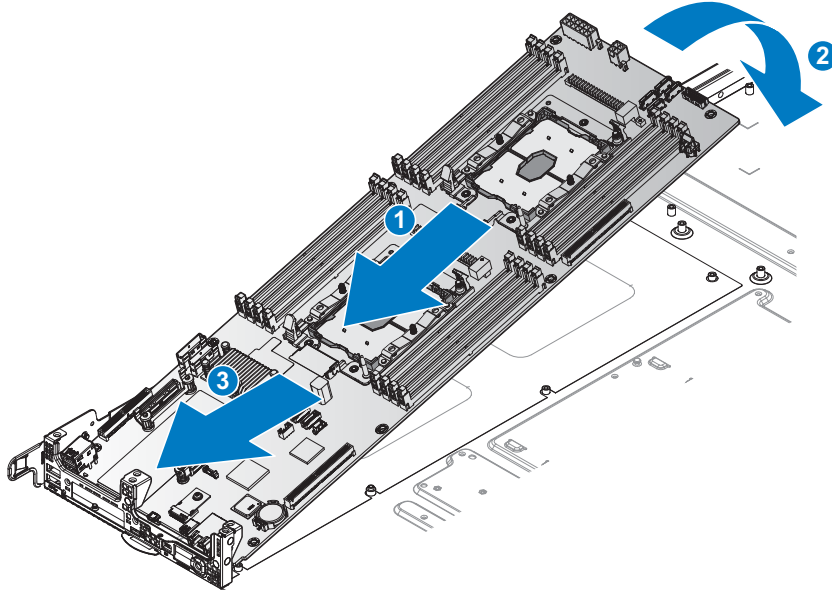



Figure 44. Installing the server board

- 7 Secure the two marked locations with the provided shoulder screws.
- 8 Insert the cable clips in the marked location and secure with the provided screws.
- 9 Attach the remaining screws to secure the server board to the chassis.
- 10 Connect all cables to the server board.

 **NOTE:** The location of cable clips may differ depend on the models.

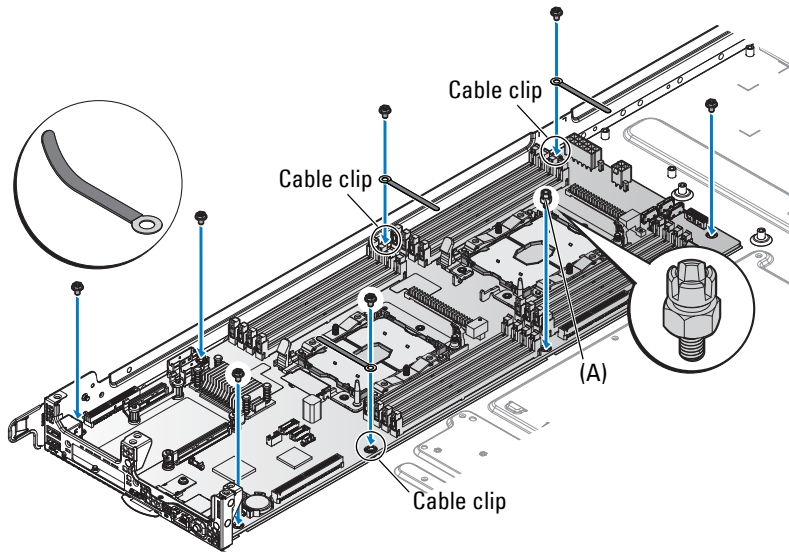

Figure 45. Securing the server board

Table 49. Assembly material

Description	Quantity	Torque (lbs/inch)
M3 screw	7	6 ± 0.2
Special screw (A)	1	6 ± 0.2

Next steps

- 1 Install heat sinks and processors.
- 2 Install memory modules.
- 3 Install the expansion riser to slot 5.
- 4 Install the OCP card.
- 5 Install the mezzanine card.
- 6 Install the PCIe card.
- 7 Complete the procedure listed in After working inside your system.

Related Links

- Installing processor
- Installing heat sink
- Installing memory module

- Installing NVMe riser, Installing x16 PCIe M.2 card, or Installing x16 SATA M.2 card
- Installing OCP card into slot 3
- Installing mezzanine card, Installing Mini PERC, Installing OCP card into slot 1, Installing x8 PCIe M.2 card, or Installing x8 SATA M.2 card
- Installing PCIe card

Trusted platform module

Trusted Platform Module (TPM) is a dedicated microprocessor designed to secure hardware by integrating cryptographic keys into devices. Software can use a Trusted Platform Module to authenticate hardware devices. Because each TPM chip has a unique and secret RSA key which is embedded during the manufacture of the TPM, and it is capable of performing platform authentication operation.

 **CAUTION:** Do not attempt to remove the Trusted Platform Module (TPM) from the server board. After the TPM is installed, it is cryptographically bound to that specific server board. Any attempt to remove an installed TPM breaks the cryptographic binding, and it cannot be re-installed or installed on another server board.

Installing trusted platform module

Prerequisites

 **CAUTION:** Do not attempt to remove the Trusted Platform Module (TPM) from the server board. Once the TPM is installed, it is cryptographically bound to that specific server board. Any attempt to remove an installed TPM breaks the cryptographic binding, and it cannot be re-installed or installed on another server board.

 **NOTE:** This is a Field Replaceable Unit (FRU). Removal and installation procedures should be performed only by Dell certified service technicians.

- 1 Follow the safety guidelines listed in the Safety instructions section.
- 2 Complete the procedure listed in Before working inside your system.
- 3 Remove the PCIe card.

Steps

- 1 Align the trust platform module into the server board connector and insert it.

 **NOTE:** To locate the TPM connector on the server board, see Jumpers and connectors section.

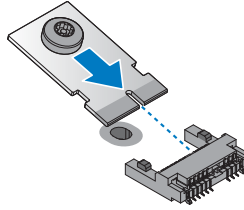

Figure 46. Inserting the trust platform module

- 2 Flip down the TPM. Make sure it is secured on the server board.

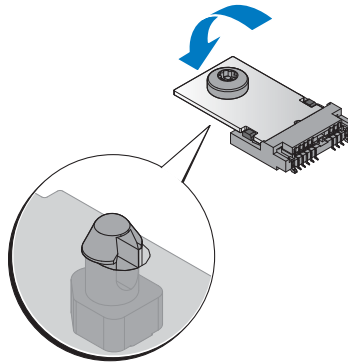

Figure 47. Securing the TPM

Next steps

- 1 Install the PCIe card.
- 2 Complete the procedure listed in After working inside your system.

Related Links

- Removing PCIe card
- Installing PCIe card

Initializing TPM for BitLocker users

For more information, see <http://technet.microsoft.com/en-us/library/cc753140.aspx>.

The TPM Status changes to Enabled, Activated.

Initializing TPM for TXT users

- 1 While booting your system, press F2 to enter System Setup.
- 2 On the System Setup Main Menu screen, click System BIOS > System Security Settings.

- 3 From the **TPM Security** option, select **On with Pre-boot Measurements**.
- 4 From the **TPM Command** option, select **Activate**.
- 5 Save the settings.
- 6 Restart your system.
- 7 Enter **System Setup** again.
- 8 On the **System Setup Main Menu** screen, click **System BIOS > System Security Settings**.
- 9 From the **Intel TXT** option, select **On**.

Restoring the Service Tag by using the Easy Restore feature

By using the Easy Restore feature, you can restore your Service Tag, license, UEFI configuration, and the system configuration data after replacing the server board. All data is automatically backed up in a backup flash device rSPI card automatically. If BIOS detects a new server board and the Service Tag in the backup flash device rSPI card, BIOS prompts the user to restore the backup information.

- 1 Turn on the system.
If BIOS detects a new server board, and if the Service Tag is present in the backup flash device rSPI card, BIOS displays the Service Tag, the status of the license, and the **UEFI Diagnostics** version.
- 2 Perform one of the following steps:
 - Press **Y** to restore the Service Tag, license, and diagnostics information.
 - Press **N** to navigate to the Dell Lifecycle Controller based restore options.
 - Press **F10** to restore data from a previously created **Hardware Server Profile**.

After the restore process is complete, BIOS prompts to restore the system configuration data.

- 3 Perform one of the following steps:
 - Press **Y** to restore the Service Tag, license, and diagnostics information.

After the restore process is complete, BIOS prompts to restore the system configuration data.

- 4 Perform one of the following steps:
 - Press **Y** to restore the system configuration data.
 - Press **N** to use the default configuration settings.

After the restore process is complete, the system restarts.

Mini PERC battery

Removing Mini PERC battery

Prerequisites

- 1 Follow the safety guidelines listed in the Safety instructions section.

- 2 Complete the procedure listed in Before working inside your system.

Steps

- 1 Disconnect the Mini PERC and PERC battery cables.
- 2 Press the release latch to release the Mini PERC battery.
- 3 Slide the Mini PERC battery out of the air shroud to remove.

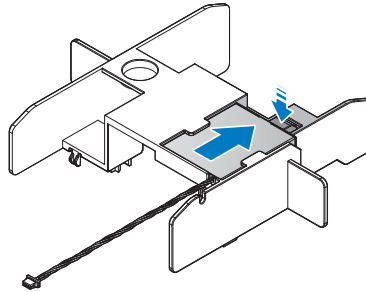

Figure 48. Removing the Mini PERC battery

Next steps

- 1 Install the Mini PERC battery.
- 2 Complete the procedure listed in After working inside your system.

Related Links

- [Installing Mini PERC battery](#)

Installing Mini PERC battery

⚠ WARNING: There is a danger of a new battery exploding if it is incorrectly installed. Replace the battery only with the same or equivalent type recommended by the manufacturer. For more information, see the safety information that shipped with your system.

⚠ CAUTION: Many repairs may only be done by a certified service technician. You should only perform troubleshooting and simple repairs as authorized in your product documentation, or as directed by the online or telephone service and support team. Damage due to servicing that is not authorized by Dell is not covered by your warranty. Read and follow the safety instructions that are shipped with your product.

Prerequisites

- 1 Follow the safety guidelines listed in the Safety instructions section.
- 2 Complete the procedure listed in Before working inside your system.

Steps

- 1 Slide the Mini PERC battery into the slot on the air shroud. Make sure the cable is routed through the top of the air shroud.

⚠ WARNING: Do not use the cables on the PERC battery to pull the PERC battery in place to prevent fraying the cables.

- 2 Continue to slide the PERC battery into the air shroud until it is fully flush in place.

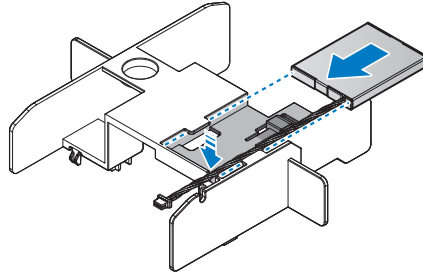

Figure 49. Installing the Mini PERC battery

- 3 Connect the PERC battery and Mini PERC cables.

Next steps

- 1 Complete the procedure listed in After working inside your system.

Supercap

Removing Microsemi supercap

Prerequisites

- 1 Follow the safety guidelines listed in the Safety instructions section.
- 2 Complete the procedure listed in Before working inside your system.

Steps

- 1 Locate the supercap battery and disconnect the cable.

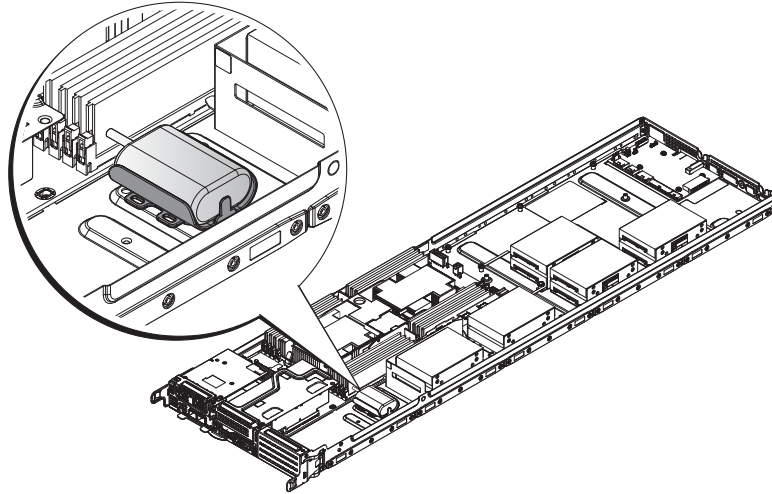

Figure 50. Locating the supercap

- 2 Grasp the battery and lift it up to remove it from the holder.

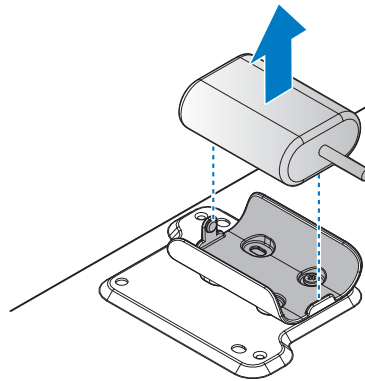

Figure 51. Removing the supercap battery

Next steps

- 1 Replace the Microsemi supercap battery.
- 2 Complete the procedure listed in After working inside your system.

Related Links

- [Installing Microsemi supercap](#)

Installing Microsemi supercap

Prerequisites

- 1 Follow the safety guidelines listed in the Safety instructions section. Safety instructions.
- 2 Complete the procedure listed in Before working inside your system.

Steps

- 1 Locate the place holder in the assigned location. The screw holes on the chassis and holder align when the holder is placed correctly.

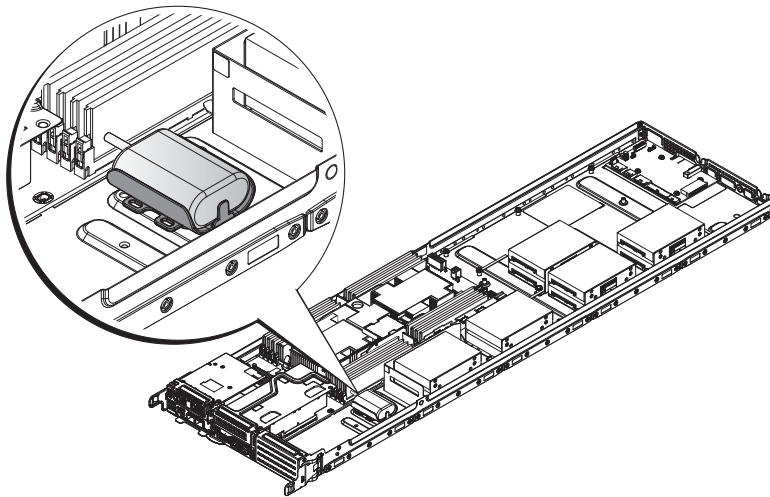

Figure 52. Locating the supercap

- 2 Insert the screws in the holder and tighten to secure the holder in place.

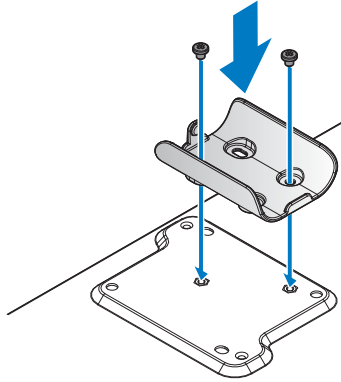

Figure 53. Installing the battery holder

Table 50. Assembly material

Description	Quantity	Torque (lbs/inch)
#6-32 screw	2	6 ± 0.2

- 3 Position the cable to allow access for front-side routing.
- 4 Insert the battery into the holder and gently press it down until it is secured.

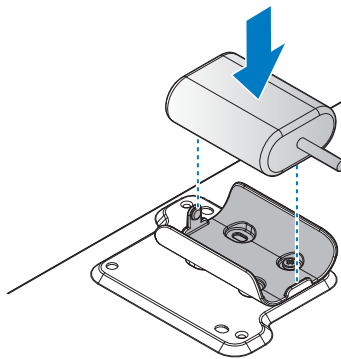

Figure 54. Installing the battery into the holder

Next steps

- 1 Complete the procedure listed in After working inside your system.

Removing Broadcom supercap

Prerequisites

- 1 Follow the safety guidelines listed in the Safety instructions section.
- 2 Complete the procedure listed in Before working inside your system.

Steps

- 1 Locate the supercap battery and disconnect the supercap cable.

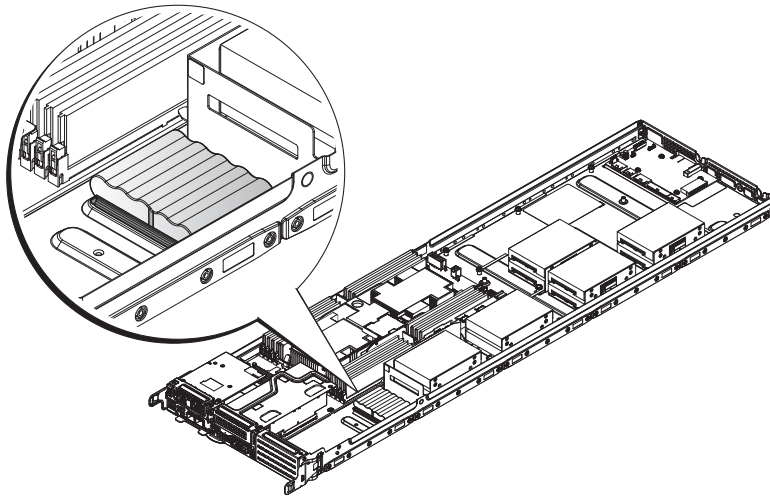

Figure 55. Locating the supercap

- 2 Grasp the one end of the battery and lift it up to remove it from the holder.

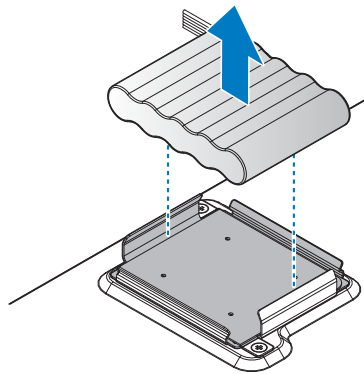

Figure 56. Removing the supercap battery

Next steps

- 1 Replace the Broadcom supercap battery.
- 2 Complete the procedure listed in After working inside your system.

Related Links

- Installing Broadcom supercap

Installing Broadcom supercap

Prerequisites

- 1 Follow the safety guidelines listed in the Safety instructions section. Safety instructions.
- 2 Complete the procedure listed in Before working inside your system.

Steps

- 1 Locate the place holder in the assigned location. The screw holes on the chassis and holder align when the holder is placed correctly.

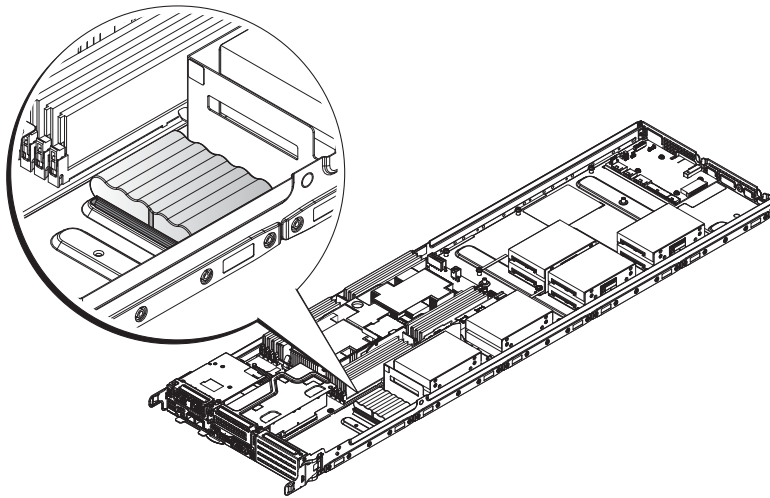

Figure 57. Locating the supercap

- 2 Insert the screws in the holder and tighten to secure the holder in place.

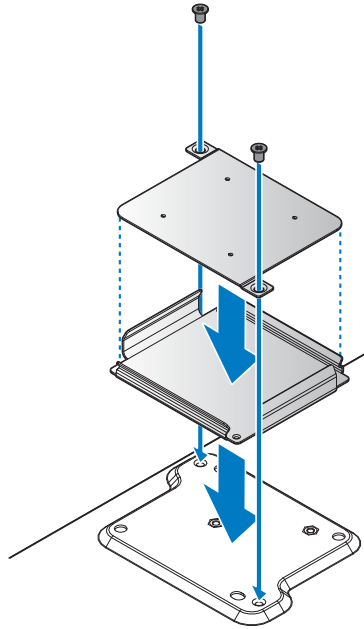

Figure 58. Installing the battery holder

Table 51. Assembly material

Description	Quantity	Torque (lbs/inch)
M3 Screw	2	6 ± 0.2

- 3** Position the cable to allow access for front-side routing.
- 4** Insert the battery into the holder and gently press it down until it is secured.

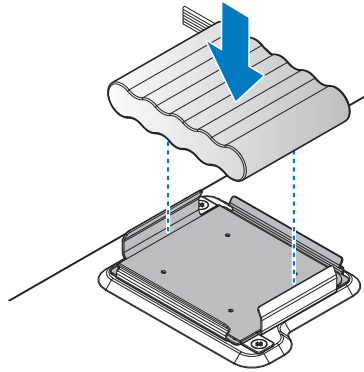

Figure 59. Installing the battery into the holder

Next steps

- 1 Complete the procedure listed in After working inside your system.

Mezzanine card and Mini PERC

Removing mezzanine card

Prerequisites

- 1 Ensure that you read the Safety instructions.
- 2 Complete the procedure listed in Before working inside your system.

Steps

- 1 Remove the securing screws from the mezzanine card assembly.
- 2 Remove the mezzanine card assembly from the chassis.



NOTE: You must install an expansion card filler cover over an empty expansion slot to maintain Federal Communications Commission (FCC) certification of the system. The covers also keep dust and dirt out of the system and aid in proper cooling and airflow inside the system.

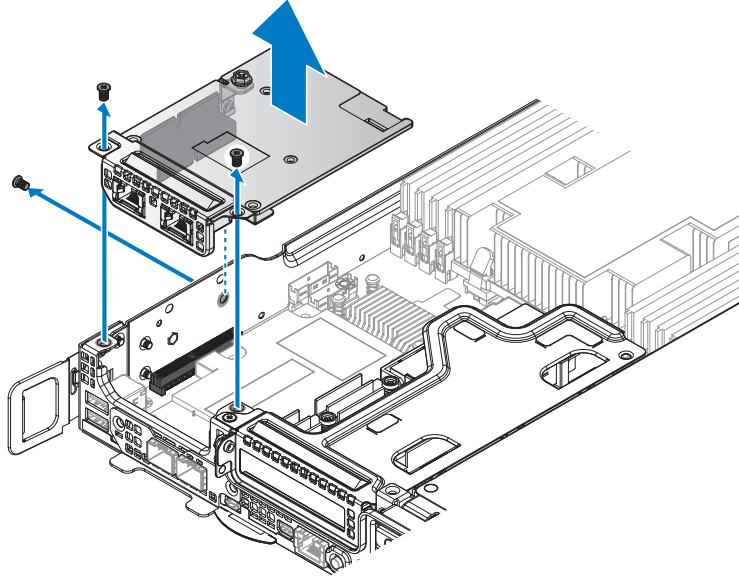

Figure 60. Removing the mezzanine card assembly

- 3 Remove the bridge board from the mezzanine card assembly.

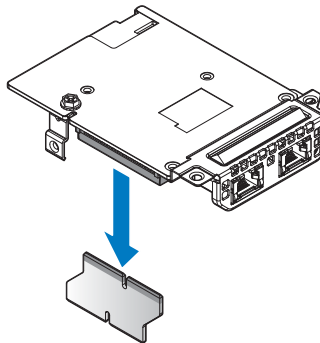

Figure 61. Removing the bridge board from the mezzanine card

- 4 Remove the securing screws from the mezzanine brackets.
- 5 Remove the support bracket and slot cover from the mezzanine card.

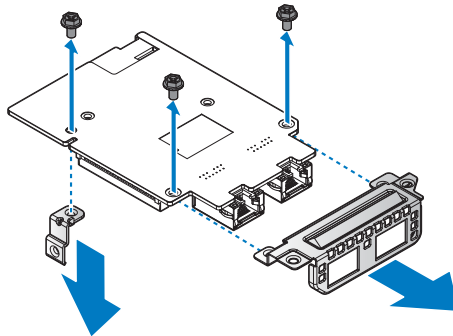

Figure 62. Removing the support bracket and slot cover

Next steps

- 1 Install the mezzanine card.
- 2 Complete the procedure listed in *After working inside your system*.

Related Links

- [Installing mezzanine card](#)

Installing mezzanine card

Prerequisites

- 1 Ensure that you read the *Safety instructions*.
- 2 Complete the procedure listed in *Before working inside your system*.

Steps

- 1 Align the holes on mezzanine card with the holes on support bracket and slot cover.
- 2 Secure the support bracket and slot cover with screws.

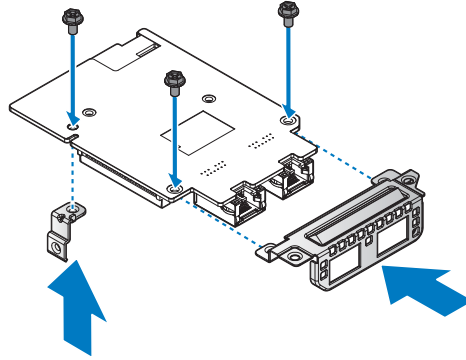

Figure 63. Installing the support bracket and slot cover

Table 52. Assembly material

Description	Quantity	Torque (lbs/inch)
#6-32 screw	3	6 ± 0.2

- 3 Align the bridge board with the mezzanine card connector.
- 4 Install the bridge board.

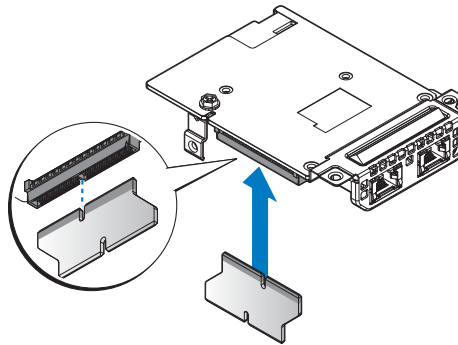

Figure 64. Installing the bridge board on the mezzanine card

- 5 Align the mezzanine card assembly with the screw posts on the chassis and the connector on the server board.
- 6 Press the mezzanine card assembly into the server board connector until it is fully seated.
- 7 Secure the mezzanine card assembly with provided screws.

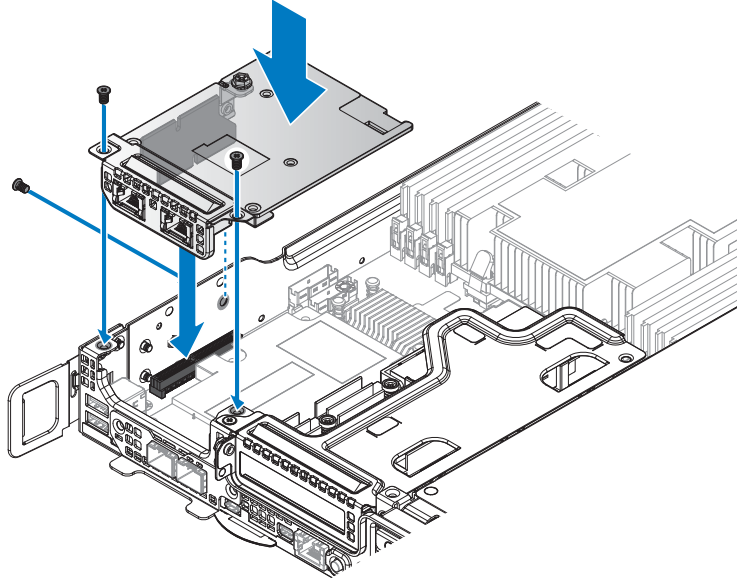

Figure 65. Installing the mezzanine card assembly

Table 53. Assembly material

Description	Quantity	Torque (lbs/inch)
#6-32 screw	3	6 ± 0.2

Next steps

- 1 Complete the procedure listed in After working inside your system.

Removing Mini PERC

Prerequisites

- 1 Ensure that you read the Safety instructions.
- 2 Complete the procedure listed in Before working inside your system.

Steps

- 1 Remove the securing screws from the Mini PERC assembly.
- 2 Remove the Mini PERC assembly from the chassis.

NOTE: You must install an expansion card filler cover over an empty expansion slot to maintain Federal Communications Commission (FCC) certification of the system. The covers also keep dust and dirt out of the system and aid in proper cooling and airflow inside the system.

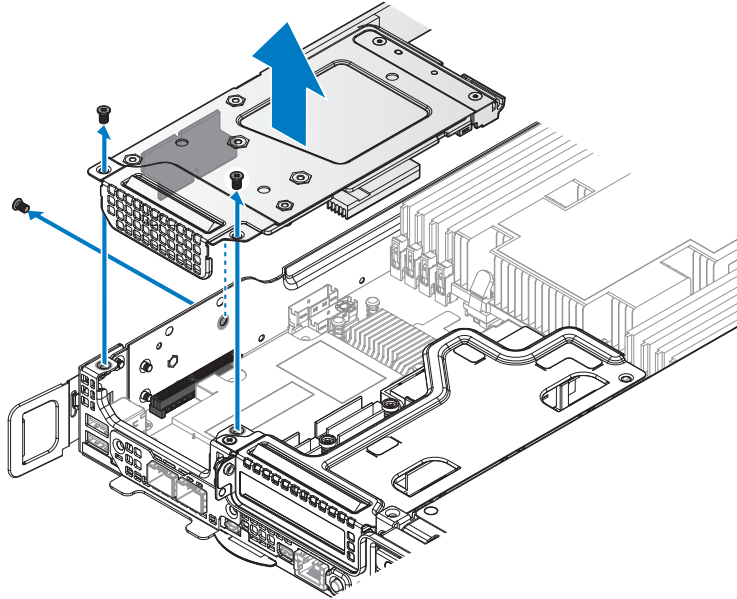

Figure 66. Removing the Mini PERC assembly

- 3 Remove the bridge board from the Mini PERC assembly.

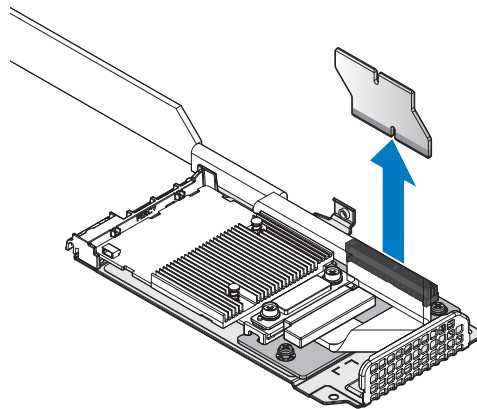

Figure 67. Removing the bridge board from the Mini PERC assembly

- 4 Loosen the captive screws securing the Mini PERC cable and the Mini PERC card.

- 5 Remove the Mini PERC cable.
- 6 Grasp the ends of the Mini PERC card and remove it.

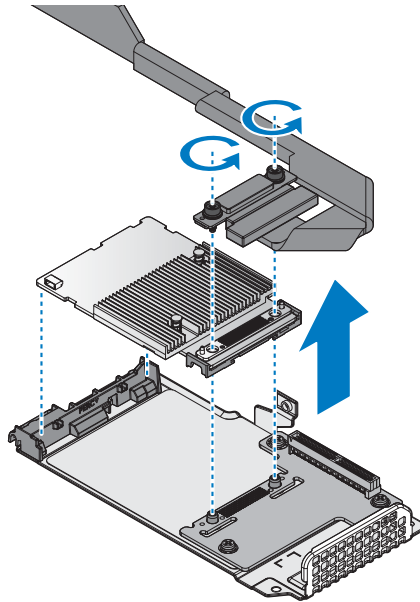

Figure 68. Removing the Mini PERC cable and card

- 7 Remove the screws securing the riser board.
- 8 Remove the bezel and riser board from the mezzanine bracket.

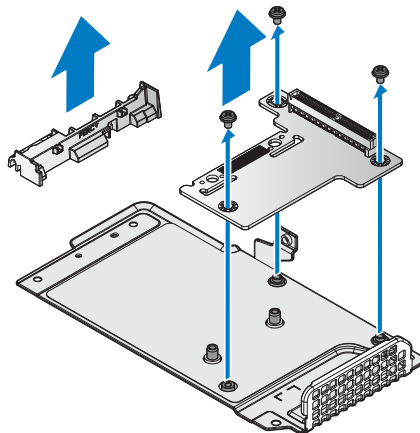

Figure 69. Removing the bezel and riser board

Next steps

- 1 Install the Mini PERC.
- 2 Complete the procedure listed in After working inside your system.

Related Links

- Installing Mini PERC

Installing Mini PERC

Prerequisites

- 1 Ensure that you read the Safety instructions.
- 2 Complete the procedure listed in Before working inside your system.

Steps

- 1 Align the holes on riser board with the holes on mezzanine brackets.
- 2 Secure the mezzanine brackets with screws.
- 3 Align the bezel with the mezzanine bracket and install.

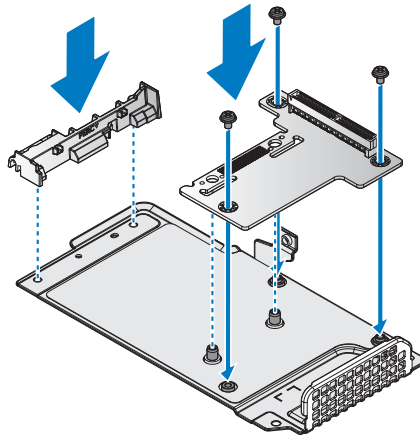

Figure 70. Installing the bezel and riser board

Table 54. Assembly material

Description	Quantity	Torque (lbs/inch)
#6-32 screw	3	6 ± 0.2

- 4 Align the Mini PERC on the riser board making sure the screw holes line up.

- 5 Install the Mini PERC card on the bezel and riser board.
- 6 Place the PERC cable over the Mini PERC connectors and install.
- 7 Secure the Mini PERC cable and the Mini PERC with the captive screws.

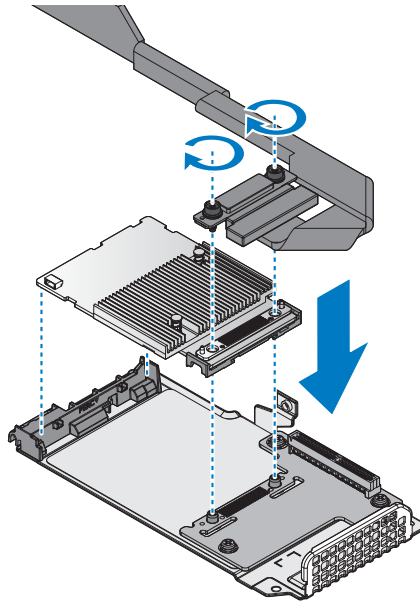

Figure 71. Assembling the Mini PERC card and cable on the bracket

Table 55. Assembly material

Description	Quantity	Torque (lbs/inch)
FIX screw	2	6 ± 0.2

- 8 Align the bridge board with the riser board connector.
- 9 Install the bridge board.

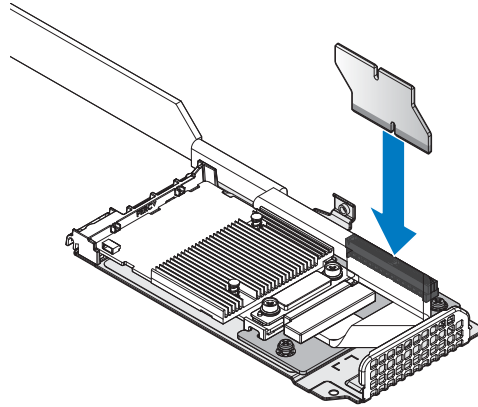

Figure 72. Installing the bridge board on the Mini PERC assembly

- 10** Turn the Mini PERC assembly over and align it with the screw posts on the chassis and the connector on the server board.
- 11** Press the Mini PERC assembly into the server board connector until it is fully seated.
- 12** Secure the Mini PERC assembly with the provided screws.

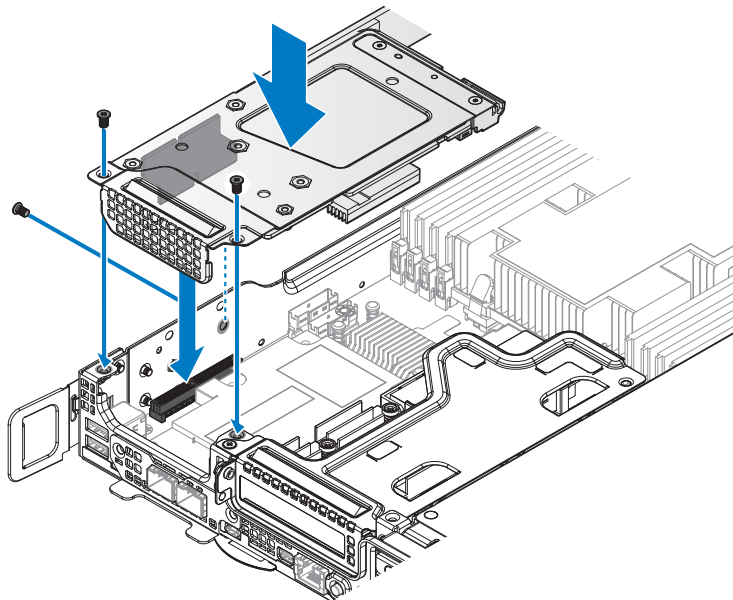

Figure 73. Installing the Mini PERC assembly

Table 56. Assembly material

Description	Quantity	Torque (lbs/inch)
#6-32 screw	3	6 ± 0.2

Next steps

- 1 Complete the procedure listed in After working inside your system.

M.2 SSD

Removing x8 PCIe M.2 card

Prerequisites

- 1 Ensure that you read the Safety instructions.
- 2 Complete the procedure listed in Before working inside your system.

Steps

- 1 Remove the securing screws from the PCIe M.2 assembly.
- 2 Remove the PCIe M.2 assembly from the chassis.



NOTE: You must install an expansion card filler cover over an empty expansion slot to maintain Federal Communications Commission (FCC) certification of the system. The covers also keep dust and dirt out of the system and aid in proper cooling and airflow inside the system.

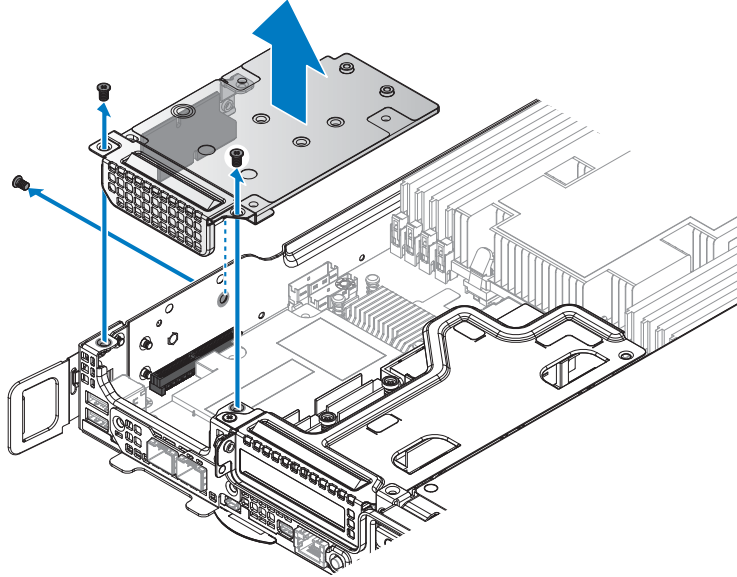

Figure 74. Removing the PCIe M.2 assembly

- 3 Remove the bridge board from the PCIe M.2 assembly.

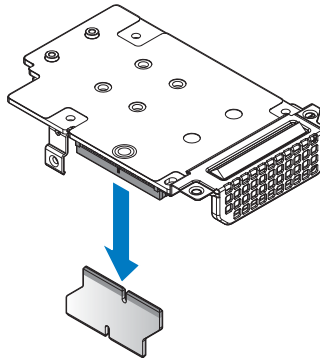

Figure 75. Removing the bridge board from the mezzanine card

- 4 Flip over the PCIe M.2 assembly.
- 5 Loosen the screw securing the PCIe M.2 card to the M.2 SSD board.
- 6 The M.2 SSD board pops up. Grasp the card and slide it out.

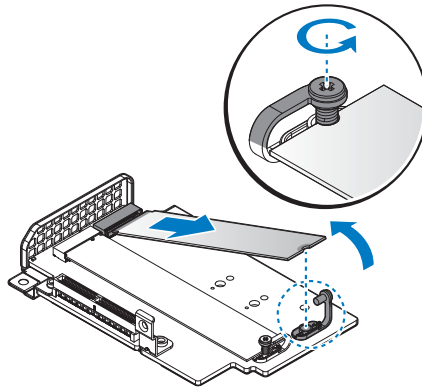

Figure 76. Removing the M.2 SSD board

- 7 Remove the securing screws from the mezzanine brackets.
- 8 Remove the support bracket and slot cover from the PCIe M.2 card.

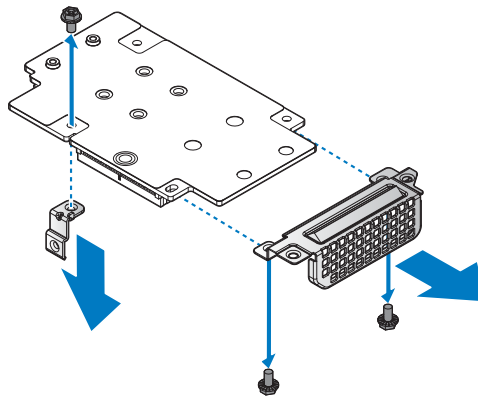

Figure 77. Removing the support bracket and slot cover

Next steps

- 1 Install the PCIe M.2 card.
- 2 Complete the procedure listed in After working inside your system.

Related Links

- [Installing x8 PCIe M.2 card](#)

Installing x8 PCIe M.2 card

Prerequisites

- 1 Ensure that you read the Safety instructions.
- 2 Complete the procedure listed in Before working inside your system.

Steps

- 1 Align the holes on the PCIe M.2 card with the holes on support bracket and slot cover.
- 2 Secure the support bracket and slot cover with screws.

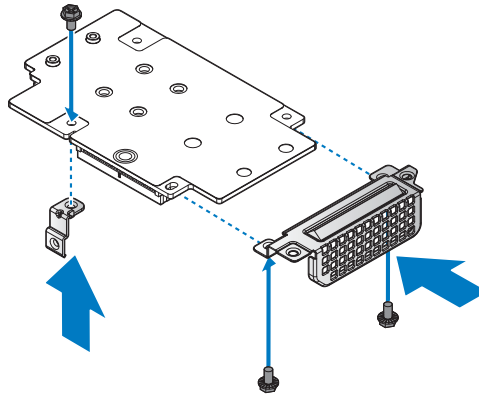

Figure 78. Installing the support bracket and slot cover

Table 57. Assembly material

Description	Quantity	Torque (lbs/inch)
#6-32 screw	3	6 ± 0.2

- 3 Flip over the PCIe M.2 assembly.
- 4 Align the M.2 SSD board with the protrusion in the PCIe M.2 card.
- 5 Insert the M.2 SSD until it is fully seated in the connector.
- 6 Lower the M.2 SSD board and hold it in place.
- 7 Secure the M.2 SSD board to the PCIe M.2 card with the captive screw.

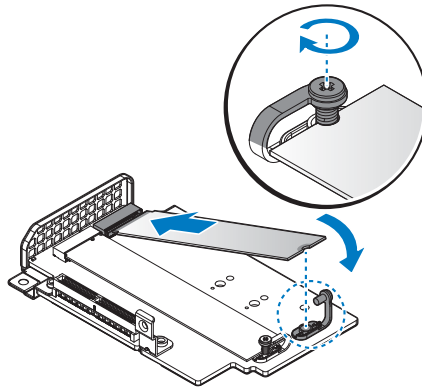

Figure 79. Installing the M.2 SSD board

- 8 Align the bridge board in the PCIe M.2 card connector.
- 9 Install the bridge board.

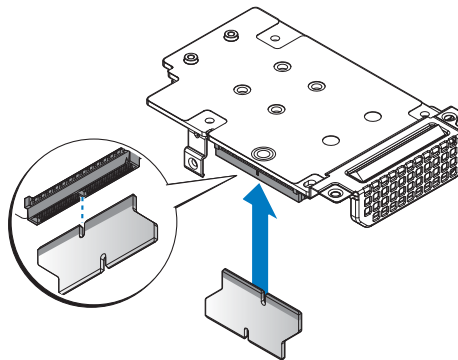

Figure 80. Installing the bridge board on the mezzanine card

- 10 Align the PCIe M.2 assembly with the screw posts on the chassis and the connector on the server board.
- 11 Press the PCIe M.2 assembly into the server board connector until it is fully seated.
- 12 Secure the PCIe M.2 assembly with provided screws.

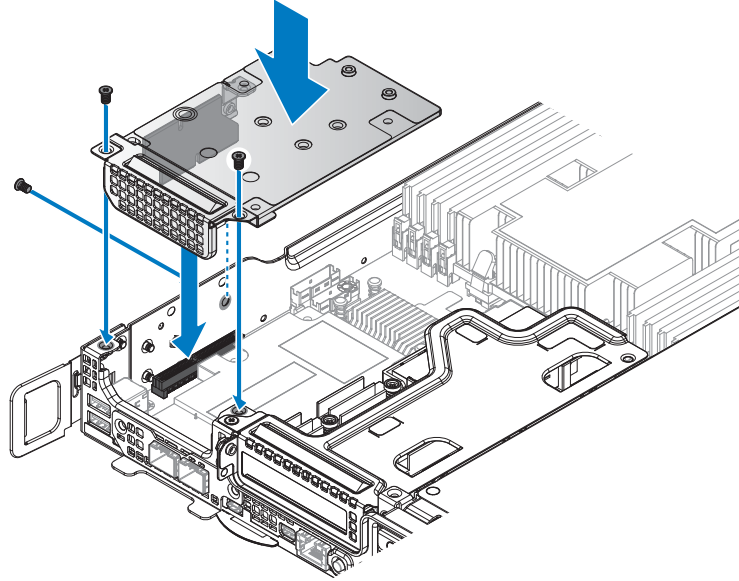

Figure 81. Installing the PCIe M.2 assembly

Table 58. Assembly material

Description	Quantity	Torque (lbs/inch)
#6-32 screw	3	6 ± 0.2

Next steps

- 1 Complete the procedure listed in After working inside your system.

Removing x8 SATA M.2 card

Prerequisites

- 1 Ensure that you read the Safety instructions.
- 2 Complete the procedure listed in Before working inside your system.

Steps

- 1 Remove the securing screws from the SATA M.2 assembly.
- 2 Remove the SATA M.2 assembly from the chassis.



NOTE: You must install an expansion card filler cover over an empty expansion slot to maintain Federal Communications Commission (FCC) certification of the system. The covers also keep dust and dirt out of the system and aid in proper cooling and airflow inside the system.

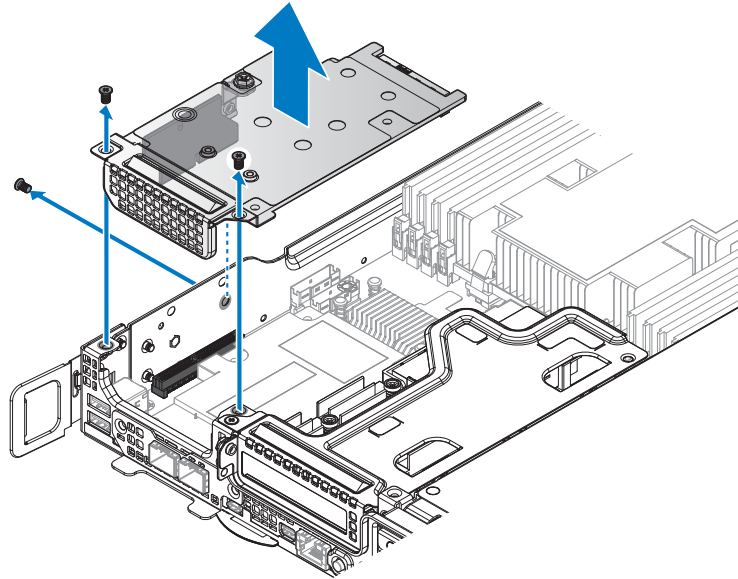

Figure 82. Removing the SATA M.2 assembly

- 3 Remove the bridge board from the SATA M.2 assembly.

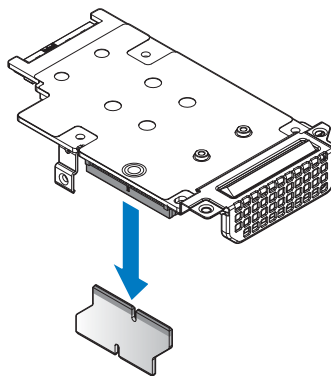

Figure 83. Removing the bridge board from the mezzanine card

- 4 Flip over the SATA M.2 assembly.
- 5 Loosen the screw securing the SATA M.2 card and M.2 SSD board.

- 6 The M.2 SSD board pops up. Grasp the board and slide it out.

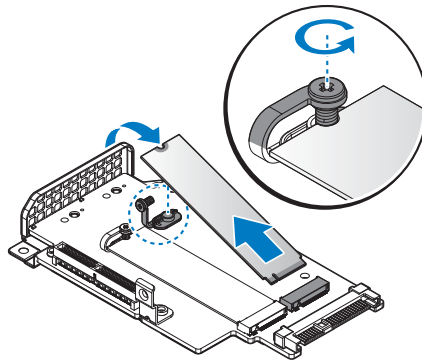

Figure 84. Removing the M.2 SSD board

- 7 Remove the securing screws from the mezzanine brackets.
- 8 Remove the support bracket and slot cover from the SATA M.2 card.

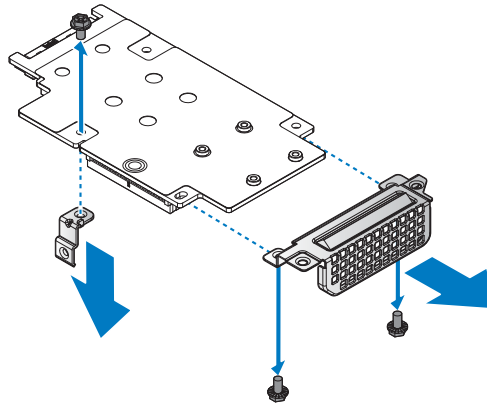

Figure 85. Removing the support bracket and slot cover

Next steps

- 1 Install the SATA M.2 card.
- 2 Complete the procedure listed in After working inside your system.

Related Links

- [Installing x8 SATA M.2 card](#)

Installing x8 SATA M.2 card

Prerequisites

- 1 Ensure that you read the Safety instructions.
- 2 Complete the procedure listed in Before working inside your system.

Steps

- 1 Align the holes on the SATA M.2 card with the holes on support bracket and slot cover.
- 2 Secure the support bracket and slot cover with screws.

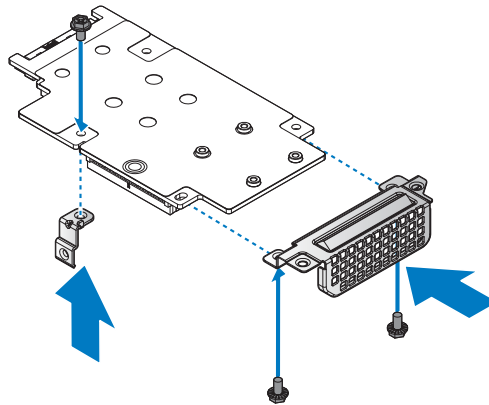

Figure 86. Installing the support bracket and slot cover

Table 59. Assembly material

Description	Quantity	Torque (lbs/inch)
#6-32 screw	3	6 ± 0.2

- 3 Flip over the SATA M.2 assembly.
- 4 Align the M.2 SSD board with the protrusion in the SATA M.2 card.
- 5 Insert the M.2 SSD until it is fully seated in the connector.
- 6 Lower the M.2 SSD board and hold it in place.
- 7 Secure the M.2 SSD board to the SATA M.2 card with the captive screw.

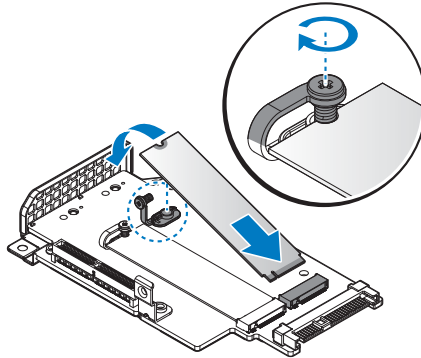

Figure 87. Installing the M.2 SSD board

- 8 Align the bridge board in the SATA M.2 card connector.
- 9 Install the bridge board.

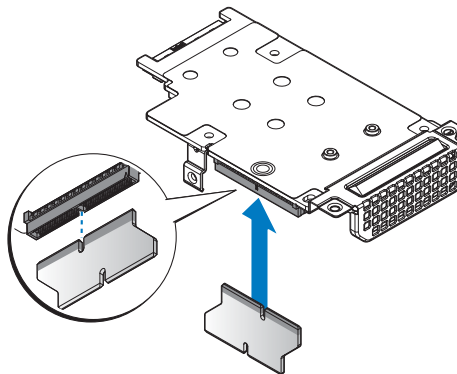

Figure 88. Installing the bridge board on the mezzanine card

- 10 Align the SATA M.2 assembly with the screw posts on the chassis and the connector on the server board.
- 11 Press the SATA M.2 assembly into the server board connector until it is fully seated.
- 12 Secure the SATA M.2 assembly with provided screws.

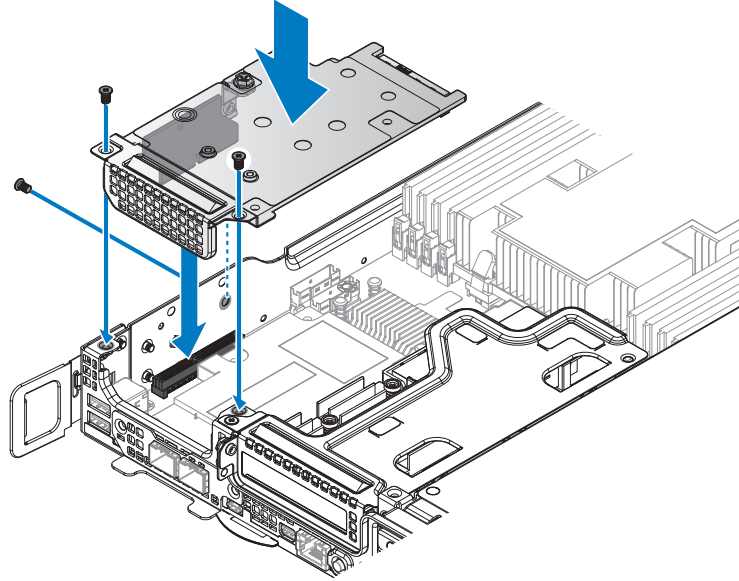

Figure 89. Installing the SATA M.2 assembly

Table 60. Assembly material

Description	Quantity	Torque (lbs/inch)
#6-32 screw	3	6 ± 0.2

Next steps

- 1 Complete the procedure listed in After working inside your system.

Removing x16 PCIe M.2 card

Prerequisites

- 1 Ensure that you read the Safety instructions.
- 2 Complete the procedure listed in Before working inside your system.

Steps

- 1 Loosen the captive screw securing the PCIe M.2 card.
- 2 Unlock the hook from the PCIe M.2 card and remove the PCIe M.2 card from the server board.

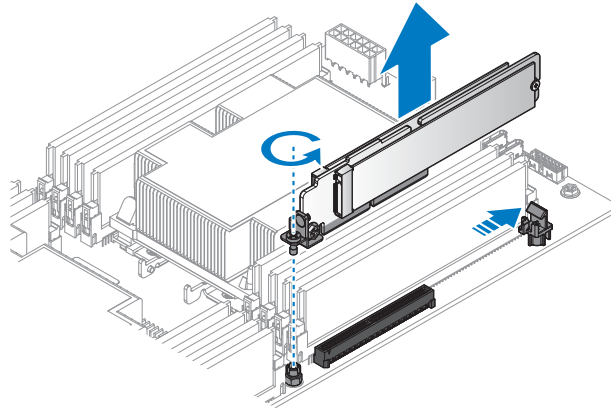

Figure 90. Removing the PCIe M.2 card

- 3 Remove the screw securing the PCIe M.2 card and M.2 SSD board.
- 4 Rotate the M.2 SSD board out and remove.

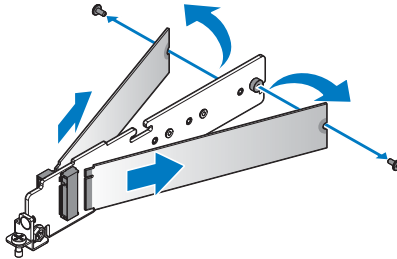

Figure 91. Removing the M.2 SSD board

- 5 Remove the securing screw from the PCIe M.2 card.
- 6 Remove the PCIe bracket from the PCIe M.2 card.

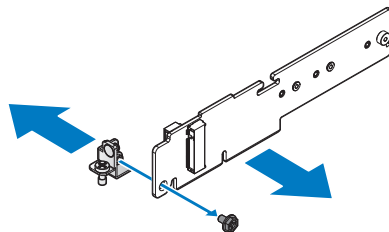

Figure 92. Removing the PCIe bracket

Next steps

- 1 Install the PCIe M.2 card.
- 2 Complete the procedure listed in After working inside your system.

Related Links

- Installing x16 PCIe M.2 card

Installing x16 PCIe M.2 card

Prerequisites

- 1 Ensure that you read the Safety instructions.
- 2 Complete the procedure listed in Before working inside your system.

Steps

- 1 Align the PCIe bracket with the PCIe M.2 card.
- 2 Secure the PCIe bracket with the provided screws.

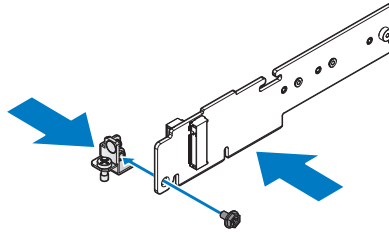

Figure 93. Installing the PCIe bracket

Table 61. Assembly material

Description	Quantity	Torque (lbs/inch)
M3 screw	1	6 ± 0.2

- 3 Align the M.2 SSD board with the protrusion in the PCIe M.2 card.
- 4 Insert the M.2 SSD until it is fully seated in the connector.
- 5 Lower the M.2 SSD board and hold it in place.
- 6 Insert the screws and tighten to secure.

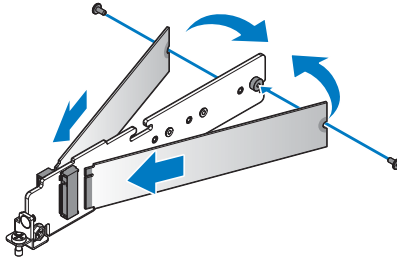

Figure 94. Installing the M.2 SSD board

Table 62. Assembly material

Description	Quantity	Torque (lbs/inch)
M2 x 4.5 mm	2	2.4~2.7

- 7 Align the PCIe M.2 card with the connector on the server board.
- 8 Press the PCIe M.2 card into the server board connector until it is fully seated. Make sure the hook is locked the PCIe M.2 card.
- 9 Tighten the captive screw on the PCIe bracket.

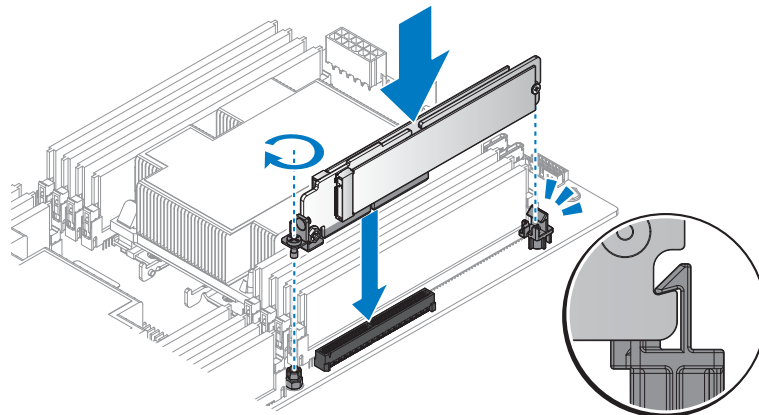

Figure 95. Installing the PCIe M.2 card

Next steps

- 1 Complete the procedure listed in After working inside your system.

Removing x16 SATA M.2 card

Prerequisites

- 1 Ensure that you read the Safety instructions.
- 2 Complete the procedure listed in Before working inside your system.

Steps

- 1 Loosen the captive screw securing the SATA M.2 card.
- 2 Unlock the hook from the SATA M.2 card and remove the SATA M.2 card from the server board.

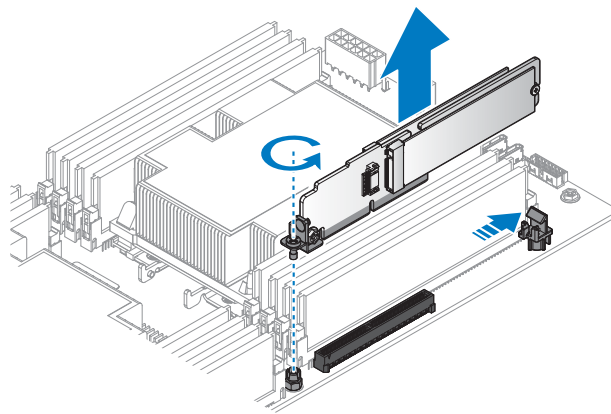

Figure 96. Removing the SATA M.2 card

- 3 Remove the screw securing the SATA M.2 card and M.2 SSD board.
- 4 Rotate the M.2 SSD board out and remove.

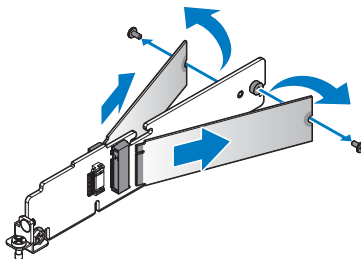

Figure 97. Removing the M.2 SSD board

- 5 Remove the securing screw from the SATA M.2 card.
- 6 Remove the PCIe bracket from the SATA M.2 card.

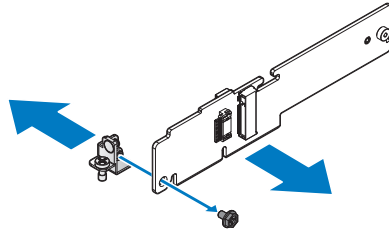

Figure 98. Removing the PCIe bracket

Next steps

- 1 Install the SATA M.2 card.
- 2 Complete the procedure listed in After working inside your system.

Related Links

- [Installing x16 SATA M.2 card](#)

Installing x16 SATA M.2 card

Prerequisites

- 1 Ensure that you read the Safety instructions.
- 2 Complete the procedure listed in Before working inside your system.

Steps

- 1 Align the PCIe bracket with the SATA M.2 card.
- 2 Secure the PCIe bracket with the provided screws.

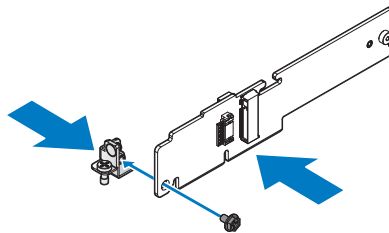

Figure 99. Installing the PCIe bracket

Table 63. Assembly material

Description	Quantity	Torque (lbs/inch)
M3 screw	1	6 ± 0.2

- 3 Align the M.2 SSD board with the protrusion in the SATA M.2 card.
- 4 Insert the M.2 SSD until it is fully seated in the connector.
- 5 Lower the M.2 SSD board and hold it in place.
- 6 Insert the screws and tighten to secure.

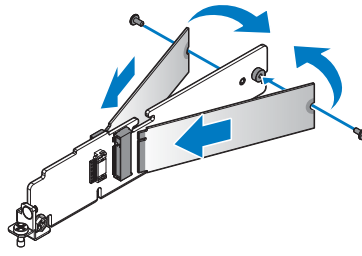

Figure 100. Installing the M.2 SSD board

Table 64. Assembly material

Description	Quantity	Torque (lbs/inch)
M2 x 4.5 mm	2	2.4~2.7

- 7 Align the SATA M.2 card with the connector on the server board.
- 8 Press the SATA M.2 card into the server board connector until it is fully seated. Make sure the hook is locked the SATA M.2 card.
- 9 Tighten the captive screw on the PCIe bracket.

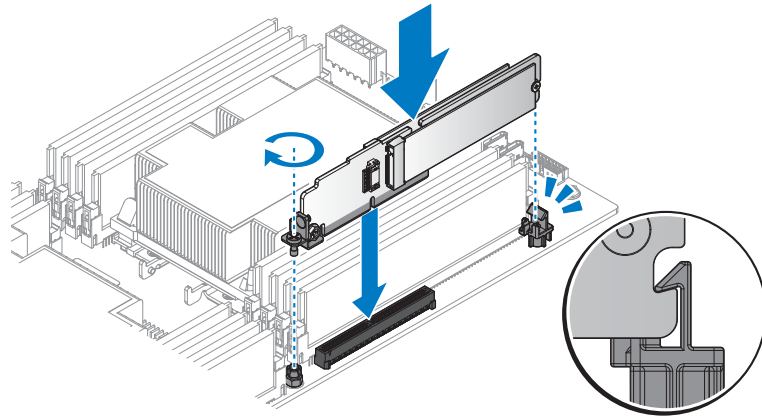

Figure 101. Installing the SATA M.2 card

Next steps

- 1 Complete the procedure listed in *After working inside your system*.

PCIe card

Removing PCIe card

Prerequisites

- 1 Follow the safety guidelines listed in the *Safety instructions* section.
- 2 Follow the procedure listed in the *Before working inside your system* section.

Steps

- 1 Remove the securing screws from the PCIe card assembly.
- 2 Remove the PCIe card assembly from the chassis.

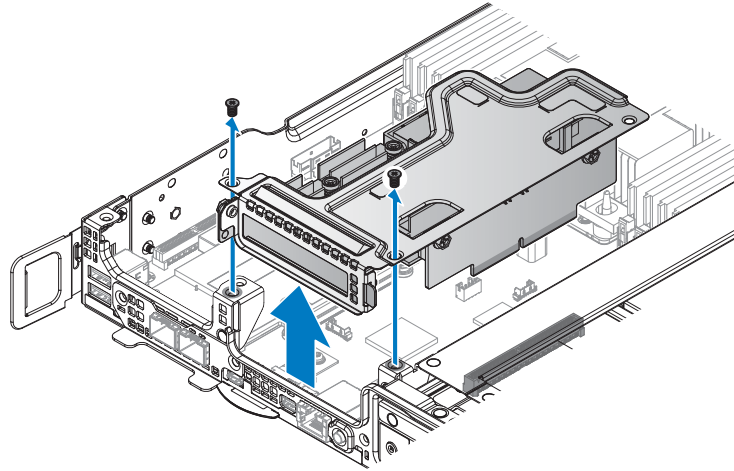



Figure 102. Removing the PCIe card assembly

- 3 Remove the securing screw from the PCIe card assembly.
- 4 Remove the PCIe card from the riser board.

 **NOTE:** You must install an expansion card filler cover over an empty expansion slot to maintain Federal Communications Commission (FCC) certification of the system. The covers also keep dust and dirt out of the system and aid in proper cooling and airflow inside the system.

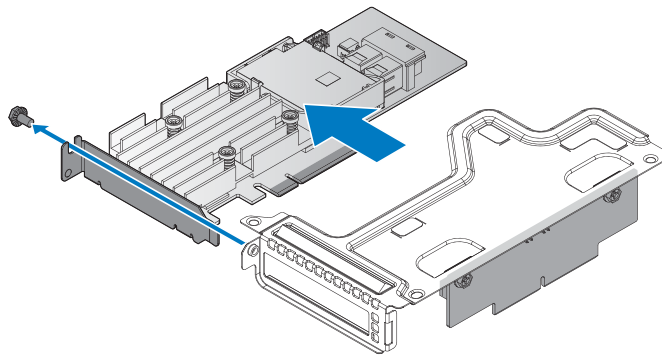

Figure 103. Removing the PCIe card

- 5 Remove the securing screws from the riser board.
- 6 Remove the riser board from the riser bracket.

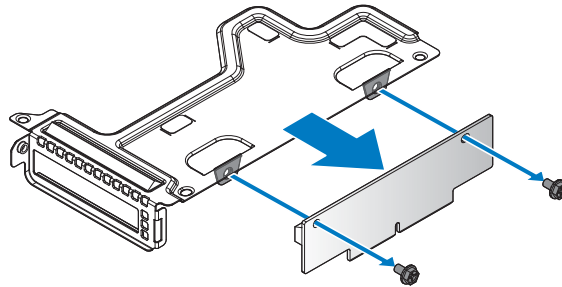

Figure 104. Removing the riser board

Next steps

- 1 Install the PCIe card.
- 2 Complete the procedure listed in *After working inside your system*.
- 3 Install any device drivers needed for the card as described in the documentation for the card.

Related Links

- [Installing PCIe card](#)

Installing PCIe card

Prerequisites

- 1 Follow the procedure listed in the *After working inside your system*.
- 2 Complete the procedure listed in *Before working inside your system*.

Steps

- 1 Remove the screws securing the riser bracket.
- 2 Remove the riser bracket from the chassis.

 **NOTE:** The PCIe bracket is customized for this system. Retain the bracket if replacing a new PCIe card for use with the new PCIe card.

- 3 Align the holes on riser board with the holes on riser bracket.
- 4 Secure the riser board with screws.

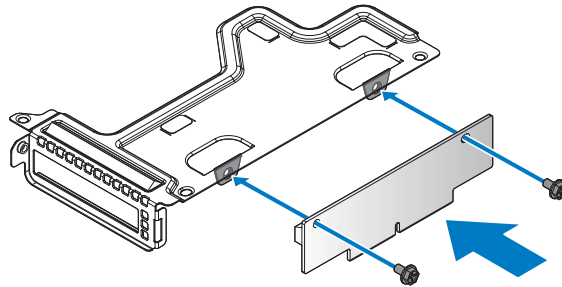

Figure 105. Installing the riser board on a bracket

Table 65. Assembly material

Description	Quantity	Torque (lbs/inch)
#6-32 screw	2	6 ± 0.2

- 5 Align the PCIe card with the riser bracket and the riser board connector.
- 6 Insert the PCIe card in the connector on the riser board.
- 7 Secure the PCIe card with the provided screw.

NOTE: You must install an expansion card filler cover over an empty expansion slot to maintain Federal Communications Commission (FCC) certification of the system. The covers also keep dust and dirt out of the system and aid in proper cooling and airflow inside the system.

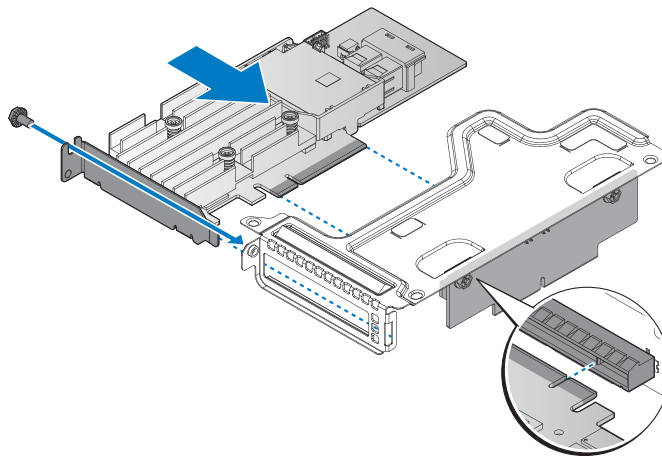

Figure 106. Installing the PCIe card in a bracket

Table 66. Assembly material

Description	Quantity	Torque (lbs/inch)
#6-32 screw	1	6 ± 0.2

- 8 Align the PCIe card assembly with the screw posts on the chassis and the connector on the server board.
- 9 Press the PCIe card assembly into the server board connector until it is fully seated.
- 10 Secure the PCIe card assembly with the provided screws.

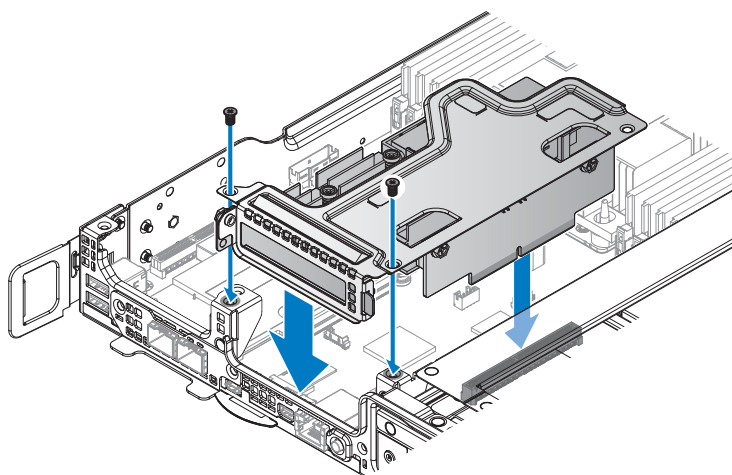

Figure 107. Installing the PCIe card assembly

Table 67. Assembly material

Description	Quantity	Torque (lbs/inch)
#6-32 screw	2	6 ± 0.2

Next steps

- 1 Follow the procedure listed in the After working inside your system.
- 2 Install any device drivers needed for the card as described in the documentation for the card.

OCP card

Removing OCP card from slot 1

Prerequisites

- 1 Ensure that you read the Safety instructions.
- 2 Complete the procedure listed in Before working inside your system.

Steps

- 1 Remove the securing screws from the OCP card assembly.
- 2 Remove the OCP card assembly from the chassis.

 **NOTE:** You must install an expansion card filler cover over an empty expansion slot to maintain Federal Communications Commission (FCC) certification of the system. The covers also keep dust and dirt out of the system and aid in proper cooling and airflow inside the system.

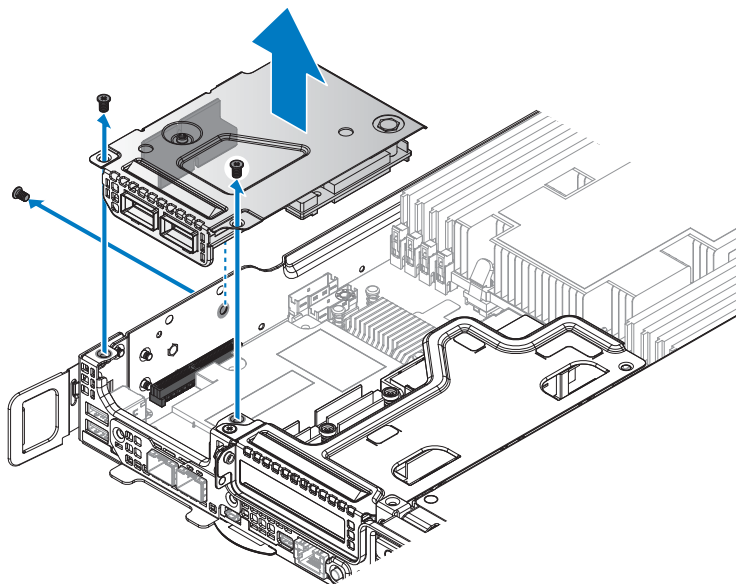

Figure 108. Removing the OCP card assembly

- 3 Remove the bridge board from the OCP card assembly.

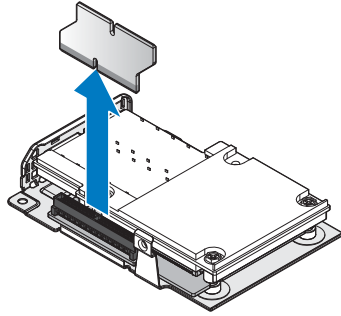

Figure 109. Removing the bridge board from the OCP assembly

- 4 Remove the securing screws from the OCP card.
- 5 Grasp the rearside of the OCP card and lift it up to clear the connector on the transfer board. Do not remove it completely.
- 6 Slide the OCP card out to allow the ports on the OCP card to clear the bracket.
- 7 Remove the OCP card.

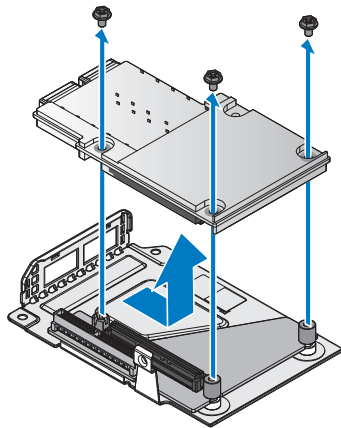

Figure 110. Removing the OCP card

- 8 Remove the securing standoff screw from the transfer board.
- 9 Slide the transfer board to release it from the securing pin on the OCP bracket and remove it.

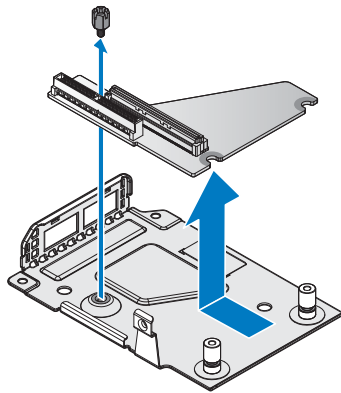

Figure 111. Removing the transfer board

Next steps

- 1 Install the OCP card into slot 1.
- 2 Complete the procedure listed in *After working inside your system*.

Related Links

- [Installing OCP card into slot 1](#)

Installing OCP card into slot 1

Prerequisites

- 1 Ensure that you read the *Safety instructions*.
- 2 Complete the procedure listed in *Before working inside your system*.

Steps

- 1 Align the slits on the transfer board with the securing pins on the OCP bracket.
- 2 Slide the transfer board into the pins until the securing holes on the transfer board and OCP bracket align.
- 3 Secure the transfer board with a standoff screw.

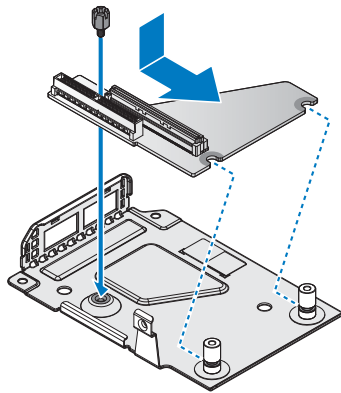

Figure 112. Installing the transfer board

Table 68. Assembly material

Description	Quantity	Torque (lbs/inch)
#6-32 screw	1	6 ± 0.2

- 4 Angle the OCP card over the OCP bracket and insert the ports in the slots on the bracket.
- 5 Align the connectors on the OCP card with the slot on the transfer board and lower the OCP card in place. Gently press it in place to seat it correctly.
- 6 Secure the OCP card with screws.

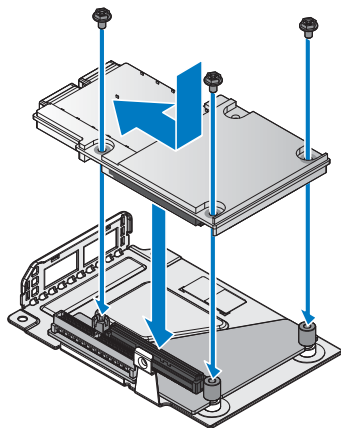

Figure 113. Installing the OCP card

Table 69. Assembly material

Description	Quantity	Torque (lbs/inch)
#6-32 screw	3	6 ± 0.2

- 7 Align the bridge board with the transfer board connector.
- 8 Install the bridge board.

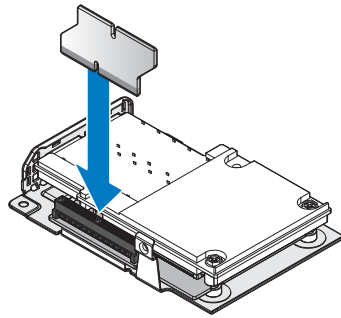

Figure 114. Installing the bridge board on the transfer board

- 9 Turn the OCP card assembly over and align it with the screw posts on the chassis and the connector on the server board.
- 10 Press the OCP card assembly into the server board connector until it is fully seated.
- 11 Secure the OCP card assembly with provided screws.

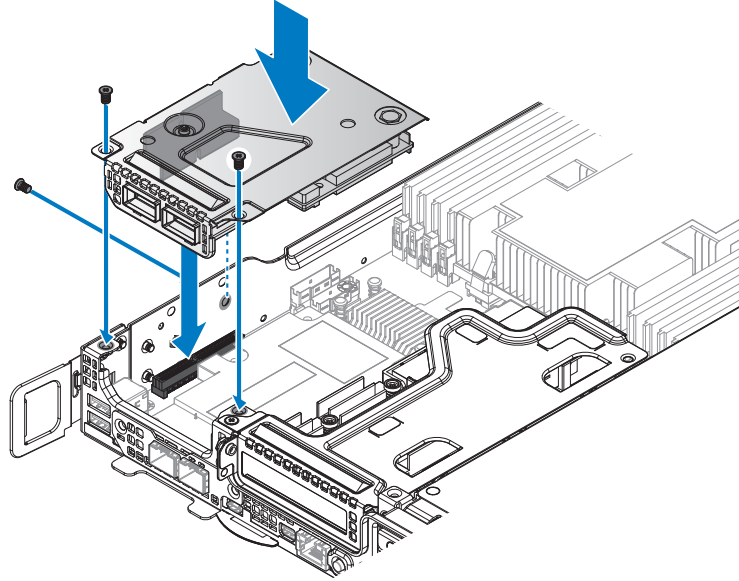

Figure 115. Installing the OCP card assembly

Table 70. Assembly material

Description	Quantity	Torque (lbs/inch)
#6-32 screw	3	6 ± 0.2

Next steps

- 1 Complete the procedure listed in After working inside your system.

Removing OCP card from slot 3

Prerequisites

- 1 Ensure that you read the Safety instructions.
- 2 Complete the procedure listed in Before working inside your system.
- 3 Remove the mezzanine card.

Steps

- 1 Remove the securing screws from the slot cover.
- 2 Remove the slot cover.

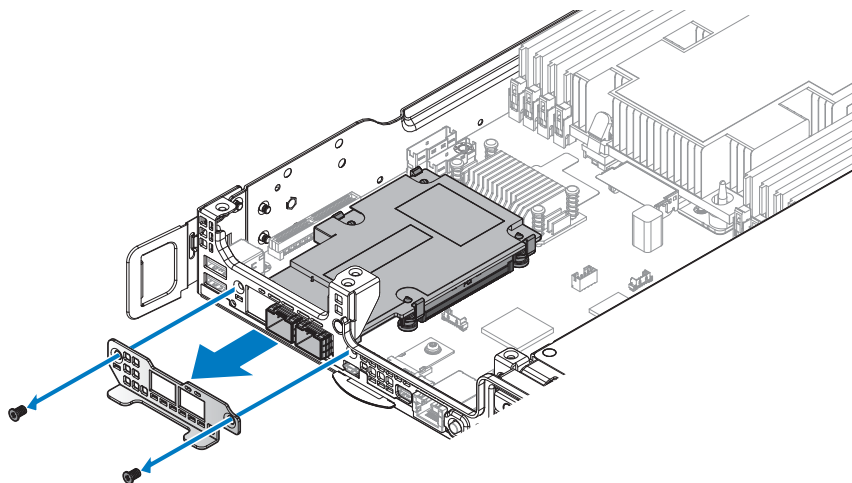

Figure 116. Removing the slot cover

- 3** Release the hooks locked on the OCP card.
- 4** Grasp the back of the OCP card and tilt upward. Do not lift the back of the OCP card completely to prevent damage to the components and I/O ports on the front.
- 5** Pull the OCP card back to release the I/O ports from the chassis, and lift the OCP card out to remove.

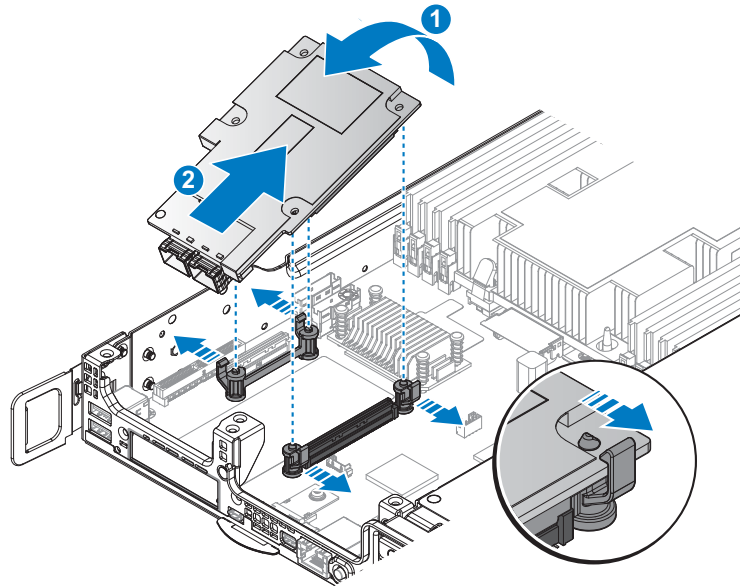

Figure 117. Removing the OCP card

Next steps

- 1 Install the OCP card.
- 2 Install the mezzanine card.
- 3 Complete the procedure listed in After working inside your system.

Related Links

- [Removing expansion card from slot 1](#)
- [Installing expansion card into slot 1](#)
- [Installing OCP card into slot 3](#)

Installing OCP card into slot 3

Prerequisites

- 1 Ensure that you read the Safety instructions.
- 2 Complete the procedure listed in Before working inside your system.

Steps

- 1 Align the I/O ports on the OCP card with the front of the server.

- 2 Angle the OCP card into the I/O ports. Make sure the ports on the OCP card are seated correctly in the chassis.
- 3 Gently lower the OCP card and press the OCP card into the server board connector until it is fully seated.

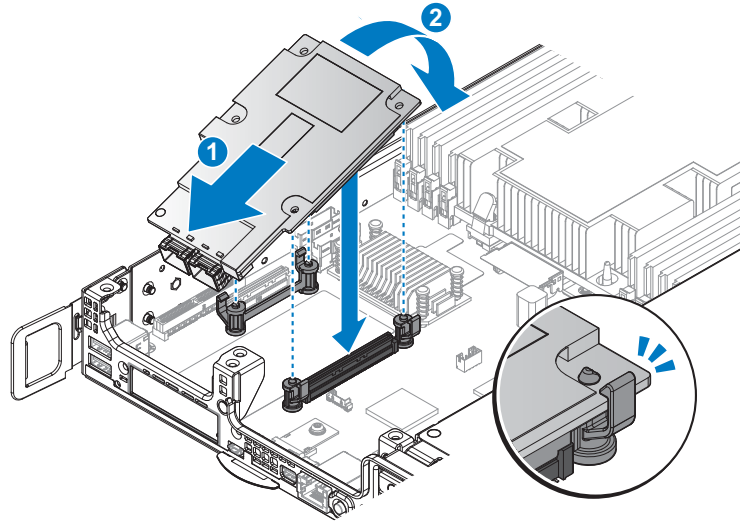

Figure 118. Installing the OCP card

- 4 Align the slot cover with the chassis.
- 5 Secure the slot cover with the provided screws.

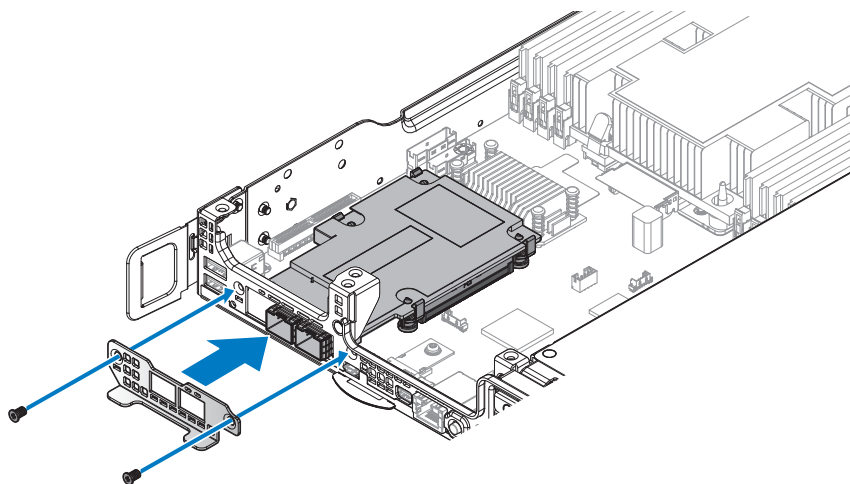

Figure 119. Installing the slot cover

Table 71. Assembly material

Description	Quantity	Torque (lbs/inch)
#6-32 screw	2	6 ± 0.2

Next steps

- 1 Install the mezzanine card.
- 2 Complete the procedure listed in After working inside your system.

Related Links

- Installing expansion card into slot 1

3M riser card

Removing 3M riser card

Prerequisites

- 1 Ensure that you read the Safety instructions.
- 2 Complete the procedure listed in Before working inside your system.
- 3 Remove the mezzanine card.

Steps

- 1 Remove the securing screws from the front 3M riser assembly.

- 2 Remove the front 3M riser assembly from the chassis.

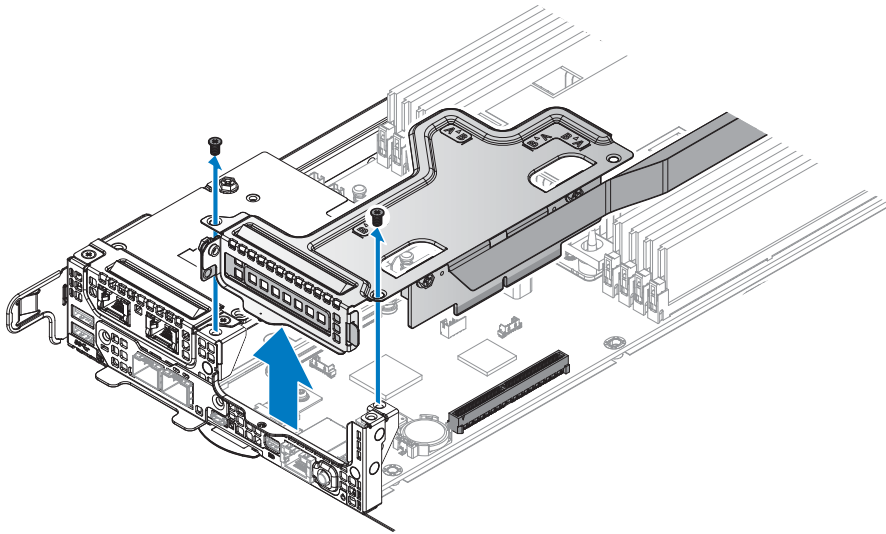

Figure 120. Removing the front 3M riser assembly

- 3 Remove the securing screws from the 3M riser card.
- 4 Remove the 3M riser card from the riser bracket.

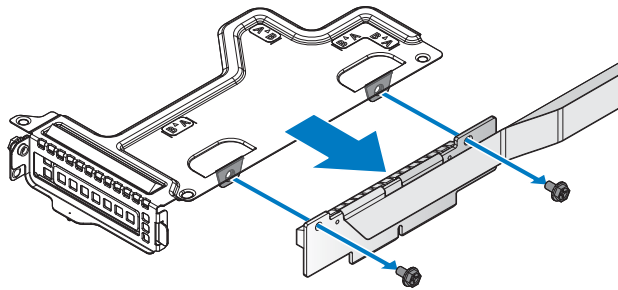

Figure 121. Removing the front 3M riser card

- 5 Loosen the captive screw securing the rear 3M riser card.
- 6 Unlock the hook from the rear 3M riser card and remove the rear 3M riser card from the server board.

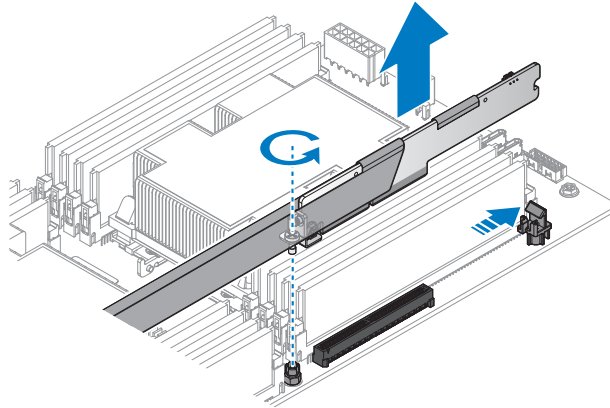

Figure 122. Removing the front 3M riser card

- 7 Remove the securing screws from the PCIe bracket.
- 8 Remove the rear 3M riser card from the PCIe bracket.

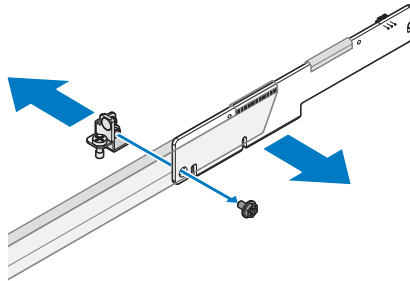

Figure 123. Removing the PCIe bracket

Next steps

- 1 Install the 3M riser card.
- 2 Complete the procedure listed in [After working inside your system](#).
- 3 Install any device drivers needed for the card as described in the documentation for the card.

Related Links

- [Installing 3M riser card](#)

Installing 3M riser card

Prerequisites

- 1 Ensure that you read the [Safety instructions](#).

- 2 Read and understand the cable routing plan in Cable routing overview.
- 3 Complete the procedure listed in Before working inside your system.

Cable routing overview

The following routing plan is available for the 3M riser card installation. To ensure correct cable position see Figure 124 for further details.

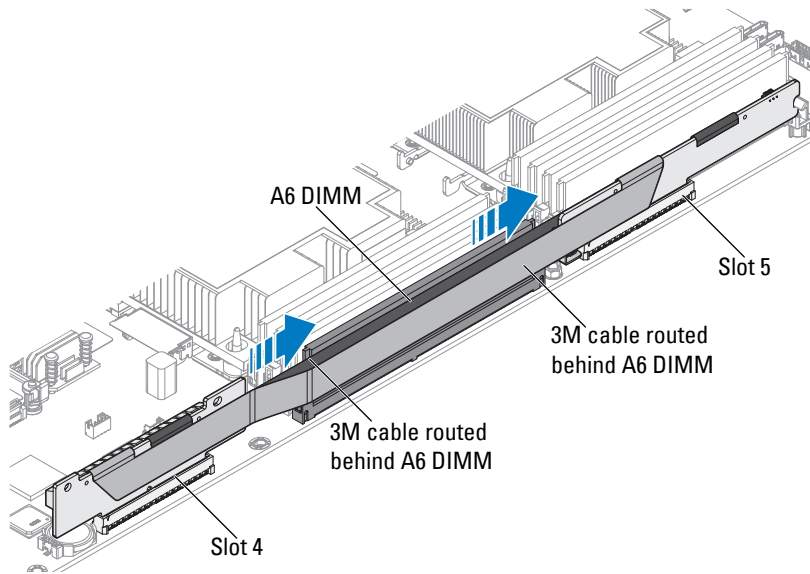



Figure 124. Cable routing overview

Steps

- 1 Remove the screws securing the riser bracket.
- 2 Remove the riser bracket from the chassis.

 **NOTE:** The PCIe bracket is customized for this system. Retain the bracket if replacing a new PCIe card for use with the new PCIe card.

- 3 Align the holes on riser board with the holes on riser bracket.
- 4 Secure the riser board with screws.

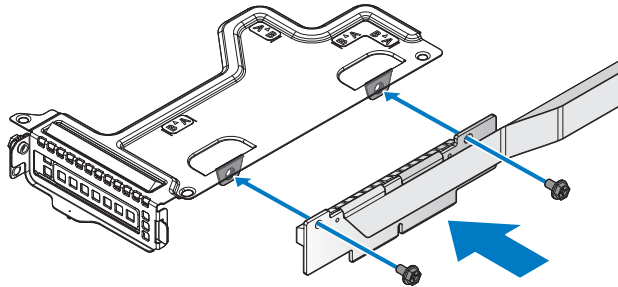

Figure 125. Installing the front 3M riser card on a bracket

Table 72. Assembly material

Description	Quantity	Torque (lbs/inch)
#6-32 screw	2	6 ± 0.2

- 5 Align the front 3M riser assembly with the screw posts on the chassis and the connector on the server board.
- 6 Press the front 3M riser assembly into the server board connector until it is fully seated.
- 7 Secure the front 3M riser assembly with the provided screws.

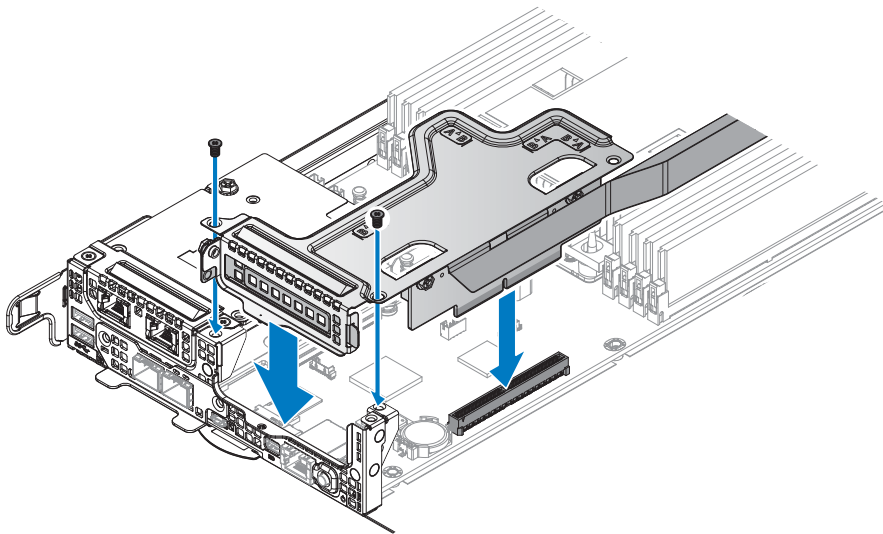

Figure 126. Installing the front 3M riser assembly

Table 73. Assembly material

Description	Quantity	Torque (lbs/inch)
#6-32 screw	2	6 ± 0.2

- 8 Align the PCIe bracket with the rear 3M riser card.
- 9 Secure the PCIe bracket with the provided screws.

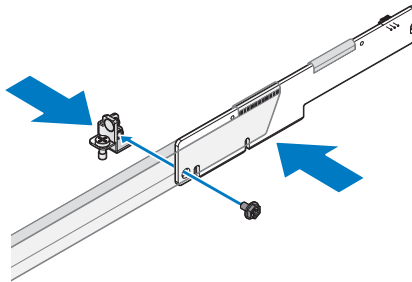

Figure 127. Installing the PCIe bracket

Table 74. Assembly material

Description	Quantity	Torque (lbs/inch)
M3 screw	1	6 ± 0.2

- 10 Align the rear 3M riser card with the connector on the server board.
- 11 Press the rear 3M riser card into the server board connector until it is fully seated. Make sure the hook is locked the rear 3M riser card.
- 12 Tighten the captive screw on the PCIe bracket.

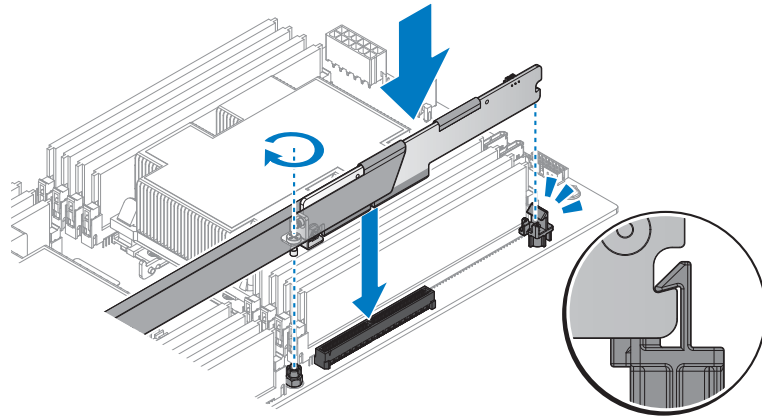

Figure 128. Installing the rear 3M riser card

Next steps

- 1 Follow the procedure listed in the After working inside your system.
- 2 Install any device drivers needed for the card as described in the documentation for the card.

NPIO card

Removing NPIO card from the rear bay

Prerequisites

⚠ CAUTION: Many repairs may only be done by a certified service technician. You should only perform troubleshooting and simple repairs as authorized in your product documentation, or as directed by the online or telephone service and support team. Damage due to servicing that is not authorized by Dell is not covered by your warranty. Read and follow the safety instructions that are shipped with your product.

- 1 Follow the safety guidelines listed in the Safety instructions section.
- 2 Follow the procedure listed in the Before working inside your system section.

Steps

- 1 Disconnect the cables from the NPIO card assembly.
- 2 Loosen the thumb screws.
- 3 Remove the NPIO card assembly from the chassis.

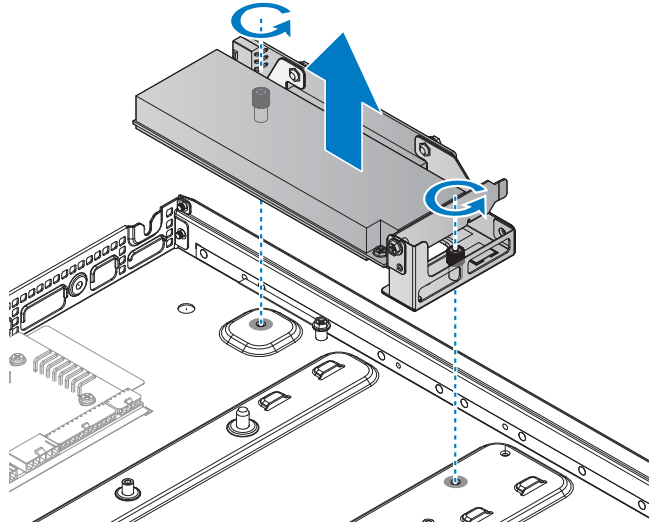

Figure 129. Removing the NPIO card assembly

- 4 Remove the securing screw from the NPIO card assembly.
- 5 Remove the NPIO card from the riser board.



NOTE: You must install an expansion card filler cover over an empty expansion slot to maintain Federal Communications Commission (FCC) certification of the system. The covers also keep dust and dirt out of the system and aid in proper cooling and airflow inside the system.

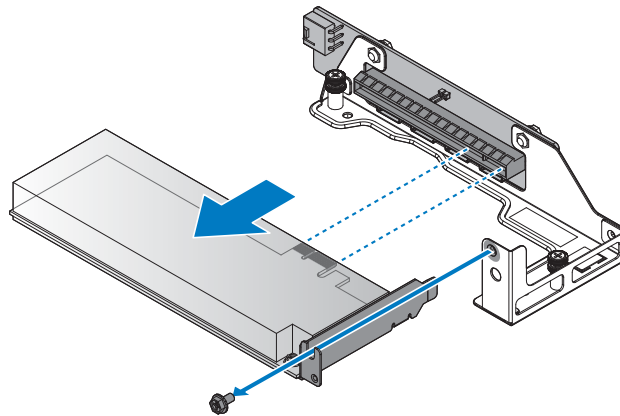

Figure 130. Removing the NPIO card

- 6 Remove the securing screws from the riser board.

- 7 Remove the riser board from the riser bracket.

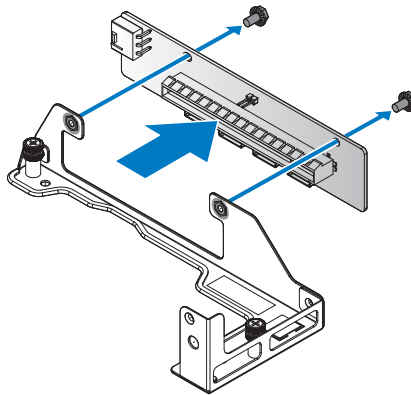

Figure 131. Removing the riser board

Next steps

- 1 Install the NPIO card.
- 2 Complete the procedure listed in *After working inside your system*.
- 3 Install any device drivers needed for the card as described in the documentation for the card.

Related Links

- [Installing NPIO card in the rear bay](#)

Installing NPIO card in the rear bay

Prerequisites

- 1 Follow the procedure listed in the *After working inside your system*.
- 2 Complete the procedure listed in *Before working inside your system*.

Steps

- 1 Remove the screws securing the riser bracket.
- 2 Remove the riser bracket from the chassis.



NOTE: The PCIe bracket is customized for this system. Retain the bracket if replacing a new PCIe card for use with the new PCIe card.

- 3 Align the holes on riser board with the holes on riser bracket.
- 4 Secure the riser board with screws.

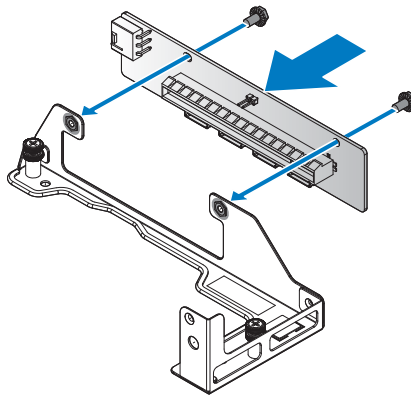

Figure 132. Installing the riser board on a bracket

Table 75. Assembly material

Description	Quantity	Torque (lbs/inch)
#6-32 screw	2	6 ± 0.2

- 5 Align the NPIO card with the riser bracket and the riser board connector.
- 6 Insert the NPIO card in the connector on the riser board.
- 7 Secure the NPIO card with the provided screw.

NOTE: You must install an expansion card filler cover over an empty expansion slot to maintain Federal Communications Commission (FCC) certification of the system. The covers also keep dust and dirt out of the system and aid in proper cooling and airflow inside the system.

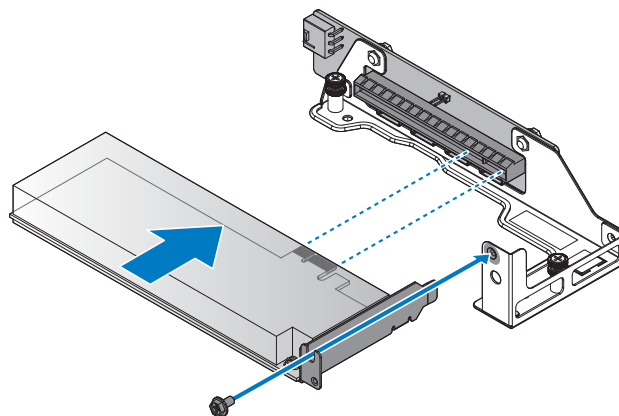

Figure 133. Installing the NPIO card in a bracket

Table 76. Assembly material

Description	Quantity	Torque (lbs/inch)
#6-32 screw	1	6 ± 0.2

- 8 Align the NPIO card assembly with the screw posts on the chassis and the connector on the server board.
- 9 Press the NPIO card assembly into the server board connector until it is fully seated.
- 10 Secure the NPIO card assembly with the provided screws.

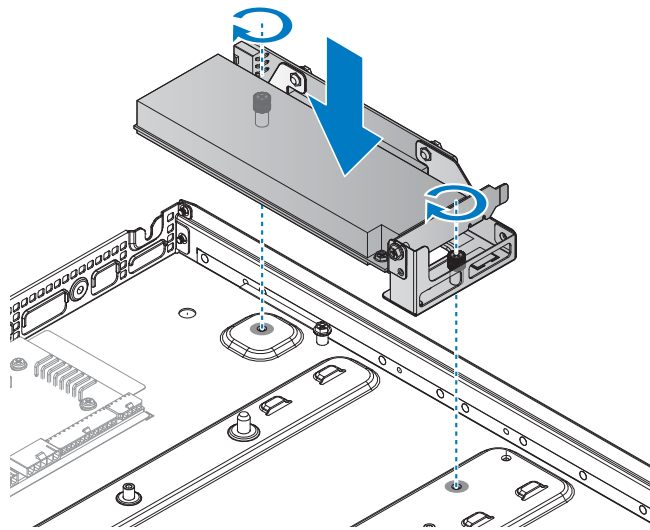

Figure 134. Installing the NPIO card assembly

Table 77. Assembly material

Description	Quantity	Torque (lbs/inch)
#6-32 screw	2	6 ± 0.2

- 11 Connect the cables to the NPIO card assembly.

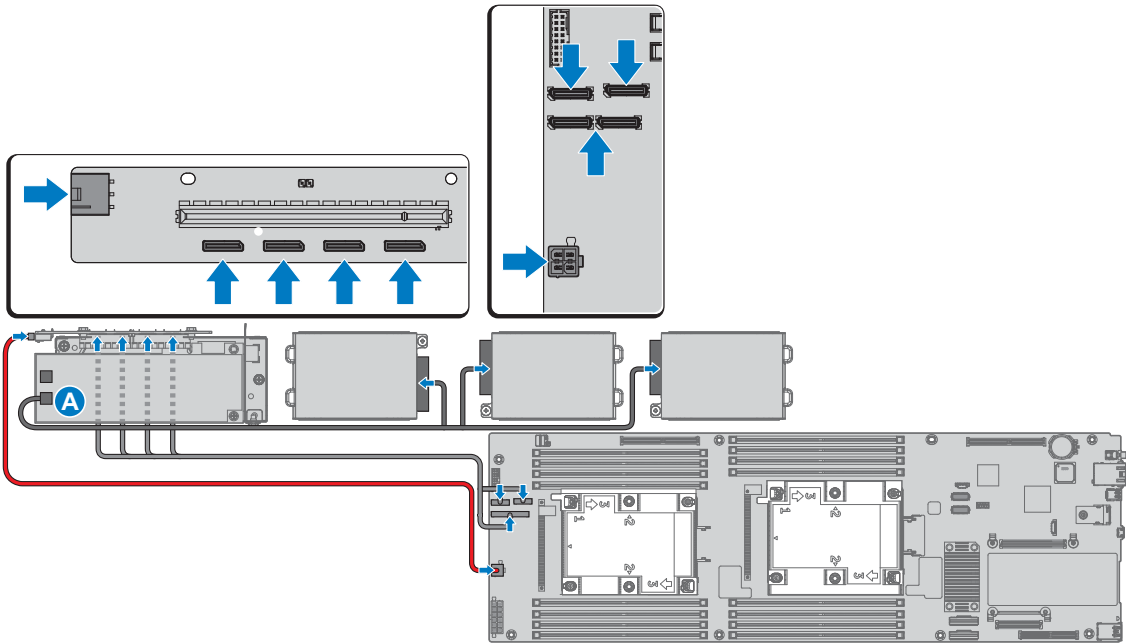

Figure 135. Connecting the cables

Next steps

- 1 Follow the procedure listed in the After working inside your system.
- 2 Install any device drivers needed for the card as described in the documentation for the card.

Removing NPIO card from hot swappable bay

Prerequisites

⚠ CAUTION: Many repairs may only be done by a certified service technician. You should only perform troubleshooting and simple repairs as authorized in your product documentation, or as directed by the online or telephone service and support team. Damage due to servicing that is not authorized by Dell is not covered by your warranty. Read and follow the safety instructions that are shipped with your product.

- 1 Follow the safety guidelines listed in the Safety instructions section.
- 2 Follow the procedure listed in the Before working inside your system section.

Steps

- 1 Disconnect the cables from the NPIO card assembly.
- 2 Remove the securing screws from the NPIO card assembly.

- 3 Remove the NPIO card assembly from the chassis.

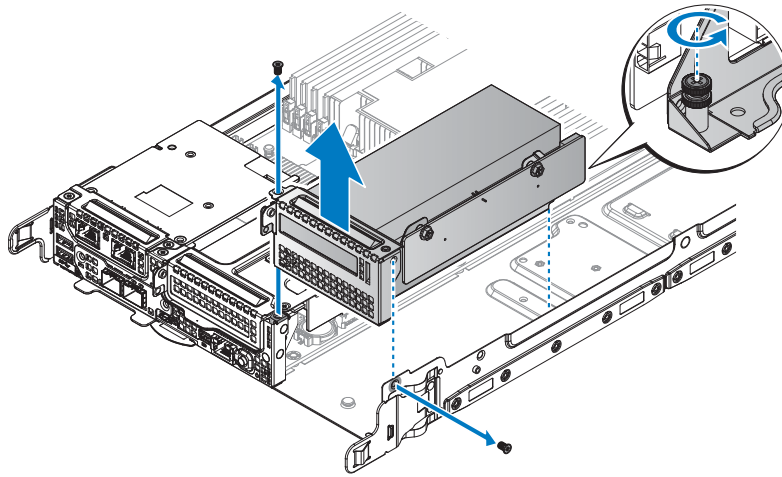

Figure 136. Removing the NPIO card assembly

- 4 Remove the securing screw from the NPIO card assembly.
- 5 Remove the NPIO card from the riser board.

NOTE: You must install an expansion card filler cover over an empty expansion slot to maintain Federal Communications Commission (FCC) certification of the system. The covers also keep dust and dirt out of the system and aid in proper cooling and airflow inside the system.

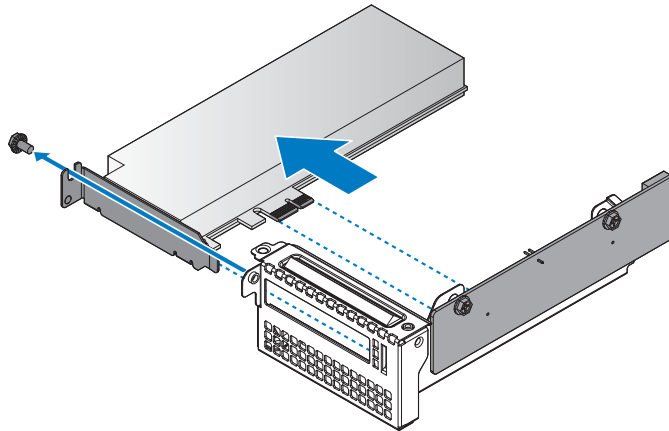

Figure 137. Removing the NPIO card

- 6 Remove the securing screws from the riser board.

- 7 Remove the riser board from the riser bracket.

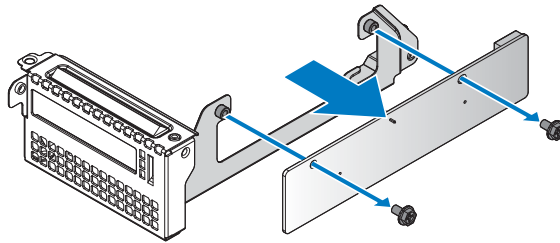

Figure 138. Removing the riser board

Next steps

- 1 Install the NPIO card into hot swappable bay.
- 2 Complete the procedure listed in After working inside your system.
- 3 Install any device drivers needed for the card as described in the documentation for the card.

Related Links

- [Installing NPIO card in hot swappable bay](#)

Installing NPIO card in hot swappable bay

Prerequisites

- 1 Follow the procedure listed in the After working inside your system.
- 2 Complete the procedure listed in Before working inside your system.

Steps

- 1 Remove the screws securing the riser bracket.
- 2 Remove the riser bracket from the chassis.



NOTE: The PCIe bracket is customized for this system. Retain the bracket if replacing a new PCIe card for use with the new PCIe card.

- 3 Align the holes on riser board with the holes on riser bracket.
- 4 Secure the riser board with screws.

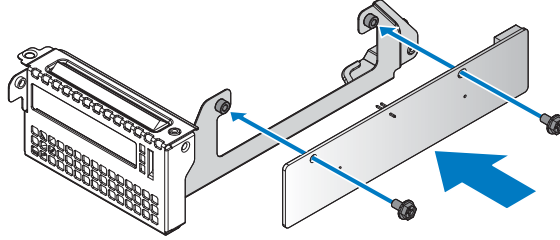

Figure 139. Installing the riser board on a bracket

Table 78. Assembly material

Description	Quantity	Torque (lbs/inch)
#6-32 screw	2	6 ± 0.2

- 5 Align the NPIO card with the riser bracket and the riser board connector.
- 6 Insert the NPIO card in the connector on the riser board.
- 7 Secure the NPIO card with the provided screw.

NOTE: You must install an expansion card filler cover over an empty expansion slot to maintain Federal Communications Commission (FCC) certification of the system. The covers also keep dust and dirt out of the system and aid in proper cooling and airflow inside the system.

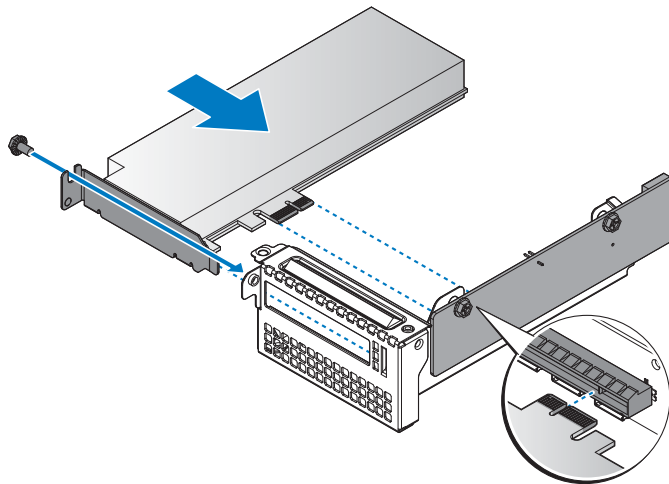

Figure 140. Installing the NPIO card in a bracket

Table 79. Assembly material

Description	Quantity	Torque (lbs/inch)
#6-32 screw	1	6 ± 0.2

- 8 Align the NPIO card assembly with the screw posts on the chassis and the connector on the server board.
- 9 Press the NPIO card assembly into the server board connector until it is fully seated.
- 10 Secure the NPIO card assembly with the provided screws.

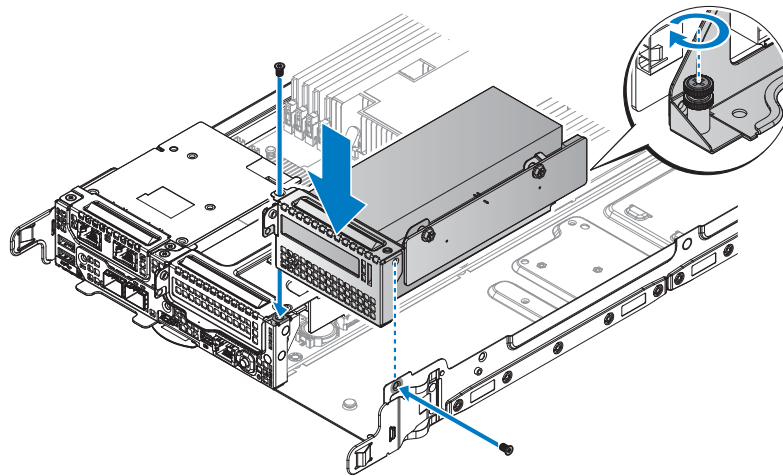

Figure 141. Installing the NPIO card assembly

Table 80. Assembly material

Description	Quantity	Torque (lbs/inch)
#6-32 screw	2	6 ± 0.2

- 11 Connect the cables to the NPIO card assembly.

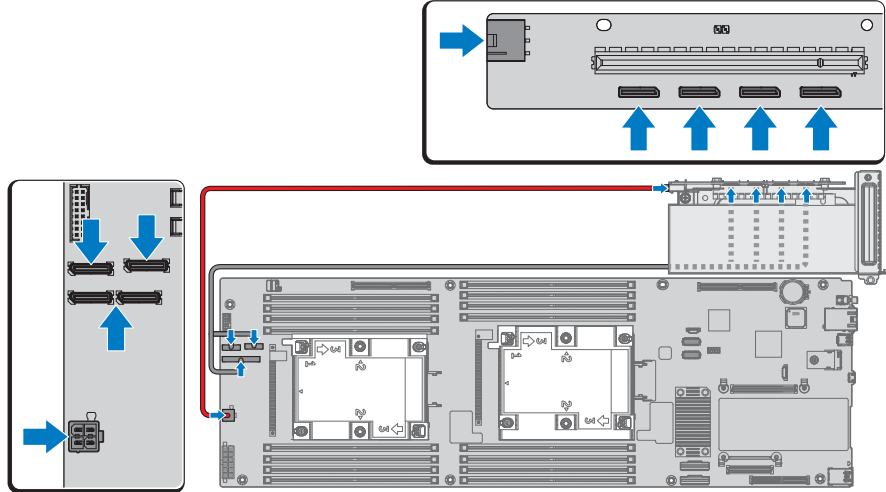

Figure 142. Connecting the cables

Next steps

- 1 Follow the procedure listed in the After working inside your system.
- 2 Install any device drivers needed for the card as described in the documentation for the card.

NVMe riser

Removing NVMe riser

Prerequisites

- 1 Ensure that you read the Safety instructions.
- 2 Complete the procedure listed in Before working inside your system.

Steps

- 1 Loosen the captive screw securing the NVMe riser.
- 2 Unlock the hook from the NVMe riser and remove the NVMe riser from the server board.

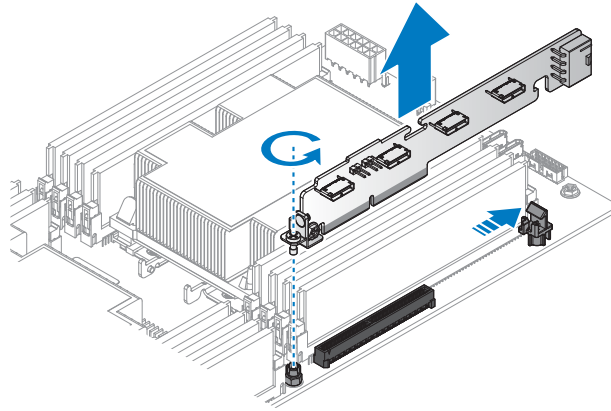

Figure 143. Removing the NVMe riser

- 3 Remove the securing screw from the NVMe riser.
- 4 Remove the PCIe bracket from the NVMe riser.

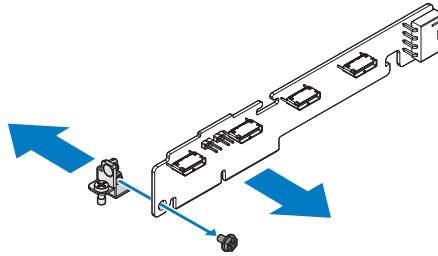

Figure 144. Removing the PCIe bracket

Next steps

- 1 Install the NVMe riser.
- 2 Complete the procedure listed in After working inside your system.

Related Links

- [Installing NVMe riser](#)

Installing NVMe riser

Prerequisites

- 1 Ensure that you read the Safety instructions.
- 2 Complete the procedure listed in Before working inside your system.

Steps

- 1 Align the PCIe bracket with the NVMe riser.
- 2 Secure the PCIe bracket with the provided screws.

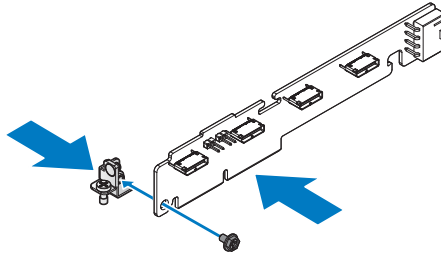

Figure 145. Installing the PCIe bracket

Table 81. Assembly material

Description	Quantity	Torque (lbs/inch)
M3 screw	1	6 ± 0.2

- 3 Align the NVMe riser with the connector on the server board.
- 4 Press the NVMe riser into the server board connector until it is fully seated. Make sure the hook is locked the NVMe riser.
- 5 Tighten the captive screw on the PCIe bracket.

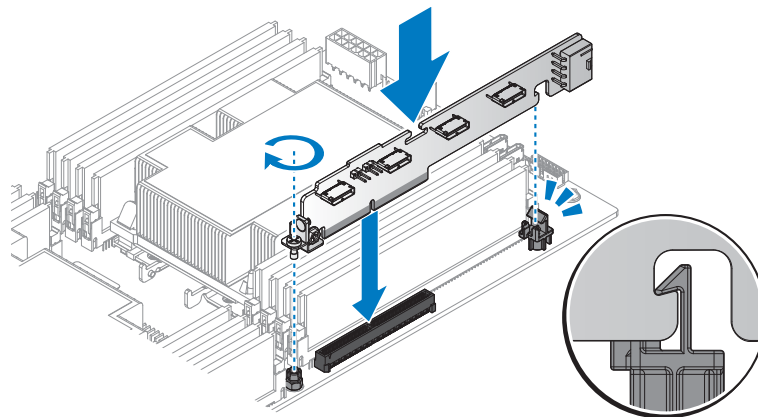

Figure 146. Installing the NVMe riser

Next steps

- 1 Complete the procedure listed in After working inside your system.

NPDB

Removing NPDB

Prerequisites

- 1 Ensure that you read the Safety instructions.
- 2 Complete the procedure listed in Before working inside your system.

Steps

- 1 Disconnect all cables from the NPDB.
- 2 Remove the securing screw from the NPDB.
- 3 Lift the NPDB to remove from the chassis.

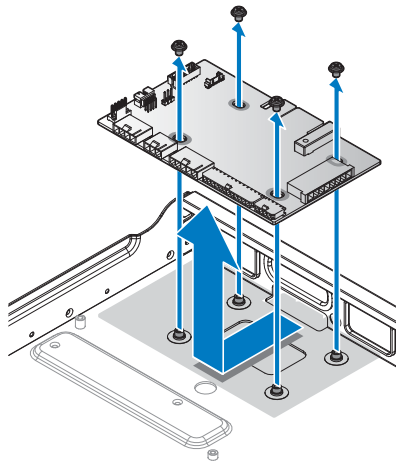

Figure 147. Removing the NPDB

Next steps

- 1 Install the NPDB.
- 2 Complete the procedure listed in After working inside your system.

Related Links

- [Installing NPDB](#)

Installing NPDB

Prerequisites

Ensure that you read the Safety instructions.

Steps

- 1 Align the screw holes on the NPDB to the screw posts on the chassis.
- 2 Lower the NPDB in place.
- 3 Secure the NPDB with the screws.

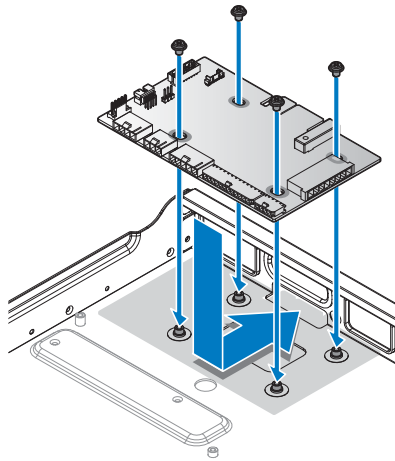

Figure 148. Installing the NPDB

Table 82. Assembly material

Description	Quantity	Torque (lbs/inch)
#6-32 screw	4	6 ± 0.2

- 4 Connect all cables from the server to the NPDB.

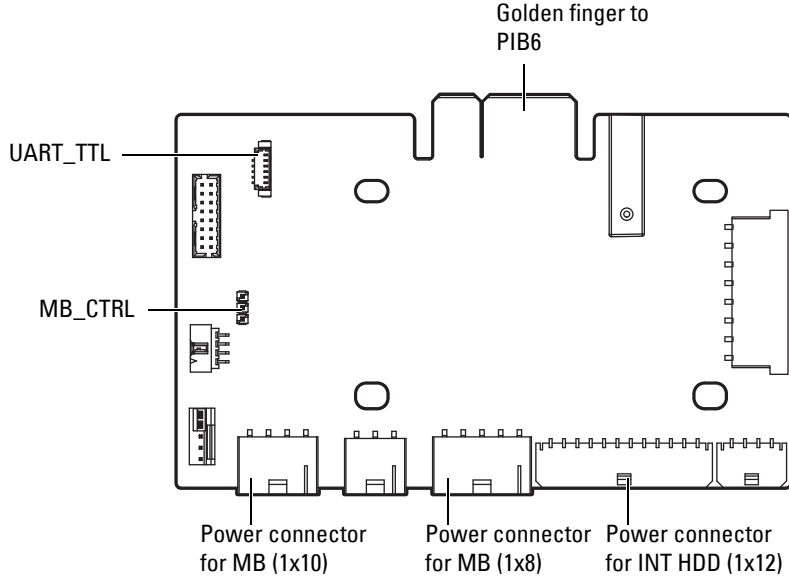

Figure 149. NPDB overview

Next steps

- 1 Complete the procedure listed in After working inside your system.

Hard drive backplane

Removing HDD backplane

Prerequisites

NOTE: The procedure is available only for DSS 9620 server with 2.5-inch hot swappable HDDs.

- 1 Ensure that you read the Safety instructions.
- 2 Complete the procedure listed in Before working inside your system.
- 3 Remove the 2.5-inch hot swappable HDDs.

Steps

- 1 Disconnect the power cabling and miniSAS cable from the HDD backplane.
- 2 Remove the securing screw from the HDD backplane.
- 3 Lift up the HDD backplane to remove from the chassis.

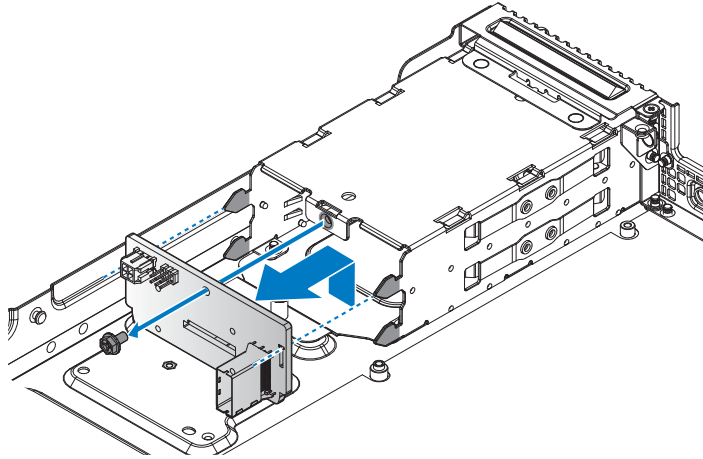

Figure 150. Removing the HDD backplane

Next steps

- 1 Install the HDD backplane.
- 2 Complete the procedure listed in After working inside your system.

Related Links

- [Removing hot swappable hard drive](#)
- [Installing HDD backplane](#)

Installing HDD backplane

Prerequisites

 **NOTE:** The procedure is available only for DSS 9620 server with 2.5-inch hot swappable HDDs.

- 1 Ensure that you read the Safety instructions.
- 2 Complete the procedure listed in Before working inside your system.

Steps

- 1 Align the HDD backplane to the HDD cage in the chassis.
- 2 Install the HDD backplane.
- 3 Secure the HDD backplane with the provided screw.
- 4 Connect the power cabling and miniSAS cable to the HDD backplane.

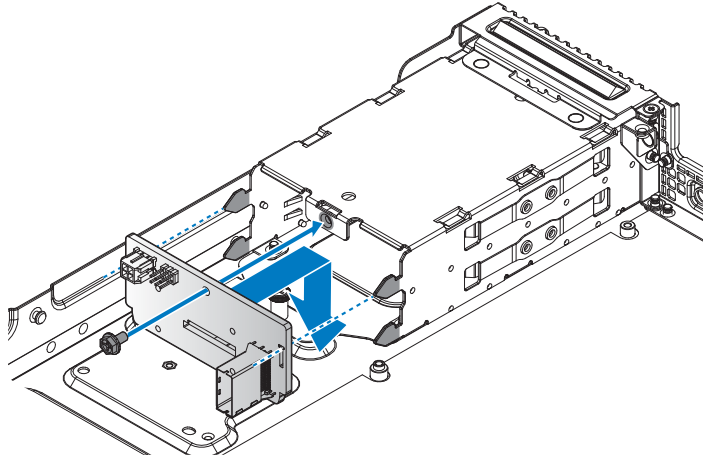

Figure 151. Installing the HDD backplane

Table 83. Assembly material

Description	Quantity	Torque (lbs/inch)
#6-32 screw	1	6 ± 0.2

Next steps

- 1 Install the 2.5-inch hot swappable HDDs.
- 2 Complete the procedure listed in After working inside your system.

Related Links

- [Installing hot swappable hard drive](#)

Using system diagnostics

If you experience a problem with your system, run the system diagnostics before contacting Dell for technical assistance. The purpose of running system diagnostics is to test your system hardware without using additional equipment or risking data loss. If you are unable to fix the problem yourself, service and support personnel can use the diagnostics results to help you solve the problem.

Dell Embedded System Diagnostics



NOTE: The Dell Embedded System Diagnostics is also known as Enhanced Pre-boot System Assessment (ePSA) diagnostics.

The Embedded System Diagnostics provides a set of options for particular device groups or devices allowing you to:

- Run tests automatically or in an interactive mode
- Repeat tests
- Display or save test results
- Run thorough tests to introduce additional test options to provide extra information about the failed device(s)
- View status messages that inform you if tests are completed successfully
- View error messages that inform you of problems encountered during testing

Running the Embedded System Diagnostics from Boot Manager

Prerequisites

Run the Embedded System Diagnostics (ePSA) if your system does not boot.

Steps

- 1 When the system is booting, press F10.
- 2 Use the up arrow and down arrow keys to select **System Utilities > Launch Diagnostics**.

The ePSA Pre-boot System Assessment window is displayed, listing all devices detected in the system. The diagnostics starts executing the tests on all the detected devices.

Running Embedded System Diagnostics from Lifecycle Controller

1 As the system boots, press F10.

2 Select **Hardware Diagnostics > Run Hardware Diagnostics**.

The **ePSA Pre-boot System Assessment** window is displayed, listing all devices detected in the system. The diagnostics starts executing the tests on all the detected devices.

System diagnostic controls

Table 84. System diagnostic controls

Menu	Description
Configuration	Displays the configuration and status information of all detected devices.
Results	Displays the results of all tests that are run.
System health	Provides the current overview of the system performance.
Event log	Displays a time-stamped log of the results of all tests run on the system. This is displayed if at least one event description is recorded.

Jumpers and connectors

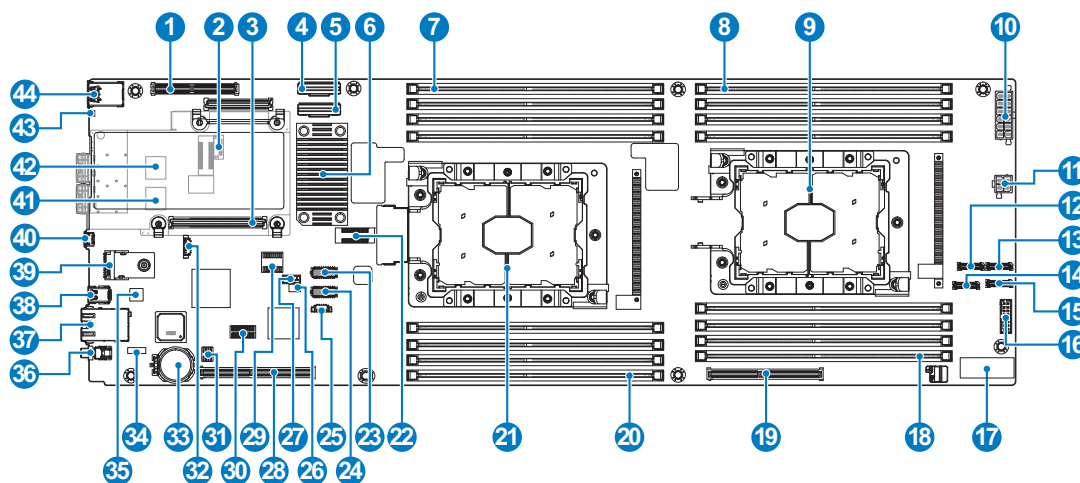

Figure 152. Jumpers and connectors

Table 85. Jumpers and connectors description

No.	Description	Location	No.	Description	Location
1	Mezzanine slot	J_DCS_MEZZ	23	CPU 1 HIF sideband connector	J_HFI1
2	Internal TTL COM port	J_BMC_COM2	24	CPU 2 HIF sideband connector	J_HFI2
3	OCP A + B connector	J_OCP_A, J_OCP_B	25	PMBUS connector	J_PMBUS
4	SATA x8 connector	SATA1	26	CPLD JTAG connector	J_CPLD_JTAG
5	SATA x6 connector	SATA2	27	Internal USB connector	INTERNAL_USB1
6	Lewisburg-2	U_LBG	28	PCIe x16 main riser connector	J_PCIE_RISER
7	DIMM slot CPU 1		29	BIOS socket	U_SPI_BIOS_SKT
8	DIMM slot CPU 2		30	SPIVU debug connector	J_SPIVU1

Table 85. Jumpers and connectors description (continued)

No.	Description	Location	No.	Description	Location
9	CPU 2	J_CPU2_A, J_CPU2_B	31	iDRAC uboot SPI socket	U_BMC_SPI_SKT
10	G5 power connector	J_G5_PWR	32	G5 LAN management connector	G5_MGMT
11	G5 HDD power connector	PWR_HDV1	33	Battery socket	BAT1
12	NVMe connector	J_NMVE_A2	34	Internal BMC UART connector	J_BMC_UART
13	NVMe connector	J_NMVE_A1	35	Intel i350 GbE LAN controller	U_LOM1
14	NVMe connector	J_NMVE_B2	36	Power button	SW1
15	NVMe connector	J_NMVE_B1	37	Shared RJ-45 connector	RJ45
16	G5 control connector	J_G5_CTRL	38	Mini DP connector	DP_PORT
17	Interposer connector	J_INTERPOSESR	39	TPM socket	TPM
18	DIMM slot CPU 2		40	iDRAC management USB	DEBUG_USB1
19	PCIe x16 buried riser connector	J_M2_RISER	41	SFP+ connector 2	SFP2
20	DIMM slot CPU 1		42	SFP+ connector 1	SFP1
21	CPU 1		43	UID LED	LED3
22	Merge XDP	MERGE_XDP	44	Dual USB 3.0 connector	J_USB3

Troubleshooting your system

Troubleshooting list

Table 86. Troubleshooting list

Issue description	Root cause	Troubleshooting step
KVM test failure	Incompatible brand: ATEN/cs1758	Suggested KVM types: <ul style="list-style-type: none">• ATEN/cs1308• ATEN/cs1732b

Getting help

Contacting Dell

Dell provides several online and telephone based support and service options. If you do not have an active internet connection, you can find contact information about your purchase invoice, packing slip, bill, or Dell product catalog. Availability varies by country and product, and some services may not be available in your area. To contact Dell for sales, technical assistance, or customer service issues:

- 1 Go to Dell.com/support.
- 2 Select your country from the drop-down menu on the lower right corner of the page.
- 3 For customized support:
 - a Enter your system Service Tag in the **Enter your Service Tag** field.
 - b Click **Submit**.
The support page that lists the various support categories is displayed.
- 4 For general support:
 - a Select your product category.
 - b Select your product segment.
 - c Select your product.
The support page that lists the various support categories is displayed.
- 5 For contact details of Dell Global Technical Support:
 - a Click **Global Technical Support**.
 - b The **Contact Technical Support** page is displayed with details to call, chat, or e-mail the Dell Global Technical Support team.

Documentation feedback

You can rate the documentation or write your feedback on any of our Dell documentation pages and click **Send Feedback** to send your feedback.