

Dell EMC DSS 9000 Installation and Service Manual

Regulatory Model: B11S Series
Regulatory Type: B11S001



Notes, cautions and warnings



NOTE: A NOTE indicates important information that helps you make better use of your system.



CAUTION: A CAUTION indicates either potential damage to hardware or loss of data and tells you how to avoid the problem.



WARNING: A WARNING indicates a potential for property damage, personal injury, or death.

Copyright © 2017 Dell Inc. or its subsidiaries. All rights reserved. Dell, EMC, and other trademarks are trademarks of Dell Inc. or its subsidiaries. Other trademarks may be trademarks of their respective owners.

2017 - 10

Rev. A00

Contents

1	Overview	1
	Rack specifications	2
2	Rack accessories overview	4
	Server blanks	4
	Power supply unit (PSU) blanks (optional)	6
	Side panels (optional)	7
	Shipping brackets	7
	PDU brackets	8
	Power bay protectors	8
	Bus bar protectors	9
	Rack blank fillers	9
	IM blank fillers	11
	Locating Service Tag of your system	11
3	Rear cabinet overview	12
	Rear cabinet specifications	14
	Block control distribution boards (BCDB)	15
	Block controller (BC) modules	16
	Fan power distribution boards (FPDB)	17
	Fan modules	18
4	Power bay overview	19
	Power bay specifications	20

Power bay unit	21
Front view	21
Power bay allocation	21
Rear view	22
Power supply unit (PSU)	23
Power bay power module (PBPM)	24
Management controller (MC) module	25
Rear IO module	26
DSS 9000 rack manager module	28
5 Bus bar overview	30
Rack level bus bar	30
Bus bar top	30
Bus bar middle	31
Bus bar bottom	31
Block level bus bar	33
One third-width cross bus bar block	33
Half-width/full-width cross bus bar block	34
Power bay level bus bars	35
Bus bar-PB	36
6 Installing and removing system components	37
Recommended tools	37
Service parts list	37
Servers	39
Removing one third-width server	39
Installing one third-width server	40
Removing half-width server	41
Installing half-width server	42
Removing full-width server	43
Installing full-width server	44
Hard disk drive (HDD) trays	45
Removing HDD tray	45
Installing HDD tray	49

Power supply units (PSU)	52
Removing PSU	52
Installing PSU	52
Fan modules	53
Removing fan module.	53
Installing fan module	55
Fan blocks	56
Removing fan block.	56
Installing fan block	57
Fan power distribution boards (FPDB)	58
Removing FPDB	58
Installing FPDB	59
Block Controller Distribution Board (BCDB)	62
Removing BCDB	62
Installing BCDB	64
Block controllers (BC)	67
Removing BC	67
Installing BC.	67
Management controllers (MC)	69
Removing MC	69
Installing MC	70
Rack manager board (RMB) and infrastructure module (IM)	71
Removing DSS 9000 rack manager module.	71
Installing DSS 9000 rack manager module	72
Removing IM	73
Installing IM.	74
Rear IO modules	74
Removing rear IO module.	74
Installing rear IO module	75
Power interface board (PIB)	76
Removing PIB	76
Installing PIB	79

7	Troubleshooting	85
	Troubleshooting list	85
8	Getting help	87
	Contacting Dell.	87
	Documentation feedback	87

Safety instructions

Read and follow this important safety information. Failure to do so, or use of controls, adjustments, procedures, connections, or signal types other than those specified in your documentation, can result in personal injury or death, and damage to your equipment.

Warnings and cautions

 **WARNING: A WARNING indicates a potential for property damage, personal injury, or death.**

 **CAUTION: A CAUTION indicates a potential for damage to hardware or loss of data if instructions are not followed.**

For additional important regulatory and safety information for the equipment addressed by this document, see the Regulatory Compliance website at dell.com/regulatory_compliance. For more information about your system, see support.dell.com.

General safety

 **WARNING: Observe the following instructions to help prevent potential for property damage, personal injury, or death:**

- The power supplies in your system may produce high voltages and energy hazards. Opening or removing covers that are marked with the triangle symbol with a lightning bolt may expose you to a risk of electric shock. Components inside these compartments should be serviced only by a trained service technician.



- The system may have more than one power supply cable. To reduce the risk of electrical shock, a trained service technician may need to disconnect all power supply cables before servicing the system.
- You may find the following symbols on your rating label on your Dell product:

Input

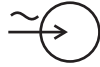

AC Input



DC Input

Output



AC Output



DC Output

- Do not operate your equipment with any cover(s) removed.
- The internal components, including memory modules, can become extremely hot during operation. Allow sufficient time to cool before handling.
- Do not use damaged equipment, including exposed, frayed, or damaged power cords.
- When connecting or disconnecting power to hot-pluggable power supplies:
 - Install the power supply before connecting the power cable to the power supply.
 - Unplug the power cable before removing the power supply.
 - Disconnect all sources of power from the system by unplugging all power cables from the power supplies.
- Do not use the equipment where it can get wet. Protect equipment from liquid intrusion. If your equipment gets wet, disconnect power to the equipment and to any attached devices. If the computer is connected to an electrical outlet, turn off the AC power at the circuit breaker before attempting to remove the power cables from the electrical outlet. Disconnect any attached devices.
- Do not push any objects into the air vents or openings of the equipment. Doing so can cause fire or electric shock.
- To prevent risk of exposure to laser, do not disable or open any Optical Disk Drives (ODD), such as a CD-ROM, CDR/W, DVD drive assembly.



CAUTION: Observe the following instructions to help prevent damage to hardware or loss of data:

- Do not attempt to service the equipment yourself, except as explained in your documentation or in instructions otherwise provided to you by Dell. Always follow installation and service instructions closely.
- If your hardware has a voltage selection switch on the power supply, be sure to set it for the voltage that most closely matches the AC power available at your location.

- Operate the equipment only from the type of external power source indicated on the electrical ratings label.
- To avoid possible damage to the system board, wait 30 seconds after turning off the equipment before removing a component from the system board or disconnecting a peripheral device from the equipment.
- For non-rack-mounted servers, leave 102 mm (4 in) minimum of clearance on all vented sides of the equipment to permit the airflow required for proper ventilation. Restricting airflow can damage the equipment or cause overheating.
- Do not stack equipment or place equipment so close together that it is subject to re-circulated or preheated air, such as next to an appliance or exhaust vent.
- Ensure that nothing rests on your equipment's cables.
- Move equipment with care; ensure that all casters and/or stabilizers are firmly connected to the system. Avoid sudden stops and uneven surfaces.
- Review the weight limits referenced in your equipment documentation before placing a monitor or other device on top of your equipment.
- Use only approved power cable(s) rated for the equipment. The voltage and current rating of the cable should be greater than the ratings marked on the equipment.
- Plug the equipment power cables into properly grounded electrical outlets. Do not use adapter plugs or remove the grounding prong from a cable. If you must use an extension cable, use a 3-wire cable with properly grounded plugs.
- Observe extension cable and power strip ratings. Ensure that the total ampere rating of all equipment plugged into the extension cable or power strip does not exceed 80 percent of the ampere ratings limit for the extension cable or power strip.
- To help protect the equipment from fluctuations in electrical power, use a surge suppressor, line conditioner, or uninterruptible power supply (UPS).



WARNING: Incorrectly installing a battery or using an incompatible battery may increase the risk of fire or explosion. Replace the battery only with the same or equivalent type.

- Do not disassemble, crush, or puncture batteries.
- Do not store or place your battery pack next to or in a heat source such as a fire, heat generating appliance, car or exhaust vent. Heating battery cells to temperatures above 65 °C (149 °F) can cause explosion or fire.
- Do not attempt to open or service batteries. Do not dispose of batteries in a fire or with household waste. For more details, see Battery Disposal instructions.



WARNING: Additional Instructions for Rack-Mounted Systems

 **CAUTION:** If installed in a closed or multi-unit rack assembly, the operating ambient temperature of the rack environment may be greater than room ambient. Therefore, consideration should be given to installing the equipment in an environment compatible with the maximum ambient temperature (T_{ma}) specified by the manufacturer. For more information, see your product documentation.

- Your rack kit has been approved only for the rack cabinet provided. It is your responsibility to ensure that installation of the equipment into any other rack complies with all applicable standards. Dell disclaims all liability and warranties with respect to combinations of equipment with any other rack.
- Before installing your equipment in a rack, install all front and side stabilizers. Failure to install stabilizers can allow the rack to tip over.
- Always load from the bottom up, and load the heaviest items first.
- Do not overload the AC power supply branch circuit that provides power to the rack.
- Do not stand or step on any components in the rack.

 **WARNING:** Slide/rail mounted equipment is not to be used as a shelf or work space

- Before working on the rack, ensure that the stabilizers are secured to the rack, extended to the floor, and that the full weight of the rack rests on the floor. Install front and side stabilizers on a single rack or front stabilizers for joined multiple racks before working on the rack.
- After installing equipment/components in a rack, never pull more than one component out of the rack on its slide assemblies at one time.
- The weight of more than one extended component could cause the rack to tip over and may result in serious injury.



Do not add weight to slide or rail-mounted equipment.



The GS Mark indicates the product was tested and complies with the minimum requirements of the German Product Safety Act (a.k.a. ProdSG).

The following statement applies only to rack-installed products that are GS-Marked: This equipment is not intended for use at workplaces with visual display units, in accordance with §2 of the German ordinance for workplaces with visual display units.

 **WARNING:** For equipment using **-(48–60) V DC power supplies, a qualified electrician must perform all connections to DC power and to safety grounds. Do not attempt connecting to DC power or installing grounds yourself. All electrical wiring must comply with applicable local or national codes and practices.**

Instructions for qualified electricians only:

Systems using –(48–60) V DC Power Supplies are intended for restricted access locations in accordance with Articles 110-5, 110-6, 110-11, 110-14, and 110-17 of the National Electrical Code, American National Standards Institute (ANSI)/National Fire Protection Association (NFPA) 70.

Before connecting safety ground or power cables, ensure that the power is removed from the DC circuit. To ensure that the power is off, locate the circuit breaker on the DC source circuit (usually at the power distribution of the battery distribution fuse bay). Switch the circuit breaker to the off position and, if available, install an approved safety locking device on the circuit breaker or switch.

While grounding techniques may vary, a positive connection to a safety (earth) ground is a requirement. When installing the unit, the ground connection must always be made first and disconnected last to prevent a hazard.

Never defeat the ground conductor or operate the equipment in the absence of a suitably installed ground conductor. Contact the appropriate electrical inspection authority or an electrician if you are uncertain that suitable grounding is available.

Overview

The DSS 9000 rack enclosure is designed to hold and protect server, network, and data storage equipment.

 **NOTE:** The product at time of delivery may differ from the following illustrations.

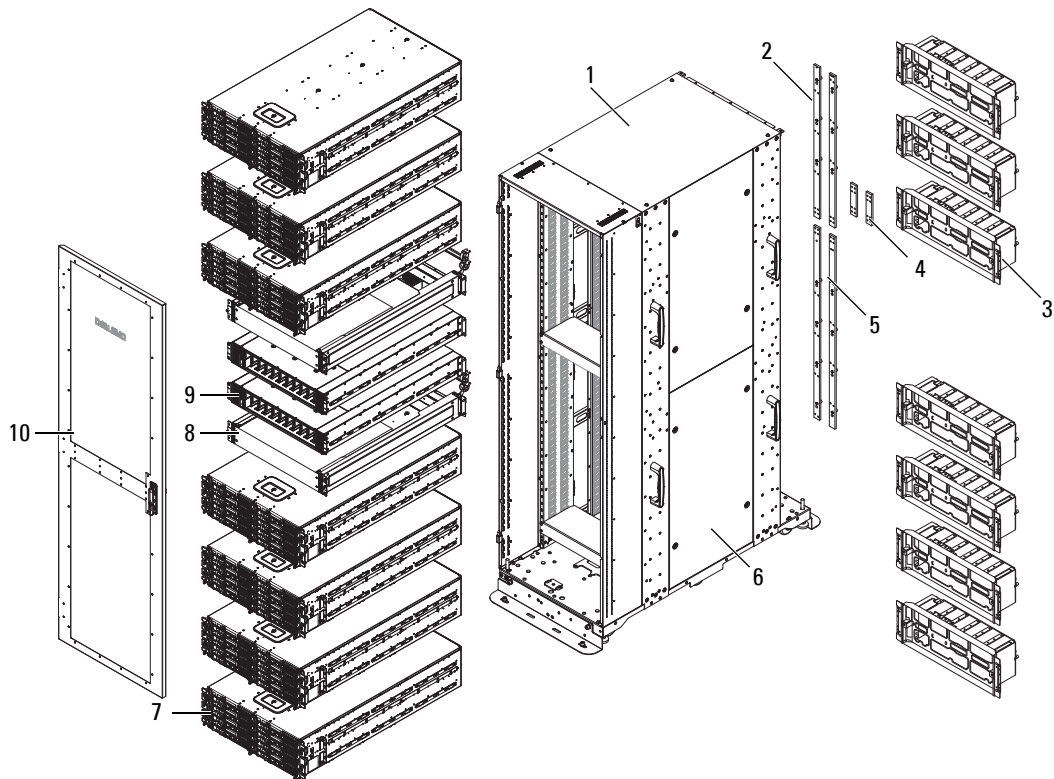

Figure 1. DSS 9000 system

Table 1. DSS 9000 features

No.	Feature	Description
1	Bare rack	Rack mounting enclosure for DSS 9000 system equipment.
2	Bus bar top	Bar strip located on top of the rack conducts electricity. Based on rack layout, two different types of top bus bars can be assembled. For more information about bus bars, see Bus bar top.
3	Rear cabinet	The rear cabinet houses twelve system fans, one block controller distribution board (BCDB), one block controller (BC), one fan cage, one fan power distribution board (FPDB), and one rear cabinet base.
4	Bus bar middle	Bridge bus bar located between top and bottom bus bars. For more information about bus bars, see Bus bar middle.
5	Bus bar bottom	Bar strip located on bottom of the rack conducts electricity. For more information about bus bars, see Bus bar bottom.
6	Side panel (optional)	Rack cabinet filler panel (optional).
7	Block chassis	Three types of block chassis (one third-width, half-width, and full-width).
8	OpenIT bay	Two switch devices are available to provide networking for the entire system.
9	Power Bay	Located on the front side of rack, provides allocated space for power supply units (PSUs).
10	Front door (optional)	Reversible front door can be configured to open from left or right, with lock.

Rack specifications

Table 2. Rack specifications

Item	Description
Height	Available rack options: <ul style="list-style-type: none"> • 29U: 1,466.4 mm (57.73 inch) • 42U: 1,970.4 mm (77.57 inch) • 44U: 2,071.2 mm (81.54 inch) • 48U: 2,272.8 mm (89.48 inch) • 50U: 2,373.6 mm (93.45 inch)
Width	600 mm (23.62 inch)
Depth	1,200 mm (47.24 inch)

Table 2. Rack specifications (continued)

Item	Description
Net weight	<ul style="list-style-type: none">• 29U: 162.4 kg (358 lb)• 42U: 201.4 kg (444 lb)• 44U: 207.3 kg (457 lb)• 48U: 219.1 kg (483 lb)• 50U: 225.0 kg (496 lb)

Rack accessories overview

The DSS 9000 rack enclosure offers server and power supply blanks as well as shipping brackets, bus bar protectors and optional side panel accessories.

Server blanks

The following lists the available server blanks for the DSS 9000: full width, half width, and one third width blank chassis.

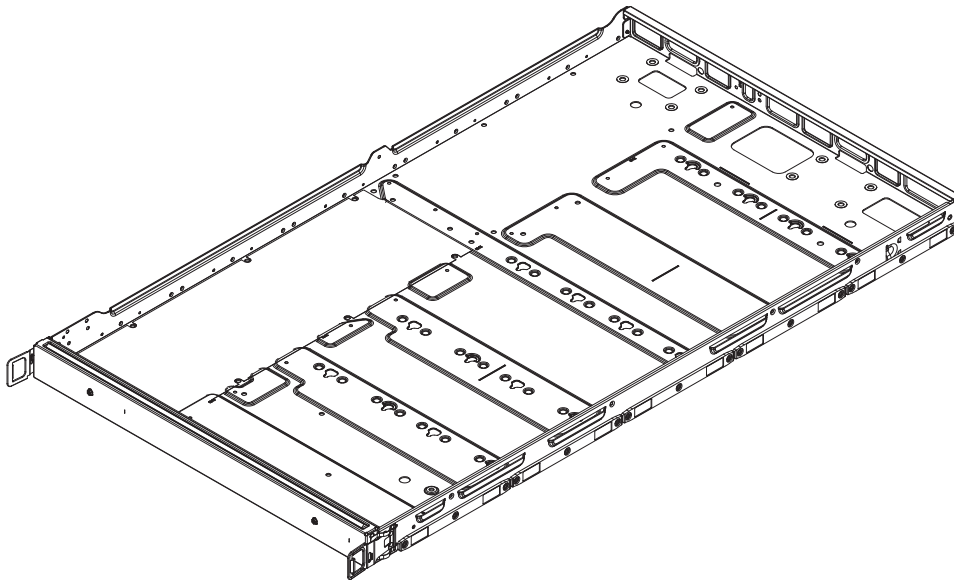

Figure 2. Full-width server blank

Table 3. Full-width server blank features

Item	Description
Dimensions (W x L x H)	527 mm x 930 mm x 47 mm (20.75 inch x 36.61 inch x 1.85 inch)

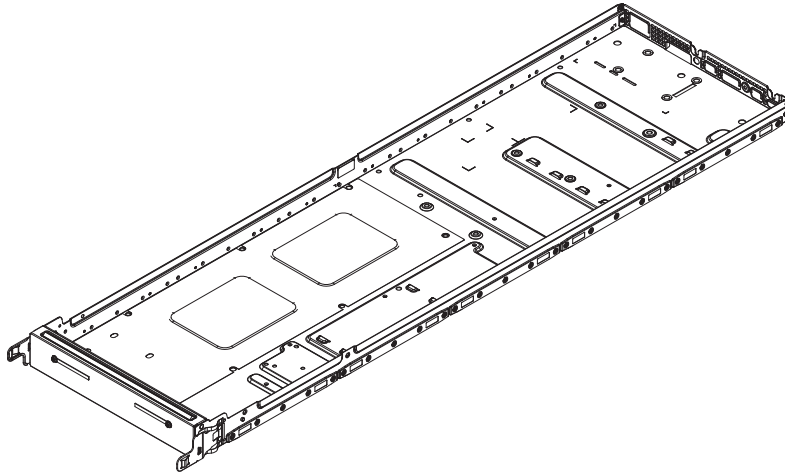

Figure 3. Half-width server blank

Table 4. Half-width server blank features

Item	Description
Dimensions (W x L x H)	262.2 mm x 930 mm x 47 mm (10.32 inch x 36.61 inch x 1.85 inch)

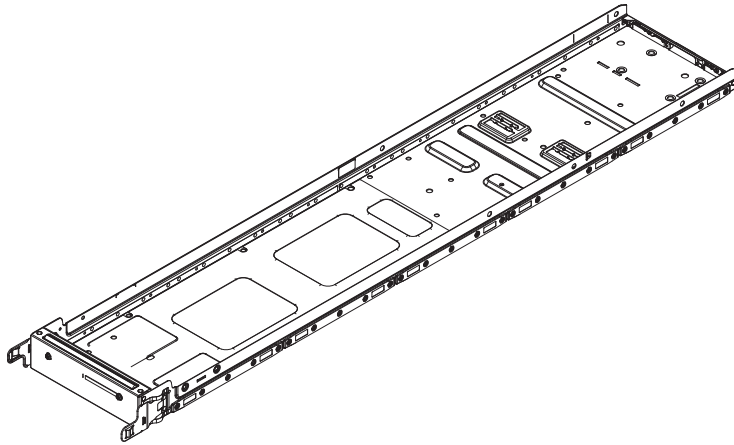

Figure 4. One third-width server blank

Table 5. One third-width server blank features

Item	Description
Dimensions (W x L x H)	174.3 mm x 930 mm x 47 mm (6.86 inch x 36.61 inch x 1.85 inch)

Power supply unit (PSU) blanks (optional)

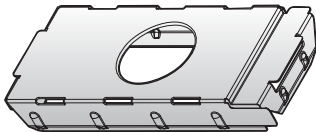

Figure 5. PSU blank

Side panels (optional)



Figure 6. Filler panel

Shipping brackets

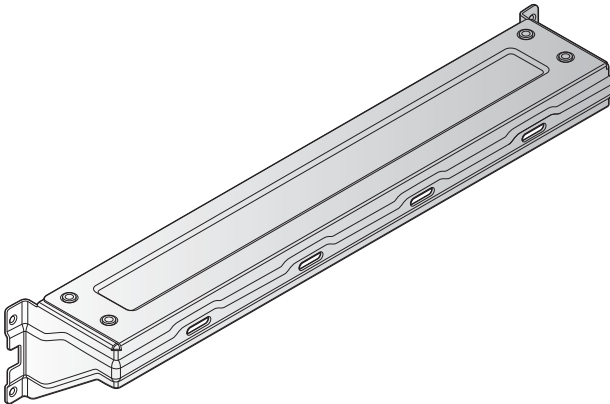

Figure 7. Shipping bracket

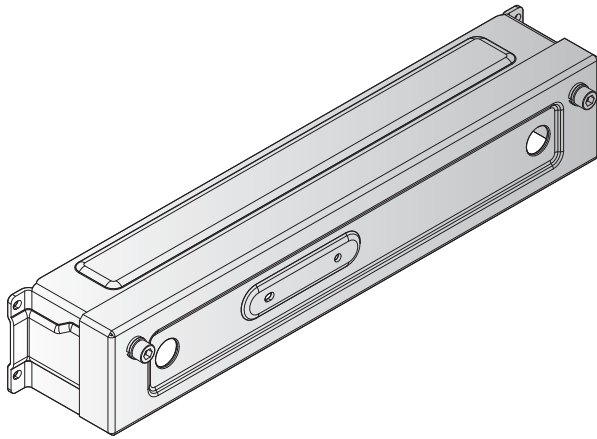

Figure 8. Shipping bracket

PDU brackets

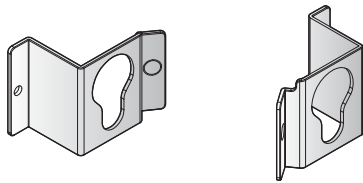

Figure 9. PDU bracket

Power bay protectors

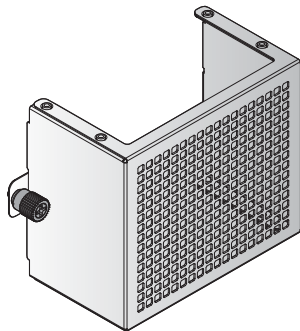

Figure 10. Power bay protector

Bus bar protectors

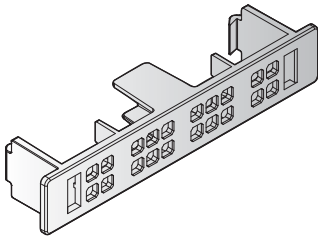

Figure 11. 0.5GU bus bar protector

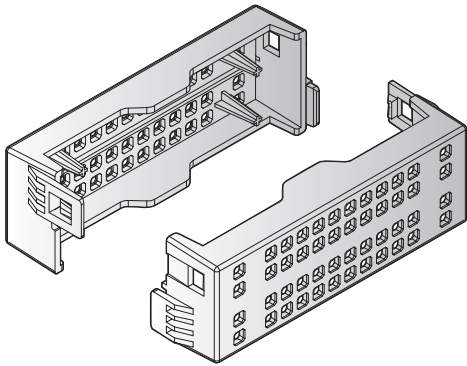

Figure 12. 1GU bus bar protector

Rack blank fillers



Figure 13. 1GU rack blank fillers

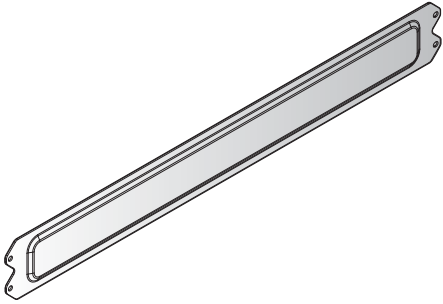

Figure 14. 2GU rack blank fillers

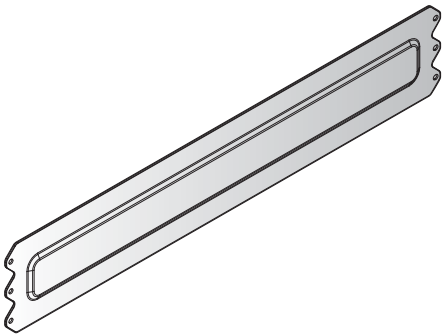

Figure 15. 3GU rack blank fillers

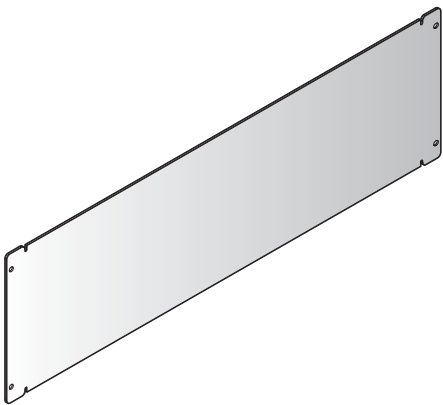

Figure 16. 5GU rack blank fillers

IM blank fillers

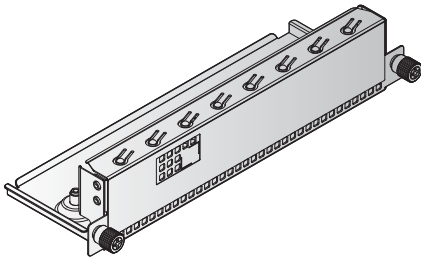

Figure 17. IM blank fillers

Locating Service Tag of your system

Your system is identified by a unique Express Service Code and Service Tag number. The information is on a sticker on the right-front of the system. This information is used by Dell to route support calls to the appropriate personnel.

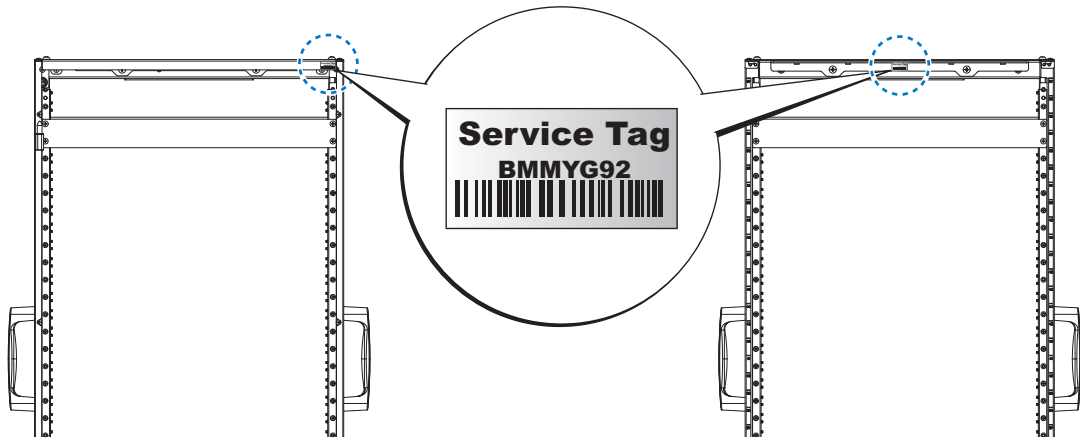

Figure 18. Service Tag location

Rear cabinet overview

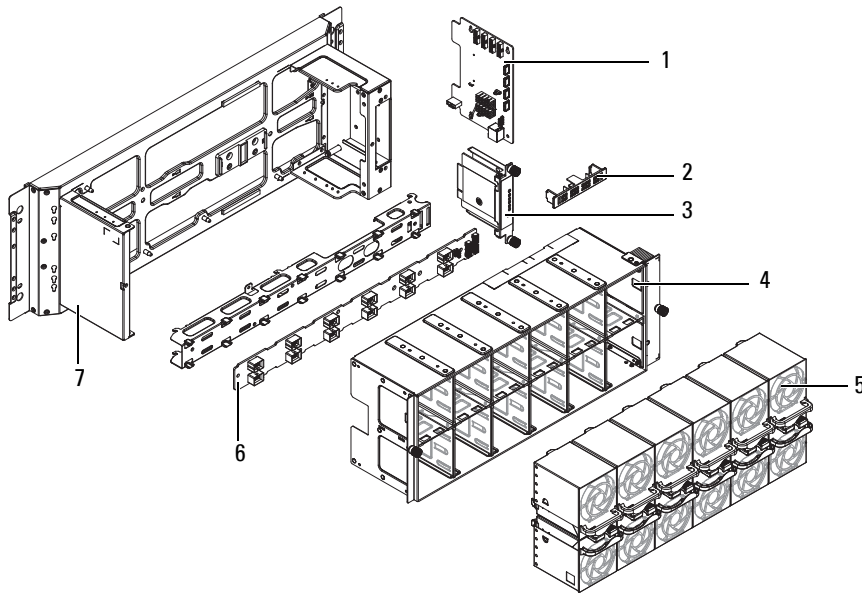

Figure 19. Rear cabinet exploded view

Table 6. Rear cabinet features

No.	Item	Description
1	BCDB (Block Controller Distribution Board)	<ul style="list-style-type: none"> • 1 x PCIe x8 connector • 4 x Fan zone connector • 4 x PIB connector • 1 x RJ45 • 1 x Temperature sensor connector
2	0.5U bus bar protector	Cover to prevent contact with the bus bar.

Table 6. Rear cabinet features (continued)

No.	Item	Description
3	BC (Block Controller)	Connectors <ul style="list-style-type: none">• 1 x PCIe x8 golden finger• 1 x RS232• 1 x JTAG LED <ul style="list-style-type: none">• 1 x power / status• 1 x ID• 4 x fan fail Switch <ul style="list-style-type: none">• Reset switch (local)
4	Fan cage	Supports up to twelve fan modules Width: 480 mm (18.89 inch) Length: 114.5 mm (4.50 inch) Height: 116.0 mm (4.56 inch)
5	Fan modules	Fan module includes twelve fans.
6	FPDB (Fan Power Distribution Board)	<ul style="list-style-type: none">• 1 x 2x13 connector• 1 x 2x10 connector• 12 x 2x4 connectors
7	Rear cabinet base	Supports up to twelve fan modules

Rear cabinet specifications

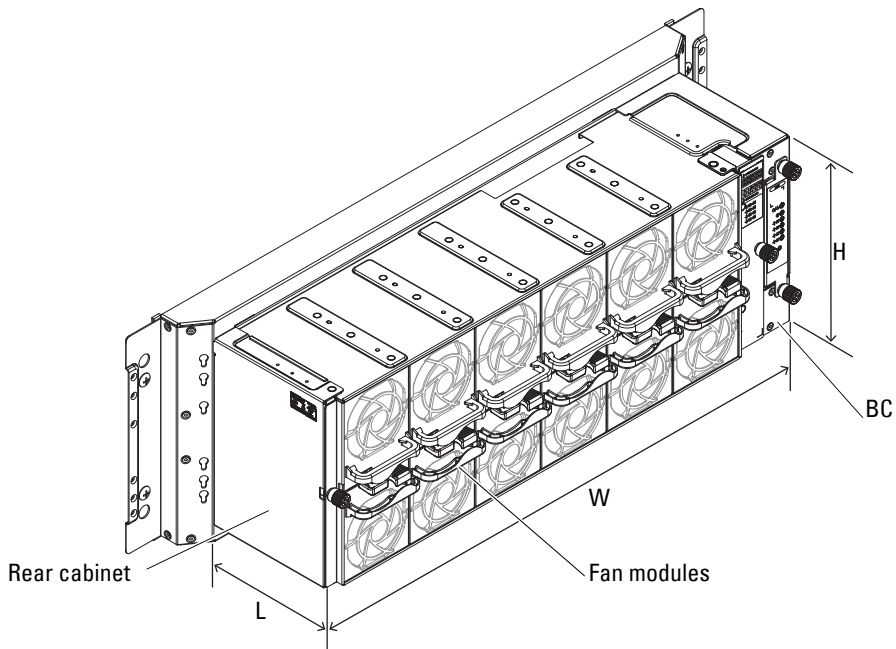

Figure 20. Rear cabinet

Table 7. Rear cabinet features

Item	Description
Rear cabinet	Includes fan modules, fan cage, FPDB, BC, BCDB, and power strip brackets.
Dimensions (W x L x H)	480 mm x 114.5 mm x 167 mm (18.9 inch x 4.51 inch x 6.57 inch)

Block control distribution boards (BCDB)

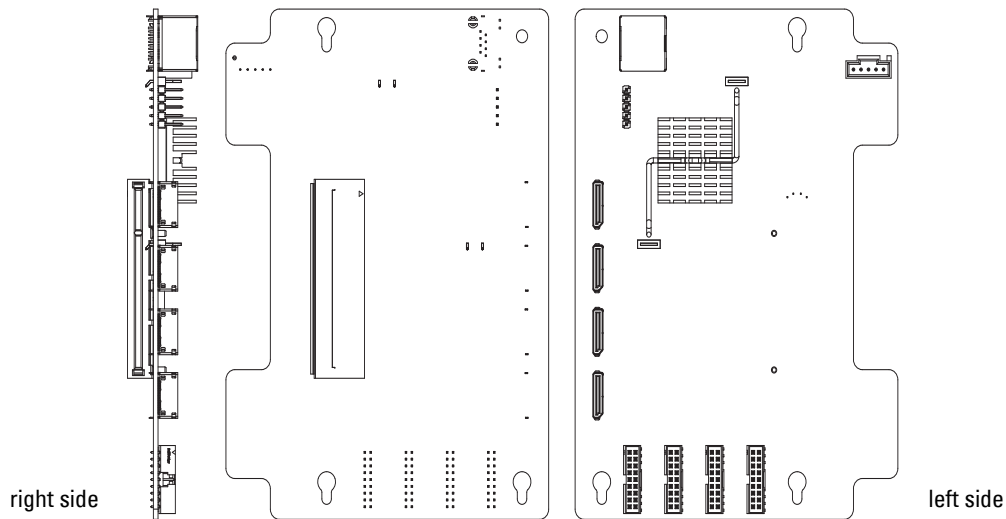

Figure 21. Block control distribution board

Table 8. Block control distribution board features

Item	Description
Dimension (W x L x H)	150 mm x 109 mm x 1.5 mm (5.90 inch x 4.29 inch x 0.06 inch), 8 layers
Connector	<ul style="list-style-type: none"> • 4 x FAN Zone connector • 1 x RJ45 • 4 x NPIO connector • 1 x HTPB connector • 1 x BC connector • 1 x BCM UART connector
Net weight	78.6 g (2.77 ounce)
Operating voltage/current	12 V, current 0.2 A

LED definition

Table 9. LED

LED	Color	Status	Description
LED (Left)	Amber	Solid	Link speed: 100Mb
		Off	Disconnected
LED (Right)	Green	Blinking	LAN access

Block controller (BC) modules

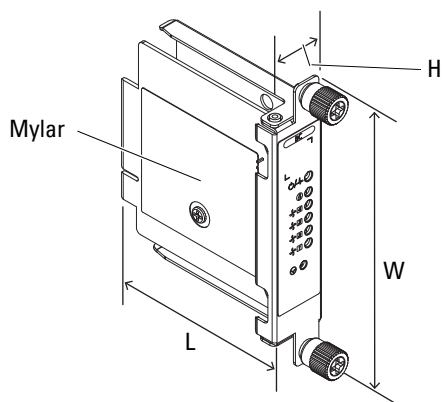

Figure 22. BC module

Table 10. BC module features

Item	Description
Dimension (W x H x L)	120 mm x 24 mm x 88 mm (4.72 inch x 0.94 inch x 3.46 inch)
Connector	<ul style="list-style-type: none">• 1 x PCIe x8 golden finger• 1 x RS232• 1 x JTAG
Switch	1 x Reset SW (Local)
Net weight	127.2 g (4.49 ounce)
Operating voltage/current	3.3 V, current 1 A

LED definition

Table 11. LED

LED	Color	Status	Description
Power/Status	Green	On	If there is no error
	Amber	On	If there is an error from anyone of these: (Mac address, Fan image, FPGA image, Mosfet, Ethernet link, I ² C, FPGA configuration).
		Blinking	Infrastructure mismatch
UID	Blue	On/Off/Blinking	Identify BC board location
Fan zone 1~2	Amber	On	Fan fail
		Off	Normal work

Fan power distribution boards (FPDB)

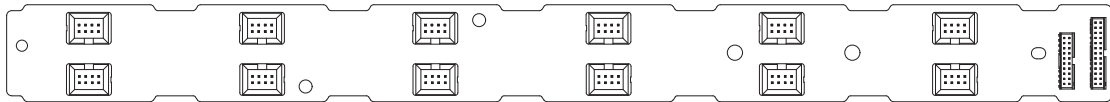

Figure 23. Fan power distribution board

Table 12. Fan power distribution board features

Item	Description
Board length	433 mm (17.05 inch)
Board width	38 mm (1.5 inch)
Connector	<ul style="list-style-type: none">• 1x (2x10) connector• 1x (2x13) connector• 12 x (2x4) connector
Net weight	129.2 g (4.56 ounce)
Operating voltage/current	12 V, current 32 A

Fan modules

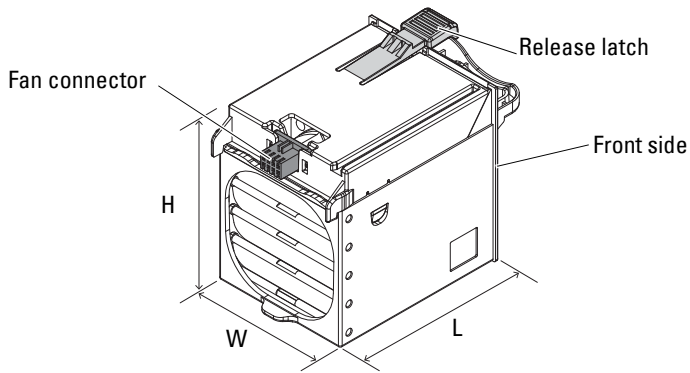

Figure 24. Fan module

Table 13. Fan module features

Item	Description
Dimensions (W x L x H)	64.6 mm x 106.2 mm x 78.4 mm (2.54 inch x 4.18 inch x 3.08 inch)

Power bay overview

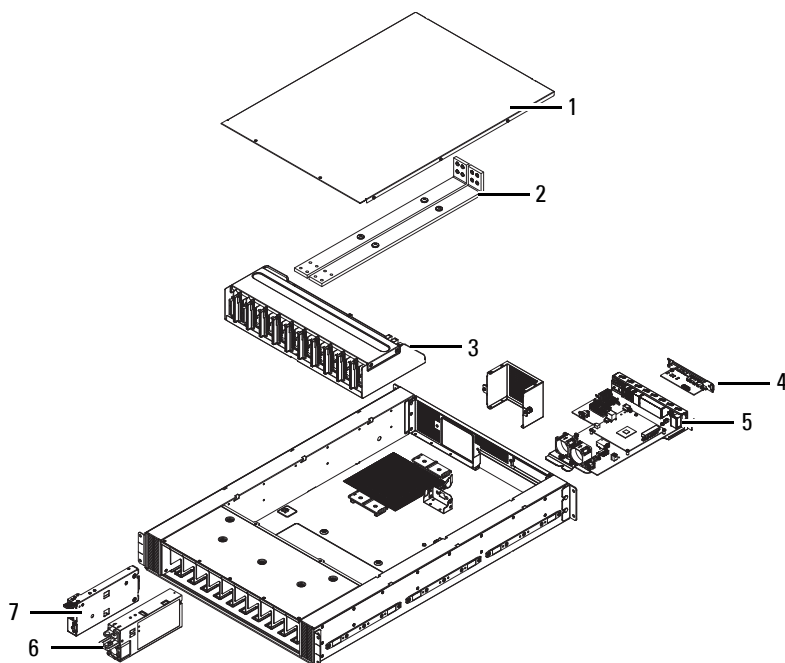

Figure 25. Power bay exploded view

Table 14. Power bay features

No.	Item	Description
1	Top cover	Top cover for the power bay chassis.
2	Bus Bar PB	Bar strip to conduct electricity within the power bay.
3	PBPM	Power bay power module regulates power control for the PSU.
4	Rear IO module	Four RJ45 connectors, one 1x5 connector, one 1x6 connector and one 2x8 connector.
5	DSS 9000 rack manager module	Includes rack manager board (RMB) and infrastructure module (IM). MC and blocks of the IM are networked through a LAN.

Table 14. Power bay features (continued)

No.	Item	Description
6	Power supply unit (PSU)	Ten hot-swappable power supply units.
7	Management controller module	Monitoring through the on-board GbE to provide real-time two-way fan speed and power status and operational event information.

Power bay specifications

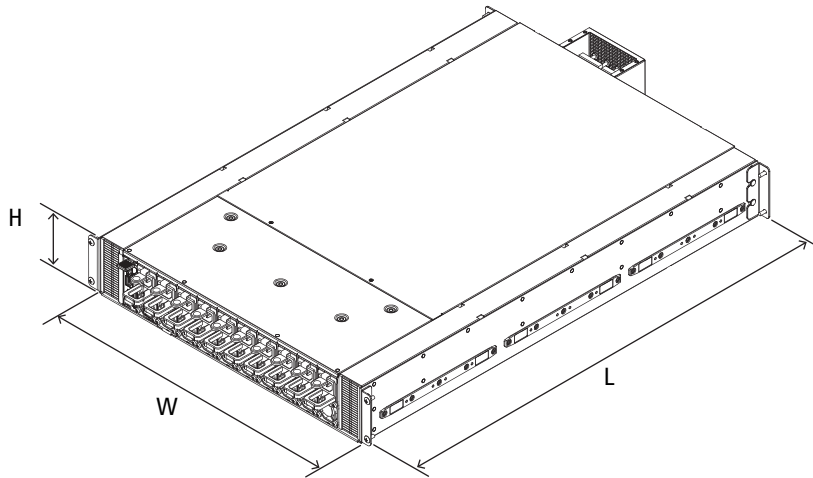

Figure 26. Power bay

Table 15. Power bay features

Item	Description
Dimensions (W x L x H)	537 mm x 800 mm x 98.6 mm (21.14 inch x 31.50 inch x 3.88 inch)
Output	<ul style="list-style-type: none"> • Ripple/CS accuracy same as specified in PSU specifications • Static regulation/dynamic regulation at bus bar as definition location in PBPM specifications. • On/Off capacity through PMBus control • Up to 10 kW (single PB with 5+5) • Up to 18 kW (single PB with 9+1)

Power bay unit

The DSS 9000 leverages a power bay which houses up to ten AC power supply units (PSUs) to fully support the operational requirements of the rack enclosure.

Front view

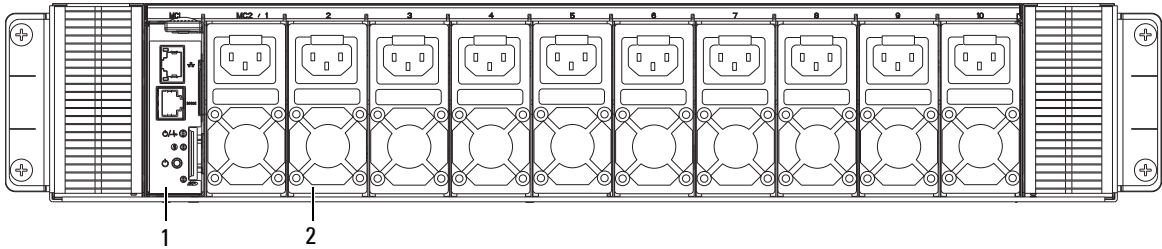

Figure 27. Power bay 1 MC + 10 PSU model (front view)

Table 16. Power bay 1 MC + 10 PSU model (front view)

No.	Item	Description
1	MC	One management controller module
2	Power supply unit	Ten hot-swappable power supply unit bays

Power bay allocation

When populating the PSU bays make sure to first populate bays 1 to 6 then 7 to 10 as required. A minimum of six power supply units are required to effectively sustain operations.

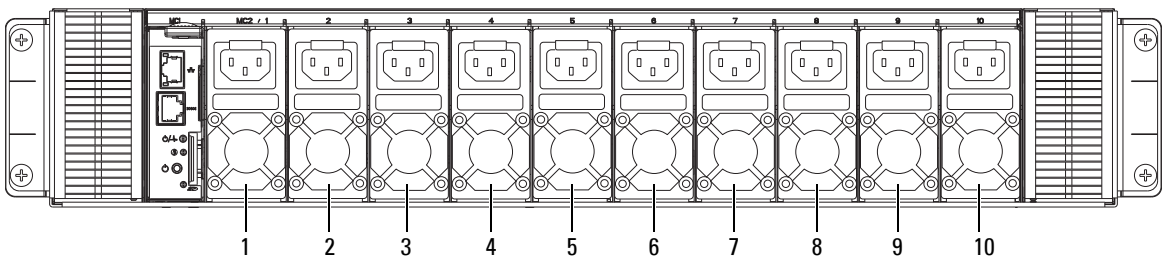

Figure 28. Power bay allocation

NOTE: To meet power requirements a minimum of six power supply units must be installed. Make sure to first populate power bays 1 to 6.

Rear view

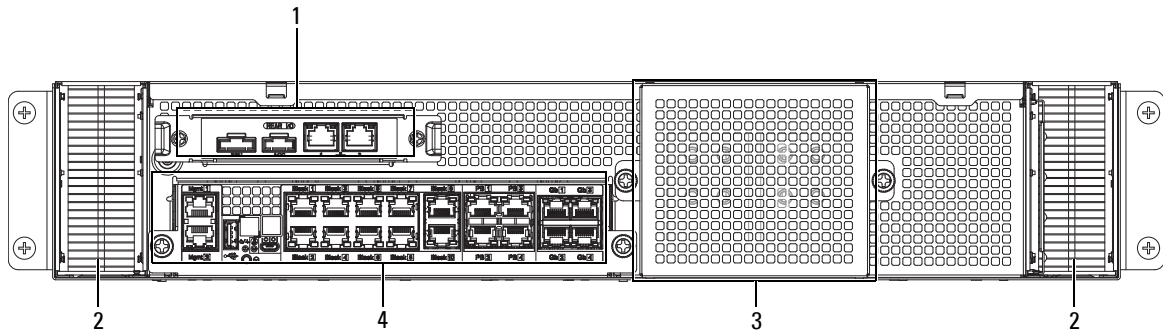

Figure 29. Power bay overview (rear view)

Table 17. Power bay overview (rear view)

No.	Item	Description
1	Rear IO	<ul style="list-style-type: none"> • RJ45 connectors (x 4) • 1x5 connector (x 1) • 1x6 connector (x 1) • 2x8 connector (x 1)
2	Brush panel	Allows cabling to be fed to or from the rear of the cabinet and prevents dust ingress.
3	1U bus bar protector	Cover to prevent contact with the bus bar and an electrical short circuit.
4	Infrastructure module	<ul style="list-style-type: none"> • Includes RJ45 ports • UID, power/status LEDs • Reset button • ICs: MCU, Ethernet switch, SPI ROM, EEPROM, TMP sensor, and RS232 driver/receiver

Power supply unit (PSU)

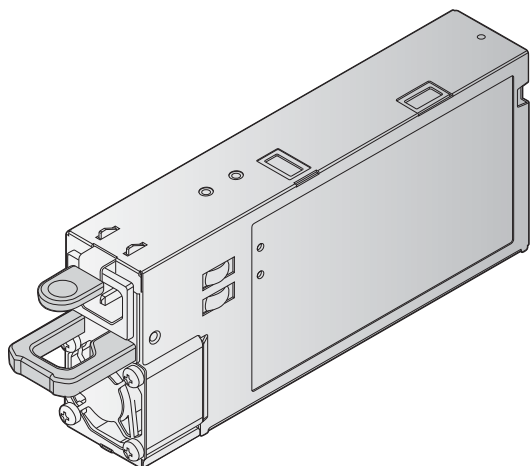

Figure 30. Power supply unit (PSU)

Table 18. Power supply unit (PSU)

Item	Description
Operating Temperature	10°C to 50°C (50°F to 122°F)

LED definition

Table 19. LED

LED	Color	Status	Description
PSU LED	Green	Solid	OK
	Amber	Blinking	Fault
		Off	Off

PSU specifications

Table 20. PSU specifications

PSU wattage	Class	Heat dissipation (maximum)	Frequency	Voltage	Maximum input current
2000 W AC	Platinum	675.37 BTU/hr	50/60 Hz	100–240 V AC, autoranging	11.5 A

 **NOTE:** Heat dissipation is calculated using the PSU wattage rating.

NOTE: This system is also designed to connect to the IT power systems with a phase to phase voltage not exceeding 230 V.

Power bay power module (PBPM)

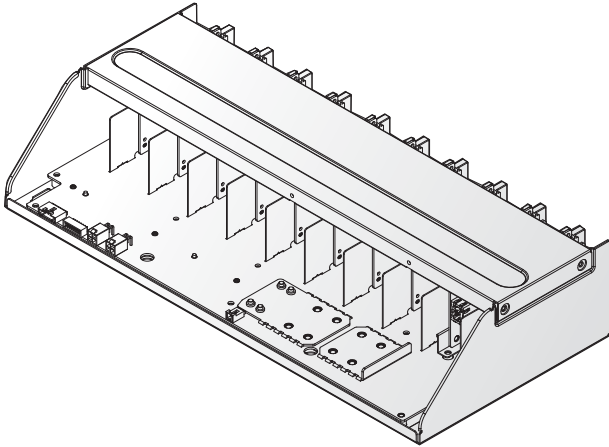

Figure 31. Power bay power module (PBPM)

Table 21. Power bay power module (PBPM)

Item	Description
Power bay	<ul style="list-style-type: none">• Supports multiple (max. 10) PSUs, each up to 2000 W PSU• Supports up to two management controller cartridges

Management controller (MC) module

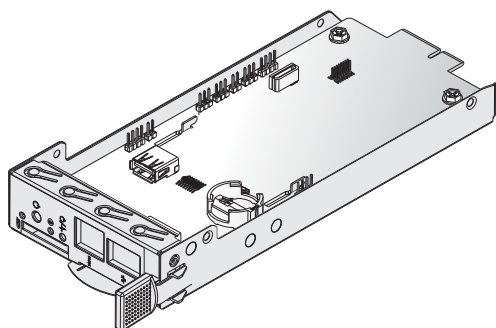

Figure 32. Management controller

Table 22. Management controller

Item	Description
Board length	204.1 mm (8.03 inch)
Board width	82 mm (3.22 inch)
Net Weight	79 g (2.78 ounce.)
Connector	<ul style="list-style-type: none">• 1 x PCIe x4 Gold-finger• 1 x RJ45• 1 x Serial RJ45• 1 x SD socket• 1 x USB• 1 x JTAG• 1 x Battery holder
Switch	1 x Power Button
Operating voltage/current	12 V, current 1.3 A

LED definition

Table 23. LED

LED	Color	Status	Description	
LAN port	Status	Green	On	1G LAN speed
		Amber	On	10M/100M LAN speed
Activity	Green	Blinking	Traffic access	

Table 23. LED (continued)

LED	Color	Status	Description
Power/Status	Green	On	Power on
	Amber	On	Power on fail
UID	Blue	On/Off/Blinking	Identify MC board location
Error	Green	On	If there is no error
	Amber	Blinking	Infrastructure mismatch
		On	Link between MC and IM is Absent

Rear IO module

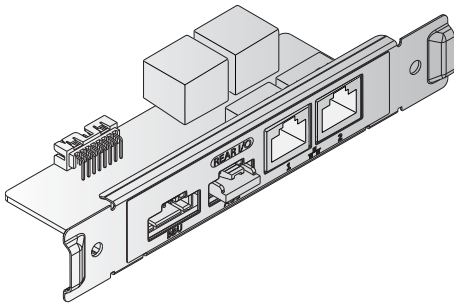

Figure 33. Rear IO module

Table 24. Rear IO module

Item	Description
Board length	105 mm (4.13 inch)
Board width	40 mm (1.57 inch)
Net weight	62.2 g (2.19 ounce)
Connector	<ul style="list-style-type: none">• 4 x RJ45 connector• 1 x (1x5) connector• 1 x (1x6) connector• 1 x (2x8) connector

LED definition

Table 25. LED

LED	Color	Status	Description
LAN1 port			
Status	Green	On	1G LAN speed
	Amber	On	10M/100M LAN speed
Activity	Green	Blinking	Traffic access
LAN2 port			
Status	Green	On	10M/100M LAN speed
	Amber	On	1G LAN speed
Activity	Green	Blinking	Traffic access

DSS 9000 rack manager module

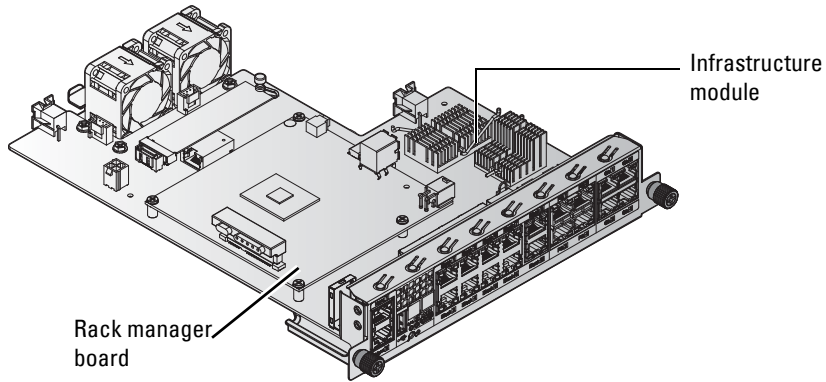

Figure 34. DSS 9000 rack manager module

Table 26. DSS 9000 rack manager module features

Item	Description
Board length	323.25 mm (12.73 inch)
Board width	242.3 mm (9.54 inch)
Net weight	1,050 g (37.03 ounce)
Connector	<ul style="list-style-type: none">• 2 x 8-port RJ45• 1 x 2-port RJ45• 1 x (2x2) Power connector• 1 x USB• 1 x (1x5) connector• 1 x Micro USB
Switch	1 x Reset Button
Operating voltage/current	12 V, current 2 A

Infrastructure module LED definition

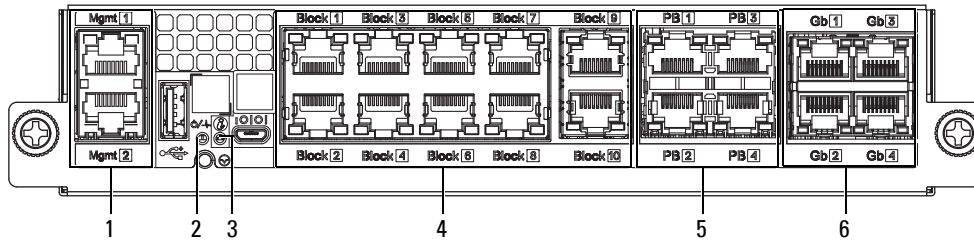

Figure 35. LED definition

Table 27. LED definition

Item	Port	LED	Color	Status	Description
1	Mgmt	Right LED	Green	Blinking	Active
		Left LED	Green	On	Link speed: 1Gb
			Yellow	On	Link speed: Others
			Off	No link	
2	Power/Status		Green	On	Fault not detected
			Amber	On	Fault detected: Mac address, I ² C.
			Blinking	Infrastructure mismatch or fan fault	
3	UID		Blue	On/Off/Blinking	Identify IM board location
4	Block (1-10)	Right LED	Green	Blinking	Active
		Left LED	Green	On	Link speed: 1Gb
			Off	No link	
5	PB (1-4)	Right LED	Green	Blinking	Active
		Left LED	Yellow	On	Link speed: 100Mb
			Off	Link speed: 10Mb or no link	
6	Gb (1-4)	Right LED	Green	Blinking	Active
		Left LED	Green	On	Link speed: 1Gb
			Yellow	On	Link speed: Other
			Off	No link	

Bus bar overview

The DSS 9000 rack enclosure includes bus bar to the following areas:

- Rack level
- Block level
- Power bay level

Rack level bus bar

Bus bar top

The top of the rack includes two bus bars, positive and negative. The bus bars are coupled to the middle bus bars for upward distribution of the system's power.

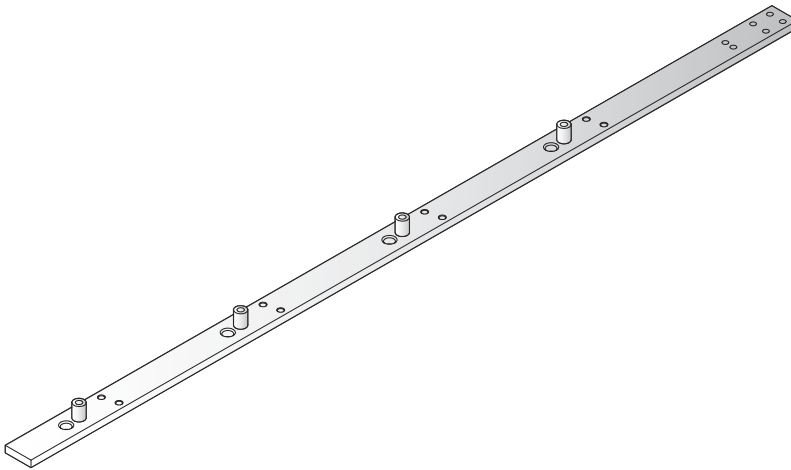

Figure 36. Bus bar top-P (positive, red)

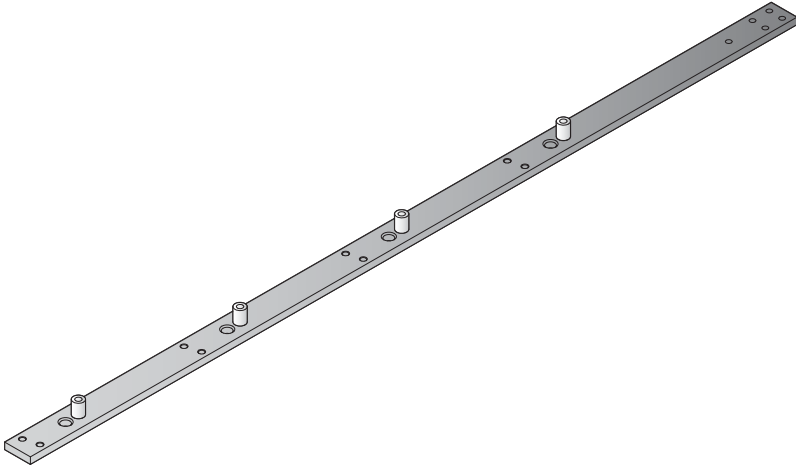

Figure 37. Bus bar top-N (negative, black)

Bus bar middle

The middle of the rack includes two bus bars, positive and negative. The bus bars couple the power block and the top bus bars for upward distribution of the system's power.

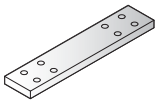

Figure 38. Bus bar middle-P (positive, red)

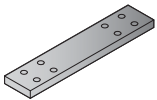

Figure 39. Bus bar middle-N (negative, black)

Bus bar bottom

The bottom of the rack includes two bus bars, positive and negative. The bus bars are coupled to the middle bus bars for downward distribution of the system's power.

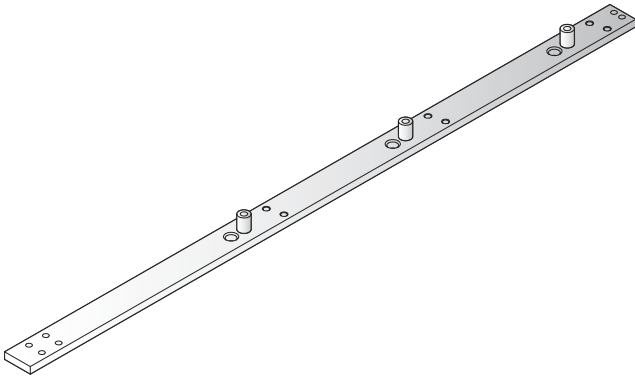

Figure 40. Bus bar bottom-P (positive, red)

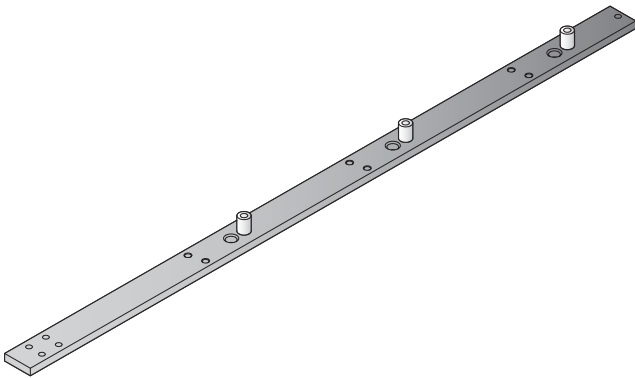

Figure 41. Bus bar bottom-N (negative, black)

Block level bus bar

The following cross bus bar types are specific for the 6GU block.

One third-width cross bus bar block

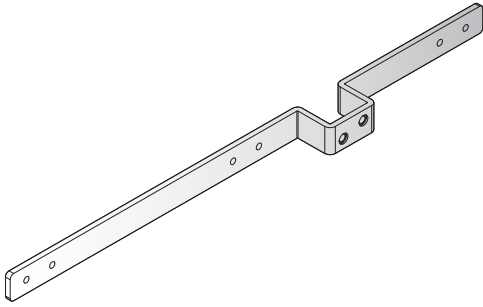

Figure 42. One third-width cross bus bar block-P (positive, red)

Table 28. Third width cross bus bar block-P (positive, red)

Item	Description
Length	334.4 mm (13.17 inch)
Width	20 mm (0.79 inch)
Height	34 mm (1.34 inch)
Thickness	4 mm (0.16 inch)

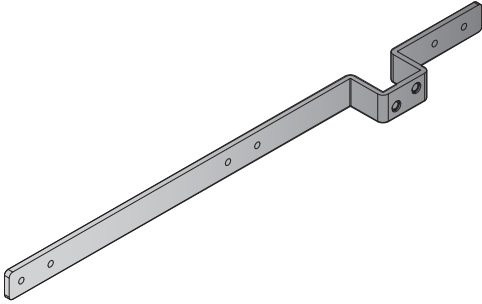

Figure 43. One third-width cross bus bar block-N (negative, black)

Table 29. One third-width cross bus bar block-N (negative, black)

Item	Description
Length	334.4 mm (13.17 inch)
Width	20 mm (0.79 inch)
Height	34 mm (1.34 inch)
Thickness	4 mm (0.16 inch)

Half-width/full-width cross bus bar block

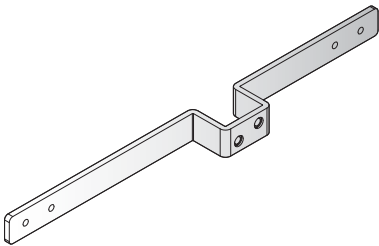

Figure 44. Half-width/full-width cross bus bar block-P (positive, red)

Table 30. Half-width/full-width cross bus bar block-P (positive, red)

Item	Description
Length	334.4 mm (13.17 inch)
Width	20 mm (0.79 inch)
Height	34 mm (1.34 inch)
Thickness	4 mm (0.16 inch)

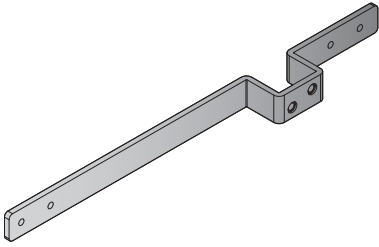

Figure 45. Half-width/full-width cross bus bar block-N (negative, black)

Table 31. Half-width/full-width cross bus bar block-N (negative, black)

Item	Description
Length	334.4 mm (13.17 inch)
Width	20 mm (0.79 inch)
Height	34 mm (1.34 inch)
Thickness	4 mm (0.16 inch)

Power bay level bus bars

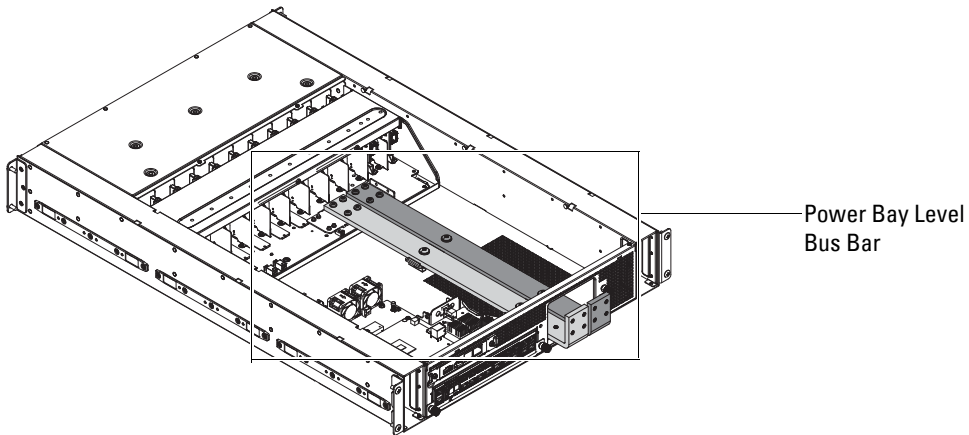

Figure 46. Power bay level bus bar

Bus bar-PB

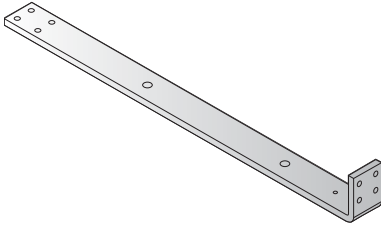

Figure 47. Bus bar-PB-P (positive, red)

Table 32. Bus bar-PB-P (positive, red)

Item	Description
Length	507.7 mm (19.99 inch)
Width	40 mm (1.57 inch)
Height	58.8 mm (2.31 inch)
Thickness	8 mm (0.31 inch)

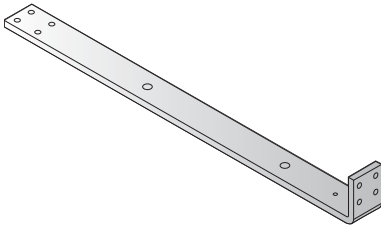

Figure 48. Bus bar-PB-N (negative, black)

Table 33. Bus bar-PB-N (negative, black)

Item	Description
Length	507.7 mm (19.99 inch)
Width	40 mm (1.57 inch)
Height	58.8 mm (2.31 inch)
Thickness	8 mm (0.31 inch)

Installing and removing system components

Safety instructions

⚠ CAUTION: Many repairs may only be done by a certified service technician. You should only perform troubleshooting and simple repairs as authorized in your product documentation, or as directed by the online or telephone service and support team. Damage due to servicing that is not authorized is not covered by warranty. Read and follow the safety instructions that are shipped with your product.

System components and electronic circuit boards can be damaged by discharges of static electricity. Working on systems that are still connected to a power supply can be extremely dangerous. To avoid injury to yourself or damage to system, follow these guidelines:

- Wear a grounded wrist strap when working inside the system chassis.
- Handle electronic circuit boards only by the edges, ensuring not to touch the components on the board. Do not flex or stress the circuit board.
- Store all components inside a static-proof packaging until you are ready to use the components for installation.

Recommended tools

- Phillips screwdriver #2

Service parts list

Table 34. Service parts list

Item
DSS 9000 System
Fan module
Power
• PSU
• PBPM

Table 34. Service parts list (continued)

Item
Mechanical
• PSU blank
• Third width server blank
• Half width server blank
• Full width server blank
PCBA module
• MC
• MC cover
• DSS 9000 rack manager module
• Infrastructure module
• Rear I/O
• BC

Servers

Removing one third-width server

Prerequisites

- 1 Ensure that you read the Safety instructions.

Steps

- 1 Press the release latches on the side of the server.
- 2 Slide the server out of the block.

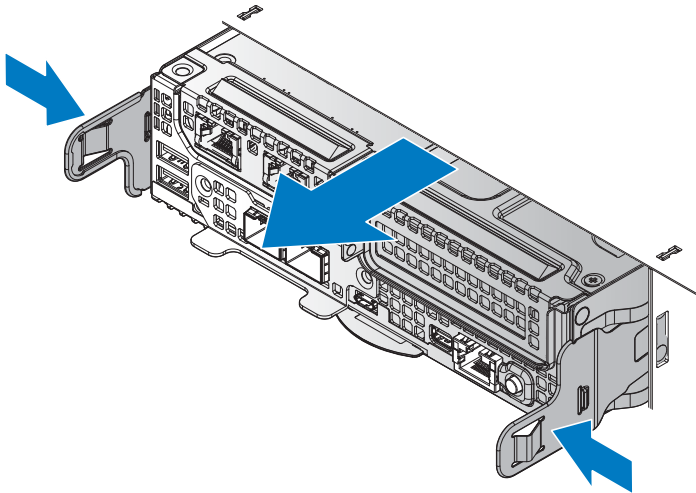

Figure 49. Removing the one third-width server

Installing one third-width server

- 1 Align the server with the bay, and insert the server into the block.
- 2 Slide the server in until it is fully seated in the block.
The server locks in place after it is properly seated.

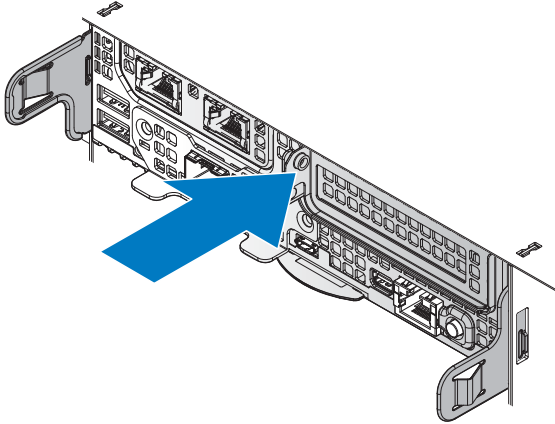

Figure 50. Installing the one third-width server

Removing half-width server

Prerequisites

- 1 Ensure that you read the Safety instructions.

Steps

- 1 Press the release latches on the side of the server.
- 2 Slide the server out of the block.

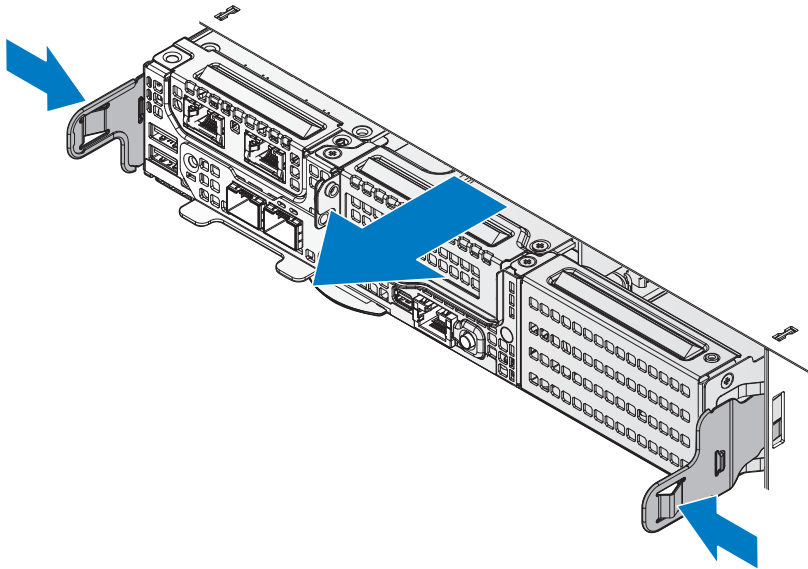

Figure 51. Removing the half-width server

Installing half-width server

- 1 Align the server with the bay, and insert the server into the block.
- 2 Slide the server in until it is fully seated in the block.
The server locks in place after it is properly seated.

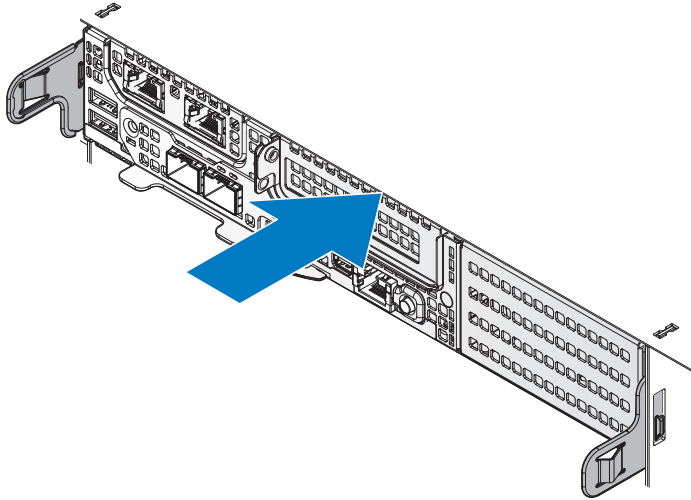

Figure 52. Installing the half-width server

Removing full-width server

Prerequisites

- 1 Ensure that you read the Safety instructions.

Steps

- 1 Press the release latches on the side of the server.
- 2 Slide the server out of the block.

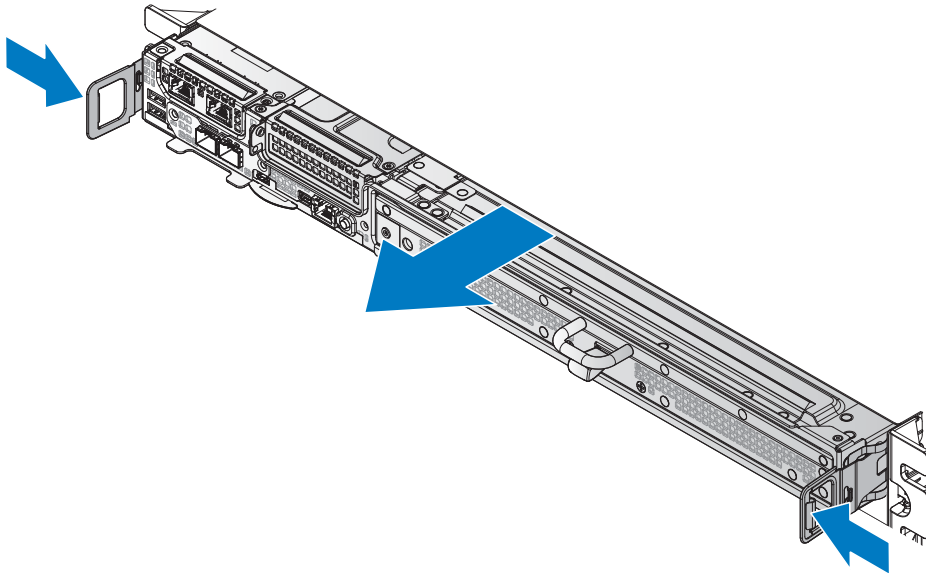

Figure 53. Removing the full-width server

Installing full-width server

- 1 Align the server with the bay, and insert the server into the block.
- 2 Slide the server in until it is fully seated in the block.
The server locks in place after it is properly seated.

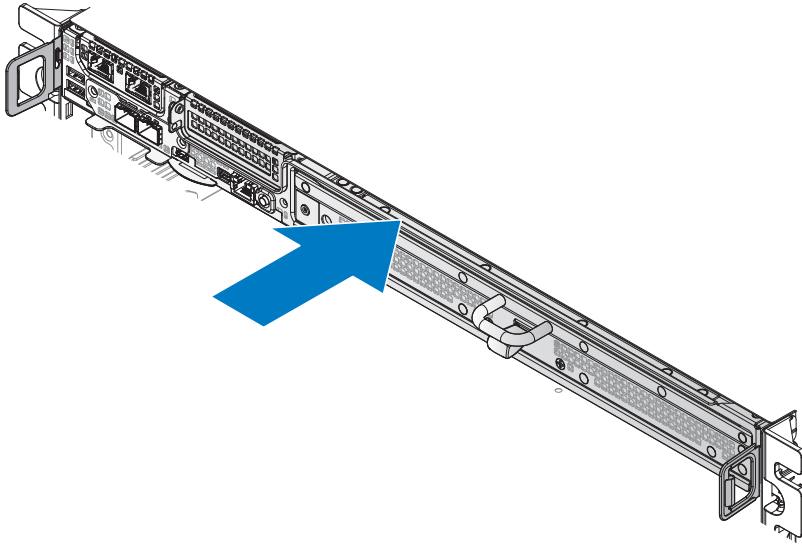

Figure 54. Installing the full-width server

Hard disk drive (HDD) trays

The HDD tray is only available for full width and JBOD servers.

Removing HDD tray

Prerequisites

- 1 Ensure that you read the Safety instructions.

Steps

- 1 Grasp the tray handle with one hand, and use your thumb to push the plunger up to release the HDD tray.
- 2 Continue to hold the plunger and use the tray handle to pull the tray out from the chassis.

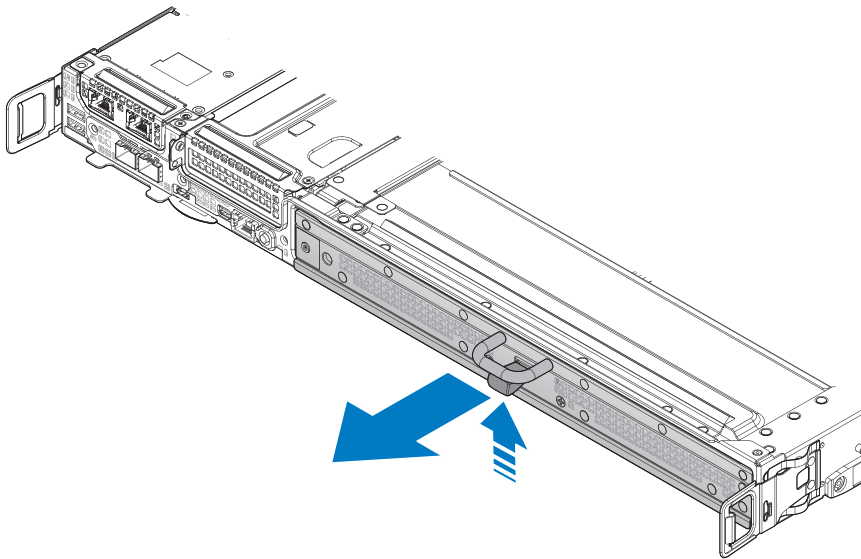

Figure 55. Releasing the HDD tray

- 3 Remove the HDD tray from the server.

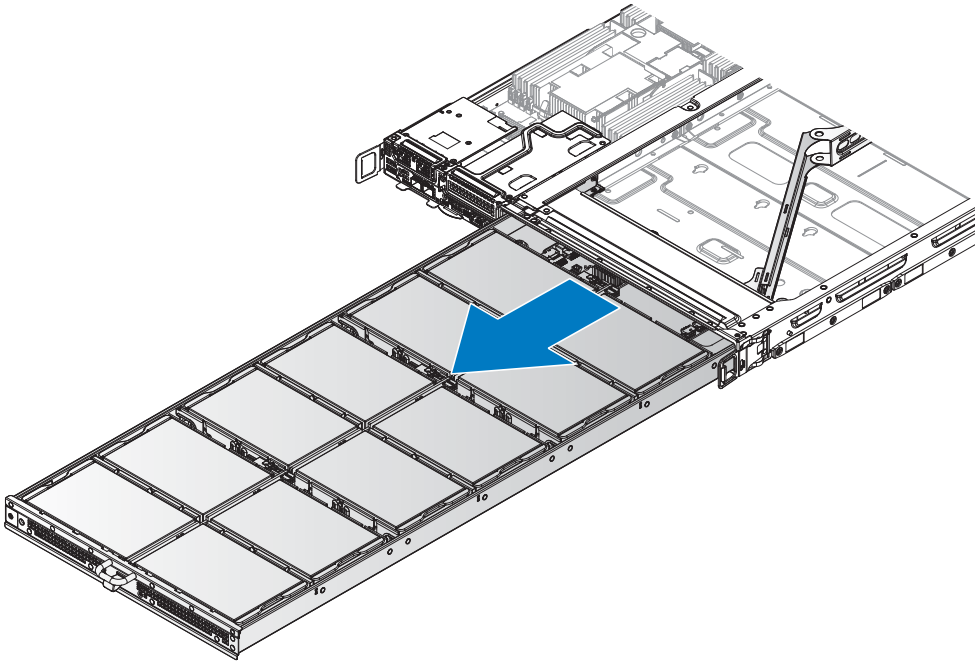

Figure 56. Removing the HDD tray

- 4 Remove all HDDs in the HDD tray.
- 5 Remove the screw and loosen the captive screw on the CMA.

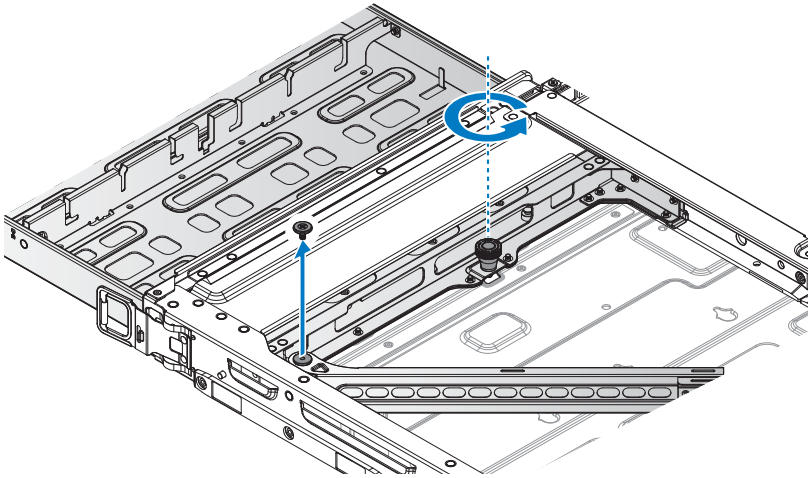

Figure 57. Unfastening the CMA

- 6 Continue to pull out the HDD tray and remove it completely from the chassis.

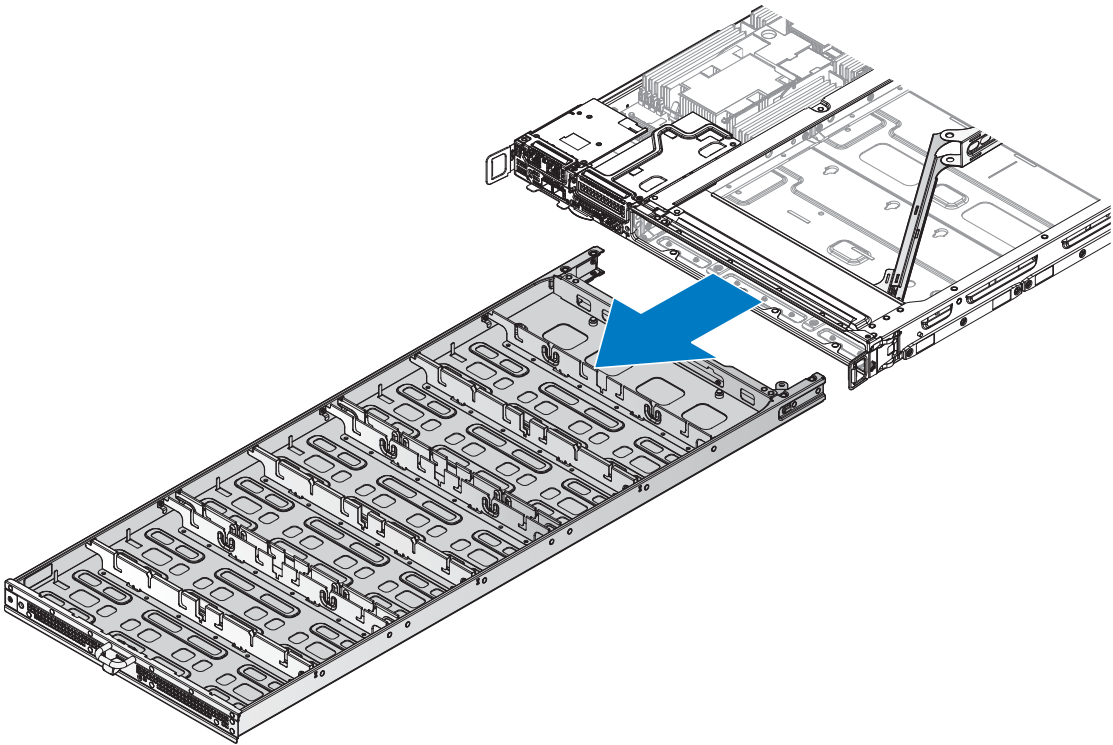

Figure 58. Removing the HDD tray from the server

Installing HDD tray

- 1 Insert the HDD tray into the server bay until the HDD tray clears the plunger.

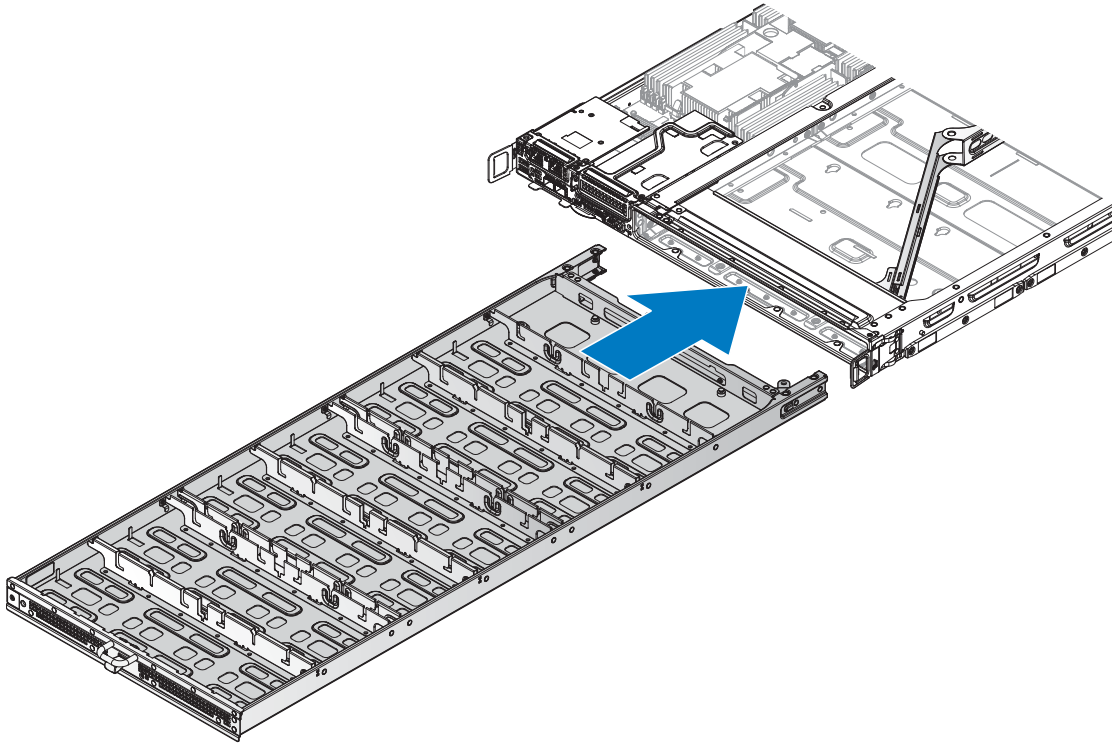

Figure 59. Installing the HDD tray

- 2 Align the CMA in the server making sure the screw wells on the CMA and server are aligned.
- 3 Insert a screw in the CMA and tighten it to secure it to the server.
- 4 Tighten the captive screw on the CMA.

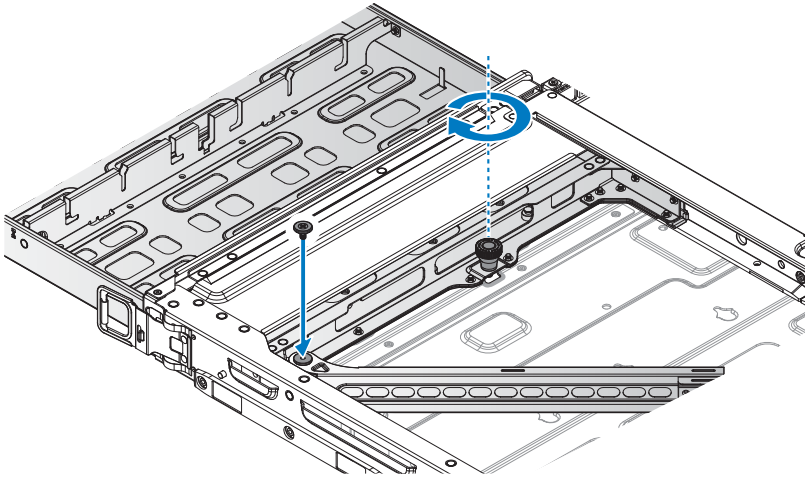

Figure 60. Securing the HDD tray and CMA

Table 35. Assembly material

Description	Quantity	Torque (lbs/inch)
#6-32 screw	1	8 ± 0.5

- 5 Install the HDDs on the HDD tray.
- 6 Push the HDD tray in until it is fully seated in the chassis.
The HDD tray locks in place after it is properly seated.

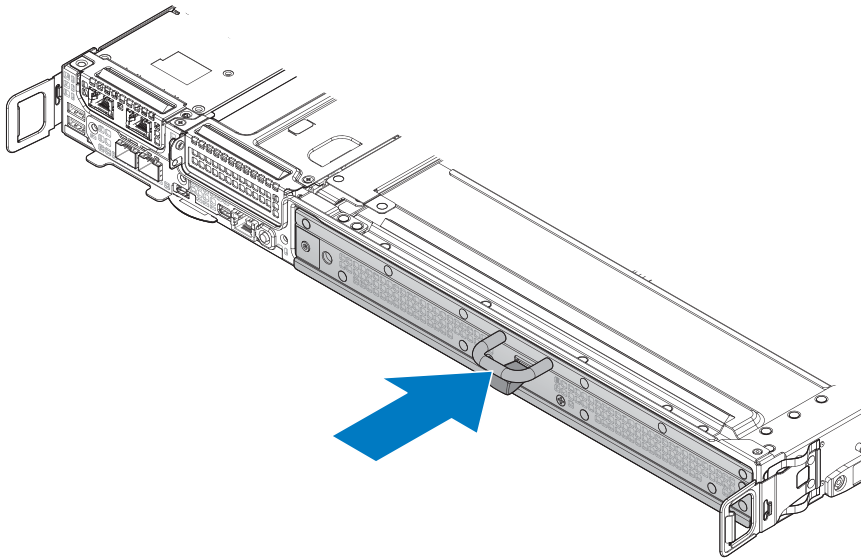

Figure 61. Installing the HDD tray

- 7 Install the full width server. For more details, see [Installing full-width server](#).

Power supply units (PSU)

Removing PSU

Prerequisites

- 1 Ensure that you read the Safety instructions.

Steps

- 1 Press down the PSU release latch.
- 2 Remove the PSU from the power bay.

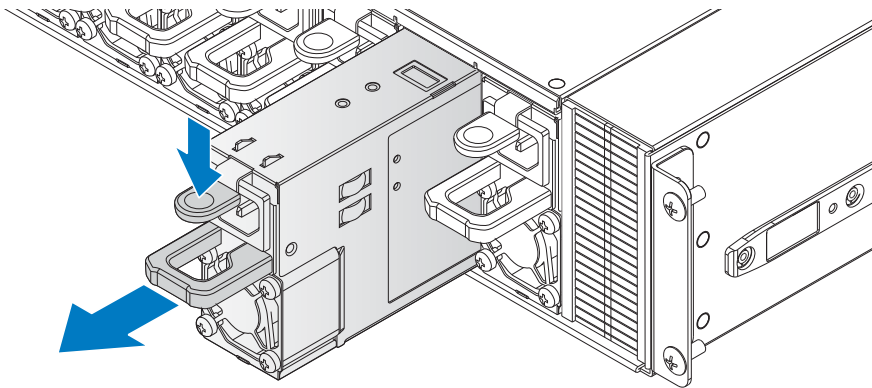

Figure 62. Removing the PSU

Installing PSU

- 1 Align the PSU with the bay. Make sure the connectors are positioned correctly before sliding the PSU into the bay.
- 2 Insert the PSU in the power bay and push it in until it is properly seated.
The PSU is secured when the release latch locks in place.

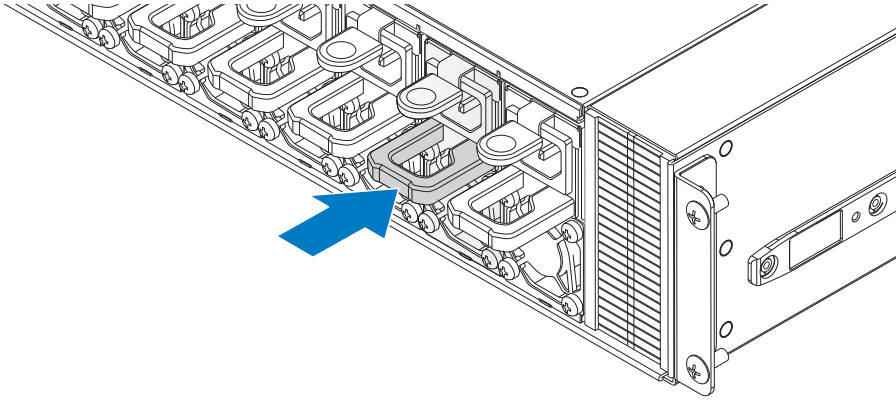

Figure 63. Installing the PSU

Fan modules

Removing fan module

⚠ CAUTION: To prevent damage to the system, remove only a single fan module at a time.

Prerequisites

- 1 Ensure that you read the Safety instructions.

Steps

- 1 Press up and hold the fan module release latch.
- 2 Pull the fan module out.
- 3 Remove the fan module from the fan cage.

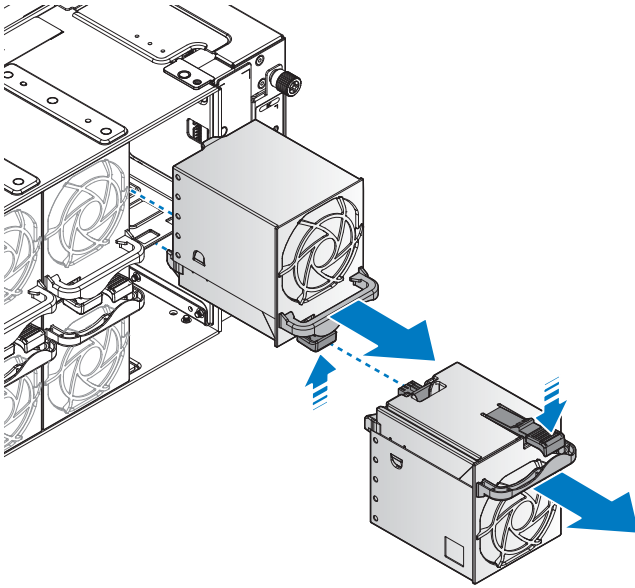

Figure 64. Removing the fan module

Installing fan module

- 1 Align the fan module with the fan cage, making sure the connectors are aligned.
- 2 Insert the fan module in the fan cage.
The fan module locks in the fan cage.

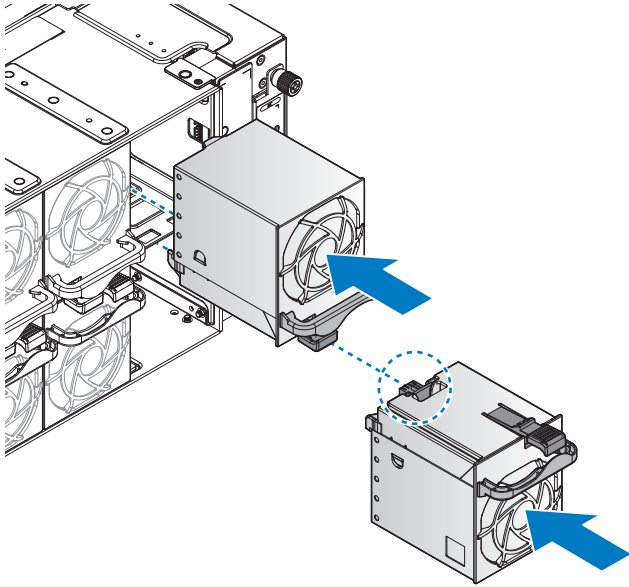

Figure 65. Installing the fan module

Fan blocks

Removing fan block

Prerequisites

- 1 Ensure that you read the Safety instructions.

Steps

- 1 Loosen the thumb screws.
- 2 Remove the fan block.

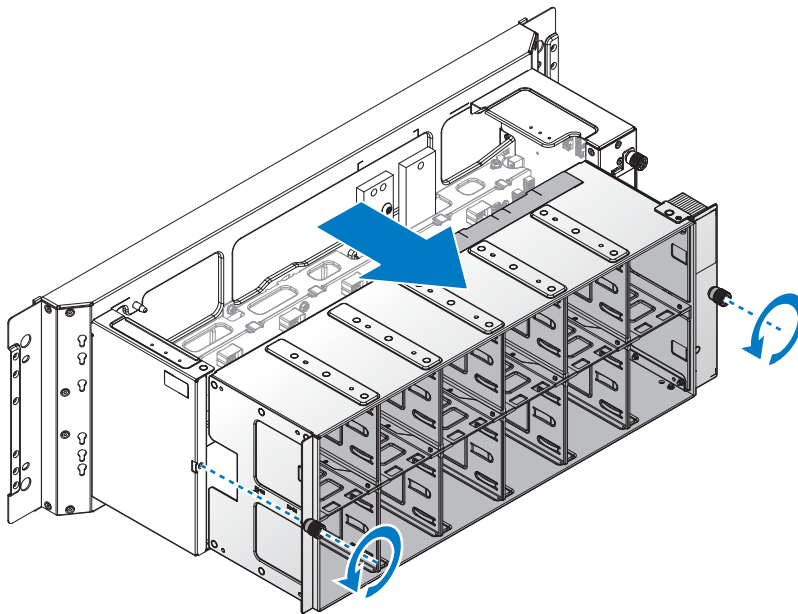

Figure 66. Removing the fan block

Installing fan block

- 1 Align the fan block with the FPDB.
- 2 Insert the fan block in the FPDB until the until slots are completely inserted into the connectors.
- 3 Tighten the thumb screws to secure the fan block.

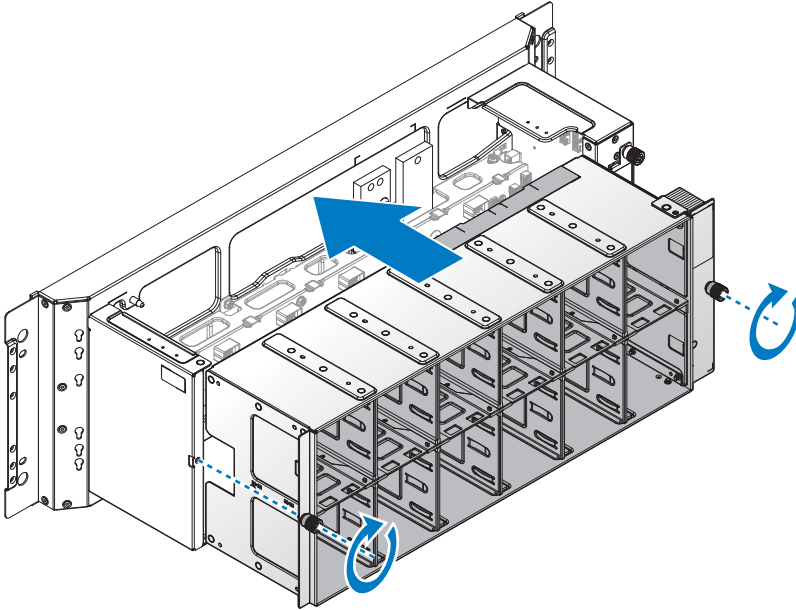

Figure 67. Installing the fan block

Fan power distribution boards (FPDB)

Removing FPDB

Prerequisites

- 1 Ensure that you read the Safety instructions.
- 2 Remove the fan block.

Steps

- 1 Disconnect the cables from the cable clip.
- 2 Disconnect the cables.

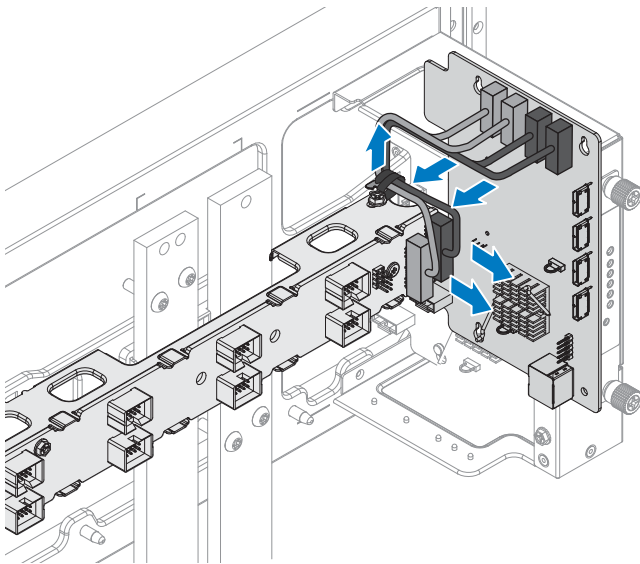

Figure 68. Disconnecting the FPDB cables

- 3 Remove the screws securing the FPDB.
- 4 Remove the FPDB.

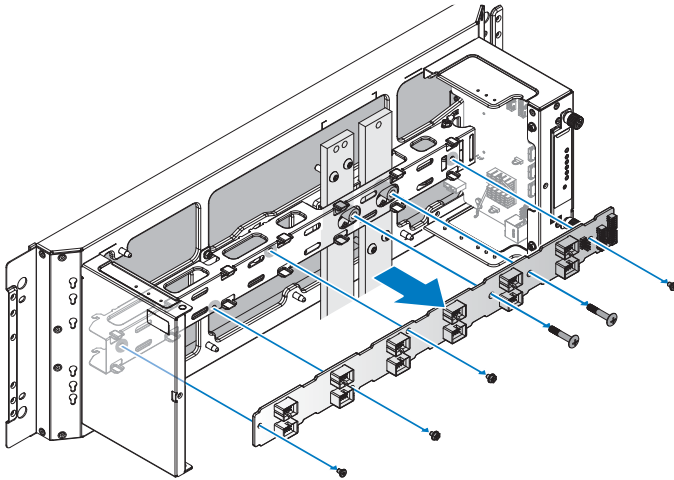

Figure 69. Removing the FPDB

Installing FPDB

- 1 Align the FPDB with the fan board bracket and install. Make sure the connectors are facing outward as seen in the following figure.
- 2 Secure the FPDB with screws.

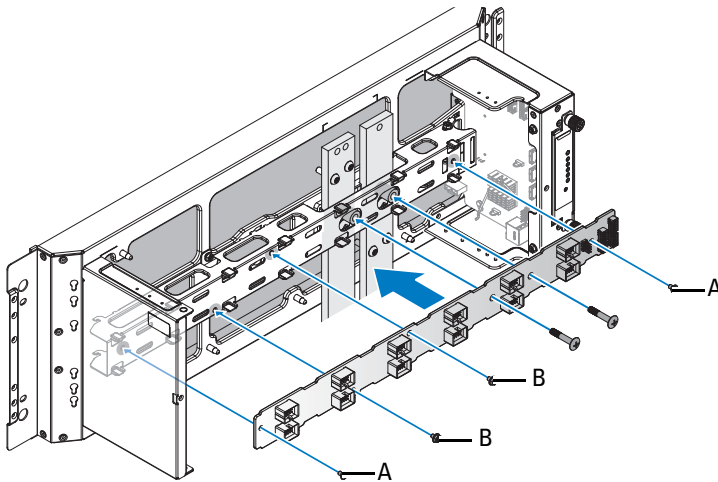

Figure 70. Installing the FPDB

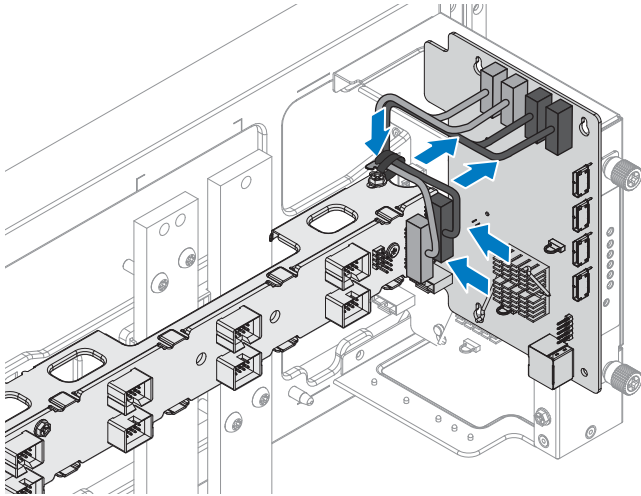

Figure 72. Securing a cable with a cable clip

Block Controller Distribution Board (BCDB)

Removing BCDB

Prerequisites

- 1 Ensure that you read the Safety instructions.
- 2 Remove block controller (BC).
- 3 Remove the fan block.

Steps

- 1 Disconnect the cables from the BCDB. Do not disconnect the HTPB cable at this time.

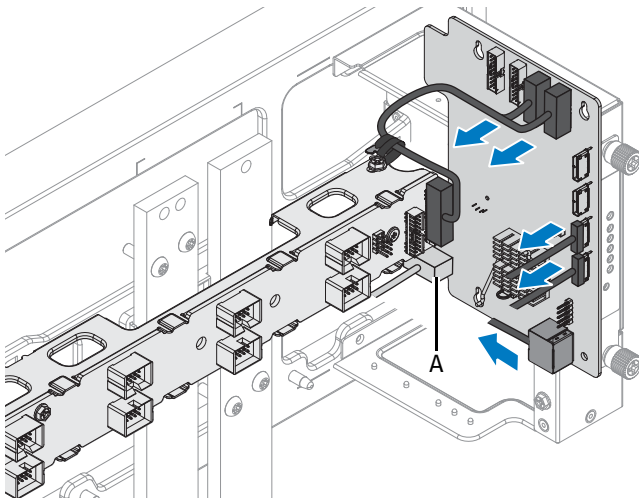

Figure 73. Disconnecting cables from a BCDB

A HTPB cable connector

- 2 Locate the screw securing the BCDB to the rear cabinet and remove it.
- 3 Slide the BCDB up to disengage from the posts on the rear cabinet.

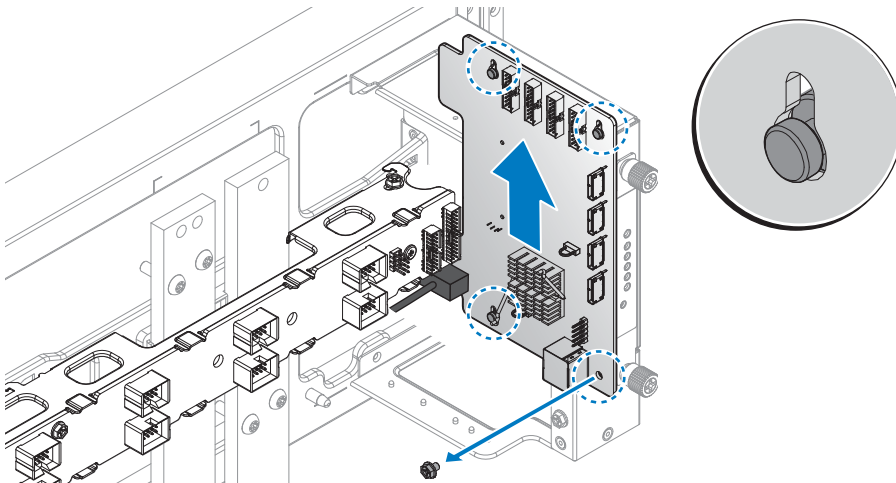

Figure 74. Disengaging the BCDB

- 4 Rotate the front of the BCDB until it clears the rear cabinet. Make sure the BCDB does not come in contact with the FPDB to prevent accidental damage to either component.
- 5 Once it is clear, slide the BCDB out until the HTPB cable is accessible. Do not remove the BCDB completely at this time.
- 6 Remove the BCDB from the rear cabinet cage.
- 7 Disconnect the HTPB cable from the BCDB.

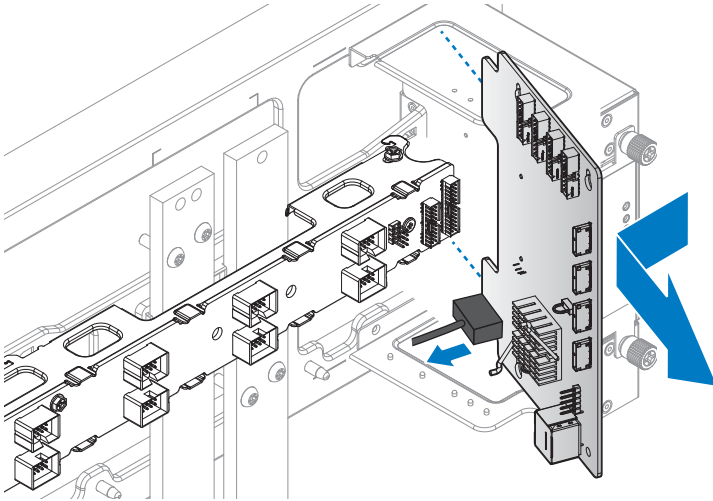

Figure 75. Disconnecting an HTPB cable and removing a BCDB

Installing BCDB

- 1** Position the BCDB so that the cable connectors face the FPDB.
- 2** Locate the HTPB connector at the bottom left of the BCDB and connect the HTPB cable.
- 3** Angle the rear of the BCDB so that it can be inserted behind the FPDB until it is seated in the rear cabinet cage. During the course of the installation, make sure the BCDB does not come in contact with the FPDB assembly to prevent damage to either component.
- 4** Rotate the front of the BCDB towards the rear cabinet. Make sure the keyholes on the BCDB are aligned with the posts on the rear cabinet cage.

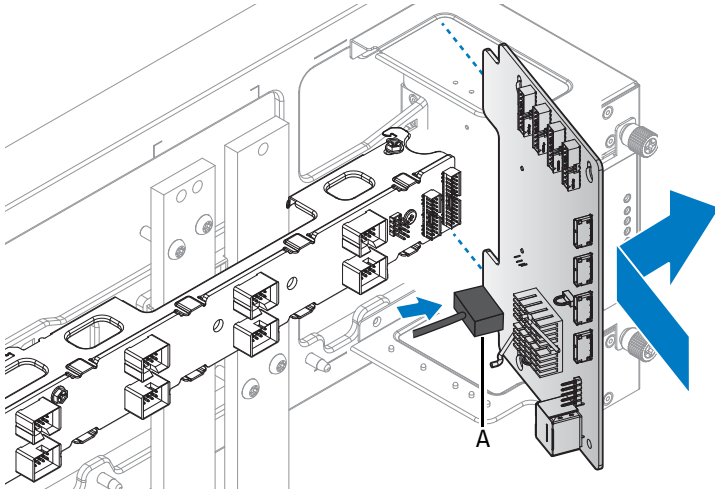

Figure 76. Connecting an HTPB cable and installing a BCDB

A HTPB cable connector

- 5 Once the BCDB is seated in the rear cabinet cage, slide it down to engage the posts through the keyholes. All three posts are must be visible through the keyholes to ensure the BCDB is properly seated.
- 6 Secure the BCDB with the screw.

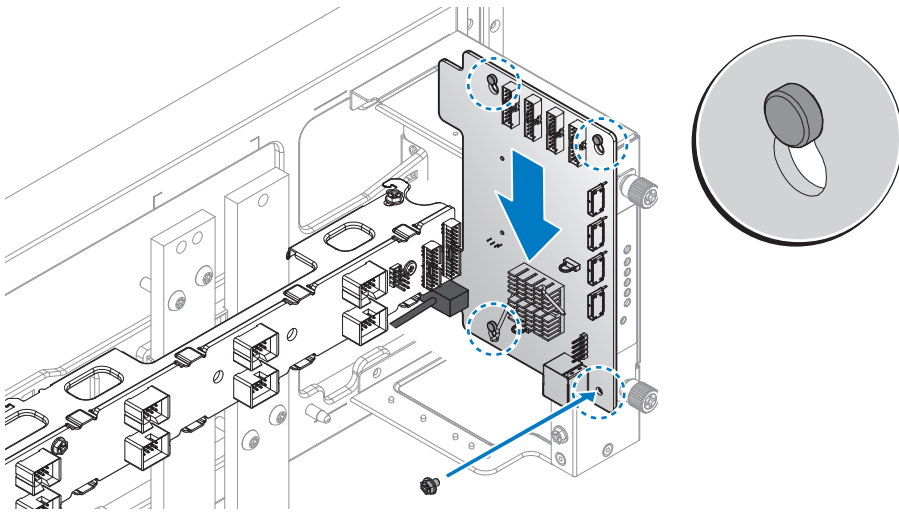

Figure 77. Engaging the BCDB in the rear cabinet cage

- 7 Connect the cables to the connectors on the BCDB.

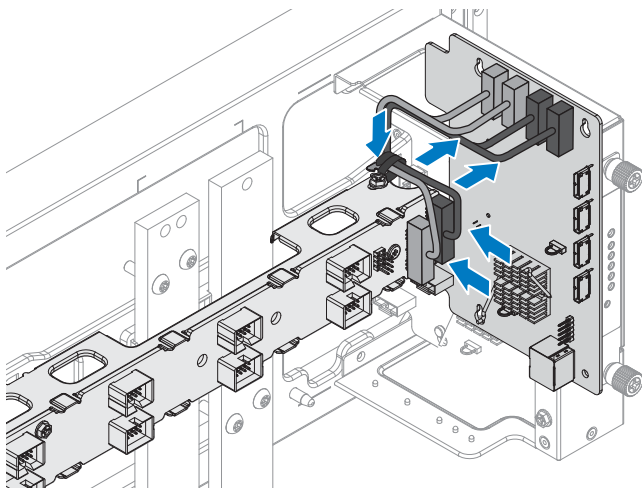

Figure 78. Connecting cables on the BCDB

Block controllers (BC)

Removing BC

Prerequisites

- 1 Ensure that you read the Safety instructions.

Steps

- 1 Loosen the captive screws on the BC.
- 2 Remove the BC from the cage.

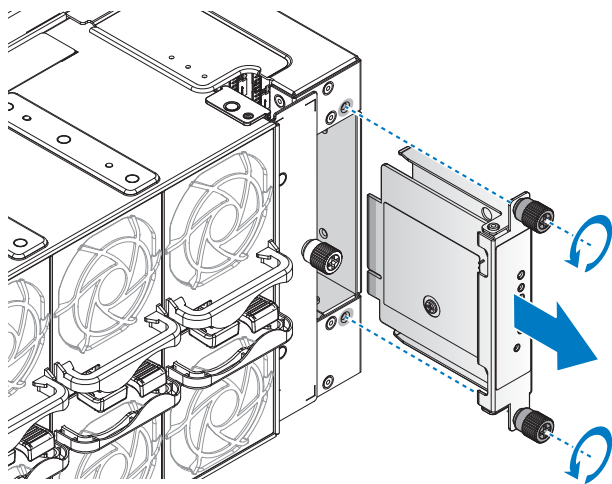

Figure 79. Removing the BC

Installing BC

- 1 Align the connector on the BC with the bay in the cage.
- 2 Slide the BC into the rear cabinet until it is flush with the cage.
- 3 Tighten the captive screws to secure the module to the rear cabinet.

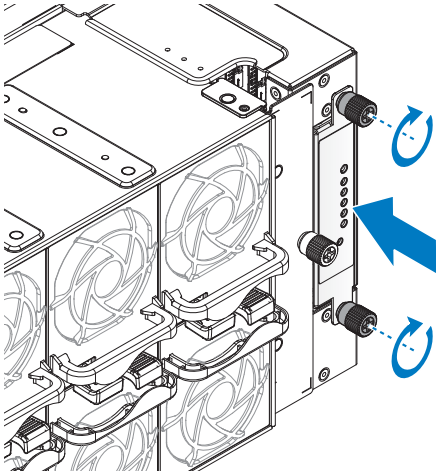

Figure 80. Installing the BC

Management controllers (MC)

Removing MC

Prerequisites

- 1 Ensure that you read the Safety instructions.

Steps

- 1 Press down on the MC release latch.
- 2 Remove the MC from the power bay.

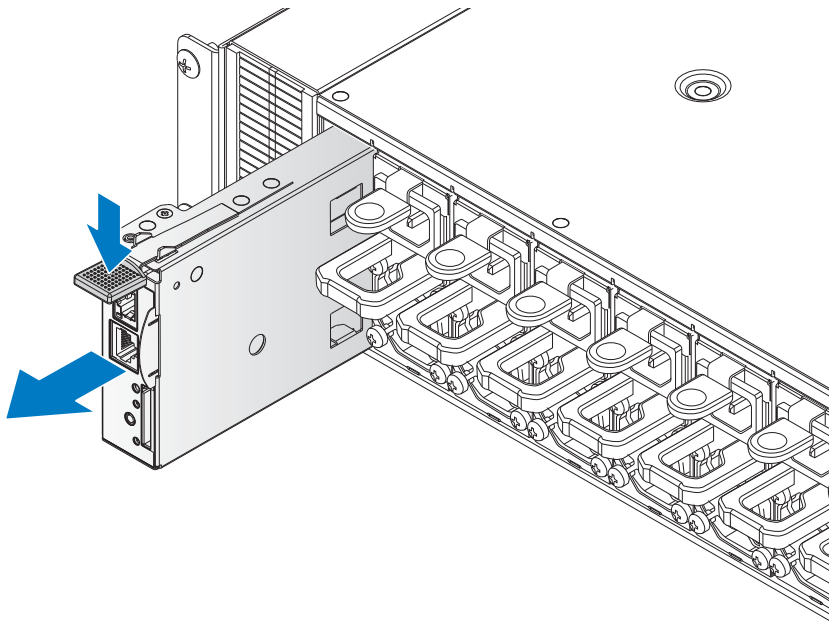

Figure 81. Removing the MC

Installing MC

- 1 Align the MC with the bay. Make sure the connector is positioned correctly before inserting into the bay.
- 2 Insert the MC in the bay and slide it in until it is flush with the bay.

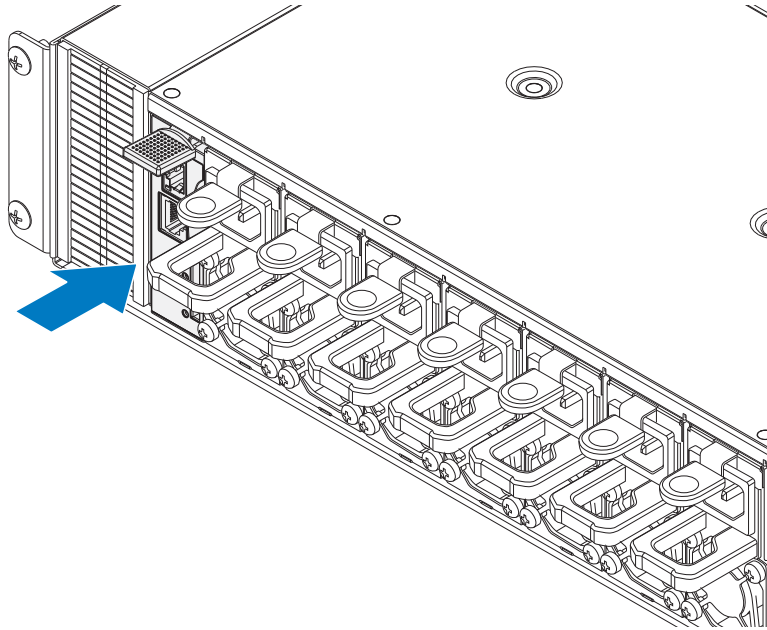

Figure 82. Installing the MC

Rack manager board (RMB) and infrastructure module (IM)

Removing DSS 9000 rack manager module

Prerequisites

- 1 Ensure that you read the Safety instructions.

Steps

- 1 Loosen the captive screws securing the rack manager module to the power bay.
- 2 Grasp the rack manager module and slide it out of the power bay.

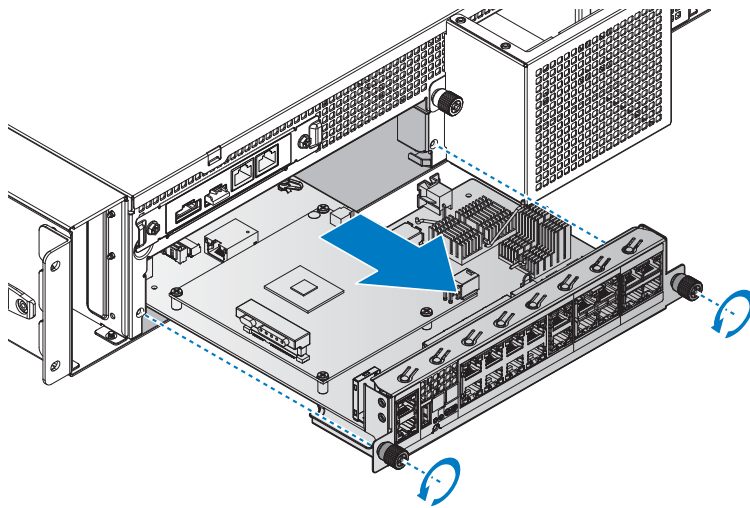

Figure 83. Removing the DSS 9000 rack manager module

Installing DSS 9000 rack manager module

- 1 Align the rack manager module with the power bay.
- 2 Slide the rack manager module into the bay until it is flush in the power bay.
- 3 Turn the captive screws to secure the rack manager module to the power bay.

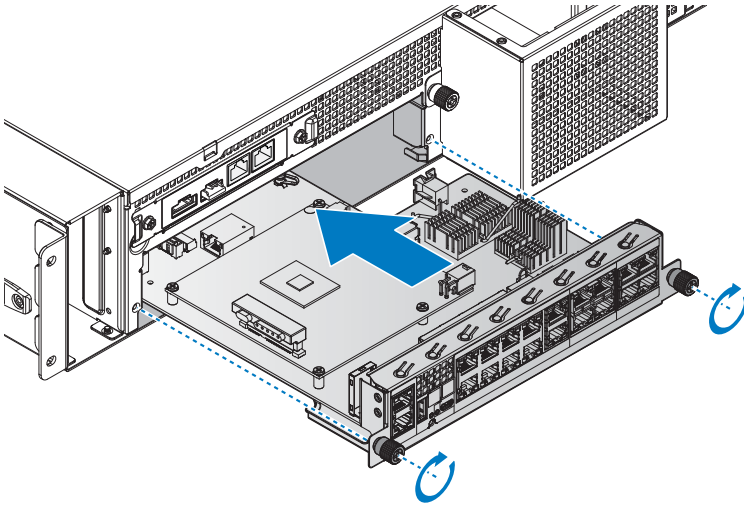

Figure 84. Installing the DSS 9000 rack manager module

Removing IM

Prerequisites

- 1 Ensure that you read the Safety instructions.
- 2 Remove the rack manager module from the power bay, see "Removing DSS 9000 rack manager module" on page 71.

Steps

- 1 Remove the screws securing the IM to the bracket.
- 2 Hold the IM by the sides and lift it out to separate from the bracket.

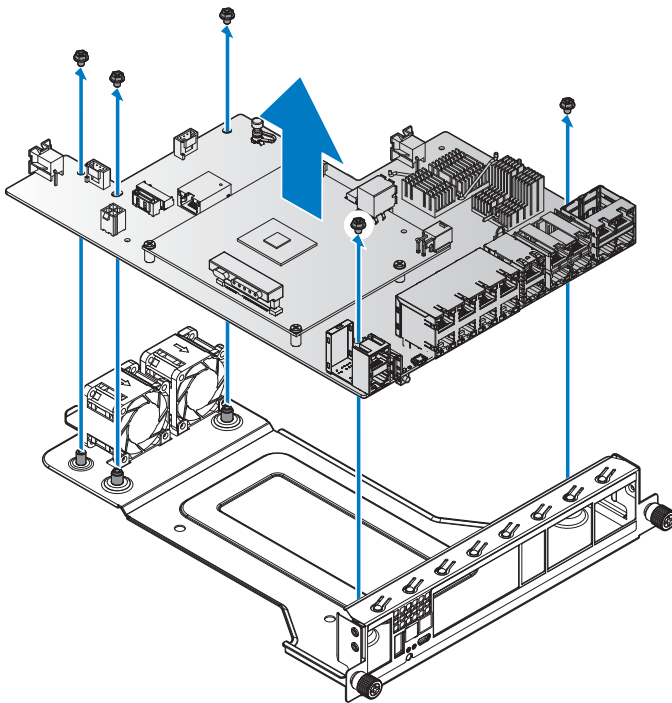

Figure 85. Separating the IM from the bracket

Installing IM

- 1 Grasp the IM by the edges and align it in the bracket.
- 2 Lower it in place and make sure the screw holes on the bracket and IM are aligned.
- 3 Secure the IM to the bracket with the screws.

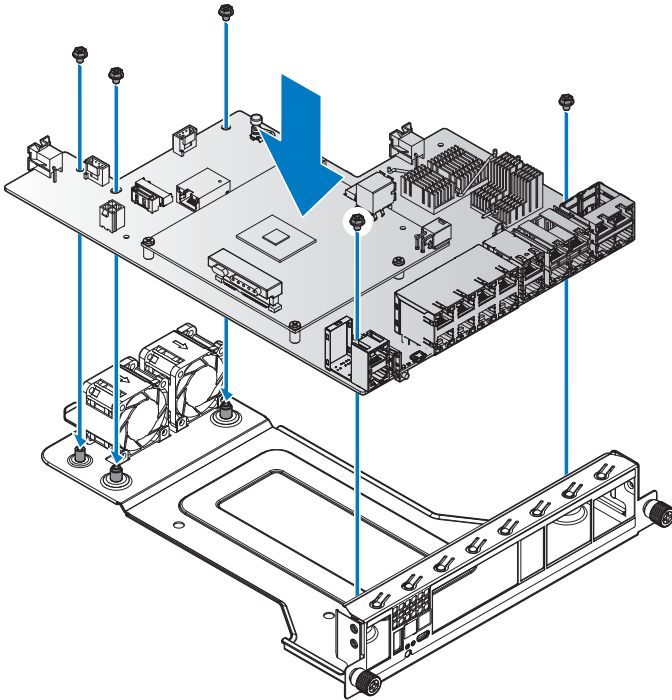

Figure 86. Assembling the IM and bracket

Next steps

- 1 Install the rack manager module.

Rear IO modules

Removing rear IO module

Prerequisites

- 1 Ensure that you read the Safety instructions.

Steps

- 1 Remove the screws from the rear IO.
- 2 Remove the rear IO from the power bay.

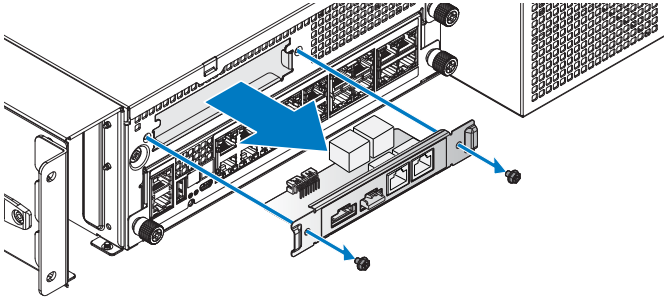

Figure 87. Removing the rear IO module

Installing rear IO module

- 1 Insert the rear I/O into the power bay.
- 2 Secure the rear I/O to the power bay with screws.

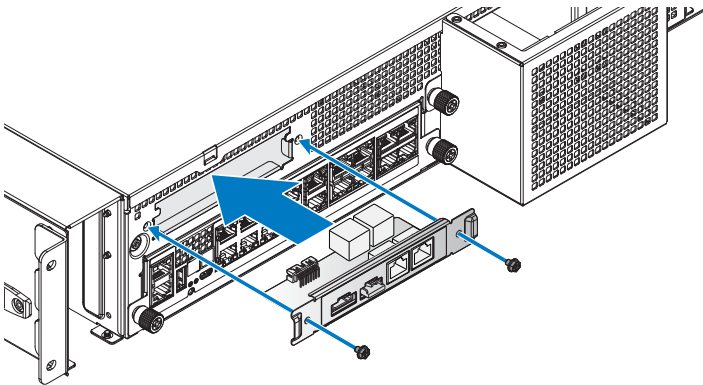

Figure 88. Installing the rear IO module

Table 37. Assembly material

Description	Quantity	Torque (lbs/inch)
#6-32 screw	2	8 ± 0.5

Power interface board (PIB)

Removing PIB

⚠ CAUTION: Many repairs may only be done by a certified service technician. You should only perform troubleshooting and simple repairs as authorized in your product documentation, or as directed by the online or telephone service and support team. Damage due to servicing that is not authorized is not covered by warranty. Read and follow the safety instructions that came with the product.

Before attempting to service any part of the Power Interface Board (PIB), make sure the power source and power cables are turned off and disconnected.

It is not necessary to remove the PIB cover. The following procedure is provided as reference information only.

Prerequisites

- 1 Ensure that you read the Safety instructions.

Steps

- 1 Make sure the system is turned off. Log in to the interface. The command line interface (CLI) is displayed.
- 2 Change directory locations to the specified directory as shown in the following figure.
- 3 Type the command **stop** to turn off the system. The turn-off process is fully completed in 2 minutes.

```
/DEVICEHANAGER/RACK1/BLOCK1/BC-> cd ..  
/DEVICEHANAGER/RACK1/BLOCK1-> cd ..  
/DEVICEHANAGER/RACK1/->  
/DEVICEHANAGER/RACK1/->  
/DEVICEHANAGER/RACK1/->  
/DEVICEHANAGER/RACK1/->  
/DEVICEHANAGER/RACK1/->  
/DEVICEHANAGER/RACK1/->  
/DEVICEHANAGER/RACK1/-> stop
```

Figure 89. Turning off the system

- 4 After the system is fully turned off, disconnect the respective power cables from the electrical sockets before proceeding further.
- 5 Remove the server modules from the block chassis. For more details, see Servers.
- 6 Remove the securing screws attached to the chassis ears.
- 7 Remove the securing screws attached to the cross bus bars and main bus bars.

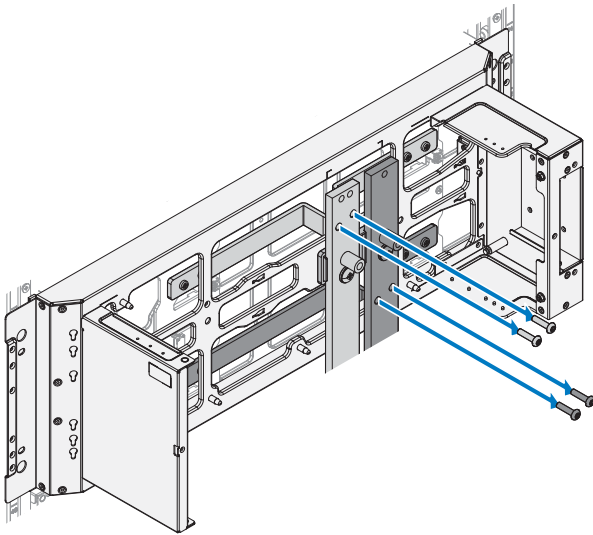

Figure 90. Removing the bus bar screws

- 8 The block chassis is no longer secured to the rack cabinet.

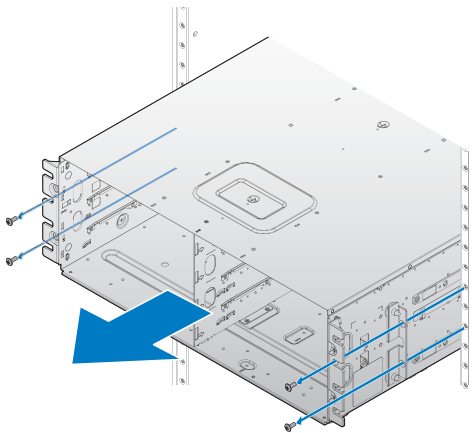

Figure 91. Removing the block chassis from the rack cabinet

- 9 Remove the block chassis from the rack cabinet and place it on a clean work surface.
- 10 Locate the rear of the block chassis. The cross bus bar (x2) and PIBs (x2) are visible from the rear view.
- 11 Remove the screws securing the cross bus bar to the chassis.

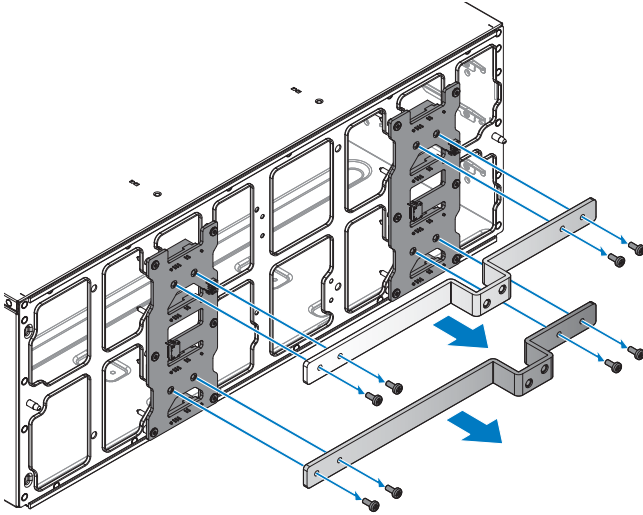

Figure 92. Removing the cross bus bars

- 12 Remove the bus bars and place them on a clean surface.
- 13 Remove the screws securing the PIBs to the chassis.

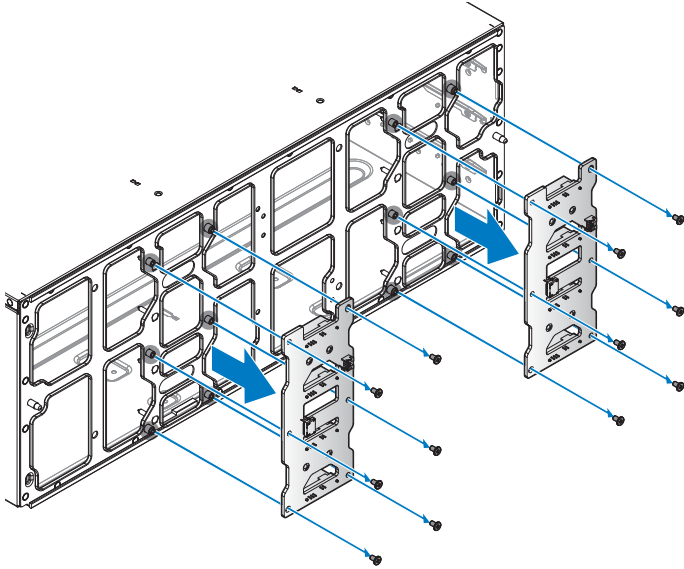

Figure 93. Removing PIBs

- 14 Remove the PIBs and place them on a clean surface.

Installing PIB

⚠ CAUTION: Many repairs may only be done by a certified service technician. You should only perform troubleshooting and simple repairs as authorized in your product documentation, or as directed by the online or telephone service and support team. Damage due to servicing that is not authorized is not covered by warranty. Read and follow the safety instructions that came with the product.

Before attempting to service any part of the Power Interface Board (PIB), make sure the power source and power cables are turned off and disconnected.

To install the PIB:

The following procedure is provided as reference information only.

- 1 Make sure the system is turned off before proceeding.
If the system is not turned off, do the following:
 - A. Log in to the interface. The CLI is displayed.
 - B. Change directory locations to the specified directory as shown in the following figure.
 - C. Type the command **stop** to turn off the system. The turn-off process is fully completed in 2 minutes.

```
/DEVICEHANAGER/RACK1/BLOCK1/BC-> cd ..  
/DEVICEHANAGER/RACK1/BLOCK1-> cd ..  
/DEVICEHANAGER/RACK1/->  
/DEVICEHANAGER/RACK1/->  
/DEVICEHANAGER/RACK1/->  
/DEVICEHANAGER/RACK1/->  
/DEVICEHANAGER/RACK1/->  
/DEVICEHANAGER/RACK1/->  
/DEVICEHANAGER/RACK1/-> stop
```

Figure 94. Turning off the system

After the system is fully turned off, disconnect the respective power cables from the electrical sockets before proceeding further.

- 2** Locate the rear of the block chassis.
- 3** Remove the new PIBs from their packaging content and inspect for damage.
- 4** Align the PIBs on each respective location, see the following figure for further details, and place them on the block chassis.
- 5** Secure the PIBs to the chassis with the provided screws.

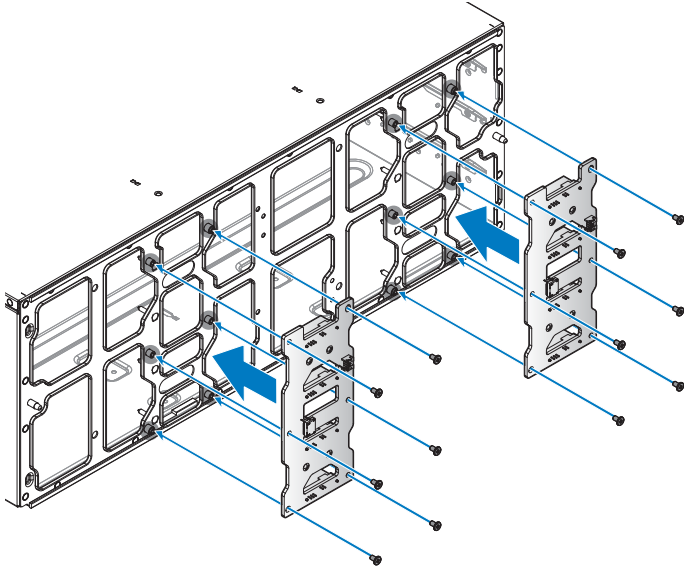

Figure 95. Installing PIBs

Table 38. Assembly material

Description	Quantity	Torque (lbs/inch)
#6-32 screw	12	8 ± 0.5

- 6** Align the top cross bus bar (positive, red) with the PIBs. Make sure the holes on the cross bus bar align with the holes on the PIBs.
- 7** Secure the cross bus bar and PIBS to the chassis with the provided screws.
- 8** Repeat for the bottom cross bus bar (negative, black).

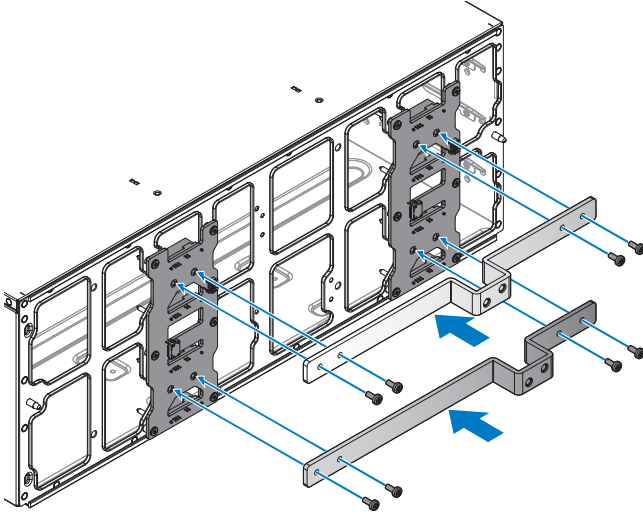

Figure 96. Installing cross bus bars

Table 39. Assembly material

Description	Quantity	Torque (lbs/inch)
M4 screw	8	8 ± 0.5

- 9** Align the block chassis with the rack cabinet and slide in place until the securing ears are flush with the rack posts.
- 10** Secure the block chassis to the posts with the provided screws.

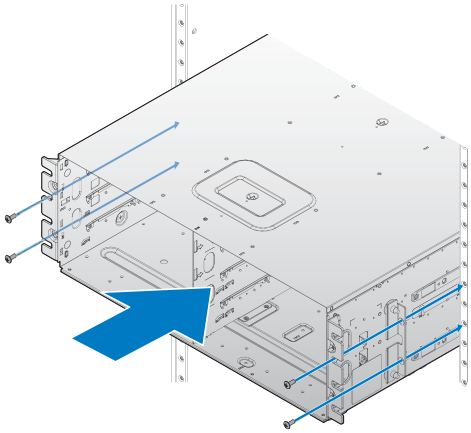

Figure 97. Installing the block chassis on the rack cabinet

Table 40. Assembly material

Description	Quantity	Torque (lbs/inch)
M5 screw	4	18 ± 1

- 11** Install the server modules on the block chassis. For more details, see Servers.
- 12** Secure the cross bus bars and main bus bars with the provided screws.

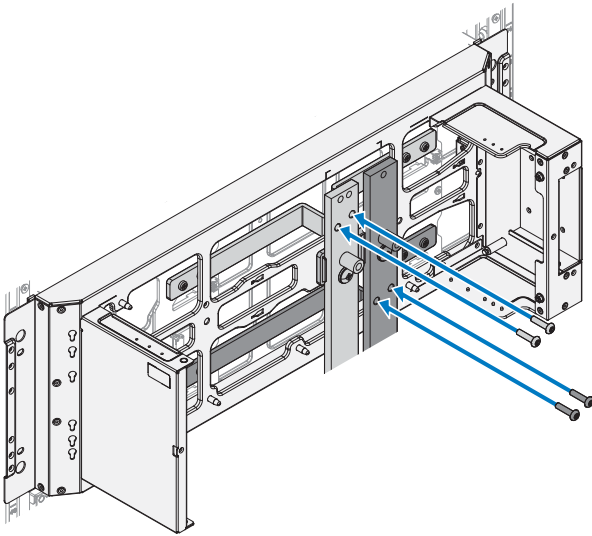

Figure 98. Securing bus bars

Table 41. Assembly material

Description	Quantity	Torque (lbs/inch)
M5 screw	4	16 ± 1

Troubleshooting

Troubleshooting list

Table 42. Troubleshooting list

Issue description	Trigger event for amber LED (MC/IM/BC)	Root cause	Troubleshooting step
Fan fail (keeps 100% duty)			<ol style="list-style-type: none"> 1 Check HTPB. 2 Check G5.5 FW version in IM/MC/BC. 3 Check "llcDebug" command.
BC Power LED amber	<ul style="list-style-type: none"> • For I²C communication and MOSFET failure, BC dumps EEPROM log. • For FPGA configuration failed, BC may rebooting again and again. 	<ol style="list-style-type: none"> 1 MAC address missed or incorrect. 2 Ethernet link is down. 3 Wrong fan table file. 4 FPGA image is wrong. 5 FPGA configuration failed. 6 Mosfet failed. 7 I²C communication failed. 	<ol style="list-style-type: none"> 1 Ensure fan table and FPGA image s correct. 2 LAN connection is fine. 3 Ensure MAC address is correct and present. 4 Ensure there is no HW damage.
Fan Zone 1 fail LED amber	<ul style="list-style-type: none"> • If 1 fan fails, BC will move to fan table C. • If 2 fan fails, BC will move to fan table D and fan will rotate on 100% PWM. 	1 or more than 1 fans become absent from left group of 6 fans (fan no: 1~6).	Ensure all fans insert in fan wall properly.
Fan Zone 2 fail LED amber	<ul style="list-style-type: none"> • If 1 fan fails, BC will move to fan table C. • If 2 fan fails, BC will move to fan table D and fan will rotate on 100% PWM. 	1 or more than 1 fans become absent from right group of 6 fans (fan no: 7~12).	Ensure all fans insert in fan wall properly.

Table 42. Troubleshooting list (continued)

Issue description	Trigger event for amber LED (MC/IM/BC)	Root cause	Troubleshooting step
IM status LED amber		<ol style="list-style-type: none"> 1 MAC address missed or incorrect. 2 I²C communication fail. 	<ol style="list-style-type: none"> 1 Set MAC address using llcDebug command if its incorrect or missed. 2 Ensure there is no HW damage.
BC status LED blinking amber	LED will blink on every 1s interval and 'LastUpgradeStatus' property on Bc target will show CFGERROR.	Different Infrastructure property between BC and MC (G5/G5.5).	Ensure both BC and MC have same Infrastructure property.
IM status LED blinking amber	LED will blink on every 1s interval and 'LastUpgradeStatus' property on IM target will show CFGERROR.	Different Infrastructure property between IM and MC (G5/G5.5).	Ensure both IM and MC have same Infrastructure property.
MC Error LED blinking amber	LED will blink on every 1s interval and 'LastUpgradeStatus' property on Rack target will show CFGERROR.	Different Infrastructure property between IM, MC and BC (G5/G5.5).	Ensure IM, MC and BC have same Infrastructure property.
MC Error LED amber	MC will dump log in llcEvent.log file.	Ethernet link to IM is down.	Ensure LAN connection is fine.
PSU status LED amber	MC will send PSU fault bitmap to iDRAC through BC and MC will display PSU Error status on MC CLI under PSU target.	PSU fail.	OCP, OVP, OTP.
G5.5 FW update fail	BC/IM will send fail status to MC and MC will dump the llcEvents log (BC/IM will not lit Amber LED).	Any image is wrong (header/checksum) or update G5 image on G5.5.	<ol style="list-style-type: none"> 1 Call Dell help. Ask if the FW is official release.
Some server can not boot after rack power on			<ol style="list-style-type: none"> 1 Reset server.

Getting help

Contacting Dell

Dell provides several online and telephone based support and service options. If you do not have an active internet connection, you can find contact information about your purchase invoice, packing slip, bill, or Dell product catalog. Availability varies by country and product, and some services may not be available in your area. To contact Dell for sales, technical assistance, or customer service issues:

- 1** Go to [Dell.com/support](https://www.dell.com/support).
- 2** Select your country from the drop-down menu on the lower right corner of the page.
- 3** For customized support:
 - a** Enter your system Service Tag in the **Enter your Service Tag** field.
 - b** Click **Submit**.
The support page that lists the various support categories is displayed.
- 4** For general support:
 - a** Select your product category.
 - b** Select your product segment.
 - c** Select your product.
The support page that lists the various support categories is displayed.
- 5** For contact details of Dell Global Technical Support:
 - a** Click **Global Technical Support**.
 - b** The **Contact Technical Support** page is displayed with details to call, chat, or e-mail the Dell Global Technical Support team.

Documentation feedback

You can rate the documentation or write your feedback on any of our Dell documentation pages and click **Send Feedback** to send your feedback.