

# Dell EMC DSS 9000J Servers Installation and Service Manual

Regulatory Model: B08B Series  
Regulatory Type: B08B002



## Notes, cautions, and warnings



**NOTE:** A NOTE indicates important information that helps you make better use of your system.



**CAUTION:** A CAUTION indicates a potential for damage to hardware or loss of data if instructions are not followed.



**WARNING:** A WARNING indicates a potential for property damage, personal injury, or death.

Copyright © 2017 Dell Inc. or its subsidiaries. All rights reserved. Dell, EMC, and other trademarks are trademarks of Dell Inc. or its subsidiaries. Other trademarks may be trademarks of their respective owners.

2017 - 10

Rev. A00

# Contents

1	Overview . . . . .	1
	<b>System specifications . . . . .</b>	<b>2</b>
	HDD Indicator codes . . . . .	3
	<b>Locating your system service tag . . . . .</b>	<b>4</b>
2	Documentation resources . . . . .	5
3	Technical specifications . . . . .	7
	<b>Environmental specifications . . . . .</b>	<b>7</b>
	Temperature specifications . . . . .	7
	Relative humidity specifications . . . . .	7
	Maximum vibration specifications . . . . .	8
	Maximum shock specifications . . . . .	8
	Maximum altitude specifications . . . . .	8
	Operating temperature de-rating specifications . . . . .	9
	Particulate and gaseous contamination specifications . . . . .	9
	Standard operating temperature specifications . . . . .	10
	Expanded operating temperature specifications . . . . .	10
4	Installing and removing server components . . . . .	12
	<b>Safety instructions . . . . .</b>	<b>12</b>
	<b>Before working inside your system . . . . .</b>	<b>12</b>
	<b>After working inside your system . . . . .</b>	<b>13</b>
	<b>Recommended tools . . . . .</b>	<b>13</b>
	<b>Hard drive . . . . .</b>	<b>14</b>
	Removing 3.5-inch hard drive from a tray . . . . .	15
	Installing 3.5-inch hard drive into a tray . . . . .	19
	Removing 2.5-inch hard drive from a tray . . . . .	21
	Installing 2.5-inch hard drive into a tray . . . . .	25

<b>NPDB board</b> . . . . .	<b>28</b>
Removing NPDB . . . . .	28
Installing NPDB . . . . .	29
<b>Hard drive backplane</b> . . . . .	<b>31</b>
Removing HDD backplane . . . . .	31
Installing HDD backplane. . . . .	33
<b>SAS expander board</b> . . . . .	<b>35</b>
Removing SAS expander board . . . . .	35
Installing SAS expander board . . . . .	36
<b>Cable management arm component.</b> . . . . .	<b>37</b>
Removing CMA in a hard drive tray. . . . .	37
Installing CMA in a hard drive tray . . . . .	39
<b>5 Getting help</b> . . . . .	<b>42</b>
<b>Contacting Dell.</b> . . . . .	<b>42</b>
<b>Documentation feedback</b> . . . . .	<b>42</b>

# Overview

The DSS 9000J enclosure contains a full-width JBOD.

 **NOTE:** The product at time of delivery may differ from the following illustrations.

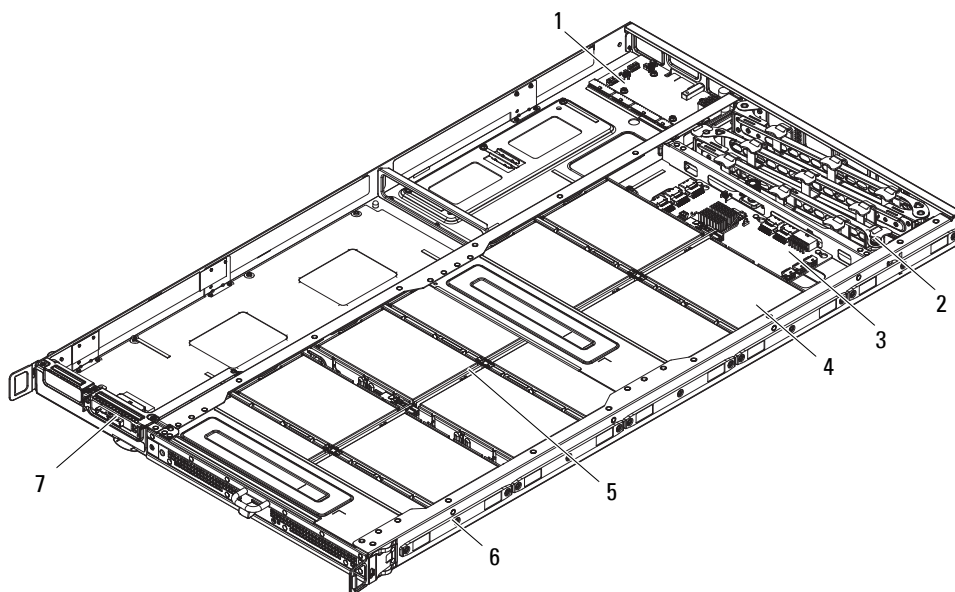

**Figure 1. DSS 9000J overview**

**Table 1. DSS 9000J overview description**

No.	Item	Description
1	NPDB	Node power distribution board.
2	Cable management arm	Optimizes data and power cabling usage.
3	SAS expander board	Controller card which allows the expansion of storage capacity. External connections are supported through a SAS cable.
4	Hot swap HDD bay	Supports twelve 3.5-inch or twelve 2.5-inch HDDs.
5	HDD backplane	Supports four HDD modules, each server contains three HDD backplanes.

**Table 1. DSS 9000J overview description (continued)**

No.	Item	Description
6	Sled chassis	Full width 1U chassis.
7	External SAS port	Through SAS port to connect to DSS 9600.

## System specifications

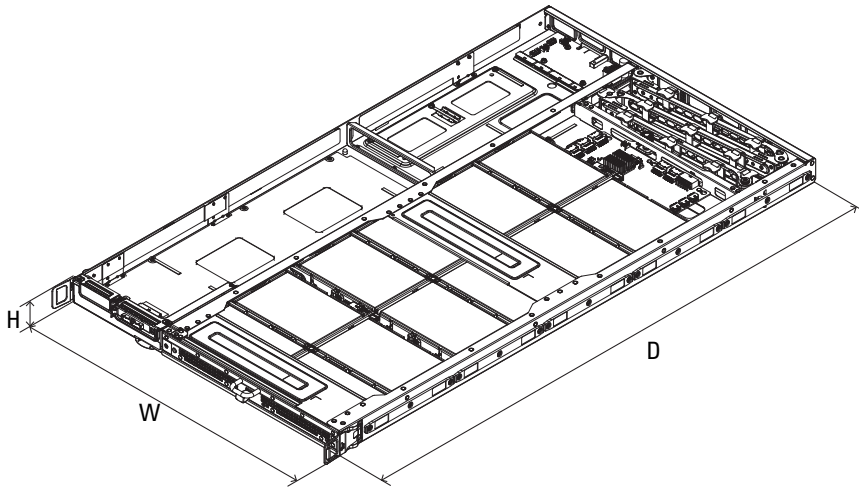

**Figure 2. DSS 9000J dimensions**

**Table 2. DSS 9000J dimensions**

Item	Description
Dimension (W x D x H)	527 mm x 930 mm x 47 mm (20.75 inch x 36.61 in x 1.85 inch)
Weight (fully loaded)	21.12 kg (46.56 lb)

## HDD Indicator codes

The expansion adapter has LED headers that correspond to access activity and link status.

### Broadcom 9300-4i4e

**Table 3. Broadcom 9300-4i4e**

LED state	HDD state	Green LED	Amber LED
1	Empty	Off	Off
2	Online	On	Off
3	Identify/Prepare for removal	Blinking	Off
4	Rebuild	NA	NA
5	Fault	On	Off

### Broadcom 9380-4i4e

**Table 4. Broadcom 9380-4i4e**

LED state	HDD state	Green LED	Amber LED
1	Empty	Off	Off
2	Online	On	Off
3	Identify/Prepare for removal	Blinking	Off
4	Rebuild	Blinking	Off
5	Fault	Off	Blinking

## Locating your system service tag

Your system is identified by a unique Express Service Code and Service Tag number. The Express Service Code and Service Tag are found on the front of the system by pulling out the information tag. Alternatively, the information may be on a sticker on the chassis of the system. This information is used by Dell to route support calls to the appropriate personnel.

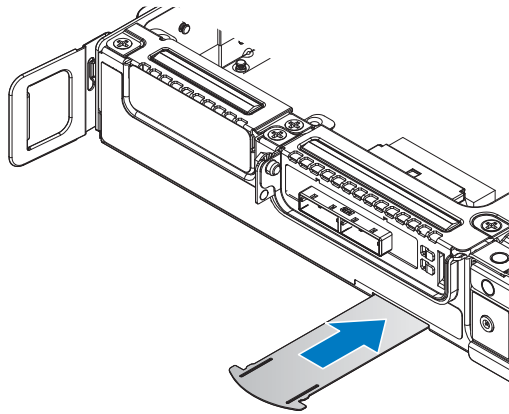

**Figure 3. Service Tag location**



## Documentation resources

This section provides information about the documentation resources for your system.

**Table 7. Additional documentation resources for your system**

<b>Task</b>	<b>Document</b>	<b>Location</b>
Setting up your system	For information about installing the system into a rack, see the Rack documentation included with your rack solution.	<a href="http://Dell.com/dssmanuals">Dell.com/dssmanuals</a>
	For information about turning on the system and the technical specifications of your system, see the Getting Started With Your System document that is shipped with your system.	<a href="http://Dell.com/dssmanuals">Dell.com/dssmanuals</a>
Configuring your system	For information about the iDRAC features, configuring and logging in to iDRAC, and managing your system remotely, see the Integrated Dell Remote Access Controller User's Guide.	<a href="http://Dell.com/idracmanuals">Dell.com/idracmanuals</a>
	For information about installing the operating system, see the operating system documentation.	<a href="http://Dell.com/operatingsystemmanuals">Dell.com/operatingsystemmanuals</a>
	For information about understanding Remote Access Controller Admin (RACADM) subcommands and supported RACADM interfaces, see the RACADM Command Line Reference Guide for iDRAC.	<a href="http://Dell.com/idracmanuals">Dell.com/idracmanuals</a>
	For information about updating drivers and firmware, see the Methods to download firmware and drivers section in this document.	<a href="http://Dell.com/support/drivers">Dell.com/support/drivers</a>
Managing your system	For information about systems management software offered by Dell, see the Dell OpenManage Systems Management Overview Guide.	<a href="http://Dell.com/openmanagemanuals">Dell.com/openmanagemanuals</a>
	For information about setting up, using, and troubleshooting OpenManage, see the Dell OpenManage Server Administrator User's Guide.	<a href="http://Dell.com/openmanagemanuals">Dell.com/openmanagemanuals</a>

**Table 7. Additional documentation resources for your system (continued)**

<b>Task</b>	<b>Document</b>	<b>Location</b>
	For information about installing, using, and troubleshooting Dell OpenManage Essentials, see the Dell OpenManage Essentials User's Guide.	<a href="http://Dell.com/openmanagemanuals">Dell.com/openmanagemanuals</a>
	For information about installing and using Dell SupportAssist, see the Dell EMC SupportAssist Enterprise User's Guide.	<a href="http://Dell.com/SupportAssist Enterprise">Dell.com/SupportAssist Enterprise</a>
	For information about installing and using Active System Manager (ASM), see the Active System Manager User's Guide.	<a href="http://Dell.com/asmdocs">Dell.com/asmdocs</a>
	For understanding the features of Dell Lifecycle Controller (LCC), see the Dell Lifecycle Controller User's Guide.	<a href="http://Dell.com/idracmanuals">Dell.com/idracmanuals</a>
	For information about partner programs enterprise systems management, see the OpenManage Connections Enterprise Systems Management documents.	<a href="http://Dell.com/omconnectionsenterprisesystemsmanagement">Dell.com/omconnectionsenterprisesystemsmanagement</a>
	For information about connections and client systems management, see the OpenManage Connections Client Systems Management documentation.	<a href="http://Dell.com/dellclientcommandsuitemanuals">Dell.com/dellclientcommandsuitemanuals</a>
	For information about viewing inventory, performing configuration and monitoring tasks, remotely turning on or off servers, and enabling alerts for events on servers and components using the Dell Chassis Management Controller (CMC), see the CMC User's Guide.	<a href="http://Dell.com/esmmanuals">Dell.com/esmmanuals</a>
Understanding event and error messages	For information about checking the event and error messages generated by the system firmware and agents that monitor system components, see the Dell Event and Error Messages Reference Guide.	<a href="http://Dell.com/openmanagemanuals">Dell.com/openmanagemanuals</a> > <a href="#">OpenManage software</a>

# Technical specifications

The technical and environmental specifications of your system are outlined in this section.

## Environmental specifications

 **NOTE:** For additional information about environmental measurements for specific system configurations, see [Dell.com/environmental\\_datasheets](https://Dell.com/environmental_datasheets).

### Temperature specifications

**Table 7. Temperature specifications**

Temperature	Specifications
Storage	-40°C to 65°C (-40°F to 149°F)
Continuous operation (altitudes under 950 m / 3,117 ft)	10°C to 35°C (50°F to 95°F), avoiding direct sunlight.
Fresh air	For information about fresh air, see Expanded Operating Temperature section.
Maximum temperature gradient (operation and storage)	20°C/h (36°F/h)

### Relative humidity specifications

**Table 8. Relative humidity specifications**

Temperature	Specifications
Storage	5% to 95% RH with 33°C (91°F) maximum dew point. Atmosphere must be non-condensing at all times.
Operating	10% to 80% relative humidity with 29°C (84.2°)

## Maximum vibration specifications

**Table 9. Maximum vibration specifications**

Maximum vibration	Specifications
Operating	0.26 Grms at 5 Hz to 350 Hz (all operation orientations).
Storage	1.88 Grms at 10 Hz to 500 Hz for 15 min (all six sides tested).

## Maximum shock specifications

**Table 10. Maximum shock specifications**

Maximum shock	Specifications
Operating	24 executed shock pulses 6 G in the positive and negative x, y, z axis of for up to 11 ms (four pulses on each side of the system).
Storage	Six consecutively executed shock pulses of 71 G in the positive and negative x, y, z axes for up to 2 ms (one pulse on each side of the system).

## Maximum altitude specifications

**Table 11. Maximum altitude specifications**

Temperature	Specifications
Operating	3,048 m (10,000 ft)
Storage	12,000 m (39,370 ft)

## Operating temperature de-rating specifications

**Table 12. Operating temperature de-rating specifications**

Operating temperature de-rating	Specifications
Up to 35°C (95°F)	Maximum temperature is reduced by 1°C/300 m (1°F/547 ft) above 950 m (3,117 ft).
35°C to 40°C (95°F to 104°F)	Maximum temperature is reduced by 1°C/175 m (1°F/319 ft) above 950 m (3,117 ft).
40°C to 45°C (104°F to 113°F)	Maximum temperature is reduced by 1°C/125 m (1°F/228 ft) above 950 m (3,117 ft).



### Related Links

[Expanded operating temperature]

## Particulate and gaseous contamination specifications

The following table defines the limitations that help avoid any equipment damage or failure from particulates and gaseous contamination. If the levels of particulates or gaseous pollution exceed the specified limitations and result in equipment damage or failure, you may need to rectify the environmental conditions. Re-mediation of environmental conditions is the responsibility of the customer.

**Table 13. Particulate contamination specifications**

Particulate contamination	Specifications
Air filtration	<p>Data center air filtration as defined by ISO Class 8 per ISO 14644-1 with a 95% upper confidence limit.</p> <p> <b>NOTE:</b> This condition applies to data center environments only. Air filtration requirements do not apply to IT equipment designed to be used outside a data center, in environments such as an office or factory floor.</p>
Conductive dust	<p> <b>NOTE:</b> Air entering the data center must have MERV11 or MERV13 filtration.</p> <p>Air must be free of conductive dust, zinc whiskers, or other conductive particles.</p> <p> <b>NOTE:</b> This condition applies to data center and non-data center environments.</p>

**Table 13. Particulate contamination specifications (continued)**

Particulate contamination	Specifications
Corrosive dust	<ul style="list-style-type: none"> <li>Air must be free of corrosive dust.</li> <li>Residual dust present in the air must have a deliquescent point less than 60% relative humidity.</li> </ul> <p> <b>NOTE:</b> This condition applies to data center and non-data center environments.</p>

**Table 14. Gaseous contamination specifications**

Gaseous contamination	Specifications
Copper coupon corrosion rate	<300 Å/month per Class G1 as defined by ANSI/ISA71.04-1985.
Silver coupon corrosion rate	<200 Å/month as defined by AHSRAE TC9.9.
<p> <b>NOTE:</b> Maximum corrosive contaminant levels measured at ≤50% relative humidity.</p>	

### Standard operating temperature specifications

**Table 15. Standard operating temperature specifications**

Standard operating temperature	Specifications
Continuous operation (altitudes under 950 m / 3,117 ft)	10°C to 35°C (50°F to 95°F), avoiding direct sunlight.

### Expanded operating temperature specifications

**Table 16. Expanded operating temperature specifications**

Expanded operating temperature	Specifications
≤10% of annual operating hours	<p>5°C to 40°C (41°F to 104°F), avoiding direct sunlight on the equipment.</p> <p> <b>NOTE:</b> Outside the standard operating temperature (10°C to 35°C / 50°F to 95°F), the system can operate for a maximum of 10% of its annual operating hours in temperatures as low as 5°C (41°F) and as high as 40°C (104°F).</p> <p>For temperatures between 35°C and 40°C (95°F and 104°F), de-rate maximum allowable temperature by 1°C per 175 m above 950 m (1°F per 319 ft).</p>

**Table 16. Expanded operating temperature specifications**

Expanded operating temperature	Specifications
≤1% of annual operating hours	<p data-bbox="672 282 1219 340">–5°C to 45°C (23°F to 113°F) at 5% to 90% RH with 29°C (84°F) dew point.</p> <p data-bbox="672 362 1219 482"> <b>NOTE:</b> Outside the standard operating temperature (10°C to 35°C / 50°F to 95°F), the system can operate down to –5°C (23°F) or up to 45°C (113°F) for a maximum of 1% of its annual operating hours.</p> <p data-bbox="672 496 1219 623">For temperatures between 40°C and 45°C (104°F and 113°F), de-rate maximum allowable temperature by 1°C per 125 m above 950 m (1°F per 228 ft).</p>

 **NOTE:** When operating in the expanded temperature range, system performance may be impacted.







 **NOTE:** When operating in the expanded temperature range, ambient temperature warnings may be reported in the System Event Log.

**Expanded operating temperature restrictions**

- Do not perform a cold startup below 5°C (41°F).
- The specified operating temperature is based on a maximum altitude of 950 m (3,116 ft).

# Installing and removing server components

## Safety instructions

-  **WARNING:** Whenever you need to lift the system, get others to assist you. To avoid injury, do not attempt to lift the system by yourself.
-  **WARNING:** Opening or removing the system cover while the system is powered on may expose you to a risk of electric shock.
-  **CAUTION:** Do not operate the system without the cover for a duration exceeding five minutes.
-  **CAUTION:** Many repairs may only be done by a certified service technician. You should only perform troubleshooting and simple repairs as authorized in your product documentation, or as directed by the online or telephone service and support team. Damage due to servicing that is not authorized by Dell is not covered by your warranty. Read and follow the safety instructions that are shipped with your product.
-  **CAUTION:** Operating the system without the system cover can result in component damage.
-  **NOTE:** Dell recommends that you always use a static mat and static strap while working on components inside the system.
-  **NOTE:** To ensure proper operation and cooling, all bays in the system and system fans must be populated always with a component or with a blank.

## Before working inside your system

### Prerequisites

Follow the safety guidelines listed in Safety instructions.

### Step

- 1 Turn off the server, including any attached peripherals.
- 2 Disconnect the system from the electrical outlet and disconnect the peripherals.
- 3 If applicable, remove the system from the rack.

For more information, see the Rack Installation placemat at [Dell.com/dssmanuals](http://Dell.com/dssmanuals).



## After working inside your system

### Prerequisites

Follow the safety guidelines listed in Safety instructions.

### Step

- 1 If applicable, install the system into the rack.  
For more information, see the Rack Installation placemat at [Dell.com/dssmanuals](http://Dell.com/dssmanuals).
- 2 Reconnect the peripherals and connect the system to the electrical outlet.
- 3 Turn on the system, including any attached peripherals.

## Recommended tools

You need the following tools to perform the removal and installation procedures:

- Key to the bezel lock  
The key is needed only if your system includes a bezel.
- Phillips #1 screwdriver
- Phillips #2 screwdriver
- 1/4 inch flat head screwdriver
- Torx #T20 screwdriver
- Torx #T30 screwdriver
- Torx #T6, #T8, #T10, and #T15 screwdrivers
- Wrist grounding strap

You need the following tools to assemble the cables for a DC power supply unit.

- AMP 90871-1 hand-crimping tool or equivalent
- Tyco Electronics 58433-3 or equivalent
- Wire-stripper pliers to remove insulation from size 10 AWG solid or stranded, insulated copper wire





**NOTE:** Use alpha wire part number 3080 or equivalent (65/30 stranding).

## Hard drive

For more information on hard drives, see the 512e and 4Kn Disk Formats whitepaper and 4K Sector HDD FAQ document at [Dell.com/dssmanuals](http://Dell.com/dssmanuals).

All hard drives are connected to the server board through the hard drive backplane. Hard drives are supplied in hot swappable hard drive carriers that fit in the hard drive slots.

 **CAUTION: Before attempting to remove or install a hard drive while the system is running, see the documentation for the storage controller card to ensure that the host adapter is configured correctly to support hot swappable hard drive removal and insertion.**

 **CAUTION: Do not turn off or restart your system while the hard drive is being formatted. Doing so can cause a hard drive failure.**

Use only hard drives that have been tested and approved for use with the hard drive backplane.

When you format a hard drive, allow enough time for the formatting to be complete. Be aware that high-capacity hard drives can take a long time to format.

## Removing 3.5-inch hard drive from a tray

### Prerequisites

- 1 Follow the safety guidelines listed in the Safety instructions section.
- 2 Complete the procedure listed in Before working inside your system.

**⚠ CAUTION:** To maintain proper system cooling, all empty hard drive slots must have hard drive blanks installed.

### Steps

- 1 Grasp the tray handle with one hand, and use your thumb to push the plunger up to release the HDD tray.
- 2 Continue to hold the plunger and use the tray handle to pull the tray out from the chassis.

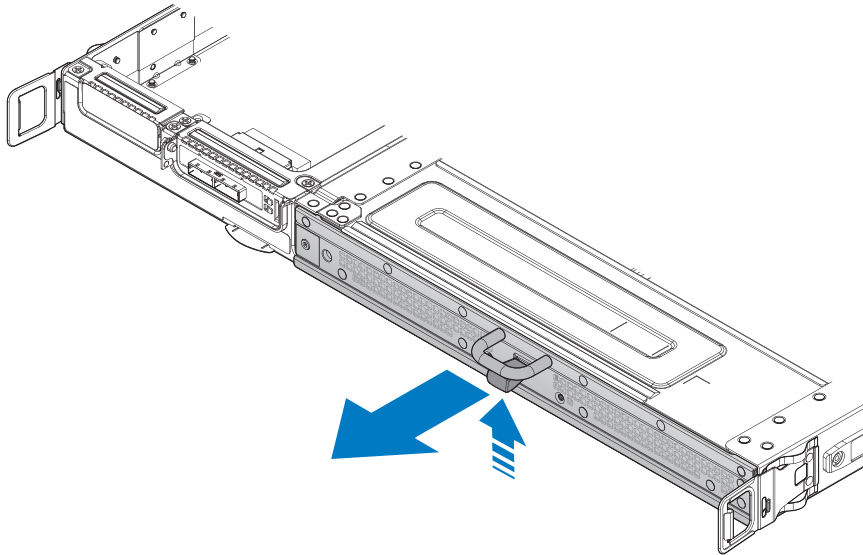

**Figure 4.** Releasing the HDD tray

- 3 Remove the HDD tray from the server.

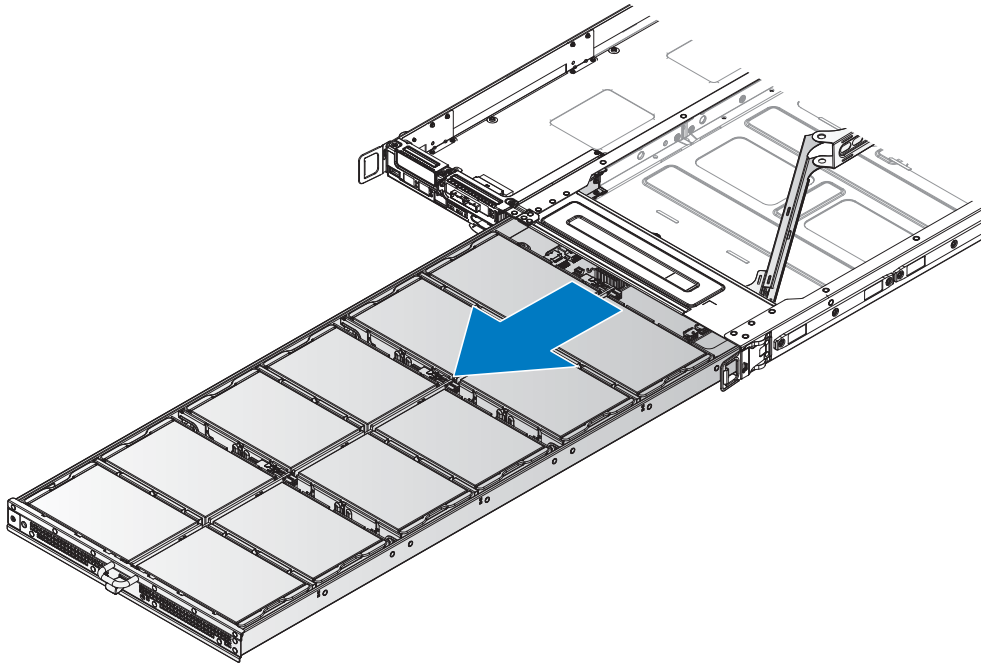

**Figure 5. Removing the HDD tray**

- 4 Grasp the locking lever on the HDD carrier.
- 5 Rotate the locking lever to a 90° angle. The HDD disengages from the backplane.

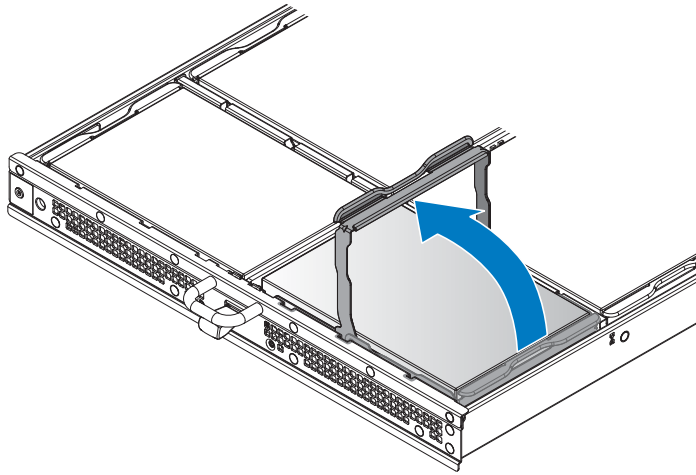

**Figure 6. Unlocking the 3.5-inch HDD assembly**

- 6 Lift the HDD assembly up to remove from the chassis.

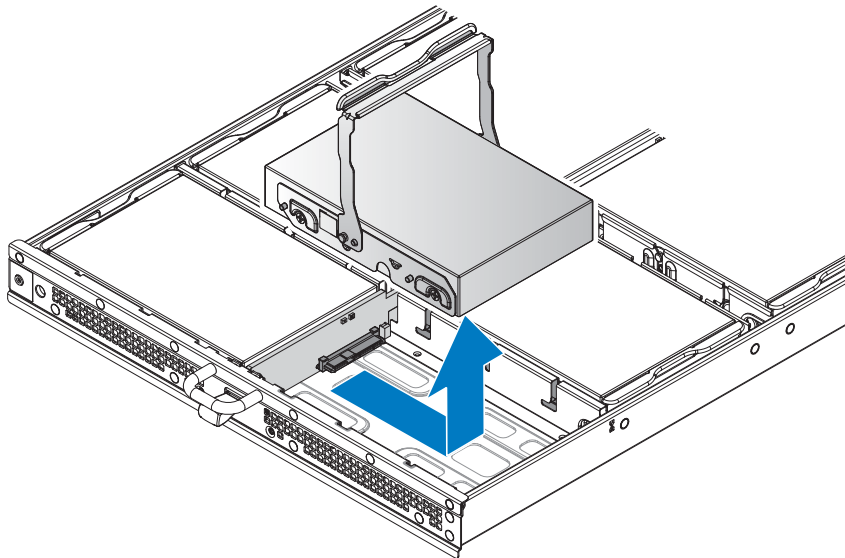

**Figure 7. Removing the 3.5-inch HDD assembly**

- 7 Remove the screws securing the HDD to the HDD carrier.
- 8 Lift up the HDD to separate it from the HDD carrier.

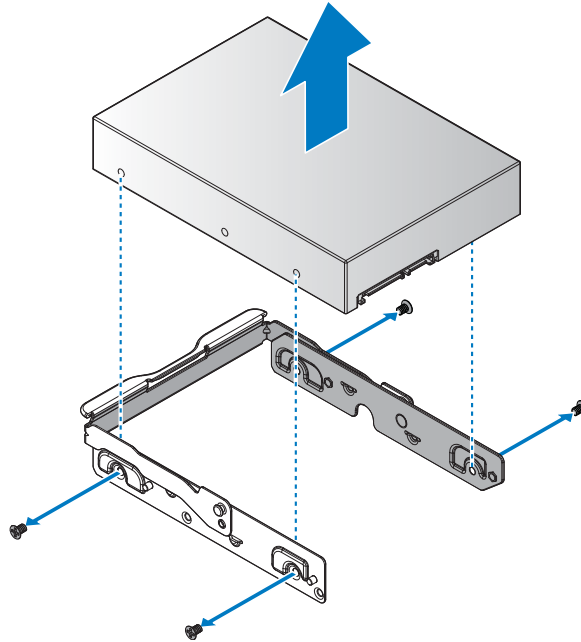

**Figure 8. Removing the 3.5-inch HDD**

#### Next steps

- 1 Install the 3.5-inch HDD into a tray.
- 2 Complete the procedure listed in After working inside your system.

#### Related Links

- [Installing 3.5-inch hard drive into a tray](#)

## Installing 3.5-inch hard drive into a tray

### Prerequisites

- 1 Follow the safety guidelines listed in the Safety instructions section.
- 2 Complete the procedure listed in Before working inside your system.

### Steps

- 1 Align the HDD in the HDD carrier. Make sure the screw holes on the HDD are aligned with the screw holes on the HDD carrier.
- 2 Place the HDD in the HDD carrier and secure with the provided screws.

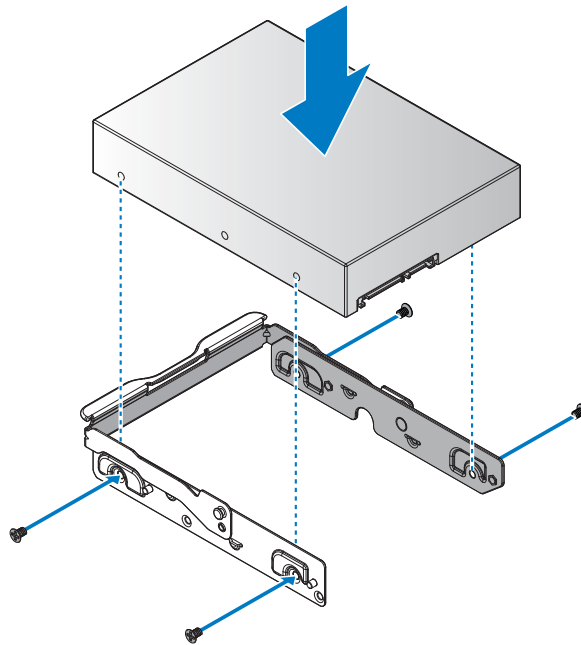
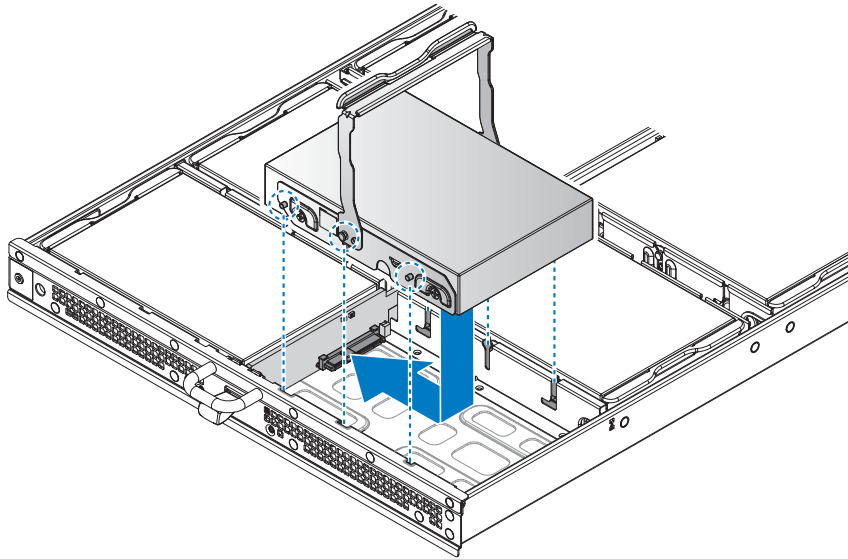

**Figure 9. Installing the 3.5-inch HDD**

**Table 17. Assembly material**

Description	Quantity	Torque (lbs/inch)
#6-32 screw	4 (1 per HDD)	6 ± 0.2

- 3 Grasp the locking lever on the HDD carrier and pull up to a 90° angle.
- 4 Lower the HDD assembly in place and align the studs with the slots on the partition walls.



**Figure 10. Installing the 3.5-inch HDD assembly**

- 5 Lower the locking lever until it touches the stop point on the HDD carrier.

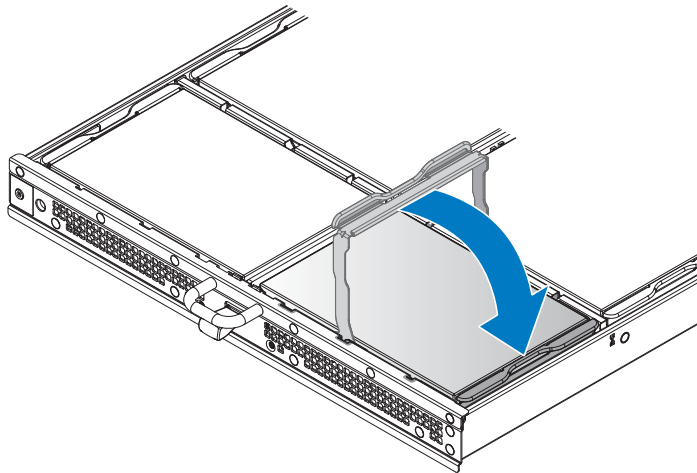

**Figure 11. Installing the 3.5-inch HDD assembly**



- 6 Install the HDDs on the HDD tray.
- 7 Push the HDD tray in until it is fully seated in the chassis.  
The HDD tray locks in place after it is properly seated.

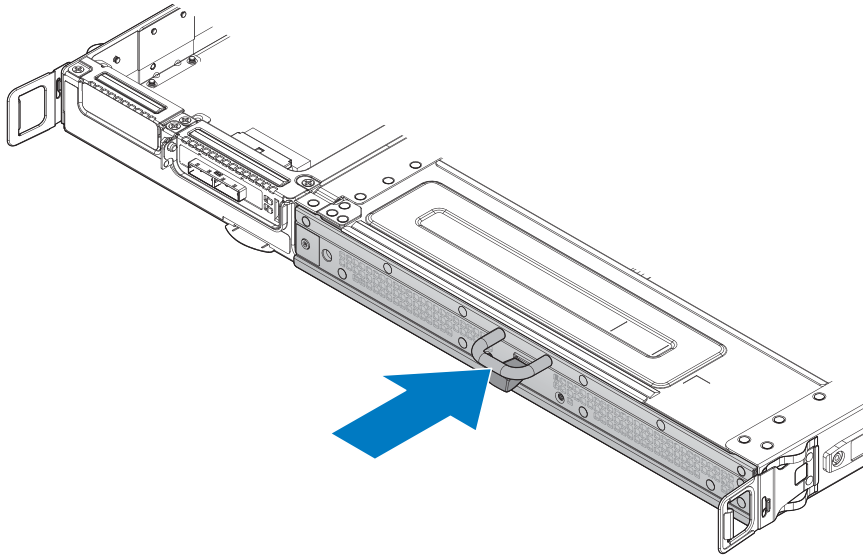

**Figure 12. Installing the HDD tray**

#### Next steps

- 1 Complete the procedure listed in After working inside your system.

### Removing 2.5-inch hard drive from a tray

#### Prerequisites

- 1 Follow the safety guidelines listed in the Safety instructions section.
- 2 Complete the procedure listed in Before working inside your system.

**⚠ CAUTION: To maintain proper system cooling, all empty hard drive slots must have hard drive blanks installed.**

## Steps

- 1 Grasp the tray handle with one hand, and use your thumb to push the plunger up to release the HDD tray.
- 2 Continue to hold the plunger and use the tray handle to pull the tray out from the chassis.
- 3 Remove the HDD tray from the server.
- 4 Grasp the locking lever on the HDD carrier.
- 5 Rotate the locking lever to a 90° angle. The HDD disengages from the backplane.

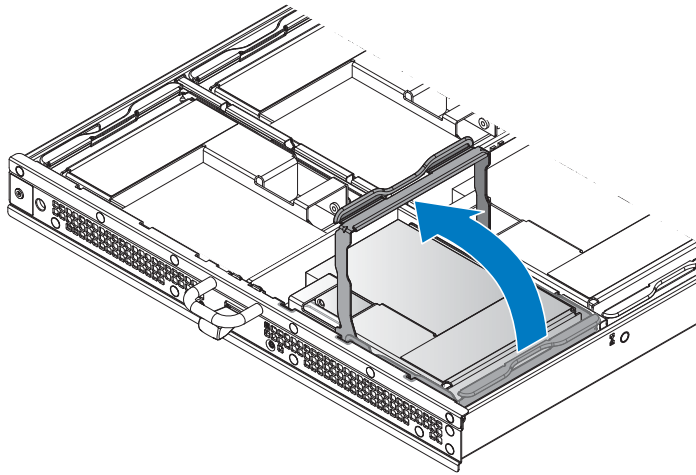

**Figure 13. Unlocking the 2.5-inch HDD assembly**

- Lift the HDD assembly up to remove from the chassis.

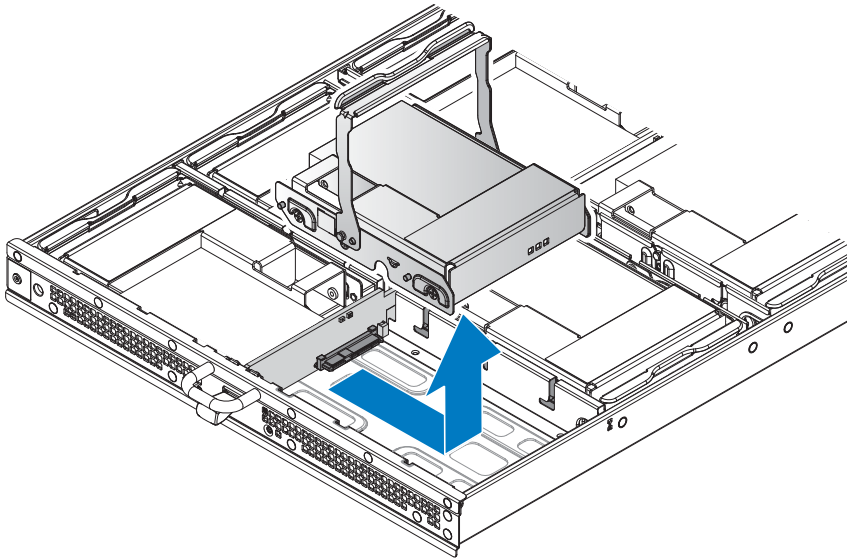

**Figure 14. Removing the 2.5-inch HDD assembly**

- 7 Remove the screws securing the HDD assembly to the HDD carrier.
- 8 Lift up the HDD assembly to separate it from the HDD carrier.

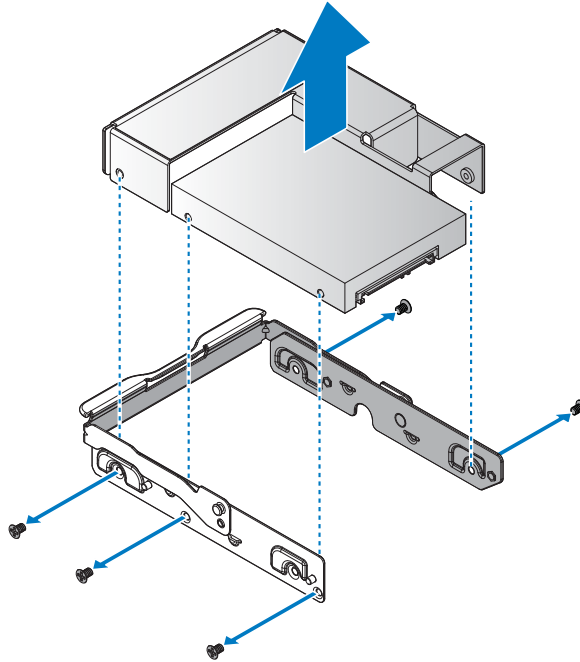

**Figure 15. Removing the 2.5-inch HDD assembly from the HDD carrier**

- 9 Remove the screws securing the HDD to the adapter bracket.
- 10 Remove the HDD from the adapter bracket.

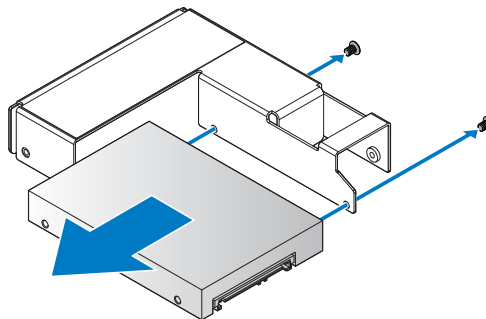

**Figure 16. Removing the 2.5-inch HDD**

### Next steps

- 1 Install the 2.5-inch HDD into a tray.
- 2 Complete the procedure listed in After working inside your system.

### Related Links

- Installing 2.5-inch hard drive into a tray

## Installing 2.5-inch hard drive into a tray

### Prerequisites

- 1 Follow the safety guidelines listed in the Safety instructions section.
- 2 Complete the procedure listed in Before working inside your system.

### Steps

- 1 Align the HDD in the adapter bracket. Make sure the screw holes on the HDD are aligned with the screw holes on the adapter bracket.
- 2 Secure the HDD and adapter bracket with the provided screws.

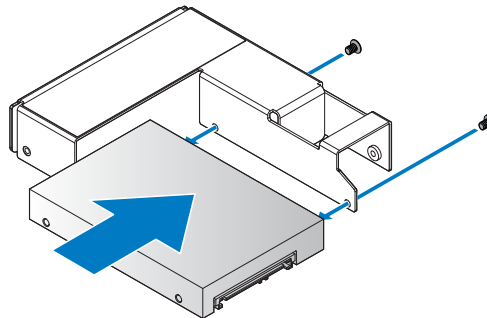
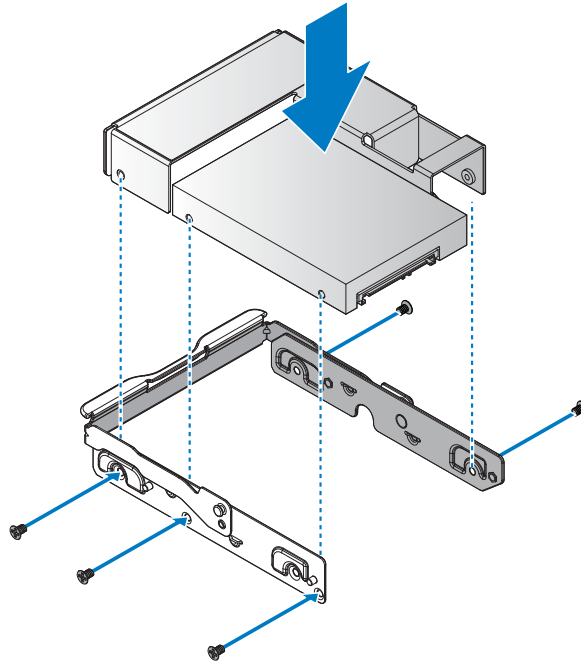

**Figure 17. Installing the 2.5-inch HDD**

**Table 18. Assembly material**

Description	Quantity	Torque (lbs/inch)
M3 screw	2 (1 per HDD)	$6 \pm 0.2$

- 3 Align the HDD assembly in the HDD carrier. Make sure the screw holes on the HDD assembly are aligned with the screw holes on the HDD carrier.
- 4 Place the HDD assembly in the HDD carrier and secure with the provided screws.

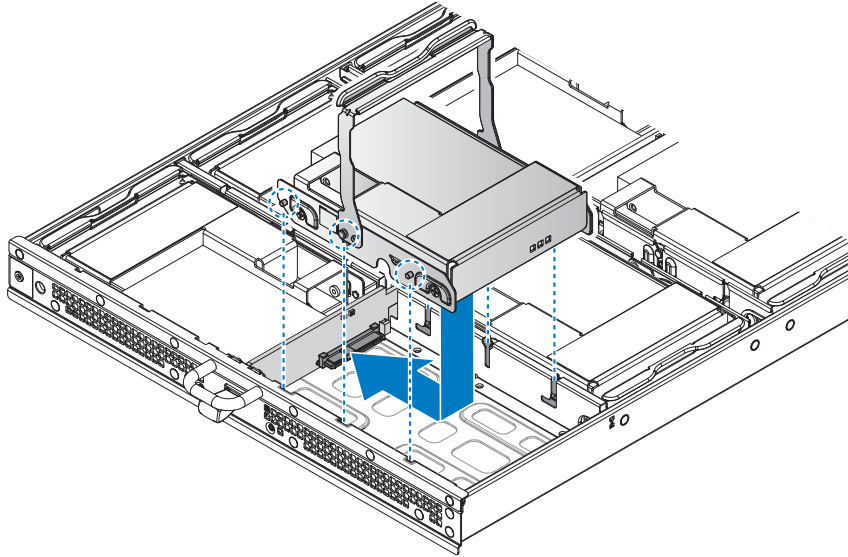

**Figure 18. Installing the 2.5-inch HDD assembly to the HDD carrier**

**Table 19. Assembly material**

Description	Quantity	Torque (lbs/inch)
M3 screw	5 (1 per HDD)	6 ± 0.2

- 5 Grasp the locking lever on the HDD carrier and pull up to a 90° angle.
- 6 Lower the HDD assembly in place and align the studs with the slots on the partition walls.



**Figure 19. Installing the 2.5-inch HDD assembly**

- 7 Lower the locking lever until it touches the stop point on the HDD carrier.

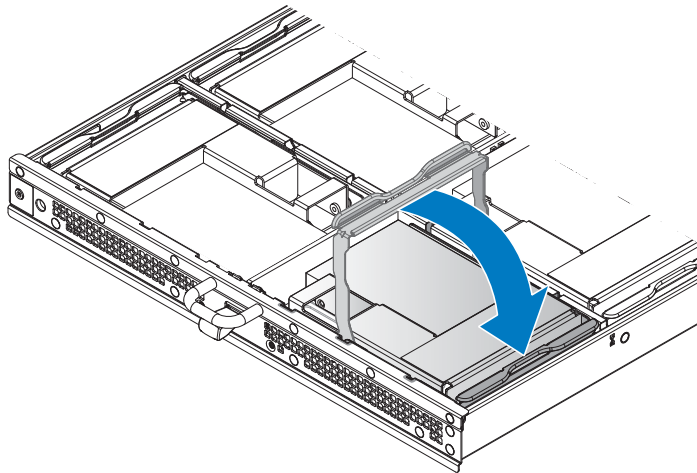

**Figure 20. Installing the 2.5-inch HDD assembly**

- 8 Install the HDDs on the HDD tray.
- 9 Push the HDD tray in until it is fully seated in the chassis.  
The HDD tray locks in place after it is properly seated.

## NPDB board

### Removing NPDB

#### Prerequisites

- 1 Ensure that you read the Safety instructions.
- 2 Complete the procedure listed in Before working inside your system.

#### Steps

- 1 Disconnect all cables from the NPDB.
- 2 Remove the securing screw from the NPDB.
- 3 Lift the NPDB to remove from the chassis.

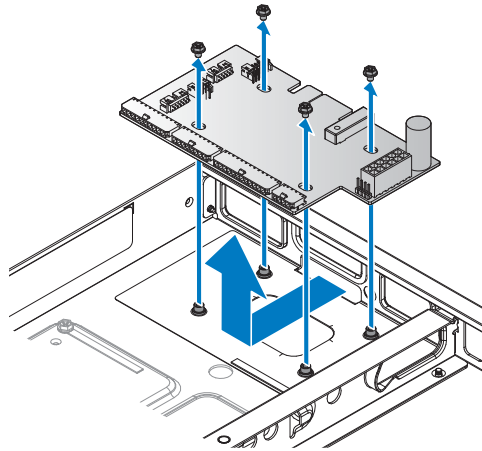

**Figure 21. Removing the NPDB**

#### Next steps

- 1 Install the NPDB.
- 2 Complete the procedure listed in After working inside your system.

#### Related Links

- [Installing NPDB](#)



## Installing NPDB

### Prerequisites

Ensure that you read the Safety instructions.

### Steps

- 1 Align the screw holes on the NPDB to the screw posts on the chassis.
- 2 Lower the NPDB in place.
- 3 Secure the NPDB with the screws.

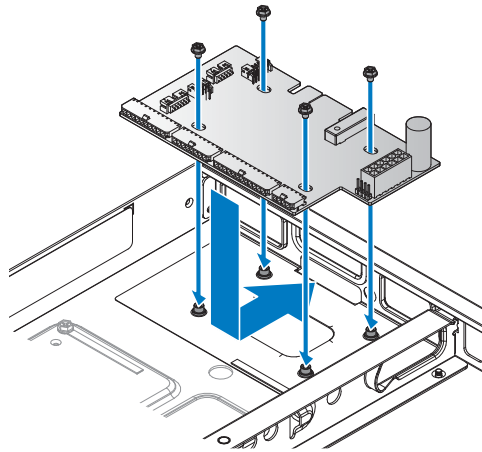
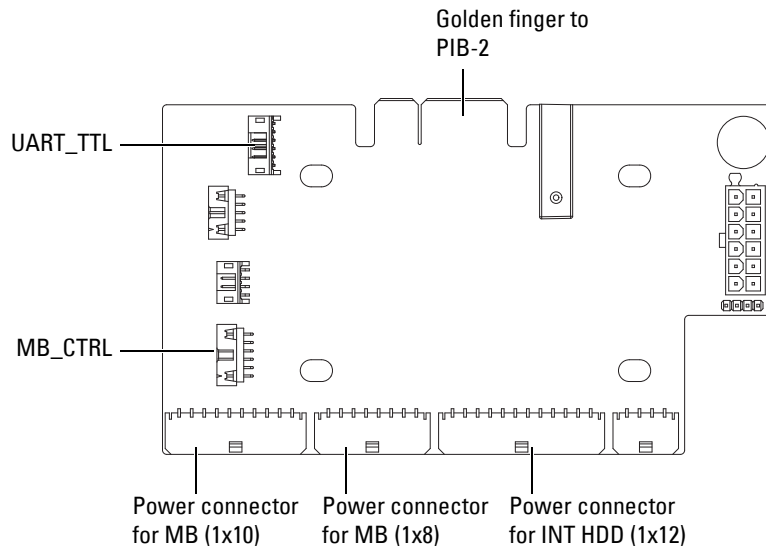

**Figure 22.** Installing the NPDB

**Table 20.** Assembly material

Description	Quantity	Torque (lbs/inch)
#6-32 screw	4	$6 \pm 0.2$

- 4 Connect all cables from the server to the NPDB.



**Figure 23. NPDB overview**

Next steps

- 1 Complete the procedure listed in After working inside your system.

# Hard drive backplane

## Removing HDD backplane

### Prerequisites

- 1 Ensure that you read the Safety instructions.
- 2 Complete the procedure listed in Before working inside your system.
- 3 Remove the 3.5-inch or 2.5-inch hot swappable HDDs.

### Steps

- 1 Pull up the latches on each side to release and remove the plastic clip at the top of HDD backplane.

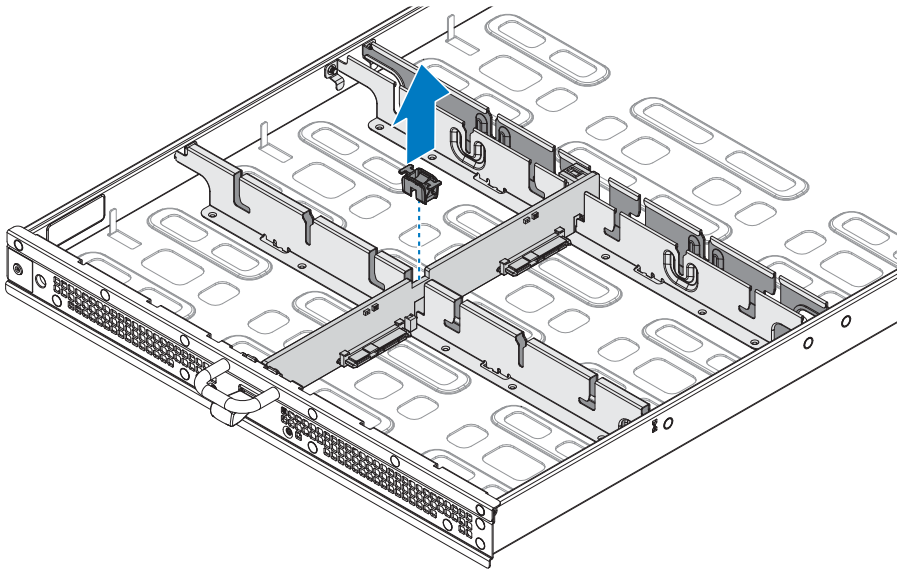

**Figure 24.** Removing the plastic clip

- 2 Disconnect the power or signal cable connectors from both sides of the HDD backplane.
- 3 Lift up the HDD backplane to remove from the chassis.

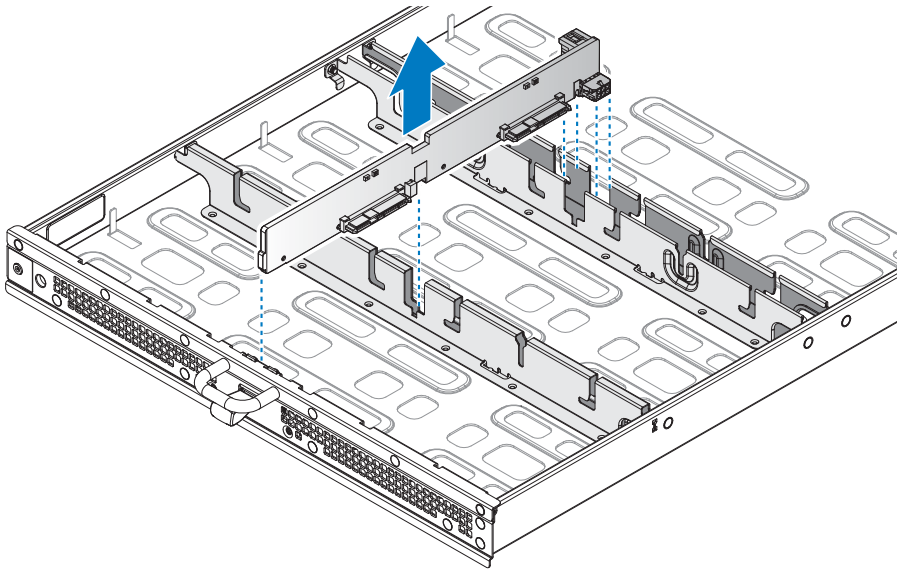

**Figure 25. Removing the HDD backplane**

#### Next steps

- 1 Install the HDD backplane.
- 2 Complete the procedure listed in After working inside your system.

#### Related Links

- [Removing 3.5-inch hard drive from a tray](#)
- [Removing 2.5-inch hard drive from a tray](#)
- [Installing HDD backplane](#)

## Installing HDD backplane

### Prerequisites

- 1 Ensure that you read the Safety instructions.
- 2 Complete the procedure listed in Before working inside your system.

### Steps

- 1 Align the HDD backplane over the chassis making sure the HDD connection slots on the backplane are positioned on the bottom.
- 2 Slide the HDD backplane in place and press down to seat the backplane properly.

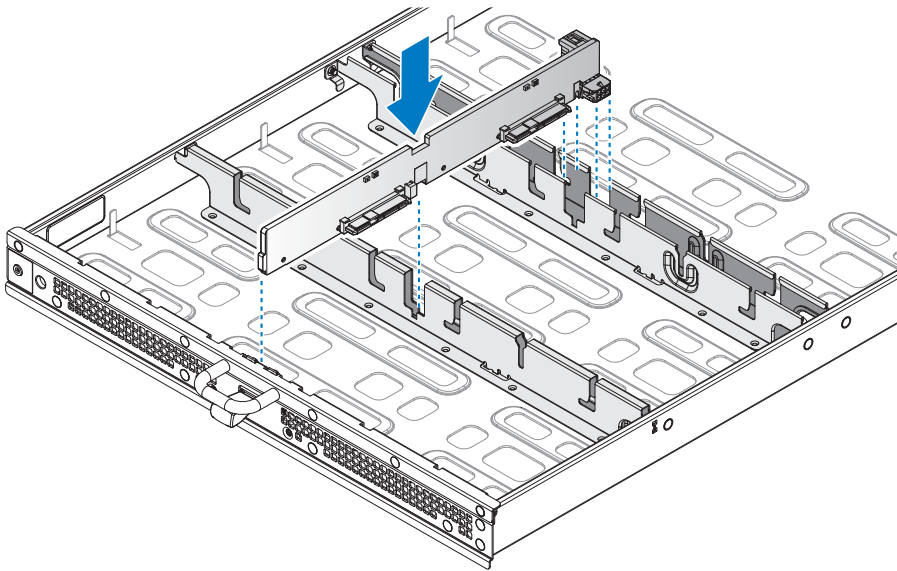

**Figure 26.** Installing the HDD backplane

- 3 Install the plastic clip over the HDD backplane and chassis brace.
- 4 Press down on the locking latches to secure the HDD backplane on the chassis.

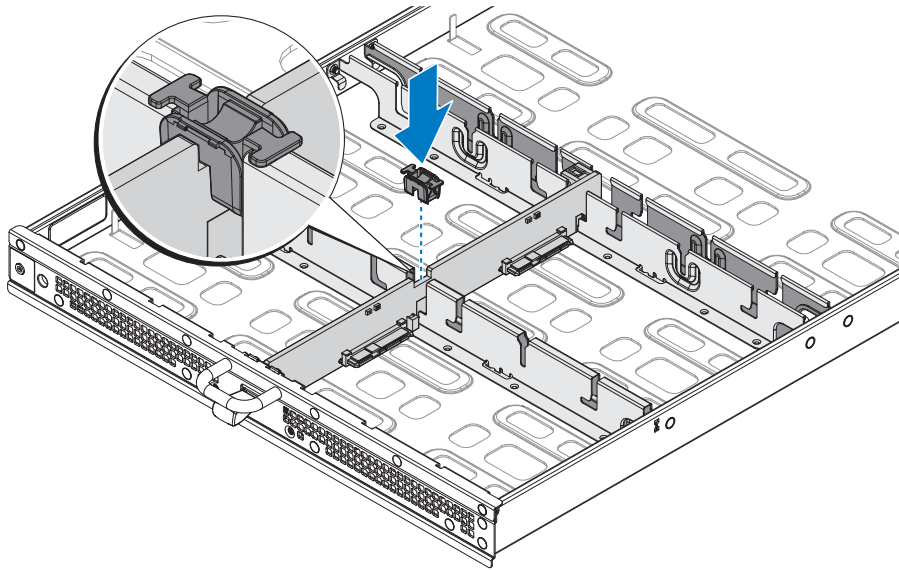

**Figure 27. Installing the plastic clip**

#### Next steps

- 1 Install the 3.5-inch or 2.5-inch hot swappable HDD.
- 2 Complete the procedure listed in [After working inside your system](#).

#### Related Links

- [Installing 3.5-inch hard drive into a tray](#)
- [Installing 2.5-inch hard drive into a tray](#)

# SAS expander board

## Removing SAS expander board

### Prerequisites

- 1 Ensure that you read the Safety instructions.
- 2 Complete the procedure listed in Before working inside your system.

### Steps

- 1 Remove the screw securing the SAS expander board.
- 2 Slide the SAS expander board as shown in the figure.
- 3 Remove the SAS expander board.

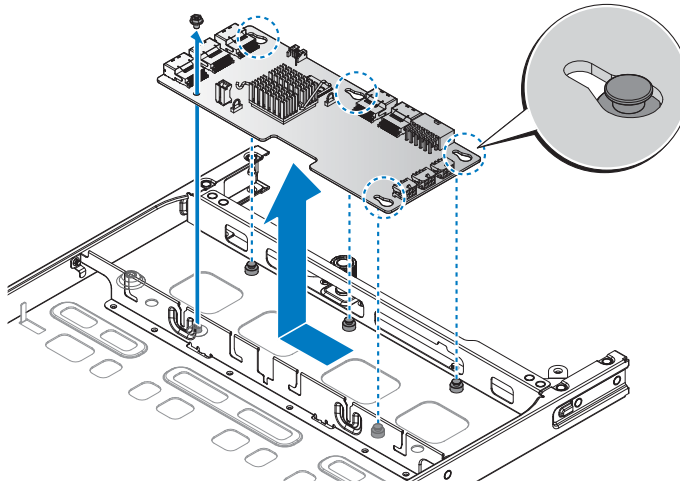

**Figure 28. Removing the SAS expander board**

### Next steps

- 1 Install the SAS expander board.
- 2 Complete the procedure listed in After working inside your system.

### Related Links

- [Installing SAS expander board](#)

## Installing SAS expander board

### Prerequisites

- 1 Ensure that you read the Safety instructions.
- 2 Complete the procedure listed in Before working inside your system.

### Steps

- 1 Align the locking wells on the SAS expander board to the locking posts on the chassis.
- 2 Install the SAS expander board and slide as shown in the following illustration.
- 3 Secure with the provided screw.

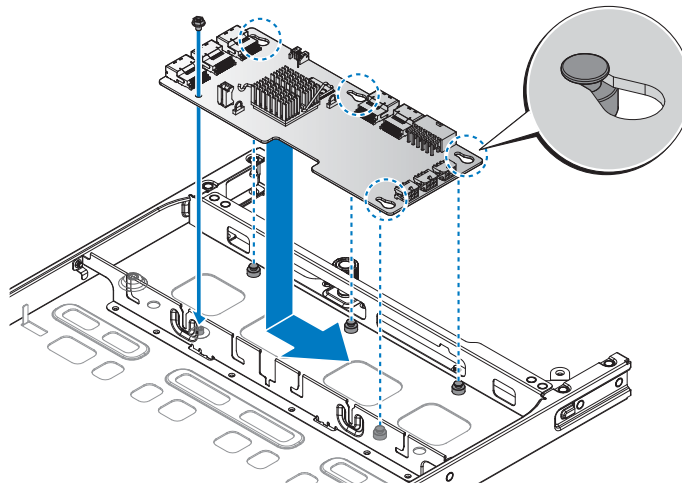

**Figure 29. Installing the SAS expander board**

**Table 21. Assembly material**

Description	Quantity	Torque (lbs/inch)
#6-32 screw	1	6 ± 0.2

### Next steps

- 1 Complete the procedure listed in After working inside your system.



# Cable management arm component

## Removing CMA in a hard drive tray

### Prerequisites

- 1 Ensure that you read the Safety instructions.
- 2 Complete the procedure listed in Before working inside your system.
- 3 Remove the 3.5-inch or 2.5-inch hot swappable HDDs.

### Steps

- 1 Locate the power cable connecting the CMA to the NPDB. Disconnect it from the NPDB.
- 2 Locate the signal cables connected to the PCIe raid or Mini PERC slot, see your specific configuration for the connection type. Disconnect the signal cable from the slot.

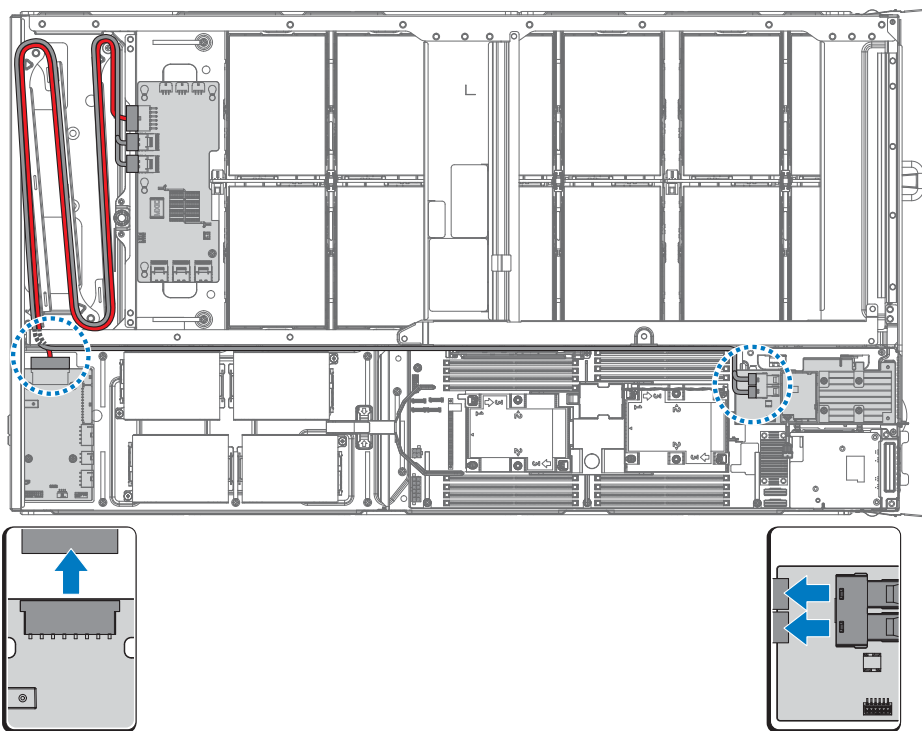

**Figure 30. Disconnect power cables**

- 3 Locate the screw securing the CMA to the rear of the chassis and remove it.
- 4 Gently move back the CMA and pull out the cables from the server board side of the chassis. The cables should now be on the tray side of the chassis.
- 5 Remove the CMA screw connected to the rear of the hard drive tray.
- 6 Disconnect the cables from the SAS expander board and pull them out of the hard drive tray.
- 7 Remove the CMA from the chassis. Make sure the cable ends do not catch on any components during removal to avoid damaging the server or the cables.

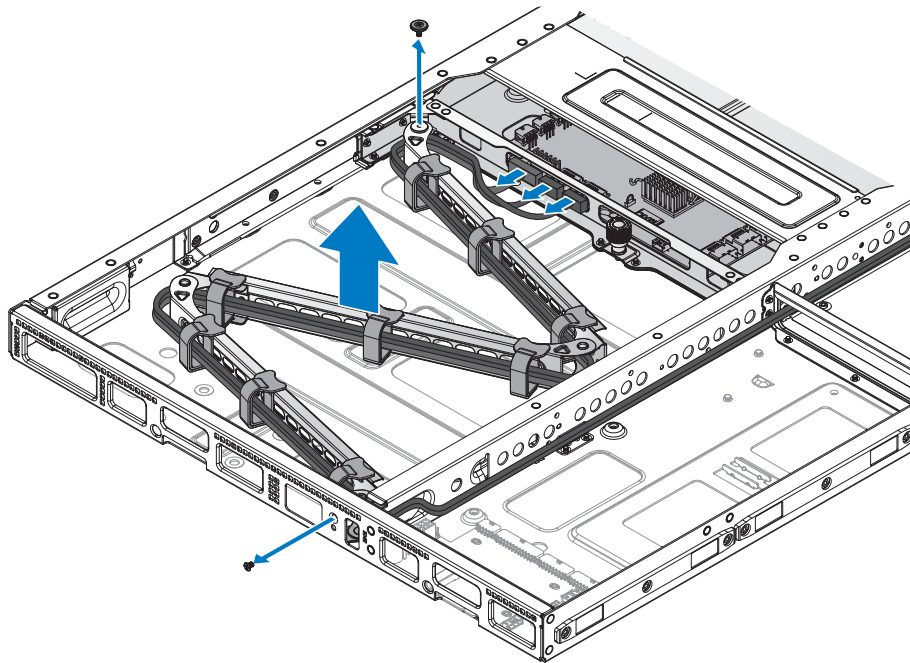

**Figure 31. Removing the CMA in the hard drive tray**

#### Next steps

- 1 Install the CMA.
- 2 Complete the procedure listed in [After working inside your system](#).

#### Related Links

- [Removing 3.5-inch hard drive from a tray](#)
- [Removing 2.5-inch hard drive from a tray](#)
- [Installing CMA in a hard drive tray](#)

## Installing CMA in a hard drive tray

### Prerequisites

- 1 Ensure that you read the Safety instructions.
- 2 Complete the procedure listed in Before working inside your system.

### Steps

- 1 Orient the CMA assembly as shown in Figure 32.

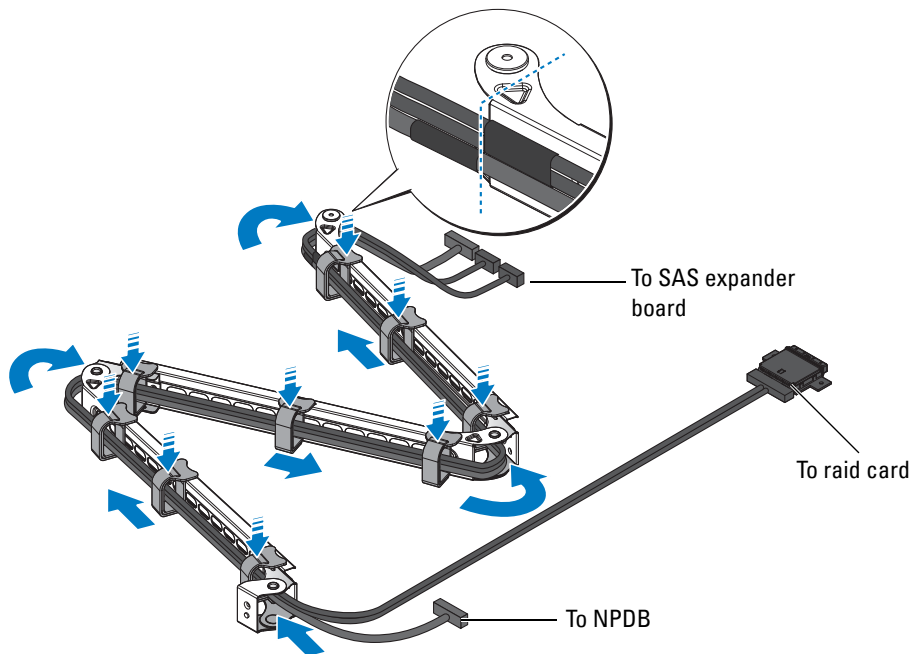

**Figure 32. Completed CMA assembly**

 **NOTE:** Make sure the soft side (loops) is facing the cables to prevent damage to the cables.

- 2 Insert the SAS expander end through the rear of the hard drive tray and align with the connectors on the SAS expander board.
- 3 Attach the end of the CMA arm over the flange on the supporting wall and insert the CMA screw.
- 4 Grasp the cables on the remaining side and run them through the middle wall of the chassis.
- 5 Align the CMA arm with the screw hole on the rear of the chassis.

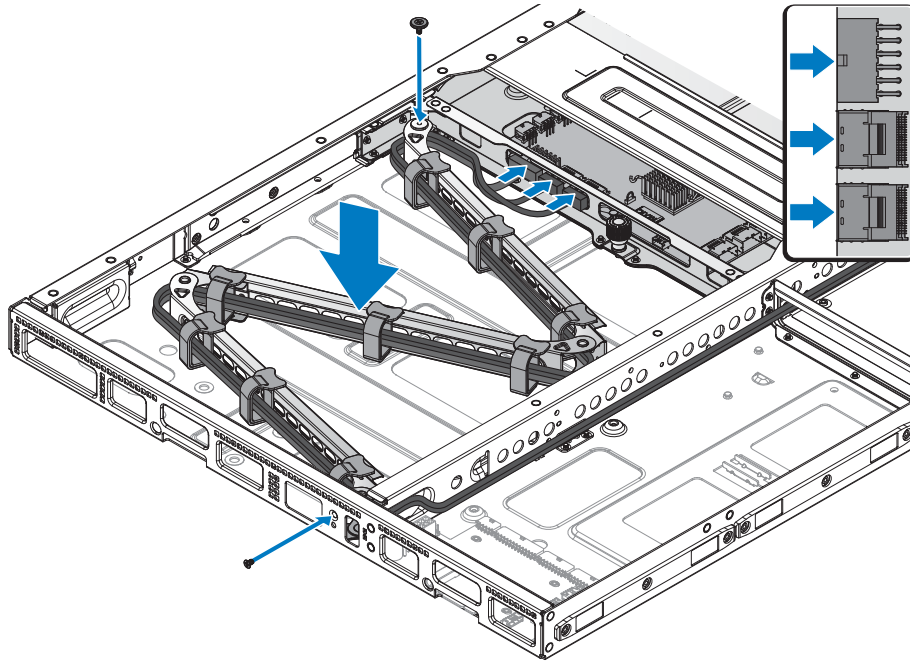

**Figure 33. Installing the CMA in a hard drive tray**

**Table 22. Assembly material**

Description	Quantity	Torque (lbs/inch)
#6-32 screw	1	6 ± 0.2

- 6 Connect the signal cable to either the PCIe raid or Mini PERC slots. This step is dependent on the specific configuration.
- 7 Connect the power cable to the NPDB.

### Next steps

- 1 Install the 3.5-inch or 2.5-inch hot swappable HDD.
- 2 Complete the procedure listed in After working inside your system.

### Related Links

- [Installing 3.5-inch hard drive into a tray](#)
- [Installing 2.5-inch hard drive into a tray](#)

# Getting help

## Contacting Dell

Dell provides several online and telephone based support and service options. If you do not have an active internet connection, you can find contact information about your purchase invoice, packing slip, bill, or Dell product catalog. Availability varies by country and product, and some services may not be available in your area. To contact Dell for sales, technical assistance, or customer service issues:

- 1 Go to [Dell.com/support](http://Dell.com/support).
- 2 Select your country from the drop-down menu on the lower right corner of the page.
- 3 For customized support:
  - a Enter your system Service Tag in the **Enter your Service Tag** field.
  - b Click **Submit**.  
The support page that lists the various support categories is displayed.
- 4 For general support:
  - a Select your product category.
  - b Select your product segment.
  - c Select your product.  
The support page that lists the various support categories is displayed.
- 5 For contact details of Dell Global Technical Support:
  - a Click **Global Technical Support**.
  - b The **Contact Technical Support** page is displayed with details to call, chat, or e-mail the Dell Global Technical Support team.

## Documentation feedback

You can rate the documentation or write your feedback on any of our Dell documentation pages and click **Send Feedback** to send your feedback.