

Dell Mobile Adapter Speakerphone MH3021P

User's Guide

Regulatory Model: MH3021Pu



Notes, cautions, and warnings



NOTE: A NOTE indicates important information that helps you make better use of your computer.



CAUTION: A CAUTION indicates either potential damage to hardware or loss of data and tells you how to avoid the problem



WARNING: A WARNING indicates a potential for property damage, personal injury, or death.

© 2020 Dell Inc. or its subsidiaries. All rights reserved. Dell, EMC, and other trademarks are trademarks of Dell Inc. or its subsidiaries. Other trademarks may be trademarks of their respective owners.

2020 -06

Rev. A00

Contents

What's in the box	4
Features	5
Front view	5
Back view	5
Using your Mobile Adapter Speakerphone	6
Troubleshooting	14
Specifications	18
Statutory information	19
Warranty	19

What's in the box

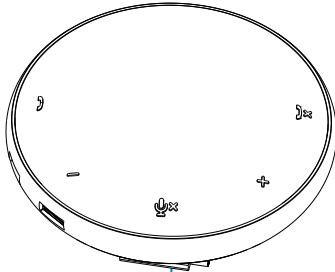

1

1 Mobile adapter speakerphone

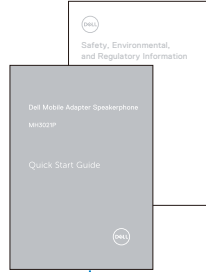

2

2 Documents

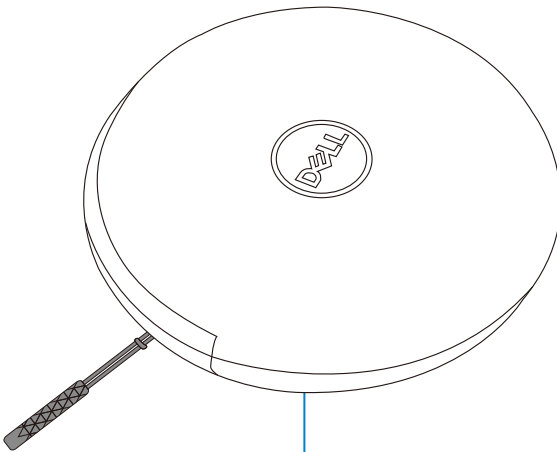

3

3 Pouch



Warranty for pouch is not covered.

Features

Front view

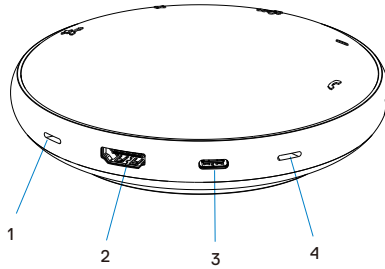

- | | | | |
|---|------------|---|------------|
| 1 | Microphone | 2 | HDMI port |
| 3 | USB-C port | 4 | Microphone |

Back view

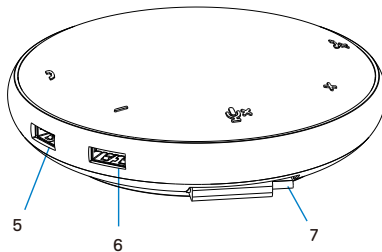

- | | | | |
|---|-------------|---|------------|
| 5 | USB-A port | 6 | USB-A port |
| 7 | USB-C cable | | |

Using your Mobile Adapter Speakerphone

1. Locate the USB-C cable at the bottom of your MH3021P.
Release the USB-C cable manually.

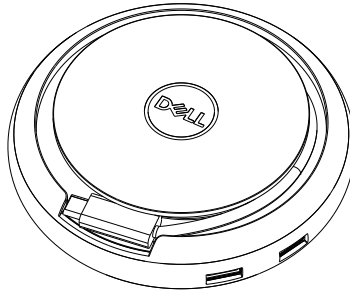

2. Connect the USB-C cable of your MH3021P to the Thunderbolt or USB-C (DisplayPort Alt Mode) port on your computer. Below image shows HDMI monitor and other devices connected to MH3021P without external power source to MH3021P.

Without Power Delivery

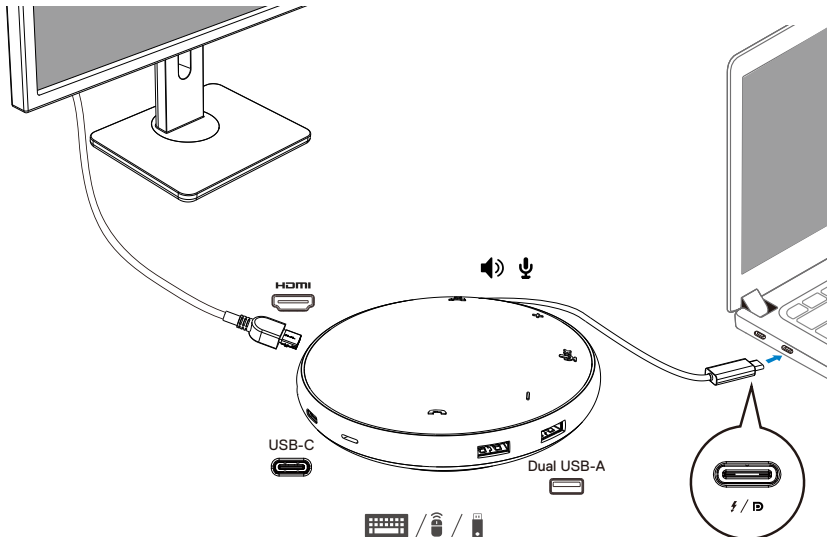

3. MH3021P supports power delivery up to 90W when connected to the Thunderbolt or USB-C (Display Port Alt Mode) port of your PC. Power source can be supplied by the adapter or USB-C monitor that support charging feature. Below two images show MH3021P connected to an external power source via USB-C power adapter or USB-C monitor.

With Power Delivery Via USB-C Power Adapter

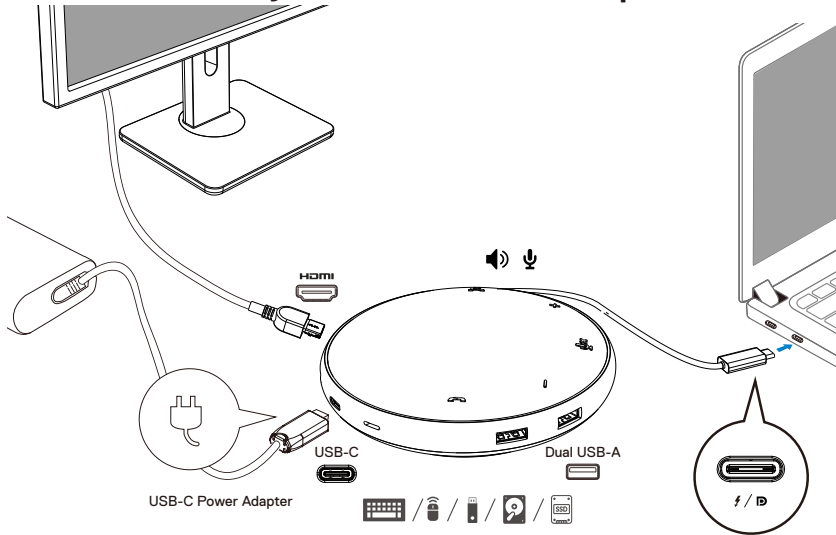

With Power Delivery Via USB-C Monitor

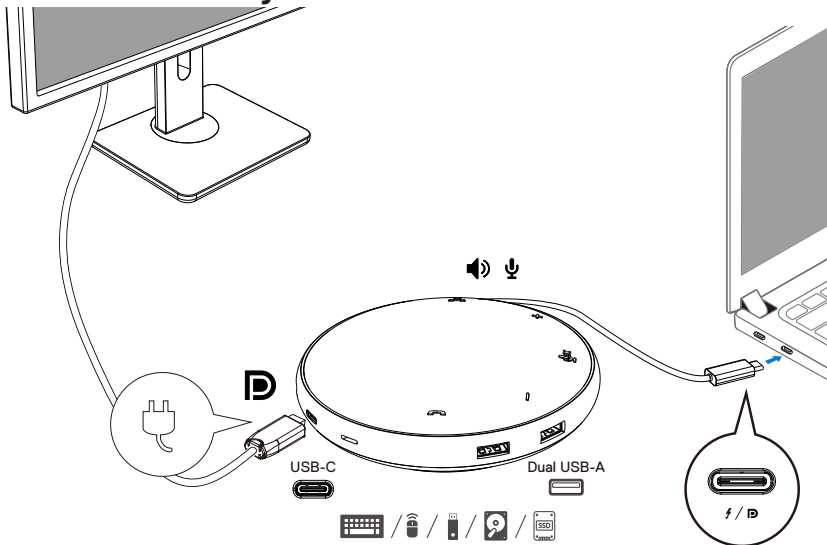

 **NOTE: MH3021P supports only one display at a time.**

4. MH3021P has the Speakerphone and Microphone, you can use it for communication after connecting your mobile adapter with the notebook.

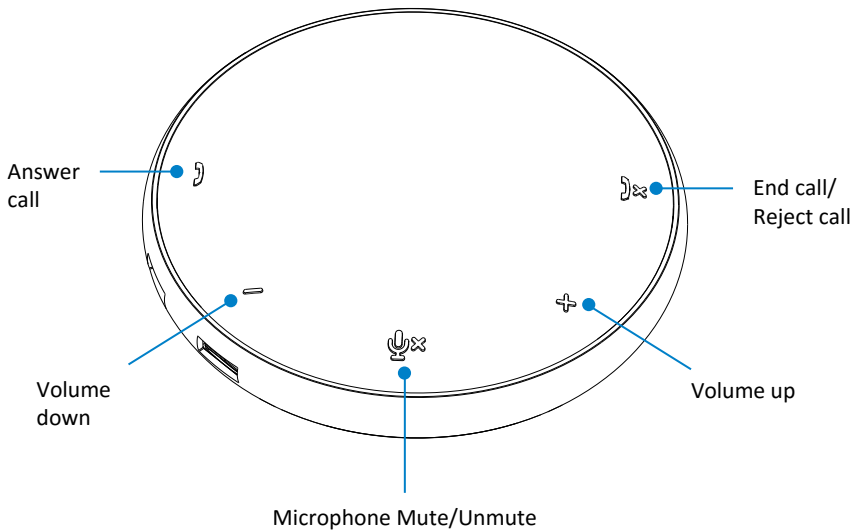

)	Answer call	Tap the Answer call button
)x	End call/Reject call	Tap the End/reject call button
+	Speaker volume up	Tap the volume up button
-	Speaker volume down	Tap the volume down button
μx	Mute/Unmute microphone	Tap the Mute microphone button



NOTE: MH3021P buttons work well with Skype for Business and Zoom.

5. Operation behavior in Skype for Business / Zoom

● Answering Skype for Business / Zoom calls:

- (1) Press the Call pick-up button to answer the call.

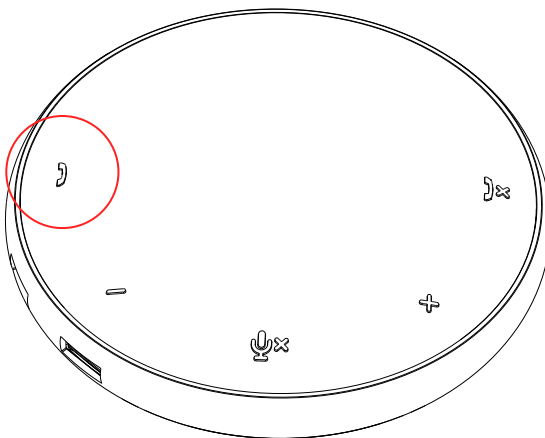

● Making Skype for Business calls

- (1) Press the Call pick-up button to bring Skype for Business on the main screen.
- (2) Initiate a call through the Skype for Business application on your computer.

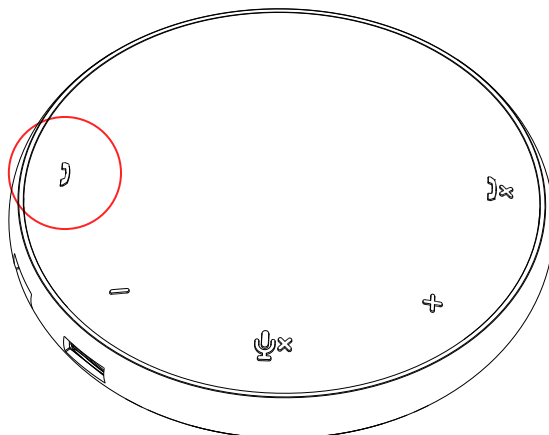

● Making Zoom calls

- (1) Initiate the call via the Zoom app.

- Adjusting the volume

- (1) Press the Volume up button to increase the volume. An audio prompt tone can be heard when press Volume up button.
- (2) Press the Volume down button to decrease the volume. An audio prompt tone can be heard when press Volume down button.

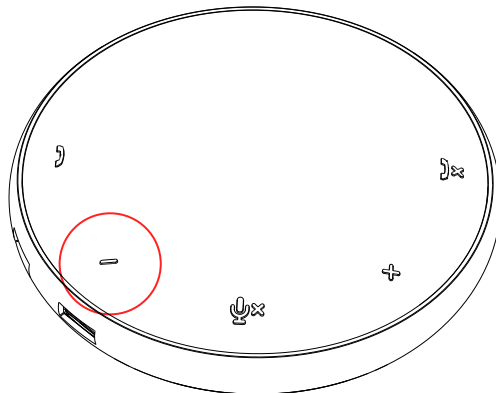
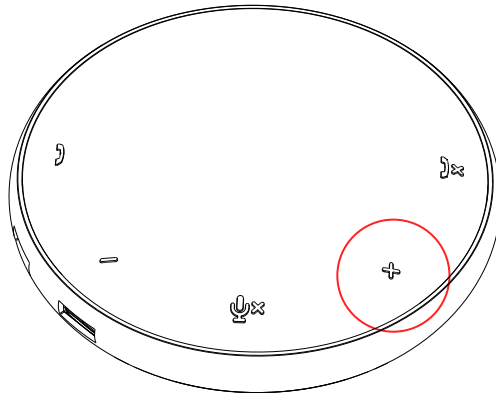

6. Operation behavior on Button and LED

- When powered up, top center LED will light up in white.

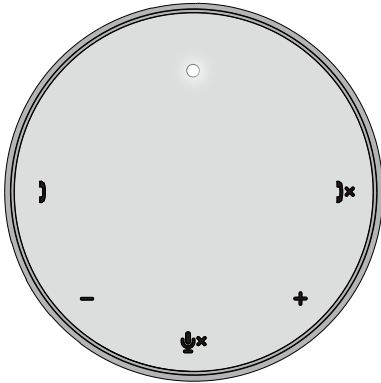

- Incoming call:
During incoming call, call pickup LED will blink in green, Call reject LED will blink in red.

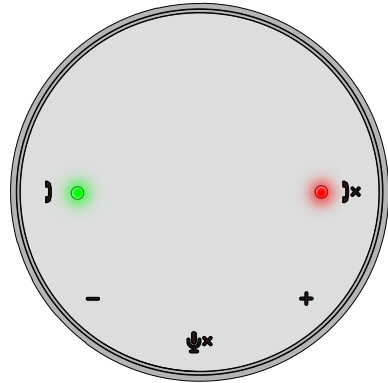

- During call:
Top center LED will change to green.

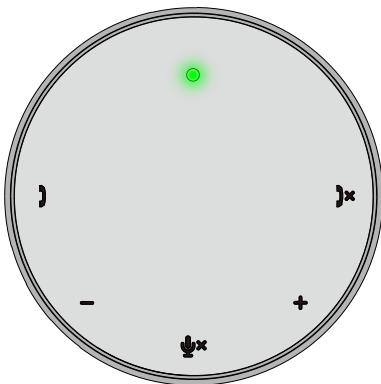

- Microphone muted
When microphone is muted, all LEDs will light up in red and stay red until microphone is unmuted.

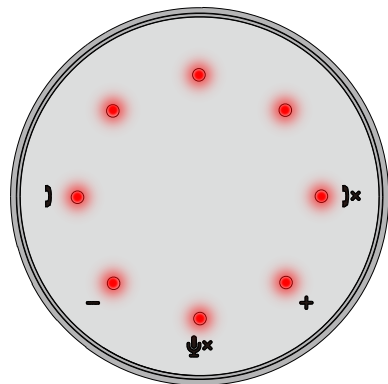

- **Adjusting volume:**

When adjusting volume, the ring of LEDs will temporarily light up in white to indicate volume level. When volume up is pressed, LED will light up in clockwise direction. When volume down is pressed, LED will go off in anti-clockwise direction.

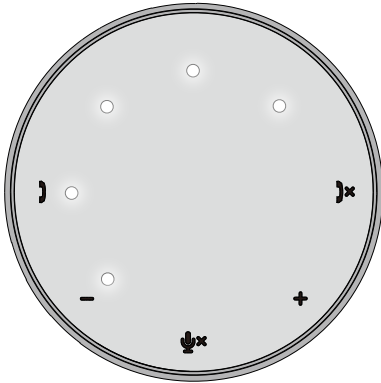

- **Hanging up a call:**

When a call ends, center top LED will return from green to white.

For Zoom, press "Leave Meeting" from the app.

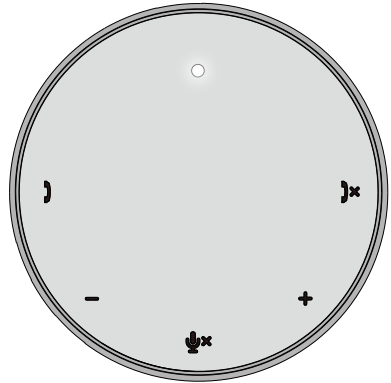

7. Connect peripherals to MH3021P

MH3021P can only support one video at one time, on a first cum first served basis.

When two video ports are plugged at the same time, the priority will be given to HDMI video port.

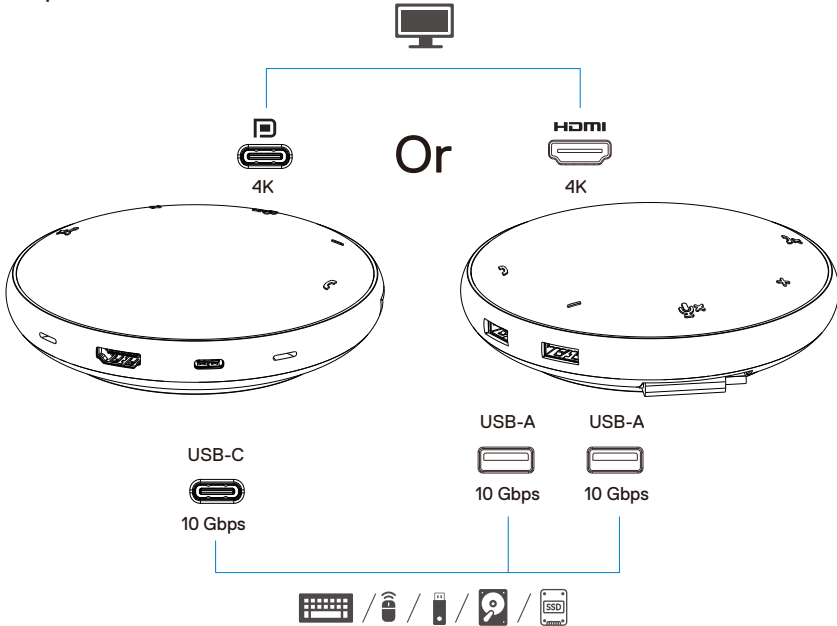

Video port

Connect an external display or a projector.



USB-C and USB-A ports

Connect peripherals such as keyboards, mice, and external storage devices.



NOTE: When MH3021P is connected to the Thunderbolt or 15W USB-C port power on your computer, the downstream USB-A and USB-C ports will work as below combination:

2X / / + 1X /

3X / /



NOTE: When MH3021P is connected to the 7.5W USB-C port power on your computer, the downstream USB-A and USB-C ports will work as below combination:

3X / /

Troubleshooting

Problems	Possible solutions
MH3021P is not working on the USB-A port on your computer	MH3021P is compatible only with the USB-C port on your computer. Thunderbolt port or USB-C (DisplayPort Alt Mode) port.
Multiple displays are not working	The MH3021P supports single display out. You can only connect a peripheral to the HDMI port, or USB-C monitor at a time.
Not able to utilize all the USB ports at the same time when MH3021P is connected to notebook without external power source	If you connect MH3021P to a Thunderbolt or 15 W USB-C (DisplayPort Alt Mode) port on your computer, you can use one video output, speakerphone, and the low powered USB devices like: mice, presentation clicker or RF dongle, and possibly the external hard disk drive. If you connect MH3021P to a 7.5 W USB-C (DisplayPort Alt Mode) port on your computer, you can use one video out along with low powered devices like presentation clicker/RF dongle.
Unable to read and write to an external SSD/HDD and optical (CD/DVD/Blu-ray) drive when connected to MH3021P	<ul style="list-style-type: none"> Some external SSD/HDD/Optical drives require higher power than what your MH3021P can support. It is recommended that you connect external SSD/HDD/Optical drive to your computer directly.
Power Surge message pops up "Unknown USB Device needs more power than the port can supply" when connecting a peripheral to the MH3021P	<ul style="list-style-type: none"> The peripheral you connected to MH3021P needs more power. Disconnect other peripherals connected to MH3021P. For high-power consumption peripherals, it is recommended to connect the peripheral to your computer directly. All devices that are connected to the USB-A / USB-C port of MH3021P will be disconnected automatically when the power surge message pops up. You can remove the last connected USB device.
Resolution on the monitor is lower than 4K 60 Hz when connected to the HDMI or Type-C port of MH3021P	<ul style="list-style-type: none"> Check to ensure the monitor is capable to support 4K60Hz. The 4K resolution at 60 Hz is supported on computers that have DisplayPort 1.3 or later (HBR3) with a display that is capable of 4K resolution at 60 Hz. On computers that support below DisplayPort 1.3, the maximum resolution supported is 4K at 30 Hz.
MH3021P is not charging your computer through the USB-C port I see a yellow bang icon on the battery status icon	<ul style="list-style-type: none"> MH3021P supports 90W max Power Delivery. The minimal power requirement for charging is platform dependent. MH3021P reserves 15W, so your system gets 15W less from the power source. You may observe a slow charging message/icon because of this. Recommended to use higher rating power adapter for optimal charging.
No video on the monitor attached to MH3021P	<ul style="list-style-type: none"> MH3021P only support single monitor. Check the video connection cables. Disconnect the peripheral from MH3021P, wait for 10 seconds then connect the peripheral.
Video / Audio performance issues	Check/update system BIOS, graphic driver and audio driver for newer version. Check/update system Thunderbolt firmware and driver for newer version.
Update your system's BIOS and MH3021P firmware	<ul style="list-style-type: none"> Please update your system's BIOS, graphics and drivers from https://www.dell.com/support/drivers Please update you MH3021P FW from https://www.dell.com/support/drivers Need to connect MH3021P to your computer before update FW.
Dell Display Manager (DDM) is not working	Check/Update system BIOS / Graphic driver and install Dell Display Manager (DDM) Monitor application. https://www.dell.com/support/home/drivers/driversdetails?driverid=6WGWY

MH3021P button behavior on some popular communication software	<ul style="list-style-type: none"> MH3021P buttons work well with Skype for Business and Zoom. Other communication SW, you can access call controls via communication software UI. 																																																												
	<table border="1"> <thead> <tr> <th>UC platforms</th> <th>Mute/ Unmute</th> <th>Call Accept</th> <th>Call End/Reject</th> <th>Volume Up</th> <th>Volume Down</th> </tr> </thead> <tbody> <tr> <td>Zoom</td> <td>OK</td> <td>OK</td> <td>OK*</td> <td>OK</td> <td>OK</td> </tr> <tr> <td>Skype for Business</td> <td>OK</td> <td>OK</td> <td>OK</td> <td>OK</td> <td>OK</td> </tr> <tr> <td>Microsoft Teams</td> <td>OK</td> <td>X</td> <td>X</td> <td>OK</td> <td>OK</td> </tr> <tr> <td>Google Hangouts</td> <td>OK</td> <td>X</td> <td>X</td> <td>OK</td> <td>OK</td> </tr> <tr> <td>Cisco Webex</td> <td>OK</td> <td>X</td> <td>X</td> <td>OK</td> <td>OK</td> </tr> <tr> <td>FaceTime</td> <td>OK</td> <td>X</td> <td>X</td> <td>OK</td> <td>OK</td> </tr> <tr> <td>Slack</td> <td>OK</td> <td>X</td> <td>X</td> <td>OK</td> <td>OK</td> </tr> <tr> <td>GoToMeeting</td> <td>OK</td> <td>X</td> <td>X</td> <td>OK</td> <td>OK</td> </tr> <tr> <td>BlueJeans</td> <td>OK</td> <td>X</td> <td>X</td> <td>OK</td> <td>OK</td> </tr> </tbody> </table>	UC platforms	Mute/ Unmute	Call Accept	Call End/Reject	Volume Up	Volume Down	Zoom	OK	OK	OK*	OK	OK	Skype for Business	OK	OK	OK	OK	OK	Microsoft Teams	OK	X	X	OK	OK	Google Hangouts	OK	X	X	OK	OK	Cisco Webex	OK	X	X	OK	OK	FaceTime	OK	X	X	OK	OK	Slack	OK	X	X	OK	OK	GoToMeeting	OK	X	X	OK	OK	BlueJeans	OK	X	X	OK	OK
	UC platforms	Mute/ Unmute	Call Accept	Call End/Reject	Volume Up	Volume Down																																																							
	Zoom	OK	OK	OK*	OK	OK																																																							
	Skype for Business	OK	OK	OK	OK	OK																																																							
	Microsoft Teams	OK	X	X	OK	OK																																																							
	Google Hangouts	OK	X	X	OK	OK																																																							
	Cisco Webex	OK	X	X	OK	OK																																																							
	FaceTime	OK	X	X	OK	OK																																																							
	Slack	OK	X	X	OK	OK																																																							
GoToMeeting	OK	X	X	OK	OK																																																								
BlueJeans	OK	X	X	OK	OK																																																								
<p>* Call end has 2 different states</p> <ol style="list-style-type: none"> Reject/Decline call - Can be done via End Call button on speakerphone End an ongoing call - Can be done ONLY via Zoom App 																																																													
My accept call / end call button does not work on MH3021P for Zoom Possible Solution	If multiple conferencing applications are installed in the same IT environment or installed and used on same PC, you may not be able to accept / end call by MH3021P. Recommend to answer incoming call /reject call by application's interface.																																																												
Video on the attached monitor is distorted or corrupted	<ul style="list-style-type: none"> Check the video connection cables. Check and update the video resolution under Settings > Display > Display resolution 																																																												
Video on the attached monitor is not displayed in extended mode	<ul style="list-style-type: none"> Change the setting under Settings > Display > Multiple displays Switch modes by pressing the Windows Key  + P. 																																																												
The Echo can be heard during the call	<ul style="list-style-type: none"> MH3021P has the Echo cancellation feature, it will help the user at the other end of the call to reduce the echo. If you hear echo in your device, it may be because of the other end user's device. Their device may be worse in the Echo Cancellation function. 																																																												
Speaker has no sound output from MH3021P	<ul style="list-style-type: none"> After connecting, go to the audio sound settings for your computer and select the MH3021P as the playback device. Check if MH3021 is connecting to computer correctly. Ensure that MH3021P volume is not set to 0%. 																																																												
Microphone does not function on MH3021P	<ul style="list-style-type: none"> After connecting, go to the sound settings for your computer and select the Dell MH3021 as the recording device. 																																																												
Can't make the phone call or pick the incoming call in device button via Line, WhatsApp and Wechat?	<ul style="list-style-type: none"> MH3021P answer call and end/reject call buttons only support "Skype for Business" and "Zoom". You can operate the answer or end/reject call via communication software UI. 																																																												
Abnormal sound	<ul style="list-style-type: none"> Clear any obstructions between MH3021P and the user. Re-plug Dell MH3021P with your computer again. 																																																												
Volume is too low	<ul style="list-style-type: none"> Clear any obstructions between MH3021P and the user. Turn the volume to a higher level by pressing the volume up button or control by communication software. Press volume setting on windows and increase the volume. 																																																												

Skype for Business show "This call is on hold"

• During the call by Skype for Business. The call may be on hold (not disconnect) in some operation conditions (press any button, connect additional audio device, Electro-Static discharge or other unexpected behaviors), the skype for business may show the message "This call is on hold." to ask you if you want to resume the call. You can press "Resume Call" icon to continual the call.

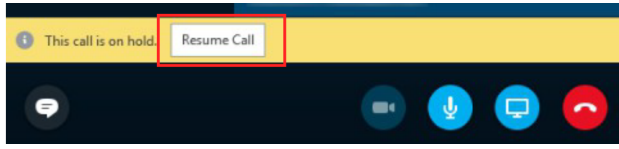

Set your MH3021P as default sound device in Windows 10

• You can follow steps below:
1. Open Settings.
2. Go to System - Sound.
3. On the right, select the required device in the drop down list Choose your output device.
a. Set output device

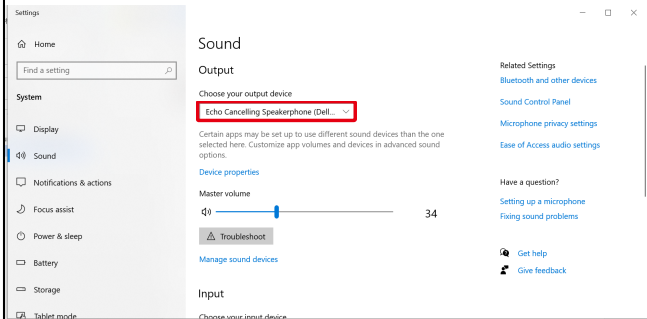

b. Set input device

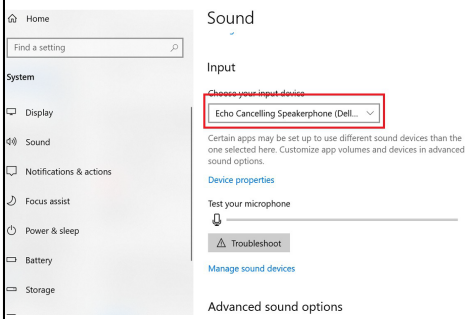

Set the Default Audio Device with the Sound flyout

- You can follow steps below:
 1. Click on the sound volume icon in the system tray.
 2. Click on the up arrow in the sound flyout.

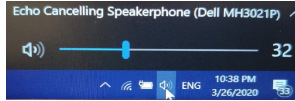

3. Choose the desired audio device from the list.

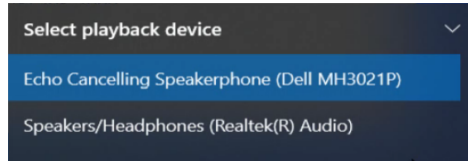

Set the default audio device with the classic Sound applet

- To open the classic Sound options in Windows 10, you can follow steps below:
 1. Press Win + R to open the Run dialog.
 2. Type or copy-paste the following command:
Mmsys.cpl

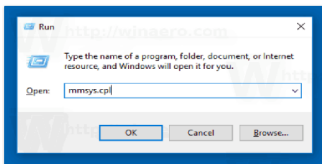

3. Press the Enter key. This will open the Sounds applet directly.

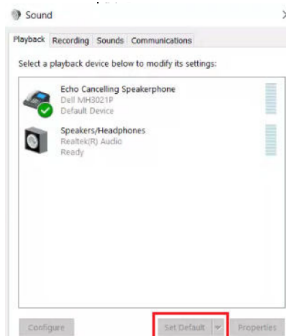

4. Select the desired device in the list and click on the Set Default button.

Specifications	
Upstream input	USB-C with DP alt mode
Downstream data ports	<ul style="list-style-type: none"> •Two USB 3.1 Gen 2 Type-A port •One USB 3.1 Gen 2 Type-C port
Downstream Video out ports and resolutions supported	Single video out from one of the two ports: <ul style="list-style-type: none"> • One USB-C(DP) port (3840 x 2160 max)/60 Hz • One HDMI 2.0 port (3840 x 2160 max)/60 Hz 4K/60Hz only supported on computer with HBR3 feature.
Audio	<ul style="list-style-type: none"> •Two Built-in Omnidirectional Microphones •Speaker
Button and LED indication	<ul style="list-style-type: none"> • Button: Answer call, End call/Reject call, Volume up, Volume down, Microphone mute • LED: White, Red, Green

System requirements	
Supported operating system	Win10 64-bit
Operating temperature	0~35°C

Statutory information

Warranty

Limited warranty and return policies

Dell-branded products carry a 1-year limited hardware warranty. If purchased together with a Dell system, it will follow the system warranty.

For U.S. customers:

This purchase and your use of this product are subject to Dell's end user agreement, which you can find at www.dell.com/terms. This document contains a binding arbitration clause.

For European, Middle Eastern and African customers:

Dell-branded products that are sold and used are subject to applicable national consumer legal rights, the terms of any retailer sale agreement that you have entered into (which will apply between you and the retailer) and Dell's end user contract terms.

Dell may also provide an additional hardware warranty—full details of the Dell end user contract and warranty terms can be found by going to www.dell.com, selecting your country from the list at the bottom of the “home” page and then clicking the “terms and conditions” link for the end user terms or the “support” link for the warranty terms.

For non-U.S. customers:

Dell-branded products that are sold and used are subject to applicable national consumer legal rights, the terms of any retailer sale agreement that you have entered into (which will apply between you and the retailer) and Dell's warranty terms. Dell may also provide an additional hardware warranty —full details of Dell's warranty terms can be found by going to www.dell.com, selecting your country from the list at the bottom of the “home” page and then clicking the “terms and conditions” link or the “support” link for the warranty terms.



NOTE: Warranty for pouch is not covered.