



Dell™ KB5220W-C Chrome Wireless Keyboard

User's Guide

Marketing Model: KB5220W-C
Regulatory Model: KM713, RG-1216
Regulatory Type: Keyboard, Dongle



-  **NOTE:** A NOTE indicates important information that helps you make better use of your computer.
-  **CAUTION:** A CAUTION indicates potential damage to hardware or loss of data if instructions are not followed.
-  **WARNING:** A WARNING indicates a potential for property damage, personal injury, or death.

Copyright © 2019 Dell Inc. or its subsidiaries. All rights reserved. Dell, EMC, and other trademarks are trademarks of Dell Inc. or its subsidiaries. Other trademarks may be trademarks of their respective owners.

2019 – 09

Rev. A00

Contents

Setup	4
System Requirements	4
Contents of the Box	4
Setting Up Your Wireless Keyboard	5
Function keys	6
Troubleshooting	8
Specifications.	9
Limited Warranty and Return Policies	10
For U.S. customers.	10
For European, Middle Eastern and African customers	10
For non-U.S. customers	10

Setup

System Requirements

- One USB port (for the USB receiver)
- Google Chrome

Contents of the Box

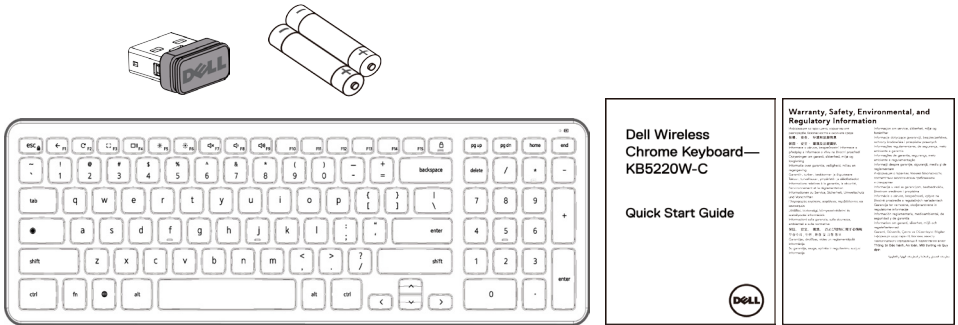

- One wireless keyboard
- One USB receiver
- Two batteries
- Product documentation

 **NOTE:** The USB receiver may be pre-installed on your computer.

 **NOTE:** The documents that shipped with the keyboard and mouse may vary based on your region.

Setting Up Your Wireless Keyboard

1. Install the two AAA batteries in your keyboard.

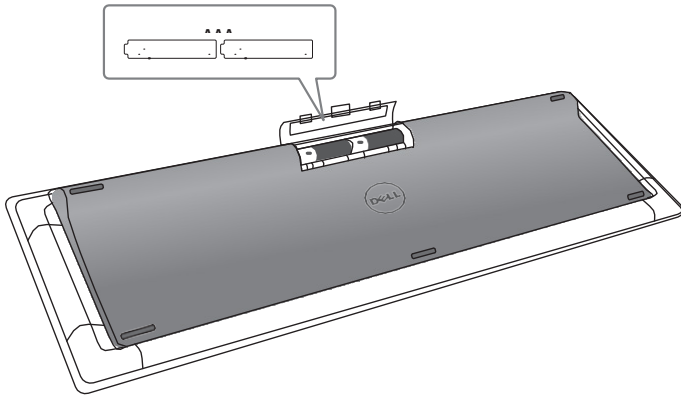

2. Connect the USB receiver to the computer.

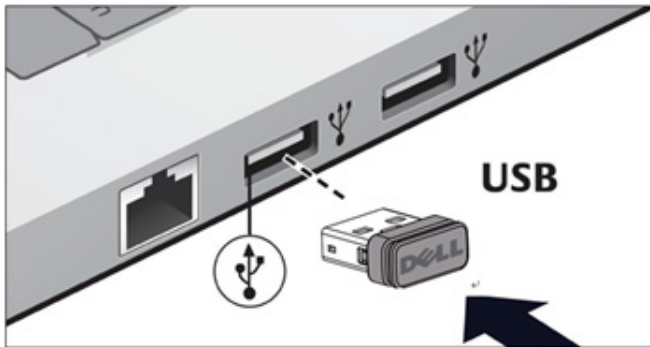

If your keyboard or mouse is not working, see the Troubleshooting section.



Function keys

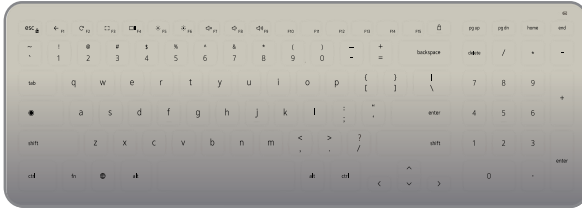

Back page



Reload page



Reload page



Overview



Decrease brightness



Increase brightness



Mute



Decrease volume



Increase volume



Screen Lock
(Pressed and hold for 2s to activate Lock screen)



Language Switch



Screen Toggle
(To execute lower F12 function, press Fn +F12)

Function keys

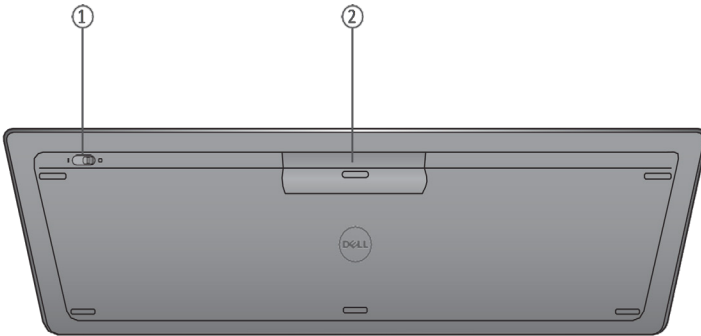

1. Power switch
2. Battery compartment



Troubleshooting

If you have problems with your keyboard:

- Check if the batteries are inserted in the correct orientation.
- Check if the keyboard's power switch is set to "On".
- Remove and reinstall the batteries. The power status light turns on (solid white) for about 15 seconds and then turns off.
- Remove and reconnect the USB receiver on your computer.
- Connect the USB receiver into another USB port on your computer.
- Restart your computer.

Specifications

General

Model number	KB5220W-C
Connection type	2.4 GHz wireless technology
Supported operating systems	Google Chrome
Rollover	Pseudo N-key rollover capability
Key mechanism	Scissor

Electrical

Operating voltage	2.05 V to 3.2 V
Battery life	Approximately 12 months
Battery required	Two AAA Alkaline

Environmental

Operating temperature	0 °C to 40 °C
Storage temperature	-40 °C to 65 °C
Operating humidity	90% maximum Relative Humidity, non condensing
Storage humidity	95% maximum Relative Humidity, non condensing

2.4 GHz Wireless

Radio transmission	Bi-directional communication (Transceiver)
Range	Up to 10 m



Limited Warranty and Return Policies

Dell-branded products carry a 1-year limited hardware warranty.

If purchased together with Dell system, it will follow the system warranty.

For U.S. customers:

This purchase and your use of this product are subject to Dell's end user agreement, which you can find at [**www.dell.com/terms**](http://www.dell.com/terms). This document contains a binding arbitration clause.

For European, Middle Eastern and African customers:

Dell-branded products that are sold and used are subject to applicable national consumer legal rights, the terms of any retailer sale agreement that you have entered into (which will apply between you and the retailer) and Dell's end user contract terms. Dell may also provide an additional hardware warranty – full details of the Dell end user contract and warranty terms can be found by going to [**www.dell.com**](http://www.dell.com), selecting your country from the list at the bottom of the “home” page and then clicking the “terms and conditions” link for the end user terms or the “support” link for the warranty terms.

For non-U.S. customers:

Dell-branded products that are sold and used are subject to applicable national consumer legal rights, the terms of any retailer sale agreement that you have entered into (which will apply between you and the retailer) and Dell's warranty terms. Dell may also provide an additional hardware warranty – full details of Dell's warranty terms can be found by going to [**www.dell.com**](http://www.dell.com), selecting your country from the list at the bottom of the “home” page and then clicking the “terms and conditions” link or the “support” link for the warranty terms.