



# Alienware 510M RGB Gaming Mouse

## User Guide

Mouse Model: AW510M  
Regulatory Model: AW510M

A L I E N W A R E™ 

# Notes, cautions, and warnings

-  **NOTE:** A NOTE indicates important information that helps you make better use of your computer.
-  **CAUTION:** A CAUTION indicates potential damage to hardware or loss of data if instructions are not followed.
-  **WARNING:** A WARNING indicates a potential for property damage, personal injury, or death.

**Copyright © 2019-2020 Dell Inc. or its subsidiaries. All rights reserved.** Dell, EMC, and other trademarks are trademarks of Dell Inc. or its subsidiaries. Other trademarks may be trademarks of their respective owners.

2020 – 08

Rev. A01

# Contents

<b>What's in the box</b>	<b>4</b>
<b>Features</b>	<b>5</b>
Adjustable DPI	5
Scrolling count	6
<b>Setting up your gaming mouse</b>	<b>6</b>
Connecting the mouse	6
<b>Alienware Command Center (AWCC) Application</b>	<b>8</b>
Installing AWCC through Windows Update	8
Installing AWCC from the Dell Support website	8
<b>Troubleshooting</b>	<b>9</b>
<b>Statutory Information</b>	<b>12</b>
<b>Warranty</b>	<b>12</b>
Limited warranty and return policies	12
For U.S. customers:	12
For European, Middle Eastern and African customers:	12
For non-U.S. customers:	12

# What's in the box

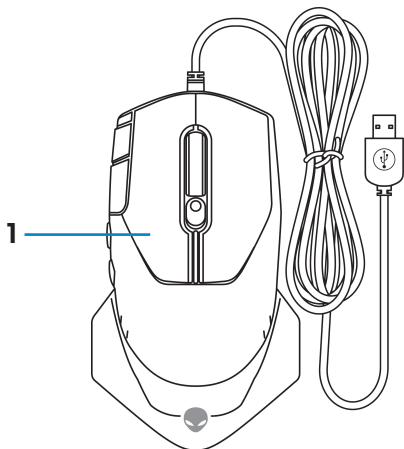

1. Mouse

2. Documents

# Features

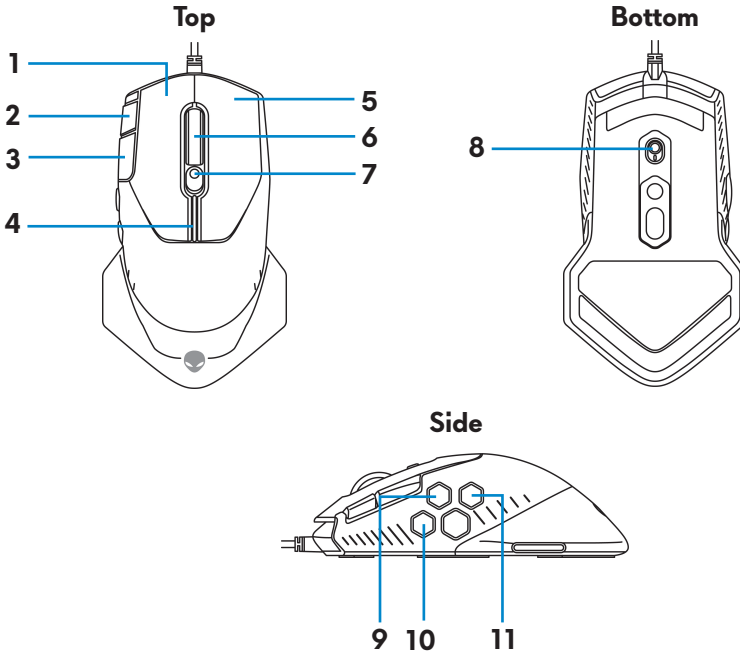

- |                           |                                   |
|---------------------------|-----------------------------------|
| 1. Left button            | 2. Continuous scroll up           |
| 3. Continuous scroll down | 4. DPI indicators                 |
| 5. Right button           | 6. Scroll wheel                   |
| 7. DPI adjustment slider  | 8. Scroll wheel adjustment switch |
| 9. Forward button         | 10. DPI clutch button             |
| 11. Backward button       |                                   |

## Adjustable DPI

Press the DPI adjustment button to instantly change the mouse tracking resolution. DPI setting is indicated by the DPI indicator color. The default five DPI settings available are as follows:

- 800: Blue (■)
- 1800: Green (■) (Out-of-box default)
- 3500: Yellow (■)
- 9000: Orange (■)
- 16000: Red (■)

You can change the default DPI settings and customize the DPI stages and LED colors with the Alienware Command Center (AWCC) application.

### Scrolling count

Push the scroll wheel adjustment switch up to set the number of steps to 12 or down to set the number of steps to 24.

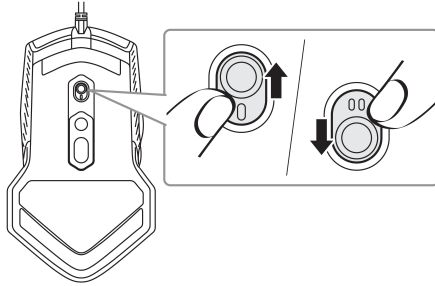

## Setting up your gaming mouse

### Connecting the mouse

1. Turn the mouse over.

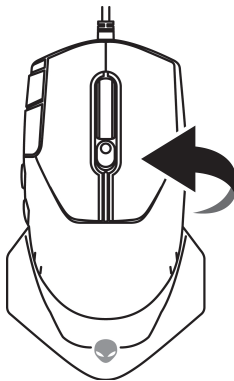

2. Remove the protective sheet.

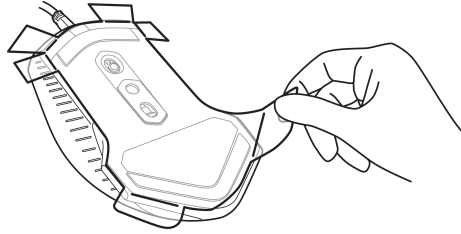

3. Connect the mouse USB cable to an available USB A port on your desktop or laptop.

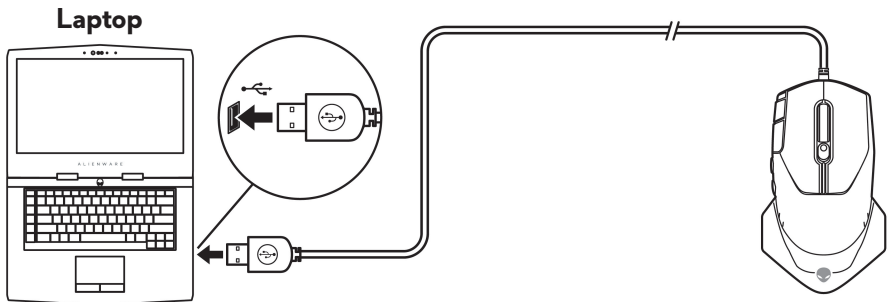
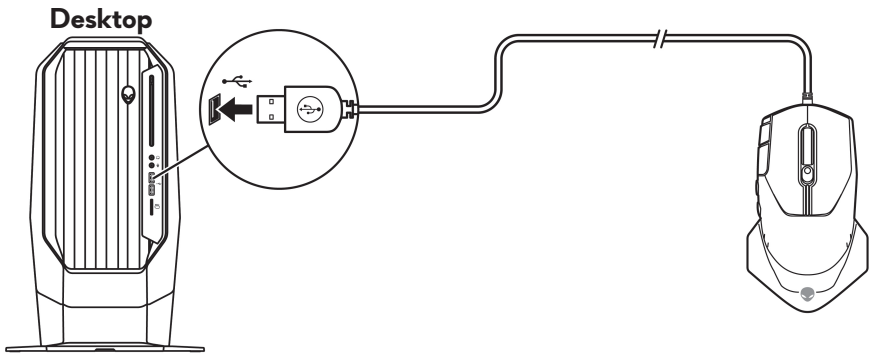

# Alienware Command Center (AWCC) Application

Alienware Command Center (AWCC) application provides a single interface to customize and enhance the gaming experience.

 **NOTE: For more information, see the Alienware Command Center (AWCC) application Online Help.**

## Installing AWCC through Windows Update

1. Connect your Alienware peripheral to your computer through the USB port. The AWCC application is downloaded and installed automatically. AWCC installation may take up to 10 minutes to complete.
2. Navigate to the program folder to ensure that the AWCC installation is complete.
3. Launch AWCC and perform the following steps to download the additional software components:
  - In the **Settings** window, click **Windows Update**, and then click **Check for updates** to check the Alienware driver update progress.
  - If the driver update is not responding in your computer, install AWCC from the Dell Support website.

## Installing AWCC from the Dell Support website

1. Download the latest version of the following applications from [www.dell.com/support/drivers](http://www.dell.com/support/drivers).
  - Alienware Command Center
  - Alienware Gaming Peripheral driver
2. Navigate to the folder where you saved the setup files.
3. Double-click the setup file and follow the on-screen instructions to install the application.

 **NOTE: You can customize the mouse features and lighting effects by using the Alienware Command Center (AWCC) application.**



# Troubleshooting

<b>Problems</b>	<b>Possible solutions</b>
Mouse is not functioning	<ol style="list-style-type: none"><li>1. Connect the mouse USB cable to another USB A port. A notification may appear indicating that the driver installation is in progress. If so, wait until a notification to appear indicating that the drivers are installed before you use the mouse.</li><li>2. Restart the computer.</li></ol>
Mouse lights do not turn on	<ol style="list-style-type: none"><li>1. Press any button to wake the mouse from sleep mode.</li><li>2. Connect the mouse USB cable to another USB A port. A notification may appear indicating that the driver installation is in progress. If so, wait until a notification to appear indicating that the drivers are installed before you use the mouse.</li><li>3. Restart the computer.</li></ol>
Mouse is not running based on the configuration selected in the Alienware Command Center (AWCC) application.	<ol style="list-style-type: none"><li>1. Ensure that the Alienware Command Center (AWCC) application is installed on your computer.</li><li>2. Open the Alienware Command Center (AWCC) application and ensure that the selected configuration is set up and saved.</li></ol>

## Problems

Resolving cursor issues

## Possible solutions

1. Connect the mouse USB cable to another USB A port. A notification may appear indicating that the driver installation is in progress. If so, wait until a notification to appear indicating that the drivers are installed before you use the mouse.
2. Ensure that the sensor is not obstructed or dirty.
3. Glass or very smooth glossy surfaces are not suitable for the mouse sensor to capture movement. Using a dark colored fabric mouse pad can improve the tracking.
4. Save any data, close any open program(s), and then restart the laptop/desktop. When you do not have another mouse or touchscreen, you may have to hold the power button down for at least 15 seconds to turn the laptop/desktop off. You may lose any data that is not saved.

Resolving mouse button issues

1. Ensure that there is nothing preventing the mouse buttons from moving. Most mouse buttons make a clicking noise when pressed down.
2. Connect the mouse USB cable to another USB A port. A notification may appear indicating that the driver installation is in progress. If so, wait until a notification to appear indicating that the drivers are installed before you use the mouse.

**Problems**

**Possible solutions**

Resolving mouse button issues  
(continued)

**3.** Save any data, close any open program(s), and then restart the laptop/desktop. When you do not have another mouse or touchscreen, you may have to hold the power button down for at least 15 seconds to turn the laptop/desktop off. You may lose any data that is not saved.

Troubleshooting a slow moving cursor

- 1.** Ensure that the sensor is not obstructed or dirty.
- 2.** Glass or very smooth glossy surfaces are not suitable for the mouse sensor to capture movement. Using a dark colored fabric mouse pad can improve the tracking.use pad can improve the tracking.
- 3.** Change the mouse settings to adjust the pointer speed.  
Click on the tab that matches the Operating System (OS) installed on your laptop/desktop and perform the steps within that section to change the settings.
  - In the **Search** box, type `main.cpl`.
  - Click or tap `main.cpl` in the list of programs.
  - Click or tap the **Pointer Options** tab.
  - Move the slider under **Select a Pointer Speed** to adjust the cursor speed to the desired level.
  - Click or tap **OK**.

Troubleshooting lift off distance (LOD) surface calibration issues

The LOD surface calibration depends on the surface characteristics and may not work on all surfaces.  
Using a dark colored fabric mouse pad might improve LOD calibration.

# Statutory Information

## Warranty

### Limited warranty and return policies

Dell-branded products carry a two-year limited hardware warranty. If purchased together with Dell system, it will follow the system warranty.

#### **For U.S. customers:**

This purchase and your use of this product are subject to Dell's end user agreement, which you can find at <https://www.dell.com/terms>. This document contains a binding arbitration clause.

#### **For European, Middle Eastern and African customers:**

Dell-branded products that are sold and used are subject to applicable national consumer legal rights, the terms of any retailer sale agreement that you have entered into (which will apply between you and the retailer) and Dell's end user contract terms.

Dell may also provide an additional hardware warranty – full details of the Dell end user contract and warranty terms can be found by going to <https://www.dell.com/terms>, selecting your country from the list at the bottom of the "home" page and then clicking the "terms and conditions" link for the end user terms or the "support" link for the warranty terms.

#### **For non-U.S. customers:**

Dell-branded products that are sold and used are subject to applicable national consumer legal rights, the terms of any retailer sale agreement that you have entered into (which will apply between you and the retailer) and Dell's warranty terms. Dell may also provide an additional hardware warranty – full details of Dell's warranty terms can be found by going to <https://www.dell.com/terms>, selecting your country from the list at the bottom of the "home" page and then clicking the "terms and conditions" link or the "support" link for the warranty terms.