

# **Simplified Service Manual–E2720HB**

**Version: 01**

**Date:2021/03/04**

## Content Index

<b>1. General Safety Instructions</b> .....	<b>3</b>
1.1 SAFETY: General Safety .....	3
1.2 SAFETY: General Power Safety .....	5
<b>2. Exploded view diagram with list of items</b> .....	<b>6</b>
<b>3. Wiring connectivity diagram</b> .....	<b>7</b>
<b>4. Disassembly and Assembly Procedures</b> .....	<b>8</b>
4.1 Disassembly SOP .....	8
4.2 Assembly SOP .....	12
<b>5. Trouble shooting instructions</b> .....	<b>15</b>

## 1. General Safety Instructions

Use the following safety guidelines to help ensure your own personal safety and to help protect your equipment and working environment from potential damage.

**NOTE: In this section, equipment refers to monitors.**

### IMPORTANT NOTICE FOR USE IN HEALTHCARE ENVIRONMENTS:

Dell products are not medical devices and are not listed under UL or IEC 60601 (or equivalent). As a result, they must not be used within 6 feet of a patient or in a manner that directly or indirectly contacts a patient

#### 1.1 SAFETY: General Safety

**WARNING:** To prevent the spread of fire, keep candles or other open flames away from this product at all times.

#### When setting up the equipment for use:

- Place the equipment on a hard, level surface. Leave 10.2 cm (4 in) minimum of clearance on all vented sides of the computer to permit the airflow required for proper ventilation.
- Restricting airflow can damage the computer or cause a fire.
- Do not stack equipment or place equipment so close together that it is subject to recirculated or preheated air.
- NOTE: Review the weight limits referenced in your computer documentation before placing a monitor or other devices on top of your computer.
- Ensure that nothing rests on your equipment's cables and that the cables are not located where they can be stepped on or tripped over.
- Ensure that all cables are connected to the appropriate connectors. Some connectors have a similar appearance and may be easily confused (for example, do not plug a telephone cable into the network connector).
- Do not place your equipment in a closed-in wall unit or on a bed, sofa, or rug.
- Keep your device away from radiators and heat sources.
- Keep your equipment away from extremely hot or cold temperatures to ensure that it is used within the specified operating range.
- Do not push any objects into the air vents or openings of your equipment. Doing so can cause fire or electric shock by shorting out interior components.
- Avoid placing loose papers underneath your device. Do not place your device in a closed-in wall unit, or on a soft, fabric surface such as a bed, sofa, carpet, or a rug.

### **When operating your equipment:**

- Do not use your equipment in a wet environment, for example, near a bath tub, sink, or swimming pool or in a wet basement.
- Do not use AC powered equipment during an electrical storm. Battery powered devices may be used if all cables have been disconnected.
- Do not spill food or liquids on your equipment.
- Before you clean your equipment, disconnect it from the electrical outlet. Clean your device with a soft cloth dampened with water. Do not use liquids or aerosol cleaners, which may contain flammable substances.
- Clean the monitor display with a soft, clean cloth and water. Apply the water to the cloth, then stroke the cloth across the display in one direction, moving from the top of the display to the bottom. Remove moisture from the display quickly and keep the display dry.
- Long-term exposure to moisture can damage the display. Do not use a commercial window cleaner to clean your display.
- If your equipment does not operate normally - in particular, if there are any unusual sounds or smells coming from it - unplug it immediately and contact an authorized dealer or service center.

### **Protecting Against Electrostatic Discharge**

Electrostatic discharge (ESD) events can harm electronic components inside your equipment. Under certain conditions, ESD may build up on your body or an object, such as a peripheral, and then discharge into another object, such as your computer. To prevent ESD damage, you should discharge static electricity from your body before you interact with any of your equipment's internal electronic components, such as a memory module. You can protect against ESD by touching a metal grounded object (such as an unpainted metal surface on your computer's I/O panel) before you interact with anything electronic. When connecting a peripheral (including handheld digital assistants) to your equipment, you should always ground both yourself and the peripheral before connecting it. In addition, as you work inside the equipment, periodically discharge any static charge your body may have accumulated.

### **You can also take the following steps to prevent damage from electrostatic discharge:**

- When unpacking a static-sensitive component from its shipping carton, do not remove the component from the antistatic packing material until you are ready to install the component. Just before unwrapping the antistatic package, be sure to discharge static electricity from your body.
- When transporting a sensitive component, first place it in an antistatic container or packaging.
- Handle all electrostatic sensitive components in a static-safe area. If possible, use antistatic floor pads and work bench pads.

## 1.2 SAFETY: General Power Safety

Observe the following guidelines when connecting your equipment to a power source:

- Check the voltage rating before you connect the equipment to an electrical outlet to ensure that the required voltage and frequency match the available power source.
- Do not plug the equipment power cables into an electrical outlet if the power cable is damaged
- Norway and Sweden: If this product is provided with a 3-prong power cable, connect the power cable to a grounded electrical outlet only.
- If you use an extension power cable, ensure that the total ampere rating of the products plugged in to the extension power cable does not exceed the ampere rating of the extension cable.
- If you must use an extension cable or power strip, ensure the extension cable or power strip is connected to a wall power outlet and not to another extension cable or power strip. The extension cable or power strip must be designed for grounded plugs and plugged into a grounded wall outlet.
- If you are using a multiple-outlet power strip, use caution when plugging the power cable into the power strip. Some power strips may allow you to insert a plug incorrectly. Incorrect insertion of the power plug could result in permanent damage to your equipment, as well as risk of electric shock and/or fire. Ensure that the ground prong of the power plug is inserted into the mating ground contact of the power strip.
- Be sure to grasp the plug, not the cable, when disconnecting equipment from an electric socket.

### If your equipment uses an AC adapter:

- Use only the Dell provided AC adapter approved for use with this device. Use of another AC adapter may cause a fire or explosion.
- NOTE: Refer to your system rating label for information on the proper adapter model approved for use with your device.
- Place the AC adapter in a ventilated area, such as a desk top or on the floor, when you use it to run the computer or to charge the battery. Do not cover the AC adapter with papers or other items that will reduce cooling; also, do not use the AC adapter inside a carrying case.
- The AC adapter may become hot during normal operation of your computer. Use care when handling the adapter during or immediately after operation.
- It is recommended that you lay the adapter on the floor or desk so that the green light is visible. This will alert you if the adapter should accidentally go off due to external effects. If for any reason the green light goes off, disconnect the AC power cord from the wall for a period of ten seconds, and then reconnect the power cord.
- Japan Only: Use only the Dell-provided AC power cable with the AC adapter. Use of any other power cable may damage the device or AC adapter or may present risk of fire or electric shock.

## 2. Exploded view diagram with list of items

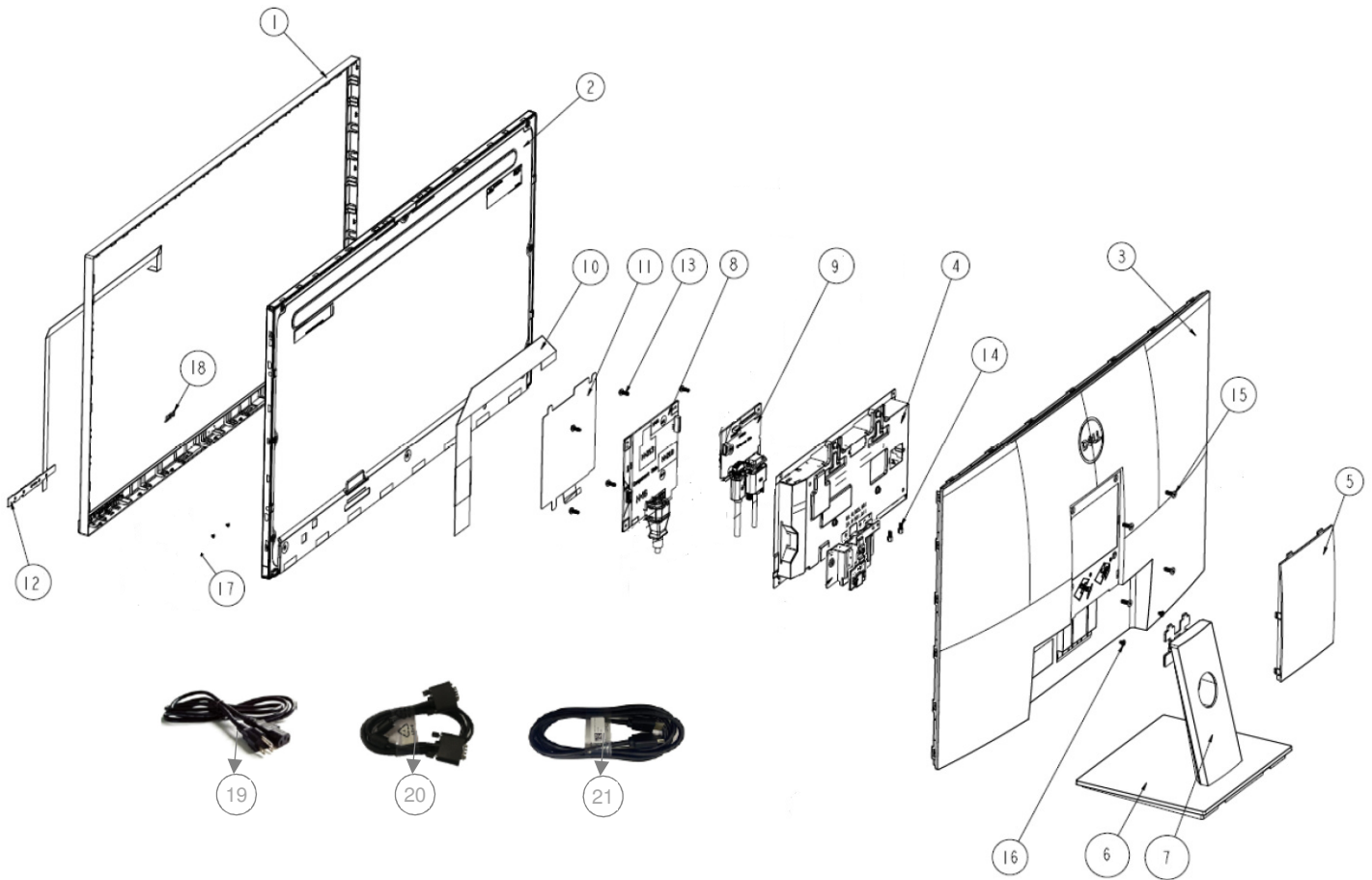

Item no	Description	Q'TY
1	ASSY BZL	1
2	Panel	1
3	ASSY RC	1
4	ASSY SHD MAIN	1
5	ASSY CVR VESA	1
6	ASSY BASE	1
7	ASSY CLMN	1
8	PCBA SPS BD	1
9	PCBA I/F BD	1
10	FFC LVDS	1
11	MYLAR PWR	1
12	PCBA CTRL BD	1
13	SCRW PH INT/TOO M3*9TP-S C-ZN	5
14	SCRW MACH STEEL HEX 4-40 NI	2
15	SCRW FPHM4*10L(7.7/1.6)B-ZNNY	4
16	SCRW M FPH M3*4L(6.5/1.2) B-ZN	2
17	SCRW TP-B FPH M2*2.4L ZN	3
18	LOGO DELL	1
19	Power cable	1
20	VGA cable	1
21	DP cable	1

### 3. Wiring connectivity diagram

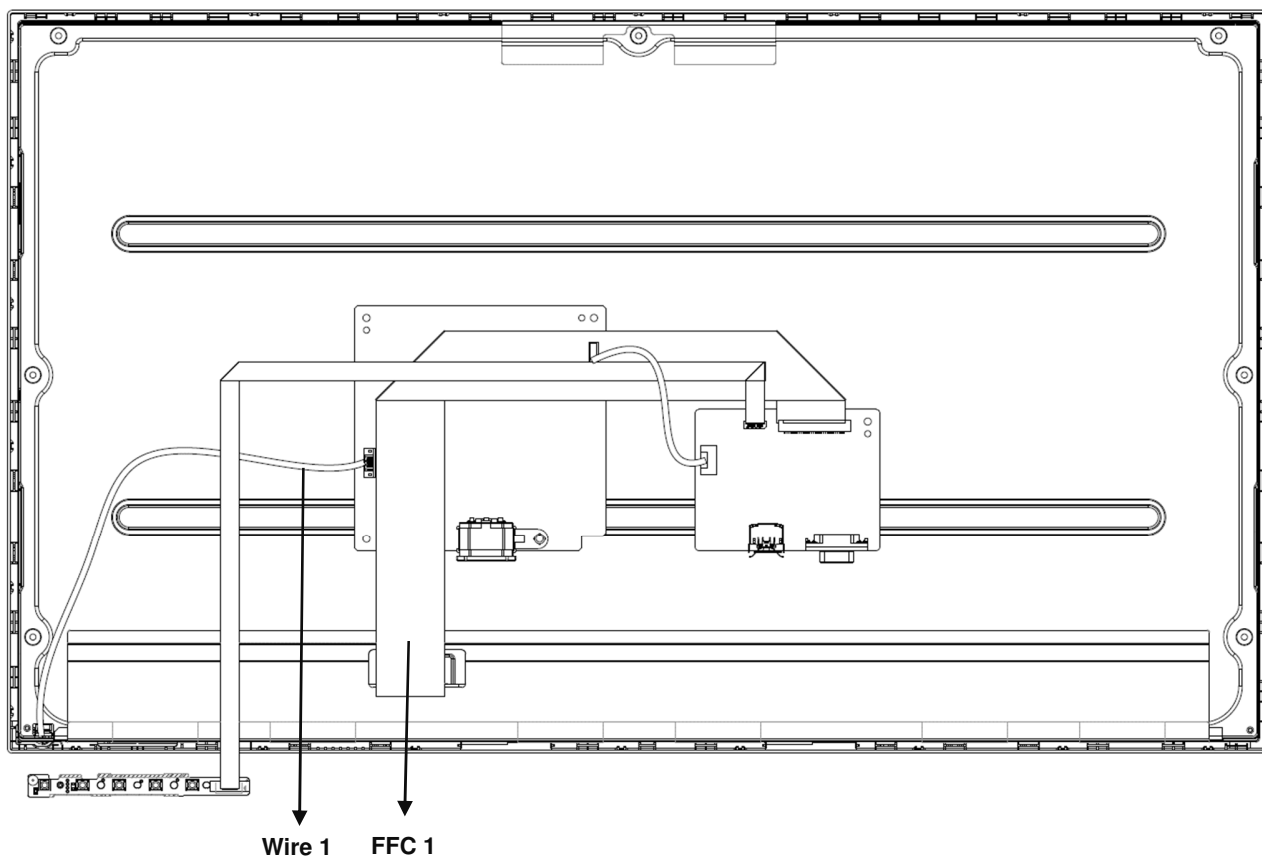

## 4. Disassembly and Assembly Procedures

### 4.1 Disassembly SOP

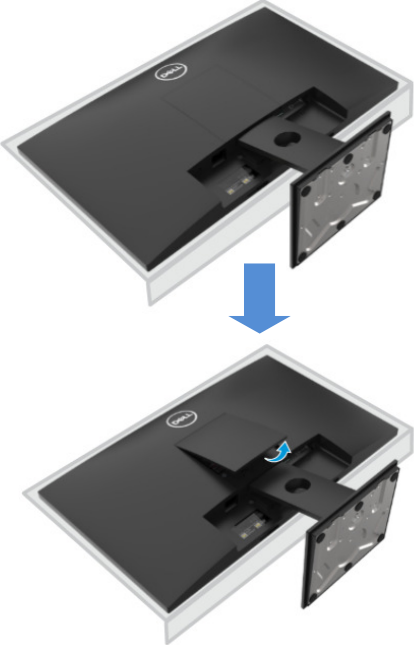
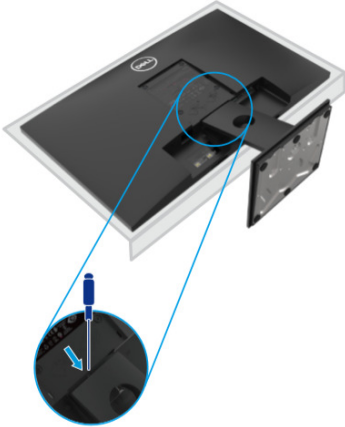

Preparation before disassembly

1. Clean the room for disassembly
2. Identify the area for monitor
3. Prepare the equipment, tool and material as bellow:
  - 1) Working table
  - 2) Philips-head screwdriver
  - 3) Hex-head screwdriver
  - 4) Glove
  - 5) Cleaning cloth
  - 6) ESD protection

Item	Picture	Operation	Tool	Notes
1		<ol style="list-style-type: none"> <li>1. Place the monitor on a soft cloth along the desk.</li> <li>2. Remove VESA cover to access the release button.</li> </ol>		
2		<ol style="list-style-type: none"> <li>1. Use a long and thin screwdriver to push the release latch located in a hole just above the stand.</li> <li>2. Once the latch is released, remove the base away from the monitor.</li> </ol>	Philips-head screwdriver	

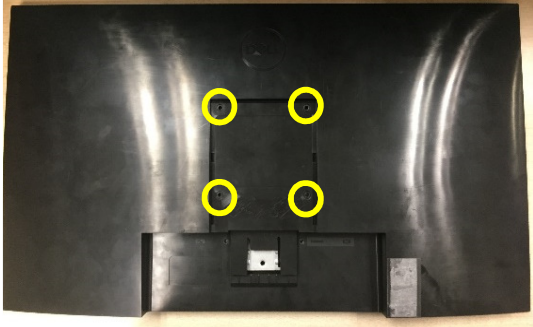
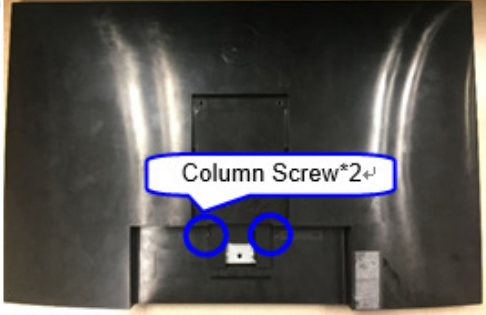

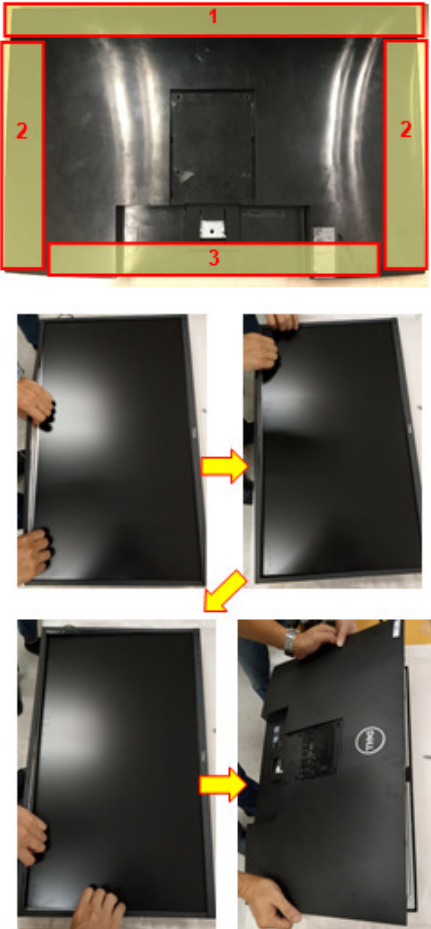
2		3. Loosen the stand base thumbscrew fully to remove the base from the riser.		
3		1. Unlock 4 screws on Rear Cover	Philips-head screwdriver  Torsion of screw: 8~10Kg	
4		1. Unlock 2 CLMN screws	Philips-head screwdriver  Torsion of CLMN screw: 4.5±0.5Kg	

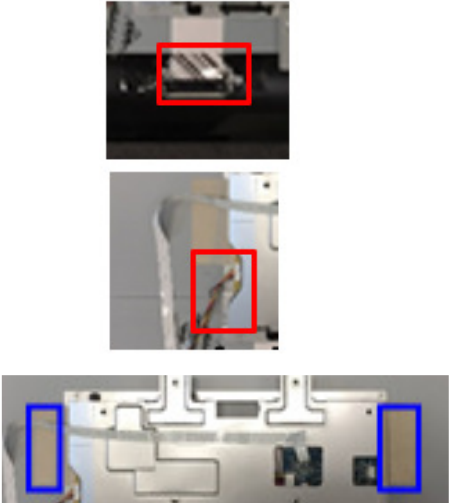
5		<ol style="list-style-type: none"> <li>1. Disassemble Rear Cover from the monitor</li> <li>2. Notice the disassembly order: <ol style="list-style-type: none"> <li>1) Disassemble the Top part</li> <li>2) Disassemble the Left / Right part</li> <li>3) Disassemble the Bottom part</li> <li>4) Remove RC from Bezel</li> </ol> </li> </ol>		
6		<ol style="list-style-type: none"> <li>1. Remove Control BD FFC cable from I/F BD</li> </ol>		
7		<ol style="list-style-type: none"> <li>1. Remove 2 tapes from LVDS cable and backlight wire</li> <li>2. Remove LVDS cable from panel</li> <li>3. Remove backlight wire from panel and SPS BD</li> <li>4. Remove 2 tape from Main SHD and panel</li> </ol>		

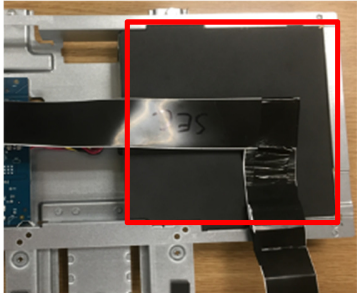
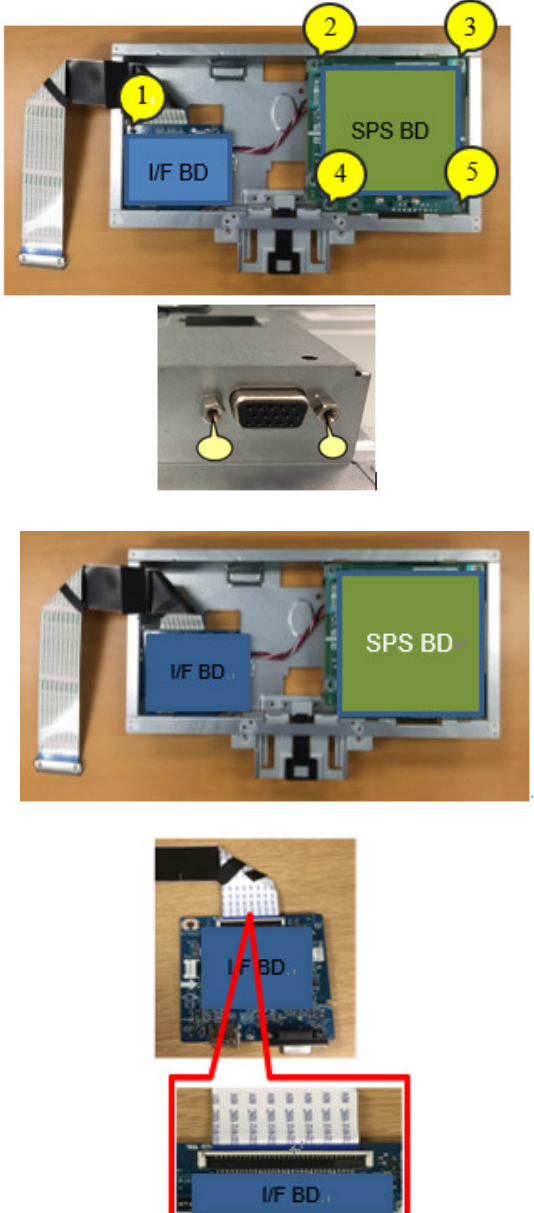
8		<ol style="list-style-type: none"> <li>1. Disassemble Safety Mylar from Main SHD</li> </ol>		
9		<ol style="list-style-type: none"> <li>1. Unlock 5 PCBA screws and 2 hex screws</li> <li>2. Disassemble SPS BD and I/F BD from Main SHD</li> <li>3. Remove SPS wire from I/F BD</li> <li>4. Remove LVDS cable from I/F BD</li> </ol>	<ol style="list-style-type: none"> <li>1. Philips-head screwdriver Torsion of PCB screw: <math>6.5 \pm 1.0 \text{ Kg}</math></li> <li>2. Hex-head screwdriver Torsion of hex screw: <math>5.0 \pm 0.6 \text{ Kg}</math></li> </ol>	

## 4.2 Assembly SOP

Preparation before assembly

1. Clean the room for disassembly
2. Identify the area for monitor
3. Prepare the equipment, tool and material as bellow:
  - 1) working table
  - 2) Philips-head screwdriver
  - 3) Hex-head screwdriver
  - 4) Glove
  - 5) Cleaning cloth
  - 6) ESD protection

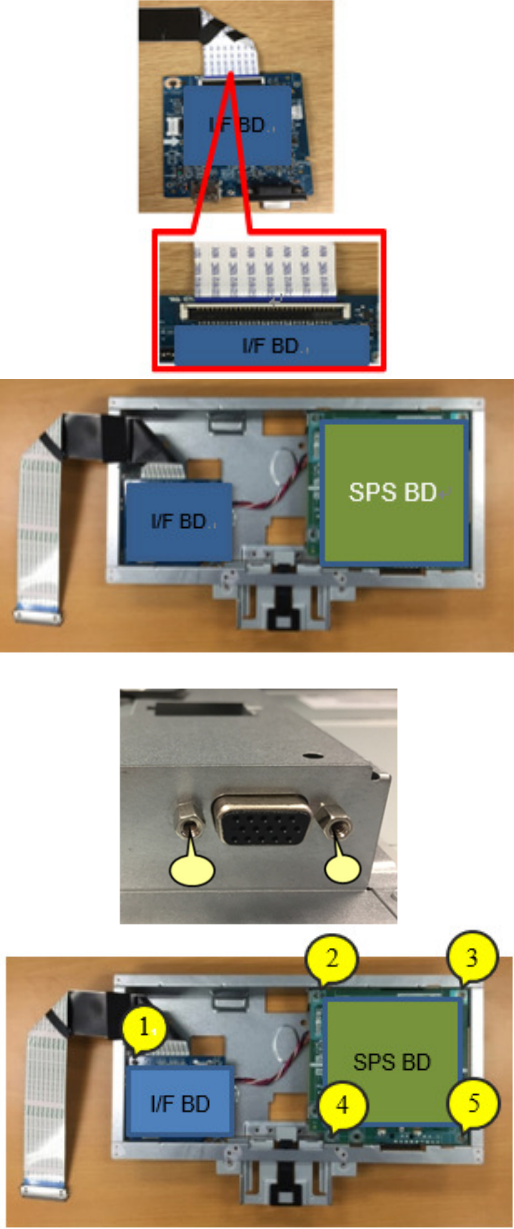
Item	Picture	Operation	Tools	Notes
1		<ol style="list-style-type: none"> <li>1. Assemble SPS BD in main SHD</li> <li>2. Insert LVDS cable into I/F BD.</li> <li>3. Insert the wire into I/F BD and assemble I/F BD into Main SHD</li> <li>4. Lock 5 PCB screws and 2 hex screws</li> </ol>	<ol style="list-style-type: none"> <li>1. Philips-head screwdriver  Torsion of PCB screw: 6.5±1.0Kg</li> <li>2. Hex-head screwdriver  Torsion of hex screw: 5.0±0.6Kg</li> </ol>	

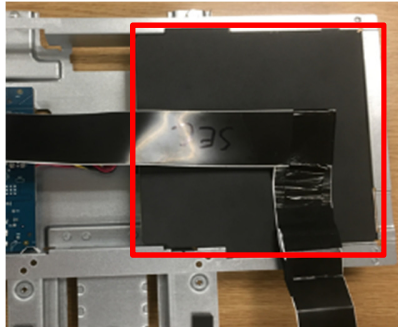
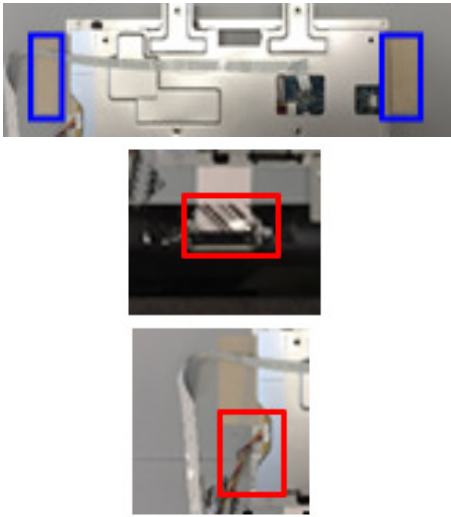
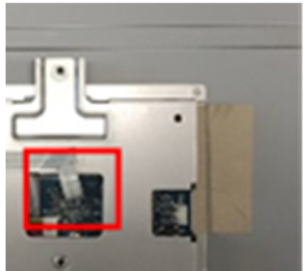
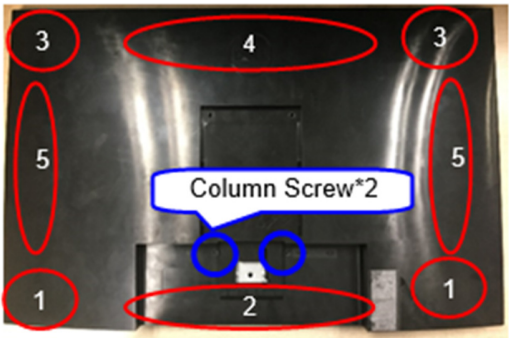
2		<ol style="list-style-type: none"> <li>1. Place panel on worktable with panel surface facing down</li> <li>2. Assemble Mylar on SHD</li> </ol>		
3		<ol style="list-style-type: none"> <li>1. Place Main SHD on panel and use 2 tapes to fix Main SHD's position</li> <li>2. Insert LVDS cable to panel and paste 1 tape to fix LVDS cable</li> <li>3. Insert backlight wire into panel and SPS BD</li> <li>4. Paste 1 tape to fix backlight wire</li> </ol>		
4		<ol style="list-style-type: none"> <li>1. Insert Control BD FFC cable to I/F BD and paste Control BD FFC cable on Main SHD and Panel</li> </ol>		
5		<ol style="list-style-type: none"> <li>1. Assemble Rear Cover with Bezel</li> <li>2. Follow the sequence to press on Rear Cover to make it be assembled with Bezel tightly</li> <li>3. Lock 2 Column screws</li> </ol>	<p>Philips-head screwdriver</p> <p>Torsion of CLMN screw: 4.5±0.5Kg</p>	

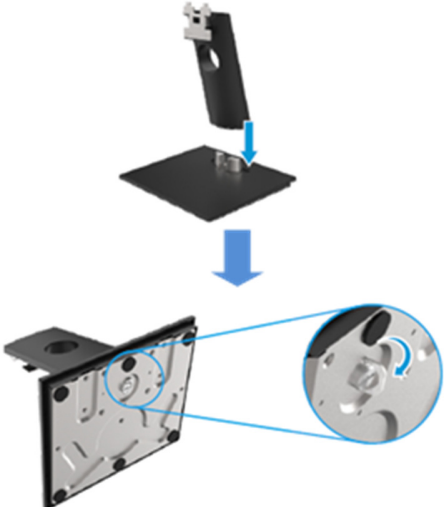
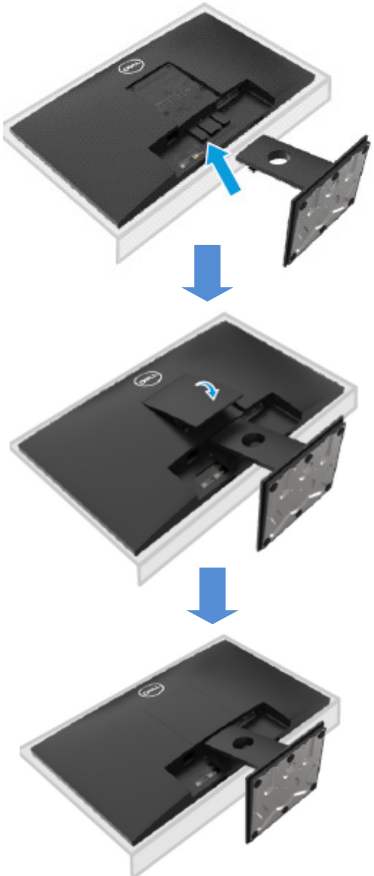
6		<ol style="list-style-type: none"> <li>1. Lock 4 screws on Rear Cover</li> </ol>	<p>Philips-head screwdriver</p> <p>Torsion of RC screw: 8~10Kg</p>	
7		<ol style="list-style-type: none"> <li>1. Assemble the stand column to stand base.</li> </ol>		
8		<ol style="list-style-type: none"> <li>1. Attach the stand assembly to the monitor.</li> <li>2. Attach the VESA Cover on Rear Cover</li> </ol>		



## 5. Trouble shooting instructions

# Troubleshooting

---

**⚠ WARNING:** Before you begin any of the procedures in this section, follow the [Safety Instructions](#).

### Self-test

Your monitor provides a self-test feature that allows you to check if your monitor is functioning properly. If your monitor and computer are properly connected but the monitor screen remains dark, run the monitor self-test by performing the following steps:

1. Turn off both your computer and the monitor.
2. Disconnect all video cables from the monitor. This way, the computer doesn't have to be involved.
3. Turn on the monitor.

If the monitor is working correctly, it detects that there is no signal and one of the following message appears. While in self-test mode, the power LED remains white.

E1920H

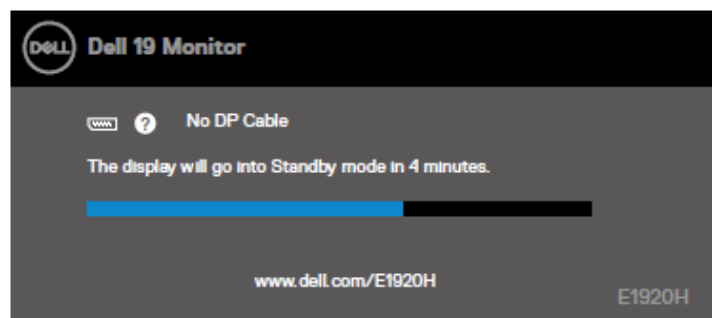

E2020H

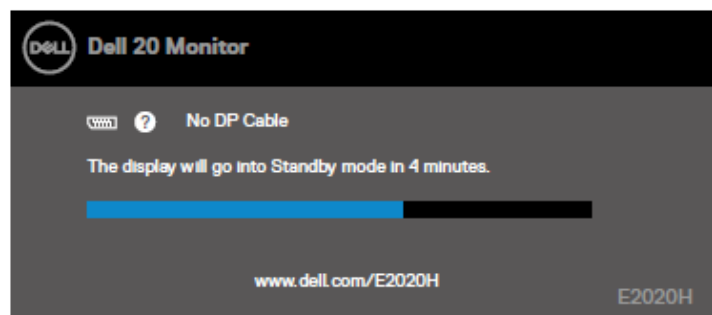

E2220H

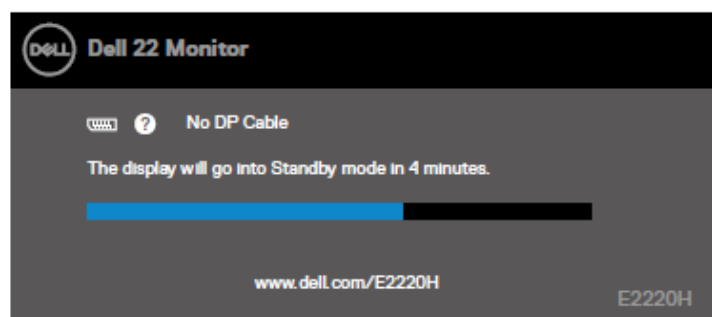

E2420H

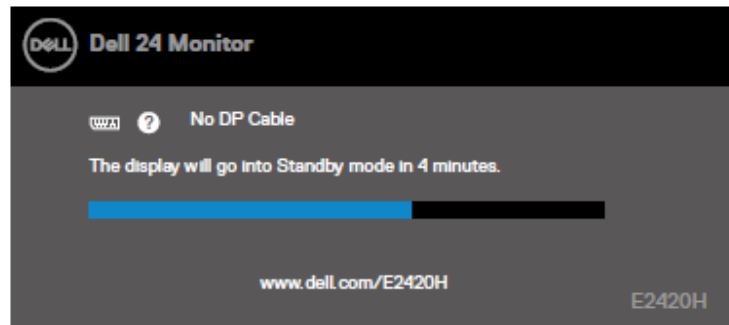

E2420HS

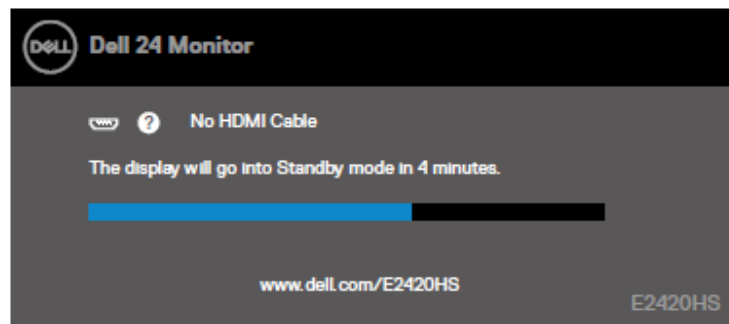

E2720H

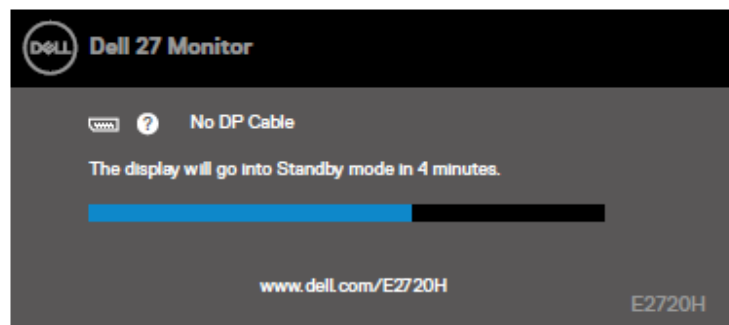

E2720HS

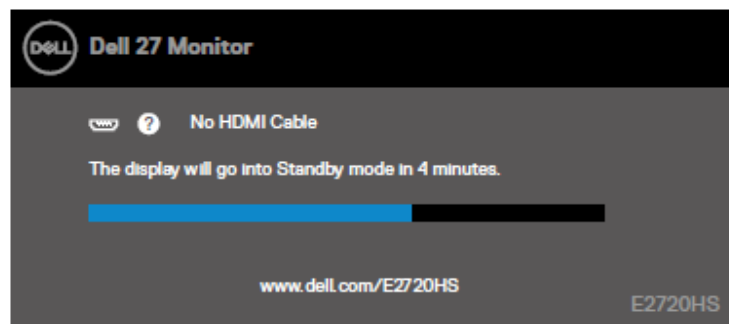

**NOTE:** This box also appears during normal operation, when the video cable is disconnected or damaged.

4. Turn off your monitor and reconnect the video cable; then turn on your computer and the monitor.

If your monitor remains dark after you reconnect the cables, check your video controller and computer.



## Built-in diagnostics

Your monitor has a built-in diagnostic tool that helps you determine if any screen abnormality you experience is an inherent problem with your monitor, or with your computer and video card.

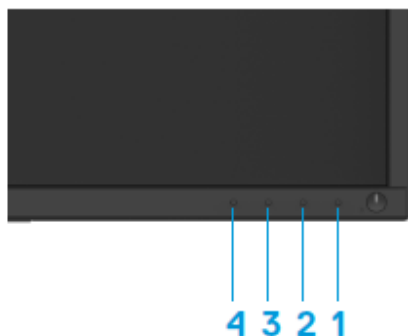

Label	Description
1	Button 1
2	Button 2
3	Button 3
4	Button 4

### To run the built-in diagnostics:

1. Ensure that the screen is clean (no dust particles on the surface of the screen).
2. Press and Hold button 1 for about 4 seconds and wait for a pop up menu.
3. Press button 3 or 4 to select the diagnostic tool and confirm with button 2.  
A gray test pattern appears at the beginning of the diagnostic program.
4. Carefully inspect the screen for abnormalities.
5. Press button 4 to change the test patterns.
6. Repeat steps 4 and 5 to inspect red, green, blue, black, white and text screens.
7. Press button 4 to end the diagnostic program.

## Common problems

The following table contains general information about common monitor problems you might encounter and the possible solutions:

Common Symptoms	Possible Solutions
No Video/Power LED off	<ul style="list-style-type: none"><li>• Ensure that the video cable connecting the monitor and the computer is properly connected and secure.</li><li>• Verify that the power outlet is functioning properly using any other electrical equipment.</li><li>• Ensure that the power button is pressed.</li><li>• Ensure that the correct input source is selected via the <b>Input Source</b> menu.</li></ul>
No Video/Power LED on	<ul style="list-style-type: none"><li>• Increase brightness and contrast controls using the OSD.</li><li>• Perform monitor self-test feature check.</li><li>• Check for bent or broken pins in the video cable connector.</li><li>• Run the built-in diagnostics.</li><li>• Ensure that the correct input source is selected via the <b>Input Source</b> menu.</li></ul>
Poor focus	<ul style="list-style-type: none"><li>• Eliminate video extension cables.</li><li>• Reset the monitor to Factory Settings (<b>Factory Reset</b>).</li><li>• Change the video resolution to the correct aspect ratio.</li></ul>
Shaky/Jittery video	<ul style="list-style-type: none"><li>• Reset the monitor to Factory Settings (<b>Factory Reset</b>).</li><li>• Check environmental factors.</li><li>• Relocate the monitor and test in another room.</li></ul>
Missing pixels	<ul style="list-style-type: none"><li>• Cycle power On-off.</li><li>• Pixel that is permanently off is a natural defect that can occur in LCD technology.</li><li>• For more information on Dell Monitor Quality and Pixel Policy, see Dell Support site at: <a href="http://www.dell.com/support/monitors">www.dell.com/support/monitors</a>.</li></ul>
Stuck-on pixels	<ul style="list-style-type: none"><li>• Cycle power On-off.</li><li>• Pixel that is permanently off is a natural defect that can occur in LCD technology.</li><li>• For more information on Dell Monitor Quality and Pixel Policy, see Dell Support site at: <a href="http://www.dell.com/support/monitors">www.dell.com/support/monitors</a>.</li></ul>
Brightness problems	<ul style="list-style-type: none"><li>• Reset the monitor to Factory Settings (<b>Factory Reset</b>).</li><li>• Adjust brightness &amp; contrast controls via OSD.</li></ul>
Geometric distortion	<ul style="list-style-type: none"><li>• Reset the monitor to Factory Settings (<b>Factory Reset</b>).</li><li>• Adjust brightness &amp; contrast controls via OSD.</li></ul>
Horizontal/Vertical lines	<ul style="list-style-type: none"><li>• Reset the monitor to Factory Settings (<b>Factory Reset</b>).</li><li>• Perform monitor self-test feature check and determine if these lines are also in self-test mode.</li><li>• Check for bent or broken pins in the video cable connector.</li><li>• Run the built-in diagnostics.</li></ul>

Synchronization problems	<ul style="list-style-type: none"> <li>• Reset the monitor to Factory Settings (<b>Factory Reset</b>).</li> <li>• Perform monitor self-test feature check to determine if the scrambled screen appears in self-test mode.</li> <li>• Check for bent or broken pins in the video cable connector.</li> <li>• Restart the computer in safe mode.</li> </ul>
Safety related issues	<ul style="list-style-type: none"> <li>• Do not perform any troubleshooting step.</li> <li>• Contact Dell immediately.</li> </ul>
Intermittent problems	<ul style="list-style-type: none"> <li>• Try different <b>Preset Modes</b> in <b>Color</b> settings OSD. Adjust <b>R/G/B</b> value in <b>Custom Color</b> in <b>Color</b> settings OSD.</li> <li>• Change the <b>Input Color Format</b> to <b>RGB</b> or <b>YPbPr</b> in the <b>Color</b> settings OSD.</li> <li>• Run the built-in diagnostics.</li> </ul>
Image retention from a static image left on the monitor for a long period of time	<ul style="list-style-type: none"> <li>• Use the Power Management feature to turn off the monitor all times when not in use (for more information, see <a href="#">Power management modes</a>).</li> <li>• Alternatively, use a dynamically changing screensaver.</li> </ul>
Video ghosting or overshooting	<ul style="list-style-type: none"> <li>• Change the <b>Response Time</b> in the <b>Display</b> OSD to <b>Fast</b> or <b>Normal</b> depending on your application and usage.</li> </ul>

## Product-specific problems

Specific Symptoms	Possible Solutions
Screen image is too small	<ul style="list-style-type: none"><li>• Check the <b>Aspect Ratio</b> setting in the <b>Display</b> settings OSD.</li><li>• Reset the monitor to Factory Settings (<b>Factory Reset</b>).</li></ul>
Cannot adjust the monitor with the buttons on the bottom of the panel	<ul style="list-style-type: none"><li>• Turn off the monitor, unplug the power cord, plug it back, and then turn on the monitor.</li></ul>
No input signal when user controls are pressed	<ul style="list-style-type: none"><li>• Check the signal source. Ensure the computer is not in standby or sleep mode by moving the mouse or pressing any key on the keyboard.</li><li>• Check if the video cable is plugged in properly. Disconnect and reconnect the video cable if necessary.</li><li>• Reset the computer or video player.</li></ul>
The picture does not fill the entire screen	<ul style="list-style-type: none"><li>• Due to different video formats (aspect ratio) of DVDs, the monitor may display in full screen.</li><li>• Run the built-in diagnostics.</li></ul>